

## Industrial Automation Headquarters

**Delta Electronics, Inc.**  
Taoyuan Technology Center  
No.18, Xinglong Rd., Taoyuan District,  
Taoyuan City 33068, Taiwan  
TEL: 886-3-362-6301 / FAX: 886-3-371-6301

## Asia

**Delta Electronics (Shanghai) Co., Ltd.**  
No.182 Minyu Rd., Pudong Shanghai, P.R.C.  
Post code : 201209  
TEL: 86-21-6872-3988 / FAX: 86-21-6872-3996  
Customer Service: 400-820-9595

**Delta Electronics (Japan), Inc.**  
Tokyo Office  
Industrial Automation Sales Department  
2-1-14 Shibadaimon, Minato-ku  
Tokyo, Japan 105-0012  
TEL: 81-3-5733-1155 / FAX: 81-3-5733-1255

**Delta Electronics (Korea), Inc.**  
Seoul Office  
1511, 219, Gasan Digital 1-Ro., Geumcheon-gu,  
Seoul, 08501 South Korea  
TEL: 82-2-515-5305 / FAX: 82-2-515-5302

**Delta Energy Systems (Singapore) Pte Ltd.**  
4 Kaki Bukit Avenue 1, #05-04, Singapore 417939  
TEL: 65-6747-5155 / FAX: 65-6744-9228

**Delta Electronics (India) Pvt. Ltd.**  
Plot No.43, Sector 35, HSIIDC Gurgaon,  
PIN 122001, Haryana, India  
TEL: 91-124-4874900 / FAX : 91-124-4874945

**Delta Electronics (Thailand) PCL.**  
909 Soi 9, Moo 4, Bangpoo Industrial Estate (E.P.Z),  
Pattana 1 Rd., T.Phraksa, A.Muang,  
Samutprakarn 10280, Thailand  
TEL: 66-2709-2800 / FAX : 662-709-2827

**Delta Energy Systems (Australia) Pty Ltd.**  
Unit 20-21/45 Normanby Rd., Notting Hill Vic 3168, Australia  
TEL: 61-3-9543-3720

## Americas

**Delta Electronics (Americas) Ltd.**  
Raleigh Office  
P.O. Box 12173, 5101 Davis Drive,  
Research Triangle Park, NC 27709, U.S.A.  
TEL: 1-919-767-3813 / FAX: 1-919-767-3969

**Delta Greentech (Brasil) S/A**  
São Paulo Office  
Rua Itapeva, 26 – 3° Andar - Bela Vista  
CEP: 01332-000 – São Paulo – SP - Brasil  
TEL: 55-11-3530-8642 / 55-11-3530-8640

**Delta Electronics International Mexico S.A. de C.V.**  
Mexico Office  
Via Dr. Gustavo Baz No. 2160, Colonia La Loma,  
54060 Tlalnepantla Estado de Mexico  
TEL: 52-55-2628-3015 #3050/3052

## EMEA

**Headquarters: Delta Electronics (Netherlands) B.V.**  
Sales: Sales.IA.EMEA@deltaww.com  
Marketing: Marketing.IA.EMEA@deltaww.com  
Technical Support: iatechnicalsupport@deltaww.com  
Customer Support: Customer-Support@deltaww.com  
Service: Service.IA.emea@deltaww.com  
TEL: +31(0)40 800 3800

**BENELUX: Delta Electronics (Netherlands) B.V.**  
De Witbogt 20, 5652 AG Eindhoven, The Netherlands  
Mail: Sales.IA.Benelux@deltaww.com  
TEL: +31(0)40 800 3800

**DACH: Delta Electronics (Netherlands) B.V.**  
Coesterweg 45, D-59494 Soest, Germany  
Mail: Sales.IA.DACH@deltaww.com  
TEL: +49(0)2921 987 0

**France: Delta Electronics (France) S.A.**  
ZI du bois Challand 2, 15 rue des Pyrénées,  
Lisses, 91090 Evry Cedex, France  
Mail: Sales.IA.FR@deltaww.com  
TEL: +33(0)1 69 77 82 60

**Iberia: Delta Electronics Solutions (Spain) S.L.U**  
Ctra. De Villaverde a Vallecas, 265 1º Dcha Ed.  
Hormigueras – P.I. de Vallecas 28031 Madrid  
TEL: +34(0)91 223 74 20  
C/Liull, 321-329 (Edifici CINC) | 22@Barcelona, 08019 Barcelona  
Mail: Sales.IA.Iberia@deltaww.com  
TEL: +34 93 303 00 60

**Italy: Delta Electronics (Italy) S.r.l.**  
Ufficio di Milano Via Senigallia 18/2 20161 Milano (MI)  
Piazza Grazioli 18 00186 Roma Italy  
Mail: Sales.IA.Italy@deltaww.com  
TEL: +39 02 64672538

**Russia: Delta Energy System LLC**  
Vereyskaya Plaza II, office 112 Vereyskaya str.  
17 121357 Moscow Russia  
Mail: Sales.IA.RU@deltaww.com  
TEL: +7 495 644 3240

**Turkey: Delta Greentech Elektronik San. Ltd. Sti. (Turkey)**  
Şerifali Mah. Hendem Cad. Kule Sok. No:16-A  
34775 Ümraniye – İstanbul  
Mail: Sales.IA.Turkey@deltaww.com  
TEL: + 90 216 499 9910

**GCC: Delta Energy Systems AG (Dubai BR)**  
P.O. Box 185668, Gate 7, 3rd Floor, Hamarain Centre  
Dubai, United Arab Emirates  
Mail: Sales.IA.MEA@deltaww.com  
TEL: +971(0)4 2690148

**Egypt + North Africa: Delta Electronics**  
511 Cairo Business Plaza, North 90 street,  
New Cairo, Cairo, Egypt  
Mail: Sales.IA.MEA@deltaww.com

## Delta Vector Control Drive - C2000 Series User Manual



# Delta Vector Control Drive C2000 Series User Manual



## **Copyright notice**

©Delta Electronics, Inc. All rights reserved.

All information contained in this user manual is the exclusive property of Delta Electronics Inc.

(hereinafter referred to as "Delta ") and is protected by copyright law and all other laws. Delta retains the exclusive rights of this user manual in accordance with the copyright law and all other laws. No parts in this manual may be reproduced, transmitted, transcribed, translated or used in any other ways without the prior consent of Delta.

## **Limitation of Liability**

The contents of this user manual are only for the use of the AC motor drives manufactured by Delta. Except as defined in special mandatory laws, Delta provides this user manual "as is" and does not offer any kind of warranty through this user manual for using the product, either express or implied, including but not limited to the following: (i) this product will meet your needs or expectations; (ii) the information contained in the product is current and correct; (iii) the product does not infringe any rights of any other person. You shall bear your own risk to use this product.

In no event shall Delta, its subsidiaries, affiliates, managers, employees, agents, partners and licensors be liable for any direct, indirect, incidental, special, derivative or consequential damages ( including but not limited to the damages for loss of profits, goodwill, use or other intangible losses) unless the laws contains special mandatory provisions to the contrary.

Delta reserves the right to make changes to the user manual and the products described in the user manual without prior notice and afterwards.





**PLEASE READ PRIOR TO INSTALLATION FOR SAFETY.**



- Disconnect AC input power before connecting any wiring to the AC motor drive.
- Even if the power has been turned off, a charge may still remain in the DC-link capacitors with hazardous voltages before the POWER LED is OFF. Do NOT touch the internal circuits and components.
- There are highly sensitive MOS components on the printed circuit boards. These components are especially sensitive to static electricity. Take anti-static measure before touching these components or the circuit boards.
- Never modify the internal components or wiring.
- Ground the AC motor drive by using the ground terminal. The grounding method must comply with the laws of the country where the AC motor drive is to be installed.
- Do NOT install the AC motor drive in a location with high temperature, direct sunlight or inflammable materials or gases.



- Never connect the AC motor drive output terminals U/T1, V/T2 and W/T3 directly to the AC mains circuit power supply.
- After finishing the wiring of the AC motor drive, check if U/T1, V/T2, and W/T3 are short-circuited to ground with a multimeter. Do NOT power the drive if short circuits occur. Eliminate the short circuits before the drive is powered.
- The rated voltage of power system to install motor drives is listed below. Ensure that the installation voltage is in the correct range when installing a motor drive.
  1. For 230V models, the range is between 170–264V.
  2. For 460V models, the range is between 323–528V.
  3. For 575V models, the range is between 446–660V.
  4. For 690V models, the range is between 446–759V.

Refer to the table below for short circuit rating:

Model (Power)	Short circuit rating
230V / 460V	100 kA
575V (2–20HP)	5 kA
690V (25–50HP)	5 kA
690V (60–175HP)	10 kA
690V (215–335HP)	18 kA
690V (425–600HP)	30 kA
690V (745–850HP)	42 kA

- Only qualified persons are allowed to install, wire and maintain the AC motor drives.
- Even if the three-phase AC motor is stopped, a charge with hazardous voltages may still remain in the main circuit terminals of the AC motor drive.
- The performance of electrolytic capacitor will degrade if it is not charged for a long time. It is recommended to charge the drive which is stored in no charge condition every 2 years for 3~4 hours to restore the performance of electrolytic capacitor in the motor drive. Note: When power up the motor drive, use adjustable AC power source (ex. AC autotransformer) to charge the drive at 70%~80% of rated voltage for 30 minutes (do not run the motor drive). Then charge the drive at 100% of rated voltage for an hour (do not run the motor drive). By doing these, restore the performance of electrolytic capacitor before starting to run the motor drive. Do NOT run the motor drive at 100% rated voltage right away.
- Pay attention to the following precautions when transporting and installing this package (including wooden crate and wood stave)
  1. If you need to deworm the wooden crate, do NOT use fumigation or you will damage the drive. Any damage to the drive caused by using fumigation voids the warranty.



2. Use other methods, such as heat treatment or any other non-fumigation treatment, to deworm the wood packaging material.
  3. If you use heat treatment to deworm, leave the packaging materials in an environment of over 56°C for a minimum of thirty minutes.
- ☑ Connect the drive to a three-phase three-wire or three-phase four-wire Wye system to comply with UL standards.
  - ☑ If the motor drive generates leakage current over AC 3.5 mA or over DC 10 mA on a grounding conductor, compliance with local grounding regulations or IEC61800-5-1 standard is the minimum requirement for grounding.

 **NOTE**

The content of this manual may be revised without prior notice. Please consult our distributors or download the latest version at [http://www.deltaww.com/iadownload\\_acmotordrive](http://www.deltaww.com/iadownload_acmotordrive)

# Table of Contents

<b>CHAPTER 1 INTRODUCTION</b> .....	<b>1-1</b>
1-1 Nameplate Information.....	1-2
1-2 Model Name.....	1-3
1-3 Serial Number.....	1-4
1-4 Apply After Service by Mobile Device.....	1-5
1-5 RFI Jumper.....	1-6
1-6 Dimensions.....	1-9
<b>CHAPTER 2 INSTALLATION</b> .....	<b>2-1</b>
2-1 Mounting Clearance.....	2-2
2-2 Air Flow and Power Dissipation.....	2-5
<b>CHAPTER 3 UNPACKING</b> .....	<b>3-1</b>
3-1 Unpacking.....	3-2
3-2 The Lifting Hook.....	3-25
<b>CHAPTER 4 WIRING</b> .....	<b>4-1</b>
4-1 System Wiring Diagram.....	4-3
4-2 Wiring.....	4-4
<b>CHAPTER 5 MAIN CIRCUIT TERMINALS</b> .....	<b>5-1</b>
5-1 Main Circuit Diagram.....	5-4
5-2 Specifications of Main Circuit Terminals.....	5-7
<b>CHPATER 6 CONTROL TERMINALS</b> .....	<b>6-1</b>
6-1 Remove the Cover for Wiring.....	6-4
6-2 Specifications of Control Terminal.....	6-7
6-3 Remove the Terminal Block.....	6-10
<b>CHAPTER 7 OPTIONAL ACCESSORIES</b> .....	<b>7-1</b>
7-1 All Brake Resistors and Brake Units Used in AC Motor Drives.....	7-2
7-2 Non-fuse Circuit Breaker.....	7-7
7-3 Fuse Specification Chart .....	7-8
7-4 AC / DC Reactor.....	7-10
7-5 Zero Phase Reactor.....	7-44
7-6 EMC Filter.....	7-50



7-7 Digital Keypad.....	7-70
7-8 Panel Mounting.....	7-72
7-9 Conduit Box Kit.....	7-89
7-10 Fan Kit.....	7-105
7-11 Flange Mounting Kit .....	7-120
7-12 USB/RS-485 Communication Interface IFD6530.....	7-122
<b>CHAPTER 8 OPTION CARDS.....</b>	<b>8-1</b>
8-1 Option Card Installation.....	8-2
8-2 EMC-D42A -- Extension card for 4-point digital input / 2-point digital input.....	8-14
8-3 EMC-D611A -- Extension card for 6-point digital input (110V <sub>AC</sub> input voltage).....	8-14
8-4 EMC-R6AA -- Relay output extension card (6-point N.O. output contact).....	8-14
8-5 EMC-A22A -- Extension card for 2-point analog input/ 2-point analog output.....	8-15
8-6 EMC-BPS01 -- +24V power card.....	8-15
8-7 EMC-PG01/02L -- PG card (Line driver).....	8-16
8-8 EMC-PG01/02O -- PG card (Open collector).....	8-19
8-9 EMC-PG01/02U -- PG card (ABZ Incremental encoder signal/ UVW Hall position signal input).....	8-22
8-10 EMC-PG01R -- PG card (Resolver).....	8-24
8-11 CMC-MOD01 -- Communication card, Modbus TCP.....	8-26
8-12 CMC-PD01 -- Communication card, PROFIBUS DP.....	8-29
8-13 CMC-DN01 -- Communication card, DeviceNet.....	8-31
8-14 CMC-EIP01 -- Communication card, EtherNet/IP.....	8-34
8-15 CMC-EC01 -- Communication card, EtherCAT.....	8-38
8-16 CMC-PN01 -- Communication card, PROFINET.....	8-41
8-17 EMC-COP01 -- Communication card, CANopen.....	8-45
8-18 Delta Standard Fieldbus Cables.....	8-46
<b>CHAPTER 9 SPECIFICATION.....</b>	<b>9-1</b>
9-1 230V Series.....	9-2
9-2 460V Series.....	9-3
9-3 575V Series.....	9-5
9-4 690V Series.....	9-6
9-5 Environment for Operation, Storage and Transportation.....	9-10
9-6 Specification for Operation Temperature and Protection Level.....	9-11
9-7 Derating Curve of Ambient Temperature.....	9-12
9-8 Efficiency Curve.....	9-17
<b>CHAPTER 10 DIGITAL KEYPAD .....</b>	<b>10-1</b>
10-1 Descriptions of Digital Keypad .....	10-2
10-2 Function of Digital Keypad KPC-CC01.....	10-5
10-3 TPEditor Installation Instruction .....	10-26

10-4 Fault Code Description of Digital Keypad KPC-CC01.....	10-34
10-5 Unsupported Functions when using TPEditor on KPC-CC01 Keypad.....	10-38

**CHAPTER 11 SUMMARY OF PARAMETERS ..... 11-1**

00 Drive Parameters.....	11-1
01 Basic Parameters.....	11-10
02 Digital Input / Output Parameters.....	11-14
03 Analog Input / Output Parameters.....	11-20
04 Multi-stage Speed Parameters.....	11-24
05 Motor Parameters.....	11-27
06 Protection Parameters.....	11-30
07 Special Parameters.....	11-37
08 High-function PID Parameters.....	11-40
09 Communication Parameters.....	11-42
10 Feedback Control Parameters.....	11-47
11 Advanced Parameters.....	11-50
13 Application Parameters by Industry.....	11-53
14 Extension Card Parameter.....	11-54

**CHAPTER 12 DESCRIPTION OF PARAMETER SETTINGS ..... 12-1**

12-1 Description of Parameter Settings .....	12.1-00-1
00 Drive Parameters.....	12.1-00-1
01 Basic Parameters.....	12.1-01-1
02 Digital Input / Output Parameters.....	12.1-02-1
03 Analog Input / Output Parameters.....	12.1-03-1
04 Multi-stage Speed Parameters.....	12.1-04-1
05 Motor Parameters.....	12.1-05-1
06 Protection Parameters.....	12.1-06-1
07 Special Parameters.....	12.1-07-1
08 High-function PID Parameters.....	12.1-08-1
09 Communication Parameters.....	12.1-09-1
10 Feedback Control Parameters.....	12.1-10-1
11 Advanced Parameters.....	12.1-11-1
13 Application Parameters by Industry.....	12.1-13-1
14 Extension Card Parameter.....	12.1-14-1
12-2 Adjustment & Application.....	12.2-00-1

**CHAPTER 13 WARNING CODES ..... 13-1**

**CHAPTER 14 FAULT CODES AND DESCRIPTIONS..... 14-1**



<b>CHAPTER 15 CANOPEN OVERVIEW</b> .....	<b>15-1</b>
15-1 CANopen Overview.....	15-3
15-2 Wiring for CANopen.....	15-6
15-3 CANopen Communication Interface Description.....	15-7
15-4 CANopen Supporting Index .....	15-19
15-5 CANopen Fault Codes .....	15-26
15-6 CANopen LED Function.....	15-34
<b>CHAPTER 16 PLC FUNCTION APPLICATIONS</b> .....	<b>16-1</b>
16-1 PLC Summary.....	16-2
16-2 Notes Before PLC Use.....	16-3
16-3 Turn On.....	16-5
16-4 Basic Principles of PLC Ladder Diagrams.....	16-15
16-5 Various PLC Device Functions.....	16-26
16-6 Introduction To The Command Window.....	16-41
16-7 Error Display And Handling.....	16-131
16-8 CANopen Master Control Applications.....	16-132
16-9 Explanation Of Various PLC Mode Controls (speed, torque, homing, and position).....	16-145
16-10 Internal Communications Main Node Control.....	16-151
16-11 Count Function Using MI8.....	16-155
16-12 Modbus Remote IO Control Applications (use MODRW).....	16-156
16-13 Calendar Function.....	16-163
<b>CHAPTER 17 SAFE TORQUE OFF FUNCTION</b> .....	<b>17-1</b>
17-1 The Drive Safety Function Failure Rate.....	17-2
17-2 Safe Torque Off Terminal Function Description.....	17-2
17-3 Wiring Diagram.....	17-3
17-4 Parameters.....	17-5
17-5 Operating Sequence Description.....	17-6
17-6 New Error Code for STO Function.....	17-8
<b>APPENDIX A. REVISION HISTORY</b> .....	<b>A-1</b>

**Issued Edition: 01**  
**Firmware Version: V2.05**  
(Refer to Parameter 00-06 on the product to get the firmware version.)  
**Issued Date: 2019/02**

# ***Chapter 1 Introduction***

---

1-1 Nameplate Information

1-2 Model Name

1-3 Serial Number

1-4 Apply After Service by Mobile Device

1-5 RFI Jumper

1-6 Dimensions



## Receiving and Inspection

After receiving the AC motor drive, please check for the following:

1. Please inspect the unit after unpacking to assure it was not damaged during shipment. Make sure that the part number printed on the package corresponds with the part number indicated on the nameplate.
2. Make sure that the voltage for the wiring lies within the range as indicated on the nameplate. Please install the AC motor drive according to this manual.
3. Before applying the power, please make sure that all the devices, including power, motor, control board and digital keypad, are connected correctly.
4. When wiring the AC motor drive, please make sure that the wiring of input terminals “R/L1, S/L2, T/L3” and output terminals “U/T1, V/T2, W/T3” is correct to prevent drive damage.
5. When power is applied, select the language and set parameter groups via the digital keypad (KPC-CC01). When executes trial run, please begin with a low speed and then gradually increases the speed until the desired speed is reached.

### 1-1 Nameplate Information

#### 230V/460V Model

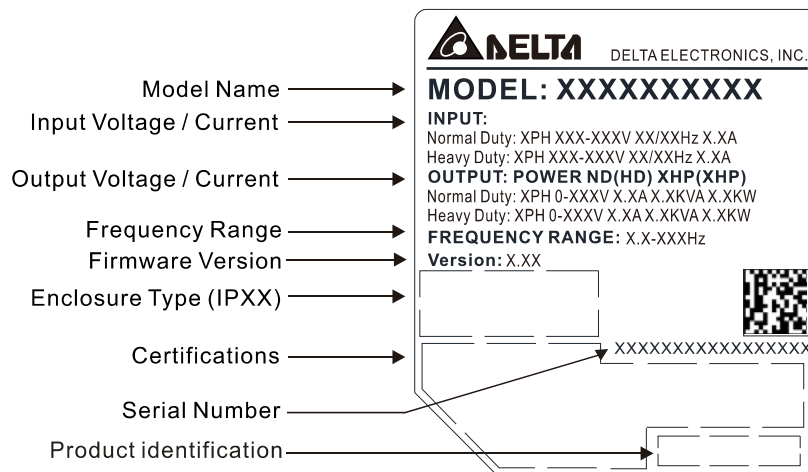

Figure 1-1

#### 575V/690V Model

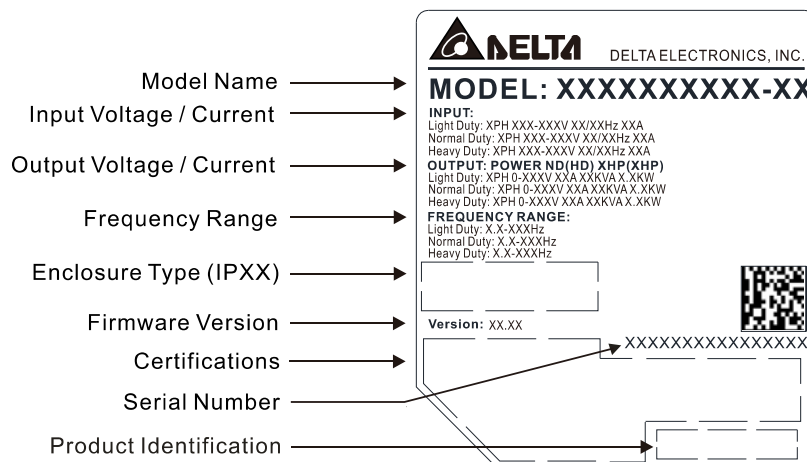
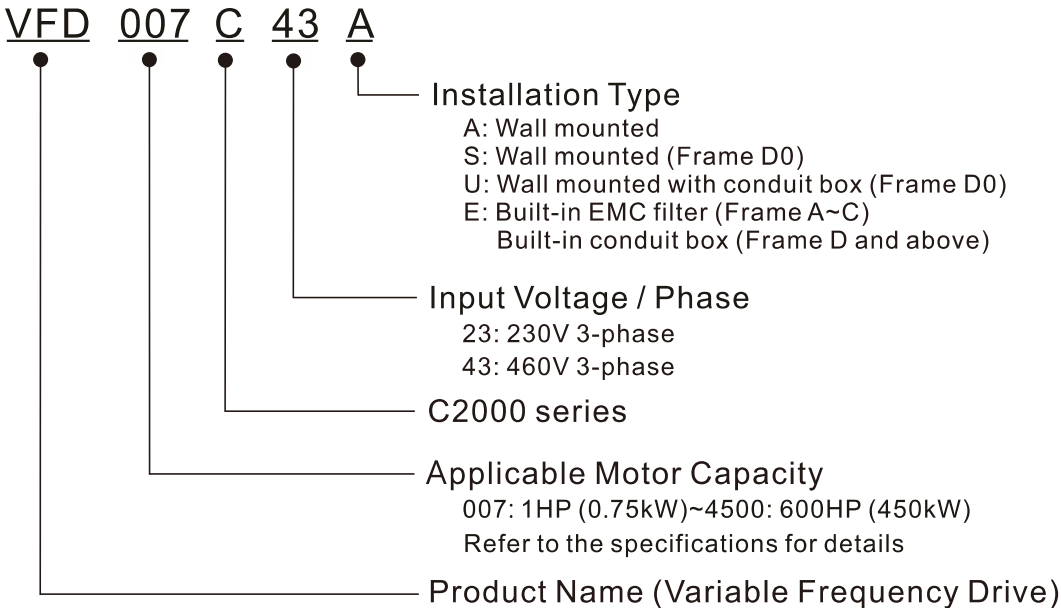

Figure 1-2

### 1-2 Model Name

#### 230V/460V Model



#### 575V/690V Model

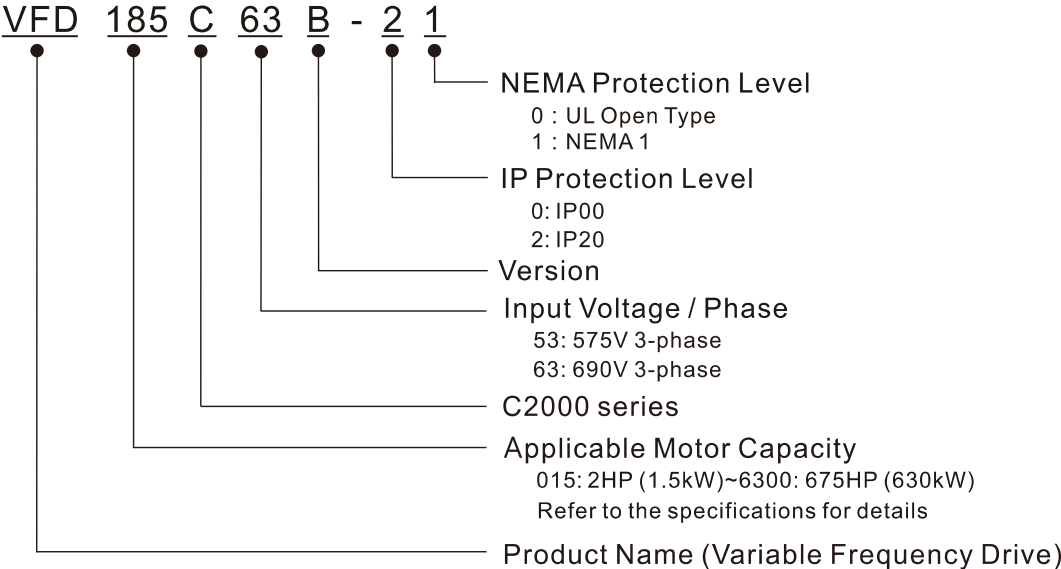

### 1-3 Serial Number 230V/460V Model

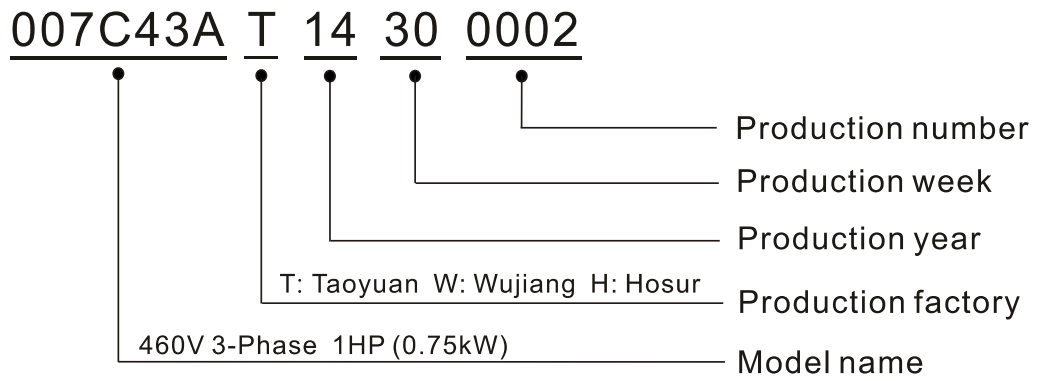

### 575V/690V Model

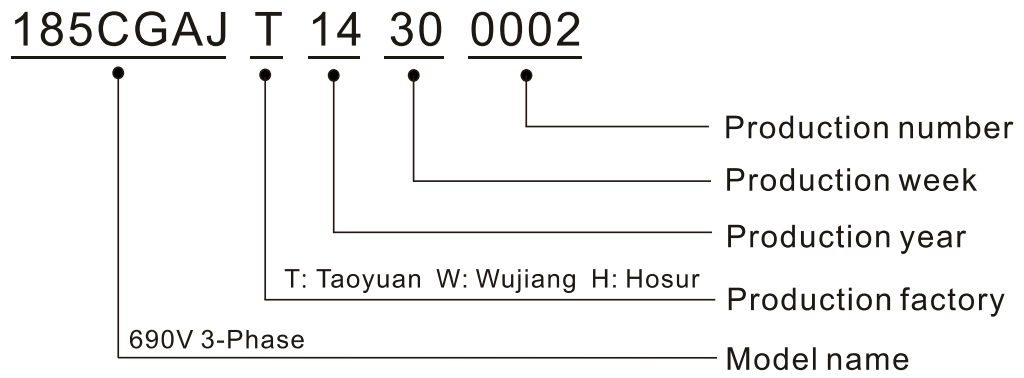

## 1-4 Apply After Service by Mobile Device

### 1-4-1 Location of Service Link Label

#### Frame A–H

Service link label (Service Label) will be pasted on the upper-right corner of the side where keypad is installed on the case body, as below drawing shown:

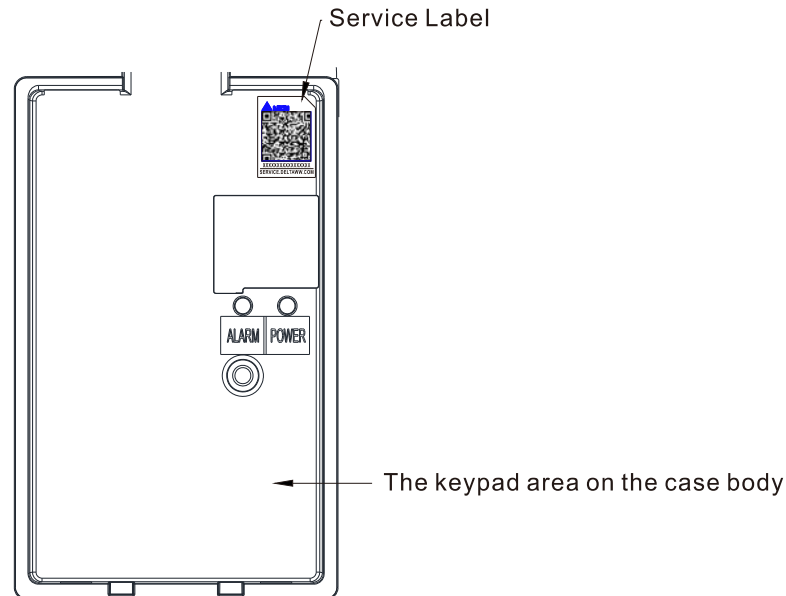

Figure 1-3

### 1-4-2 Service Link Label

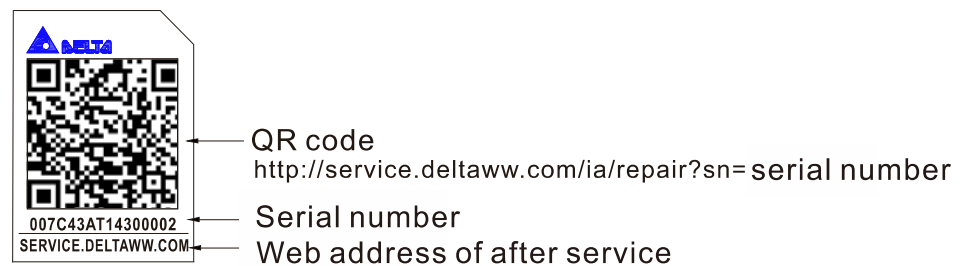

Figure 1-4

#### Scan QR Code to apply

1. Find out the QR code sticker (as above shown).
2. Using a Smartphone to run a QR Code reader APP.
3. Point your camera to the QR Code. Hold your camera steady so that the QR code comes into focus.
4. Access the Delta after Service website.
5. Fill your information into the column marked with an orange star.
6. Enter the CAPTCHA and click “Submit” to complete the application.

#### Cannot find out the QR Code?

1. Open a web browser on your computer or smart phone.
2. Key in <https://service.deltaww.com/ia/repair> in address bar and press enter
3. Fill your information into the columns marked with an orange star.
4. Enter the CAPTCHA and click “Submit” to complete the application.



## 1-5 RFI Jumper

(1) In the drive there are Varistor / MOVs, which are connected from phase to phase and from phase to ground, to protect the drive against mains surges or voltage spikes.

Because the Varistors / MOVs from phase to ground are connected to ground via the RFI jumper, the protection will be ineffective when the RFI jumper is removed.

(2) In the models with built-in EMC filter the RFI jumper connects the filter capacitors to ground from a return path for high frequency noise to isolate the noise from contaminating the mains power.

Removing the RFI jumper strongly reduces the effect of the built-in EMC filter. Although a single drive complies with the international standards for leakage current, an installation with several drives with built-in EMC filter can trigger the RCD. Removing the RFI jumper helps, but the EMC performance of each drive would be no longer guaranteed.

**Frame A–C** Screw Torque: 8–10 kg-cm / [6.9–8.7 lb-in.] / [0.8–1.0 Nm]

Loosen the screws and remove the MOV-PLATE. Fasten the screws back to the original position after MOV-PLATE is removed.

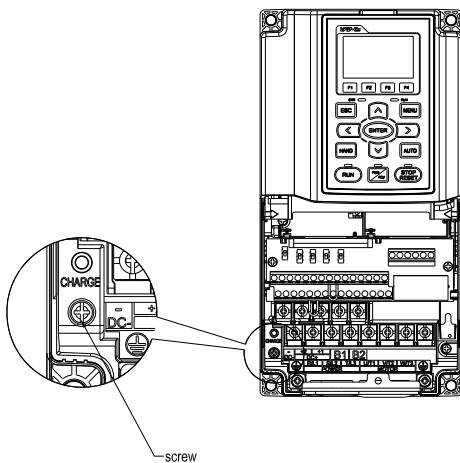

Figure 1-5

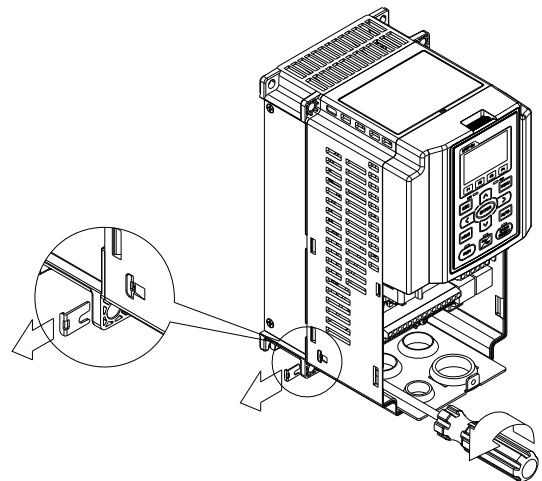

Figure 1-6

**Frame D0–H**

Remove the MOV-PLATE by hands, no screws need to be loosen.

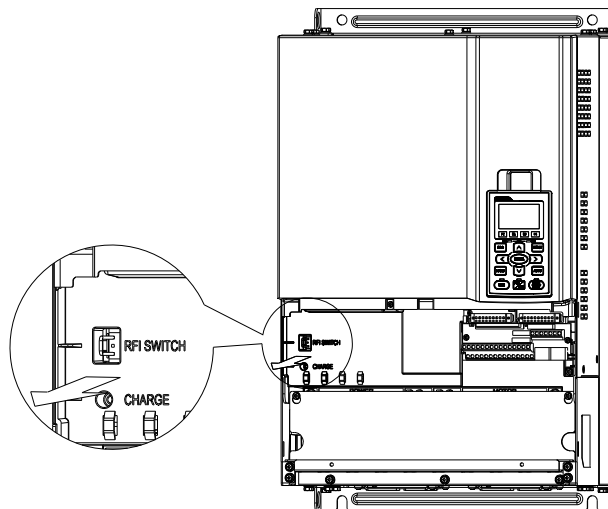

Figure 1-7

**Isolating main power from ground:**

When the power distribution system of the drive is a floating ground system (IT Systems) or an asymmetric ground system (Corner Grounded TN Systems), you must remove the RFI jumper. Removing the RFI jumper disconnects the internal capacitors from ground to avoid damaging the internal circuits and to reduce the ground leakage current.

**Important points regarding ground connection**

- ☑ To ensure the safety of personnel, proper operation, and to reduce electromagnetic radiation, you must properly ground the drive during installation.
- ☑ The diameter of the cables must comply with the local safety regulations.
- ☑ The shield of shielded cables must be connected to the ground of the drive to meet safety regulations.
- ☑ The shield of shielded power cables can only be used as the ground for equipment when the aforementioned points are met.
- ☑ When installing more drives, do not connect the grounds of the drives in series but connect each drive to ground. The following pictures show the correct and wrong ways to connect the grounds.

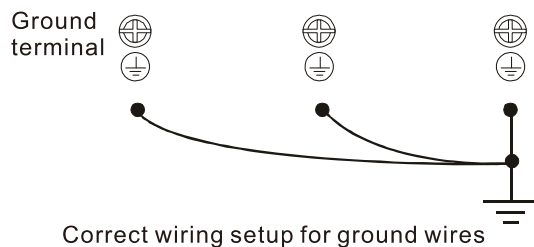

Figure 1-8

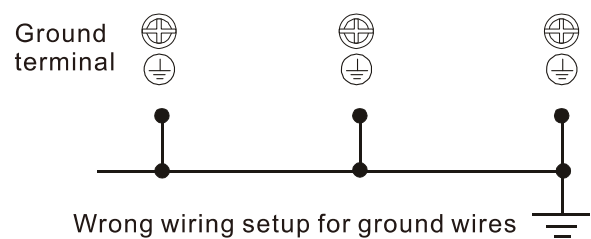

Figure 1-9

Pay particular attention to the following points:

- ☑ Do not remove the RFI jumper while the power is on.
- ☑ Removing the RFI jumper also disconnects the built-in EMC filter capacitors. Compliance with the EMC specifications is no longer guaranteed.
- ☑ Do not remove the RFI jumper if the mains power is a symmetrical grounded power system in order to maintain the efficiency for EMC circuit.
- ☑ Do not remove the RFI jumper while conducting high voltage tests. When conducting a high voltage test to the entire facility, you must disconnect the mains power and the motor if the leakage current is too high.

**Floating Ground System (IT Systems)**

A floating ground system is also called IT system, ungrounded system, or high impedance/resistance (greater than  $30\Omega$ ) grounding system.

- ☑ Disconnect the ground cable from the internal EMC filter.
- ☑ In situations where EMC is required, check whether there is excess electromagnetic radiation affecting nearby low-voltage circuits. In some situations, the adapter and cable naturally provide enough suppression. If in doubt, install an extra electrostatic shielded cable on the power supply side between the main circuit and the control terminals to increase security.
- ☑ Do not install an external RFI/EMC filter, the EMC filter will pass through a filter capacitor, thus connecting power input to ground. This is very dangerous and can easily damage the Power Regenerative Unit.

**Asymmetric Ground System (Corner Grounded TN Systems)**

Caution: Do not remove the RFI jumper while the input terminal of the Power Regenerative Unit carries power.

In the following four situations, the RFI jumper must be removed. This is to prevent the system from grounding through the RFI capacitor and damaging the Power Regenerative Unit.

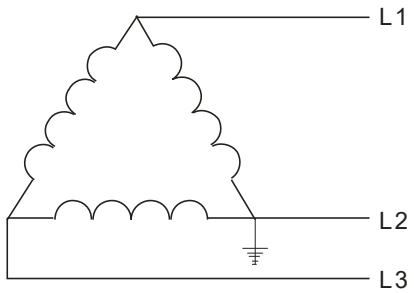
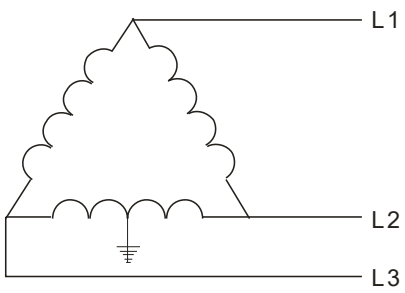
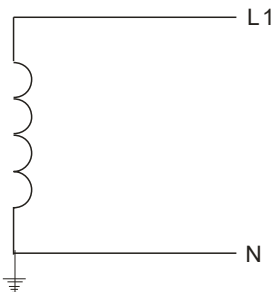
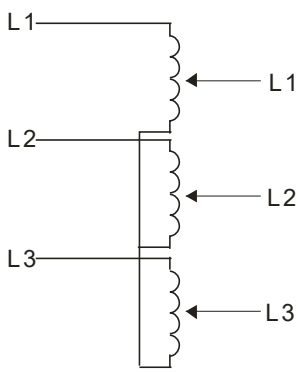
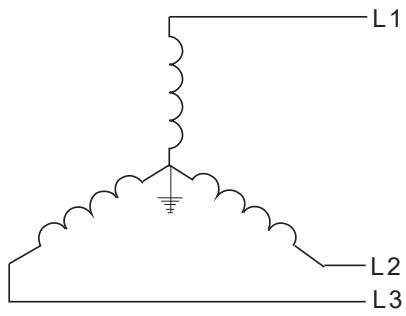
RFI jumper must be removed	
<p>1. Grounding at a corner in a triangle configuration</p>  <p style="text-align: center;">Figure 1-10</p>	<p>2. Grounding at a midpoint in a polygonal configuration</p>  <p style="text-align: center;">Figure 1-11</p>
<p>3. Grounding at one end in a single-phase configuration</p>  <p style="text-align: center;">Figure 1-12</p>	<p>4. No stable neutral grounding in a three-phase autotransformer configuration</p>  <p style="text-align: center;">Figure 1-13</p>
RFI jumper can be used	
<p>Internal grounding through RFI capacitor, which reduces electromagnetic radiation. In a situation with higher requirements for electromagnetic compatibility, and using a symmetrical grounding power system, an EMC filter can be installed. As a reference, the diagram on the right is a symmetrical grounding power system.</p>	 <p style="text-align: center;">Figure 1-14</p>

# 1-6 Dimensions

## Frame A

VFD007C23A; VFD007C43A/E; VFD015C23A; VFD015C43A/E; VFD022C23A; VFD022C43A/E;  
 VFD037C23A; VFD037C43A/E; VFD040C43A/E; VFD055C43A/E; VFD015C53A-21; VFD022C53A-21;  
 VFD037C53A-21

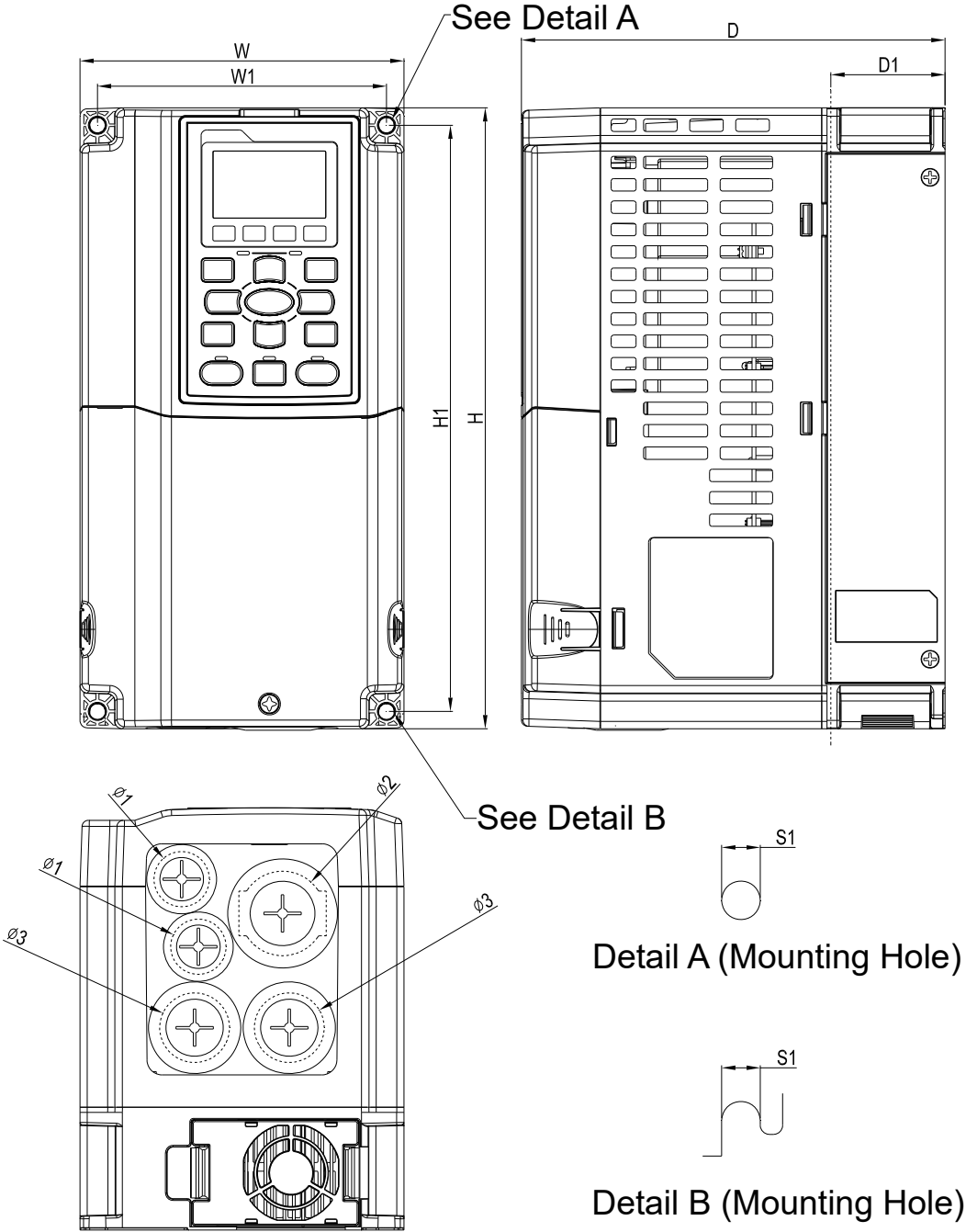

Figure 1-15

Unit: mm [inch]										
Frame	W	H	D	W1	H1	D1*	S1	$\phi 1$	$\phi 2$	$\phi 3$
A1	130.0 [5.12]	250.0 [9.84]	170.0 [6.69]	116.0 [4.57]	236.0 [9.29]	45.8 [1.80]	6.2 [0.24]	22.2 [0.87]	34.0 [1.34]	28.0 [1.10]

D1\*: Flange mounting

**Frame B**

VFD055C23A; VFD075C23A; VFD075C43A/E; VFD110C23A; VFD110C43A/E; VFD150C43A/E;  
 VFD055C53A-21; VFD075C53A-21; VFD110C53A-21; VFD150C53A-21

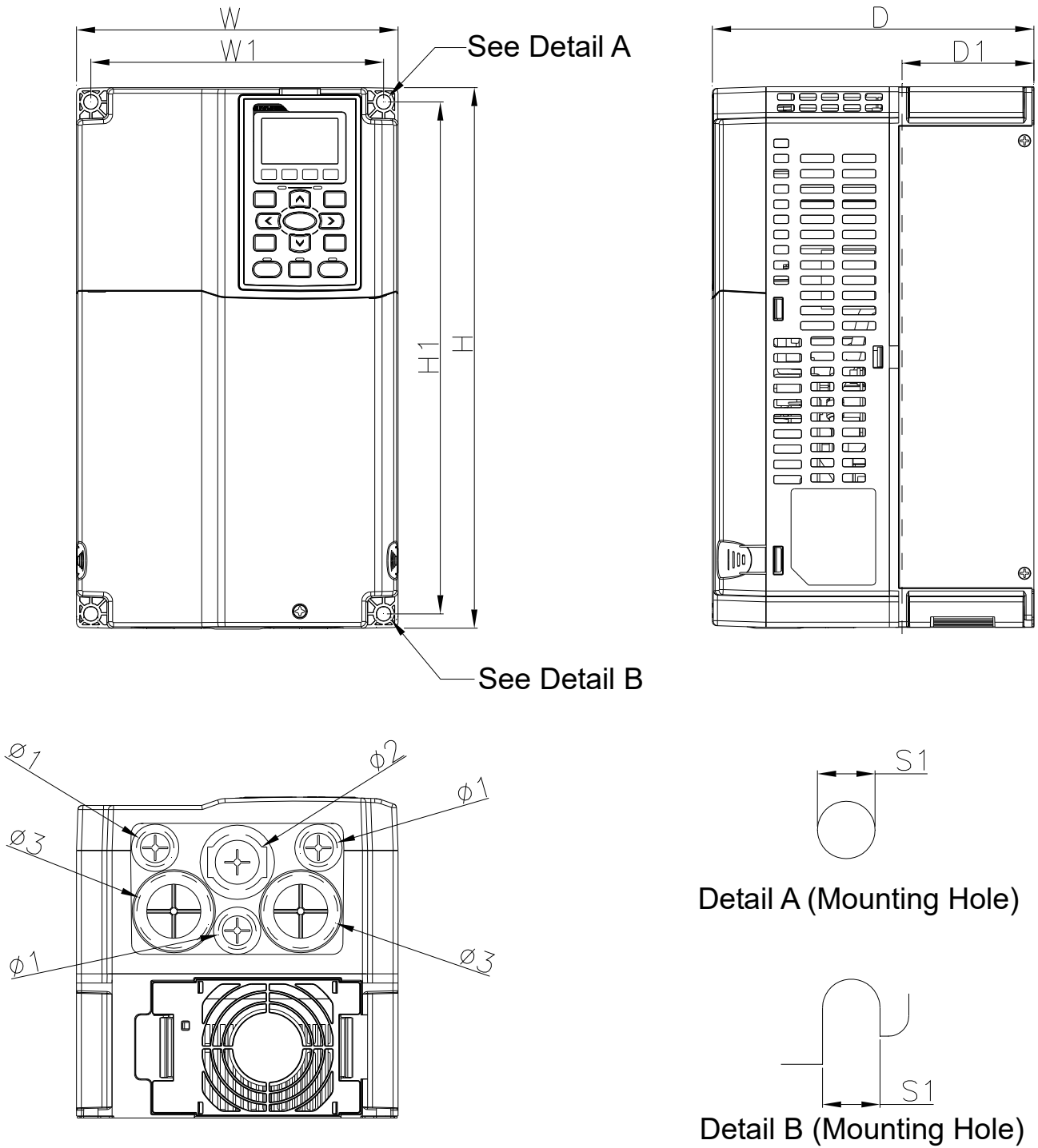

Figure 1-16

Unit: mm [inch]

Frame	W	H	D	W1	H1	D1*	S1	$\phi 1$	$\phi 2$	$\phi 3$
B1	190.0 [7.48]	320.0 [12.60]	190.0 [7.48]	173.0 [6.81]	303.0 [11.93]	77.9 [3.07]	8.5 [0.33]	22.2 [0.87]	34.0 [1.34]	43.8 [1.72]

D1\*: Flange mounting

**Frame C**

VFD150C23A; VFD185C23A; VFD185C43A/E; VFD220C23A; VFD220C43A/E; VFD300C43A/E;  
 VFD185C63B-21; VFD220C63B-21; VFD300C63B-21; VFD370C63B-21

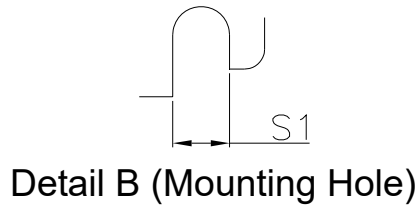
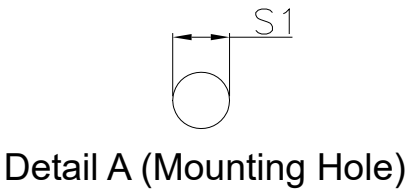
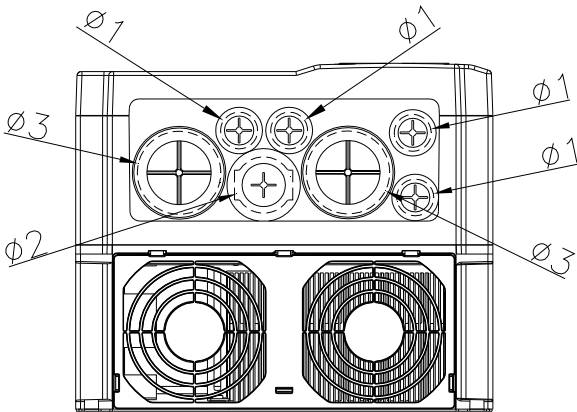
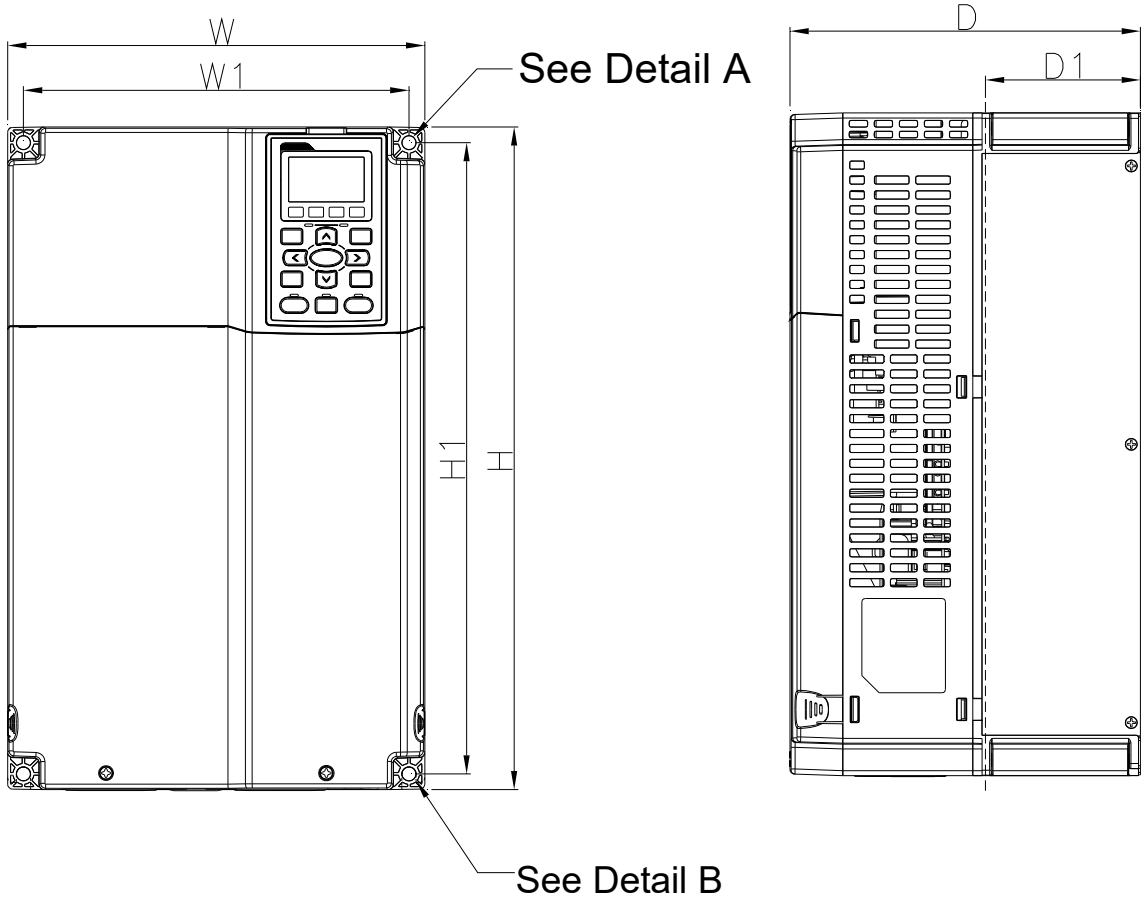

Figure 1-17

Unit: mm [inch]

Frame	W	H	D	W1	H1	D1*	S1	$\Phi 1$	$\Phi 2$	$\Phi 3$
C1	250.0 [9.84]	400.0 [15.75]	210.0 [8.27]	231.0 [9.09]	381.0 [15.00]	92.9 [3.66]	8.5 [0.33]	22.2 [0.87]	34.0 [1.34]	50.0 [1.97]

D1\*: Flange mounting

Frame D0

D0-1: VFD370C43S; VFD450C43S

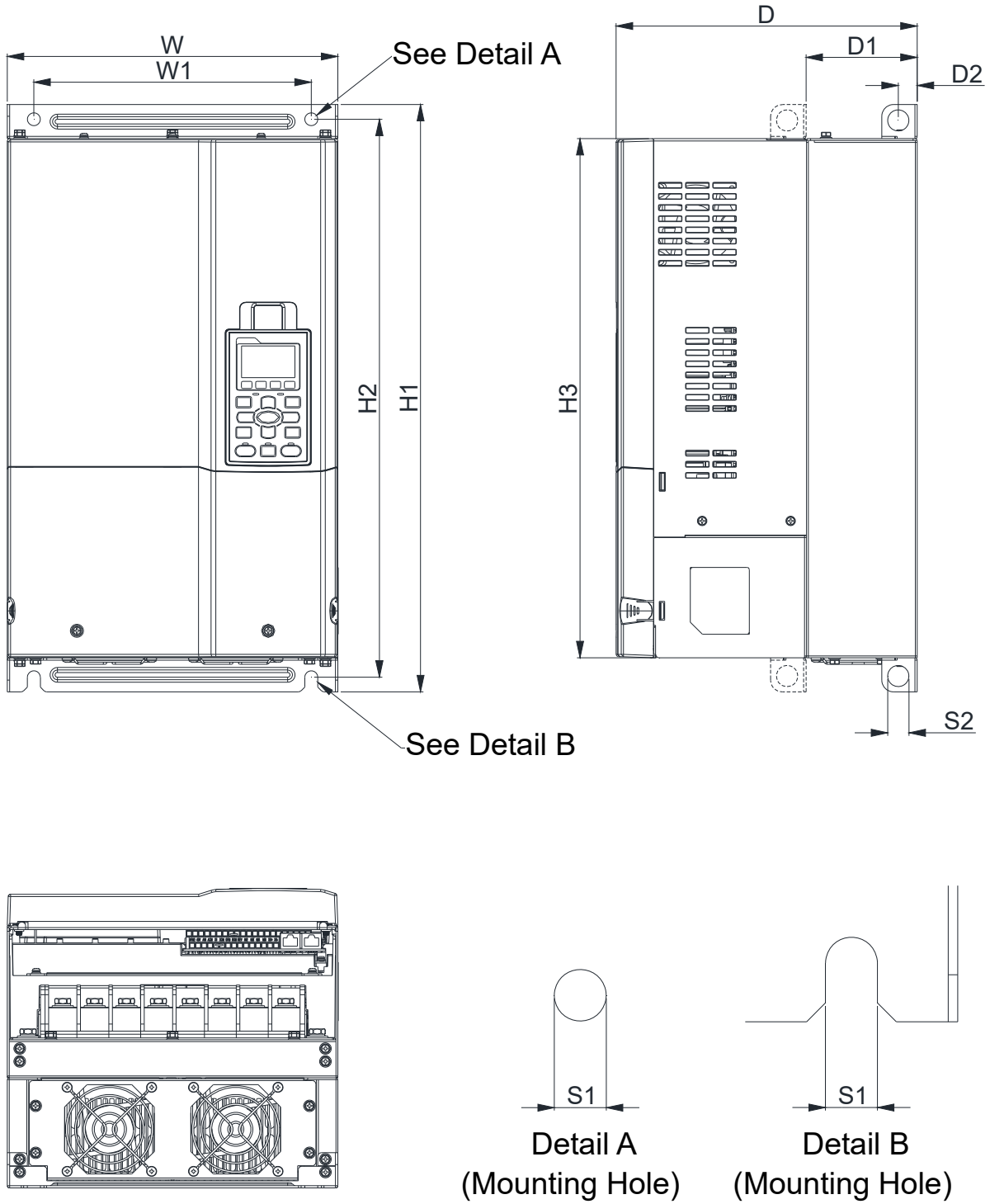

Figure 1-18

Unit: mm [inch]

Frame	W	H1	D	W1	H2	H3	D1*	D2	S1	S2
D0-1	280.0 [11.02]	500.0 [19.69]	255.0 [10.04]	235.0 [9.25]	475.0 [18.70]	442.0 [17.40]	94.2 [3.71]	16.0 [0.63]	11.0 [0.43]	18.0 [0.71]

D1\*: Flange mounting



Frame D0

D0-2: VFD370C43U; VFD450C43U

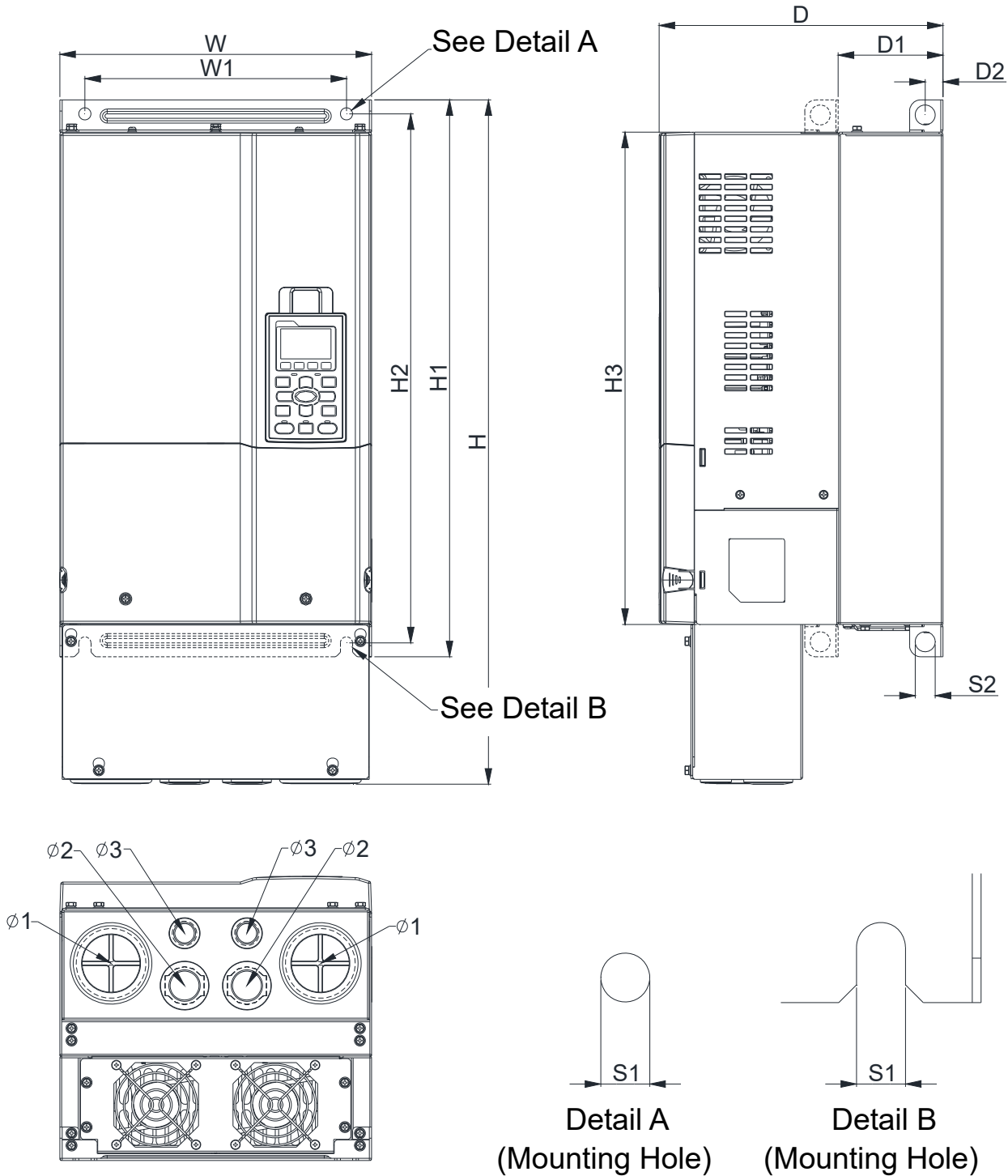

Figure 1-19

Frame	W	H	D	W1	H1	H2	H3	D1*	D2	S1	S2	Unit: mm [inch]		
												Φ1	Φ2	Φ3
D0-2	280.0 [11.02]	614.4 [24.19]	255.0 [10.04]	235.0 [9.25]	500.0 [19.69]	475.0 [18.70]	442.0 [17.40]	94.2 [3.71]	16.0 [0.63]	11.0 [0.43]	18.0 [0.71]	62.7 [2.47]	34.0 [1.34]	22.0 [0.87]

D1\*: Flange mounting

Frame D

D1: VFD300C23A; VFD370C23A; VFD550C43A; VFD750C43A; VFD450C63B-00; VFD550C63B-00

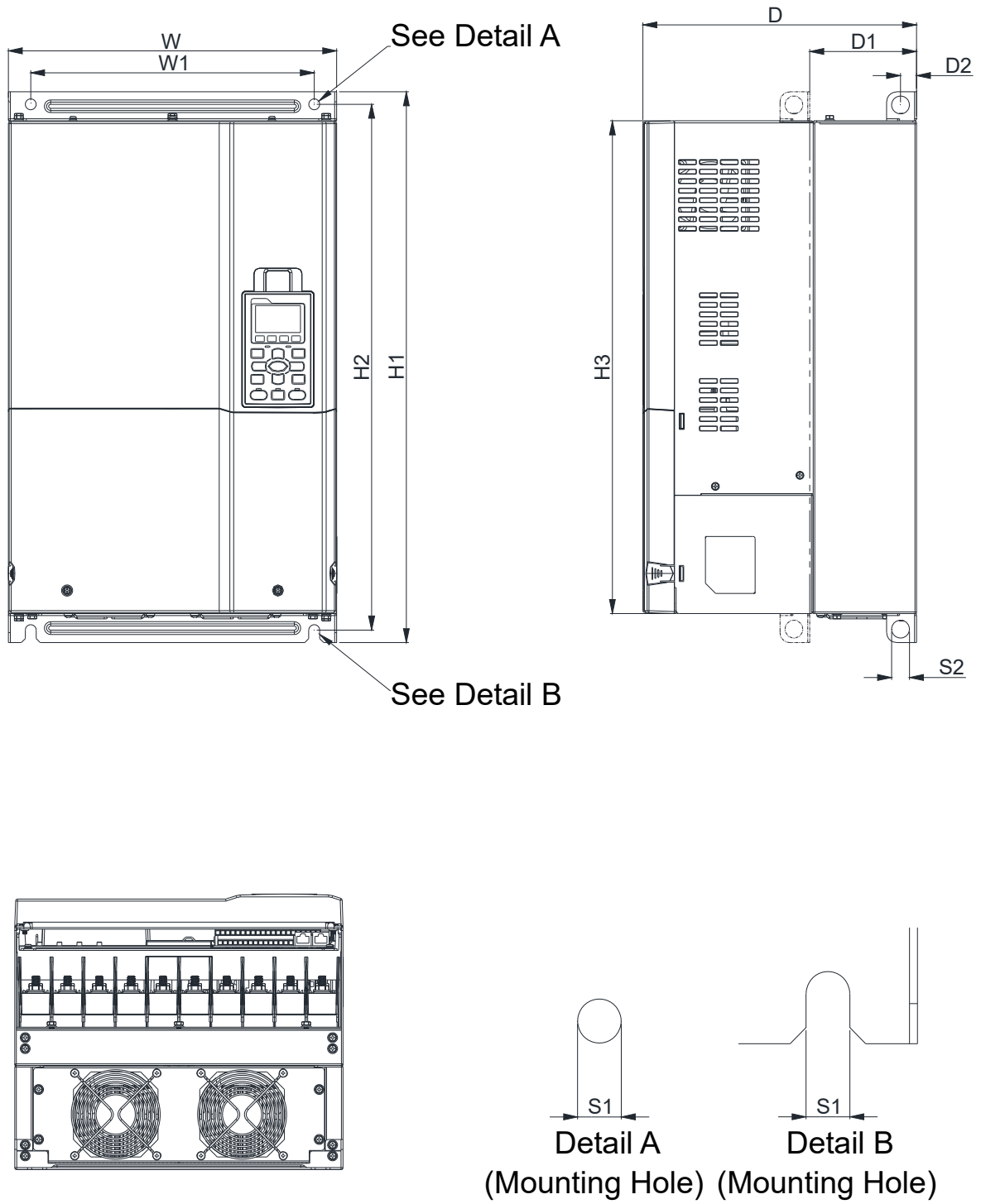

Figure 1-20

Unit: mm [inch]

Frame	W	H	D	W1	H1	H2	H3	D1*	D2	S1	S2	Φ1	Φ2	Φ3
D1	330.0 [12.99]	-	275.0 [10.83]	285.0 [11.22]	550.0 [21.65]	525.0 [20.67]	492.0 [19.37]	107.2 [4.22]	16.0 [0.63]	11.0 [0.43]	18.0 [0.71]	-	-	-

D1\*: Flange mounting

Frame D

D2: VFD300C23E; VFD370C23E; VFD550C43E; VFD750C43E; VFD450C63B-21; VFD550C63B-21

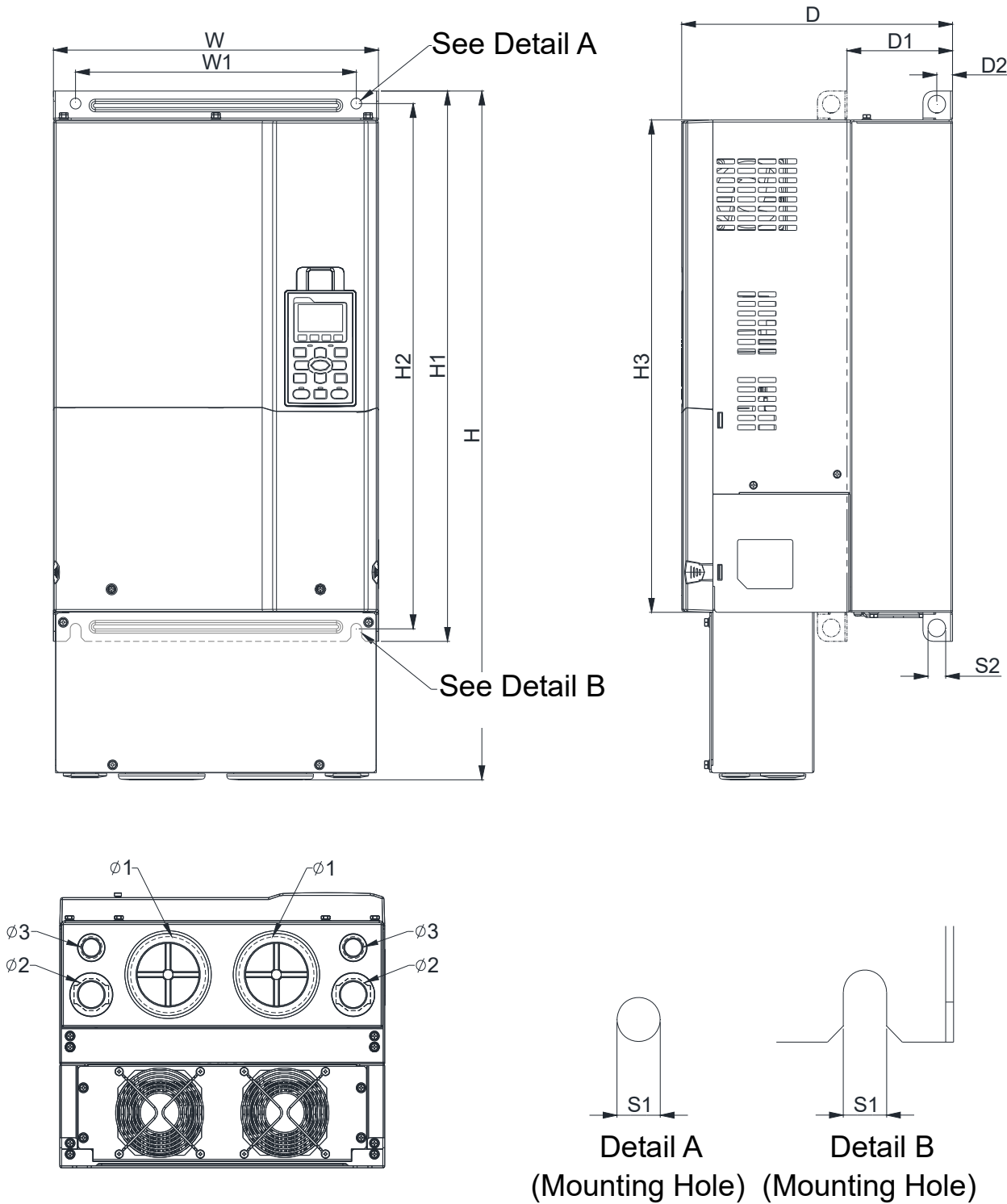

Figure 1-21

Unit: mm [inch]

Frame	W	H	D	W1	H1	H2	H3	D1*	D2	S1	S2	Ø1	Ø2	Ø3
D2	330.0 [12.99]	688.3 [27.10]	275.0 [10.83]	285.0 [11.22]	550.0 [21.65]	525.0 [20.67]	492.0 [19.37]	107.2 [4.22]	16.0 [0.63]	11.0 [0.43]	18.0 [0.71]	76.2 [3.00]	34.0 [1.34]	22.0 [0.87]

D1\*: Flange mounting

**Frame E**

E1: VFD450C23A; VFD550C23A; VFD750C23A; VFD900C43A; VFD1100C43A; VFD750C63B-00; VFD900C63B-00; VFD1100C63B-00; VFD1320C63B-00

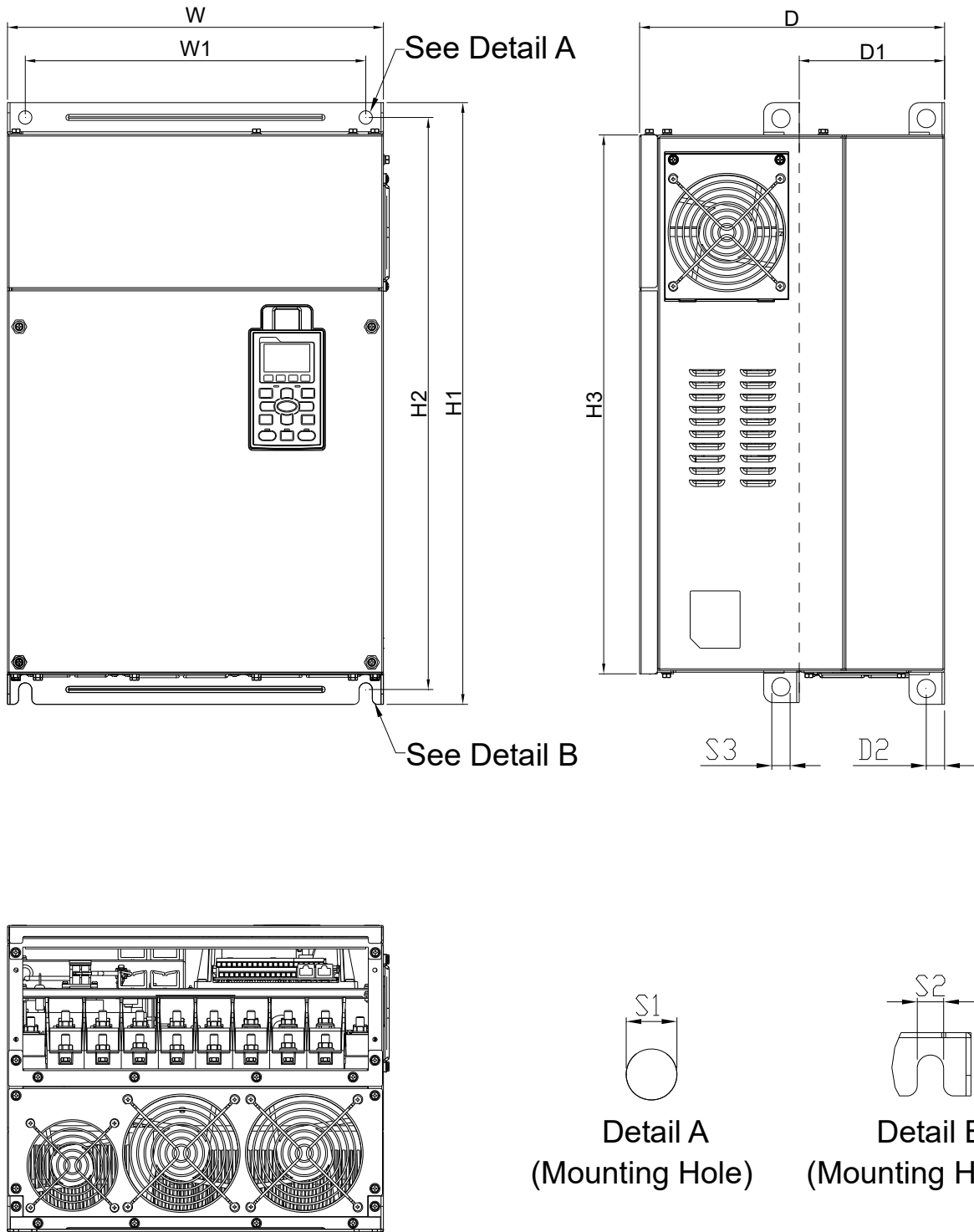

Figure 1-22

Unit: mm [inch]

Frame	W	H	D	W1	H1	H2	H3	D1*	D2	S1, S2	S3	Φ1	Φ2	Φ3
E1	370.0 [14.57]	-	300.0 [11.81]	335.0 [13.19]	589 [23.19]	560.0 [22.05]	528.0 [20.80]	143.0 [5.63]	18.0 [0.71]	13.0 [0.51]	18.0 [0.71]	-	-	-

D1\*: Flange mounting

**Frame E**

E2: VFD450C23E; VFD550C23E; VFD750C23E; VFD900C43E; VFD1100C43E; VFD750C63B-21; VFD900C63B-21; VFD1100C63B-21; VFD1320C63B-21

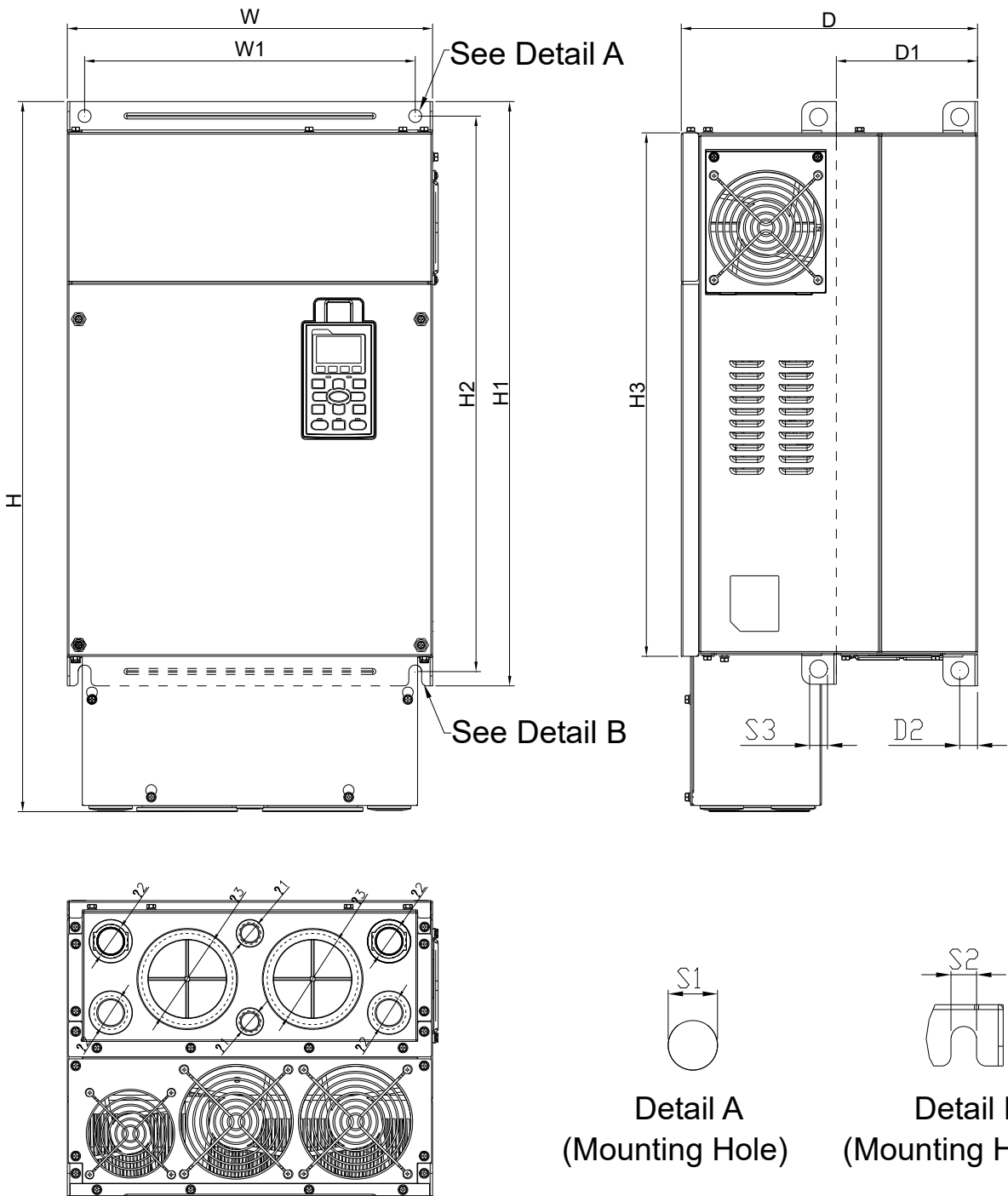

Figure 1-23

Unit: mm [inch]

Frame	W	H	D	W1	H1	H2	H3	D1*	D2	S1, S2	S3	Φ1	Φ2	Φ3
E2	370.0 [14.57]	715.8 [28.18]	300.0 [11.81]	335.0 [13.19]	589 [23.19]	560.0 [22.05]	528.0 [20.80]	143.0 [5.63]	18.0 [0.71]	13.0 [0.51]	18.0 [0.71]	22.0 [0.87]	34.0 [1.34]	92.0 [3.62]

D1\*: Flange mounting

Frame F

F1: VFD900C23A; VFD1320C43A; VFD1600C43A; VFD1600C63B-00; VFD2000C63B-00

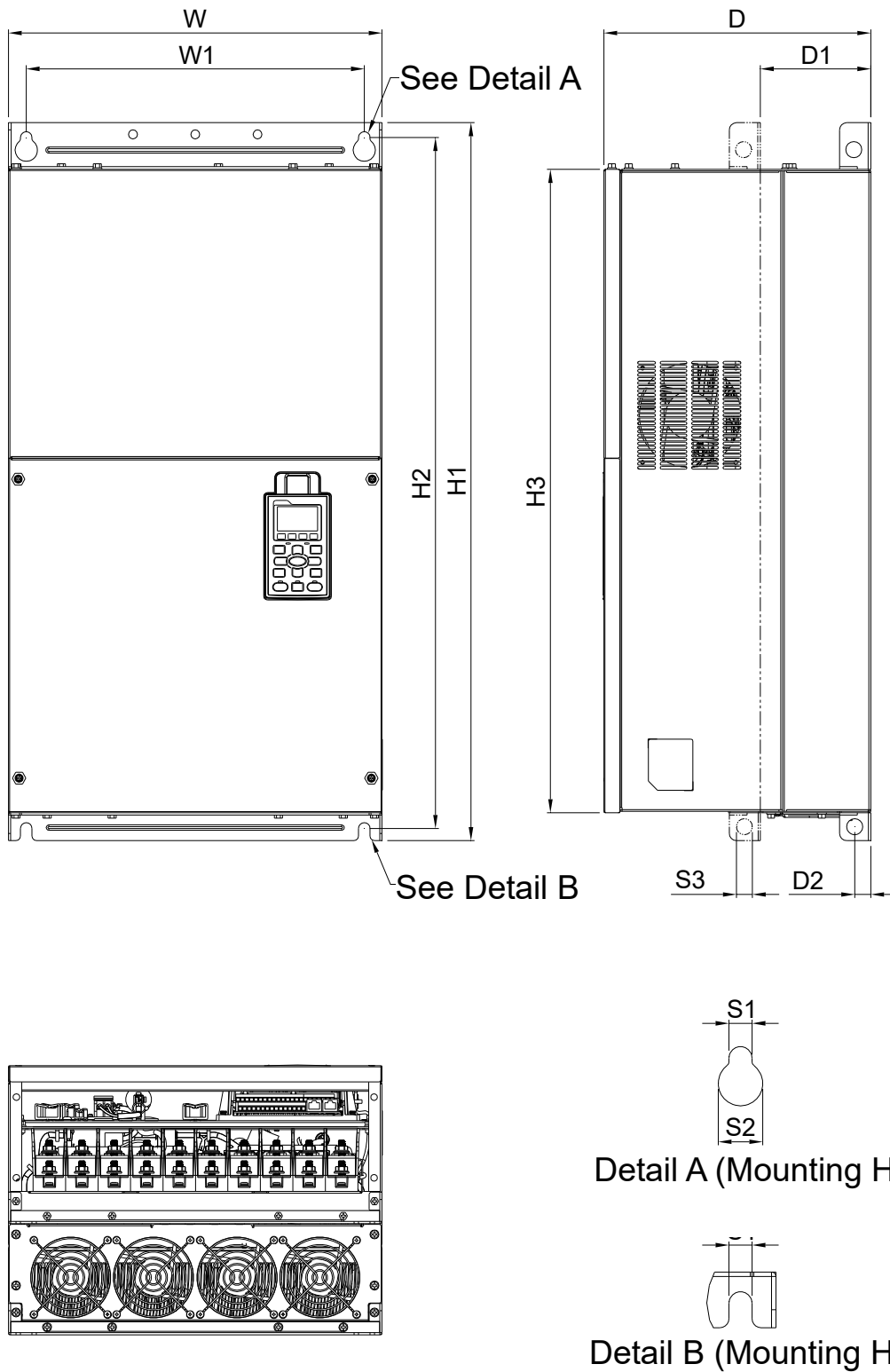

Figure 1-24

Unit: mm [inch]

Frame	W	H	D	W1	H1	H2	H3	D1*	D2	S1	S2	S3
F1	420.0 [16.54]	-	300.0 [11.81]	380.0 [14.96]	800.0 [31.50]	770.0 [30.32]	717.0 [28.23]	124.0 [4.88]	18.0 [0.71]	13.0 [0.51]	25.0 [0.98]	18.0 [0.71]

D1\*: Flange mounting

Frame F

F2: VFD900C23E; VFD1320C43E; VFD1600C43E; VFD1600C63B-21; VFD2000C63B-21

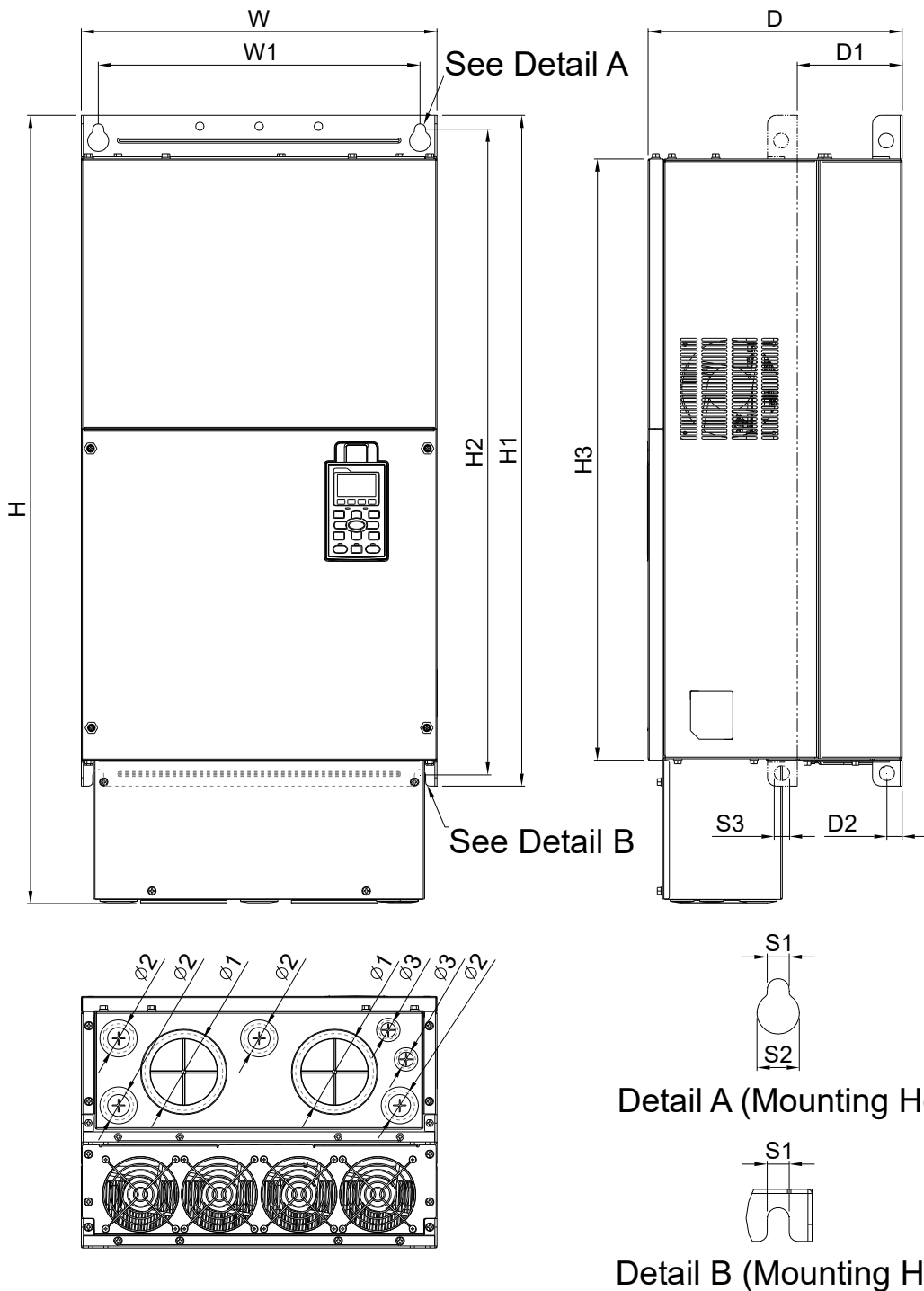

Figure 1-25

Unit: mm [inch]

Frame	W	H	D	W1	H1	H2	H3	D1*	D2	S1	S2	S3
F2	420.0 [16.54]	940.0 [37.00]	300.0 [11.81]	380.0 [14.96]	800.0 [31.50]	770.0 [30.32]	717.0 [28.23]	124.0 [4.88]	18.0 [0.71]	13.0 [0.51]	25.0 [0.98]	18.0 [0.71]
Frame	Φ1	Φ2	Φ3									
F2	92.0 [3.62]	35.0 [1.38]	22.0 [0.87]									

D1\*: Flange mounting



Frame G

G1: VFD1850C43A; VFD2200C43A; VFD2500C63B-00; VFD3150C63B-00

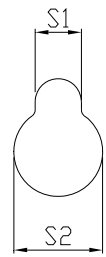
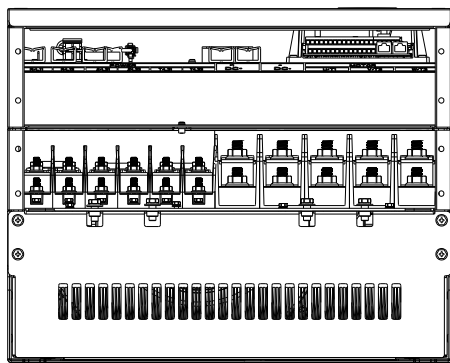
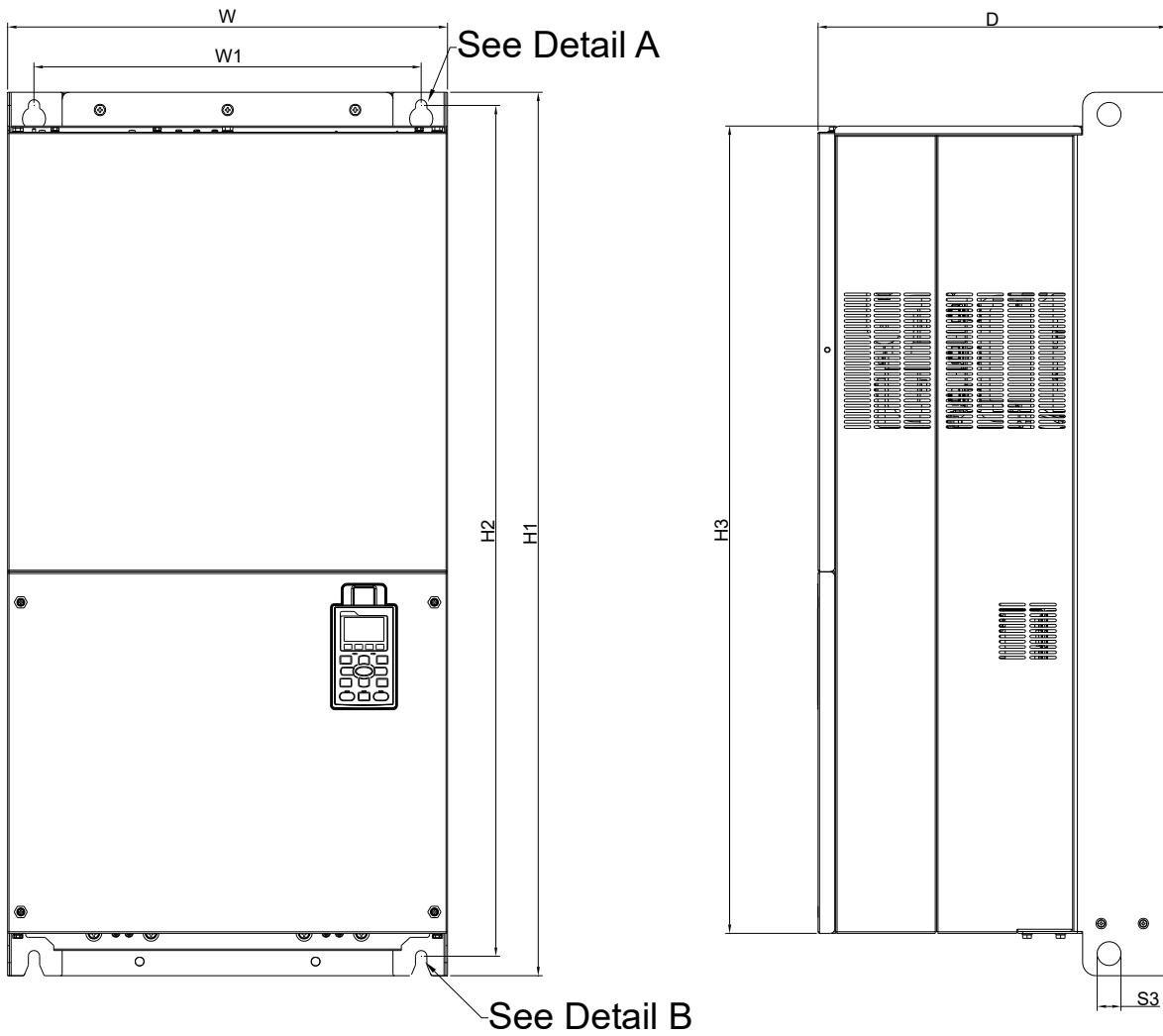

Detail A  
(Mounting Hole)

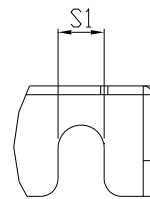

Detail B  
(Mounting Hole)

Figure 1-26

Unit: mm [inch]

Frame	W	H	D	W1	H1	H2	H3	S1	S2	S3	Φ1	Φ2	Φ3
G1	500.0 [19.69]	-	397.0 [15.63]	440.0 [217.32]	1000.0 [39.37]	963.0 [37.91]	913.6 [35.97]	13.0 [0.51]	26.5 [1.04]	27.0 [1.06]	-	-	-

Frame G

G2: VFD1850C43E; VFD2200C43E; VFD2500C63B-21; VFD3150C63B-21

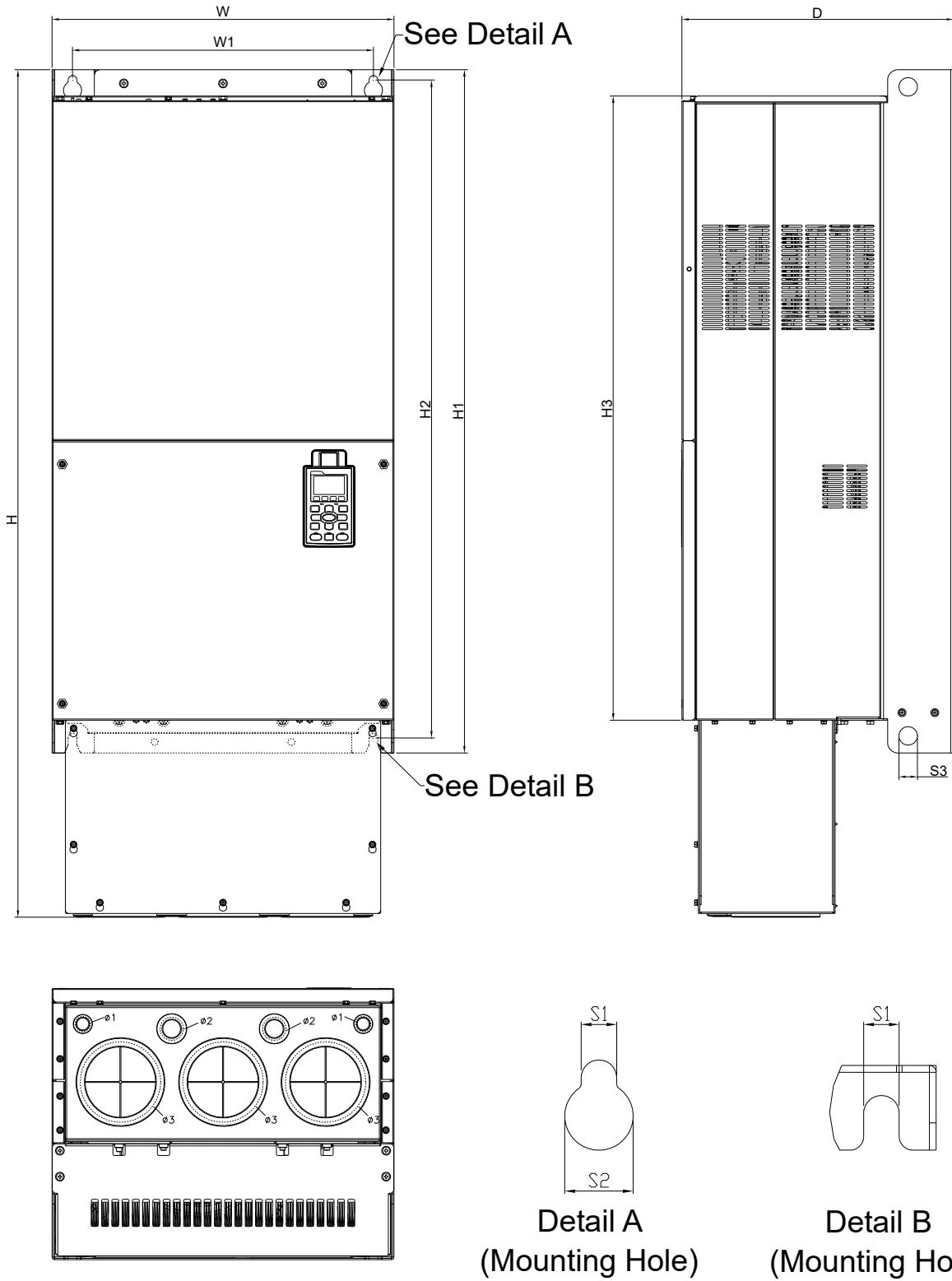

Figure 1-27

Unit: mm [inch]

Frame	W	H	D	W1	H1	H2	H3	S1	S2	S3	Φ1	Φ2	Φ3
G2	500.0 [19.69]	1240.2 [48.83]	397.0 [15.63]	440.0 [217.32]	1000.0 [39.37]	963.0 [37.91]	913.6 [35.97]	13.0 [0.51]	26.5 [1.04]	27.0 [1.06]	22.0 [0.87]	34.0 [1.34]	117.5 [4.63]

Frame H

H1: VFD2800C43A; VFD3150C43A; VFD3550C43A; VFD4500C43A; VFD4000C63B-00;  
 VFD4500C63B-00; VFD5600C63B-00; VFD6300C63B-00

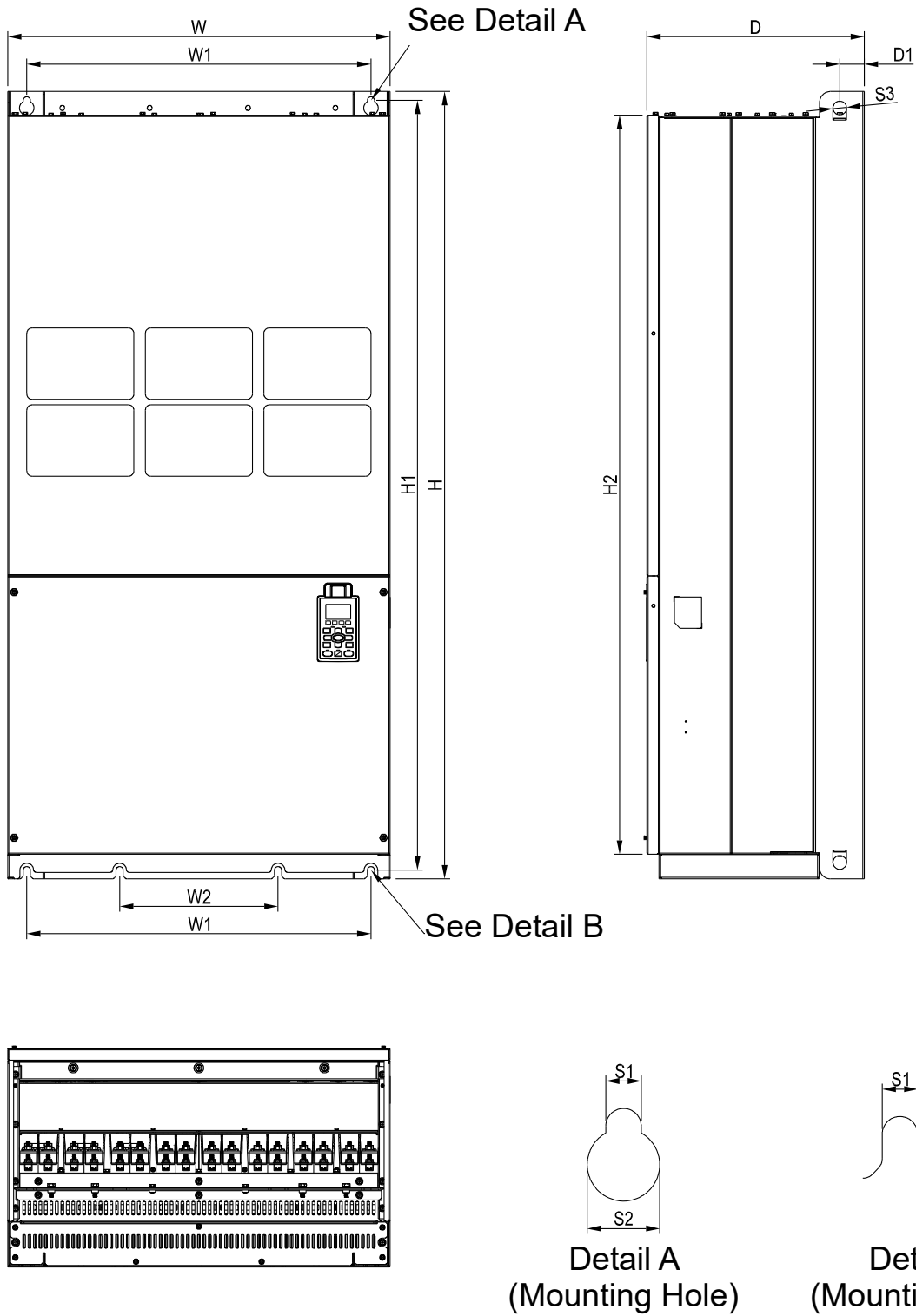

Figure 1-28

Unit: mm [inch]

Frame	W	H	D	W1	W2	W3	W4	W5	W6	H1	H2	H3	H4
H1	700.0 [27.56]	1435.0 [56.5]	398.0 [15.67]	630.0 [24.8]	290.0 [11.42]	-	-	-	-	1403.0 [55.24]	1346.6 [53.02]	-	-
Frame	H5	D1	D2	D3	D4	D5	D6	S1	S2	S3	Φ1	Φ2	Φ3
H1	-	45.0 [1.77]	-	-	-	-	-	13.0 [0.51]	26.5 [1.04]	25.0 [0.98]	-	-	-

Frame H

H2: VFD2800C43E-1; VFD3150C43E-1; VFD3550C43E-1; VFD4500C43E-1

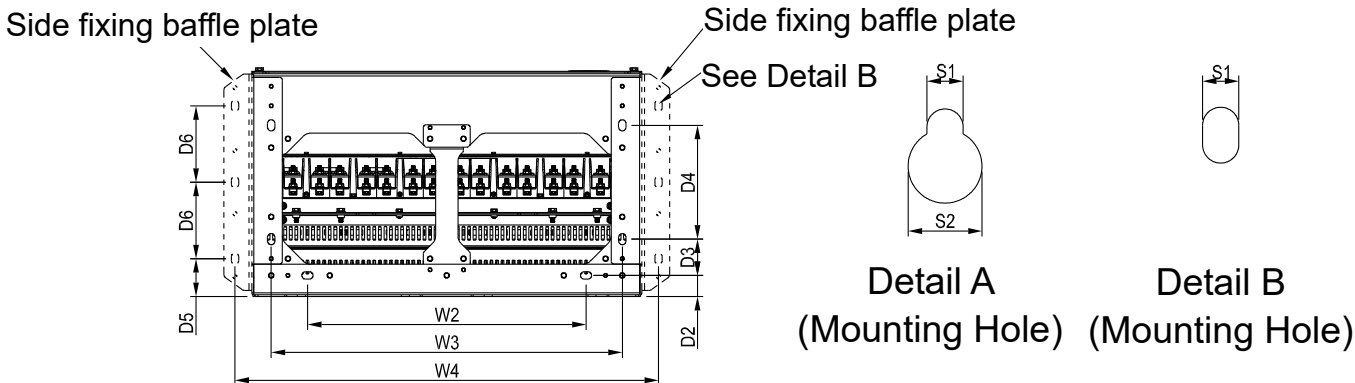
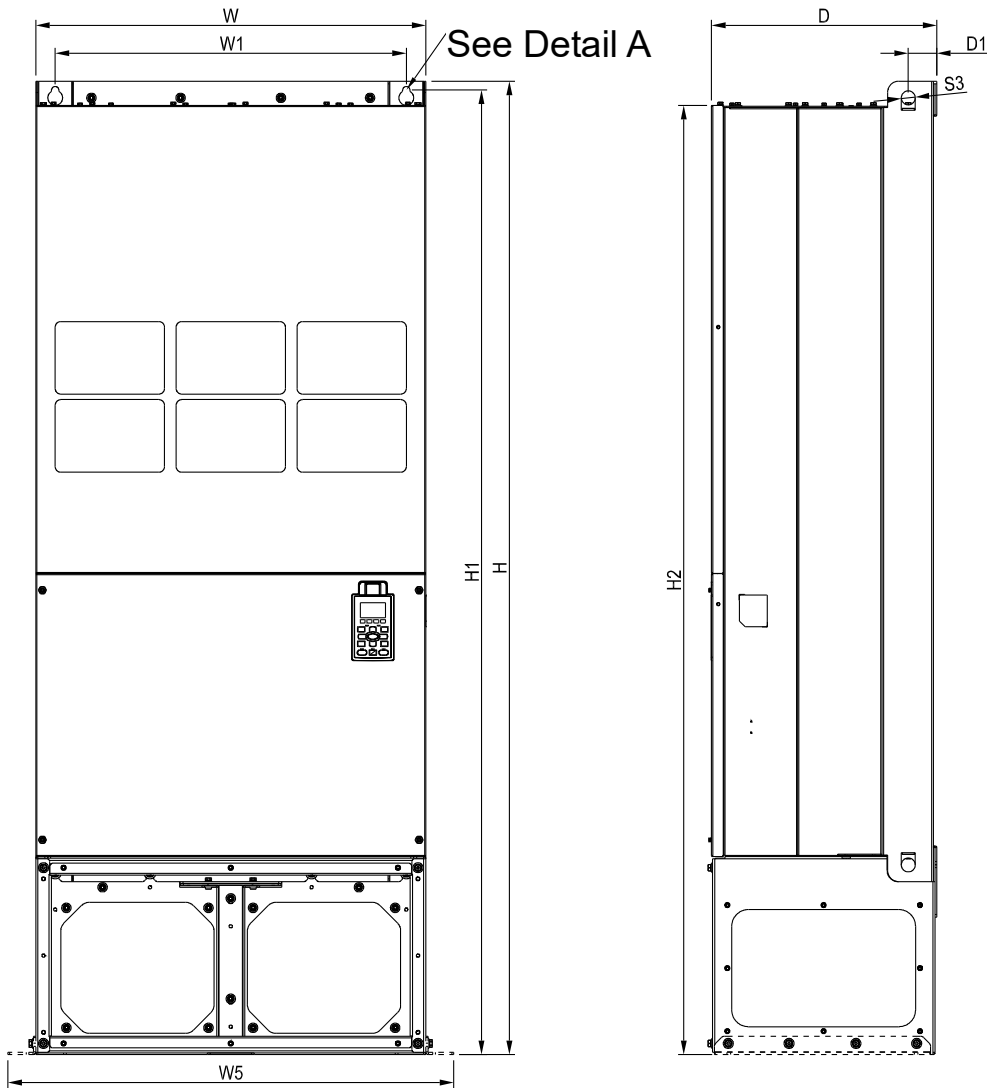

Figure 1-29

Unit: mm [inch]													
Frame	W	H	D	W1	W2	W3	W4	W5	W6	H1	H2	H3	H4
H2	700.0 [27.56]	1745.0 [68.70]	404.0 [15.91]	630.0 [24.8]	500.0 [19.69]	630.0 [24.8]	760.0 [29.92]	800.0 [31.5]	-	1729.0 [68.07]	1701.6 [66.99]	-	-
Frame	H5	D1	D2	D3	D4	D5	D6	S1	S2	S3	Φ1	Φ2	Φ3
H2	-	51.0 [2.01]	38.0 [1.50]	65.0 [2.56]	204.0 [8.03]	68.0 [2.68]	137.0 [5.39]	13.0 [0.51]	26.5 [1.04]	25.0 [0.98]	-	-	-

Frame H

H3: VFD2800C43E; VFD3150C43E; VFD3550C43E

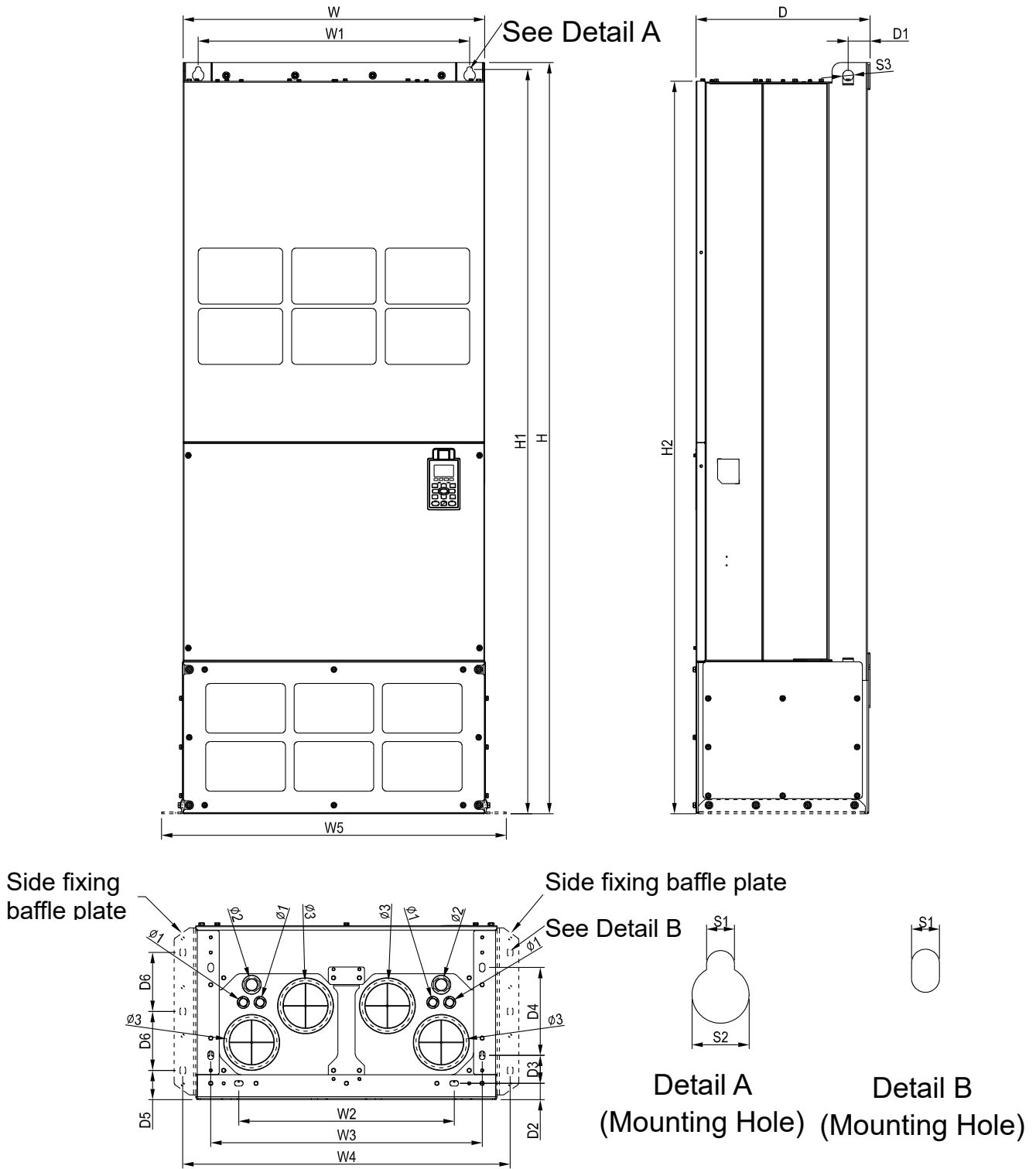

Figure 1-30

Unit: mm [inch]

Frame	W	H	D	W1	W2	W3	W4	W5	W6	H1	H2	H3	H4
H3	700.0 [27.56]	1745.0 [68.70]	404.0 [15.91]	630.0 [24.8]	500.0 [19.69]	630.0 [24.8]	760.0 [29.92]	800.0 [31.5]	-	1729.0 [68.07]	1701.6 [66.99]	-	-
Frame	H5	D1	D2	D3	D4	D5	D6	S1	S2	S3	$\phi_1$	$\phi_2$	$\phi_3$
H3	-	51.0 [2.01]	38.0 [1.50]	65.0 [2.56]	204.0 [8.03]	68.0 [2.68]	137.0 [5.39]	13.0 [0.51]	26.5 [1.04]	25.0 [0.98]	22.0 [0.87]	34.0 [1.34]	117.5 [4.63]

690V Frame H

H2: VFD4000C63B-21; VFD4500C63B-21; VFD5600C63B-21; VFD6300C63B-21

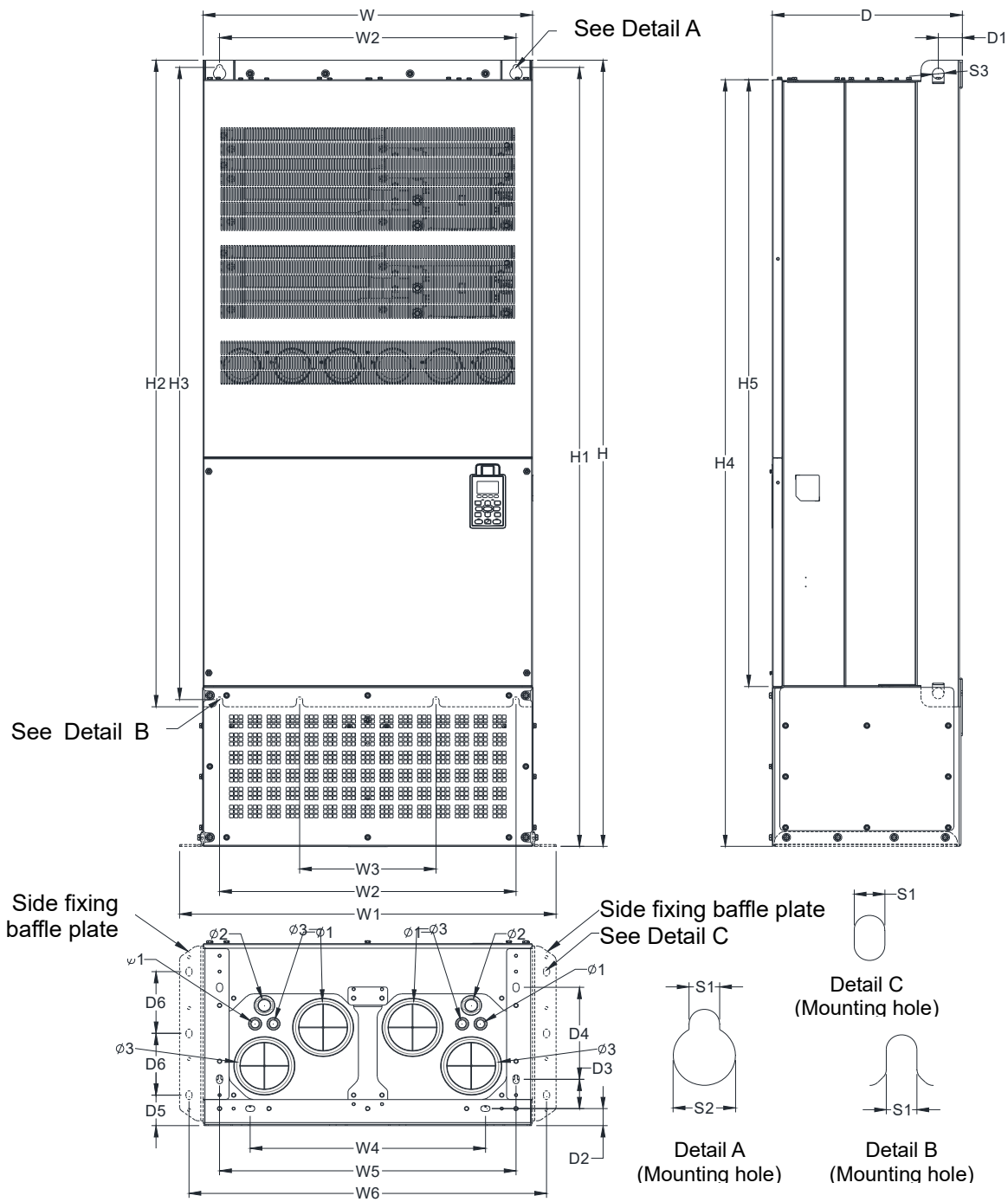

Figure 1-31

Unit: mm [inch]

Frame	W	H	D	W1	W2	W3	W4	W5	W6	H1	H2	H3	H4
H2	700.0 [27.56]	1745.0 [68.70]	404.0 [15.91]	630.0 [24.8]	500.0 [19.69]	630.0 [24.8]	760.0 [29.92]	800.0 [31.5]	-	1729.0 [68.07]	1701.6 [66.99]	-	-
Frame	H5	D1	D2	D3	D4	D5	D6	S1	S2	S3	Φ1	Φ2	Φ3
H2	-	51.0 [2.01]	38.0 [1.50]	65.0 [2.56]	204.0 [8.03]	68.0 [2.68]	137.0 [5.39]	13.0 [0.51]	26.5 [1.04]	25.0 [0.98]	22.0 [0.87]	34.0 [1.34]	117.5 [4.63]

Digital Keypad

KPC-CC01

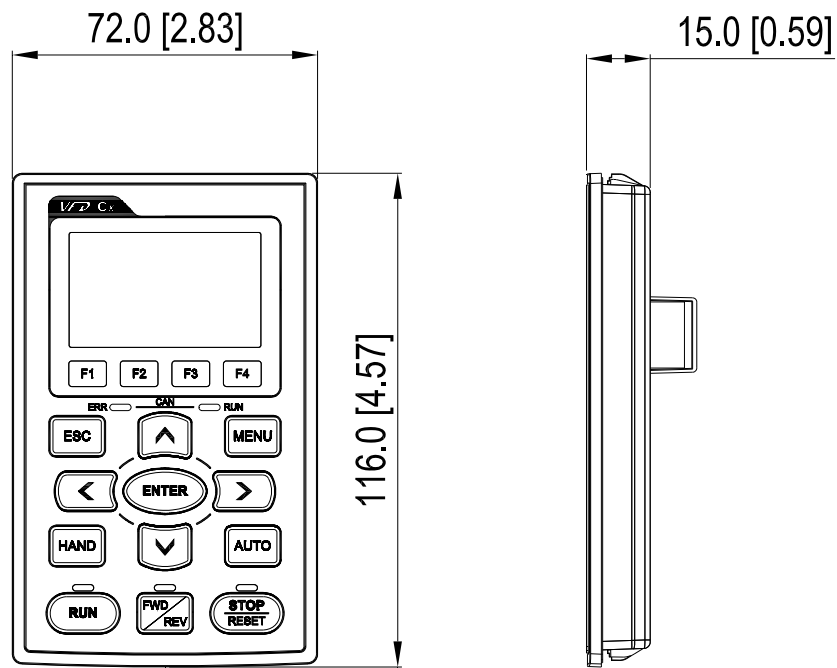

Figure 1-32

# ***Chapter 2 Installation***

---

2-1 Mounting Clearance

2-2 Air Flow and Power Dissipation



## 2-1 Mounting Clearance

- ❑ Prevent fiber particles, scraps of paper, shredded wood saw dust, metal particles, etc. from adhering to the heat sink
- ❑ Install the AC motor drive in a metal cabinet. When installing one drive below another one, use a metal separation between the AC motor drives to prevent mutual heating and to prevent the risk of fire accident.
- ❑ Install the AC motor drive in Pollution Degree 2 environments only:  
Normally only nonconductive pollution occurs and temporary conductivity caused by condensation is expected.

The appearances shown in the following figures are for reference only.

Airflow direction:  (Blue arrow) inflow  (Red arrow) outflow  Distance

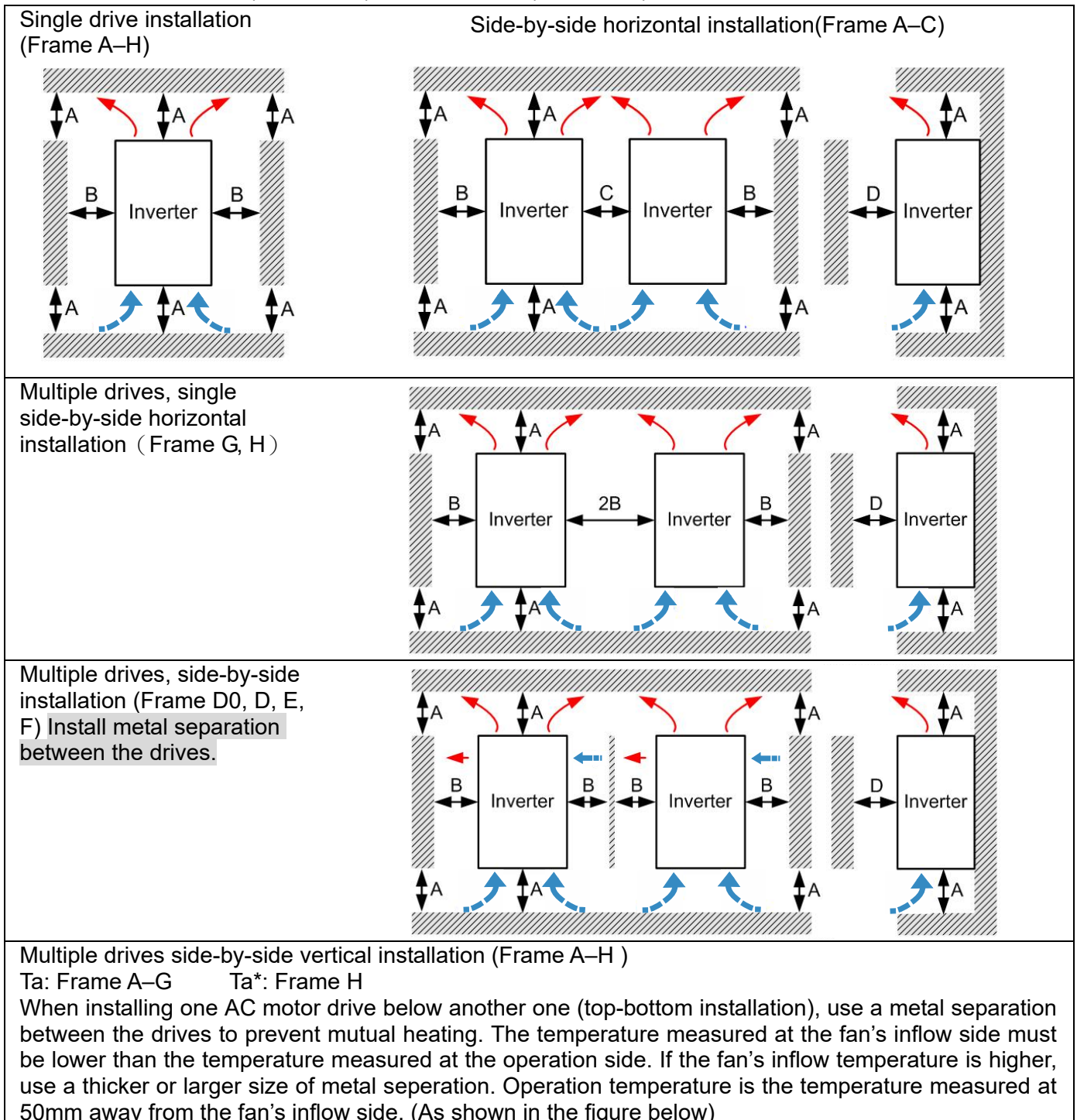

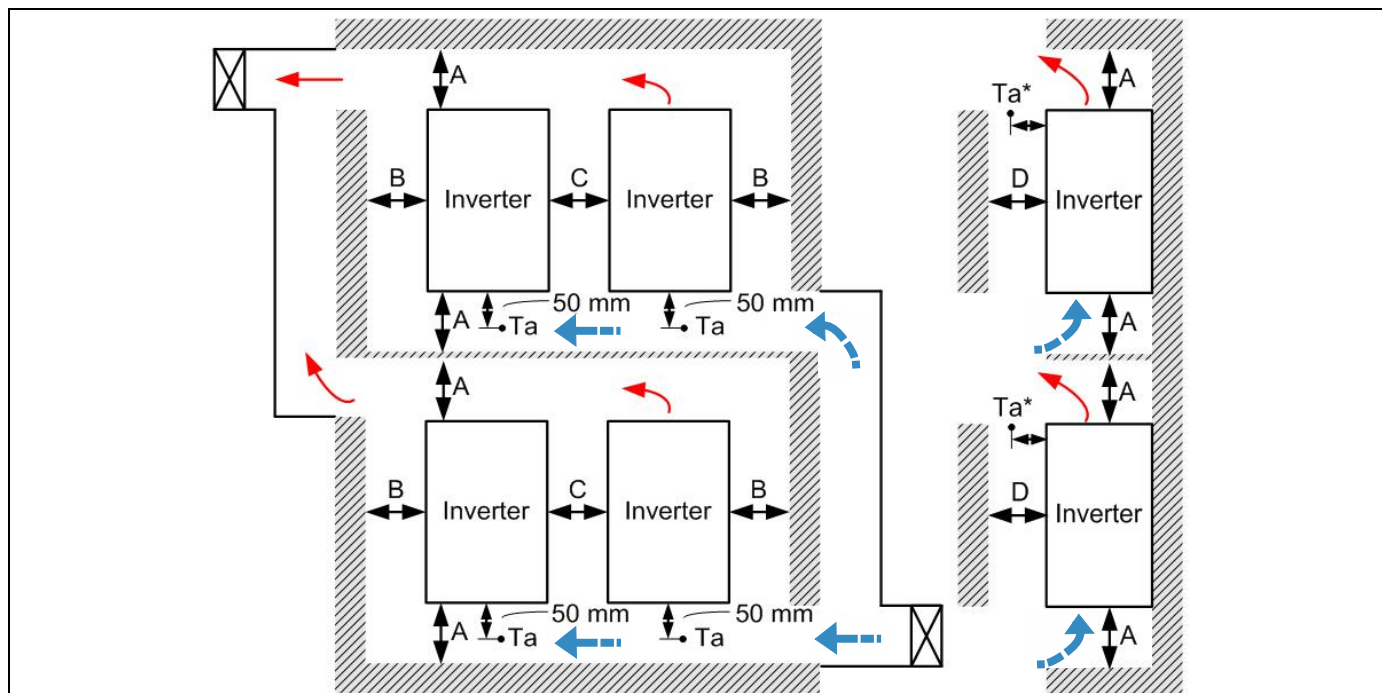

Frame	A [mm]	B [mm]	C [mm]	D [mm]
A-C	60	30	10	0
D0-F	100	50	-	0
G	200	100	-	0
H	350	0	0	200 (100, $T_a = T_a^* = 50^\circ\text{C}$ )

Frame A	VFD007C23A; VFD007C43A/E; VFD015C23A; VFD015C43A/E; VFD022C23A; VFD022C43A/E; VFD037C23A; VFD037C43A/E; VFD040C43A/E; VFD055C43A/E; VFD015C53A-21; VFD022C53A-21; VFD037C53A-21
Frame B	VFD055C23A; VFD75C23A; VFD075C43A/E; VFD110C23A; VFD110C43A/E; VFD150C43A/E; VFD055C53A-21; VFD075C53A-21; VFD110C53A-21; VFD150C53A-21
Frame C	VFD150C23A; VFD185C23A; VFD185C43A/E; VFD220C23A; VFD220C43A/E; VFD300C43A/E; VFD185C63B-21; VFD220C63B-21; VFD300C63B-21; VFD370C63B-21
Frame D0	VFD370C43S; VFD450C43S; VFD370C43U; VFD450C43U
Frame D	VFD300C23A/E; VFD370C23A/E; VFD550C43A/E; VFD750C43A/E; VFD450C63B-00; VFD550C63B-00; VFD450C63B-21; VFD550C63B-21
Frame E	VFD450C23A/E; VFD550C23A/E; VFD750C23A/E; VFD900C43A/E; VFD1100C43A/E; VFD750C63B-00; VFD900C63B-00; VFD1100C63B-00; VFD1320C63B-00; VFD750C63B-21; VFD900C63B-21; VFD1100C63B-21; VFD1320C63B-21
Frame F	VFD900C23A/E; VFD1320C43A/E; VFD1600C43A/E; VFD1600C63B-00; VFD2000C63B-00; VFD1600C63B-21; VFD2000C63B-21
Frame G	VFD1850C43A; VFD2200C43A; VFD1850C43E; VFD2200C43E; VFD2500C63B-00; VFD3150C63B-00; VFD2500C63B-21; VFD3150C63B-21
Frame H	VFD2800C43A; VFD3150C43A; VFD3550C43A; VFD4500C43A; VFD2800C43E-1; VFD3150C43E-1; VFD3550C43E-1; VFD4500C43E-1; VFD2800C43E; VFD3150C43E; VFD3550C43E; VFD4500C43E; VFD4000C63B-00; VFD4500C63B-00; VFD5600C63B-00; VFD6300C63B-00; VFD4000C63B-21; VFD4500C63B-21; VFD5600C63B-21; VFD6300C63B-21

**NOTE**

1. The minimum mounting clearances stated in the table above applies to AC motor drives frame A to D. A drive fails to follow the minimum mounting clearances may cause the fan to malfunction and heat dissipation problem.

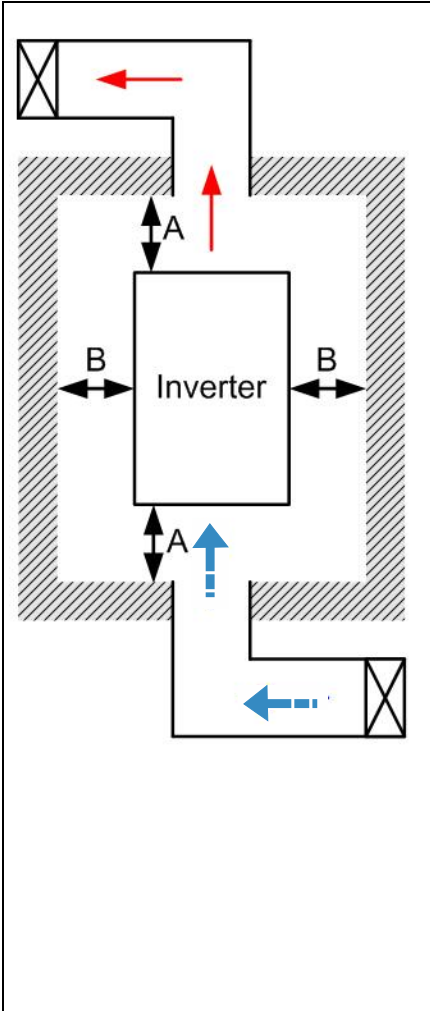

**NOTE**

- ※ The mounting clearances stated in the figure is for installing the drive in an open area. To install the drive in a confined space (such as cabinet or electric box), please follow the following three rules: (1) Keep the minimum mounting clearances. (2) Install a ventilation equipment or an air conditioner to keep surrounding temperature lower than operation temperature. (3) Refer to parameter setting and set up Pr. 00-16, Pr.00-17, and Pr. 06-55.
- ※ The following table shows the heat dissipation and the required air volume when installing a single drive in a confined space. When installing multiple drives, the required air volume shall be multiplied by the number of the drives.
- ※ Refer to the chart (Air flow rate for cooling) for ventilation equipment design and selection.
- ※ Refer to the chart (Power dissipation) for air conditioner design and selection.
- ※ Different control mode will affect the derating. See Pr. 06-55 for more information.
- ※ Ambient temperature derating curve shows the derating status in different temperature in relation to different protection level.
- ※ If UL Type 1 models need side by side installation, please remove top cover of FrameA–C, and please do not install conduit box of Frame D and above.
- ※ Suitable for Installation in a Compartment Handling Conditioned Air (Plenum).

## 2-2 Air Flow and Power Dissipation

Air flow rate for cooling							Power dissipation of AC motor drive		
Model No.	Flow Rate [cfm]			Flow Rate [m <sup>3</sup> /hr]			Power Dissipation [W]		
	External	Internal	Total	External	Internal	Total	Loss External (Heat sink)	Internal	Total
VFD007C23A	-	-	-	-	-	-	33	27	61
VFD015C23A	14	-	14	24	-	24	56	31	88
VFD022C23A	14	-	14	24	-	24	79	36	115
VFD037C23A	10	-	10	17	-	17	113	46	159
VFD055C23A	40	14	54	68	24	92	197	67	264
VFD075C23A	66	14	80	112	24	136	249	86	335
VFD110C23A	58	14	73	99	24	124	409	121	529
VFD150C23A	166	12	178	282	20	302	455	161	616
VFD185C23A	166	12	178	282	20	302	549	184	733
VFD220C23A	166	12	178	282	20	302	649	216	865
VFD300C23A/E	179	30	209	304	51	355	913	186	1099
VFD370C23A/E	179	30	209	304	51	355	1091	220	1311
VFD450C23A/E	228	73	301	387	124	511	1251	267	1518
VFD550C23A/E	228	73	301	387	124	511	1401	308	1709
VFD750C23A/E	246	73	319	418	124	542	1770	369	2139
VFD900C23A/E	224	112	336	381	190	571	2304	484	2788
VFD007C43A/E	-	-	-	-	-	-	33	25	59
VFD015C43A/E	-	-	-	-	-	-	45	29	74
VFD022C43A/E	14	-	14	24	-	24	71	33	104
VFD037C43A/E	10	-	10	17	-	17	103	38	141
VFD040C43A/E	10	-	10	17	-	17	116	42	158
VFD055C43A/E	10	-	10	17	-	17	134	46	180
VFD075C43A/E	40	14	54	68	24	92	216	76	292
VFD110C43A/E	66	14	80	112	24	136	287	93	380
VFD150C43A/E	58	14	73	99	24	124	396	122	518
VFD185C43A/E	99	21	120	168	36	204	369	138	507
VFD220C43A/E	99	21	120	168	36	204	476	158	635
VFD300C43A/E	126	21	147	214	36	250	655	211	866
VFD370C43S/U	179	30	209	304	51	355	809	184	993
VFD450C43S/U	179	30	209	304	51	355	929	218	1147
VFD550C43A/E	179	30	209	304	51	355	1156	257	1413
VFD750C43A/E	186	30	216	316	51	367	1408	334	1742
VFD900C43A/E	257	73	330	437	124	561	1693	399	2092
VFD1100C43A/E	223	73	296	379	124	503	2107	491	2599
VFD1320C43A/E	224	112	336	381	190	571	2502	579	3081
VFD1600C43A/E	289	112	401	491	190	681	3096	687	3783
VFD1850C43A/E	\		454	\		771	\		4589
VFD2200C43A/E			454			771			5772
VFD2800C43A/E			769			1307			6381
VFD3150C43A/E			769			1307			7156
VFD3550C43A/E			769			1307			8007
VFD4500C43A/E			769			1307			11894
VFD015C53A-21	-	-	-	-	-	-	39.5	13.0	53
VFD022C53A-21	-	-	-	-	-	-	55.0	22.0	77
VFD037C53A-21	0.006	-	0.006	13.6	-	13.6	86.8	42.7	130
VFD055C53A-21	0.019	0.007	0.026	40.0	14.5	54.5	124.6	67.9	193
VFD075C53A-21	0.019	0.007	0.026	40.0	14.5	54.5	143.5	119.0	263
VFD110C53A-21	0.019	0.007	0.026	40.0	14.5	54.5	222.2	162.8	385
VFD150C53A-21	0.019	0.007	0.026	40.0	14.5	54.5	308.5	216.5	525
VFD185C63B-21	90.0	21.3	111.4	153.0	36.2	189.2	317.5	145.0	462.5
VFD220C63B-21	90.0	21.3	111.4	153.0	36.2	189.2	408.2	141.8	550.0
VFD300C63B-21	90.0	21.3	111.4	153.0	36.2	189.2	492.7	257.3	750.0

Air flow rate for cooling							Power dissipation of AC motor drive		
Model No.	Flow Rate [cfm]			Flow Rate [m <sup>3</sup> /hr]			Power Dissipation [W]		
	External	Internal	Total	External	Internal	Total	Loss External (Heat sink)	Internal	Total
VFD370C63B-21	89.0	21.3	110.3	151.2	36.2	187.5	641.6	283.4	925.0
VFD450C63B-00/21	175.9	36.4	212.3	298.8	61.8	360.6	718.2	406.8	1125.0
VFD550C63B-00/21	175.9	36.4	212.3	298.8	61.8	360.6	890.1	484.9	1375.0
VFD750C63B-00/21	264.6	90.6	355.2	449.6	153.9	603.5	1356.0	519.0	1875.0
VFD900C63B-00/21	264.6	90.6	355.2	449.6	153.9	603.5	1652.8	597.2	2250.0
VFD1100C63B-00/21	264.6	90.6	355.2	449.6	153.9	603.5	1960.3	789.7	2750.0
VFD1320C63B-00/21	264.6	90.6	355.2	449.6	153.9	603.5	2230.8	1069.2	3300.0
VFD1600C63B-00/21	248.1	135.3	383.4	421.6	229.9	651.4	2627.3	1372.7	4000.0
VFD2000C63B-00/21	248.1	135.3	383.4	421.6	229.9	651.4	3415.0	1585.0	5000.0
VFD2500C63B-00/21	\		409.7	\		696.0	4751.7	1498.3	6250.0
VFD3150C63B-00/21			409.7			696.0	5695.4	2179.6	7875.0
VFD4000C63B-00/21			563.0			956.4	6796.2	3203.8	10000.0
VFD4500C63B-00/21			952.9			1618.9	7313.6	3936.4	11250.0
VFD5600C63B-00/21			952.9			1618.9	9553.4	4446.6	14000.0
VFD6300C63B-00			952.9			1618.9	11042.4	4707.6	15750.0
VFD6300C63B-21									
※ The required airflow shown in chart is for installing single drive in a confined space. ※ When installing the multiple drives, the required air volume should be the required air volume for single drive X the number of the drives.							※ The heat dissipation shown in the chart is for installing single drive in a confined space. ※ When installing the multiple drives, volume of heat dissipation should be the heat dissipated for single drive X the number of the drives. ※ Heat dissipation for each model is calculated by rated voltage, current and default carrier.		

# ***Chapter 3 Unpacking***

---

3-1 Unpacking

3-2 The Lifting Hook

The AC motor drive should be kept in the shipping carton or crate before installation. In order to retain the warranty coverage, the AC motor drive should be stored properly when it is not to be used for an extended period of time.

### 3-1 Unpacking

Follow these steps to unpack the AC motor drive:

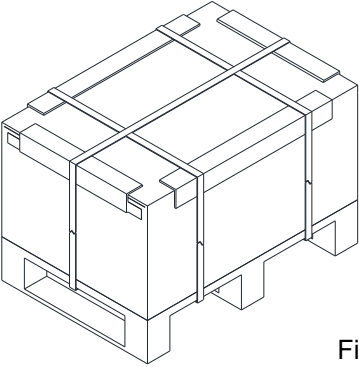
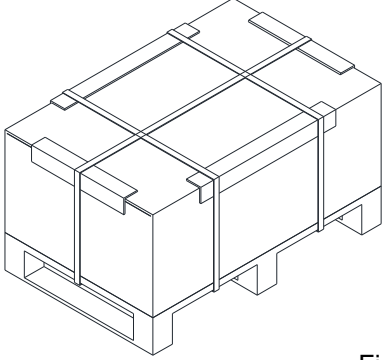
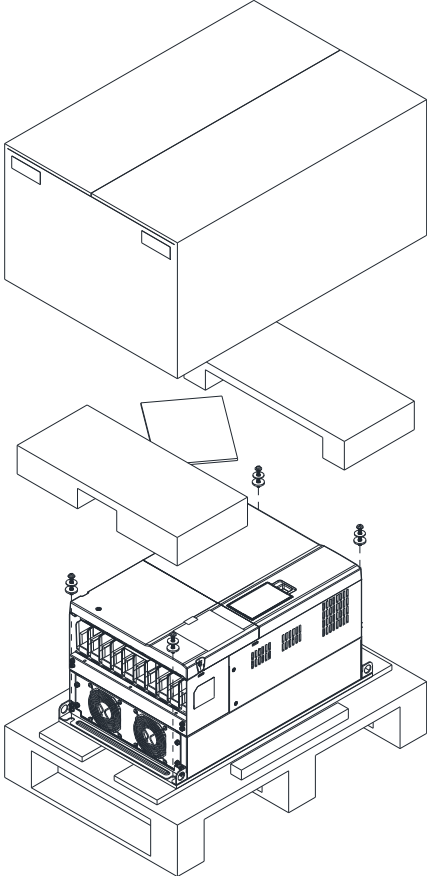
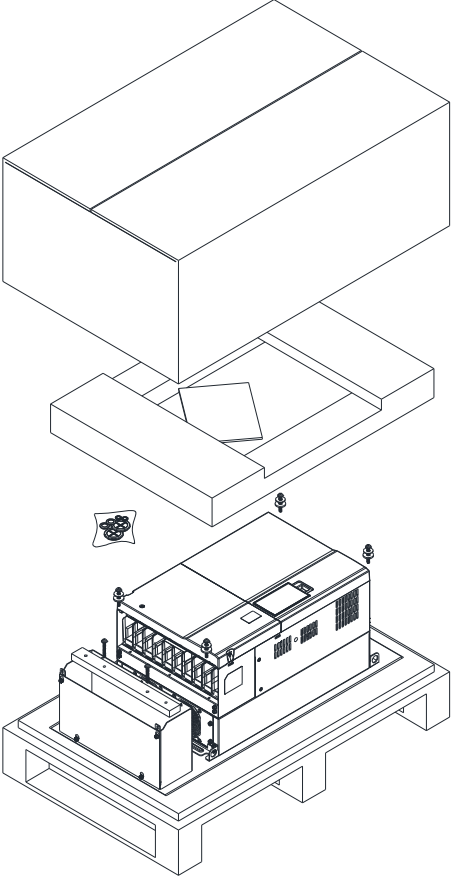
Frame D (carton version)	
<p>Unpacking 1 (VFDXXXCXXA, VFDXXXC63B-00) Cut the three pieces of packaging strap off.</p>  <p style="text-align: right;">Figure 3-1</p>	<p>Unpacking 2 (VFDXXXCXXE, VFDXXXC63B-21) Cut the three pieces of packaging strap off.</p>  <p style="text-align: right;">Figure 3-4</p>
<p>Remove the top cover, take out the EPEs and the manual, and then loosen the four screws.</p>  <p style="text-align: right;">Figure 3-2</p>	<p>Remove the top cover, take out the EPEs, rubber and the manual, and then loosen the six screws.</p>  <p style="text-align: right;">Figure 3-5</p>

Lift the drive by hooking the lifting hole. It is now ready for installation.

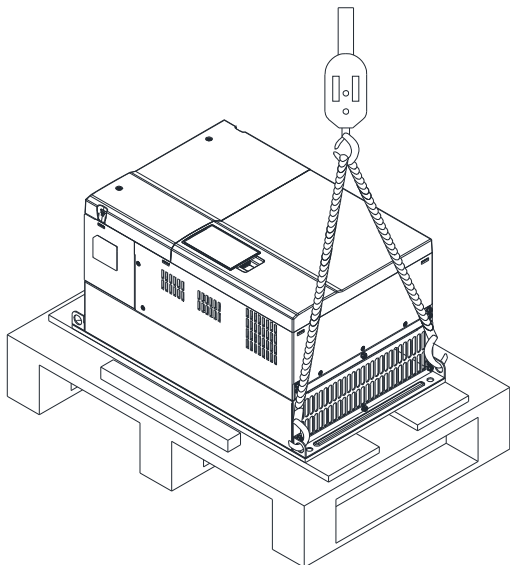

Figure 3-3

Lift the drive by hooking the lifting hole. It is now ready for installation.

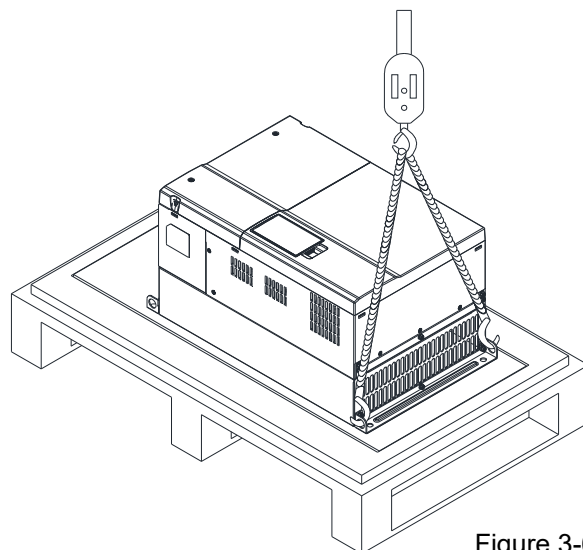

Figure 3-6



Frame D (crate version)

Unpacking 1 (VFDXXXCXXA, VFDXXXC63B-00)  
Loosen the 12 screws to open the top cover of the crate.

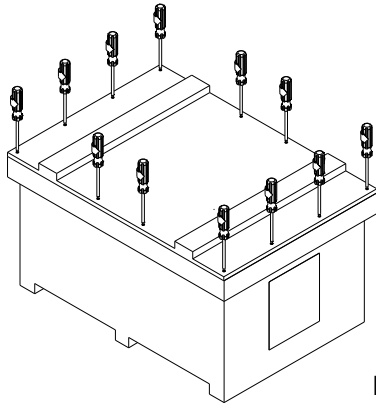

Figure 3-7

Unpacking 2 (VFDXXXCXXE, VFDXXXC63B-21)  
Loosen the 16 screws at the four corners of the crate, and then remove the iron plates.

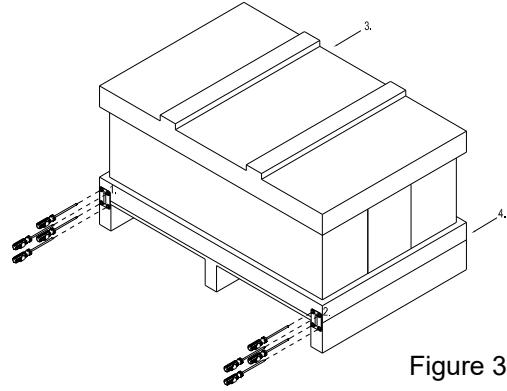

Figure 3-11

Take out the EPEs and the manual.

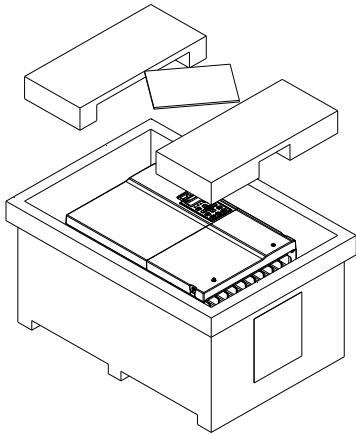

Figure 3-8

Remove the top cover, take out the EPEs, rubber and the manual.

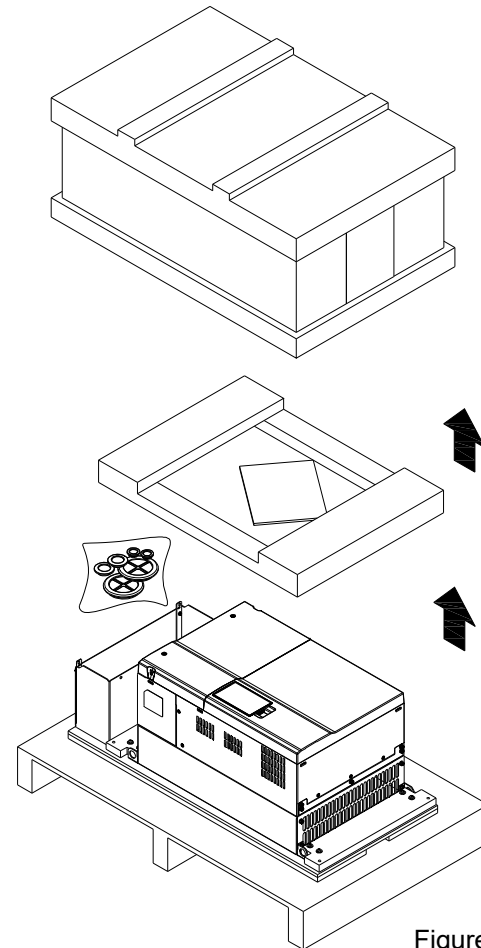

Figure 3-12

Loosen the eight screws fasten the drive on the pallet, and then remove the wood plate.

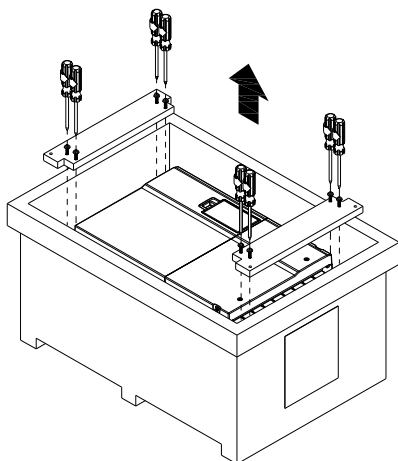

Figure 3-9

Lift the drive by hooking the lifting hole. It is now ready for installation.

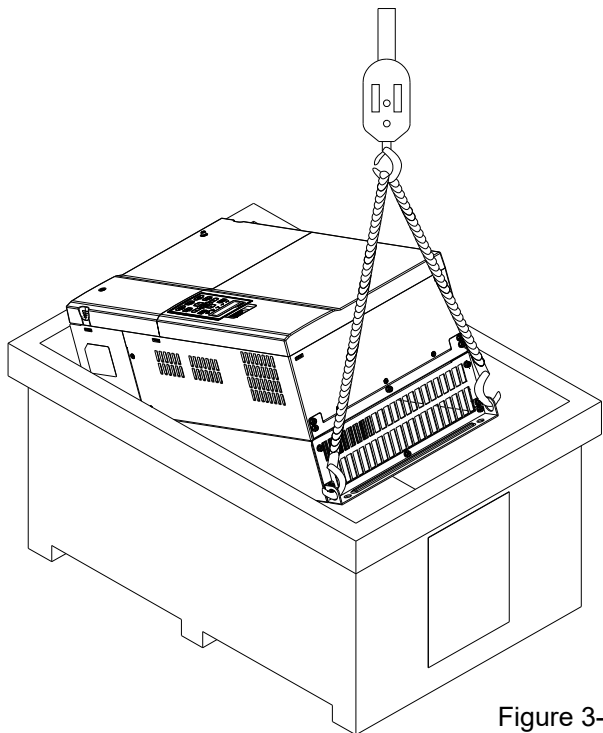

Figure 3-10

Loosen the ten screws fasten the drive on the pallet, and then remove the wood plate.

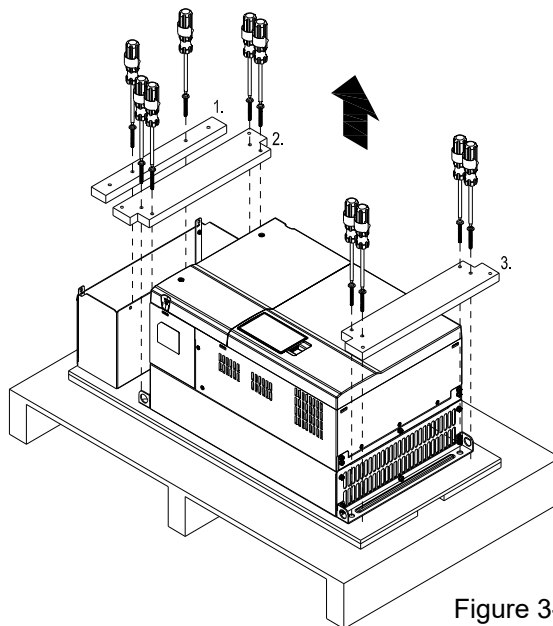

Figure 3-13

Lift the drive by hooking the lifting hole. It is now ready for installation.

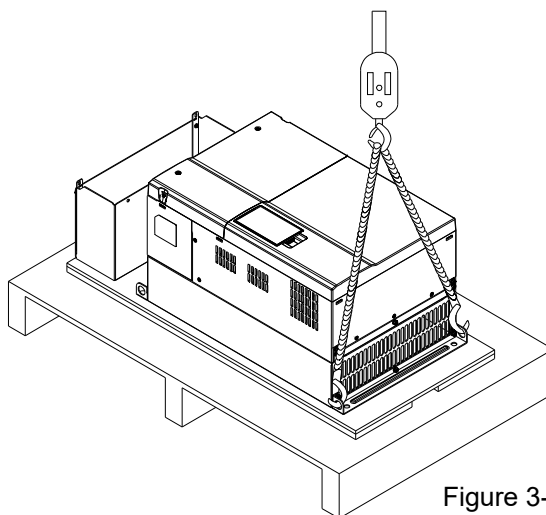

Figure 3-14

Frame E

Unpacking 1 (VFDXXXCXXA, VFDXXXC63B-00)  
Loosen the 16 screws at the four corners of the crate, and then remove the iron plates.

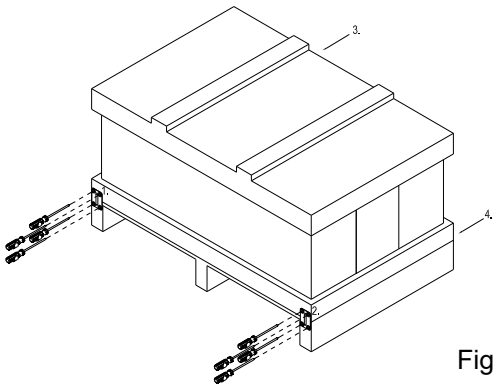

Figure 3-15

Unpacking 2 (VFDXXXCXXE, VFDXXXC63B-21)  
Loosen the 16 screws at the four corners of the crate, and then remove the iron plates.

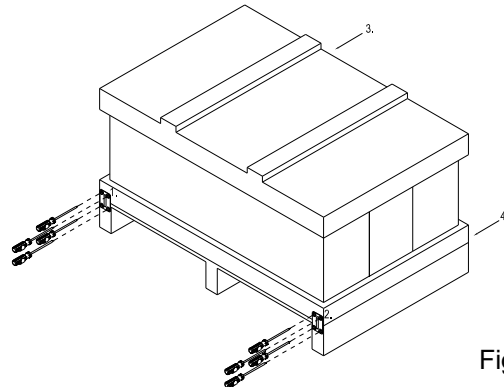

Figure 3-19

Remove the top cover, take out the EPEs and the manual.

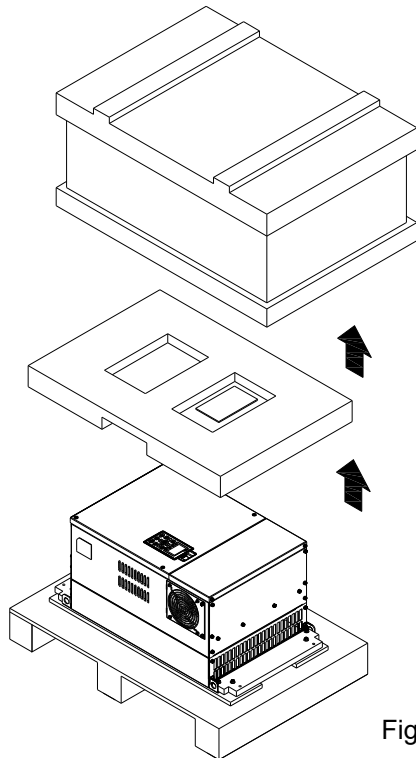

Figure 3-16

Remove the top cover, take out the EPEs, rubber and the manual.

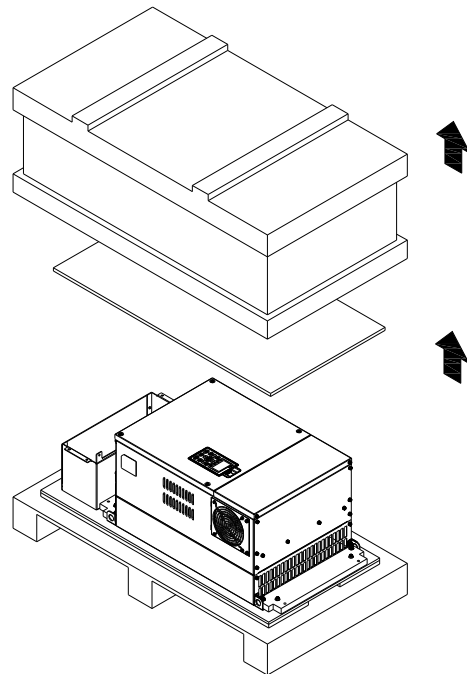

Figure 3-20

Loosen the eight screws fasten the drive on the pallet, and then remove the wood plate.

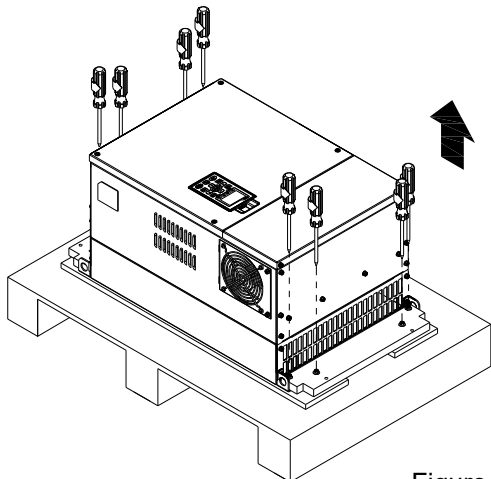

Figure 3-17

Loosen the ten screws fasten the drive on the pallet, and then remove the wood plates.

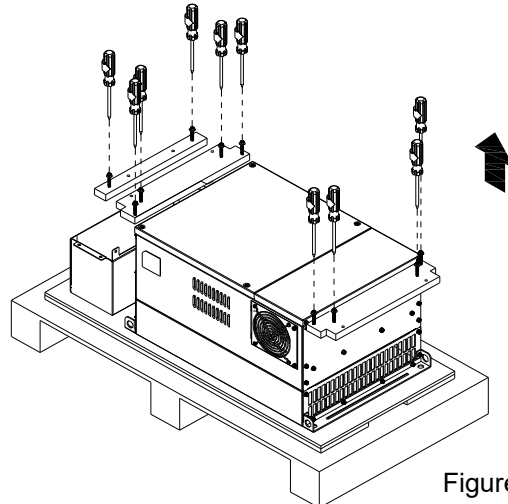

Figure 3-21

Lift the drive by hooking the lifting hole. It is now ready for installation.

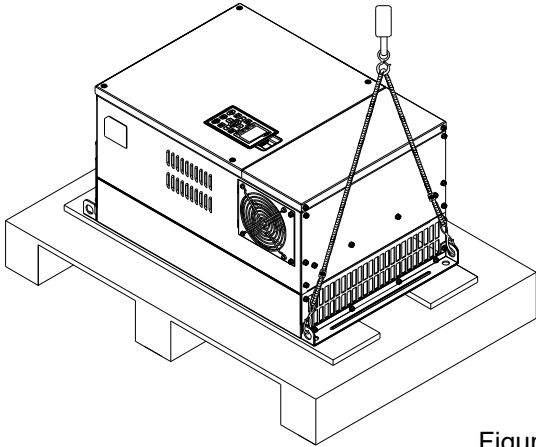

Figure 3-18

Lift the drive by hooking the lifting hole. It is now ready for installation.

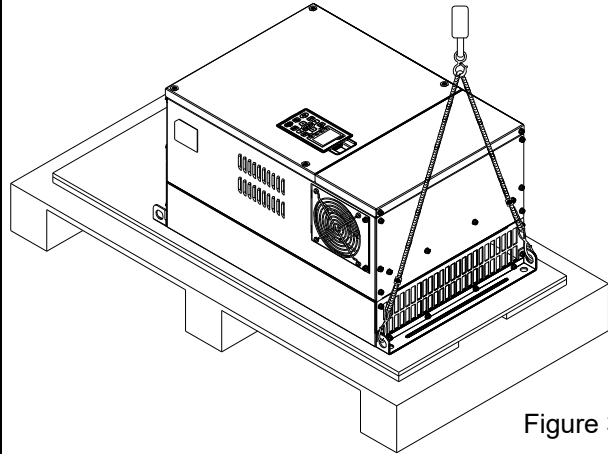

Figure 3-22

Frame F

**Unpacking 1 (VFDXXXCXXA, VFDXXXC63B-00)**  
 Remove the six buckles fixed on the crate with a flat-head screwdriver, see the figure below.

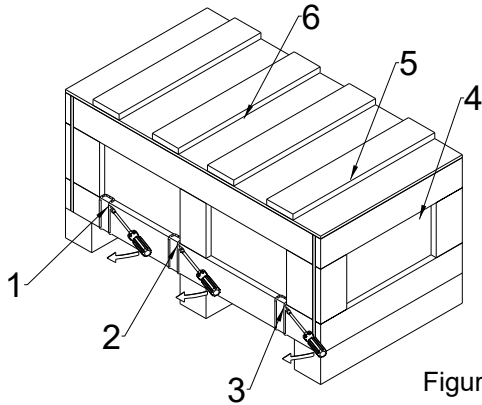

Figure 3-23

**Unpacking 2 (VFDXXXCXXE, VFDXXXC63B-21)**  
 Remove the six buckles fixed on the crate with a flat-head screwdriver, see the figure below.

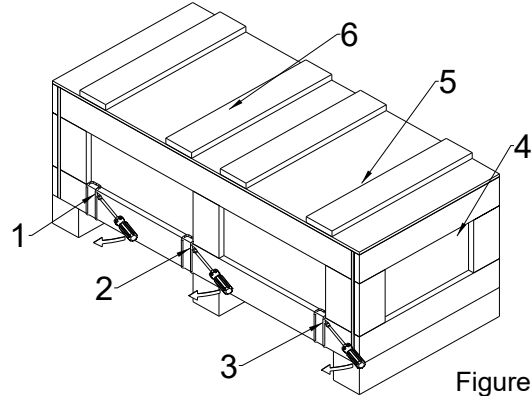

Figure 3-27

Remove the top cover, take out the EPEs and the manual.

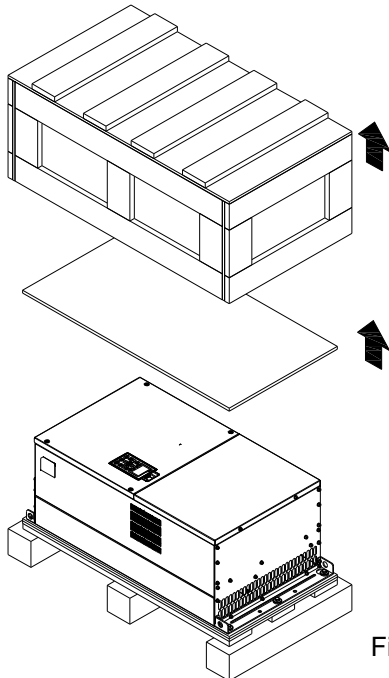

Figure 3-24

Remove the top cover, take out the EPEs, rubber and the manual.

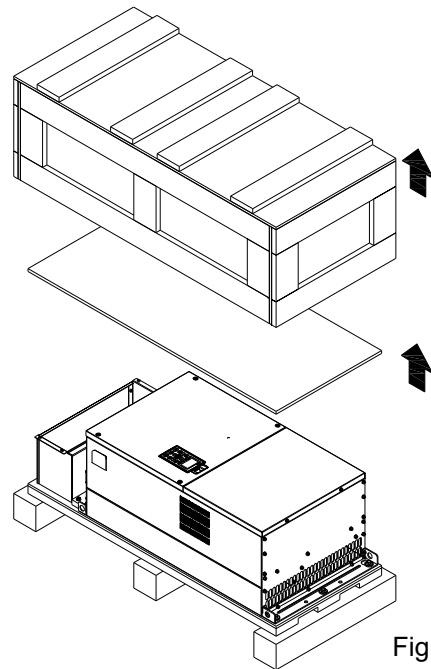

Figure 3-28

Loosen the five screws fasten the drive on the pallet, see the figure below.

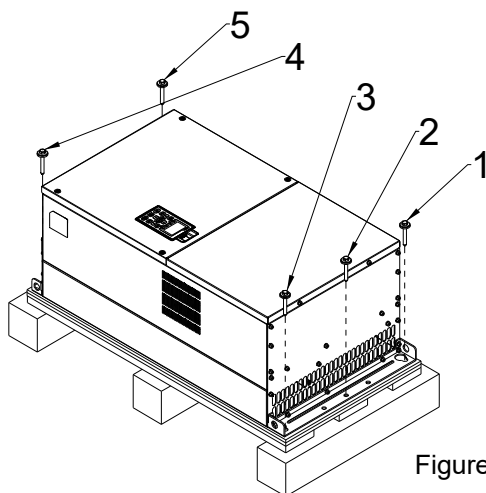

Figure 3-25

Loosen the five screws fasten the drive on the pallet, and then remove the wood plates.

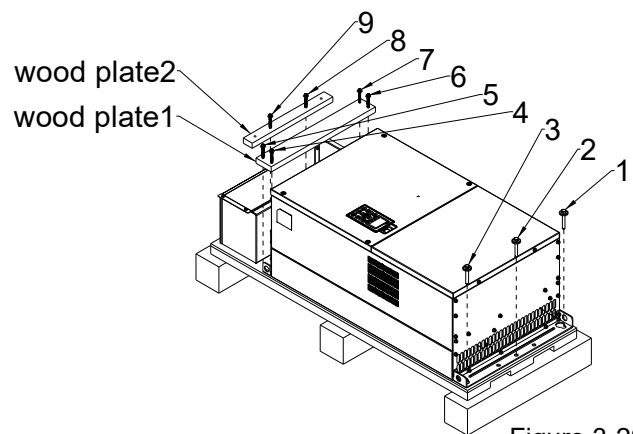

Figure 3-29

Lift the drive by hooking the lifting hole. It is now ready for installation

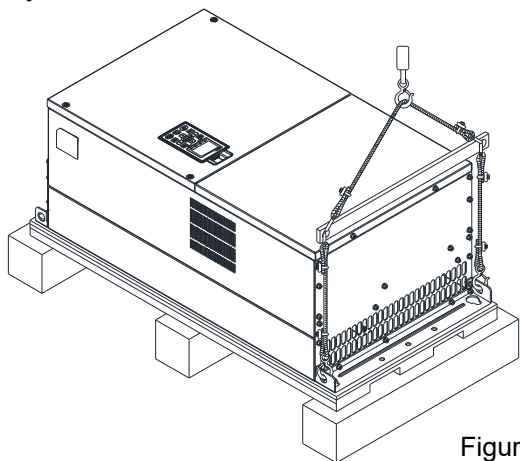

Figure 3-26

Lift the drive by hooking the lifting hole. It is now ready for installation.

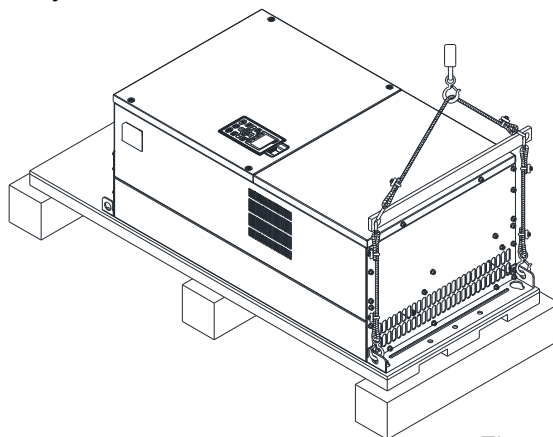

Figure 3-30

**Frame G**

**Unpacking 1 (VFDXXXCXXA, VFDXXXC63B-00)**

Remove the six buckles fixed on the crate with a flat-head screwdriver, see the figure below.

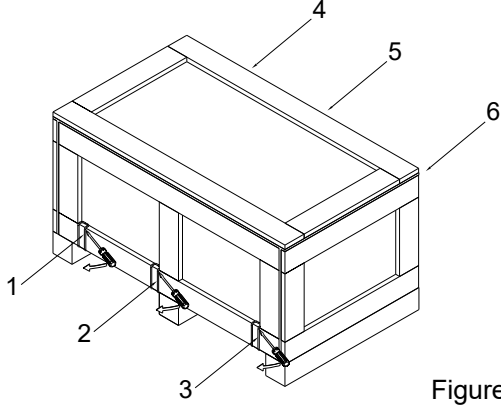

Figure 3-31

**Unpacking 2 (VFDXXXCXXE, VFDXXXC63B-21)**

Remove the six buckles fixed on the crate with a flat-head screwdriver, see the figure below.

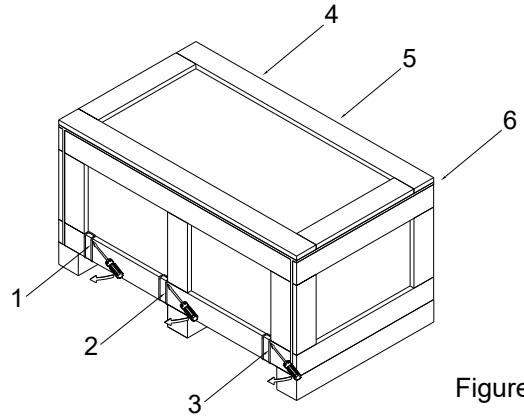

Figure 3-35

Remove the top cover, take out the EPEs and the manual.

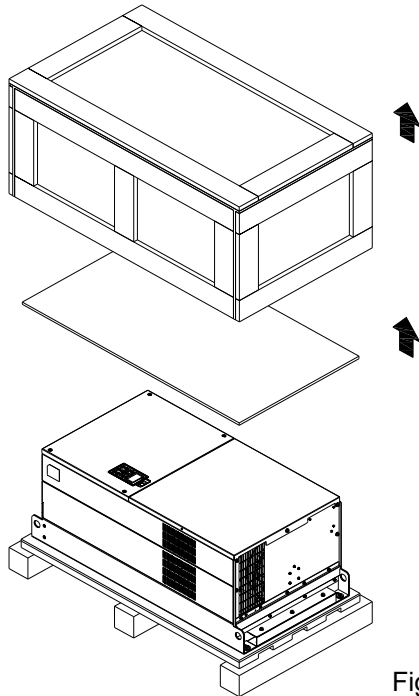

Figure 3-32

Remove the top cover, take out the EPEs, rubber and the manual.

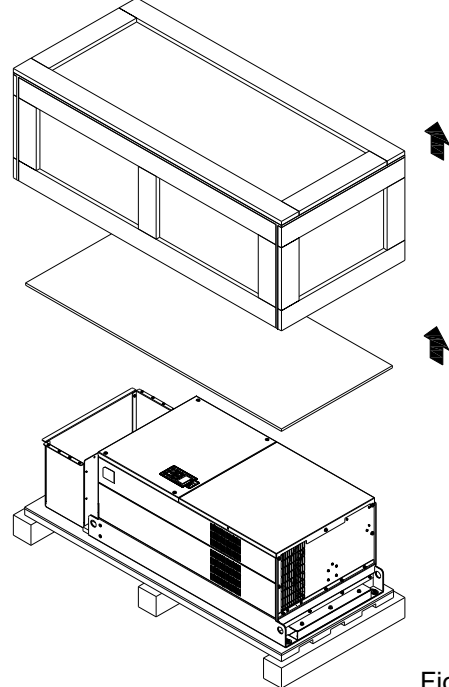

Figure 3-36

Loosen the five screws fasten the drive on the pallet, see the figure below.

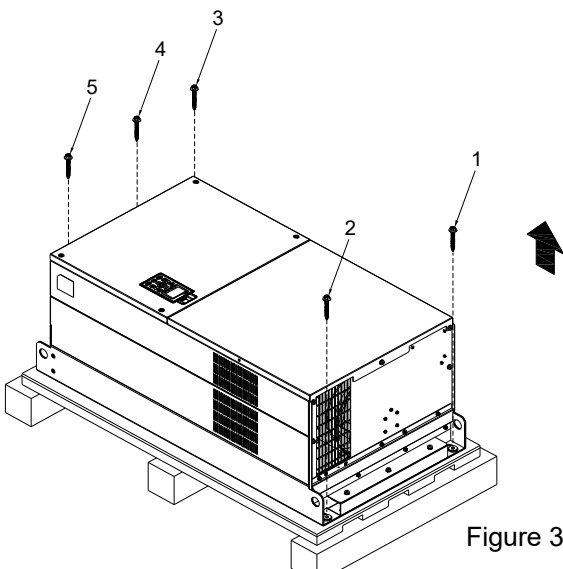

Figure 3-33

Loosen the 12 screws fasten the drive on the pallet, and then remove the wood plates.

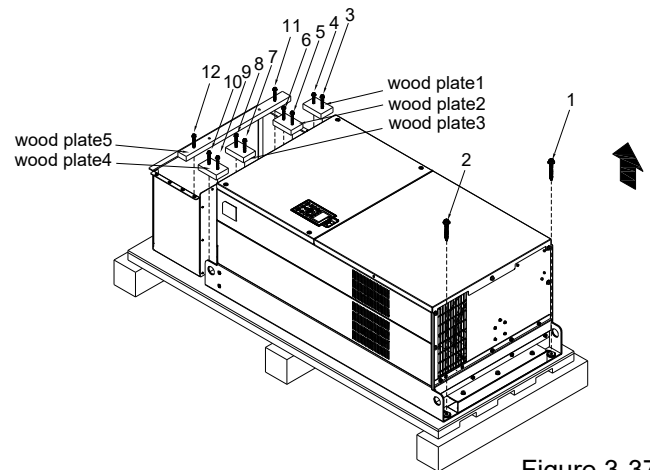

Figure 3-37

Lift the drive by hooking the lifting hole. It is now ready for installation.

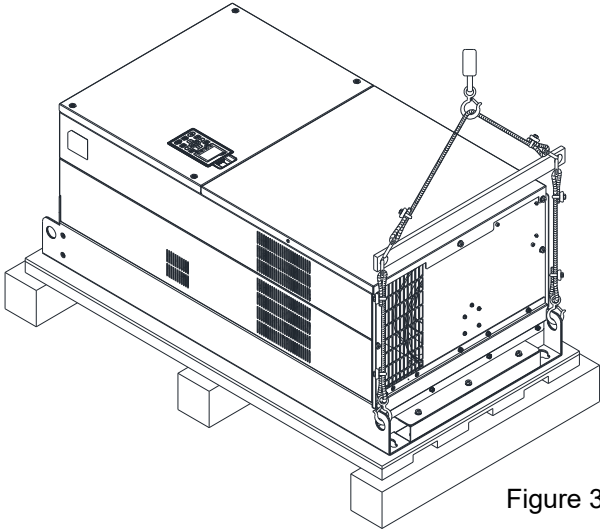

Figure 3-34

Lift the drive by hooking the lifting hole. It is now ready for installation.

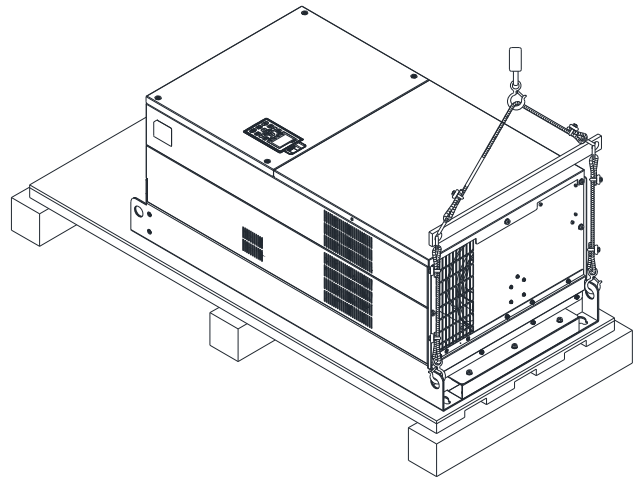

Figure 3-38



Frame H

Unpacking 1 (VFDXXXC43A)

Remove the eight buckles fixed on the crate with a flat-head screwdriver, see the figure below.

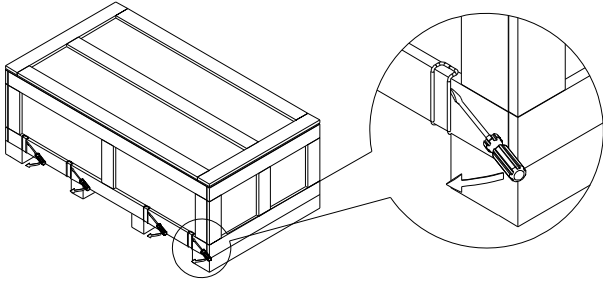

Figure 3-39

Unpacking 2 (VFDXXXC43E-1)

Remove the eight buckles fixed on the crate with a flat-head screwdriver, see the figure below.

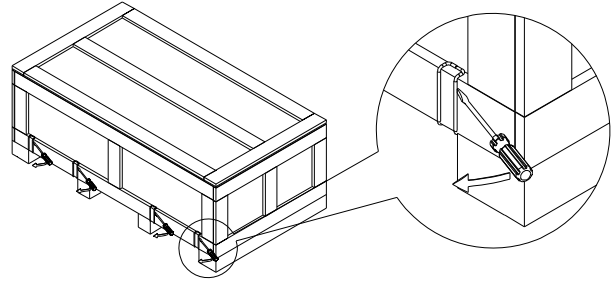

Figure 3-43

Remove the top cover, take out the EPEs and the manual.

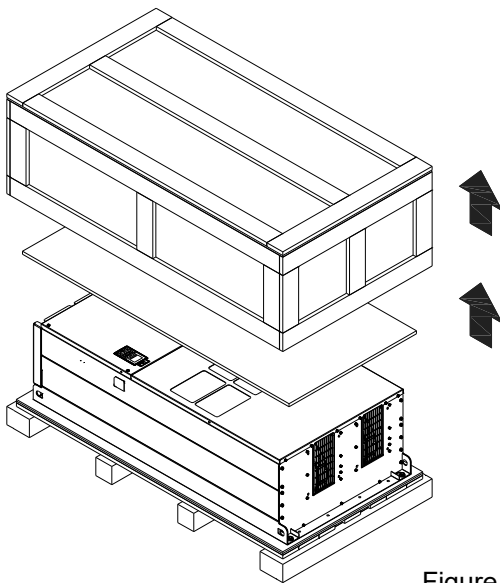

Figure 3-40

Remove the top cover, take out the EPEs, rubber and the manual.

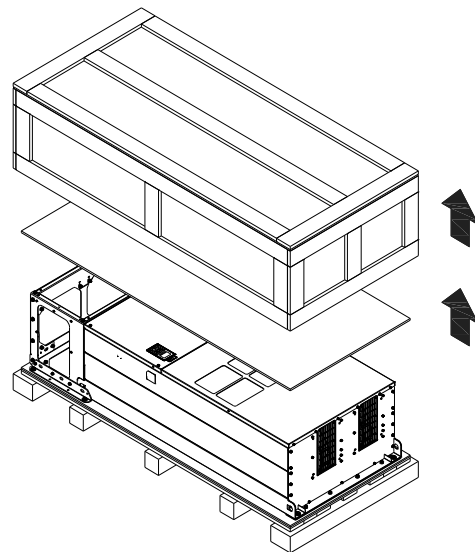

Figure 3-44

Loosen the six screws fasten the drive on the pallet, and then remove six metal washers and six plastic washers. See the figure below.

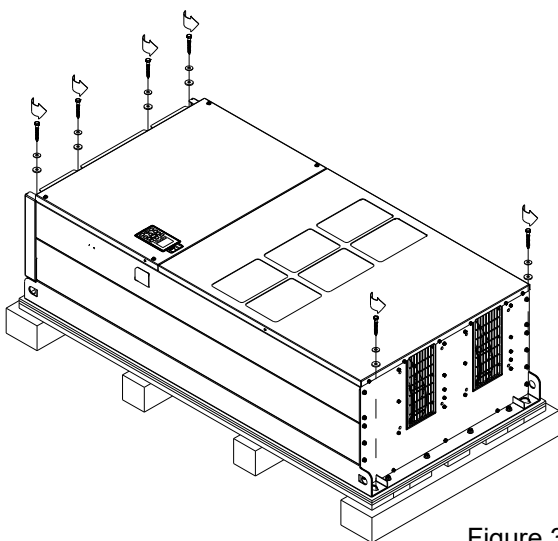

Figure 3-41

Loosen the six screws fasten the drive on the pallet, and then remove six metal washers and six plastic washers. See the figure below.

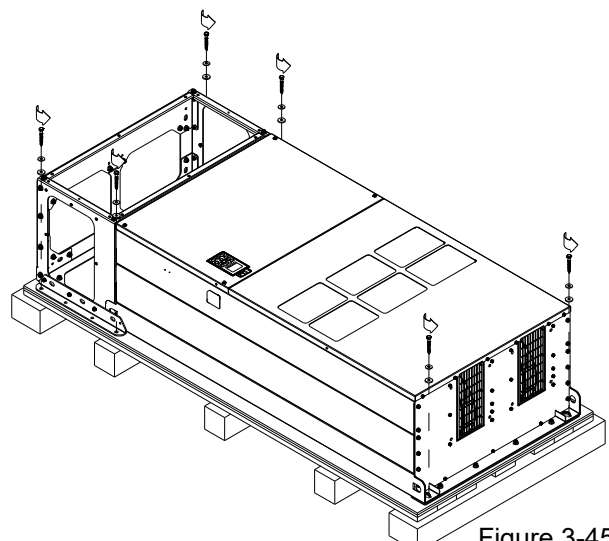

Figure 3-45

Lift the drive by hooking the lifting hole. It is now ready for installation.

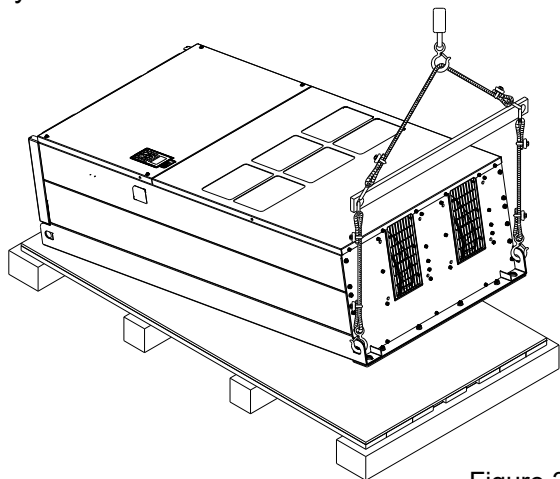

Figure 3-42

Loosen the six M6 screws and the iron plates (see the figure below). You can use the removed screws and iron plates to fix the drive from outside.

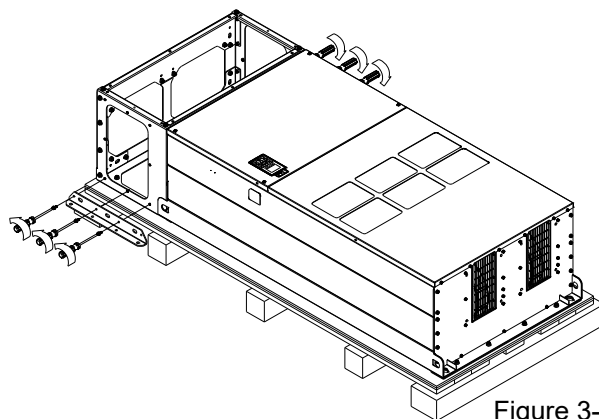

Figure 3-46

This description is how to fix the drive from the outside. You can skip to the next step if it's not necessary.

Loosen the eight M8 screws, and then use these eight M8 screws to fix the iron plates (removed at the last step) to the drive, see the figure below.

Torque: 150–180 kg-cm / [130.20–156.24 lb-in.] / [14.7–17.6 Nm]

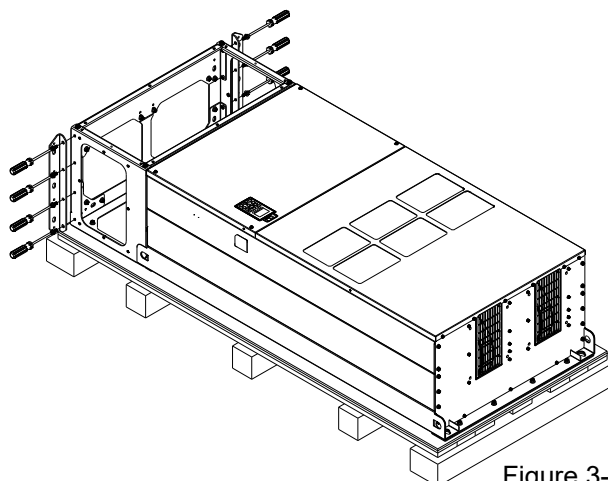

Figure 3-47

Lift the drive by hooking the lifting hole. It is now ready for installation.

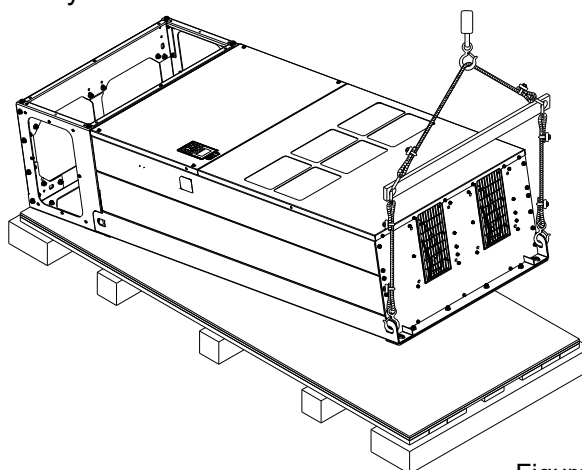

Figure 3-48

Frame H

Unpacking 3 (VFDXXXC43E)

Remove the eight buckles fixed on the crate with a flat-head screwdriver, see the figure below.

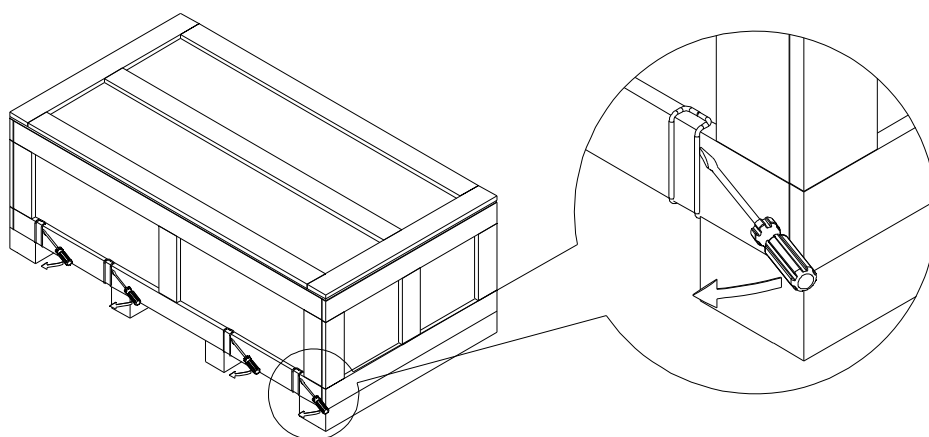

Figure 3-49

Remove the top cover, take out the EPEs, rubber and the manual.

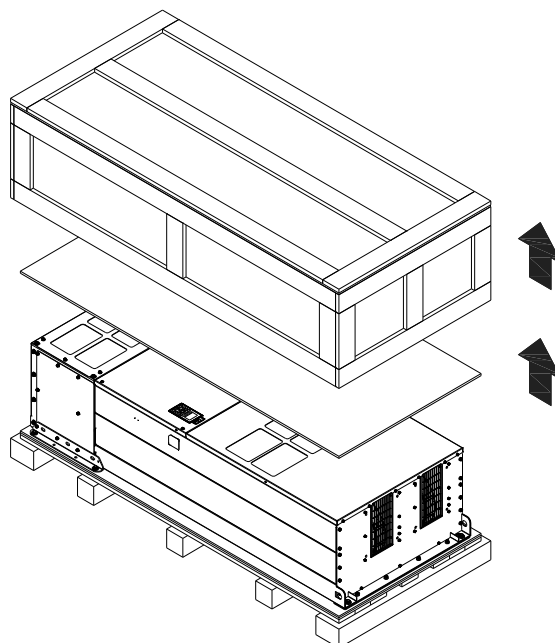

Figure 3-50

Loosen the six screws fasten the drive on the pallet, and then remove six metal washers and six plastic washers. See the figure below.

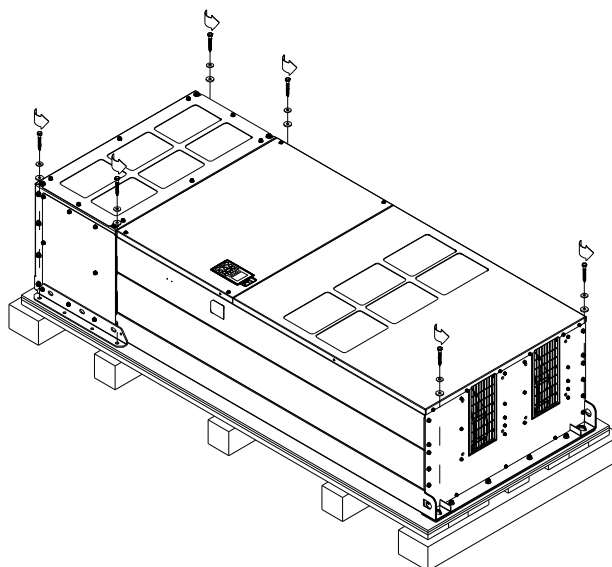

Figure 3-51

Loosen the six M6 screws and the iron plates (see the figure below). You can use the removed screws and iron plates to fix the drive from the outside.

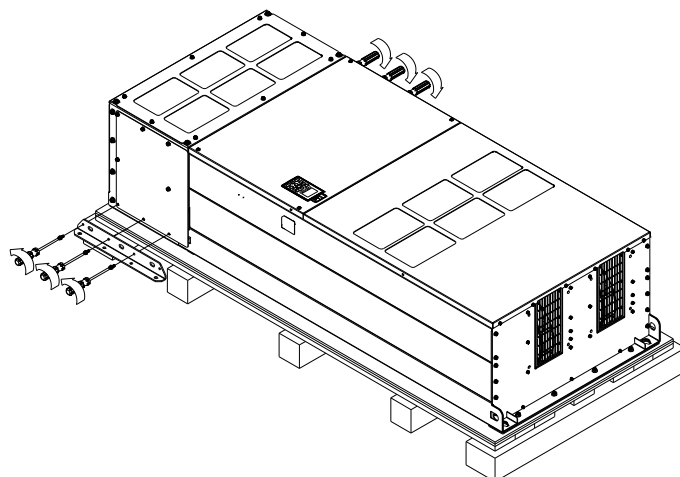

Figure 3-52

**Fix the drive from the inside**

Loosen the 18 M6 screws and remove the covers (see the figure 3-54). After fixing the drive and the cover for cables (see the figure 3-53), fasten the other covers back (see the figure 3-54)

Torque: 35–45 kg-cm / [30.38–39.06 lb-in.] / [3.4–4.4 Nm]

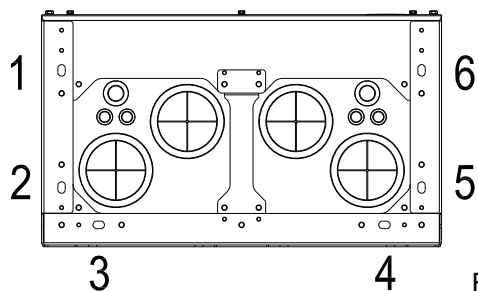

Figure 3-53

Cover for cables (use M12 screws)

**Fix the drive from the outside**

Loosen the eight M8 screws, and then use these eight M8 screws to fix the iron plates (removed at the last step) to the drive, see the figure below.

Torque: 150–180 kg-cm / [130.20–156.24 lb-in.] / [14.7–17.6 Nm]

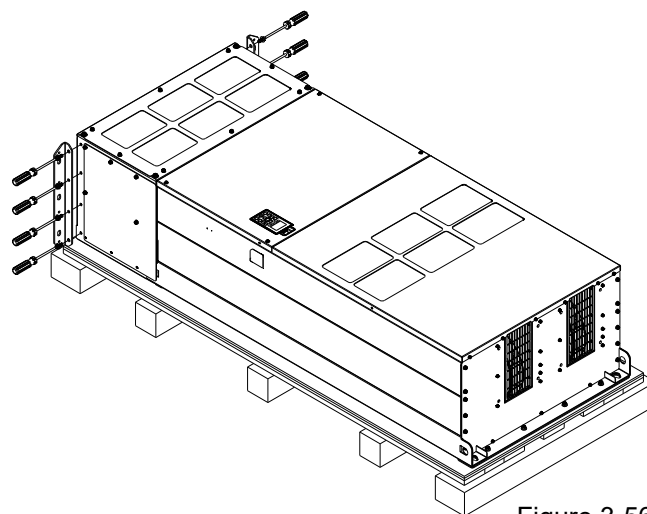

Figure 3-56

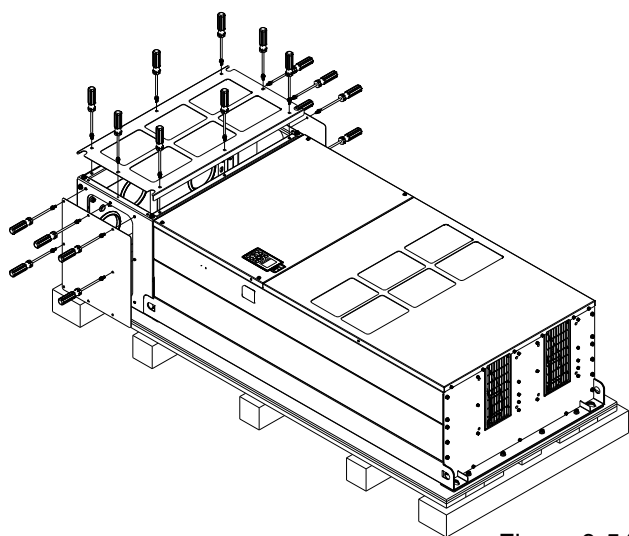

Figure 3-54

Fasten the six M6 screws back, see the figure below.

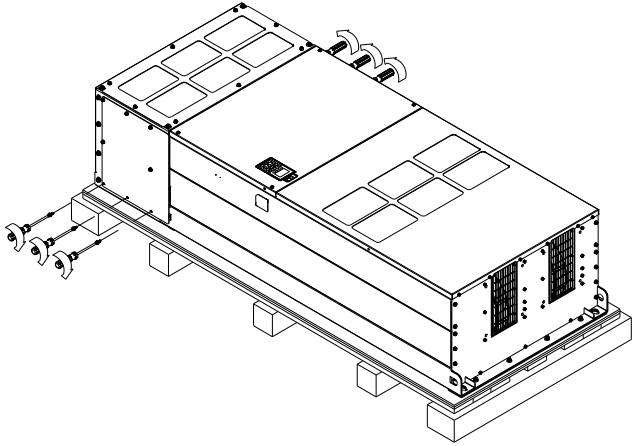

Figure 3-55

Fasten the six M6 screws back, see the figure below.

Torque: 35–45 kg-cm / [30.8–39.06 lb-in] / [3.4–4.4 Nm]

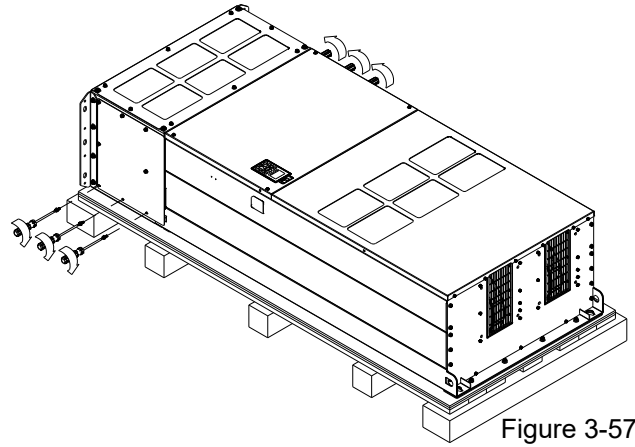

Figure 3-57

Lift the drive by hooking the lifting hole. It is now ready for installation.

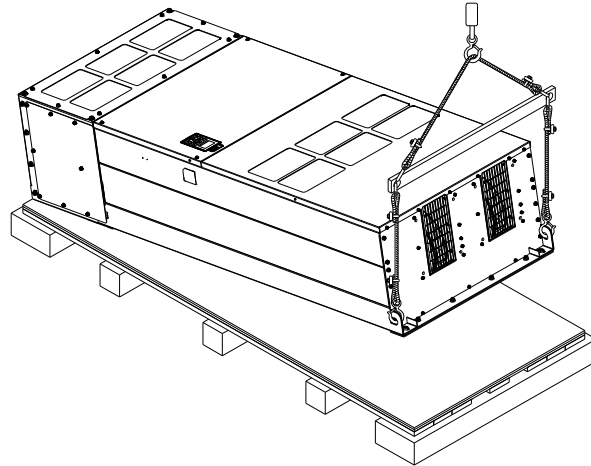

Figure 3-58

690V Frame H

Unpacking 1 (VFDXXXC63B-00)

Remove the eight buckles fixed on the crate with a flat-head screwdriver, see the figure below.

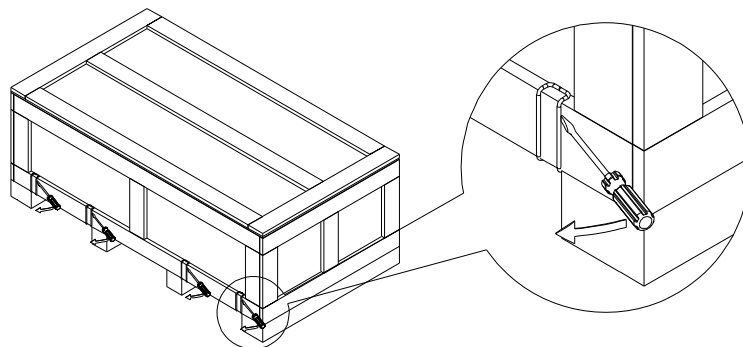

Figure 3-59

Remove the top cover, take out the EPEs and the manual.

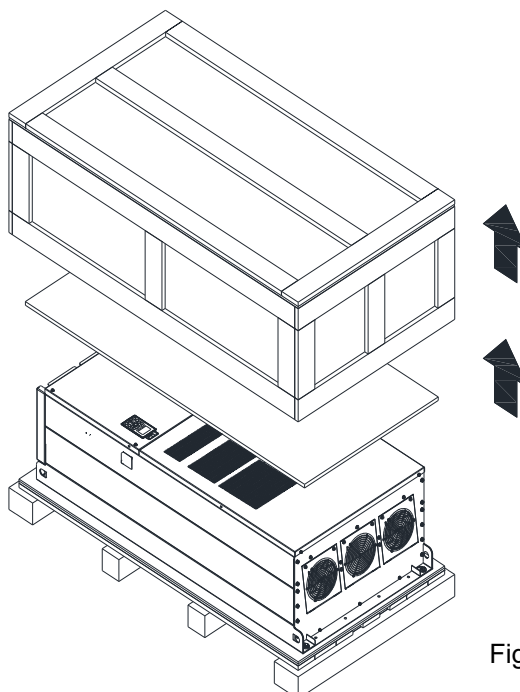

Figure 3-60

Loosen the six screws fasten the drive on the pallet, and then remove six metal washers and six plastic washers. See the figure below.

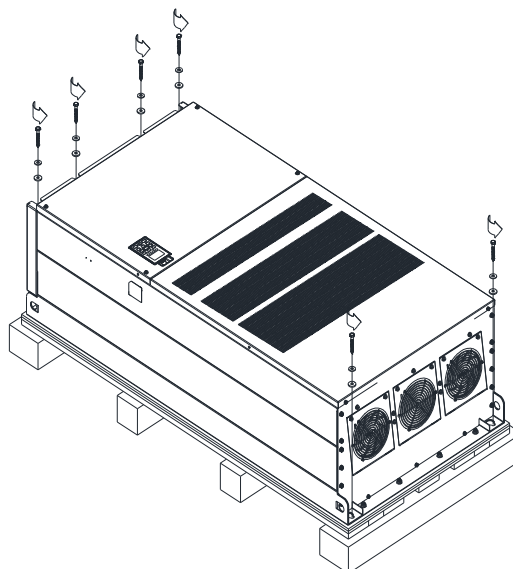

Figure 3-61

Lift the drive by hooking the lifting hole. It is now ready for installation.

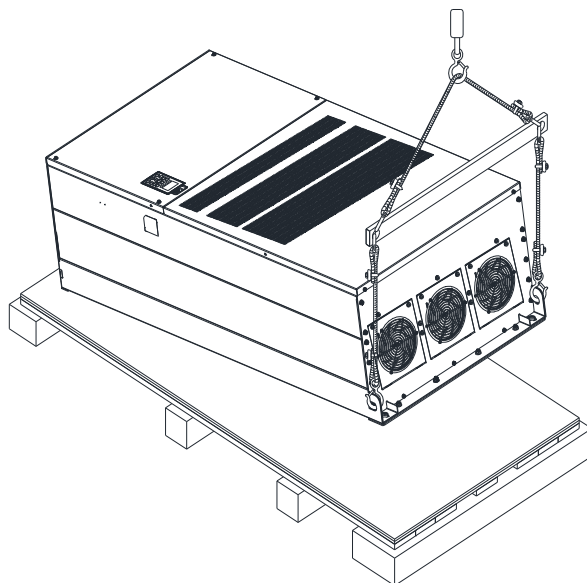

Figure 3-62

690V Frame H

Unpacking 2 (VFDXXXC63B-21)

Remove the eight buckles fixed on the crate with a flat-head screwdriver, see the figure below.

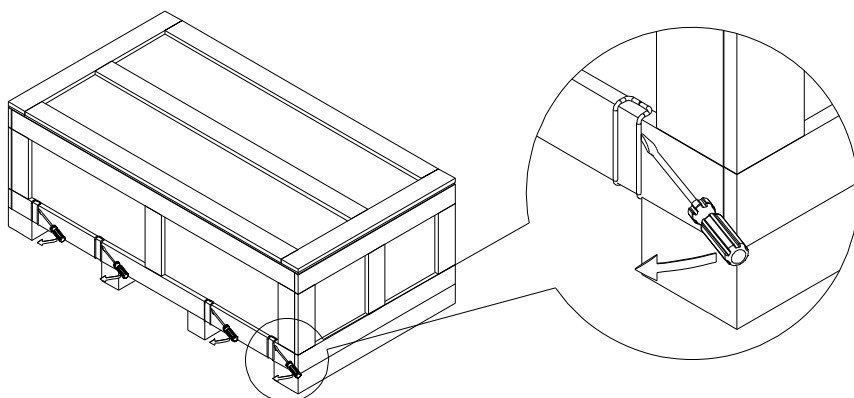

Figure 3-63

Remove the top cover, take out the EPEs, rubber and the manual.

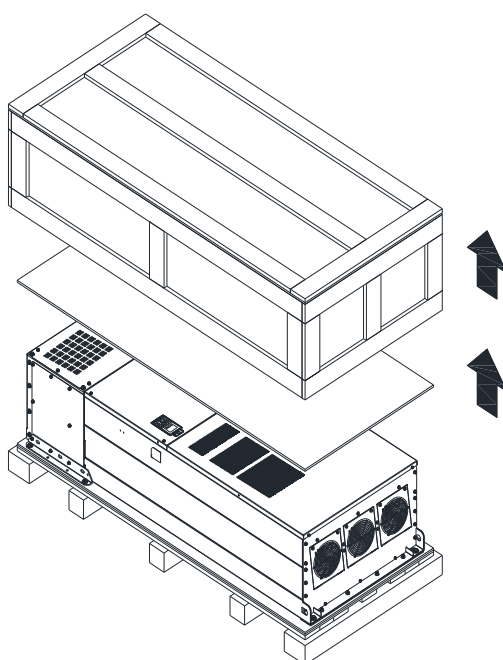

Figure 3-64

Loosen the six screws fasten the drive on the pallet, and then remove six metal washers and six plastic washers. See the figure below.

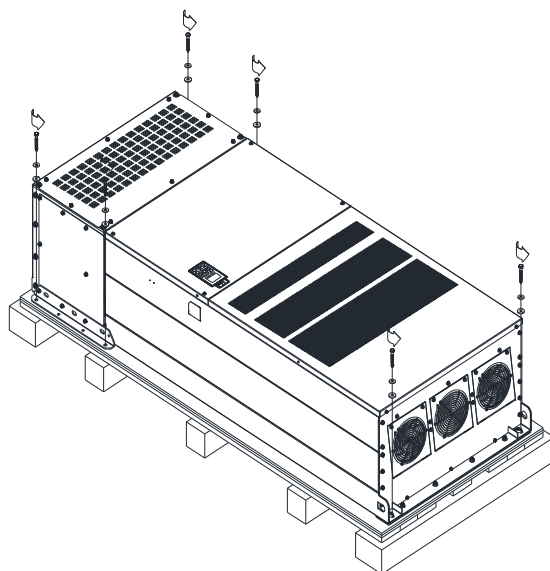

Figure 3-65



Loosen the six M6 screws and the iron plates (see the figure below). You can use the removed screws and iron plates to fix the drive from the outside.

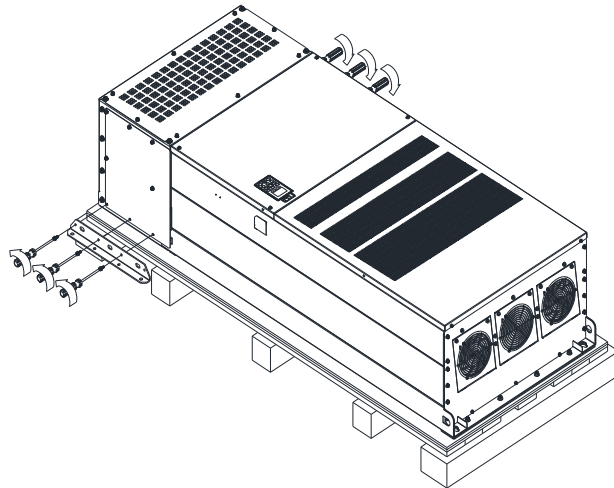
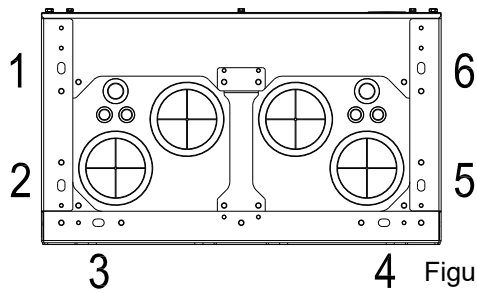

Figure 3-66

**Fix the drive from the inside.**

Loosen the 18 M6 screws and remove the covers (see the figure 3-68). After fixing the drive and the cover for cables (see the figure 3-67), fasten the other covers back (see the figure 3-68)

Torque: 35–45 kg-cm / [30.38–39.06 lb-in.] / [3.4–4.4 Nm]



Cover for cables (use M12 screws)

**Fix the drive from the outside.**

Loosen the eight M8 screws, and then use these eight M8 screws to fix the iron plates (removed at the last step) to the drive, see the figure below.

Torque: 150–180 kg-cm / [130.20–156.24 lb-in.] / [14.7–17.6 Nm]

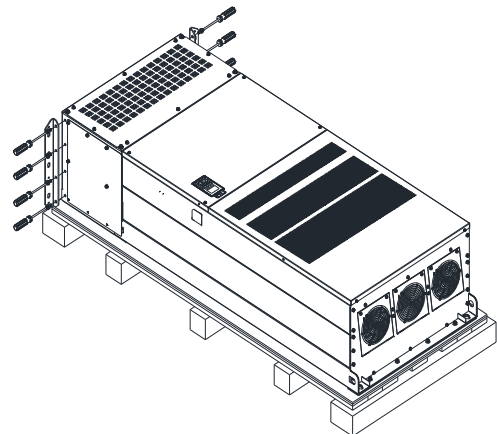

Figure 3-70

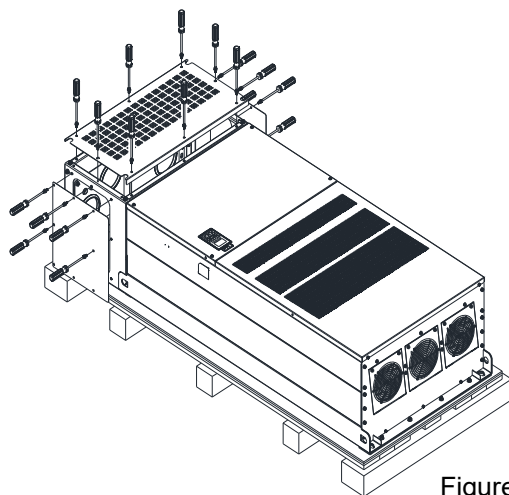

Figure 3-68

Fasten the six M6 screws back, see the figure below.

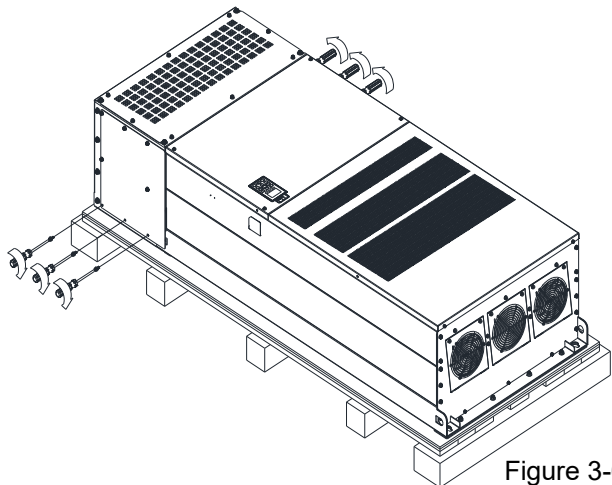

Figure 3-69

Fasten the six M6 screws back, see the figure below.

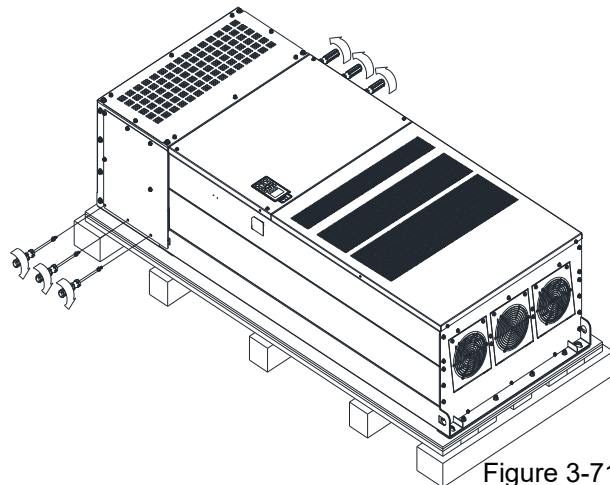

Figure 3-71

Lift the drive by hooking the lifting hole. It is now ready for installation.

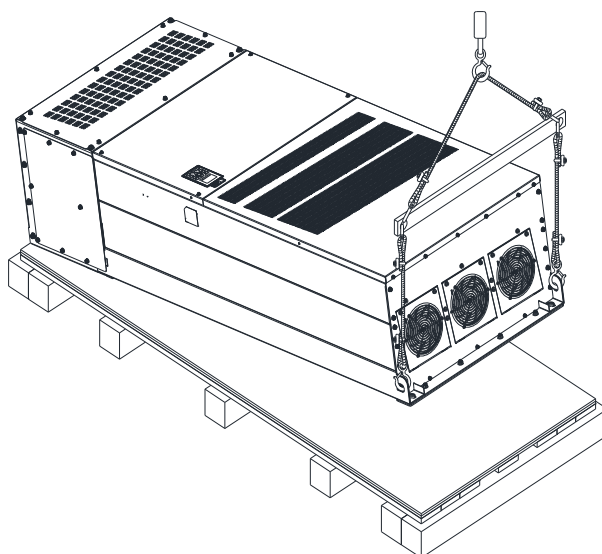

Figure 3-72

Frame H: Fix the drive

VFDXXXC43A

Screw: M12\*6

Torque: 340–420 kg-cm / [295.1–364.6 lb-in.] / [33.3–41.2 Nm]

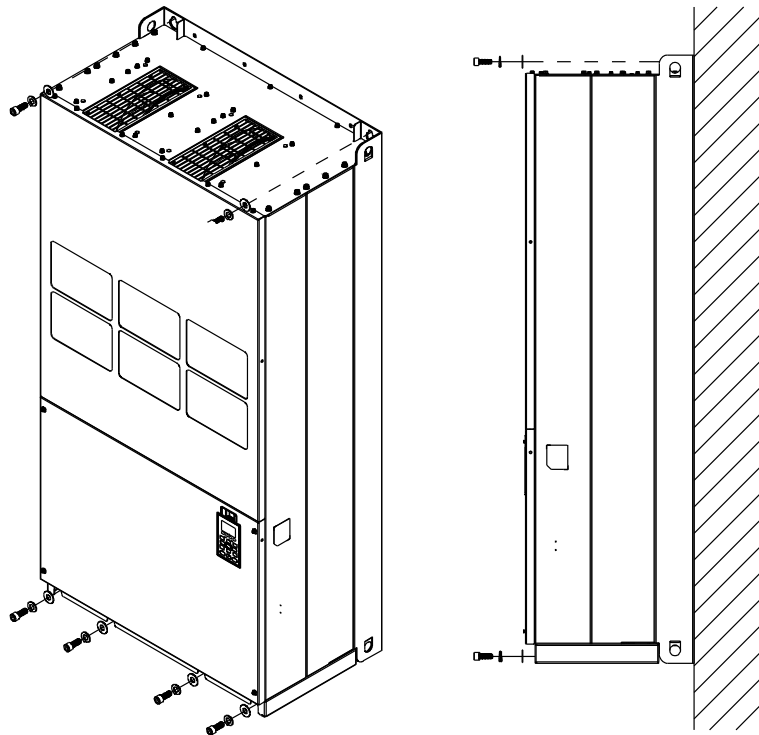
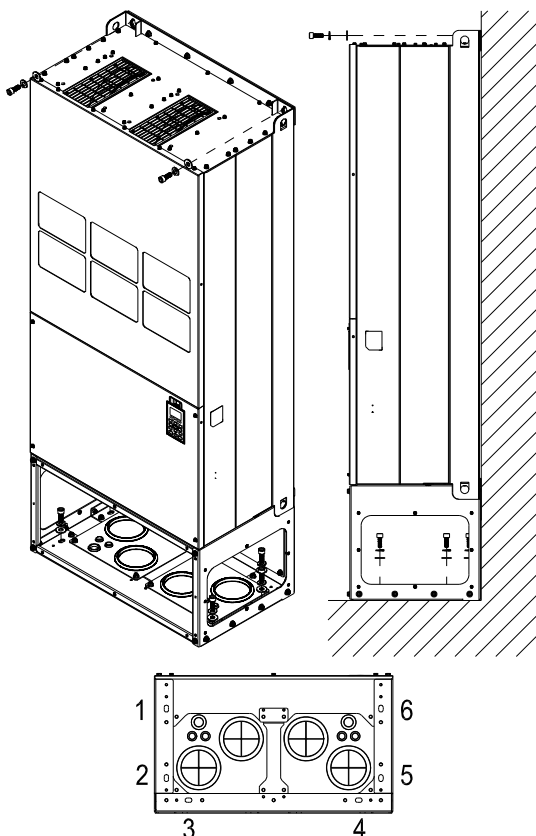

Figure 3-73

VFDXXXC43E & VFDXXXC43E-1



Fix the drive from the inside.

Screw: M12\*8

Torque: 340–420 kg-cm / [295.1–364.6 lb-in.] /  
[33.3–41.2 Nm]

Figure 3-74

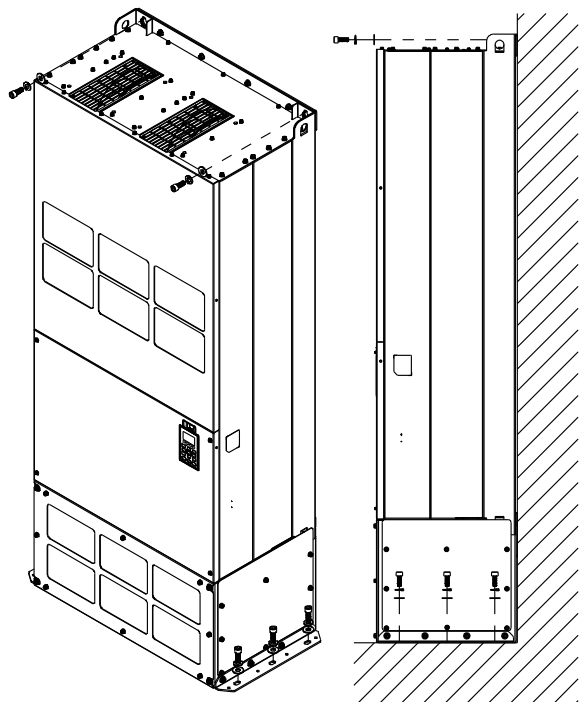

Fix the drive from the outside.

Screw: M12\*8

Torque: 340–420 kg-cm / [295.1–364.6 lb-in.] /  
[33.3–41.2 Nm]

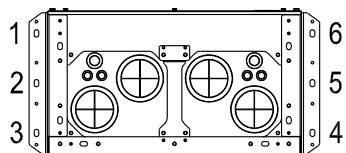

Figure 3-75

VFDXXXC63B

Screw M 12\*6

Torque: 340–420 kg-cm / [295.1–364.6 lb-in.] / [33.32–41.16 Nm]

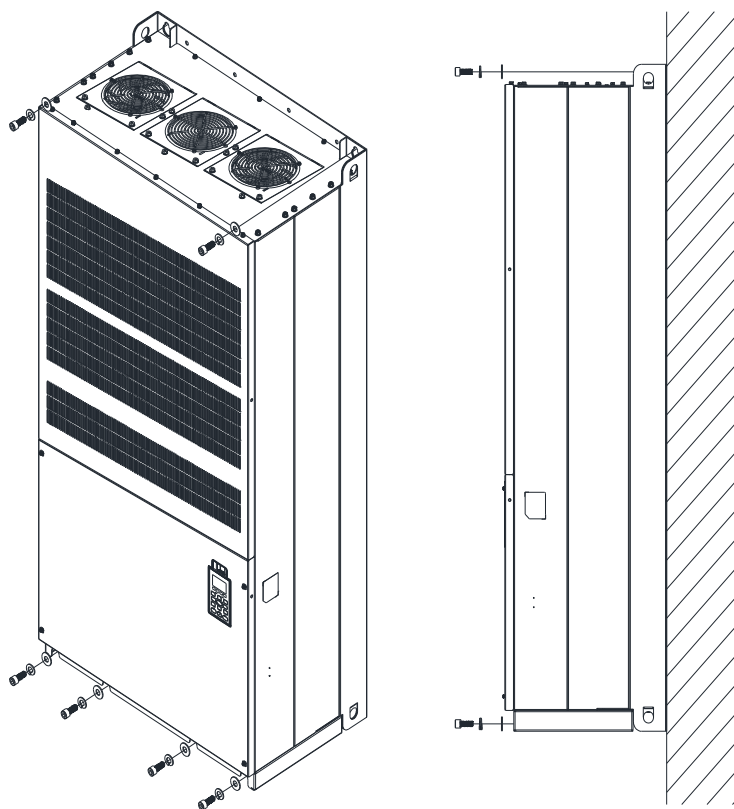
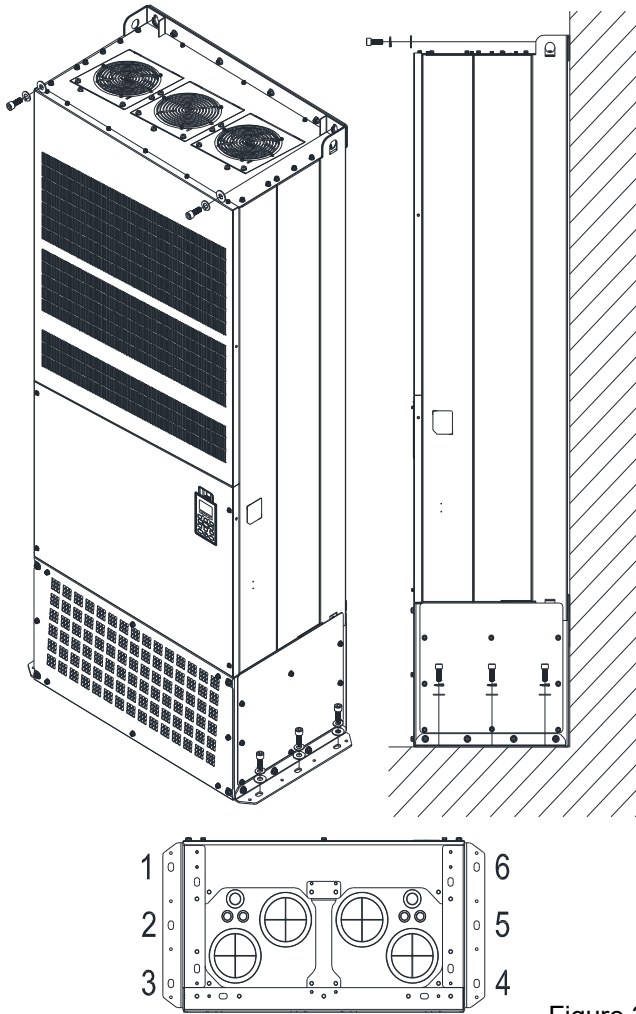

Figure 3-76



Fix the drive from the outside.  
Screw: M12\*8  
Torque: 340–420 kg-cm / [295.1–364.6 lb-in.] /  
[33.32–41.16 Nm]

Figure 3-77

### 3-2 The Lifting Hook

The arrows indicate the location of the lifting holes of frame D to H, as shown in figure below:

**Frame D0**

Applicable models:

VFD370C43S; VFD450C43S; VFD370C43U;

VFD450C43U

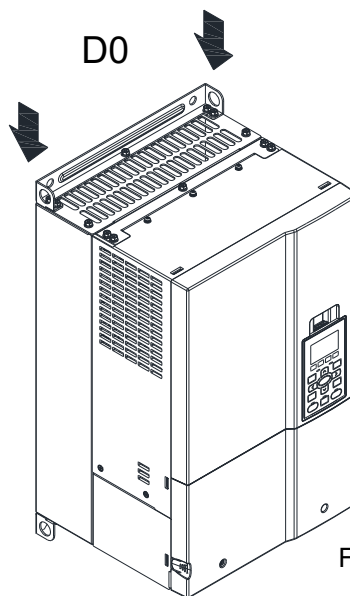

Figure 3-78

**Frame D**

Applicable models:

VFD300C23A; VFD370C23A; VFD550C43A;

VFD300C23E; VFD370C23E; VFD550C43E;

VFD750C43E; VFD450C63B-00; VFD550C63B-00;

VFD450C63B-21; VFD550C63B-21

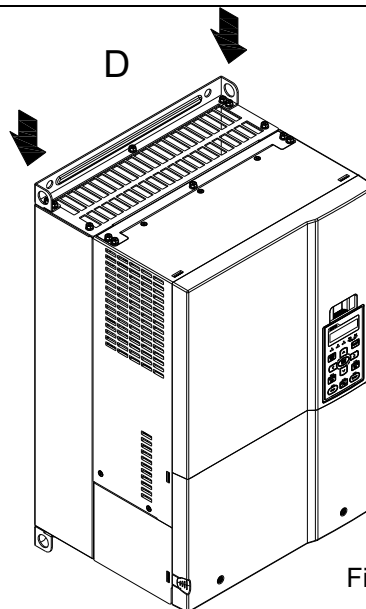

Figure 3-79

**Frame E**

Applicable models:

VFD450C23A; VFD550C23A; VFD750C23A;

VFD900C43A; VFD1100C43A; VFD450C23E;

VFD550C23E; VFD750C23E; VFD900C43E;

VFD1100C43E; VFD750C63B-00; VFD900C63B-00;

VFD1100C63B-00; VFD1320C63B-00; VFD750C63B-21;

VFD900C63B-21; VFD1100C63B-21; VFD1320C63B-21

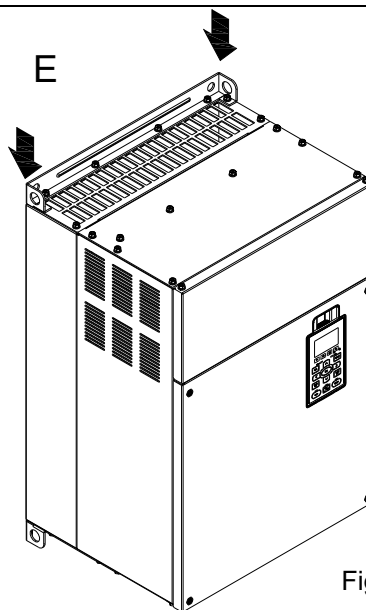

Figure 3-80

**Frame F**

Applicable models:

VFD900C23A; VFD1320C43A; VFD1600C43A;  
 VFD900C23E; VFD1320C43E; VFD1600C43E;  
 VFD1600C63B-00; VFD2000C63B-00;  
 VFD1600C63B-21; VFD2000C63B-21

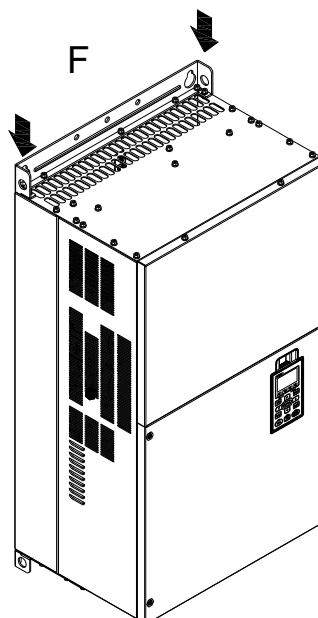

Figure 3-81

**Frame G**

Applicable models:

VFD1850C43A; VFD2200C43A; VFD1850C43E;  
 VFD2200C43E; VFD2500C63B-00; VFD3150C63B-00;  
 VFD2500C63B-21; VFD3150C63B-21

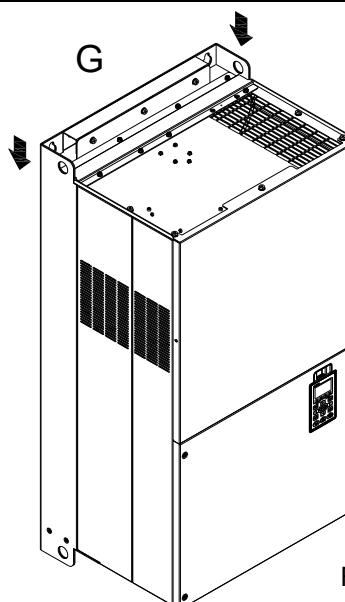

Figure 3-82

**Frame H**

Applicable models:

VFD2800C43A; VFD3150C43A; VFD3550C43A;  
 VFD4500C43A; VFD2800C43E-1; VFD3150C43E-1;  
 VFD3550C43E-1; VFD4500C43E-1; VFD2800C43E;  
 VFD3150C43E; VFD3550C43E; VFD4500C43E;  
 VFD4000C63B-00; VFD4500C63B-00;  
 VFD5600C63B-00; VFD6300C63B-00

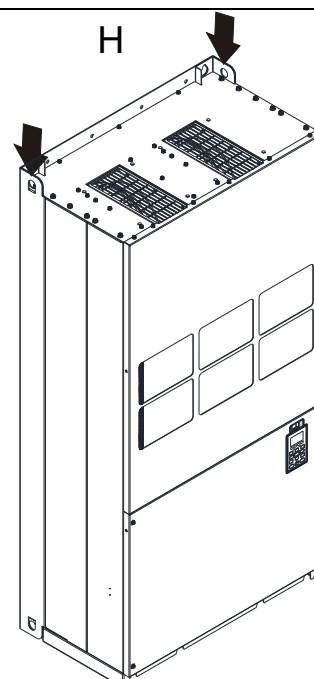

Figure 3-83

690V Frame H3

Applicable models:

VFD4000C63B-21; VFD4500C63B-21;

VFD5600C63B-21; VFD6300C63B-21

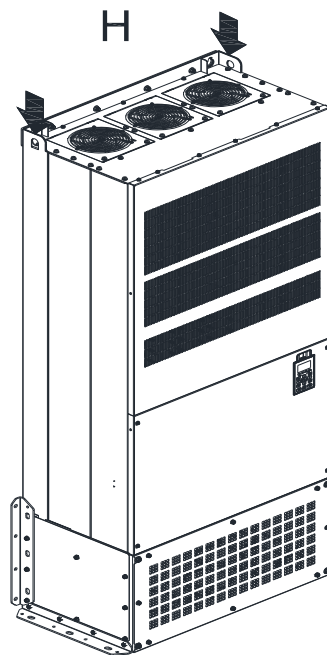

Figure 3-84



Ensure the lifting hook properly goes through the lifting hole, as shown in the following diagram.

Applicable to Frame D0–E

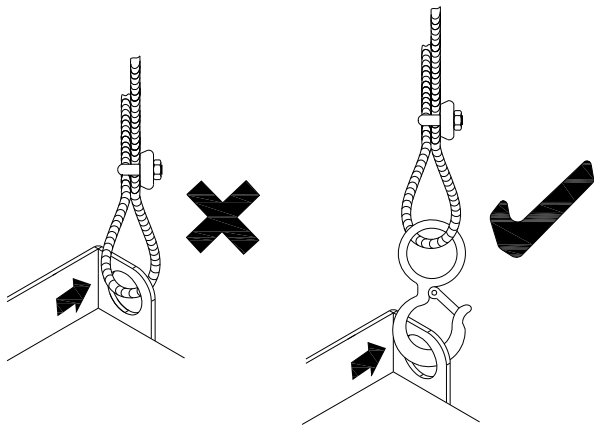

Figure 3-85

Applicable to Frame F–H

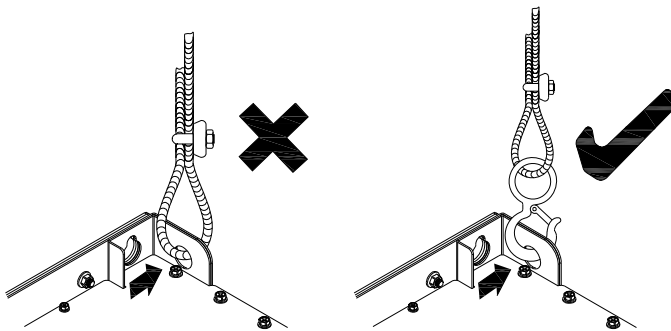

Figure 3-86

Ensure the angle between the lifting holes and the lifting device is within the specification, as shown in the following figure.

Applicable to Frame D0–E

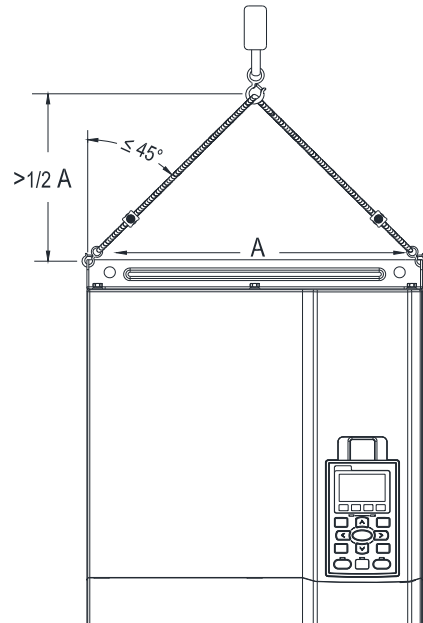

Figure 3-87

Applicable to Frame F–H, 690V Frame H3

Following drawing is only for demonstration, it may be slightly different with the machine you have.

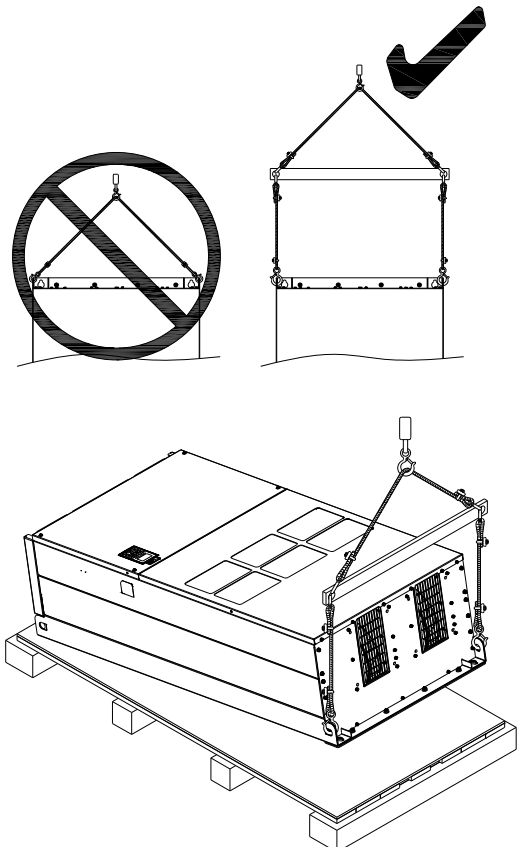

Figure 3-88

Weight

D0

VFDXXXXCXXA: 27kg / [59.5 lbs]

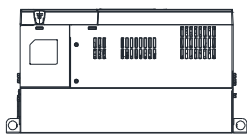

Figure 3-89

VFDXXXXCXXE: 29kg / [63.9 lbs]

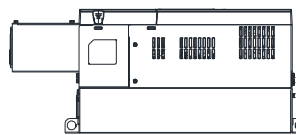

Figure 3-90

D

VFDXXXXCXXA: 37.6kg / [82.9 lbs]  
VFDXXXC63B-00: 39.0kg / [86.0 lbs]

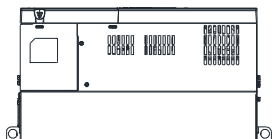

Figure 3-91

VFDXXXXCXXE: 40kg / [88.2 lbs]  
VFDXXXC63B-21: 41.1kg / [91.3 lbs]

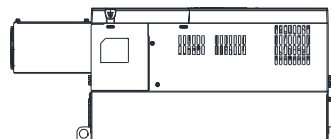

Figure 3-92

E

VFDXXXXCXXA: 63.6kg / [140.2 lbs]  
VFDXXXC63B-00: 61.0kg / [134.5 lbs]

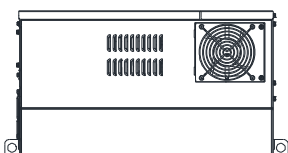

Figure 3-93

VFDXXXXCXXE: 66kg / [145.5 lbs]  
VFDXXXC63B-21: 63.4kg / [139.8 lbs]

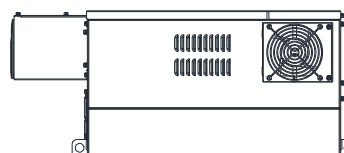

Figure 3-94

F

VFDXXXXCXXA: 85kg / [187.2 lbs]  
VFDXXXC63B-00: 88.0kg / [194.0 lbs]

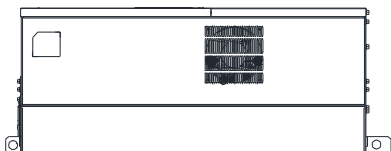

Figure 3-95

VFDXXXXCXXE: 88kg / [193.8 lbs]  
VFDXXXC63B-21: 91.0kg / [200.7 lbs]



Figure 3-96

G

VFDXXXXCXXA: 130kg / [286.5 lbs]  
VFDXXXC63B-00: 135.0kg / [297.6 lbs]

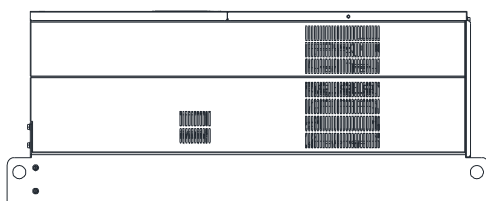

Figure 3-97

VFDXXXXCXXE: 138kg / [303.9 lbs]  
VFDXXXC63B-21: 143.0kg / [315.3 lbs]

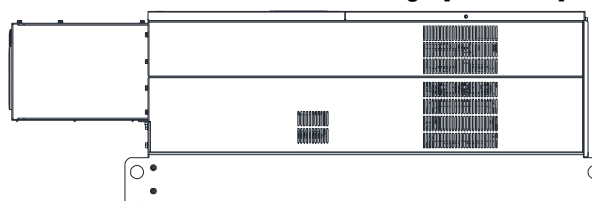

Figure 3-98

VFD2800C43A; VFD3150C43A; VFD3550C43A; VFD4500C43A: 235kg / [518.1 lbs]  
VFDXXXC63B-00: 243.0kg / [535.7 lbs]

H1

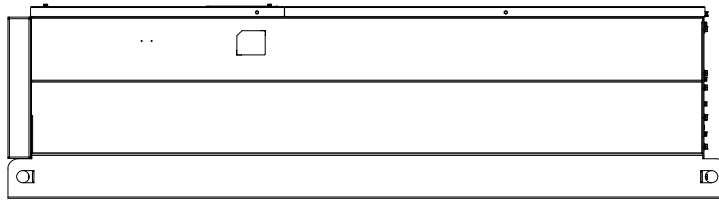

Figure 3-99

VFD2800C43E-1; VFD3150C43E-1; VFD3550C43E-1; VFD4500C43E-1: 257kg / [566.6 lbs]

H2

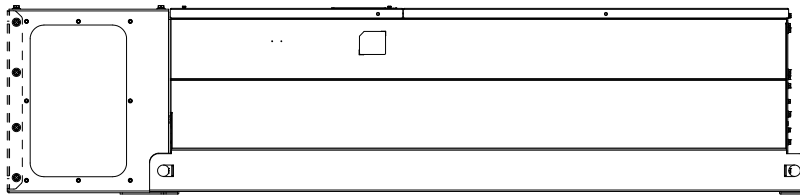

Figure 3-100

VFDXXXC63B-21: 251.0kg / [553.5 lbs]

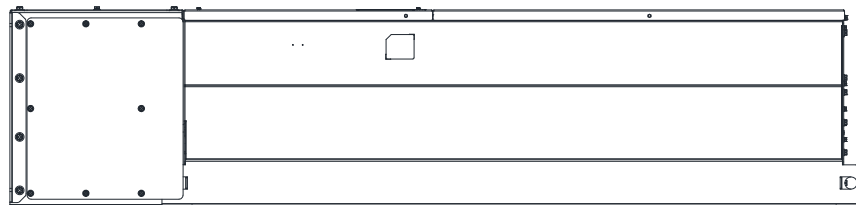

Figure 3-101

VFD2800C43E; VFD3150C43E; VFD3550C43E; VFD4500C43E: 257kg / [566.6 lbs]

H3

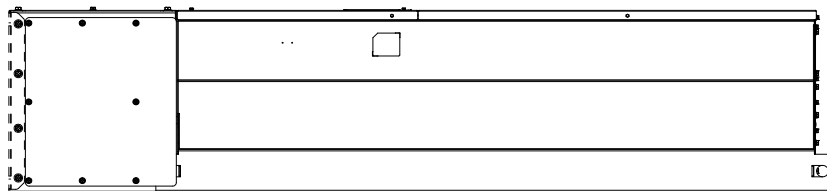

Figure 3-102

# ***Chapter 4 Wiring***

---

4-1 System Wiring Diagram

4-2 Wiring

After removing the front cover, examine if the power and control terminals are clearly noted. Please read following precautions before wiring.



- ☑ It is crucial to cut off the AC motor drive power before any wiring installation are made. A charge may still remain in the DCBUS capacitors with hazardous voltages even if the power has been turned off. Therefore, it is suggested for users to measure the remaining voltage by DC voltage meter before wiring. For your personnel safety, please do not perform any wiring before the voltage drops to a safe level  $< 25 V_{DC}$ . Wiring installation with remaining voltage condition may cause sparks and short circuit.
- ☑ Only qualified personnel familiar with AC motor drives is allowed to perform installation, wiring and commissioning. Make sure the power is turned off before wiring to prevent electric shock.
- ☑ Make sure that power is only applied to the R/L1, S/L2, T/L3 terminals. Failure to comply may result in damage to the equipment. The voltage and current should lie within the range as indicated on the nameplate (Chapter 1-1 Nameplate Information).
- ☑ All the units must be grounded directly to a common ground terminal to prevent lightning strike or electric shock.
- ☑ Please make sure to fasten the screw of the main circuit terminals to prevent sparks which is made by the loose screws due to vibration.



- ☑ When wiring, please choose the wires with specification that complies with local regulation for your personnel safety.
- ☑ Check following items after finishing the wiring:
  1. Are all connections correct?
  2. Any loosen wires?
  3. Any short-circuits between the terminals or to ground?

### 4-1 System Wiring Diagram

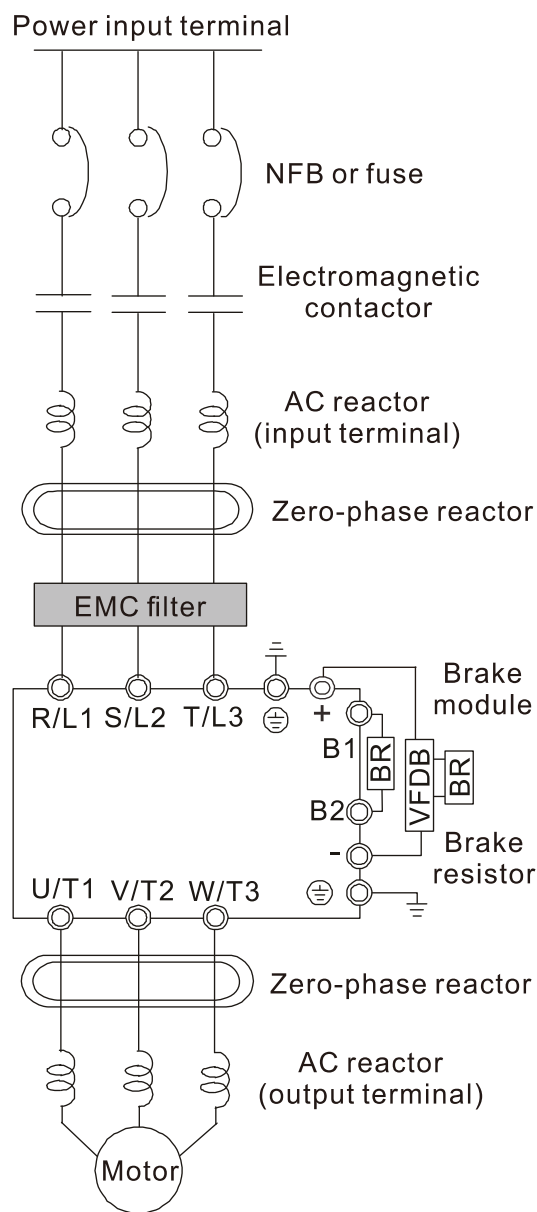

Figure 4-1

Note: Please refer to Chapter 4-2 Wiring Diagram for detailed wiring information.

Power input terminal	Please refer to Chapter 9 Specification Table in user manual for detail.
NFB or fuse	There may be a large inrush current during power on. Refer to 7-2 NFB to select a suitable NFB or 7-3 Fuse Specification Chart.
Electromagnetic contactor	Switching the power ON/OFF before the magnetic contactor more than 1 x per hour can cause damage to the drive.
AC reactor (input terminal)	When the mains power capacity is > 500kVA or when the drive is preceded by a capacitor bank, the instantaneous peaks voltages and current may destroy the drive. In that case it is recommended to install an AC input reactor which will also improve the power factor and harmonics. The cable between reactor and drive should be < 10m. Please refer to Chapter 7-4.
Zero-phase reactor	Used to reduce radiated emission, especially in environments with audio devices, and reduce input and output side interference. The effective range is AM band to 10MHz. Please refer to Chapter 7-5.
EMC filter	Can be used to reduce electromagnetic interference. Please refer to Chapter 7-6.
Brake module & Brake resistor (BR)	Used to shorten the deceleration time of the motor. Please refer to Chapter 7-1.
AC reactor (output terminal)	The wiring length of the motor will affect switching current peaks. It is recommended to install an AC output reactor when the motor wiring length exceeds the value listed in Chapter 7-4.

Table 4-1

## 4-2 Wiring

### Wiring Diagram for Frame A~C

Input: 3-phase power

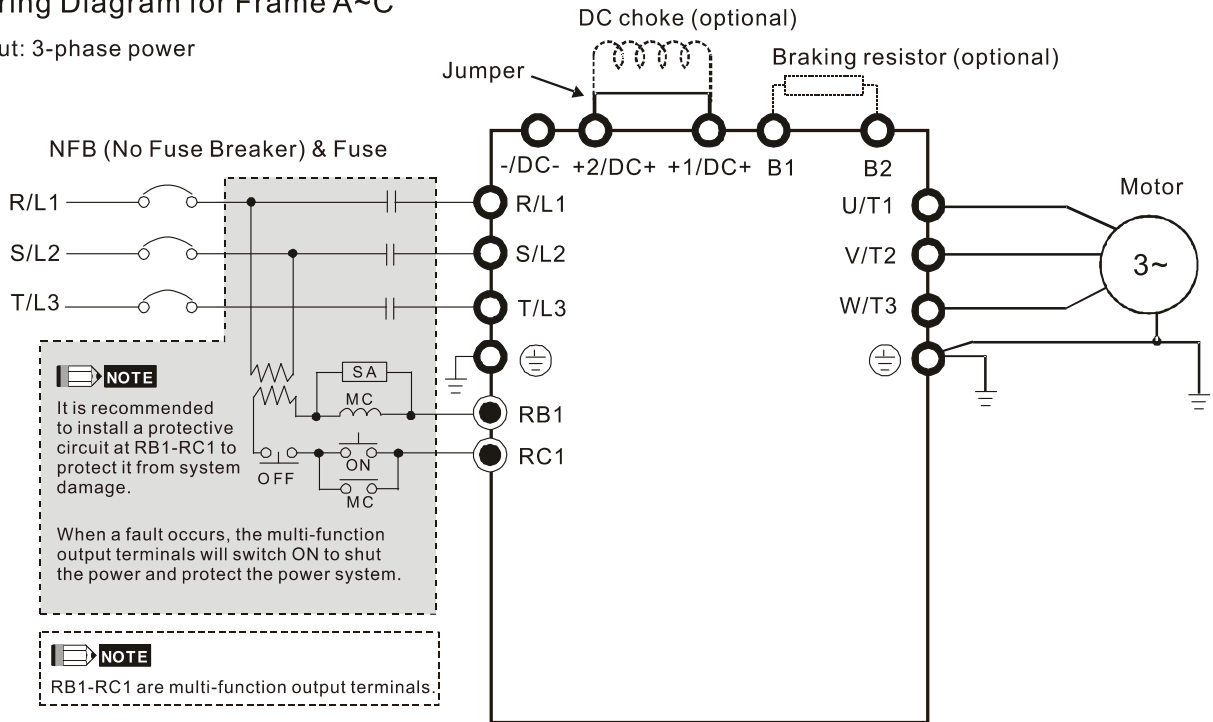

Figure 4-2

### Wiring Diagram for Frame D~F

Input: 3-phase power

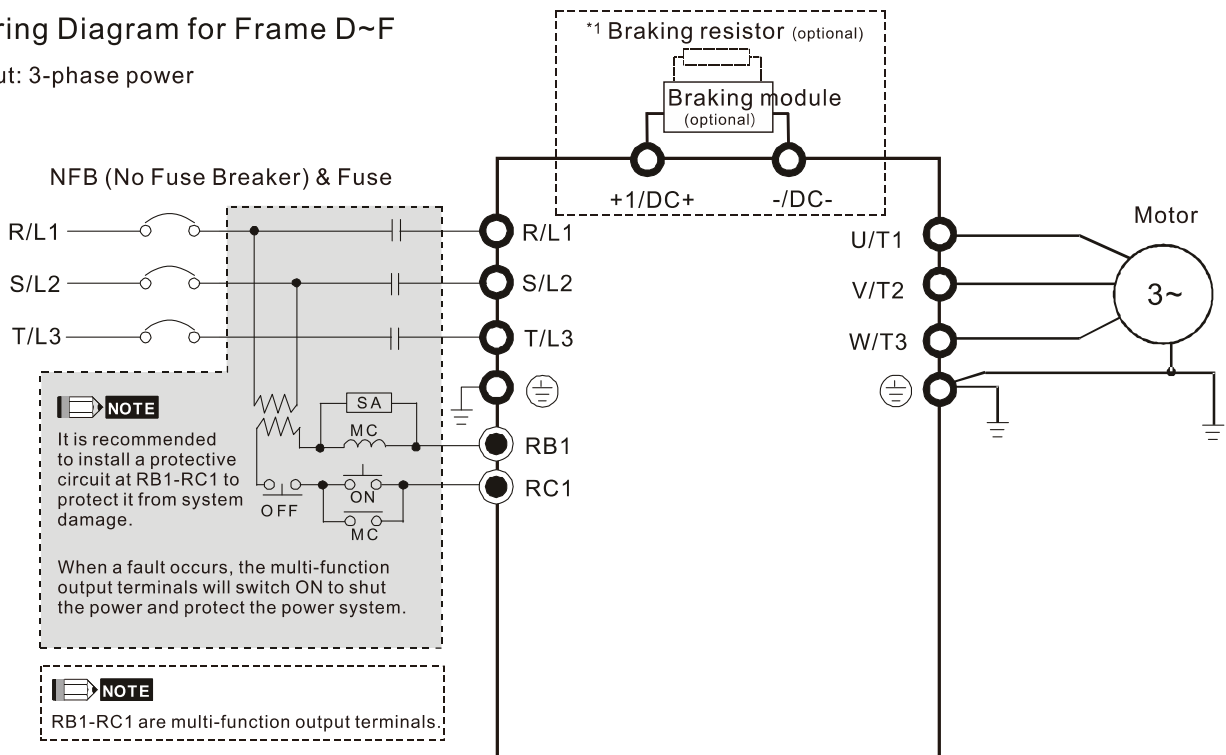

Figure 4-3

\*1 Please refer to Chapter 7-1 for brake units and resistors selection

Wiring Diagram for Frame G~H

Input: 3-phase power

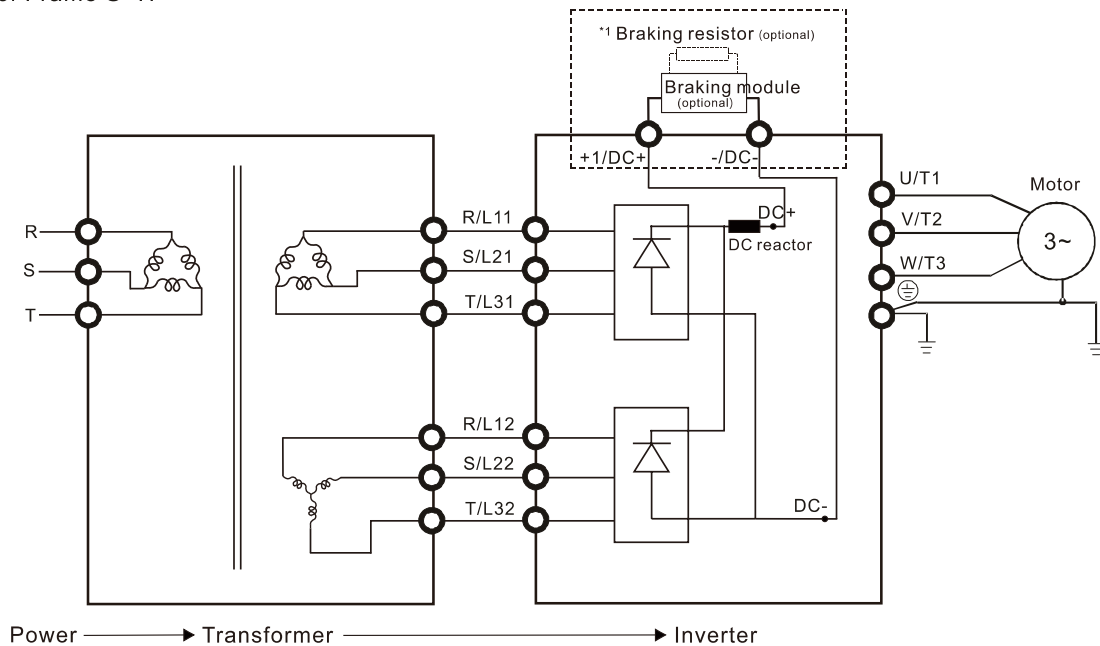

Figure 4-4

\*1 Please refer to Chapter 7-1 for brake units and resistors selection.

Note: When wiring for 12 Pulse Input, please strictly follow above wiring diagram, or it may cause the fan stop unexpectedly. Any questions, please contact Delta Electronics, Inc.



### Wiring Diagram for Frame A~H

Input: 3-phase power

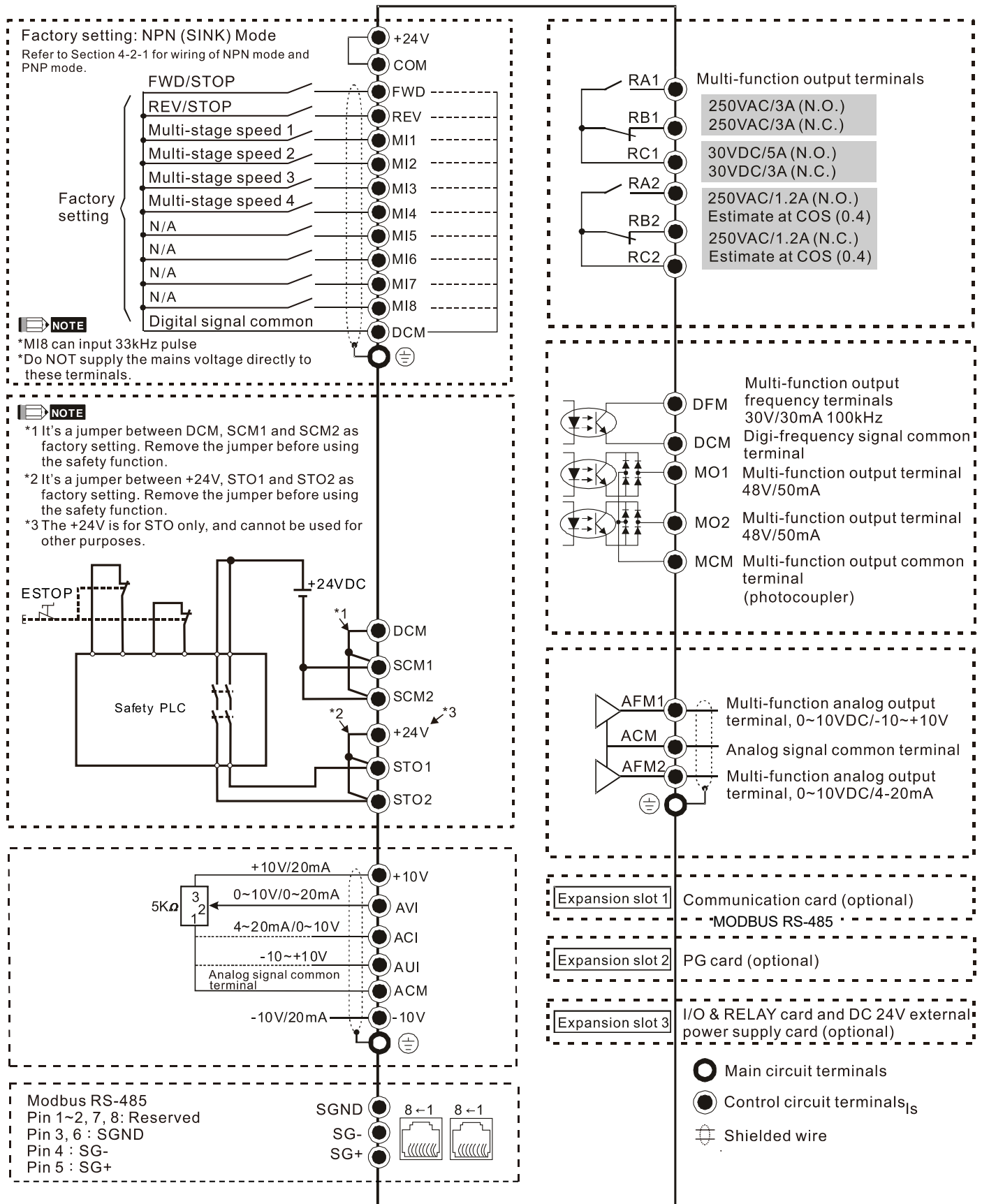
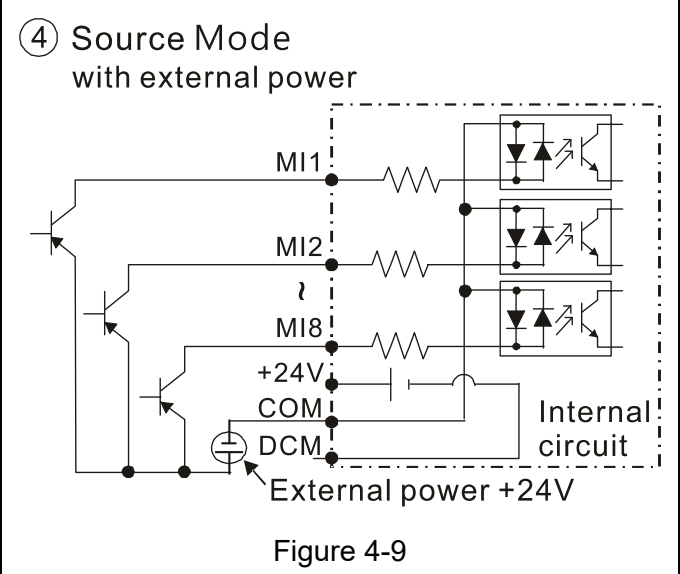
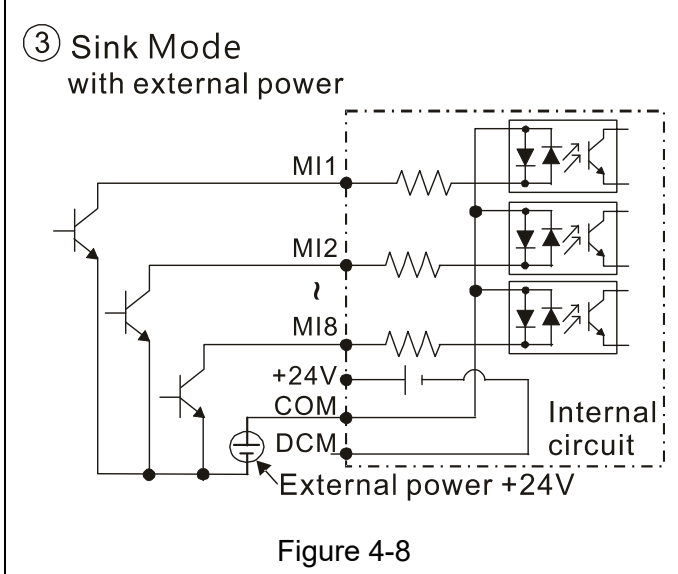
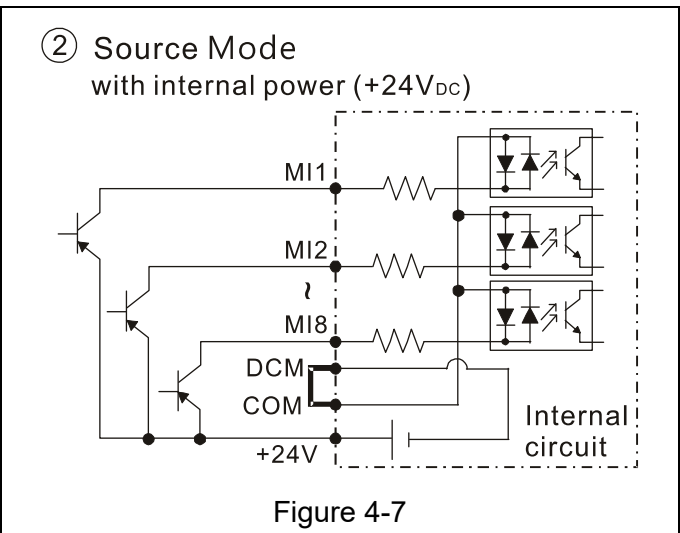
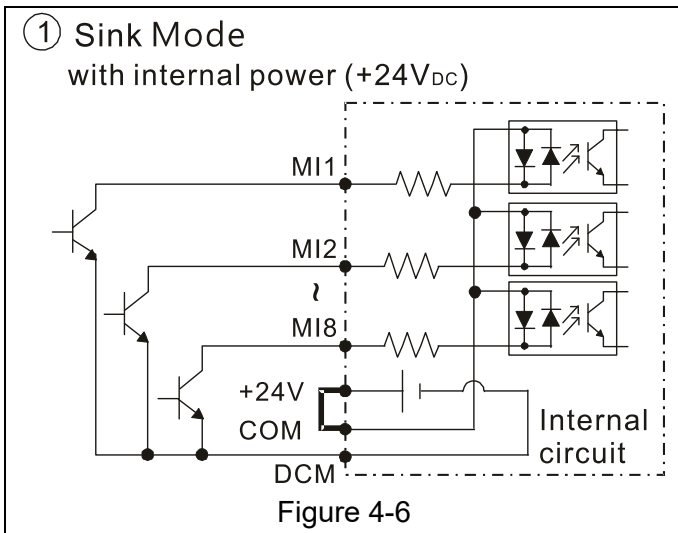

Figure 4-5

4-2-1 SINK (NPN) / SOURCE (PNP) Mode



[The page intentionally left blank]

# ***Chapter 5 Main Circuit Terminals***

---

5-1 Main Circuit Diagram

5-2 Specifications of Main Circuit Terminals



- ☑ Fasten the screws in the main circuit terminal to prevent sparks condition made by the loose screws due to vibration.
- ☑ When it needs to install the filter at the output side of terminals U/T1, V/T2, W/T3 on the AC motor drive. Please use inductance filter. Do not use phase-compensation capacitors or L-C (Inductance-Capacitance) or R-C (Resistance-Capacitance), unless approved by Delta.
- ☑ DO NOT connect phase-compensation capacitors or surge absorbers at the output terminals of AC motor drives.
- ☑ DO NOT connect [+1, -], [+2, -], [+1/DC+, -/DC-] or brake resistor directly to prevent drive damage.
- ☑ Ensure the insulation of the main circuit wiring in accordance with the relevant safety regulations.



### Main power terminals

- ☑ Do not connect 3-phase model to one-phase power. R/L1, S/L2 and T/L3 has no phase-sequence requirement, it can be used upon random selection.
- ☑ It is recommended to add a magnetic contactor (MC) to the power input wiring to cut off power quickly and reduce malfunction when activating the protection function of the AC motor drive. Both ends of the MC should have an R-C surge absorber.
- ☑ Please use voltage and current within the specification.
- ☑ When using a general GFCI (Ground Fault Circuit Interrupter), select a current sensor with sensitivity of 200mA or above and not less than 0.1-second operation time to avoid nuisance tripping.
- ☑ Please use the shielded wire or tube for the power wiring and ground the two ends of the shield wire or tube.
- ☑ Do NOT run/stop AC motor drives by turning the power ON/OFF. Run/stop AC motor drives by RUN/STOP command via control terminals or keypad. If you still need to run/stop AC motor drives by turning power ON/OFF, it is recommended to do so only ONCE per hour.
- ☑ Connect the drive to a 3-phase three-wire or 3-phase four-wire Wye system to comply with UL standards.

### Output terminals for main circuit

- ☑ Use well-insulated motor, suitable for inverter operation.
- ☑ When the AC drive output terminals U/T1, V/T2, and W/T3 are connected to the motor terminals U/T1, V/T2, and W/T3 respectively, the motor will rotate counterclockwise (as viewed on the shaft end of the motor, see the figure below) upon a forward operation command is received. To permanently reverse the direction of motor rotation, switch over any of the two motor leads.

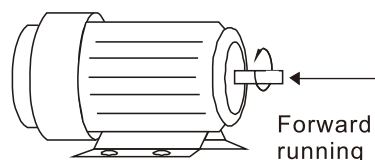

Figure 5-1

### Terminals for connecting DC reactor, external brake resistor, external brake resistor and DC circuit

- ☑ This is the terminals used to connect the DC reactor to improve the power factor. For the factory setting, it connects the short-circuit object. Please remove this short-circuit object before connecting to the DC reactor.

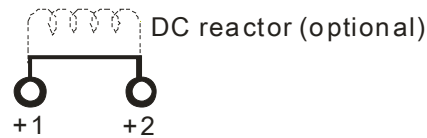

Figure 5-2

- ☑ Connect a brake resistor or brake unit in applications with frequent deceleration ramps, short deceleration time, too low brake torque or requiring increased brake torque.

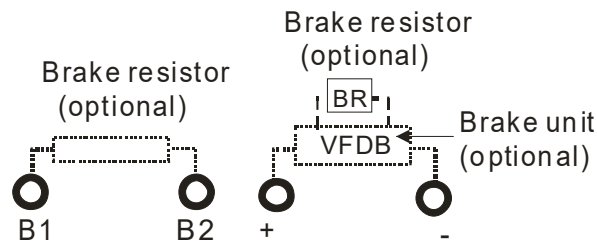

Figure 5-3

- ☑ The external brake resistor of Frame A, B and C should connect to the terminals (B1, B2) of AC motor drives.
- ☑ For those models without built-in brake resistor, please connect external brake unit and brake resistor (both of them are optional) to increase brake torque.
- ☑ When the terminals +1, +2 and - are not used, please leave the terminals open.
- ☑ DC+ and DC- are connected by common DCBUS, please refer to Chapter 5-1 (Main Circuit Terminal) for the wiring terminal specification and the wire gauge information.
- ☑ Please refer to the VFDB manual for more information on wire gauge when installing the brake unit.

### 5-1 Main Circuit Diagram

#### Wiring Diagram for Frame A~C

Input: 3-phase power

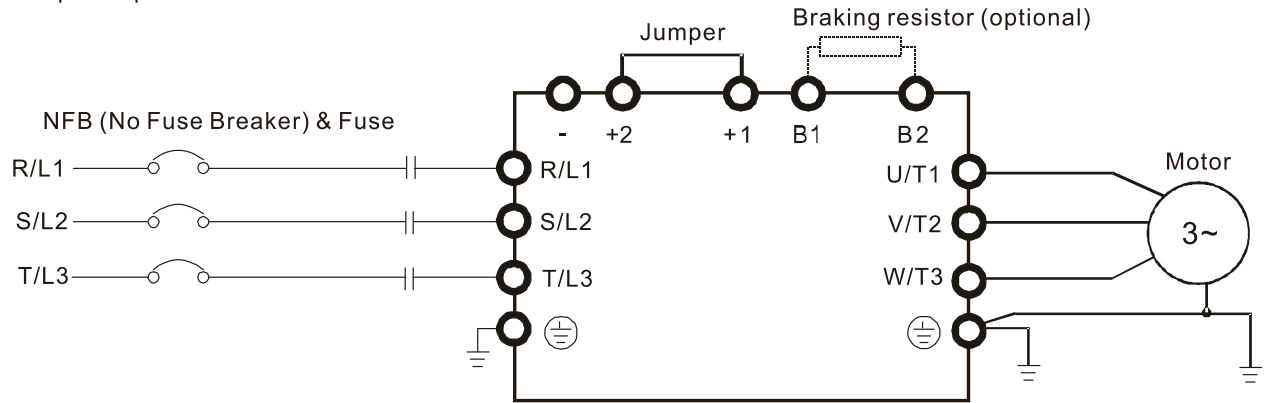

Figure 5-4

#### Wiring Diagram for Frame A~C

Input: 3-phase power

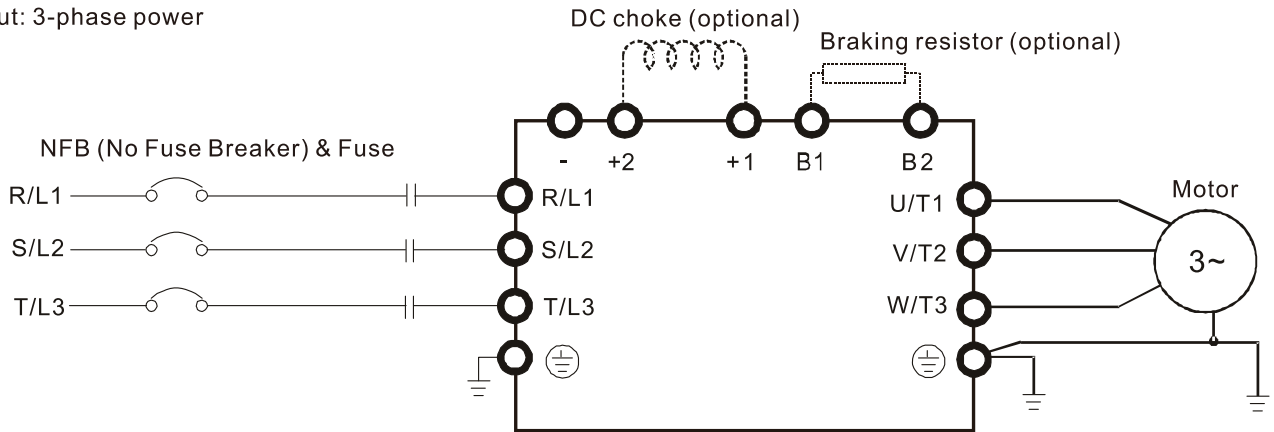

Figure 5-5

#### Wiring Diagram for Frame D~F

Input: 3-phase power

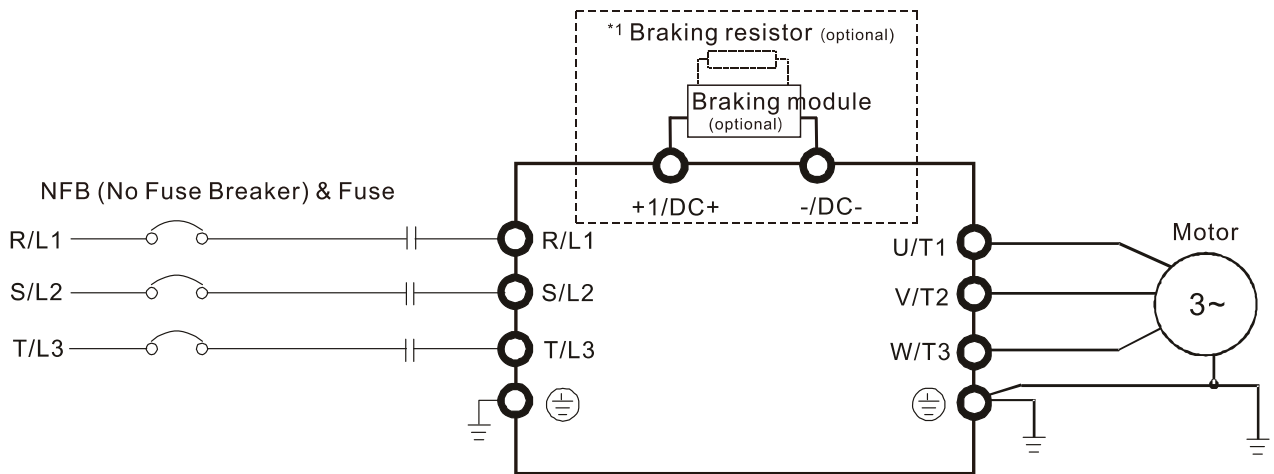

Figure 5-6

\*1 Please refer to Section 7-1 for more details of brake units.

Wiring Diagram for Frame G~H

Input: 3-phase power

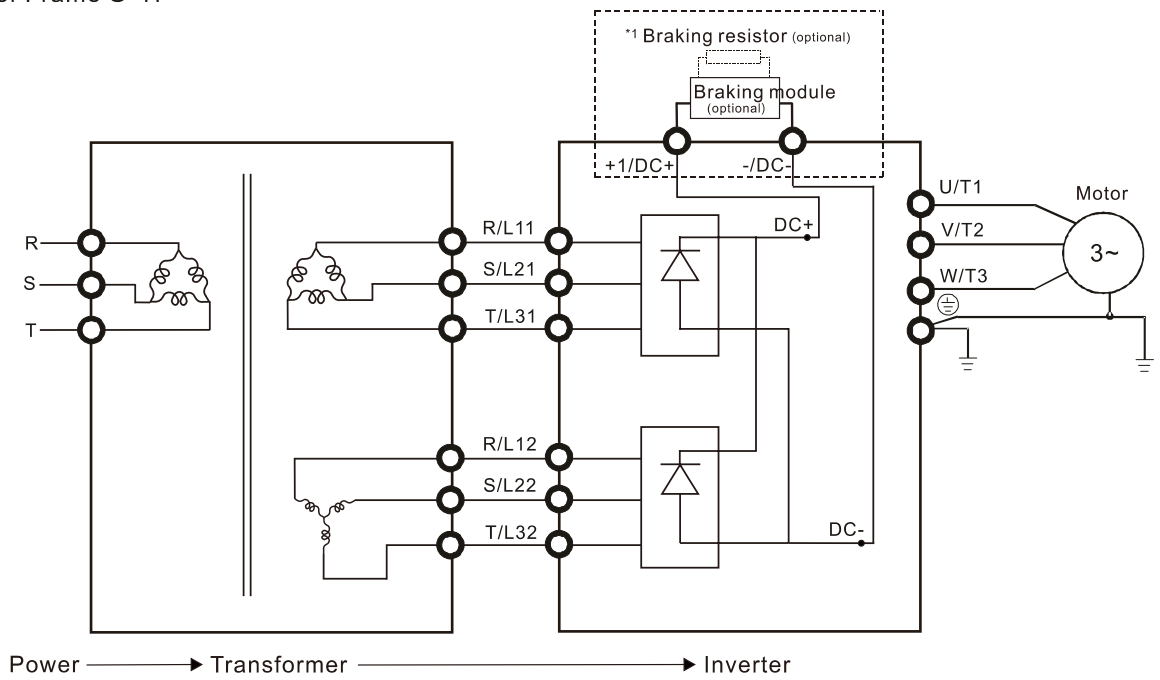

Figure 5-7

\*1 Please refer to Section 7-1 for brake units and resistors selection.

Note: When wiring for 12 Pulse Input, please strictly follow above wiring diagram, or it may cause the fan stop unexpectedly. Any questions, please contact Delta Electronics, Inc.

**NOTE**

- If the wiring between motor drive and motor is over 75 meters, please refer to Chapter 7-4 Specifications of limits for motor cable length.
- Please remove short circuit plate of Frame G and H if 12 pulse is implemented

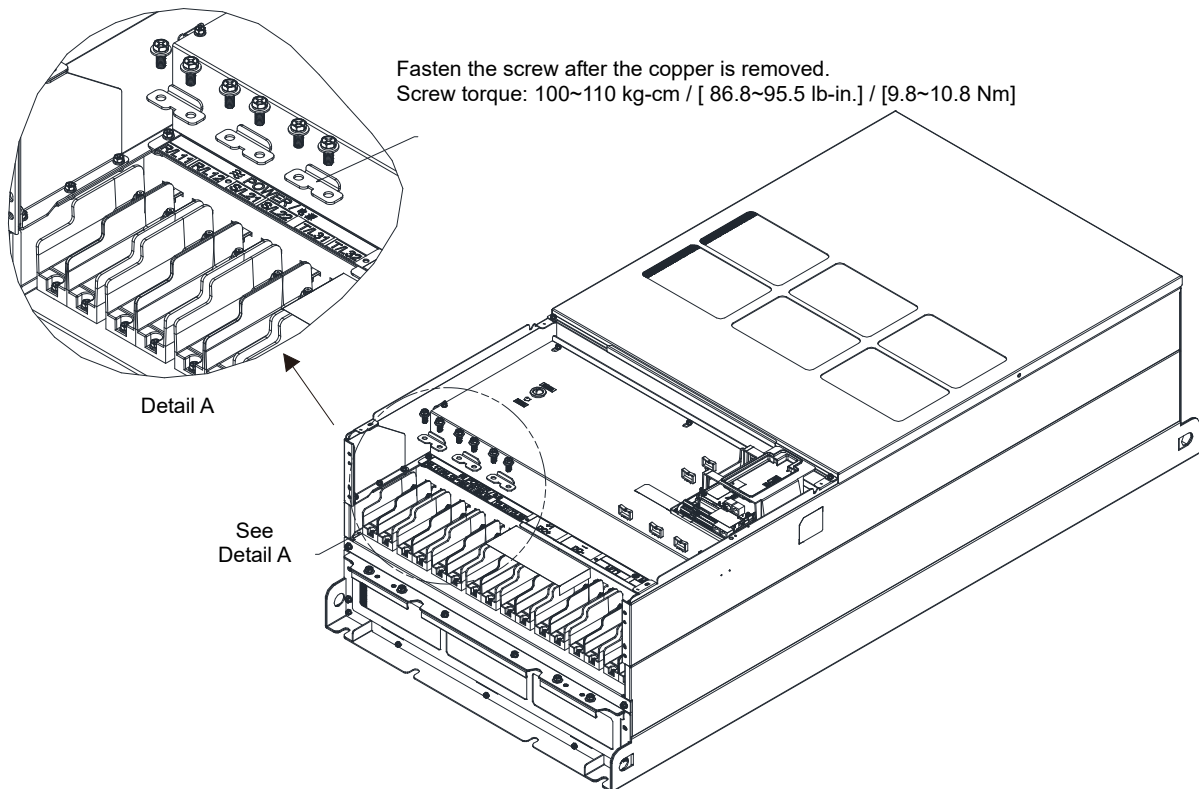

Figure 5-8



Terminals	Descriptions
R/L1, S/L2, T/L3	AC line input terminals 3-phase
U/T1, V/T2, W/T3	AC drive output terminals for connecting 3-phase induction motor
+1/DC+, +2/DC+	Applicable to frame A–C Connections for DC reactor to improve the power factor. It needs to remove the jumper for installation.
+1/DC+, -/DC-	Connections for brake module (VFDB series) (for 230V models: ≤ 22kW, built-in brake module) (for 460V models: ≤ 30kW, built-in brake module) Common DC BUS
B1, B2	Connections for brake resistor (optional)
	Earth connection, please comply with local regulations.

Table 5-1

## 5-2 Specifications of Main Circuit Terminals

- Use the specified ring lug for main circuit terminal wiring. See figure 5-9 and figure 5-10 for ring lug specifications. For other types of wiring use the wires that comply with the local regulations.
- After crimping the wire to the ring lug (must be UL approved), UL and CSA approved recognized component (YDPU2), install heat shrink tube rated at a minimum of 600V<sub>AC</sub> insulation over the live part. Refer to figure 5-10 below.

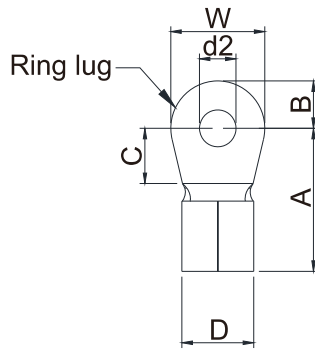

Figure 5-9

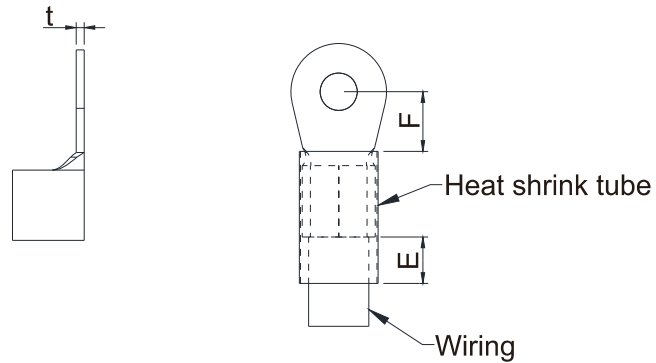

Figure 5-10

### Terminal specification

The part number of the ring lugs (produced by K.S. Terminals Inc.) in the table below are for reference only. You can buy the ring lugs of your choice to match with different frame sizes.

Frame	AWG	Kit P/N	A (MAX)	B (MAX)	C (MIN)	D (MAX)	d2 (MIN)	E (MIN)	F (MIN)	W (MAX)	t (MAX)
A	16	RNBL2-4	20.0	5.0	5.5	9.0	4.3	8.0	5.5	10.0	1.5
	14	RNBL2-4									
	12	RNBL5-4									
	10	RNBL5-4									
	8	RNBS8-4									
B	8	RNBM8-5	28.0	7.0	7.5	14.0	5.2	13.0	12.0	14.0	1.5
	6	RNB14-5									
	4	RNBS22-5									
C	6	RNB14-8	40.0	12.0	12.5	22.0	8.3	13.0	12.5	24.0	2.5
	4	RNB22-8									
	2	RNBS38-8									
	1/0	RNB60-8									
D0	4	RNB22-8	44.0	13.0	10.0	15.0	8.3	13.0	17.0	26.0	3.0
	2	RNBS38-8									
	1/0	SQNBS60-8	40.0	11.0	10.0	23.0	8.3	13.0	14.0*1	24.0	4.5
	2/0	SQNBS80-8									
D	4	RNB22-8	50.0	16.0	10.0	27.0	8.3	13.0	14.0	28.0	6.0
	2	RNBS38-8									
	1/0	RNB60-8									
	2/0	RNB70-8									
	3/0	RNB80-8									
	4/0	SQNBS100-8									
	250MCM	SQNBS150-8									
	300MCM	SQNBS150-8									

Chapter 5 Main Circuit Terminals | C2000

Frame	AWG	Kit P/N	A (MAX)	B (MAX)	C (MIN)	D (MAX)	d2 (MIN)	E (MIN)	F (MIN)	W (MAX)	t (MAX)
E	1/0	RNB60-8	53.0	16.0	17.0	26.5	8.4	13.0	17.0	31.0	5.0
	2/0	RNB70-8									
	3/0	RNB80-8									
	4/0	RNB100-8									
F	3/0	RNB80-8	55.0	15.0	10.0	27.0	8.3	13.0	17.5	31.0	6.0
	4/0	SQNBS100-8									
	300MCM	SQNBS150-8									
G	1/0	SQNBS60-8	54.0	15.5	18.0	26.5	8.2	13.0	18.0	31.0	3.5
	2/0	SQNBS80-8									
	3/0	SQNBS80-8									
	4/0	SQNBS100-8									
	250MCM	SQNBS150-8	70.0	21.0	27.0	32.7	12.2	13.0	27.0	42.0	4.0
	300MCM	SQNBS180-12									
	400MCM	SQNBS200-12									
	500MCM	SQNBS200-12									
H	3/0	SQNBS80-8	54.0	15.5	18.0	26.5	8.2	13.0	18.0	31.0	3.5
	4/0	SQNBS100-8									
	250	SQNBS150-8									
	300	SQNBS150-8									
	350	SQNBS150-8									

\*1: F(MAX)=16.5

Unit: mm

## Frame A

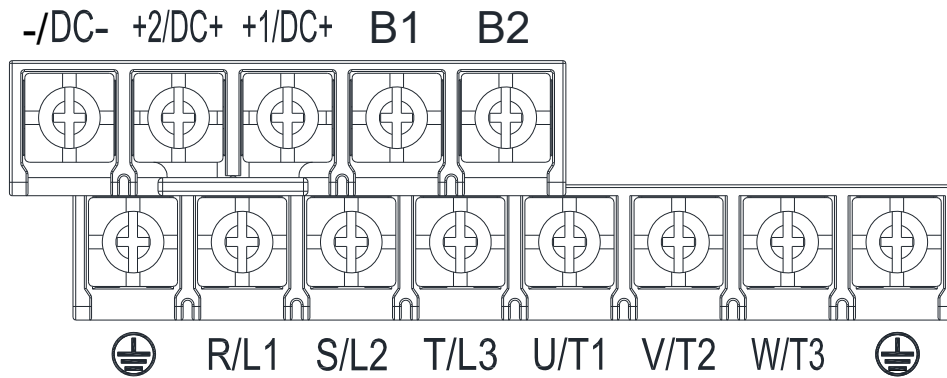

- If you install at Ta 50°C environment, please select copper wire with voltage rating 600V and temperature resistant 75°C or 90°C.
- If you install at Ta 50°C above environment, please select copper wire with voltage rating 600V and temperature resistant at 90°C or above.
- For UL installation compliant, please use copper wires for installation, the wire gauge is based on temperature resistant at 75°C which is requested and recommended from UL. Do not reduce the wire gauge when using higher temperature wire.

Model Name	Main Circuit Terminals R/L1, S/L2, T/L3, U/T1, V/T2, W/T3, DC+, DC, B1, B2			Terminal			
	Max. Wire Gauge	Min. Wire Gauge	Screw Spec. and Torque (±10%)	Max. Wire Gauge	Min. Wire Gauge	Screw Spec. and Torque (±10%)	
VFD007C23A	10 mm <sup>2</sup> [8 AWG]	2.5 mm <sup>2</sup> [14 AWG]	M4 20kg-cm [17.4 lb-in.] [1.96Nm]	2.5 mm <sup>2</sup> [14 AWG]	2.5 mm <sup>2</sup> [14 AWG]	M4 20kg-cm [17.4 lb-in.] [1.96Nm]	
VFD015C23A		4.0 mm <sup>2</sup> [12 AWG]		4.0 mm <sup>2</sup> [12 AWG]	4.0 mm <sup>2</sup> [12 AWG]		
VFD022C23A		6.0 mm <sup>2</sup> [10 AWG]		6.0 mm <sup>2</sup> [10 AWG]	6.0 mm <sup>2</sup> [10 AWG]		
VFD037C23A		10.0 mm <sup>2</sup> [8 AWG]		10.0 mm <sup>2</sup> [8 AWG]	10.0 mm <sup>2</sup> [8 AWG]		
VFD007C43A		1.5 mm <sup>2</sup> [16 AWG]		2.5 mm <sup>2</sup> [14 AWG]	2.5 mm <sup>2</sup> [14 AWG]		2.5 mm <sup>2</sup> [14 AWG]
VFD015C43A		2.5 mm <sup>2</sup> [14 AWG]					
VFD022C43A		2.5 mm <sup>2</sup> [14 AWG]		6.0 mm <sup>2</sup> [10 AWG]	6.0 mm <sup>2</sup> [10 AWG]		6.0 mm <sup>2</sup> [10 AWG]
VFD037C43A		6.0 mm <sup>2</sup> [10 AWG]					
VFD040C43A		6.0 mm <sup>2</sup> [10 AWG]					
VFD055C43A		1.5 mm <sup>2</sup> [16 AWG]		2.5 mm <sup>2</sup> [14 AWG]	2.5 mm <sup>2</sup> [14 AWG]		2.5 mm <sup>2</sup> [14 AWG]
VFD007C43E		2.5 mm <sup>2</sup> [14 AWG]					
VFD015C43E		2.5 mm <sup>2</sup> [14 AWG]		6.0 mm <sup>2</sup> [10 AWG]	6.0 mm <sup>2</sup> [10 AWG]		6.0 mm <sup>2</sup> [10 AWG]
VFD022C43E		6.0 mm <sup>2</sup> [10 AWG]					
VFD037C43E		6.0 mm <sup>2</sup> [10 AWG]					
VFD040C43E		6.0 mm <sup>2</sup> [10 AWG]		2.5 mm <sup>2</sup> [14 AWG]	2.5 mm <sup>2</sup> [14 AWG]		2.5 mm <sup>2</sup> [14 AWG]
VFD055C43E		2.5 mm <sup>2</sup> [14 AWG]					
VFD015C53A-21		2.5 mm <sup>2</sup> [14 AWG]					
VFD022C53A-21	2.5 mm <sup>2</sup> [14 AWG]						
VFD037C53A-21	2.5 mm <sup>2</sup> [14 AWG]						

**Frame B**

-/DC- +2/DC+ +1/DC+ B1 B2

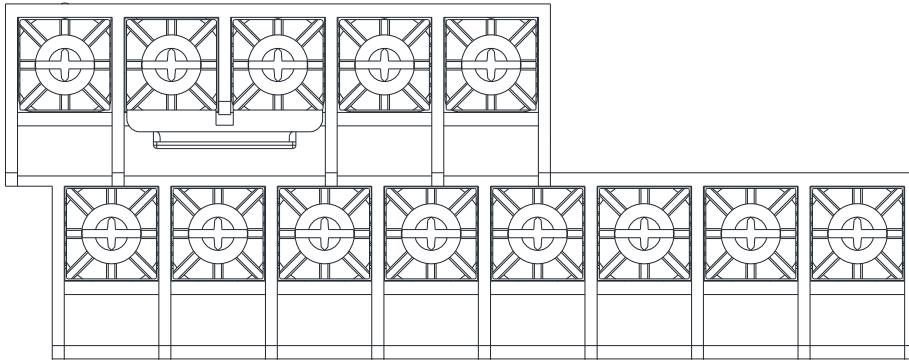

⊥ R/L1 S/L2 T/L3 U/T1 V/T2 W/T3 ⊥

- If you install at Ta 50°C environment, please select copper wire with voltage rating 600V and temperature resistant 75°C or 90°C.
- If you install at Ta 50°C above environment, please select copper wire with voltage rating 600V and temperature resistant at 90°C or above.
- For VFD110C23A, if you install at Ta 45°C above environment, please select copper wire with voltage rating 600V and temperature resistant at 90°C or above.
- For UL installation compliant, please use copper wires for installation, the wire gauge is based on temperature resistant at 75°C which is requested and recommended from UL. Do not reduce the wire gauge when using higher temperature wire.
- Wire fix to pole +2/DC+ and +1/DC+ with 45 kg-cm / [39.0 lb-in] / [4.42 Nm] (±10%)

Model Name	Main Circuit Terminals R/L1, S/L2, T/L3, U/T1, V/T2, W/T3, -/DC-, +1/DC+, +2/DC+, B1, B2			Terminal ⊥			
	Max. Wire Gauge	Min. Wire Gauge	Screw Spec. and Torque (±10%)	Max. Wire Gauge	Min. Wire Gauge	Screw Spec. and Torque (±10%)	
VFD055C23A	25 mm <sup>2</sup> [4 AWG]	10 mm <sup>2</sup> [8 AWG]	M5 35kg-cm [30.4 lb-in.] [3.43Nm]	10 mm <sup>2</sup> [8 AWG]	10 mm <sup>2</sup> [8 AWG]	M5 35kg-cm [30.4 lb-in.] [3.43Nm]	
VFD075C23A		16 mm <sup>2</sup> [6 AWG]		16 mm <sup>2</sup> [6 AWG]	16 mm <sup>2</sup> [6 AWG]		
VFD110C23A		25 mm <sup>2</sup> [4 AWG]		25 mm <sup>2</sup> [4 AWG]	16 mm <sup>2</sup> [6 AWG]		
VFD075C43A		10 mm <sup>2</sup> [8 AWG]		10 mm <sup>2</sup> [8 AWG]	10 mm <sup>2</sup> [8 AWG]		10 mm <sup>2</sup> [8 AWG]
VFD075C43E							
VFD110C43A		16 mm <sup>2</sup> [6 AWG]		16 mm <sup>2</sup> [6 AWG]	16 mm <sup>2</sup> [6 AWG]		16 mm <sup>2</sup> [6 AWG]
VFD110C43E							
VFD150C43A		6 mm <sup>2</sup> [10 AWG]		6 mm <sup>2</sup> [10 AWG]	6 mm <sup>2</sup> [10 AWG]		6 mm <sup>2</sup> [10 AWG]
VFD150C43E							
VFD055C53A-21		10 mm <sup>2</sup> [8 AWG]		10 mm <sup>2</sup> [8 AWG]	10 mm <sup>2</sup> [8 AWG]		10 mm <sup>2</sup> [8 AWG]
VFD075C53A-21							
VFD110C53A-21							
VFD150C53A-21							

**Frame C**

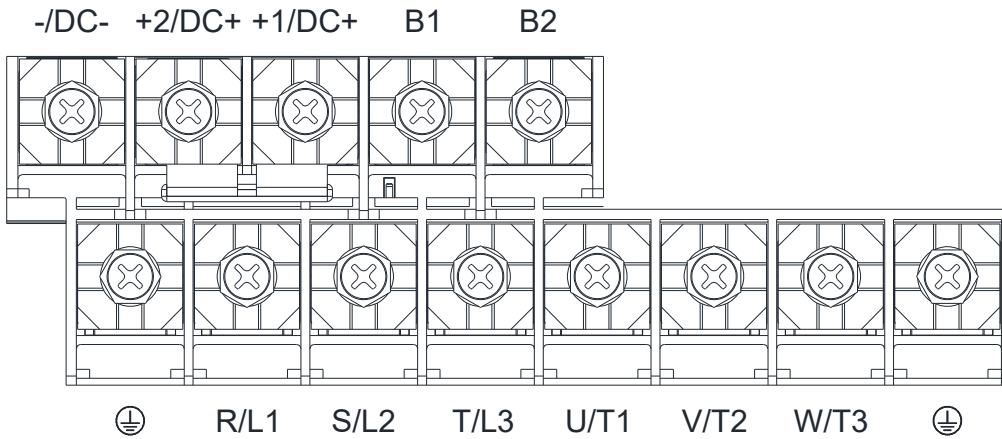

- If you install at Ta 50°C environment, please select copper wire with voltage rating 600V and temperature resistant 75°C or 90°C.
- If you install at Ta 50°C above environment, please select copper wire with voltage rating 600V and temperature resistant at 90°C or above.
- For VFD220C23A, if you install at Ta 40°C above environment, please select copper wire with voltage rating 600V and temperature resistant at 90°C or above.
- For UL installation compliant, please use copper wires for installation, the wire gauge is based on temperature resistant at 75°C which is requested and recommended from UL. Do not reduce the wire gauge when using higher temperature wire.
- Wire fix to pole +2/DC+ and +1/DC+ with 90 kg-cm / [78.2 lb-in] / [8.83 Nm] (±10%)

Model Name	Main Circuit Terminals R/L1, S/L2, T/L3, U/T1, V/T2, W/T3, -/DC-, +1/DC+, +2/DC+, B1, B2			Terminal ⊕		
	Max. Wire Gauge	Min. Wire Gauge	Screw Spec. and Torque (±10%)	Max. Wire Gauge	Min. Wire Gauge	Screw Spec. and Torque (±10%)
VFD150C23A	50mm <sup>2</sup> [1/0 AWG]	50 mm <sup>2</sup> [1/0 AWG]	M8 80kg-cm [69.4 lb-in.] [7.84Nm]	50 mm <sup>2</sup> [1/0 AWG]	25 mm <sup>2</sup> [4 AWG]	M8 80kg-cm [69.4 lb-in.] [7.84Nm]
VFD185C23A						
VFD220C23A						
VFD185C43A		25 mm <sup>2</sup> [4 AWG]		25 mm <sup>2</sup> [4 AWG]	16 mm <sup>2</sup> [6 AWG]	
VFD220C43A						
VFD300C43A		35 mm <sup>2</sup> [2 AWG]		35 mm <sup>2</sup> [2 AWG]	16 mm <sup>2</sup> [6 AWG]	
VFD185C43E		25 mm <sup>2</sup> [4 AWG]		25 mm <sup>2</sup> [4 AWG]		
VFD220C43E		35 mm <sup>2</sup> [2 AWG]		35 mm <sup>2</sup> [2 AWG]	16 mm <sup>2</sup> [6 AWG]	
VFD300C43E						
VFD185C63B-21		10 mm <sup>2</sup> [8 AWG]		10 mm <sup>2</sup> [8 AWG]	10 mm <sup>2</sup> [8 AWG]	
VFD220C63B-21		16 mm <sup>2</sup> [6 AWG]		16 mm <sup>2</sup> [6 AWG]	16 mm <sup>2</sup> [6 AWG]	
VFD300C63B-21		25 mm <sup>2</sup> [4 AWG]		25 mm <sup>2</sup> [4 AWG]		
VFD370C63B-21		35 mm <sup>2</sup> [2 AWG]		35 mm <sup>2</sup> [2 AWG]		

**Frame D0**

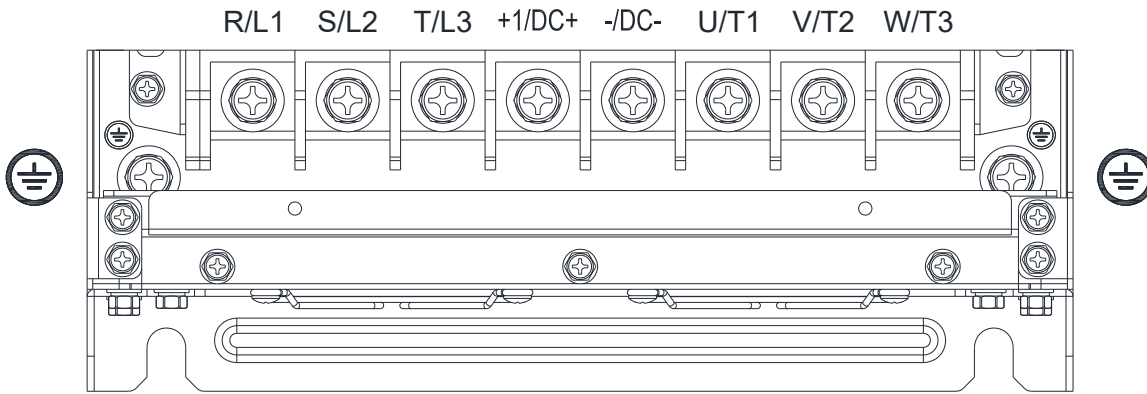

- If you install at Ta 40°C (for model names with last digit U) / 50°C (for model names with last digit S) environment, please select copper wire with voltage rating 600V and temperature resistant at 75°C or 90°C.
- If you install at Ta 40°C (for model names with last digit U) / 50°C (for model names with last digit S) above environment, please select copper wire with voltage rating 600V and temperature resistant at 90°C or above.
- For UL installation compliant, please use copper wires for installation, the wire gauge is based on temperature resistant at 75°C which is requested and recommended from UL. Do not reduce the wire gauge when using higher temperature wire.

Model Name	Main Circuit Terminals R/L1, S/L2, T/L3, U/T1, V/T2, W/T3, DC+, DC-			Terminal Ⓟ		
	Max. Wire Gauge	Min. Wire Gauge	Screw Spec. and Torque (±10%)	Max. Wire Gauge	Min. Wire Gauge	Screw Spec. and Torque (±10%)
VFD370C43U	70mm <sup>2</sup> [2/0 AWG]	50 mm <sup>2</sup> [1/0 AWG]	M8 80kg-cm [69.4 lb-in.] [7.84Nm]	35 mm <sup>2</sup> [2 AWG]	25 mm <sup>2</sup> [4 AWG]	M8 80kg-cm [69.4 lb-in.] [7.84Nm]
VFD450C43U						
VFD370C43S						
VFD450C43S		70 mm <sup>2</sup> [2/0 AWG]				

## Frame D

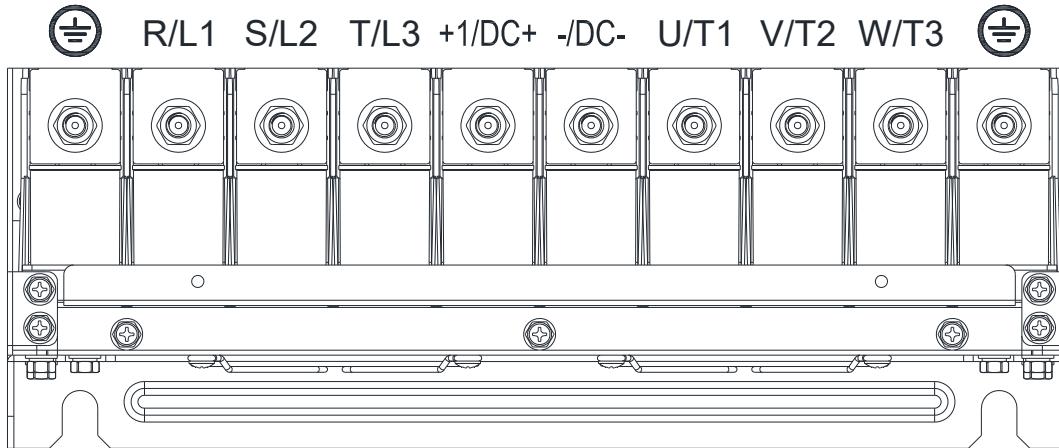

- If you install at Ta 50°C (for 230V / 460V model names with last digit A; for 690V model names end with 63B-00) / 40°C (for 230V / 460V model names with last digit A; for 690V model names end with 63B-21) environment, please select copper wire with voltage rating 600V and temperature resistant at 75°C or 90°C.
- If you install at Ta 50°C (for 230V / 460V model names with last digit A; for 690V model names end with 63B-00) / 40°C (for 230V / 460V model names with last digit A; for 690V model names end with 63B-21) above environment, please select copper wire with voltage rating 600V and temperature resistant at 90°C or above.
- For UL installation compliant, please use copper wires for installation, the wire gauge is based on temperature resistant at 75°C, which is requested and recommended from UL. Do not reduce the wire gauge when using higher temperature wire.

Model Name	Main Circuit Terminals R/L1, S/L2, T/L3, U/T1, V/T2, W/T3, DC+, DC-			Terminal				
	Max. Wire Gauge	Min. Wire Gauge	Screw Spec. and Torque (±10%)	Max. Wire Gauge	Min. Wire Gauge	Screw Spec. and Torque (±10%)		
VFD300C23A	150mm <sup>2</sup> [300MCM]	120 mm <sup>2</sup> [4/0 AWG]	M8 180kg-cm [156.2 lb-in.] [17.65Nm]	120 mm <sup>2</sup> [4/0 AWG]	70 mm <sup>2</sup> [2/0 AWG]	M8 180kg-cm [156.2 lb-in.] [17.65Nm]		
VFD370C23A		120 mm <sup>2</sup> [250MCM]		120 mm <sup>2</sup> [250MCM]	70 mm <sup>2</sup> [2/0 AWG]			
VFD370C43A		50 mm <sup>2</sup> [1/0 AWG]		50 mm <sup>2</sup> [1/0 AWG]	25 mm <sup>2</sup> [4 AWG]			
VFD450C43A		70 mm <sup>2</sup> [2/0 AWG]		70 mm <sup>2</sup> [2/0 AWG]	35 mm <sup>2</sup> [2 AWG]			
VFD550C43A		95 mm <sup>2</sup> [3/0 AWG]		95 mm <sup>2</sup> [3/0 AWG]	50 mm <sup>2</sup> [1/0 AWG]			
VFD750C43A		150 mm <sup>2</sup> [300MCM]		150 mm <sup>2</sup> [300MCM]	95 mm <sup>2</sup> [3/0 AWG]			
VFD300C23E	120mm <sup>2</sup> [4/0 AWG]	95 mm <sup>2</sup> [3/0 AWG]		95 mm <sup>2</sup> [3/0 AWG]	50 mm <sup>2</sup> [1/0 AWG]			
VFD370C23E		120 mm <sup>2</sup> [4/0 AWG]		120 mm <sup>2</sup> [4/0 AWG]	70 mm <sup>2</sup> [2/0 AWG]			
VFD370C43E		50 mm <sup>2</sup> [1/0 AWG]		50 mm <sup>2</sup> [1/0 AWG]	25 mm <sup>2</sup> [4 AWG]			
VFD450C43E		70 mm <sup>2</sup> [2/0 AWG]		70 mm <sup>2</sup> [2/0 AWG]	35 mm <sup>2</sup> [2 AWG]			
VFD550C43E		120 mm <sup>2</sup> [4/0 AWG]		120 mm <sup>2</sup> [4/0 AWG]	70 mm <sup>2</sup> [2/0 AWG]			
VFD750C43E		120 mm <sup>2</sup> [4/0 AWG]		120 mm <sup>2</sup> [4/0 AWG]	70 mm <sup>2</sup> [2/0 AWG]			
VFD450C63B-00	150mm <sup>2</sup> [300MCM]	35 mm <sup>2</sup> [2 AWG]			35 mm <sup>2</sup> [2 AWG]		16 mm <sup>2</sup> [6 AWG]	
VFD550C63B-00								
VFD450C63B-21								
VFD550C63B-21								



**Frame E**

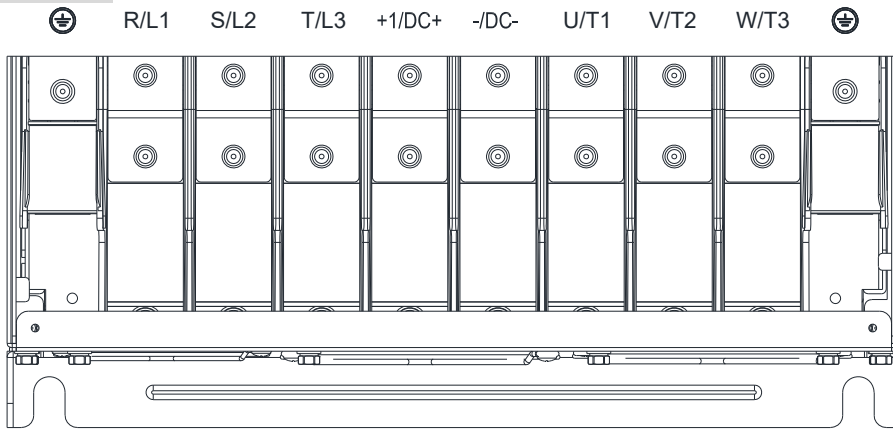

- If you install at Ta 50°C (for 230V / 460V model names with last digit A; for 690V model names end with 63B-00) / 40°C (for 230V / 460V model names with last digit A; for 690V model names end with 63B-21) environment, please select copper wire with voltage rating 600V and temperature resistant at 75°C or 90°C.
- If you install at Ta 50°C (for 230V / 460V model names with last digit A; for 690V model names end with 63B-00) / 40°C (for 230V / 460V model names with last digit A; for 690V model names end with 63B-21) above environment, please select copper wire with voltage rating 600V and temperature resistant at 90°C or above.
- For UL installation compliant, please use copper wires for installation, the wire gauge is based on temperature resistant at 75°C which is requested and recommended from UL. Do not reduce the wire gauge when using higher temperature wire.

Model Name	Main Circuit Terminals R/L1, S/L2, T/L3, U/T1, V/T2, W/T3, -/DC-, +1/DC+			Terminal		
	Max. Wire Gauge	Min. Wire Gauge	Screw Spec. and Torque (±10%)	Max. Wire Gauge	Min. Wire Gauge	Screw Spec. and Torque (±10%)
VFD450C23A	120mm <sup>2</sup> *2 [4/0 AWG*2]	50 mm <sup>2</sup> *2 [1/0 AWG*2]	M8 180kg-cm [156.2 lb-in.] [17.65 Nm]	50mm <sup>2</sup> *2 [1/0 AWG*2]	50 mm <sup>2</sup> *1 [1/0 AWG*1]	M8 180kg-cm [156.2 lb-in.] [17.65Nm]
VFD550C23A		95 mm <sup>2</sup> *2 [3/0 AWG*2]		95mm <sup>2</sup> *2 [3/0 AWG*2]	95 mm <sup>2</sup> *1 [3/0 AWG*1]	
VFD750C23A		120 mm <sup>2</sup> *2 [4/0 AWG*2]		120mm <sup>2</sup> *2 [4/0 AWG*2]	120 mm <sup>2</sup> *1 [4/0 AWG*1]	
VFD900C43A		50 mm <sup>2</sup> *2 [1/0 AWG*2]		50mm <sup>2</sup> *2 [1/0 AWG*2]	50 mm <sup>2</sup> *1 [1/0 AWG*1]	
VFD1100C43A		95 mm <sup>2</sup> *2 [3/0 AWG*2]		95mm <sup>2</sup> *2 [3/0 AWG*2]	95 mm <sup>2</sup> *1 [3/0 AWG*1]	
VFD450C23E		50 mm <sup>2</sup> *2 [1/0 AWG*2]		50mm <sup>2</sup> *2 [1/0 AWG*2]	50 mm <sup>2</sup> *1 [1/0 AWG*1]	
VFD550C23E		70 mm <sup>2</sup> *2 [2/0 AWG*2]		70mm <sup>2</sup> *2 [2/0 AWG*2]	70 mm <sup>2</sup> *1 [2/0 AWG*1]	
VFD750C23E		95 mm <sup>2</sup> *2 [3/0 AWG*2]		95mm <sup>2</sup> *2 [3/0 AWG*2]	95 mm <sup>2</sup> *1 [3/0 AWG*1]	
VFD900C43E		50 mm <sup>2</sup> *2 [1/0 AWG*2]		50mm <sup>2</sup> *2 [1/0 AWG*2]	50 mm <sup>2</sup> *1 [1/0 AWG*1]	
VFD1100C43E		70 mm <sup>2</sup> *2 [2/0 AWG*2]		70mm <sup>2</sup> *2 [2/0 AWG*2]	70 mm <sup>2</sup> *1 [2/0 AWG*1]	
VFD750C63B-00		25 mm <sup>2</sup> *2 [4 AWG*2]		25 mm <sup>2</sup> *2 [4 AWG*2]	25 mm <sup>2</sup> *1 [4 AWG*1]	
VFD900C63B-00		35 mm <sup>2</sup> *2 [2 AWG*2]		35 mm <sup>2</sup> *2 [2 AWG*2]	35 mm <sup>2</sup> *1 [2 AWG*1]	
VFD1100C63B-00		50 mm <sup>2</sup> *2 [1/0 AWG*2]		50 mm <sup>2</sup> *2 [1/0 AWG*2]	50 mm <sup>2</sup> *1 [1/0 AWG*1]	
VFD1320C63B-00		50 mm <sup>2</sup> *2 [1/0 AWG*2]		50 mm <sup>2</sup> *2 [1/0 AWG*2]	50 mm <sup>2</sup> *1 [1/0 AWG*1]	
VFD750C63B-21		25 mm <sup>2</sup> *2 [4 AWG*2]		25 mm <sup>2</sup> *2 [4 AWG*2]	25 mm <sup>2</sup> *1 [4 AWG*1]	
VFD900C63B-21		35 mm <sup>2</sup> *2 [2 AWG*2]		35 mm <sup>2</sup> *2 [2 AWG*2]	35 mm <sup>2</sup> *1 [2 AWG*1]	
VFD1100C63B-21		50 mm <sup>2</sup> *2 [1/0 AWG*2]		50 mm <sup>2</sup> *2 [1/0 AWG*2]	50 mm <sup>2</sup> *1 [1/0 AWG*1]	
VFD1320C63B-21		50 mm <sup>2</sup> *2 [1/0 AWG*2]		50 mm <sup>2</sup> *2 [1/0 AWG*2]	50 mm <sup>2</sup> *1 [1/0 AWG*1]	

**Frame F**

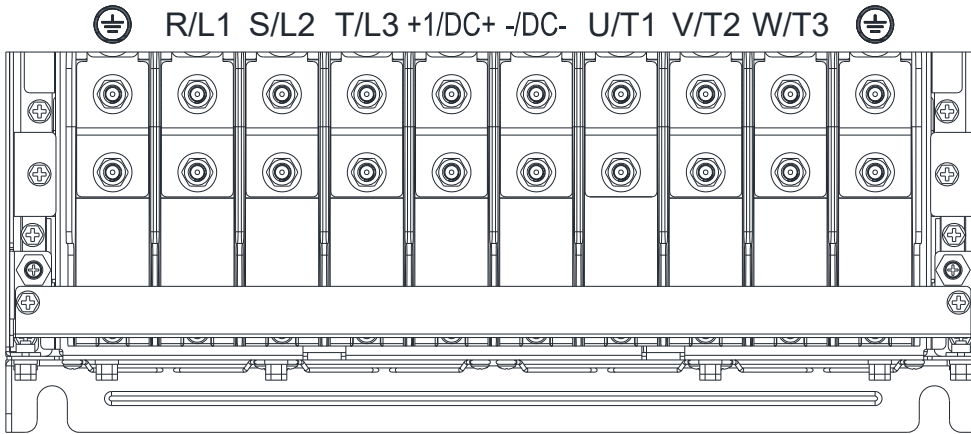

- If you install at Ta 50°C (for 230V / 460V model names with last digit A; for 690V model names end with 63B-00) / 40°C (for 230V / 460V model names with last digit A; for 690V model names end with 63B-21) environment, please select copper wire with voltage rating 600V and temperature resistant at 75°C or 90°C.
- If you install at Ta 50°C (for 230V / 460V model names with last digit A; for 690V model names end with 63B-00) / 40°C (for 230V / 460V model names with last digit A; for 690V model names end with 63B-21) above environment, please select copper wire with voltage rating 600V and temperature resistant at 90°C or above.
- For VFD900C23A, if you install at Ta 45°C above environment, please select copper wire with voltage rating 600V and temperature resistant at 90°C or above.
- For VFD900C23E, if you install at Ta 35°C above environment, please select copper wire with voltage rating 600V and temperature resistant at 90°C or above.
- For UL installation compliant, please use copper wires for installation, the wire gauge is based on temperature resistant at 75°C which is requested and recommended from UL. Do not reduce the wire gauge when using higher temperature wire.

Model Name	Main Circuit Terminals R/L1, S/L2, T/L3, U/T1, V/T2, W/T3, DC+, DC-			Terminal ⊕		
	Max. Wire Gauge	Min. Wire Gauge	Screw Spec. and Torque (±10%)	Max. Wire Gauge	Min. Wire Gauge	Screw Spec. and Torque (±10%)
VFD900C23A	150mm <sup>2</sup> *2 [300MCM*2]	150 mm <sup>2</sup> *2 [300MCM*2]	M8 180kg-cm [156.2 lb-in.] [17.65Nm]	150 mm <sup>2</sup> *2 [300MCM*2]	150 mm <sup>2</sup> [300MCM]	M8 180kg-cm [156.2 lb-in.] [17.65Nm]
VFD1320C43A		120 mm <sup>2</sup> *2 [4/0AWG*2]		120 mm <sup>2</sup> *2 [4/0AWG*2]	120 mm <sup>2</sup> [4/0AWG]	
VFD1600C43A		150 mm <sup>2</sup> *2 [300MCM*2]		150 mm <sup>2</sup> *2 [300MCM*2]	150 mm <sup>2</sup> [300MCM]	
VFD900C23E	120 mm <sup>2</sup> *2 [4/0AWG*2]	120 mm <sup>2</sup> *2 [4/0AWG*2]		120 mm <sup>2</sup> *2 [4/0AWG*2]	120 mm <sup>2</sup> [4/0AWG]	
VFD1320C43E		95 mm <sup>2</sup> *2 [3/0 AWG*2]		95 mm <sup>2</sup> *2 [3/0 AWG*2]	95 mm <sup>2</sup> [3/0 AWG]	
VFD1600C43E		120 mm <sup>2</sup> *2 [4/0AWG*2]		120 mm <sup>2</sup> *2 [4/0AWG*2]	120 mm <sup>2</sup> [4/0AWG]	
VFD1600C63B-00	150mm <sup>2</sup> *2 [300MCM*2]	70 mm <sup>2</sup> *2 [2/0 AWG*2]		70 mm <sup>2</sup> *2 [2/0 AWG*2]	70 mm <sup>2</sup> *1 [2/0 AWG*1]	
VFD2000C63B-00		95 mm <sup>2</sup> *2 [3/0 AWG*2]		95 mm <sup>2</sup> *2 [3/0 AWG*2]	95 mm <sup>2</sup> *1 [3/0 AWG*1]	
VFD1600C63B-21		70 mm <sup>2</sup> *2 [2/0 AWG*2]		70 mm <sup>2</sup> *2 [2/0 AWG*2]	70 mm <sup>2</sup> *1 [2/0 AWG*1]	
VFD2000C63B-21		95 mm <sup>2</sup> *2 [3/0 AWG*2]	95 mm <sup>2</sup> *2 [3/0 AWG*2]	95 mm <sup>2</sup> *1 [3/0 AWG*1]		

**Frame G**

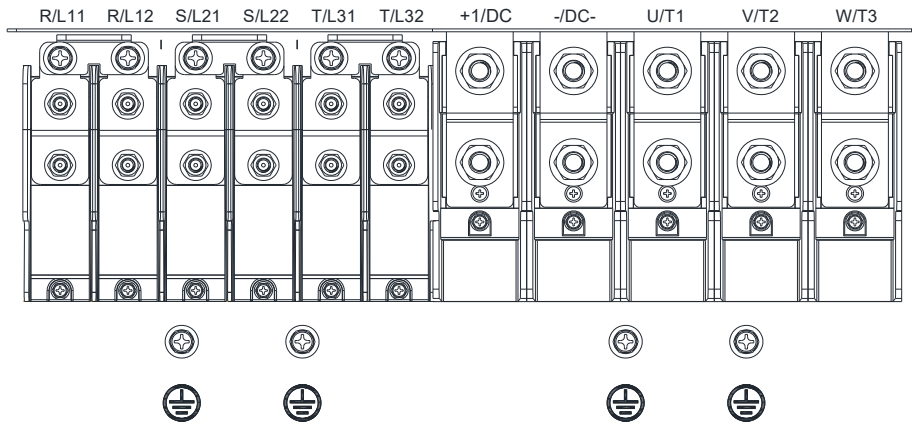

- If you install at Ta 50°C (for 230V / 460V model names with last digit A; for 690V model names end with 63B-00) / 40°C (for 230V / 460V model names with last digit A; for 690V model names end with 63B-21) environment, please select copper wire with voltage rating 600V and temperature resistant at 75°C or 90°C.
- If you install at Ta 50°C (for 230V / 460V model names with last digit A; for 690V model names end with 63B-00) / 40°C (for 230V / 460V model names with last digit A; for 690V model names end with 63B-21) above environment, please select copper wire with voltage rating 600V and temperature resistant at 90°C or above.
- For VFD2200C43A, if you install at Ta 45°C above environment, please select copper wire with voltage rating 600V and temperature resistant at 90°C or above.
- For UL installation compliant, please use copper wires for installation, the wire gauge is based on temperature resistant at 75°C which is requested and recommended from UL. Do not reduce the wire gauge when using higher temperature wire.

Model Name	Main Circuit Terminals R/L11, R/L12, S/L21, S/L22, T/L31, T/L32			Terminal			
	Max. Wire Gauge	Min. Wire Gauge	Screw Spec. and Torque (±10%)	Max. Wire Gauge	Min. Wire Gauge	Screw Spec. and Torque (±10%)	
VFD1850C43A	120mm <sup>2</sup> *4 [250MCM*4]	70 mm <sup>2</sup> *4 [2/0AWG*4]	M8 180kg-cm [156.2 lb-in.] [17.65Nm]	70 mm <sup>2</sup> *4 [2/0AWG*4]	70 mm <sup>2</sup> *2 [2/0AWG*2]	M8 180kg-cm [156.2 lb-in.] [17.65Nm]	
VFD2200C43A		95 mm <sup>2</sup> *4 [3/0AWG*4]		95 mm <sup>2</sup> *4 [3/0AWG*4]	95 mm <sup>2</sup> *2 [3/0AWG*2]		
VFD1850C43E		50 mm <sup>2</sup> *4 [1/0AWG*4]		50 mm <sup>2</sup> *4 [1/0AWG*4]	50 mm <sup>2</sup> *2 [1/0AWG*2]		
VFD2200C43E		70 mm <sup>2</sup> *4 [2/0AWG*4]		70 mm <sup>2</sup> *4 [2/0AWG*2]	70 mm <sup>2</sup> *2 [2/0AWG*2]		
VFD2500C63B-00	150mm <sup>2</sup> *4 [300MCM*4]	50 mm <sup>2</sup> *4 [1/0 AWG*4]		50 mm <sup>2</sup> *4 [1/0 AWG*4]	50 mm <sup>2</sup> *2 [1/0 AWG*2]		
VFD3150C63B-00							
VFD2500C63B-21							
VFD3150C63B-21							

Model Name	Main Circuit Terminals U/T1, V/T2, W/T3, +1/DC+, -/DC-			Terminal		
	Max. Wire Gauge	Min. Wire Gauge	Screw Spec. and Torque (±10%)	Max. Wire Gauge	Min. Wire Gauge	Screw Spec. and Torque (±10%)
VFD1850C43A	240mm <sup>2</sup> *2 [500MCM*2]	240 mm <sup>2</sup> *2 [400MCM*2]	M12 408kg-cm [354.1 lb-in.] [39.98 Nm]	240 mm <sup>2</sup> *2 [400MCM*2]	240 mm <sup>2</sup> *1 [400MCM*1]	M8 180kg-cm [156.2 lb-in.] [17.65Nm]
VFD2200C43A		240 mm <sup>2</sup> *2 [500MCM*2]		240 mm <sup>2</sup> *2 [500MCM*2]	240 mm <sup>2</sup> *1 [500MCM*1]	
VFD1850C43E		150 mm <sup>2</sup> *2 [300MCM*2]		150 mm <sup>2</sup> *2 [300MCM*2]	150 mm <sup>2</sup> *1 [300MCM*2]	
VFD2200C43E		240 mm <sup>2</sup> *2 [400MCM*2]		240 mm <sup>2</sup> *2 [400MCM*2]	240 mm <sup>2</sup> *1 [400MCM*1]	
VFD2500C63B-00		120 mm <sup>2</sup> *2 [250MCM*2]		120 mm <sup>2</sup> *2 [250MCM*2]	120 mm <sup>2</sup> *1 [250MCM*1]	
VFD3150C63B-00		150 mm <sup>2</sup> *2 [350MCM*2]		150 mm <sup>2</sup> *2 [350MCM*2]	150 mm <sup>2</sup> *1 [350MCM*1]	
VFD2500C63B-21		120 mm <sup>2</sup> *2 [250MCM*2]		120 mm <sup>2</sup> *2 [250MCM*2]	120 mm <sup>2</sup> *1 [250MCM*1]	
VFD3150C63B-21		150 mm <sup>2</sup> *2 [350MCM*2]		150 mm <sup>2</sup> *2 [350MCM*2]	150 mm <sup>2</sup> *1 [350MCM*1]	

**Frame H**

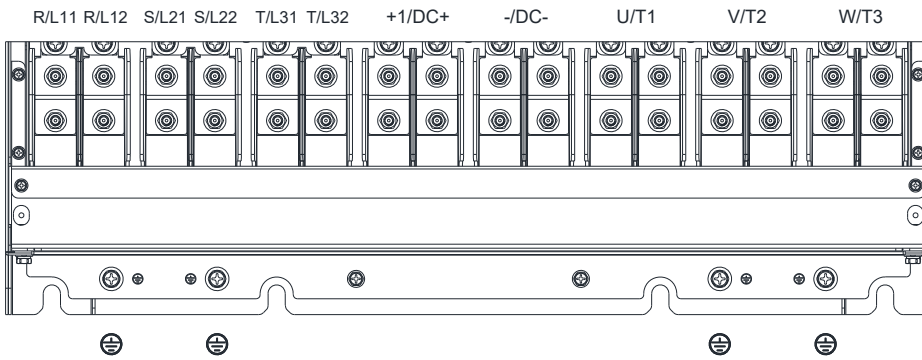

- If you install at Ta 50°C (for 230V / 460V model names with last digit A; for 690V model names end with 63B-00) / 40°C (for 230V / 460V model names with last digit A; for 690V model names end with 63B-21) environment, please select copper wire with voltage rating 600V and temperature resistant at 75°C or 90°C.
- If you install at Ta 50°C (for 230V / 460V model names with last digit A; for 690V model names end with 63B-00) / 40°C (for 230V / 460V model names with last digit A; for 690V model names end with 63B-21) above environment, please select copper wire with voltage rating 600V and temperature resistant at 90°C or above.
- For VFD4500C43A, VFD4500C43E-1, if you install at Ta 40°C above environment, please select copper wire with voltage rating 600V and temperature resistant at 90°C or above.
- For UL installation compliant, please use copper wires for installation, the wire gauge is based on temperature resistant at 75°C which is requested and recommended from UL. Do not reduce the wire gauge when using higher temperature wire.

Model Name	Main Circuit Terminals R/L11, R/L12, S/L21, S/L22, T/L31, T/L32, U/T1, V/T2, W/T3, +1/DC+, -/DC-			Terminal ⊕		
	Max. Wire Gauge	Min. Wire Gauge	Screw Spec. and Torque (±10%)	Max. Wire Gauge	Min. Wire Gauge	Screw Spec. and Torque (±10%)
VFD2800C43A	185mm <sup>2</sup> *4 [350MCM*4]	120 mm <sup>2</sup> *4 [4/0AWG*4]	M8 180kg-cm [156.2 lb-in.] [17.65Nm]	120 mm <sup>2</sup> *4 [4/0AWG*4]	120 mm <sup>2</sup> *2 [4/0AWG*2]	M8 180kg-cm [156.2 lb-in.] [17.65Nm]
VFD3150C43A		150 mm <sup>2</sup> *4 [300MCM*4]		150 mm <sup>2</sup> *4 [300MCM*4]	150 mm <sup>2</sup> *2 [300MCM*2]	
VFD3550C43A		185 mm <sup>2</sup> *4 [350MCM*4]		185 mm <sup>2</sup> *4 [350MCM*4]	185 mm <sup>2</sup> *2 [350MCM*2]	
VFD4500C43A		120 mm <sup>2</sup> *4 [4/0AGW*4]		120 mm <sup>2</sup> *4 [4/0AGW*4]	120 mm <sup>2</sup> *2 [4/0AGW*2]	
VFD2800C43E-1		150 mm <sup>2</sup> *4 [300MCM*4]		150 mm <sup>2</sup> *4 [300MCM*4]	150 mm <sup>2</sup> *2 [300MCM*2]	
VFD3150C43E-1		185 mm <sup>2</sup> *4 [350MCM*4]		185 mm <sup>2</sup> *4 [350MCM*4]	185 mm <sup>2</sup> *2 [350MCM*2]	
VFD3550C43E-1		95 mm <sup>2</sup> *4 [3/0AWG*4]		95 mm <sup>2</sup> *4 [3/0AWG*4]	95 mm <sup>2</sup> *2 [3/0AWG*2]	
VFD4500C43E-1		120 mm <sup>2</sup> *4 [4/0AGW*4]		120 mm <sup>2</sup> *4 [4/0AGW*4]	120 mm <sup>2</sup> *2 [4/0AGW*2]	
VFD2800C43E		120 mm <sup>2</sup> *4 [250MCM*4]		120 mm <sup>2</sup> *4 [250MCM*4]	120 mm <sup>2</sup> *2 [250MCM*2]	
VFD3150C43E		185 mm <sup>2</sup> *4 [350MCM*4]		185 mm <sup>2</sup> *4 [350MCM*4]	185 mm <sup>2</sup> *2 [350MCM*2]	
VFD3550C43E		95 mm <sup>2</sup> *4 [3/0AWG*4]		95 mm <sup>2</sup> *4 [3/0AWG*4]	95 mm <sup>2</sup> *2 [3/0AWG*2]	
VFD4500C43E		120 mm <sup>2</sup> *4 [250MCM*4]		120 mm <sup>2</sup> *4 [250MCM*4]	120 mm <sup>2</sup> *2 [250MCM*2]	
VFD4000C63B-00		150 mm <sup>2</sup> *4 [300MCM*4]		150 mm <sup>2</sup> *4 [300MCM*4]	150 mm <sup>2</sup> *2 [300MCM*2]	
VFD4500C63B-00		95 mm <sup>2</sup> *4 [3/0AWG*4]		95 mm <sup>2</sup> *4 [3/0AWG*4]	95 mm <sup>2</sup> *2 [3/0AWG*2]	
VFD5600C63B-00		120 mm <sup>2</sup> *4 [250MCM*4]		120 mm <sup>2</sup> *4 [250MCM*4]	120 mm <sup>2</sup> *2 [250MCM*2]	
VFD6300C63B-00		150 mm <sup>2</sup> *4 [300MCM*4]		150 mm <sup>2</sup> *4 [300MCM*4]	150 mm <sup>2</sup> *2 [300MCM*2]	
VFD4000C63B-21		95 mm <sup>2</sup> *4 [3/0AWG*4]		95 mm <sup>2</sup> *4 [3/0AWG*4]	95 mm <sup>2</sup> *2 [3/0AWG*2]	
VFD4500C63B-21		120 mm <sup>2</sup> *4 [250MCM*4]		120 mm <sup>2</sup> *4 [250MCM*4]	120 mm <sup>2</sup> *2 [250MCM*2]	
VFD5600C63B-21		150 mm <sup>2</sup> *4 [300MCM*4]		150 mm <sup>2</sup> *4 [300MCM*4]	150 mm <sup>2</sup> *2 [300MCM*2]	
VFD6300C63B-21						

[The page intentionally left blank]

# ***Chapter 6 Control Terminals***

---

6-1 Remove the Cover for Wiring

6-2 Specifications of Control Terminal

6-3 Remove the Terminal Block



**Analog input terminals (AVI, ACI, AUI, ACM)**

- ☑ Analog input signals are easily affected by external noise. Use shielded wiring and keep it as short as possible (<20m) with proper grounding. If the noise is inductive, connecting the shield to terminal ACM can bring improvement.
- ☑ When using analog input signal in the circuit, twisted pair is suggested to use for dealing with weak signal.
- ☑ If the analog input signals are affected by noise from the AC motor drive, please connect a capacitor and ferrite core as indicated in the following diagram.

Wind each wires 3 times or more around the core

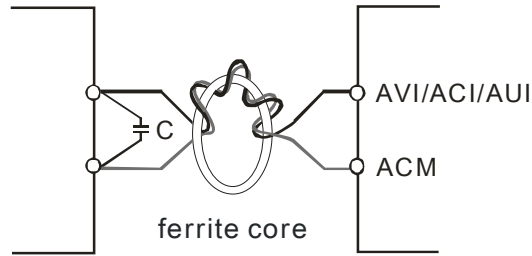

Figure 6-1

**Digital inputs (FWD, REV, MI1–MI8, COM)**

- ☑ The “COM” terminal is the common side of the photo-coupler. Any of wiring method, the “common point” of all photo-coupler must be the “COM”.

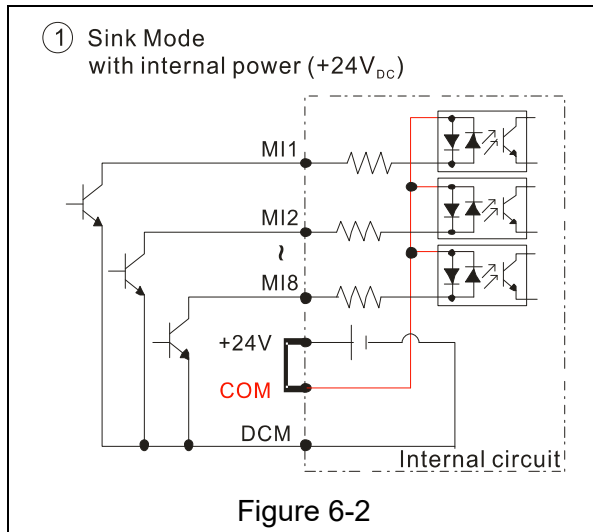

Figure 6-2

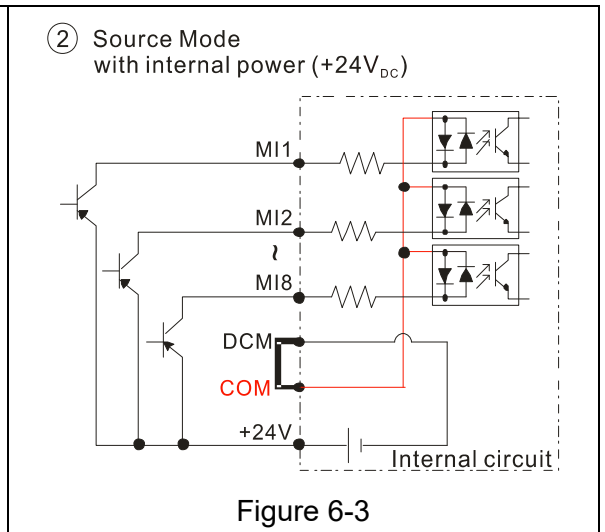

Figure 6-3

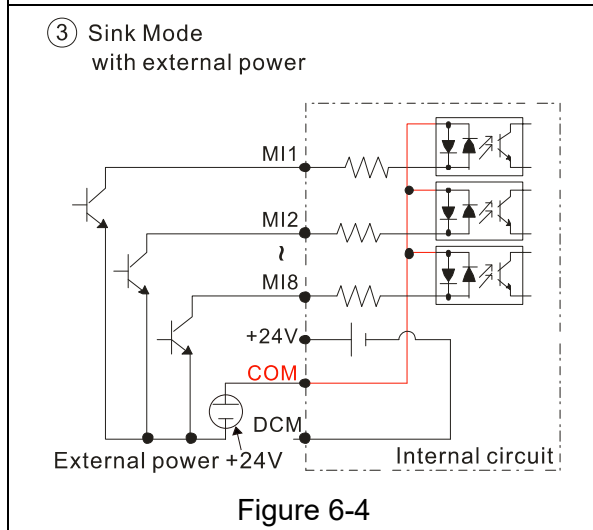

Figure 6-4

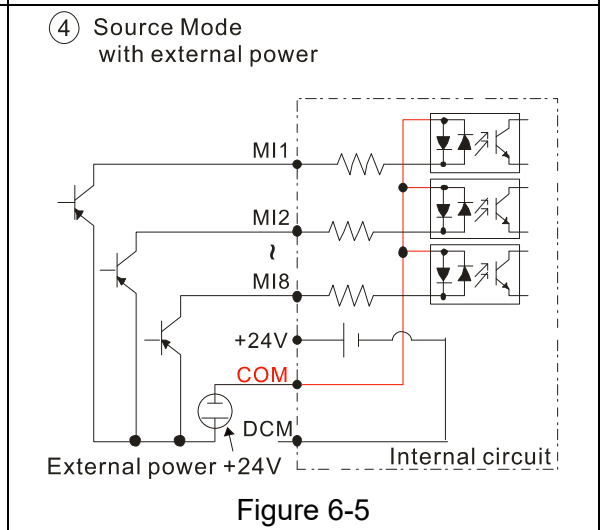

Figure 6-5

- ☑ When the photo-coupler is using internal power supply, the switch connection for Sink and Source as below:  
MI-DCM: Sink mode  
MI-+24V: Source mode
- ☑ When the photo-coupler is using external power supply, please remove the short circuit cable between the +24V and COM terminals. The connection mode is Sink mode or Source mode according to the below:  
The "+" of 24V connecting to "COM: Sink mode  
The "-" of 24V connecting to COM: Source mode

### **Transistor outputs (MO1, MO2, MCM)**

- ☑ Make sure to connect the digital outputs to the right polarity.
- ☑ When connecting a relay to the digital outputs connect a surge absorber across the coil and check the polarity.



## 6-1 Remove the Cover for Wiring

Please remove the top cover before wiring the multi-function input and output terminals.

 **NOTE** The drive appearances shown in the figures are for reference only, a real drive may look different.

### Frame A & B

Applicable models: VFD007C23A; VFD007C43A/E; VFD015C23A; VFD015C43A/E; VFD022C23A; VFD022C43A/E; VFD037C23A; VFD037C43A/E; VFD040C43A/E; VFD055C43A/E; VFD015C53A-21; VFD022C53A-21; VFD037C53A-21; VFD055C23A; VFD075C23A; VFD075C43A/E; VFD110C23A; VFD110C43A/E; VFD150C43A/E; VFD055C53A-21; VFD075C53A-21; VFD110C53A-21; VFD150C53A-21

Screw torque: 12–15 kg-cm / [10.4–13 lb-in.] / [1.2–1.5 Nm]

Loosen the screws and press the tabs on both sides to remove the cover.

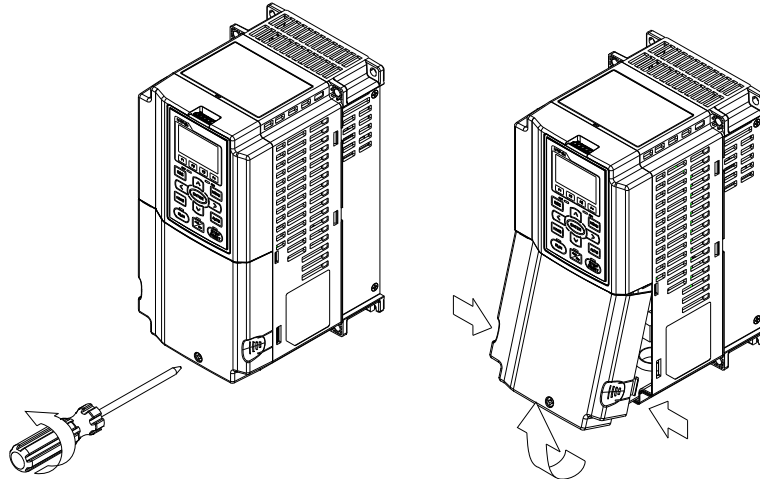

Figure 6-6

### Frame C

Applicable models: VFD150C23A; VFD185C23A; VFD185C43A/E; VFD220C23A; VFD220C43A/E; VFD300C43A/E; VFD185C63B-21; VFD220C63B-21; VFD300C63B-21; VFD370C63B-21

Screw torque: 12–15 kg-cm / [10.4–13 lb-in.] / [1.2–1.5 Nm]

Loosen the screws and press the tabs on both sides to remove the cover.

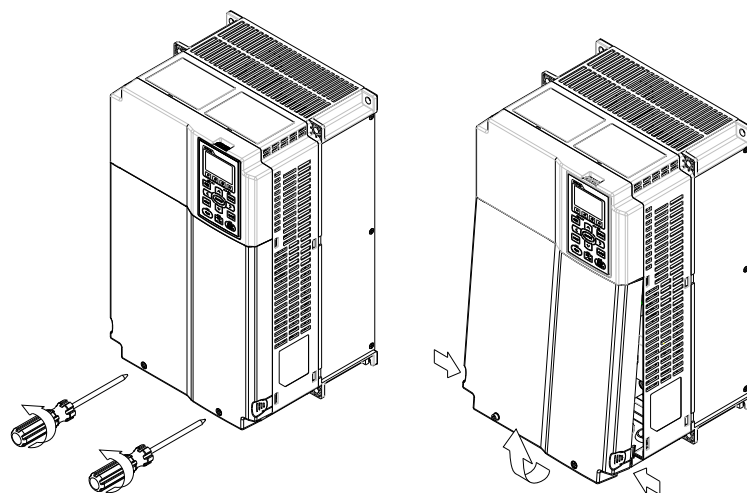

Figure 6-7

**Frame D0 & D**

Applicable models: VFD370C43S; VFD450C43S; VFD370C43U; VFD450C43U; VFD300C23A; VFD370C23A; VFD550C43A; VFD750C43A; VFD300C23E; VFD370C23E; VFD550C43E; VFD750C43E; VFD450C63B-00; VFD550C63B-00; VFD450C63B-21; VFD550C63B-21

Screw torque: 12–15 kg-cm / [10.4–13 lb-in.] / [1.2–1.5 Nm]

To remove the cover, lift it slightly and pull outward.

Loosen the screws and press the tabs on both sides to remove the cover.

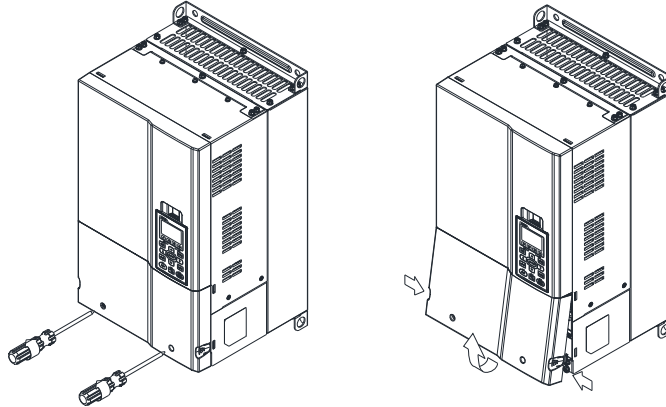

Figure 6-8

**Frame E**

Applicable models: VFD450C23A; VFD550C23A; VFD750C23A; VFD900C43A; VFD1100C43A; VFD450C23E; VFD550C23E; VFD750C23E; VFD900C43E; VFD1100C43E; VFD750C63B-00; VFD900C63B-00; VFD1100C63B-00; VFD1320C63B-00; VFD750C63B-21; VFD900C63B-21; VFD1100C63B-21; VFD1320C63B-21

Screw torque: 12–15 kg-cm / [10.4–13 lb-in.] / [1.2–1.5 Nm]

To remove the cover, lift it slightly and pull outward.

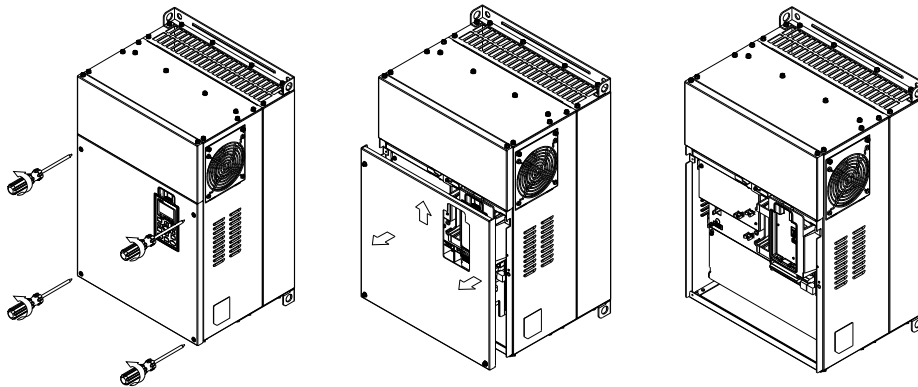

Figure 6-9

**Frame F**

Applicable models: VFD900C23A; VFD1320C43A; VFD1600C43A; VFD900C23E; VFD1320C43E; VFD1600C43E; VFD1600C63B-00; VFD2000C63B-00; VFD1600C63B-21; VFD2000C63B-21

Screw torque: 12–15 kg-cm / [10.4–13 lb-in.] / [1.2–1.5 Nm]

To remove the cover, lift it slightly and pull outward.

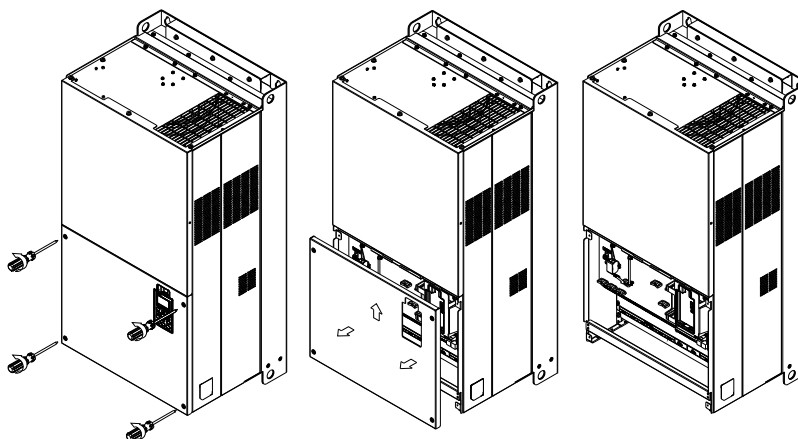

Figure 6-10

**Frame G**

Applicable models: VFD1850C43A; VFD2200C43A; VFD1850C43E; VFD2200C43E; VFD2500C63B-00; VFD3150C63B-00; VFD2500C63B-21; VFD3150C63B-21

Screw torque: 12–15 kg-cm / [10.4–13 lb-in.] / [1.2–1.5 Nm]

To remove the cover, lift it slightly and pull outward.

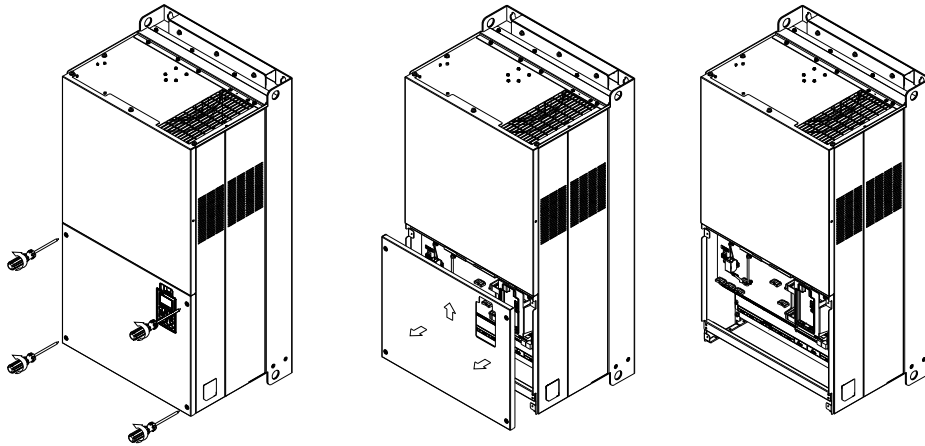

Figure 6-11

**Frame H**

Applicable models: VFD2800C43A; VFD3150C43A; VFD3550C43A; VFD4500C43A; VFD2800C43E-1; VFD3150C43E-1; VFD3550C43E-1; VFD4500C43E-1; VFD2800C43E; VFD3150C43E; VFD3550C43E; VFD4500C43E; VFD4000C63B-00; VFD4500C63B-00; VFD5600C63B-00; VFD6300C63B-00

Screw torque: 14–16 kg-cm / [12.15–13.89 lb-in.] / [1.4–1.6 Nm]

To remove the cover, lift it slightly and pull outward.

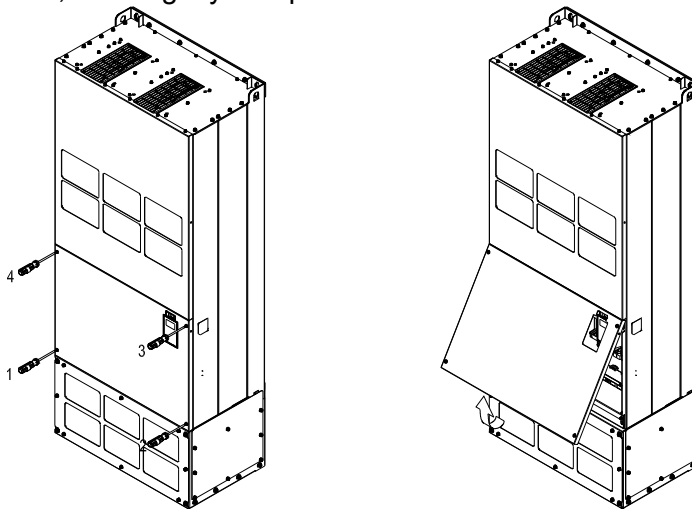

Figure 6-12

**690V Frame H3**

Applicable models: VFD4000C63B-21; VFD4500C63B-21; VFD5600C63B-21; VFD6300C63B-21

Screw torque: 14–16 kg-cm [12.15–13.89 lb-in.] [1.37–1.57 Nm]

To remove the cover, lift it slightly and pull outward.

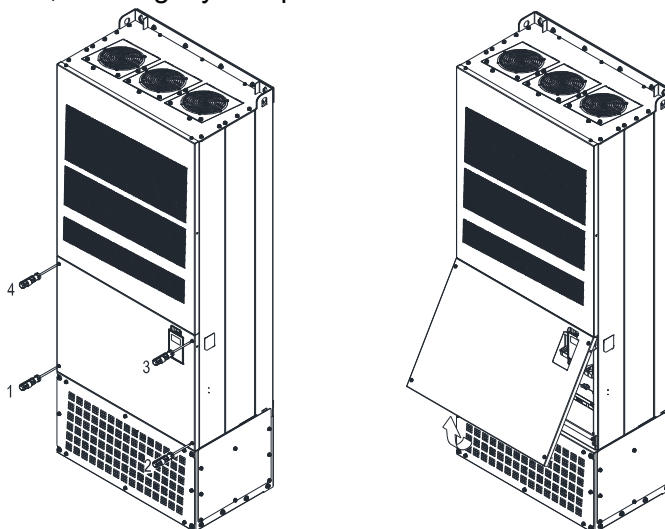

Figure 6-13

## 6-2 Specifications of Control Terminal

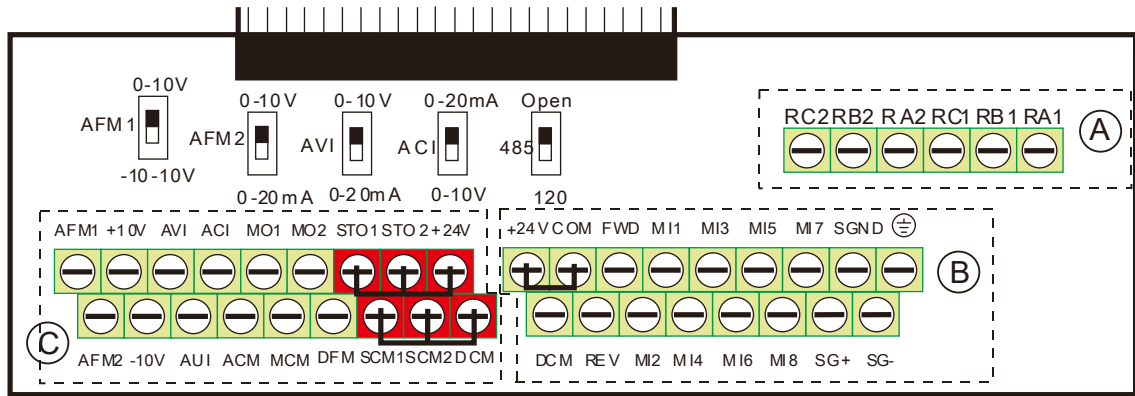

Figure 6-14. Removable Terminal Block

Function name	Area	Conductor	Stripping length (mm)	Maximum Wire Gauge	Minimum Wire Gauge	Tightening torque (±10)
RELAY Terminals	Ⓐ	Conductor cross section solid wire	4-5			5 kg-cm [4.3 lb-in.] [0.49 Nm]
		Conductor cross section stranded wire				
Control Terminals	Ⓑ	Conductor cross section solid wire	6-7	1.5 mm <sup>2</sup> [16 AWG]	0.2 mm <sup>2</sup> [26 AWG]	8 kg-cm [6.9 lb-in.] [0.78 Nm]
		Conductor cross section stranded wire				
Control Terminals	Ⓒ	Conductor cross section solid wire				2 kg-cm [1.7 lb-in.] [0.20 Nm]
		Conductor cross section stranded wire				

### Wiring precautions:

- In the figure above, the factory setting for STO1, STO2, +24V and SCM1, SCM2, DCM are short circuit. The +24V from section Ⓒ of above figure is for STO only, and cannot be used for other purposes. The factory setting for +24V-COM is short circuit and SINK mode (NPN); please refer to Chapter 4 Wiring for more detail.
- Tighten the wiring with slotted screwdriver:
  - Ⓐ Ⓑ is 3.5 mm (wide) x 0.6 mm (thick); Ⓒ is 2.5 mm (wide) x 0.4 mm (thick)
- When wiring bare wires, make sure they are perfectly arranged to go through the wiring holes.

Terminals	Terminal Function	Factory Setting (NPN mode)
+24V	Digital control signal common (Source)	+24V ± 5% 200 mA
COM	Digital control signal common (Sink)	Common for multi-function input terminals
FWD	Forward-Stop command	FWD-DCM: ON → forward running OFF → deceleration to stop
REV	Reverse-Stop command	REV-DCM: ON → reverse running OFF → deceleration to stop

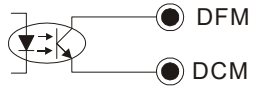
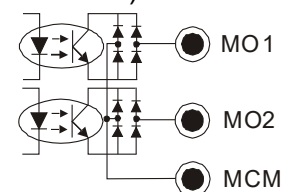
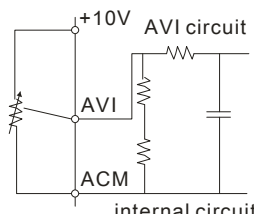
Terminals	Terminal Function	Factory Setting (NPN mode)	
MI1 – MI8	Multi-function input 1–8	Refer to parameters 02-01–02-08 to program the multi-function inputs MI1–MI8. <b>Source mode</b> ON: the activation current is 3.3 mA ≥ 11 V <sub>DC</sub> OFF: cut-off voltage ≤ 5 V <sub>DC</sub> <b>Sink Mode</b> ON: the activation current is 3.3 mA ≤ 13 V <sub>DC</sub> OFF: cut-off voltage ≥ 19 V <sub>DC</sub>	
DFM	Digital frequency meter  Figure 6-15	Regard the pulse voltage as the output monitor signal; Duty-cycle: 50 % Min. load impedance: 1 kΩ / 100 pf Max. current: 30 mA	
DCM	Digital frequency signal common	Max. voltage: 30 V <sub>DC</sub>	
MO1	Multi-function output 1 (photocoupler)	The AC motor drive releases various monitor signals, such as drive in operation, frequency attained and overload indication, via transistor (open collector).  Figure 6-16	
MO2	Multi-function output 2 (photocoupler)		
MCM	Multi-function output common	Max 48 V <sub>DC</sub> 50 mA	
RA1	Multi-function relay output 1 (N.O.) a	<b>Resistive Load</b> 3A (N.O.) / 3A (N.C.) 250 V <sub>AC</sub> 5A (N.O.) / 3A (N.C.) 30 V <sub>DC</sub> <b>Inductive Load (COS 0.4)</b> 1.2A (N.O.) / 1.2A (N.C.) 250 V <sub>AC</sub> 2.0A (N.O.) / 1.2A (N.C.) 30 V <sub>DC</sub> It is used to output each monitor signal, such as drive is in operation, frequency attained or overload indication.	
RB1	Multi-function relay output 1 (N.C.) b		
RC1	Multi-function relay common		
RA2	Multi-function relay output 2 (N.O.) a		
RB2	Multi-function relay output 2 (N.C.) b		
RC2	Multi-function relay common		
+10V	Potentiometer power supply		Analog frequency setting: +10V <sub>DC</sub> 20 mA
-10V	Potentiometer power supply		Analog frequency setting: -10V <sub>DC</sub> 20 mA
AVI	Analog voltage input  Figure 6-17	Impedance: 20 kΩ Range: 0–20 mA / 4–20 mA / 0–10 V = 0–Max. Output Frequency (Pr.01-00) AVI switch, factory setting is 0–10 V	

Terminals	Terminal Function	Factory Setting (NPN mode)
ACI	Analog current input  Figure 6-18	Impedance: 250Ω Range: 0–20mA / 4–20mA / 0–10V = 0–Max. Output Frequency (Pr. 01-00) ACI Switch, factory setting is 4–20mA
AUI	Auxiliary analog voltage input  Figure 6-19	Impedance: 20kΩ Range: -10+10V <sub>DC</sub> =0–Max. Output Frequency (Pr. 01-00)
AFM1	Multi-function analog voltage output  Figure 6-20	0–10V Max. output current 2mA, Max. load 5kΩ -10–10V maximum output current 2mA, maximum load 5kΩ Output current: 2mA max Resolution: 0–10V corresponds to Max. operation frequency Range: 0–10V → -10+10V AFM1 Switch, factory setting is 0–10V
AFM2		0–10V Max. output current 2mA, Max. load 5kΩ 0–20mA Max. load 500Ω Output current: 20mA max Resolution: 0–10V corresponds to Max. operation frequency Range: 0–10V → 4–20mA AFM2 Switch, factory setting is 0–10V
ACM	Analog signal common	Common for analog terminals
STO1	Default setting is shorted	
SCM1	Power removal safety function for EN954-1 and IEC/EN61508	
STO2	When STO1–SCM1; STO2–SCM2 is activated, the activation current is 3.3mA ≥ 11V <sub>DC</sub>	
SCM2	Note: Please refer to CH 17 Safe Torque off Function.	
SG+	MODBUS RS-485	
SG-	Note: Please refer to CH12 DESCRIPTION OF PARAMETER SETTINGS group 09	
SGND	Communication Parameters for more information.	
RJ-45	PIN 1, 2, 7, 8: Reserved PIN 4: SG-	PIN 3, 6: SGND PIN 5: SG+

Table 6-1

NOTE: Wire size of analog control signals: 0.75 mm<sup>2</sup> [18 AWG] with shielded wire

### 6-3 Remove the Terminal Block

1. Loosen the screws by screwdriver. (As shown in figure below).

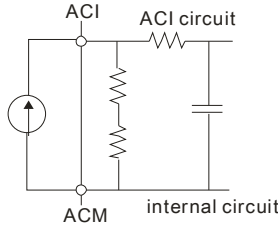
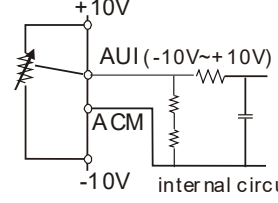
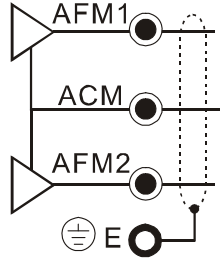
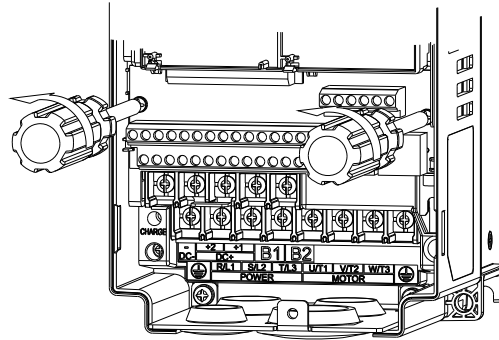

Figure 6-21

2. Remove the control board by pulling it out for a distance 6–8 cm (as 1 in the figure) then lift the control board upward (as 2 in the figure).

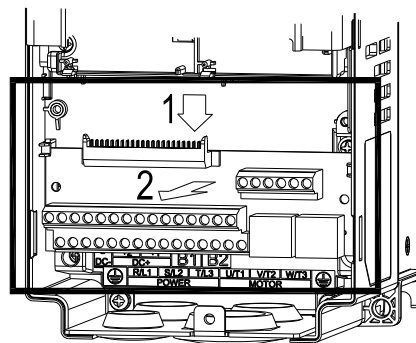

Figure 6-22

# Chapter 7 Optional Accessories

---

- 7-1 All Brake Resistors and Brake Units Used in AC Motor Drives
- 7-2 Non-fuse Circuit Breaker
- 7-3 Fuse Specification Chart
- 7-4 AC / DC Reactor
- 7-5 Zero Phase Reactors
- 7-6 EMC Filter
- 7-7 Panel Mounting (MKC-KPPK)
- 7-8 Conduit Box Kit
- 7-9 Fan Kit
- 7-10 Flange Mounting Kit
- 7-11 Power Terminal Kit
- 7-12 USB / RS-485 Communication Interface IFD6530



The optional accessories listed in this chapter are available upon request. Installing additional accessories to your drive would substantially improve the drive's performance. Please select an applicable accessory according to your need or contact the local distributor for suggestion.

### 7-1 All Brake Resistors and Brake Units Used in AC Motor Drives

#### 230V

Applicable Motor		*1 125% Braking Torque 10% ED					*2 Max. Braking Torque			
HP	kW	Braking Torque [kg-m]	Brake Unit *4VFDB	*3Braking Resistor-for each Brake Unit	Resistor value spec. for each AC motor Drive	Total Braking Current [A]	Min. Resistor Value [Ω]	Max. Total Braking Current [A]	Peak Power [kW]	
1	0.7	0.5	-	BR080W200*1	80W 200Ω	1.9	63.3	6	2.3	
2	1.5	1.0	-	BR200W091*1	200W 91Ω	4.2	47.5	8	3.0	
3	2.2	1.5	-	BR300W070*1	300W 70Ω	5.4	38.0	10	3.8	
5	3.7	2.5	-	BR400W040*1	400W 40Ω	9.5	19.0	20	7.6	
7.5	5.5	3.7	-	BR1K0W020*1	1000W 20Ω	19	14.6	26	9.9	
10	7.5	5.1	-	BR1K0W020*1	1000W 20Ω	19	14.6	26	9.9	
15	11	7.5	-	BR1K5W013*1	1500W 13Ω	29	12.6	29	10.6	
20	15	10.2	-	BR1K0W4P3*2	2 series	2000W 8.6Ω	44	8.3	46	17.5
25	18	12.2	-	BR1K0W4P3*2	2 series	2000W 8.6Ω	44	8.3	46	17.5
30	22	14.9	-	BR1K5W3P3*2	2 series	3000W 6.6Ω	58	5.8	66	25.1
40	30	20.3	2015*2	BR1K0W5P1*2	2 series	4000W 5.1Ω	75	4.8	80	30.4
50	37	25.1	2022*2	BR1K2W3P9*2	2 series	4800W 3.9Ω	97	3.2	120	45.6
60	45	30.5	2022*2	BR1K5W3P3*2	2 series	6000W 3.3Ω	118	3.2	120	45.6
75	55	37.2	2022*3	BR1K2W3P9*2	2 series	7200W 2.6Ω	145	2.1	180	68.4
100	75	50.8	2022*4	BR1K2W3P9*2	2 series	9600W 2Ω	190	1.6	240	91.2
125	90	60.9	2022*4	BR1K5W3P3*2	2 series	12000W 1.65Ω	230	1.6	240	91.2

Table 7-1

#### 460V

Applicable Motor		*1 125% Braking Torque 10% ED					*2 Max. Braking Torque			
HP	kW	Braking Torque [kg-m]	Brake Unit *4VFDB	*3Braking Resistor for each Brake Unit	Resistor value spec. for each AC motor Drive	Total Braking Current [A]	Min. Resistor Value [Ω]	Max. Total Braking Current [A]	Peak Power [kW]	
1	0.7	0.5	-	BR080W750*1	80W 750Ω	1	190.0	4	3.0	
2	1.5	1.0	-	BR200W360*1	200W 360Ω	2.1	126.7	6	4.6	
3	2.2	1.5	-	BR300W250*1	300W 250Ω	3	108.6	7	5.3	
5	3.7	2.5	-	BR400W150*1	400W 150Ω	5.1	84.4	9	6.8	
5.5	4.0	2.7	-	BR1K0W075*1	1000W 75Ω	10.2	54.3	14	10.6	
7.5	5.5	3.7	-							
10	7.5	5.1	-	BR1K0W075*1	1000W 75Ω	10.2	47.5	16	12.2	
15	11	7.5	-	BR1K5W043*1	1500W 43Ω	17.6	42.2	18	13.7	
20	15	10.2	-	BR1K0W016*2	2 series	2000W 32Ω	24	26.2	29	22.0
25	18	12.2	-	BR1K0W016*2	2 series	2000W 32Ω	24	23.0	33	25.1
30	22	14.9	-	BR1K5W013*2	2 series	3000W 26Ω	29	23.0	33	25.1
40	30	20.3	-	BR1K0W016*4	2 parallel, 2 series	4000W 16Ω	47.5	14.1	54	41.0
50	37	25.1	4045*1	BR1K2W015*4	2 parallel, 2 series	4800W 15Ω	50	12.7	60	45.6
60	45	30.5	4045*1	BR1K5W013*4	2 parallel, 2 series	6000W 13Ω	59	12.7	60	45.6
75	55	37.2	4030*2	BR1K0W5P1*4	4 series	8000W 10.2Ω	76	9.5	80	60.8
100	75	50.8	4045*2	BR1K2W015*4	2 parallel, 2 series	9600W 7.5Ω	100	6.3	120	91.2
125	90	60.9	4045*2	BR1K5W013*4	2 parallel, 2 series	12000W 6.5Ω	117	6.3	120	91.2
150	110	74.5	4110*1	BR1K2W015*10	5 parallel, 2 series	12000W 6Ω	126	6.0	126	95.8
175	132	89.4	4160*1	BR1K5W012*12	6 parallel, 2 series	18000W 4Ω	190	4.0	190	144.4
215	160	108.3	4160*1	BR1K5W012*12	6 parallel, 2 series	18000W 4Ω	190	4.0	190	144.4
250	185	125.3	4185*1	BR1K5W012*14	7 parallel, 2 series	21000W 3.4Ω	225	3.4	225	172.1

Applicable Motor		*1 125% Braking Torque 10% ED						*2 Max. Braking Torque		
HP	kW	Braking Torque [kg-m]	Brake Unit *4VFDB	*3Braking Resistor for each Brake Unit		Resistor value spec. for each AC motor Drive	Total Braking Current [A]	Min. Resistor Value [Ω]	Max. Total Braking Current [A]	Peak Power [kW]
				300	220					
375	280	189.6	4160*2	BR1K5W012*12	6 parallel, 2 series	36000W 2Ω	380	2.0	380	288.8
425	315	213.3	4160*2	BR1K5W012*12	6 parallel, 2 series	36000W 2Ω	380	2.0	380	288.8
475	355	240.3	4185*2	BR1K5W012*14	7 parallel, 2 series	42000W 1.7Ω	450	1.7	450	344.2
600	450	304.7	4185*3	BR1K5W012*12	6 parallel, 2 series	54000W 1.3Ω	600	1.1	675	513.0

Table 7-2

## 575V

Applicable Motor (kW)			* 1 125% Braking Torque / 10%ED					* 2 Max. Braking Torque			
LD	ND	HD	Braking Torque [kg-m]	Brake Unit VFDB	* 3 Braking Resistor for each Brake Unit	Resistor value spec. for each AC motor drive	Total Braking Current [A]	Min. Resistor Value [Ω]	Max. Total Braking Current [A]	Peak Power [kW]	
1.5	0.75	0.75	0.5	-	BR080W750*1	80W 750Ω	1.2	280.0	4	4.5	
2.2	1.5	1.5	1	-	BR200W360*1	200W 360Ω	2.6	186.7	6	6.7	
3.7	2.2	2.2	1.5	-	BR300W400*1	300W 400Ω	2.3	160.0	7	7.8	
5.5	3.7	3.7	2.5	-	BR500W100*1	500W 100Ω	9.2	93.3	12	13.4	
7.5	5.5	3.7	3.7	-	BR750W140*1	750W 140Ω	6.6	80.0	14	15.7	
11	7.5	7.5	5.1	-	BR1K0W075*1	1000W 75Ω	12.3	70.0	16	17.9	
15	11	7.5	7.4	-	BR1K1W091*1	1100W 91Ω	10.1	62.2	18	20.2	

Table 7-3

## 690V

Applicable Motor (kW)			* 1 125% Braking Torque / 10%ED					* 2 Max. Braking Torque			
LD	ND	HD	Braking Torque [kg-m]	Brake Unit VFDB	* 3 Braking Resistor series for each Brake Unit	Resistor value spec. for each AC motor drive	Total Braking Current [A]	Min. Resistor Value [Ω]	Max. Total Braking Current [A]	Peak Power [kW]	
18.5	15	11	10.2	-	BR1K0W039*2	2 series	2000W 78Ω	14.4	58.9	19	21.3
22	18.5	15	12.5	-	BR1K2W033*2	2 series	2400W 66Ω	17.0	58.9	19	21.3
30	22	18.5	14.9	-	BR1K5W027*2	2 series	3000W 54Ω	20.7	43.1	26	29.1
37	30	22	20.3	-	BR1K2W015*3	3 series	3600W 45Ω	24.9	43.1	26	29.1
45	37	30	25	6055*1	BR1K2W033*4	2 series, 2 parallel	4800W 33Ω	33.9	24.3	46	51.5
55	45	37	30.5	6055*1	BR1K5W027*4	2 series, 2 parallel	6000W 27Ω	41.5	24.3	46	51.5
75	55	45	37.2	6110*1	BR1K2W033*6	2 series, 3 parallel	7200W 22Ω	50.9	12.2	92	103.0
90	75	55	50.8	6110*1	BR1K5W027*6	2 series, 3 parallel	9000W 18Ω	62.2	12.2	92	103.0
110	90	75	60.9	6110*1	BR1K5W027*8	2 series, 4 parallel	12000W 13.5Ω	83.0	12.2	92	103.0
132	110	90	74.5	6160*1	BR1K2W015*12	3 series, 4 parallel	14400W 11.3Ω	99.6	8.2	136	152.3
160	132	110	89.4	6160*1	BR1K5W027*10	2 series, 5 parallel	15000W 10.8Ω	103.7	8.2	136	152.3
200	160	132	108.3	6200*1	BR1K5W027*12	2 series, 6 parallel	18000W 9.0Ω	124.4	6.9	162	181.4
250	200	160	135.4	6110*2	BR1K5W027*8	2 series, 4 parallel	24000W 6.8Ω	165.9	6.1	184	206.1
315	250	200	169.3	6160*2	BR1K5W027*10	2 series, 5 parallel	30000W 5.4Ω	207.4	4.1	272	304.6
400	315	250	213.3	6200*2	BR1K5W027*12	2 series, 6 parallel	36000W 4.5Ω	248.9	3.5	324	362.9

Applicable Motor (kW)			* 1 125% Braking Torque / 10%ED					* 2 Max. Braking Torque			
LD	ND	HD	Braking Torque [kg-m]	Brake Unit VFDB	* 3 Braking Resistor series for each Brake Unit		Resistor value spec. for each AC motor drive	Total Braking Current [A]	Min. Resistor Value [Ω]	Max. Total Braking Current [A]	Peak Power [kW]
450	355	315	240.3	6200*2	BR1K5W027*14	2 series, 7 parallel	42000W 3.9Ω	290.4	3.5	324	362.9
560	450	355	304.7	6200*3	BR1K5W027*12	2 series, 6 parallel	54000W 3.0Ω	373.3	2.3	486	544.3
630	630	630	426.5	6200*4	BR1K5W027*12	2 series, 6 parallel	72000W 2.3Ω	497.8	1.7	648	725.8

Table 7-4

- \*1. Calculation for 125% brake torque: (kW) \* 125% \* 0.8; where 0.8 is motor efficiency. Because of the limited resistor power, the longest operation time for 10% ED is 10 seconds (on: 10 seconds / off: 90 seconds).
- \*2. Refer to Chapter 7 “Brake Module and Brake Resistors” in application manual for “Operation Duration & ED” vs. “Braking Current”.
- \*3. For heat dissipation, a resistor of 400W or lower should be fixed to the frame and maintain the surface temperature below 250°C; a resistor of 1000W and above should maintain the surface temperature below 350°C.
- \*4. Please refer to VFDB series Braking Module Instruction for more detail on braking resistor.

**NOTE**

1. Specification and appearance of brake resistors

1-1 Wirewound resistor: for 1000W and above. Refer to the following appearance of wirewound resistor (Figure7-1) and its model and specification comparison table (Table 7-5) for details.

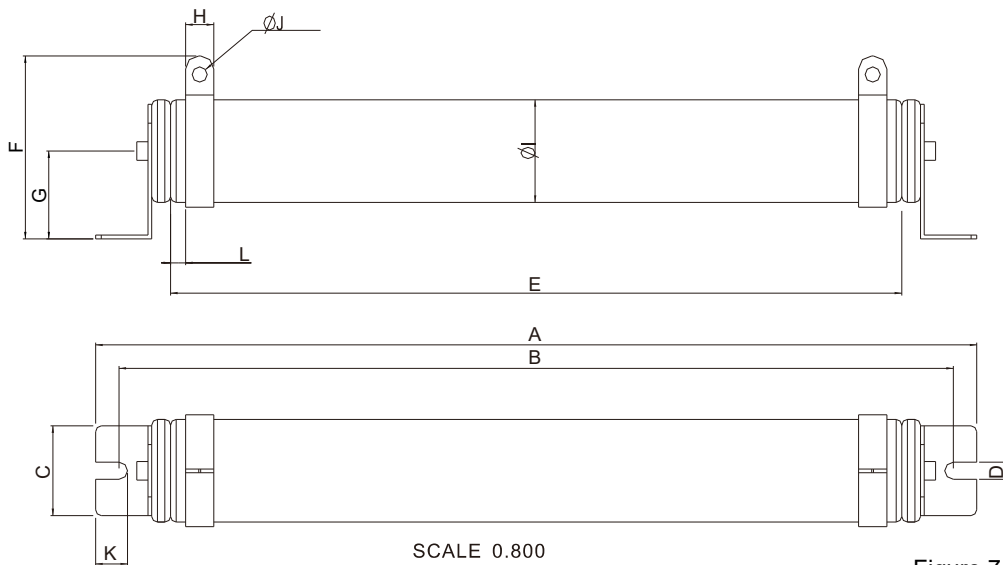

Figure 7-1

SCALE 0.800

UNIT: MM

MODEL	A	B	C	D	E	F	G	H	ØI	ØJ	K	L
BR1K0W4P3												
BR1K0W5P1												
BR1K0W016												
BR1K0W020												
BR1K0W075												
BR1K2W3P9	470±10	445±5	48±0.2	9.1±0.1	390±3	98±5	47±5	15±1	55±5	8.1±0.1	21±0.2	8±1
BR1K2W015												
BR1K5W3P3												
BR1K5W012												
BR1K5W013												
BR1K5W043												

Table 7-5

1-2 Aluminum housed resistor: for below 1000W. Refer to the following appearance of aluminum-housed resistor (Figure 7-2) and its model and specification comparison table (Table 7-6) for details.

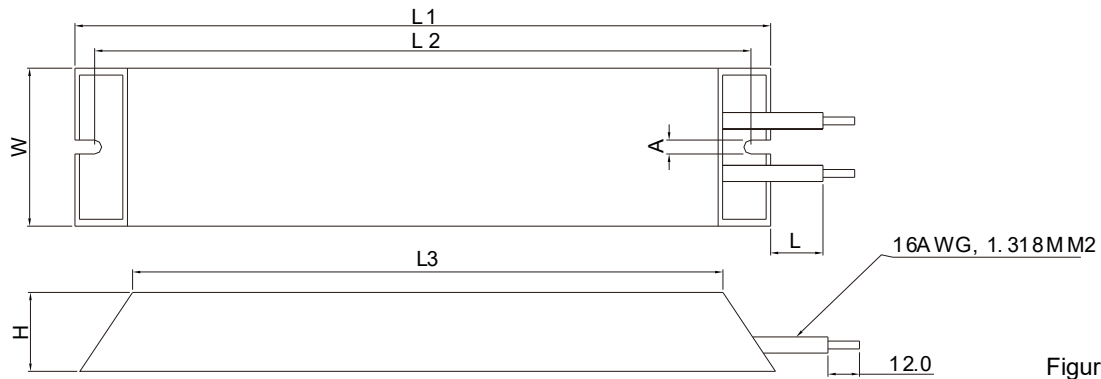

Figure 7-2

UNIT: MM

MODEL	L1	L2	L3	W	H	A	L				
BR080W200	140±2	125±2	100±1	40±0.5	20±0.5	5.3±0.5	200±20				
BR080W750											
BR200W091	165±2	150±2	125±1	60±0.5	30±0.5						
BR200W360											
BR300W070	215±2	200±2	175±1					60±0.5	30±0.5		
BR300W250											
BR400W040	265±2	250±2	225±1							60±0.5	30±0.5
BR400W150											

Table 7-6

2. Select the resistance value, power and brake usage (ED %) according to Delta rules.

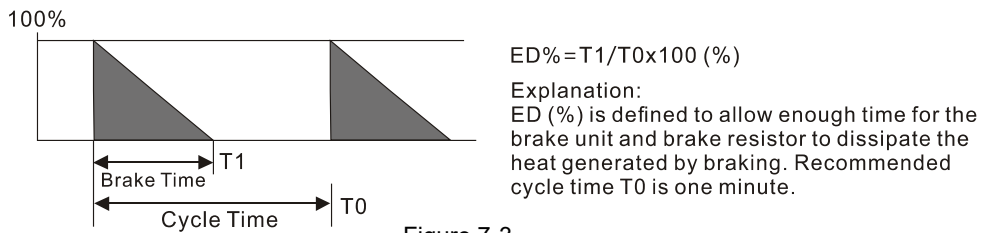

Figure 7-3

For safety, install a thermal overload relay (O.L) between the brake unit and the brake resistor in conjunction with the magnetic contactor (MC) before the drive for additional protection. The thermal overload relay protects the brake resistor from damage due to frequent or continuous braking. Under such circumstances, turn off the power to prevent damage to the brake resistor, brake unit and drive.

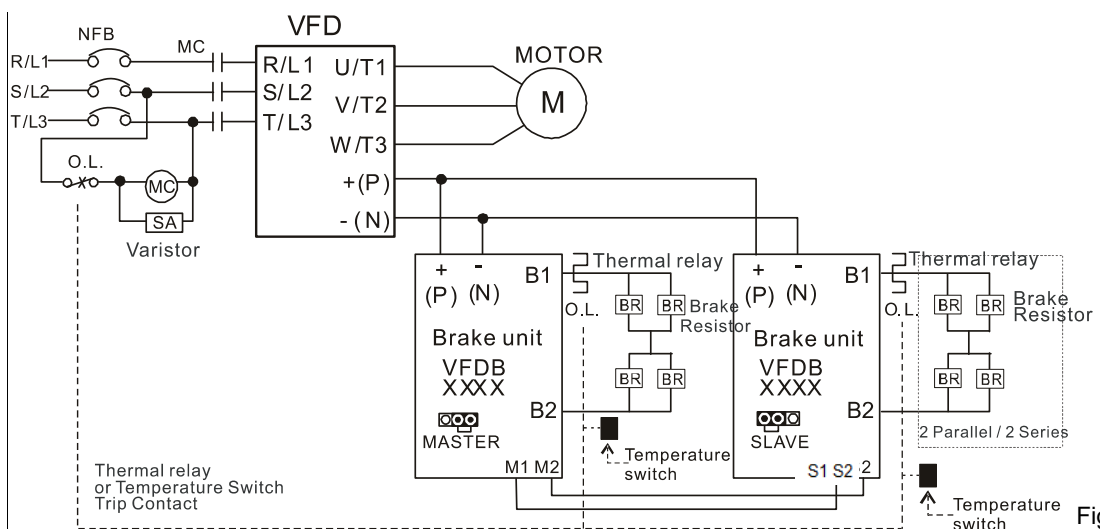

Figure 7-4

- When AC Drive is equipped with a DC reactor, please read user manual for the correct wiring for the brake unit input circuit +(P).
- DO NOT connect input circuit -(N) to the neutral point of the power system.

3. Any damage to the drive or other equipment caused by using brake resistors and brake modules that are not provided by Delta voids the warranty.
4. Consider environmental safety factors when installing the brake resistors. If you use the minimum resistance value, consult local dealers for the power calculation.
5. When using more than two brake units, the equivalent resistor value of the parallel brake unit cannot be less than the value in the column "Minimum Resistor Value ( $\Omega$ )". Read the wiring information in the brake unit user manual thoroughly prior to operation.
6. This chart is for normal usage; if the AC motor drive is applied for frequent braking, it is suggested to enlarge 2~3 times of the Watts.
7. Thermal Overload Relay (TOR), for 230V / 460V / 690V models: Choosing a thermal overload relay is based on whether its overload capacity is appropriate for the C2000. The standard braking capacity of the C2000 is 10% ED (Tripping time=10 s). As shown in the figure below, the thermal overload relay continuously operates for 10 seconds and it can withstand a 260% overload (Host starting). For example, a 460V, 110 kW C2000 has a braking current of 126 A (refer to the tables in this section), so it can use the thermal overload relay with a rated current of 50 A. The property of each thermal relay may vary among different manufacturer, please carefully read specification.

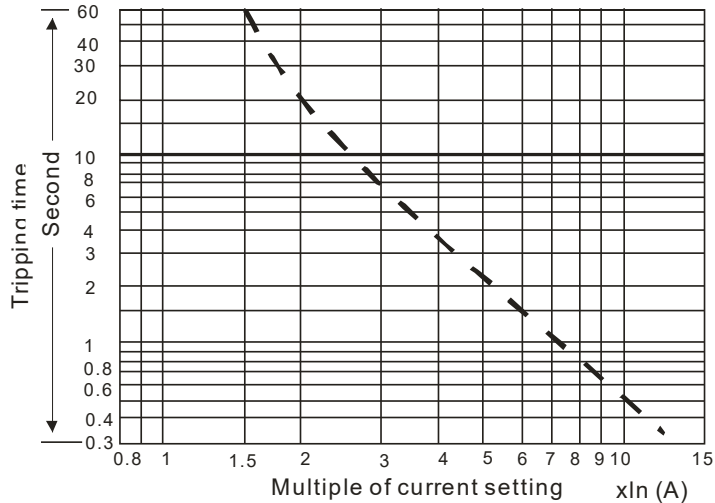

Figure 7-5

## 7-2 Non-fuse Circuit Breaker

Comply with UL standard: Per UL 508, paragraph 45.8.4, part a.

The rated current of the breaker shall be 1.6~2.6 times (575V / 690V models: 2~4 times) of the maximum rated input current of AC motor drive.

3-phase 230V	
Model	Recommended non-fuse breaker [A]
VFD007C23A	15
VFD015C23A	20
VFD022C23A	30
VFD037C23A	40
VFD055C23A	50
VFD075C23A	60
VFD110C23A	100
VFD150C23A	125
VFD185C23A	150
VFD220C23A	200
VFD300C23A/E	225
VFD370C23A/E	250
VFD450C23A/E	300
VFD550C23A/E	400
VFD750C23A/E	450
VFD900C23A/E	600

Table 7-7

3-phase 460V	
Model	Recommended non-fuse breaker [A]
VFD007C43A/E	5
VFD015C43A/E	10
VFD022C43A/E	15
VFD040C43A/E	20
VFD037C43A/E	20
VFD055C43A/E	30
VFD075C43A/E	40
VFD110C43A/E	50
VFD150C43A/E	60
VFD185C43A/E	75
VFD220C43A/E	100
VFD300C43A/E	125
VFD370C43S/U	150
VFD450C43S/U	175
VFD550C43A/E	250
VFD750C43A/E	300
VFD900C43A/E	300
VFD1100C43A/E	400
VFD1320C43A/E	500
VFD1600C43A/E	600
VFD1850C43A/E	600
VFD2200C43A/E	800
VFD2800C43A/E	1000
VFD3150C43A/E	1200
VFD3550C43A/E	1350
VFD4500C43A/E	1467

Table 7-8

3-phase 575V	
Model	Recommended non-fuse breaker [A]
VFD015C53A-21	5
VFD022C53A-21	10
VFD037C53A-21	15
VFD055C53A-21	20
VFD075C53A-21	25
VFD110C53A-21	40
VFD150C53A-21	50

Table 7-9

3-phase 690V	
Model	Recommended non-fuse breaker [A]
VFD185C63B-21	50
VFD220C63B-21	60
VFD300C63B-21	60
VFD370C63B-21	80
VFD450C63B-00 / 63B-21	100
VFD550C63B-00 / 63B-21	125
VFD750C63B-00 / 63B-21	150
VFD900C63B-00 / 63B-21	200
VFD1100C63B-00 / 63B-21	225
VFD1320C63B-00 / 63B-21	300
VFD1600C63B-00 / 63B-21	350
VFD2000C63B-00 / 63B-21	400
VFD2500C63B-00 / 63B-21	500
VFD3150C63B-00 / 63B-21	650
VFD4000C63B-00 / 63B-21	800
VFD4500C63B-00 / 63B-21	850
VFD5600C63B-00 / 63B-21	1200
VFD6300C63B-00 / 63B-21	1400

Table 7-10

## 7-3 Fuse Specification Chart

- ☑ Fuse specifications lower than the table below are allowed.
- ☑ For installation in the United States, branch circuit protection must be provided in accordance with the National Electrical Code (NEC) and any applicable local codes. Use UL classified fuses to fulfill this requirement.
- ☑ For installation in Canada, branch circuit protection must be provided in accordance with Canadian Electrical Code and any applicable provincial codes. Use UL classified fuses to fulfill this requirement.

230V Model	Input Current I [A]		Line Fuse	
	Heavy Duty	Normal Duty	I [A]	Bussmann P/N
VFD007C23A	6.1	6.4	15	JJN-15 / JJS-15
VFD015C23A	11	12	25	JJN-25 / JJS-25
VFD022C23A	15	16	35	JJN-35 / JJS-35
VFD037C23A	18.5	20	45	JJN-45 / JJS-45
VFD055C23A	26	28	60	JJN-60 / JJS-60
VFD075C23A	34	36	80	JJN-80 / JJS-80
VFD110C23A	50	52	110	JJN-110 / JJS-110
VFD150C23A	68	72	150	JJN-150 / JJS-150
VFD185C23A	78	83	175	JJN-175 / JJS-175
VFD220C23A	95	99	225	JJN-225 / JJS-225
VFD300C23A/E	118	124	250	JJN-250 / JJS-250
VFD370C23A/E	136	143	300	JJN-300 / JJS-300
VFD450C23A/E	162	171	400	JJN-400 / JJS-400
VFD550C23A/E	196	206	450	JJN-450 / JJS-450
VFD750C23A/E	233	245	500	JJN-500 / JJS-500
VFD900C23A/E	315	331	700	JJN-700 / JJS-700

Table 7-11

460V Model	Input Current I [A]		Line Fuse	
	Heavy Duty	Normal Duty	I [A]	Bussmann P/N
VFD007C43A/E	4.1	4.3	10	JJS-10
VFD015C43A/E	5.6	5.9	15	JJS-15
VFD022C43A/E	8.3	8.7	20	JJS-20
VFD037C43A/E	13	14	30	JJS-30
VFD040C43A/E	14.5	15.5	35	JJS-35
VFD055C43A/E	16	17	40	JJS-40
VFD075C43A/E	19	20	45	JJS-45
VFD110C43A/E	25	26	60	JJS-60
VFD150C43A/E	33	35	80	JJS-80
VFD185C43A/E	38	40	90	JJS-90
VFD220C43A/E	45	47	110	JJS-110
VFD300C43A/E	60	63	150	JJS-150
VFD370C43/S/U	70	74	175	JJS-175
VFD450C43/S/U	96	101	225	JJS-225
VFD550C43A/E	108	114	250	JJS-250
VFD750C43A/E	149	157	350	JJS-350
VFD900C43A/E	159	167	350	JJN-350
VFD1100C43A/E	197	207	450	JJS-450
VFD1320C43A/E	228	240	500	JJS-500
VFD1600C43A/E	285	300	700	KTU-700
VFD1850C43A/E	361	380	800	KTU-800
VFD2200C43A/E	380	400	800	KTU-800
VFD2800C43A/E	469	494	1000	KTU-1000
VFD3150C43A/E	527	555	1200	KTU-1200
VFD3550C43A/E	594	625	1400	KTU-1400
VFD4500C43A/E	815	866	1600	170M6019

Table 7-12

575V Model	Input Current I [A]			Line Fuse		
	Light Duty	Normal Duty	Heavy Duty	I [A]	Model No.	Supplier
VFD015C53A-21	3.8	3.1	2.6	7	KLKD007.T	Littelfuse
VFD022C53A-21	5.4	4.5	3.8	10	KLKD010.T	Littelfuse
VFD037C53A-21	10.4	7.2	5.8	15	KLKD015.T	Littelfuse
VFD055C53A-21	14.9	12.3	10.7	25	25ET	Busmann
VFD075C53A-21	16.9	15	12.5	32	32ET	Busmann
VFD110C53A-21	21.3	18	16.9	50	50FE	Busmann
VFD150C53A-21	26.3	22.8	19.7	63	63FE	Busmann

Table 7-13

690V Model	Input Current I [A]			Line Fuse	
	Light Duty	Normal Duty	Heavy Duty	I [A]	Busmann P/N
VFD185C63B-21	29	24	20	60	JJS-60
VFD220C63B-21	36	29	24	70	JJS-70
VFD300C63B-21	43	36	29	80	JJS-80
VFD370C63B-21	54	43	36	100	JJS-100
VFD450C63B-00 / 63B-21	54	45	36	100	JJS-100
VFD550C63B-00 / 63B-21	67	54	45	125	JJS-125
VFD750C63B-00 / 63B-21	84	66	53	175	JJS-175
VFD900C63B-00 / 63B-21	102	84	66	200	JJS-200
VFD1100C63B-00 / 63B-21	122	102	84	250	JJS-250
VFD1320C63B-00 / 63B-21	147	122	102	300	JJS-300
VFD1600C63B-00 / 63B-21	178	148	123	350	JJS-350
VFD2000C63B-00 / 63B-21	217	178	148	400	JJS-400
VFD2500C63B-00 / 63B-21	292	222	181	450	170M4063
VFD3150C63B-00 / 63B-21	353	292	222	500	170M6058
VFD4000C63B-00 / 63B-21	454	353	292	700	170M6061
VFD4500C63B-00 / 63B-21	469	388	313	800	170M6062
VFD5600C63B-00 / 63B-21	595	504	423	1250	170M6066
VFD6300C63B-00 / 63B-21	681	681	681	1400	170M6067

Table 7-14



## 7-4 AC / DC Reactor

### AC Input Reactor

Installing an AC reactor on the input side of an AC motor drive can increase line impedance, improve the power factor, reduce input current, and reduce interference generated from the motor drive. It also reduces momentary voltage surges or abnormal current spikes. For example, when the main power capacity is higher than 500 kVA, or when using a switching capacitor bank, momentary voltage and current spikes may damage the AC motor drive's internal circuit. An AC reactor on the input side of the AC motor drive protects it by suppressing surges.

### Installation

Install an AC input reactor in series with the main power to the three input phases R S T as shown below:

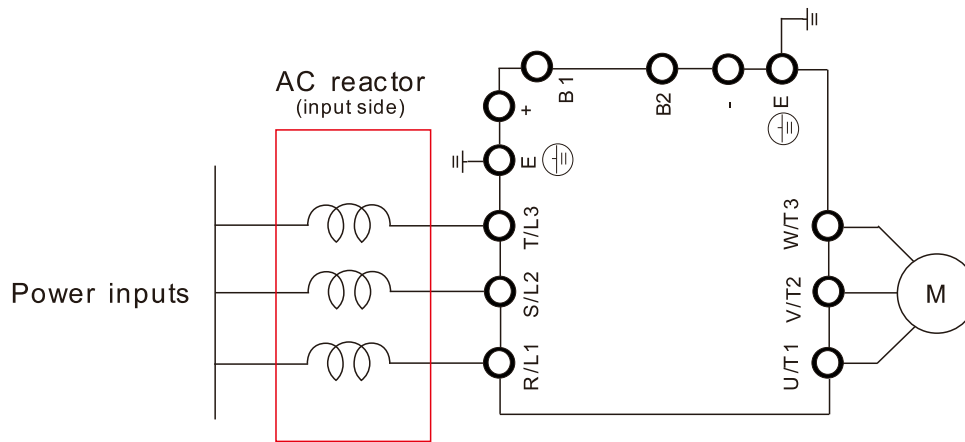

Wiring of AC input reactor

Figure 7-6

Following table shows the standard AC reactors specification of Delta C2000

200V~230V/ 50~60Hz

Model	HP	Rated Current (Arms)	Saturation current (Arms)	3% impedance (mH)	5% impedance (mH)	Built-in DC reactor	Input AC reactor Delta part #
VFD007C23A	1	5	8.64	2.536	4.227	No	DR005A0254
VFD015C23A	2	8	12.78	1.585	2.642	No	DR008A0159
VFD022C23A	3	11	18	1.152	1.922	No	DR011A0115
VFD037C23A	5	17	28.8	0.746	1.243	No	DR017AP746
VFD055C23A	7.5	25	43.2	0.507	0.845	No	DR025AP507
VFD075C23A	10	33	55.8	0.32	0.534	No	DR033AP320
VFD110C23A	15	49	84.6	0.216	0.359	No	DR049AP215
VFD150C23A	20	65	111.6	0.163	0.271	No	DR065AP163
VFD185C23A	25	75	127.8	0.169	0.282	No	DR075AP170
VFD220C23A	30	90	154.8	0.141	0.235	No	DR090AP141
VFD300C23A	40	120	205.2	0.106	0.176	Yes	DR146AP087
VFD370C23A	50	146	250.2	0.087	0.145	Yes	DR146AP087
VFD450C23A	60	180	307.8	0.070	0.117	Yes	DR180AP070
VFD550C23A	75	215	367.2	0.059	0.098	Yes	DR215AP059
VFD750C23A	100	255	435.6	0.049	0.083	Yes	DR276AP049
VFD900C23A	125	346	592.2	0.037	0.061	Yes	DR349AP037

Table 7-15

380V~460V/ 50~60Hz

Model	HP	Rated Current (Arms)	Saturation current (Arms)	3% impedance (mH)	5% impedance (mH)	Built-in DC reactor	Input AC reactor Delta part #
VFD007C43A	1	3	5.22	8.102	13.502	No	DR003A0810
VFD015C43A	2	4	6.84	6.077	10.127	No	DR004A0607
VFD022C43A	3	6	10.26	4.050	6.752	No	DR006A0405
VFD037C43A	5	9	14.58	2.700	4.501	No	DR009A0270
VFD040C43A	5	10.5	17.1	2.315	3.858	No	DR010A0231
VFD055C43A	7.5	12	19.8	2.025	3.375	No	DR012A0202
VFD075C43A	10	18	30.6	1.174	1.957	No	DR018A0117
VFD110C43A	15	24	41.4	0.881	1.468	No	DR024AP881
VFD150C43A	20	32	54	0.66	1.101	No	DR032AP660
VFD185C43A	25	38	64.8	0.639	1.066	No	DR038AP639
VFD220C43A	30	45	77.4	0.541	0.900	No	DR045AP541
VFD300C43A	40	60	102.6	0.405	0.675	Yes	DR060AP405
VFD370C43S/U	50	73	124.2	0.334	0.555	Yes	DR073AP334
VFD450C43S/U	60	91	154.8	0.267	0.445	Yes	DR091AP267
VFD550C43A	75	110	189	0.221	0.368	Yes	DR110AP221
VFD750C43A	100	150	257.4	0.162	0.270	Yes	DR150AP162
VFD900C43A	125	180	307.8	0.135	0.225	Yes	DR180AP135
VFD1100C43A	150	220	376.2	0.110	0.184	Yes	DR220AP110
VFD1320C43A	175	260	444.6	0.098	0.162	Yes	DR260AP098
VFD1600C43A	215	310	531	0.078	0.131	Yes	DR310AP078
VFD1850C43A	250	370	633.6	0.066	0.109	Yes	DR370AP066
VFD2200C43A	300	460	786.6	0.054	0.090	Yes	DR460AP054
VFD2800C43A	375	550	941.4	0.044	0.074	Yes	DR550AP044
VFD3150C43A	420	616	1053	0.039	0.066	Yes	DR616AP039
VFD3550C43A	475	683	1168.2	0.036	0.060	Yes	DR683AP036
VFD4500C43A	600	866	1468.8	0.028	0.047	Yes	DR866AP028

Table 7-16

575V, 50/60 Hz, 3-phase

kW	HP	Rated current (Arms)			Saturation Current (Arms)	3% impedance (mH)			5% impedance (mH)		
		Light Duty	Normal Duty	Heavy Duty		Light Duty	Normal Duty	Heavy Duty	Light Duty	Normal Duty	Heavy Duty
VFD015C53A-21	2	3	2.5	2.1	4.2	8.806	10.567	12.580	14.677	17.612	20.967
VFD022C531-21	3	4.3	3.6	3	5.9	6.144	7.338	8.806	10.239	12.230	14.677
VFD037C53A-21	5	6.7	5.5	4.6	9.1	3.943	4.803	5.743	6.572	8.005	9.572
VFD055C53A-21	7.5	9.9	8.2	6.9	13.7	2.668	3.222	3.829	4.447	5.369	6.381
VFD075C53A-21	10	12.1	10	8.3	16.5	2.183	2.642	3.183	3.639	4.403	5.305
VFD110C53A-21	15	18.7	15.5	13	25.7	1.413	1.704	2.032	2.355	2.841	3.387
VFD150C53A-21	20	24.2	20	16.8	33.3	1.092	1.321	1.572	1.819	2.201	2.621

Table 7-17

690V, 50/60 Hz, 3-phase

kW	HP	Rated current			Saturation Current			3% Impedance			5% Impedance		
		(Arms)			(Arms)			(mH)			(mH)		
		Light Duty	Normal Duty	Heavy Duty	Light Duty	Normal Duty	Heavy Duty	Light Duty	Normal Duty	Heavy Duty	Light Duty	Normal Duty	Heavy Duty
VFD185C63B-21	25	24	20	14	28.8	30.0	25.2	1.585	1.902	2.717	2.642	3.170	4.529
VFD220C63B-21	30	30	24	20	36.0	36.0	36.0	1.268	1.585	1.902	2.113	2.642	3.170
VFD300C63B-21	40	36	30	24	43.2	45.0	43.2	1.057	1.268	1.585	1.761	2.113	2.642
VFD370C63B-21	50	45	36	30	54.0	54.0	54.0	0.845	1.057	1.268	1.409	1.761	2.113
VFD450C63B-00/21	60	54	45	36	64.8	67.5	64.8	0.704	0.845	1.057	1.174	1.409	1.761
VFD550C63B-00/21	75	67	54	45	80.4	81.0	81.0	0.568	0.704	0.845	0.946	1.174	1.409
VFD750C63B-00/21	100	86	67	54	103.2	100.5	97.2	0.442	0.568	0.704	0.737	0.946	1.174
VFD900C63B-00/21	125	104	86	67	124.8	129.0	120.6	0.366	0.442	0.568	0.610	0.737	0.946
VFD1100C63B-00/21	150	125	104	86	150.0	156.0	154.8	0.304	0.366	0.442	0.507	0.610	0.737
VFD1320C63B-00/21	175	150	125	104	180.0	187.5	187.2	0.254	0.304	0.366	0.423	0.507	0.610
VFD1600C63B-00/21	215	180	150	125	216.0	225.0	225.0	0.211	0.254	0.304	0.352	0.423	0.507
VFD2000C63B-00/21	270	220	180	150	264.0	270.0	270.0	0.173	0.211	0.254	0.288	0.352	0.423
VFD2500C63B-00/21	335	290	220	180	348.0	330.0	324.0	0.131	0.173	0.211	0.219	0.288	0.352
VFD3150C63B-00/21	425	350	290	220	420.0	435.0	396.0	0.109	0.131	0.173	0.181	0.219	0.288
VFD4000C63B-00/21	530	430	350	290	516.0	525.0	522.0	0.088	0.109	0.131	0.147	0.181	0.219
VFD4500C63B-00/21	600	465	385	310	558.0	577.5	558.0	0.082	0.099	0.123	0.136	0.165	0.205
VFD5600C63B-00/21	745	590	465	420	708.0	697.5	756.0	0.064	0.082	0.091	0.107	0.136	0.151
VFD6300C63B-00/21	850	675	675	675	810.0	1012.5	1215.0	0.056	0.056	0.056	0.094	0.094	0.094

Table 7-18

AC input reactor dimension and specifications:

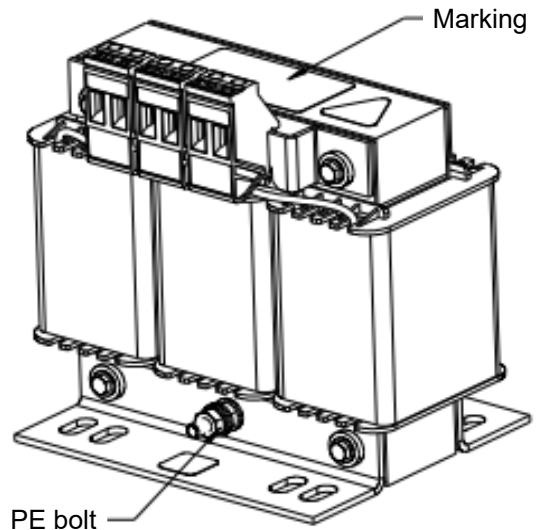
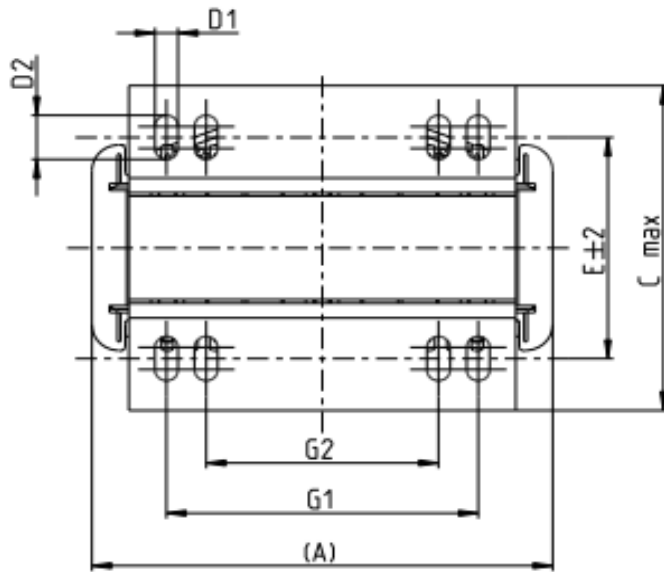

Tightening torque: 10.2~12.3 kg-cm / [8.9~10.6 lb-in.] / [1.0~1.2 Nm]

Tightening torque: 6.1~8.2 kg-cm / [5.3~7.1 lb-in.] / [0.6~0.8 Nm]

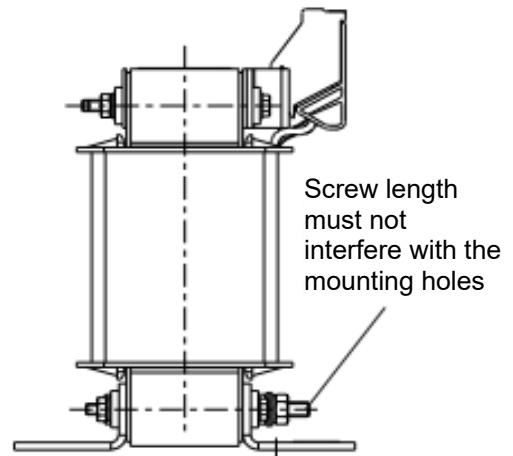
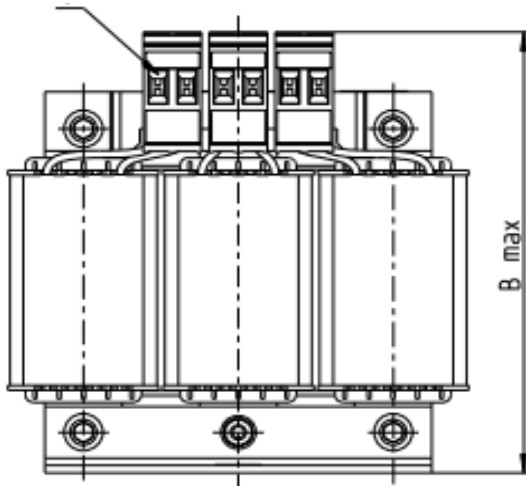

Unit: mm

Model	Input AC reactor Delta part #	A	B	C	D1*D2	E	G1	G2	PE D
VFD007C23A	DR005A0254	96	100	60	6*9	42	60	40	M4
VFD015C23A	DR008A0159	120	120	88	6*12	60	80.5	60	M4
VFD022C23A	DR011A0115	120	120	88	6*12	60	80.5	60	M4
VFD037C23A	DR017AP746	120	120	93	6*12	65	80.5	60	M4
VFD055C23A	DR025AP507	150	150	112	6*12	88	107	75	M4
VFD075C23A	DR033AP320	150	150	112	6*12	88	107	75	M4

Table 7-19

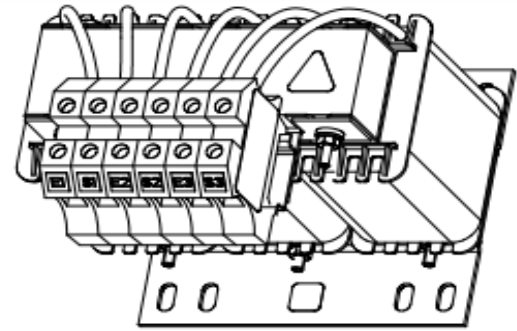
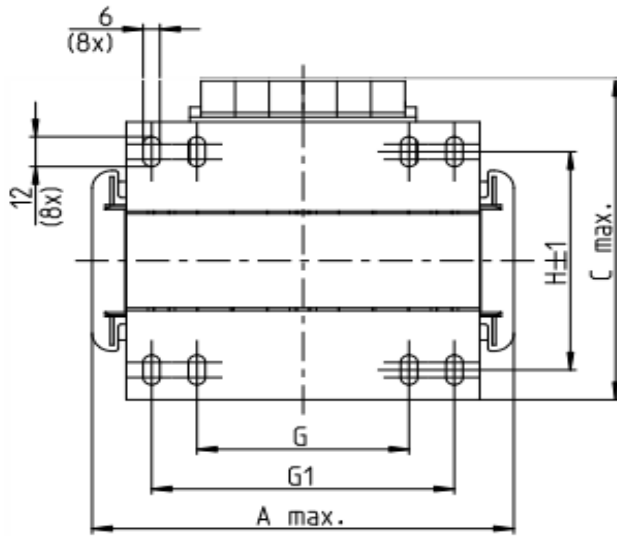

Terminals Q mm<sup>2</sup>  
Tightening torque M Nm

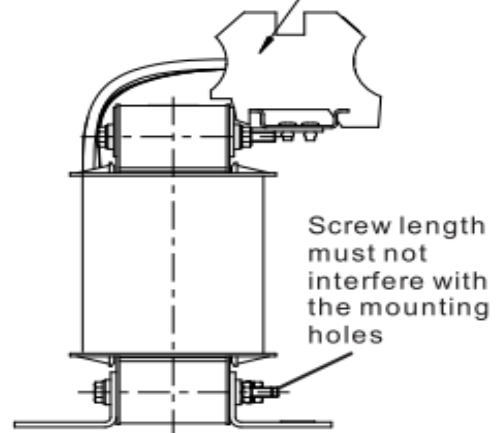
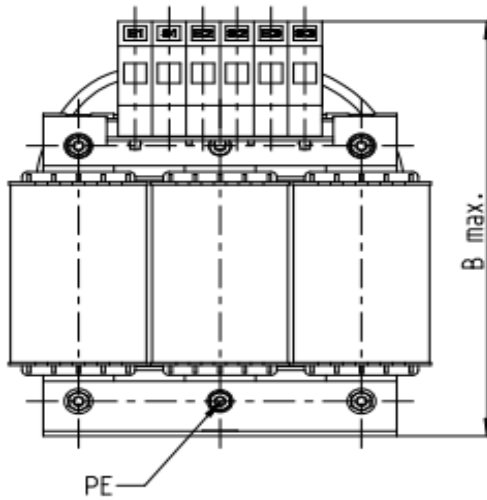

Unit: mm

Model	Input AC reactor Delta part #	A	B	C	D1*D2	H	G	G1	Q	M	PE D
VFD110C23A	DR049AP215	180	195	160	6*12	115	85	122	16	1.2~1.4	M4
VFD150C23A	DR065AP163	180	205	160	6*12	115	85	122	35	2.5~3.0	M4

Table 7-20

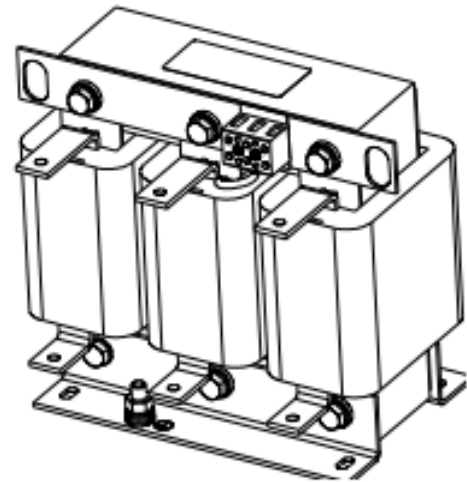
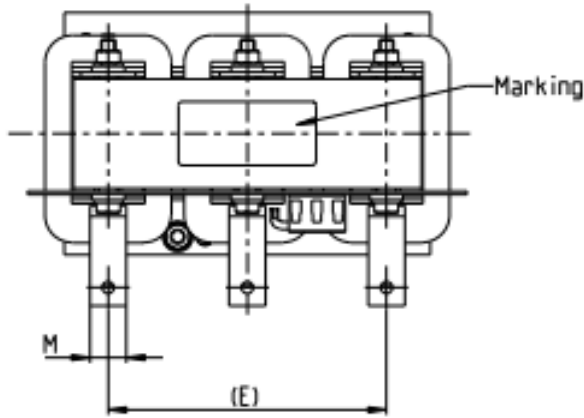
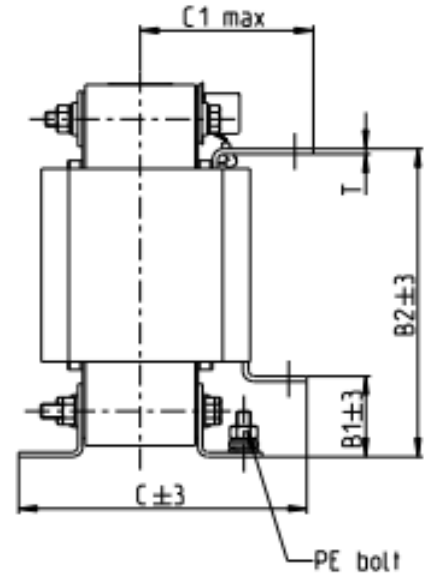
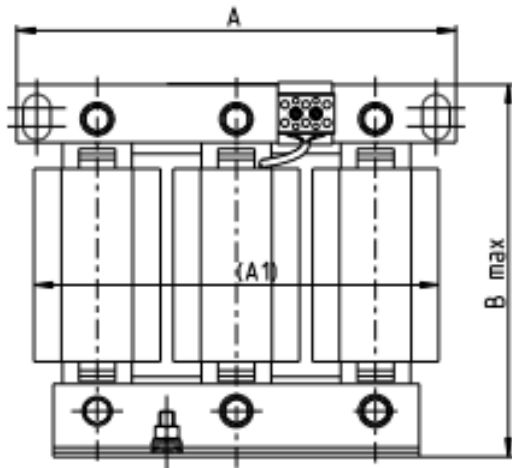
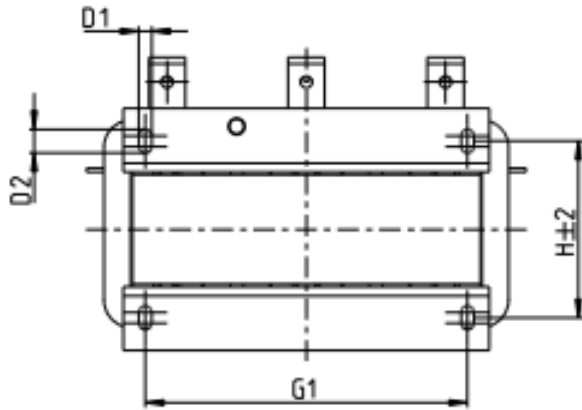

Unit: mm

Model	Input AC reactor Delta part #	A	A1	B	B1	B2	C	C1	D1*D2	E	G1	H	M*T	PE
VFD185C23A	DR075AP170	240	220	205	42	165	151	95	7*13	152	176	85	20*3	M8
VFD220C23A	DR090AP141	240	225	210	44	170	151	95	7*13	152	176	85	20*3	M8
VFD300C23A VFD370C23A	DR146AP087	240	225	240	44	200	163	100	7*13	152	176	97	20*3	M8
VFD450C23A	DR180AP070	250	235	250	49	206	175	105	11*18	160	190	124	30*3	M8
VFD550C23A	DR215AP059	250	235	275	51	226	180	110	11*18	160	190	124	30*5	M8

Table 7-21

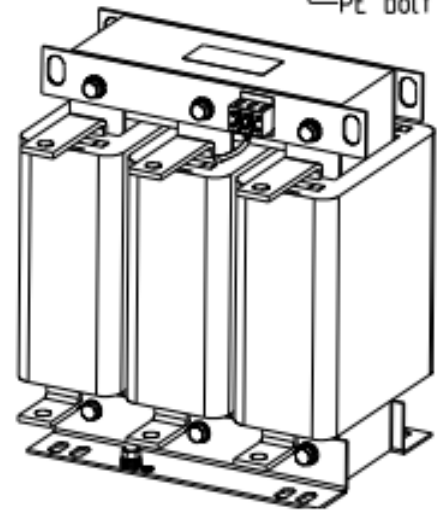
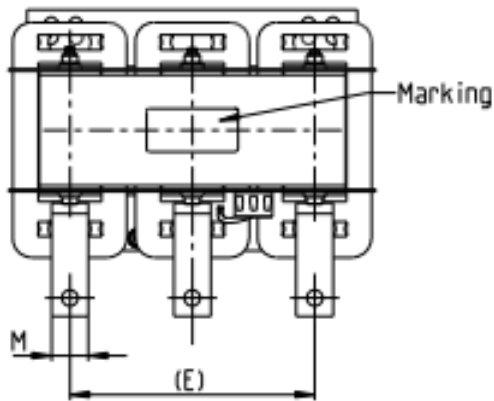
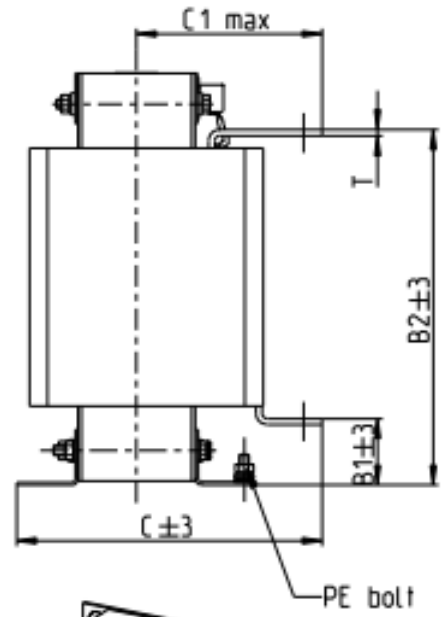
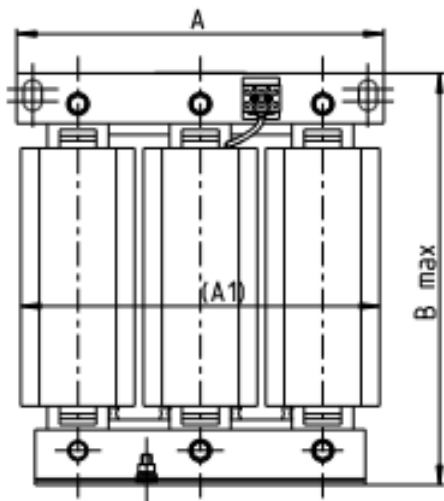
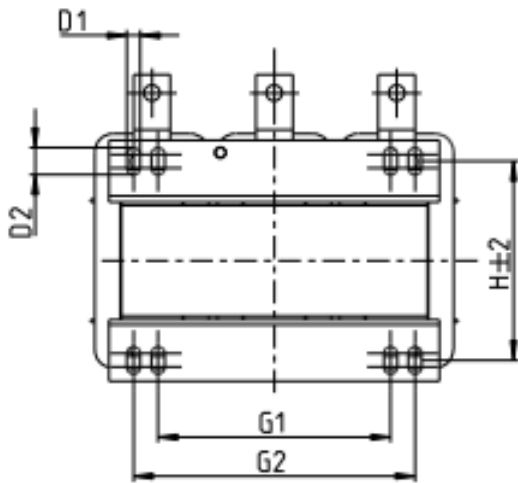

Unit: mm

Model	Input AC reactor Delta part #	A	A1	B	B1	B2	C	C1	D1*D2	E	G1	H	M*T	PE
VFD750C23A	DR276AP049	270	255	310	50	265	200	130	10*18	176	200	106	30*5	M8
VFD900C23A	DR349AP037	270	260	333	50	285	200	130	10*18	176	200	106	30*5	M8

Table 7-22

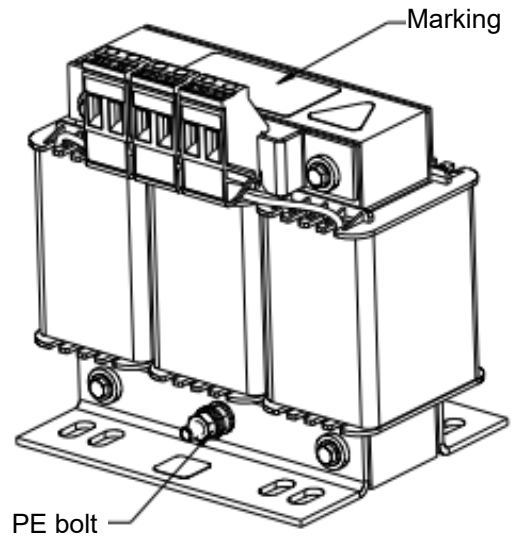
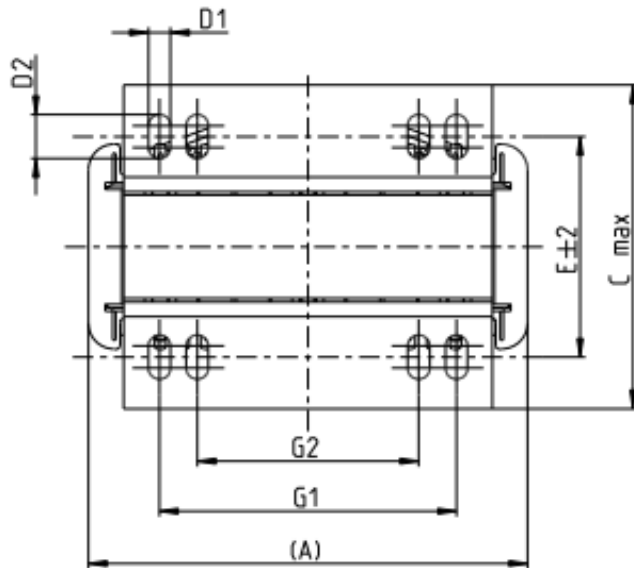

Tightening torque: 10.2~12.3 kg-cm / [8.9~10.6 lb-in.] / [1.0~1.2 Nm]

Tightening torque: 6.1~8.2 kg-cm / [5.3~7.1 lb-in.] / [0.6~0.8 Nm]

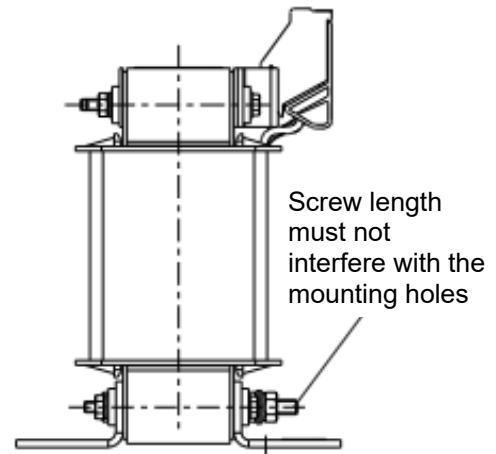
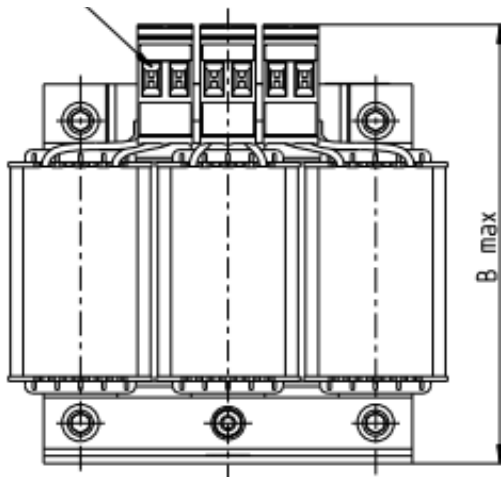

Unit: mm

Model	Input AC reactor Delta part #	A	B	C	D1*D2	E	G1	G2	PE D
VFD007C43A	DR003A0810	96	100	60	6*9	42	60	40	M4
VFD015C43A	DR004A0607	120	120	88	6*12	60	80.5	60	M4
VFD022C43A	DR006A0405	120	120	88	6*12	60	80.5	60	M4
VFD037C43A	DR009A0270	150	150	88	6*12	74	107	75	M4
VFD040C43A	DR010A0231	150	150	112	6*12	88	107	75	M4
VFD055C43A	DR012A0202	150	150	112	6*12	88	107	75	M4
VFD075C43A	DR018A0117	150	155	112	6*12	88	107	75	M4
VFD110C43A	DR024AP881	150	155	112	6*12	88	107	75	M4
VFD150C43A	DR032AP660	180	175	138	6*12	114	122	85	M6

Table 7-23



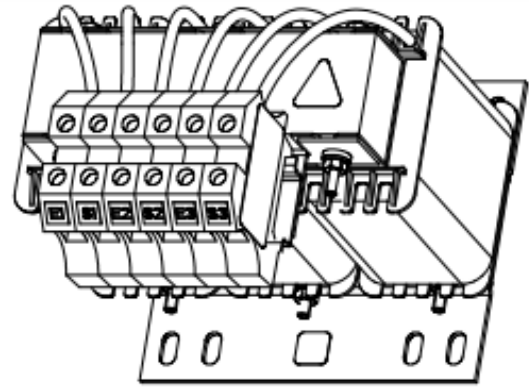
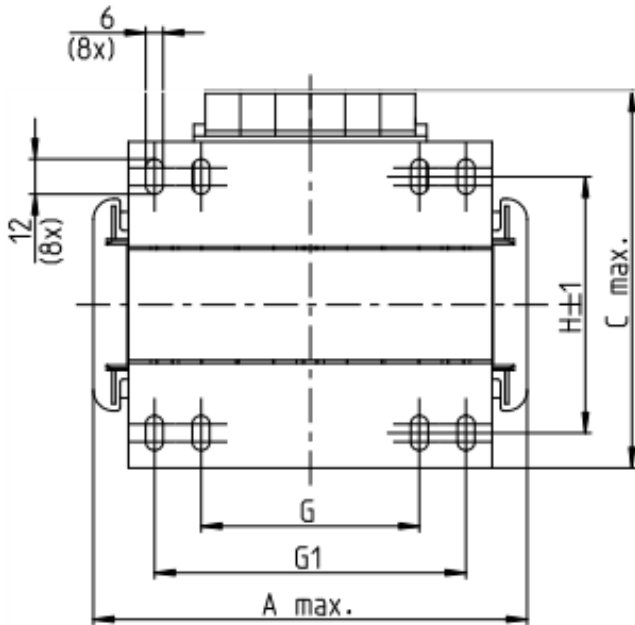

Terminals Q mm<sup>2</sup>  
Tightening torque M Nm

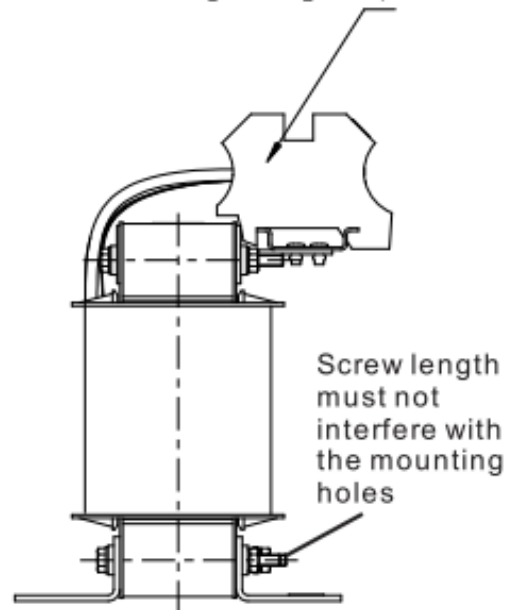
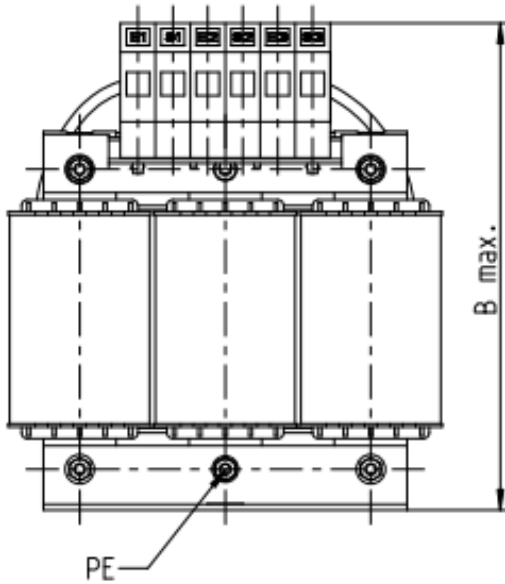

Unit: mm

Model	Input AC reactor Delta part #	A	B	C	D1*D2	H	G	G1	Q	M	PE D
VFD185C43A	DR038AP639	180	195	160	6*12	115	85	122	16	1.2~1.4	M4
VFD220C43A	DR045AP541	235	235	145	7*13	85	/	176	16	1.2~1.4	M6

Table 7-24

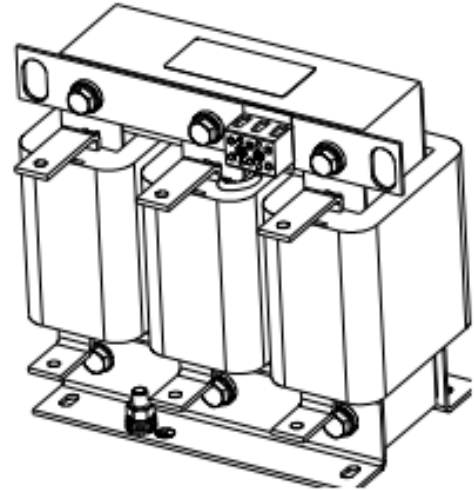
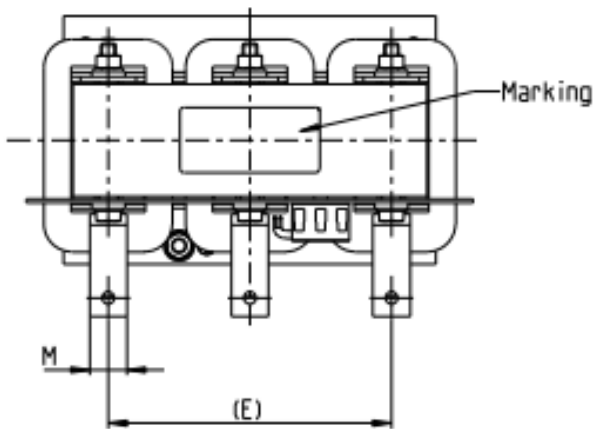
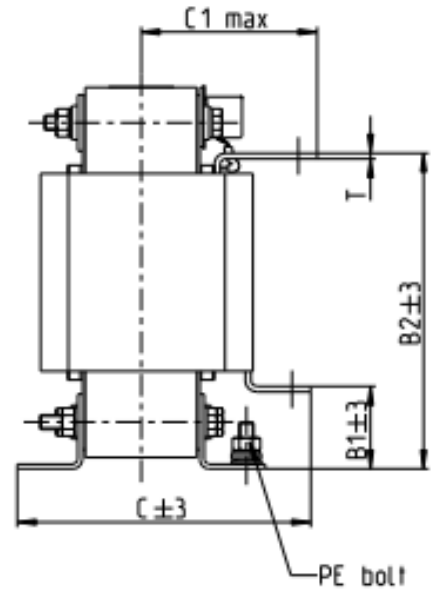
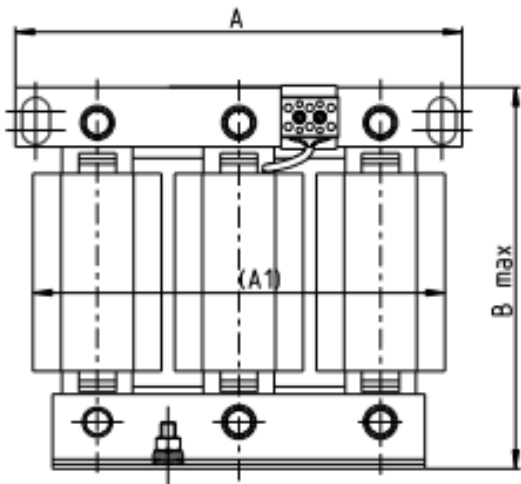
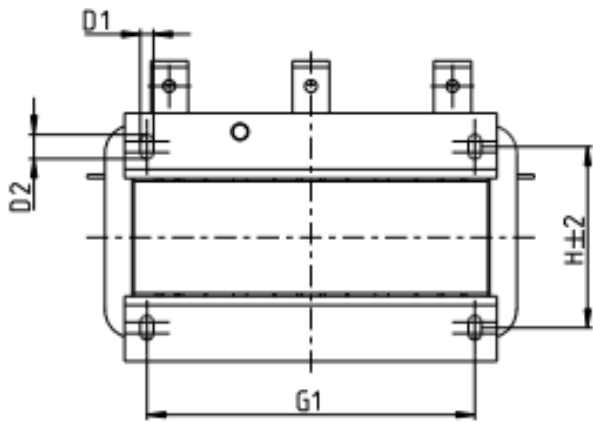

Unit: mm

Model	Input AC reactor Delta part #	A	A1	B	B1	B2	C	C1	D1*D2	E	G1	H	M*T	PE
VFD300C43A	DR060AP405	240	225	210	44	170	163	100	7*13	152	176	97	20*3	M8
VFD370C43S/U	DR073AP334	250	230	225	44	186	174	105	11*18	160	190	124	20*3	M8
VFD450C43S/U	DR091AP267	250	235	225	44	186	174	105	11*18	160	190	124	20*3	M8
VFD550C43A	DR110AP221	270	255	235	50	192	175	105	10*18	176	200	106	20*3	M8

Table 7-25

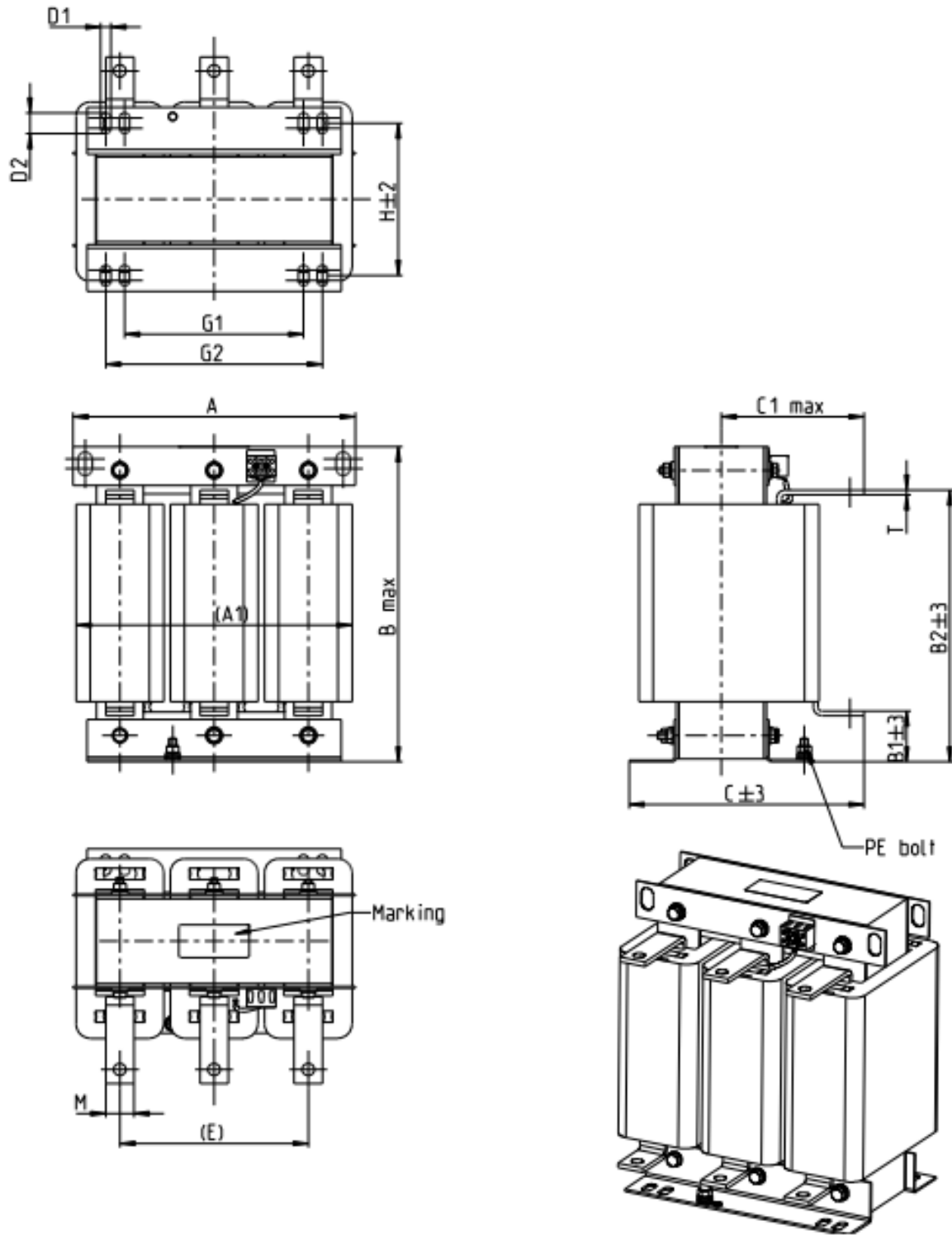

Unit: mm

Model	Input AC reactor Delta part #	A	A1	B	B1	B2	C	C1	D1*D2	E	G1	G2	H	M*T
VFD750C43A	DR150AP162	270	260	260	51	208	195	120	10*18	176	200	/	118	30*3
VFD900C43A	DR180AP135	300	290	300	55	246	195	115	11*22	200	230	190	142	30*3
VFD1100C43A	DR220AP110	300	295	300	57	248	210	130	11*22	200	230	190	142	30*5
VFD1320C43A	DR260AP098	300	290	330	56	270	227	140	11*22	200	230	190	160	30*5
VFD1600C43A	DR310AP078	300	295	340	54	288	233	145	11*22	200	230	190	160	30*5
VFD1850C43A	DR370AP066	300	295	340	54	289	268	168	11*22	200	230	190	185	40*3

Table 7-26

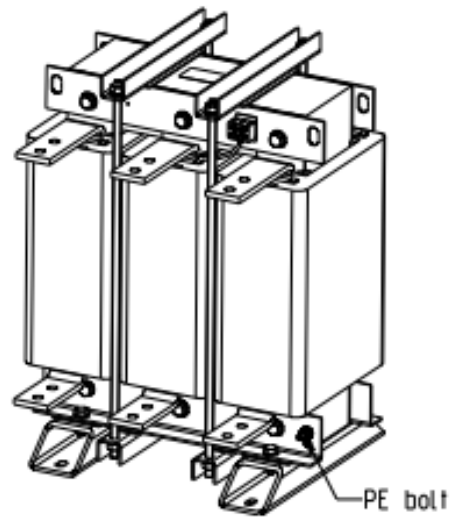
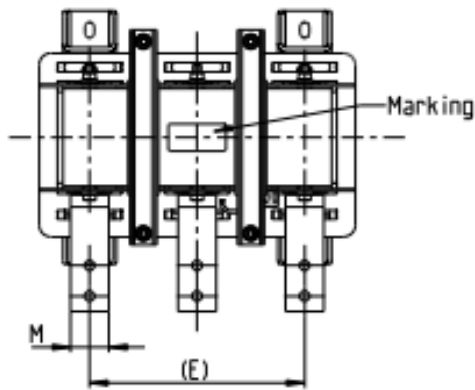
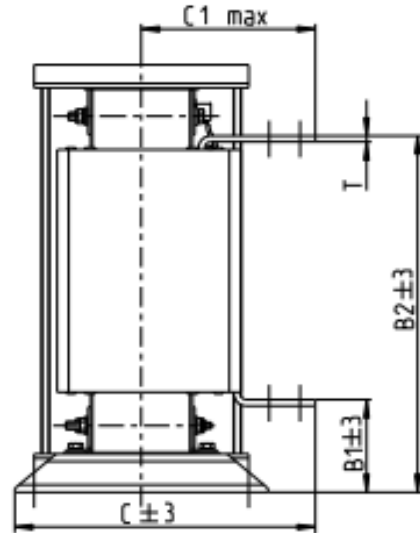
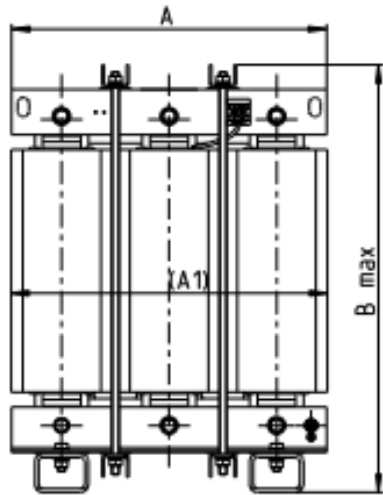
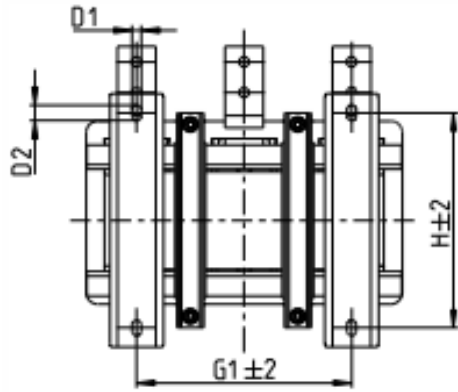

Unit: mm

Model	Input AC reactor Delta part #	A	A1	B	B1	B2	C	C1	D1*D2	E	G1	H	M*T	PE
VFD2200C43A	DR460AP054	360	350	490	106	401	346	205	12*20	240	240	240	50*5	M8
VFD2800C43A	DR550AP044	360	350	490	106	401	358	210	12*20	240	240	250	50*5	M8
VFD3150C43A	DR616AP039	360	350	490	110	401	376	225	12*20	240	240	270	50*8	M8
VFD3550C43A	DR683AP036	360	350	490	110	404	396	232	12*20	240	240	290	50*8	M8
VFD4500C43A	DR866AP028	410	415	562	120	464	402	232	12*20	280	280	290	50*8	M8

Table 7-27

**DC reactor**

A DC reactor can also improve the power factor, reduce input current, and reduce interference generated from the motor drive. A DC reactor stabilizes the DC BUS voltage. Compared to an AC input reactor, the advantages are smaller size, lower price, and lower voltage drop (lower power dissipation).

**Installation**

Install the DC reactor between terminals +2/DC+ and +1/DC+. Remove the jumper (shown below) before installing the DC reactor.

**Wiring Diagram for Frame A~C**

Input: 3-phase power

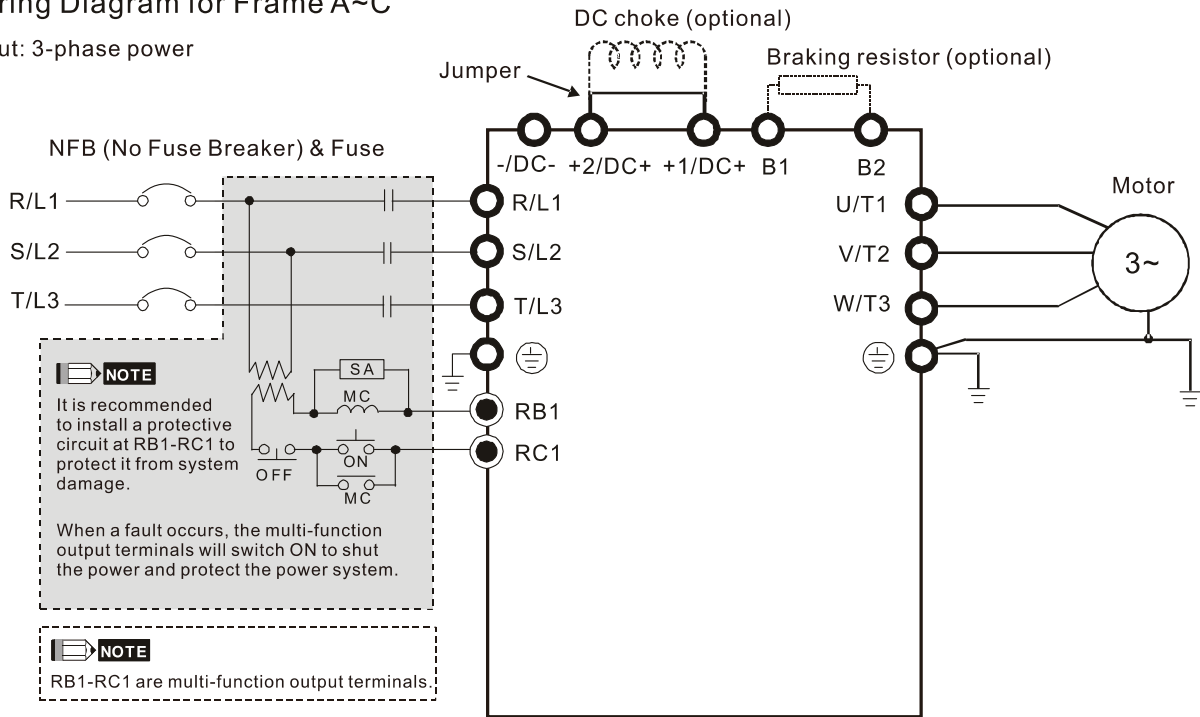

Wiring of DC reactor

Figure 7-7

DC reactor dimension and specifications:

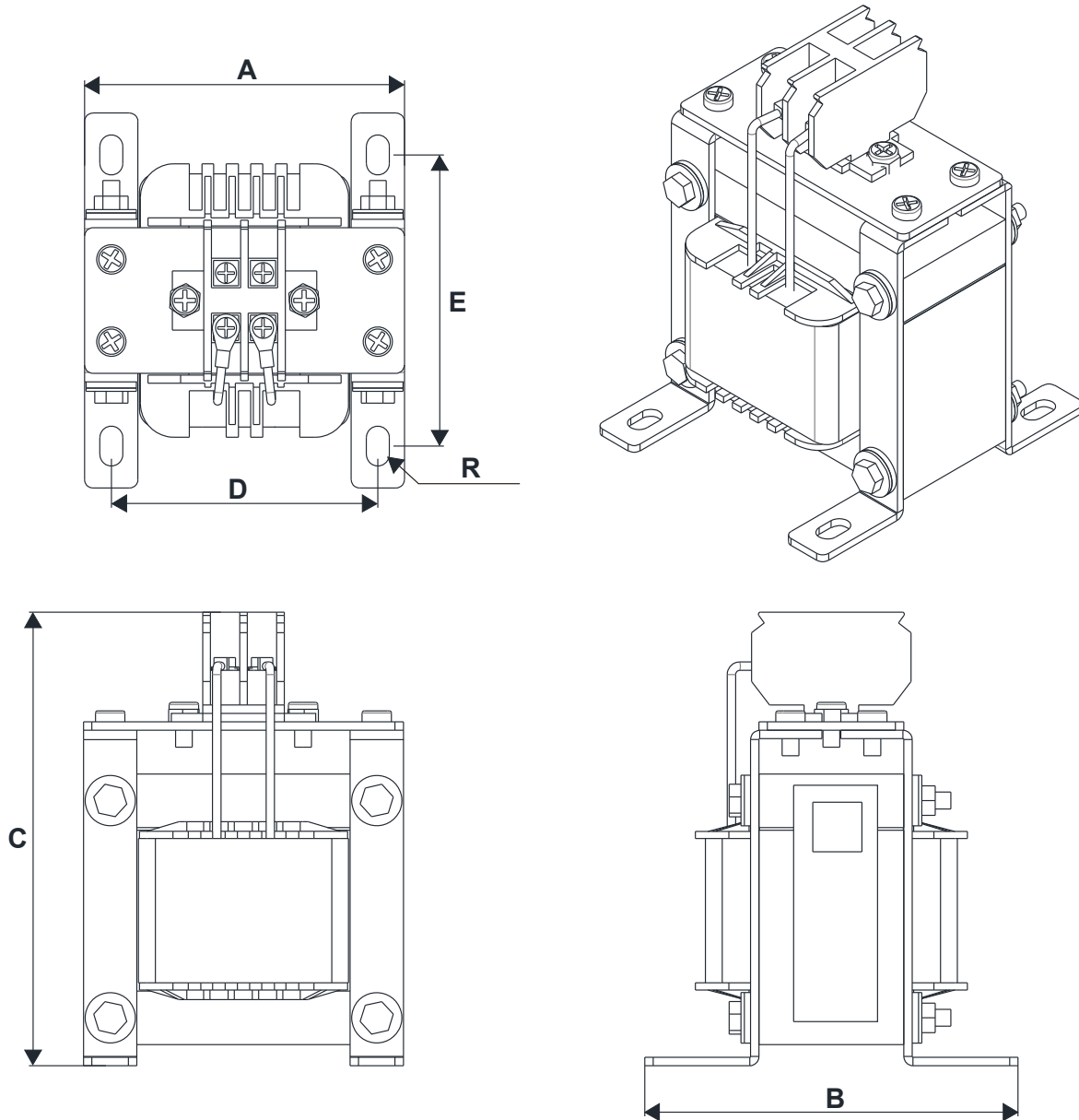

200V~230V/ 50~60Hz

Model	HP	Rated Current (Arms)	Saturation current (Arms)	DC reactor (mH)	DC reactor Delta Part #	A [mm]	B [mm]	C [mm]	D [mm]	E [mm]	R [mm]
VFD007C23A	1	5	8.64	5.857	DR005D0585	79	78	112	64±2	56±2	9.5*5.5
VFD015C23A	2	8	12.78	3.660	DR008D0366	79	78	112	64±2	56±2	9.5*5.5
VFD022C23A	3	11	18	2.662	DR011D0266	79	92	112	64±2	69.5±2	9.5*5.5
VFD037C23A	5	17	28.8	1.722	DR017D0172	79	112	112	64±2	89.5±2	9.5*5.5
VFD055C23A	7.5	25	43.2	1.172	DR025D0117	99	105	128	79±2	82.5±2	9.5*5.5
VFD075C23A	10	33	55.8	0.851	DR033DP851	117	110	156	95±2	87±2	10*6.5
VFD110C23A	15	49	84.6	0.574	DR049DP574	117	120	157	95±2	97±2	10*6.5
VFD150C23A	20	65	111.6	0.432	DR065DP432	117	140	157	95±2	116.5±2	10*6.5
VFD185C23A	25	75	127.8	0.391	DR075DP391	136	135	178	111±2	112±2	10*6.5
VFD220C23A	30	90	154.8	0.325	DR090DP325	136	135	179	111±2	112±2	10*6.5

Table 7-28

380V~460V/ 50~60Hz

Model	HP	Rated Current (Arms)	Saturation current (Arms)	DC reactor (mH)	DC reactor Delta Part #	A [mm]	B [mm]	C [mm]	D [mm]	E [mm]	R [mm]
VFD007C43A	1	3	5.22	18.709	DR003D1870	79	78	112	64±2	56±2	9.5*5.5
VFD015C43A	2	4	6.84	14.031	DR004D1403	79	92	112	64±2	69.5±2	9.5*5.5
VFD022C43A	3	6	10.26	9.355	DR006D0935	79	92	112	64±2	69.5±2	9.5*5.5
VFD037C43A	5	9	14.58	6.236	DR009D0623	79	112	112	64±2	89.5±2	9.5*5.5
VFD040C43A	5	10.5	17.1	5.345	DR010D0534	99	93	128	79±2	70±2	9.5*5.5
VFD055C43A	7.5	12	19.8	4.677	DR012D0467	99	105	128	79±2	82.5±2	9.5*5.5
VFD075C43A	10	18	30.6	3.119	DR018D0311	117	110	144	95±2	87±2	10*6.5
VFD110C43A	15	24	41.4	2.338	DR024D0233	117	120	144	95±2	97±2	10*6.5
VFD150C43A	20	32	54	1.754	DR032D0175	117	140	157	95±2	116.5±2	10*6.5
VFD185C43A	25	38	64.8	1.477	DR038D0147	136	135	172	111±2	112±2	10*6.5
VFD220C43A	30	45	77.4	1.247	DR045D0124	136	135	173	111±2	112±2	10*6.5
VFD300C43A	40	60	102.6	0.935	DR060DP935	136	150	173	111±2	127±2	10*6.5

Table 7-29

575V DC Choke

kW	HP	Rated Current (Arms)			Saturation Current (Arms)	4%DC Impedance (mH)		
		Light Duty	Normal Duty	Heavy Duty		Light Duty	Normal Duty	Heavy Duty
		VFD015C53A-21	2	3		2.5	2.1	4.2
VFD022C531-21	3	4.3	3.6	3	5.9	14.188	16.947	20.336
VFD037C53A-21	5	6.7	5.5	4.6	9.1	9.106	11.093	13.263
VFD055C53A-21	7.5	9.9	8.2	6.9	13.7	6.163	7.440	8.842
VFD075C53A-21	10	12.1	10	8.3	16.5	5.042	6.101	7.351
VFD110C53A-21	15	18.7	15.5	13	25.7	3.263	3.936	4.693
VFD150C53A-21	20	24.2	20	16.8	33.3	2.521	3.050	3.632

Table 7-30

690V DC Choke

kW	HP	Rated Current (Arms)			Saturation Current (Arms)			4%DC Impedance (mH)		
		Light Duty	Normal Duty	Heavy Duty	Light Duty	Normal Duty	Heavy Duty	Light Duty	Normal Duty	Heavy Duty
		VFD185C63B-21	25	24	20	14	28.8	30.0	25.2	3.661
VFD220C63B-21	30	30	24	20	36.0	36.0	36.0	2.928	3.661	4.393
VFD300C63B-21	40	36	30	24	43.2	45.0	43.2	2.440	2.928	3.661
VFD370C63B-21	50	45	36	30	54.0	54.0	54.0	1.952	2.440	2.928

Table 7-31

Following models are built-in DC impedance:

Frame D	VFD450C63B-00; VFD550C63B-00; VFD450C63B-21; VFD550C63B-21
Frame E	VFD750C63B-00; VFD900C63B-00; VFD1100C63B-00; VFD1320C63B-00 VFD750C63B-21; VFD900C63B-21; VFD1100C63B-21; VFD1320C63B-21
Frame F	VFD1600C63B-00; VFD2000C63B-00; VFD1600C63B-21; VFD2000C63B-21
Frame G	VFD2500C63B-00; VFD3150C63B-00; VFD2500C63B-21; VFD3150C63B-21
Frame H	VFD4000C63B-00; VFD4500C63B-00; VFD5600C63B-00; VFD6300C63B-00 VFD4000C63B-21; VFD4500C63B-21; VFD5600C63B-21; VFD6300C63B-21

Table 7-32

Following table is the THDi value of Delta motor drive matching AC/DC reactor:

Drive Spec.	Models without built-in DC reactor				Models with built-in DC reactor		
Reactor Spec.	No AC/DC reactor	3% input AC reactor	5% input AC reactor	4% DC reactor	No AC/DC reactor	3% input AC reactor	5% input AC reactor
5th	73.3%	38.5%	30.8%	25.5%	31.16%	27.01%	25.5%
7th	52.74%	15.3%	9.4%	18.6%	23.18%	9.54%	8.75%
11th	7.28%	7.1%	6.13%	7.14%	8.6%	4.5%	4.2%
13th	0.4%	3.75%	3.15%	0.48%	7.9%	0.22%	0.17%
THDi	91%	43.6%	34.33%	38.2%	42.28%	30.5%	28.4%
Note:	THDi may have some difference due to different installation conditions (like wires or motors) and environment.						

Table 7-33

### AC Output reactor

Installing an AC reactor on the input side of an AC motor drive can increase line impedance, improve the power factor, reduce input current, and reduce interference generated from the motor drive. It also reduces momentary voltage surges or abnormal current spikes. For example, when the main power capacity is higher than 500 kVA, or when using a switching capacitor bank, momentary voltage and current spikes may damage the AC motor drive's internal circuit. An AC reactor on the input side of the AC motor drive protects it by suppressing surges.

### Installation

Install an AC input reactor in series with the three output phases U V W to Motor as shown below:

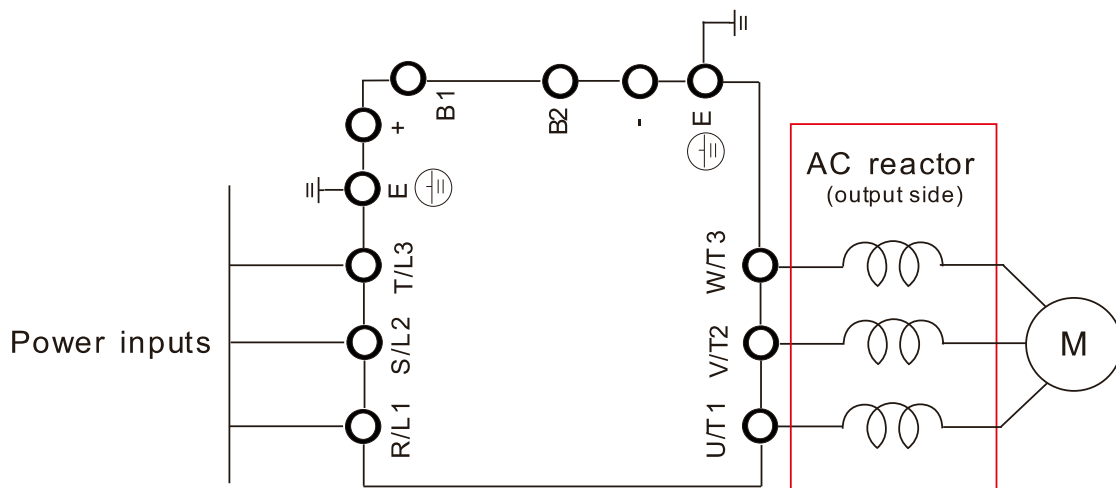

Wiring of AC output reactor

Figure 7-8



Following table shows the standard AC output reactors specification of Delta C2000

200V~230V/ 50~60Hz

Model	HP	Rated Current (Arms)	Saturation current (Arms)	3% impedance (mH)	5% impedance (mH)	Built-in DC reactor	Input AC reactor Delta part #
VFD007C23A	1	5	8.64	2.536	4.227	No	DR005L0254
VFD015C23A	2	8	12.78	1.585	2.642	No	DR008L0159
VFD022C23A	3	11	18	1.152	1.922	No	DR011L0115
VFD037C23A	5	17	28.8	0.746	1.243	No	DR017LP746
VFD055C23A	7.5	25	43.2	0.507	0.845	No	DR025LP507
VFD075C23A	10	33	55.8	0.32	0.534	No	DR033LP320
VFD110C23A	15	49	84.6	0.216	0.359	No	DR049LP215
VFD150C23A	20	65	111.6	0.163	0.271	No	DR065LP162
VFD185C23A	25	75	127.8	0.169	0.282	No	DR075LP170
VFD220C23A	30	90	154.8	0.141	0.235	No	DR090LP141
VFD300C23A	40	120	205.2	0.106	0.176	Yes	DR146LP087
VFD370C23A	50	146	250.2	0.087	0.145	Yes	DR146LP087
VFD450C23A	60	180	307.8	0.070	0.117	Yes	DR180LP070
VFD550C23A	75	215	367.2	0.059	0.098	Yes	DR215LP059
VFD750C23A	100	255	435.6	0.049	0.083	Yes	DR276LP049
VFD900C23A	125	346	592.2	0.037	0.061	Yes	DR346LP037

Table 7-34

380V~460V/ 50~60Hz

Model	HP	Rated Current (Arms)	Saturation current (Arms)	3% impedance (mH)	5% impedance (mH)	Built-in DC reactor	Delta part #
VFD007C43A	1	3	5.22	8.102	13.502	No	DR003L0810
VFD015C43A	2	4	6.84	6.077	10.127	No	DR004L0607
VFD022C43A	3	6	10.26	4.050	6.752	No	DR006L0405
VFD037C43A	5	9	14.58	2.700	4.501	No	DR009L0270
VFD040C43A	5	10.5	17.1	2.315	3.858	No	DR010L0231
VFD055C43A	7.5	12	19.8	2.025	3.375	No	DR012L0202
VFD075C43A	10	18	30.6	1.174	1.957	No	DR018L0117
VFD110C43A	15	24	41.4	0.881	1.468	No	DR024LP881
VFD150C43A	20	32	54	0.66	1.101	No	DR032LP660
VFD185C43A	25	38	64.8	0.639	1.066	No	DR038LP639
VFD220C43A	30	45	77.4	0.541	0.900	No	DR045LP541
VFD300C43A	40	60	102.6	0.405	0.675	No	DR060LP405
VFD370C43S/U	50	73	124.2	0.334	0.555	Yes	DR073LP334
VFD450C43S/U	60	91	154.8	0.267	0.445	Yes	DR091LP267
VFD550C43A	75	110	189	0.221	0.368	Yes	DR110LP221
VFD750C43A	100	150	257.4	0.162	0.270	Yes	DR150LP162
VFD900C43A	125	180	307.8	0.135	0.225	Yes	DR180LP135

Model	HP	Rated Current (Arms)	Saturation current (Arms)	3% impedance (mH)	5% impedance (mH)	Built-in DC reactor	Delta part #
VFD1100C43A	150	220	376.2	0.110	0.184	Yes	DR220LP110
VFD1320C43A	175	260	444.6	0.098	0.162	Yes	DR260LP098
VFD1600C43A	215	310	531	0.078	0.131	Yes	DR310LP078
VFD1850C43A	250	370	633.6	0.066	0.109	Yes	DR370LP066
VFD2200C43A	300	460	786.6	0.054	0.090	Yes	DR460LP054
VFD2800C43A	375	550	941.4	0.044	0.074	Yes	DR550LP044
VFD3150C43A	420	616	1053	0.039	0.066	Yes	DR616LP039
VFD3550C43A	475	683	1168.2	0.036	0.060	Yes	DR683LP036
VFD4500C43A	600	866	1468.8	0.028	0.047	Yes	DR866LP028

Table 7-35

AC output reactor dimensions and specification:

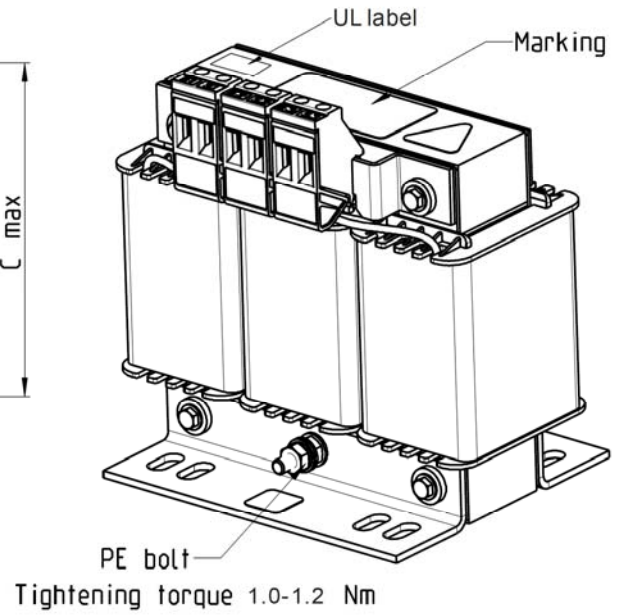
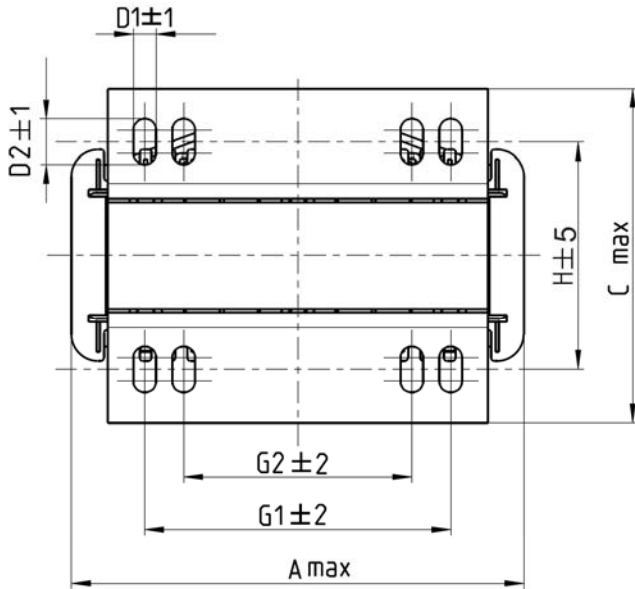

Tightening torque 0.6-0.8Nm

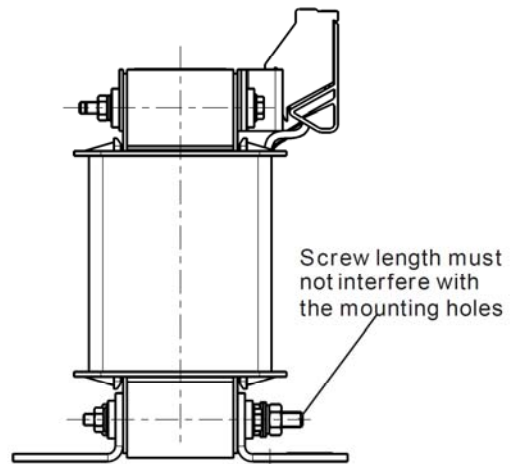
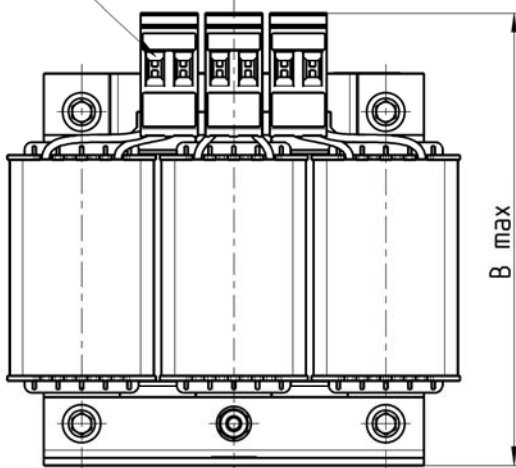

Model	Output AC reactor Delta part #	A	B	C	D1*D2	H	H1	H2	PE
VFD007C23A	DR005A0254	96	110	70	6*9	42	60	40	M4
VFD015C23A	DR008A0159	120	135	96	6*12	60	80.5	60	M4
VFD022C23A	DR011A0115	120	135	96	6*12	60	80.5	60	M4
VFD037C23A	DR017AP746	120	135	105	6*12	65	80.5	60	M4
VFD055C23A	DR025AP507	150	160	120	6*12	88	107	75	M4
VFD075C23A	DR033AP320	150	160	120	6*12	88	107	75	M4

Table 7-36

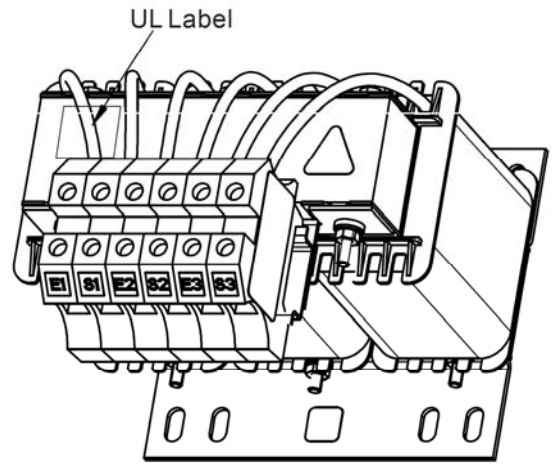
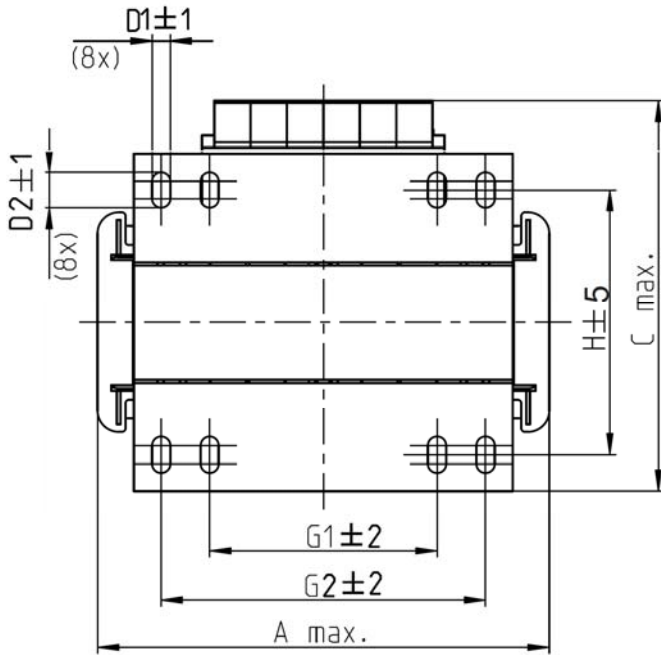

Terminals 16 mm<sup>2</sup>  
Tightening torque 1.2-1.4

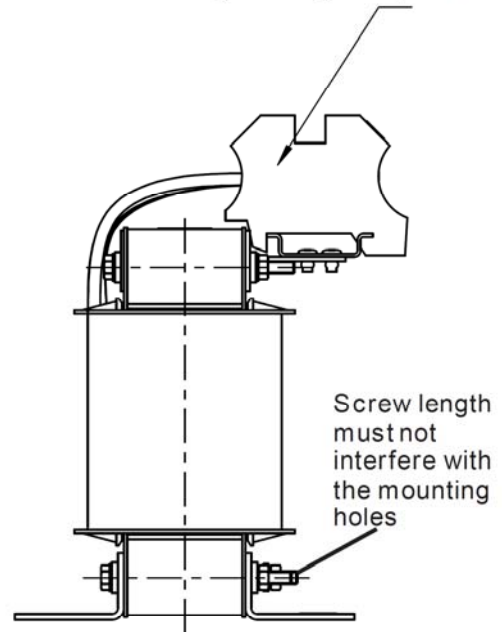
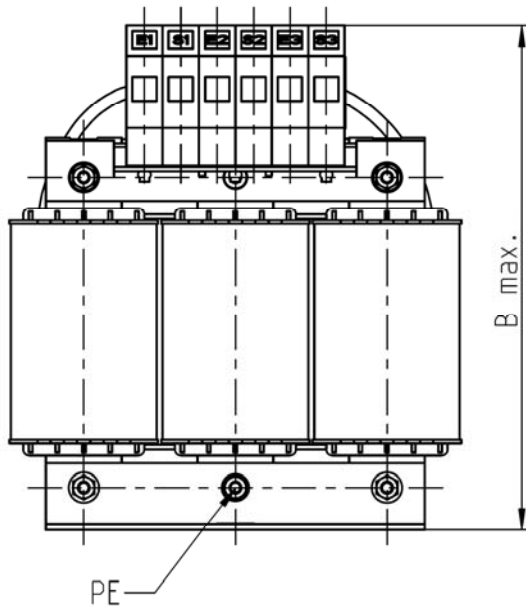

Model	Output AC reactor Delta part #	A	B	C	D1*D2	H	G	G1	Q	M	PE
VFD110C23A	DR049AP215	180	205	175	6*12	115	85	122	16	1.2-1.4	M4
VFD150C23A	DR065AP162	180	215	185	6*12	115	85	122	35	2.5-3.0	M4

Table 7-37

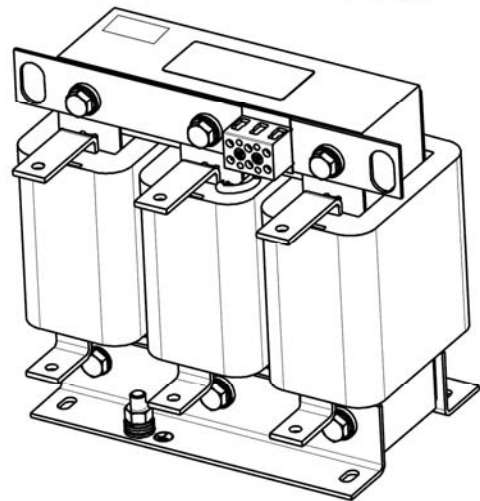
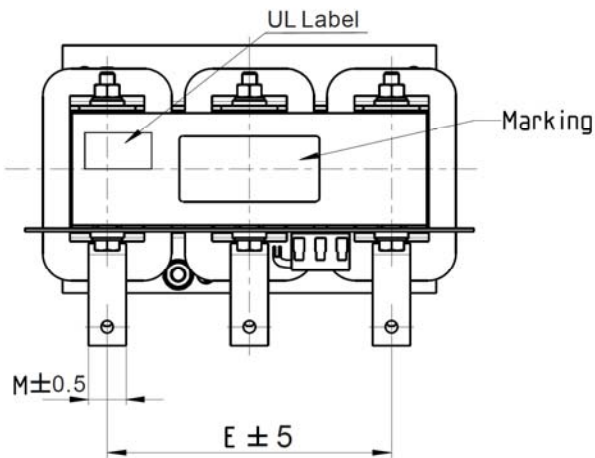
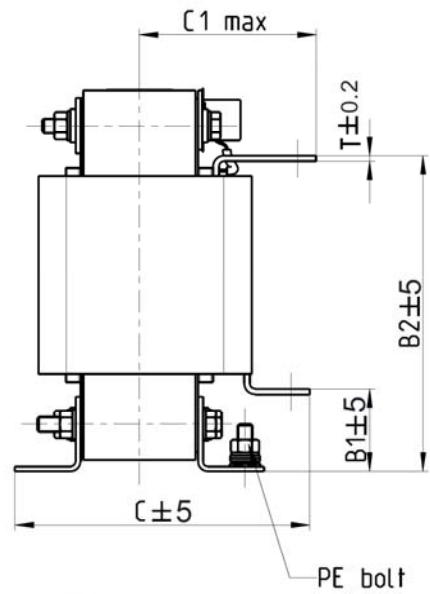
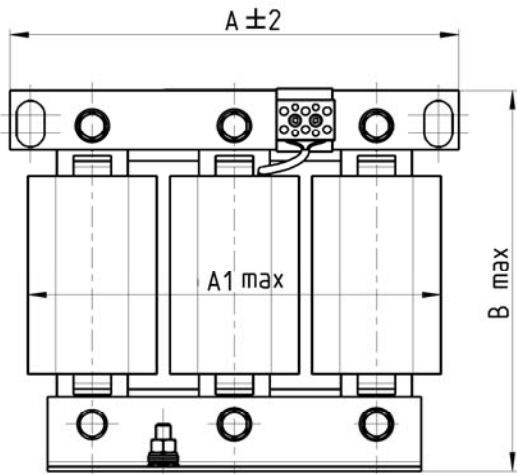
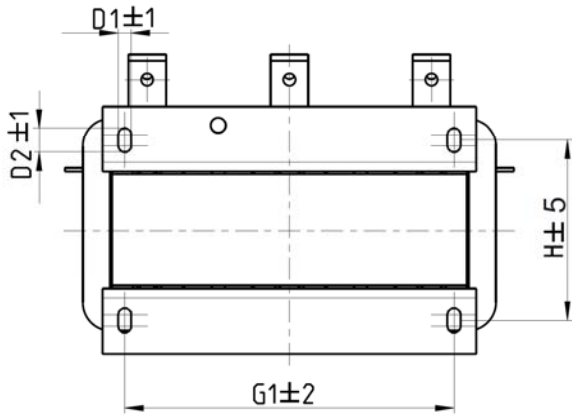

Model	Output AC reactor Delta part #	A	A1	B	B1	B2	C	C1	D1*D2	E	G1	H	M*T
VFD185C23A	DR075AP170	240	228	210	44	170	151	95	7*13	152	176	85	20*3
VFD220C23A	DR090AP141	240	228	220	44	170	151	100	7*13	152	176	85	20*3
VFD300C23A VFD370C23A	DR146AP087	240	228	250	45	202	162	110	7*13	152	176	97	30*3
VFD450C23A	DR180AP070	250	240	260	46	203	175	115	11*18	160	190	124	30*5
VFD550C23A	DR215AP059	250	240	285	51	226	180	120	11*18	160	190	124	30*5

Table 7-38

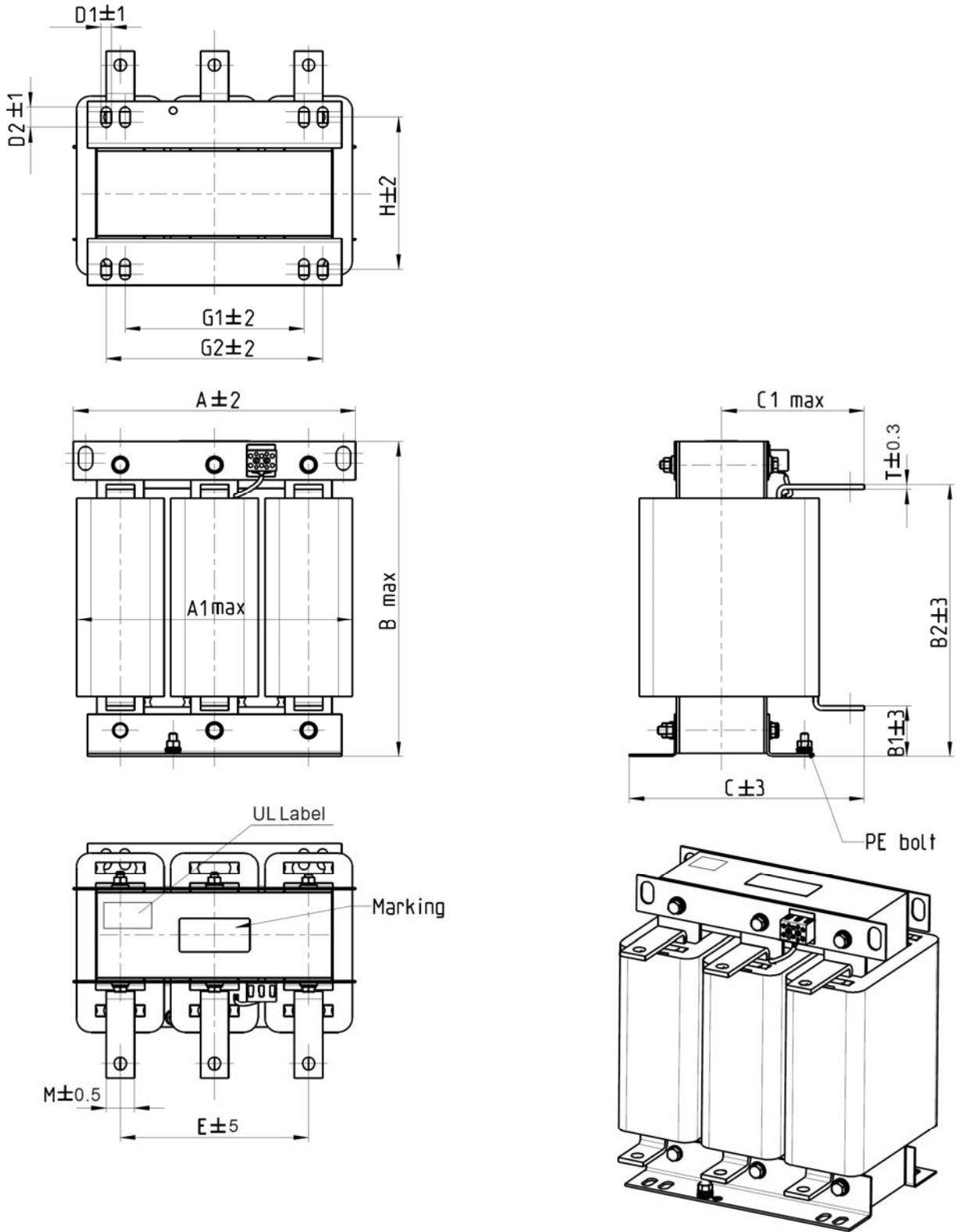

Model	Output AC reactor Delta part #	A	A1	B	B1	B2	C	C1	D1*D2	E	H	M*T
VFD750C23A	DR276AP049	270	260	320	50	265	200	140	10*18	176	106	30*5
VFD900C23A	DR276AP050	270	264	350	50	285	200	140	10*18	176	106	30*5

Table 7-39

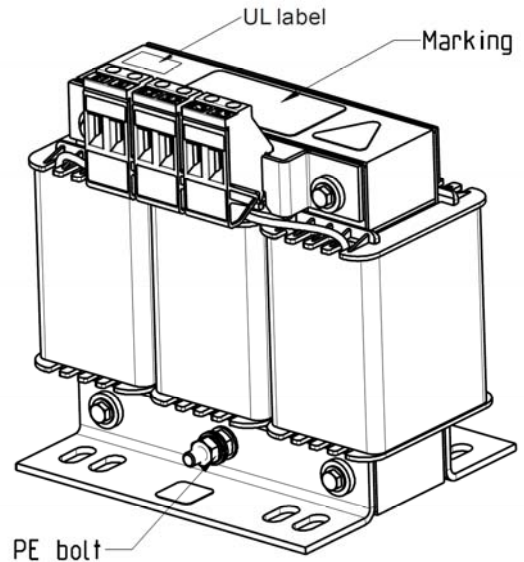
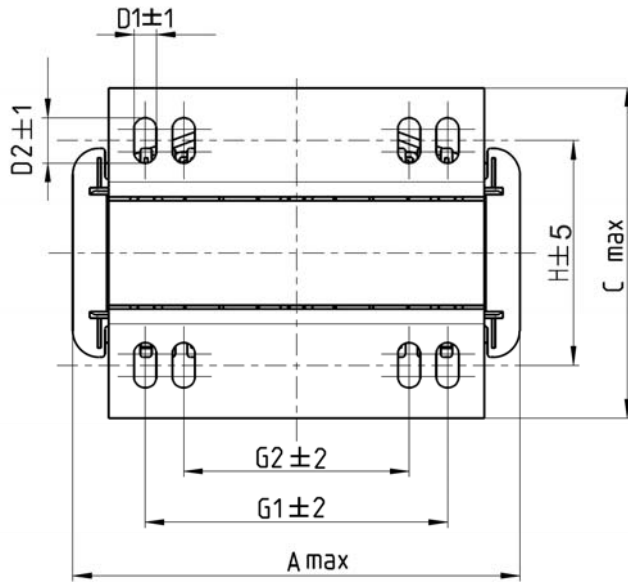

Tightening torque 1.0-1.2 Nm

Tightening torque 0.6-0.8Nm

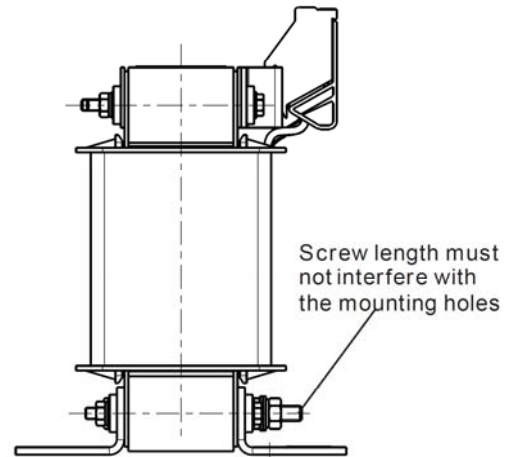
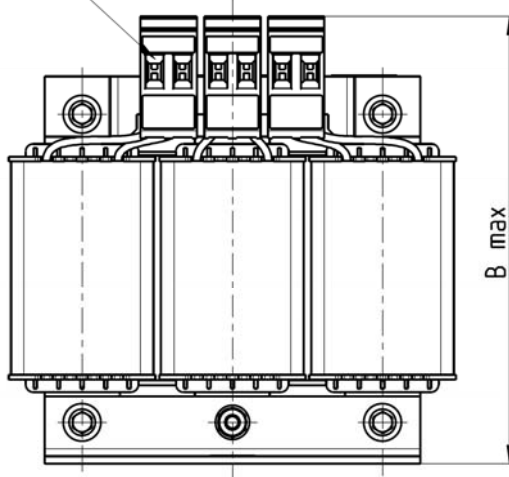

Model	Output AC reactor Delta part #	A	B	C	D1*D2	H	G1	G2	PE
VFD007C43A	DR003A0810	96	115	60	6*9	42	60	40	M4
VFD015C43A	DR004A0607	120	135	88	6*12	60	81	60	M4
VFD022C43A	DR006A0405	120	135	88	6*12	60	81	60	M4
VFD037C43A	DR009A0270	150	160	98	6*12	74	107	75	M4
VFD040C43A	DR010A0231	150	160	112	6*12	88	107	75	M4
VFD055C43A	DR012A0202	150	160	112	6*12	88	107	75	M4
VFD075C43A	DR018A0117	150	160	112	6*12	88	107	75	M4
VFD110C43A	DR024AP881	150	160	112	6*12	88	107	75	M4
VFD150C43A	DR032AP660	180	190	138	6*12	114	122	85	M6

Table 7-40

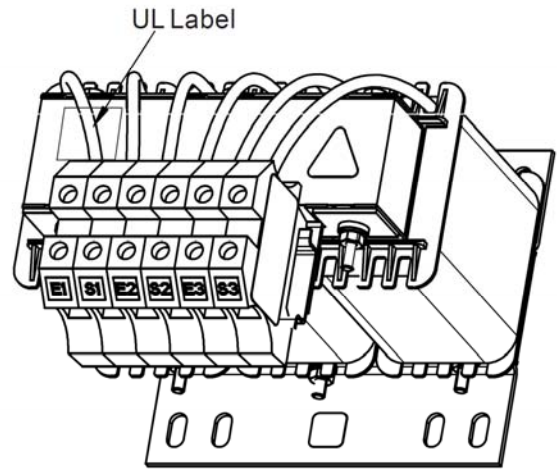
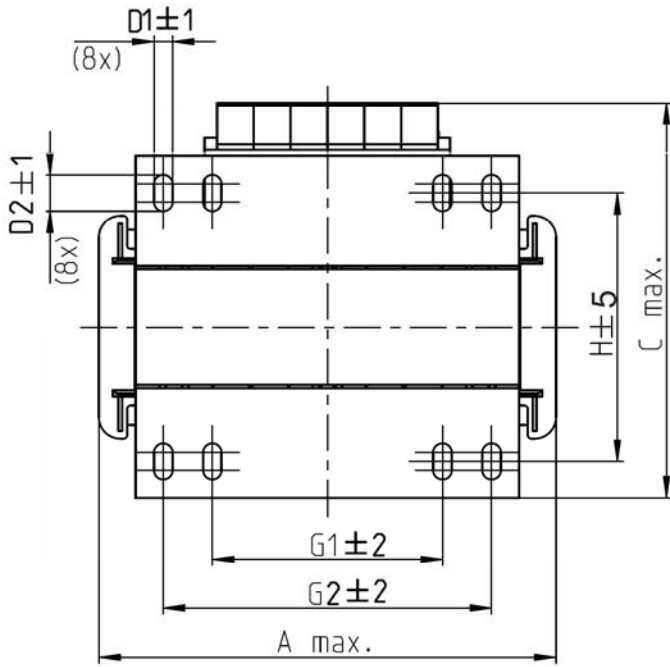

Terminals 16 mm<sup>2</sup>  
Tightening torque 1.2-1.4

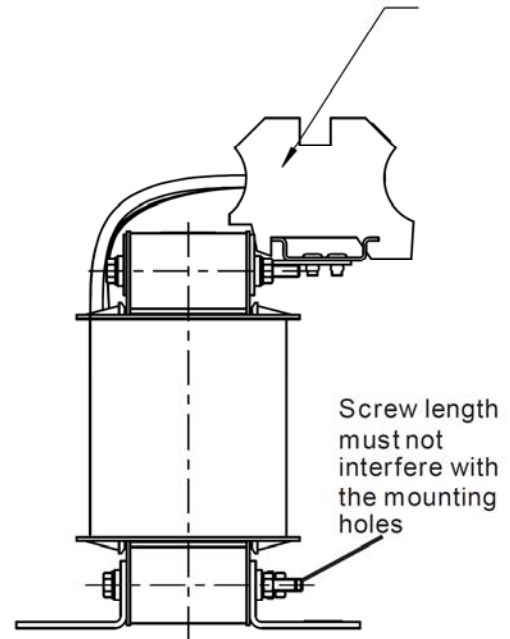
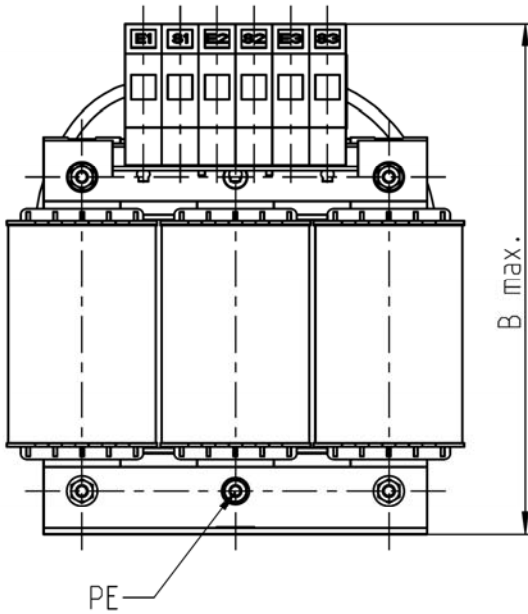

Model	Output AC reactor Delta part #	A	B	C	D1*D2	H	G1	G2	PE
VFD185C43A	DR038AP639	180	205	165	6*12	115	85	122	M4
VFD220C43A	DR045AP541	235	245	150	7*13	85	/	176	M6

Table 7-41



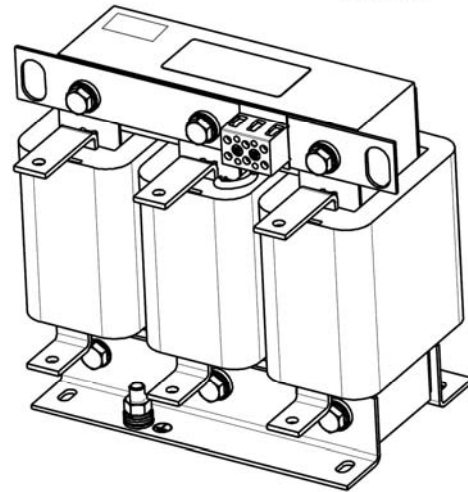
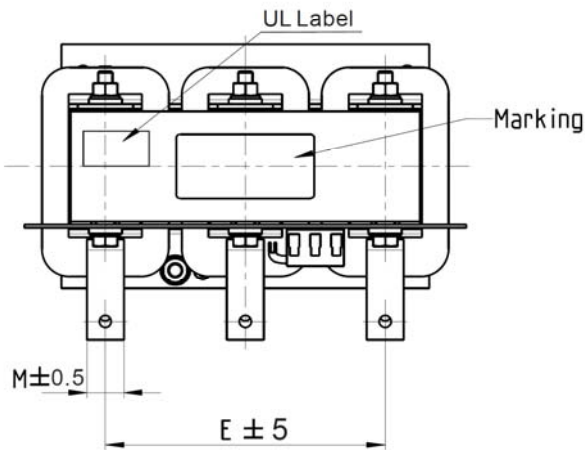
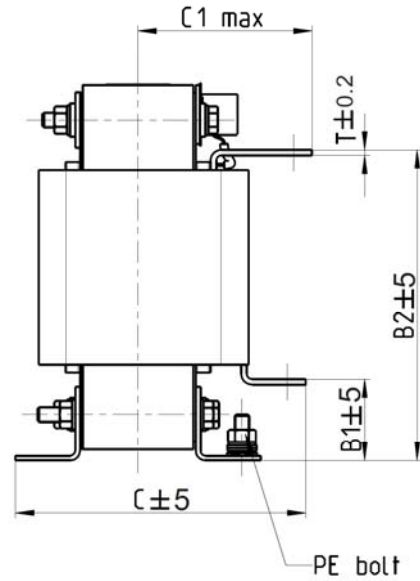
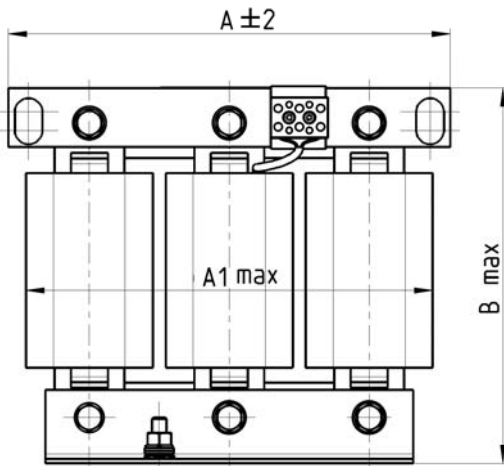
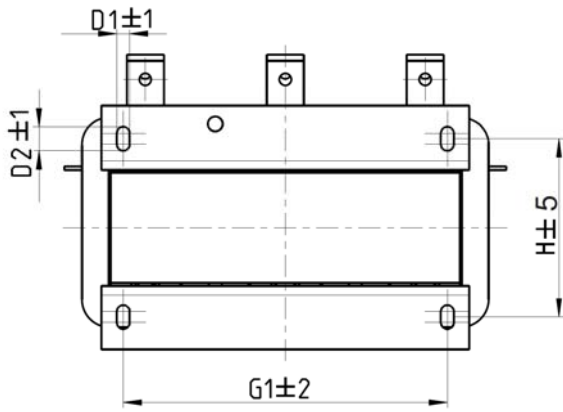

Model	Output AC reactor Delta part #	A	A1	B	B1	B2	C	C1	D1*D2	E	G1	H	M*T
VFD300C43A	DR060AP405	240	228	215	44	170	163	110	7*13	152	176	97	20*3
VFD370C43S/U	DR073AP334	250	235	235	44	186	174	115	11*18	160	190	124	20*3
VFD450C43S/U	DR091AP267	250	240	235	44	186	174	115	11*18	160	190	124	20*3
VFD550C43A	DR110AP221	270	260	245	50	192	175	115	10*18	176	200	106	20*3

Table 7-42

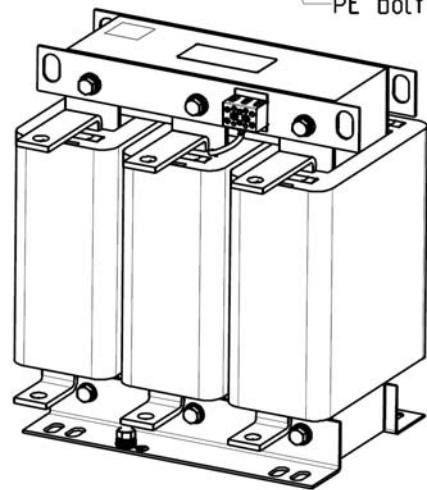
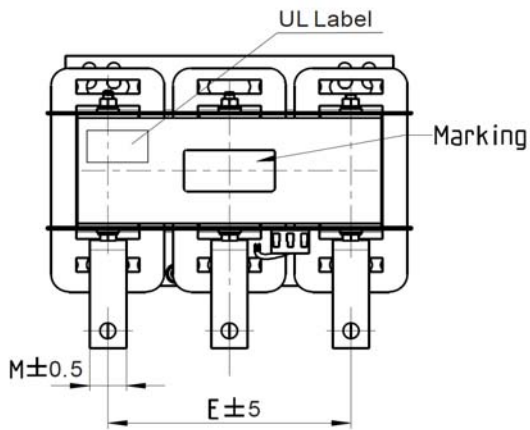
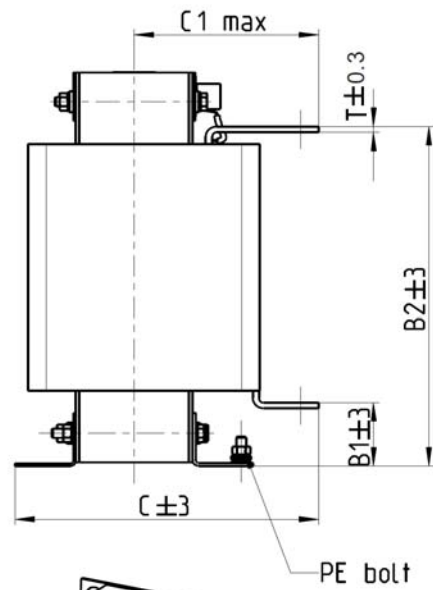
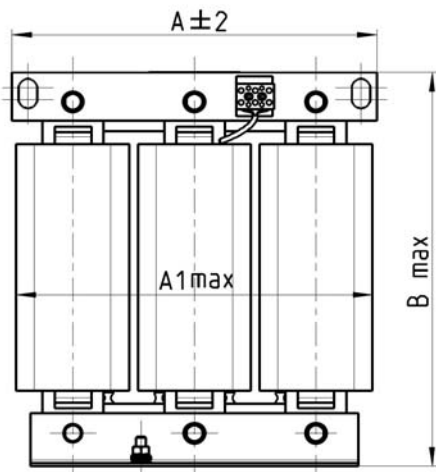
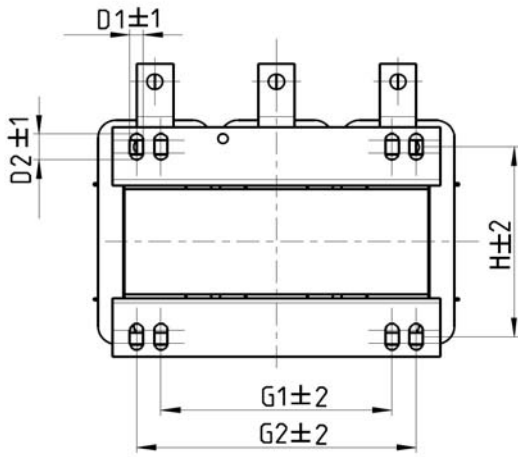

Model	Output AC reactor Delta part #	A	A1	B	B1	B2	C	C1	D1*D2	E	G1	G2	H	M*T
VFD750C43A	DR150LP162	270	264	265	51	208	192	125	10*18	176	200	/	118	30*3
VFD900C43A	DR180LP135	300	295	310	55	246	195	125	11*22	200	230	190	142	30*3
VFD1100C43A	DR220LP110	300	298	310	57	248	210	140	11*22	200	230	190	142	30*5
VFD1320C43A	DR260LP098	300	295	330	56	270	227	140	11*22	200	230	190	160	30*5
VFD1600C43A	DR310LP078	300	298	350	54	288	233	145	11*22	200	230	190	160	30*5
VFD1850C43A	DR370LP066	300	298	350	54	289	268	170	11*22	200	230	190	185	40*5

Table 7-43

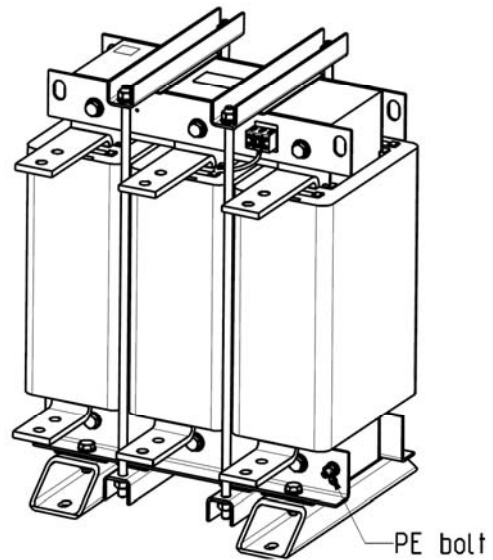
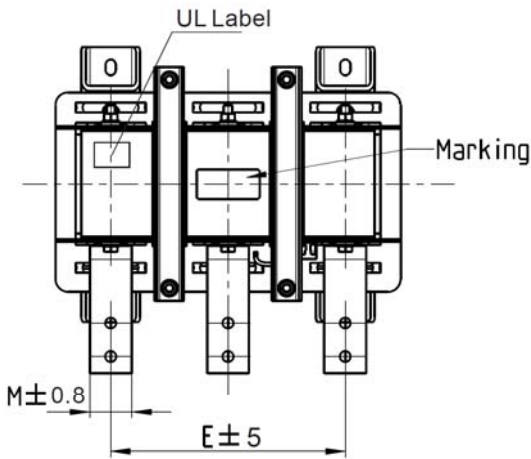
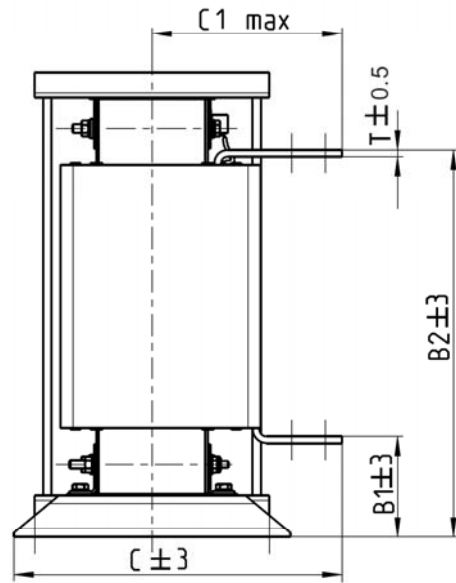
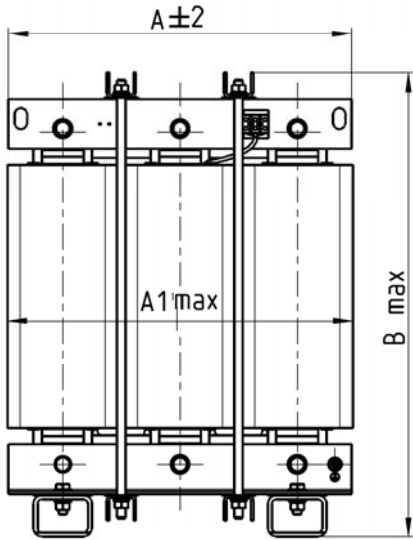
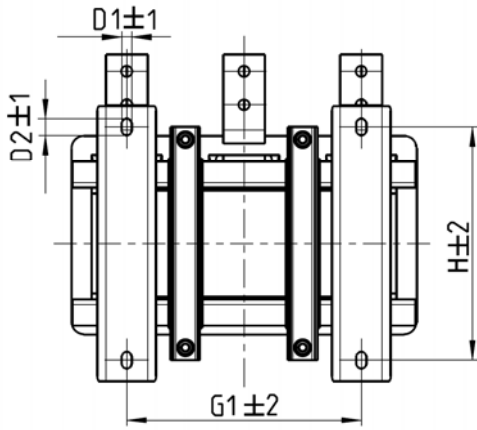

Model	Output AC reactor Delta part #	A	A1	B	B1	B2	C	C1	D1*D2	E	G1	H	M*T
VFD2200C43A	DR460AP054	360	355	510	106	401	346	215	12*20	240	240	240	50*5
VFD2800C43A	DR550AP044	360	355	510	106	401	358	220	12*20	240	240	250	50*5
VFD3150C43A	DR616AP039	360	355	510	110	401	376	230	12*20	240	240	270	50*8
VFD3550C43A	DR683AP036	360	355	510	110	401	396	240	12*20	240	240	290	50*8
VFD4500C43A	DR866AP028	410	418	570	120	464	402	245	12*20	280	280	290	50*8

Table 7-44

## Motor Cable Length

### 1. Leakage current to affect the motor and counter measurement

If the cable length is too long, the parasitic capacitance between cables will enlarge and may increase leakage current. It will activate the protection of over current, and increased leakage current will not ensure the correction of current value in display. The worst case is that AC motor drive may damage.

If more than one motor is connected to the AC motor drive, the total wiring length is the sum of the wiring length from AC motor drive to each motor.

For the 460V series AC motor drive, when an overload relay is installed between the drive and the motor to protect motor from overheating, the connecting cable must be shorter than 50m. However, an overload relay malfunction may still occur. To prevent the malfunction, install an output reactor (optional) to the drive or lower the carrier frequency setting (Pr. 00-17).

### 2. Surge voltage to affect the motor and counter measurement

When motor is driven by a PWM signal of AC motor drive, the motor terminals will experience surge voltages (dv/dt) easily due to power transistors conversion of AC motor drive and cable capacitance. When the motor cable is very long (especially for the 460V series), surge voltages (dv/dt) may reduce insulation quality. To prevent this situation, please follow the rules below:

- a. Use a motor with enhanced insulation
- b. Connect an output reactor (optional) to the output terminals of the AC motor drive
- c. Reduce the motor cable length to suggested value

The suggested motor shielded cable length in the following table complies with IEC 60034-17, which is suitable for the motor with rated voltage under 500 VAC, and the insulation level of peak-to-peak over (including) 1.35kV

230V Model	Rated current (ND) (Arms)	Without AC reactor		With AC reactor	
		Shielded Cable [meter]	Non-shielded cable [meter]	Shielded Cable [meter]	Non-shielded cable [meter]
VFD007C23A	5	50	75	75	115
VFD015C23A	8	50	75	75	115
VFD022C23A	11	50	75	75	115
VFD037C23A	17	50	75	75	115
VFD055C23A	25	50	75	75	115
VFD075C23A	33	100	150	150	225
VFD110C23A	49	100	150	150	225
VFD150C23A	65	100	150	150	225
VFD185C23A	75	100	150	150	225
VFD220C23A	90	100	150	150	225
VFD300C23A/E	120	100	150	150	225
VFD370C23A/E	146	100	150	150	225
VFD450C23A/E	180	150	225	225	325
VFD550C23A/E	215	150	225	225	325
VFD750C23A/E	255	150	225	225	325
VFD900C23A/E	346	150	225	225	325

Table 7-45

460V Model	Rated current (ND) (Arms)	Without AC reactor		With AC reactor	
		Shielded Cable [meter]	Non-shielded cable [meter]	Shielded Cable [meter]	Non-shielded cable [meter]
VFD007C43A	3	50	75	75	115
VFD015C43A	4	50	75	75	115
VFD022C43A	6	50	75	75	115
VFD037C43A	9	50	75	75	115
VFD040C43A	10.5	50	75	75	115
VFD055C43A	12	50	75	75	115
VFD075C43A	18	100	150	150	225
VFD110C43A	24	100	150	150	225
VFD150C43A	32	100	150	150	225
VFD185C43A	38	100	150	150	225
VFD220C43A	45	100	150	150	225
VFD300C43A	60	100	150	150	225
VFD370C43S/U	73	100	150	150	225
VFD450C43S/U	91	150	225	225	325
VFD550C43A/E	110	150	225	225	325
VFD750C43A/E	150	150	225	225	325
VFD900C43A/E	180	150	225	225	325
VFD1100C43A/E	220	150	225	225	325
VFD1320C43A/E	260	150	225	225	325
VFD1600C43A/E	310	150	225	225	325
VFD1850C43A/E	370	150	225	225	325
VFD2200C43A/E	460	150	225	225	325
VFD2800C43A	550	150	225	225	325
VFD3150C43A	616	150	225	225	325
VFD3550C43A	683	150	225	225	325
VFD4500C43A	866	150	225	225	325

Table 7-46

460V EMC Filter built-in model	Rated current (ND) (Arms)	Without AC reactor		With AC reactor	
		Shielded Cable [meter]	Non-shielded cable [meter]	Shielded Cable [meter]	Non-shielded cable [meter]
VFD007C43E	3	30	75	30	115
VFD015C43E	4	30	75	30	115
VFD022C43E	6	30	75	30	115
VFD037C43E	9	30	75	30	115
VFD040C43E	10.5	30	75	30	115
VFD055C43E	12	30	75	30	115
VFD075C43E	18	50	150	50	225
VFD110C43E	24	50	150	50	225
VFD150C43E	32	50	150	50	225
VFD185C43E	38	50	150	50	225
VFD220C43E	45	50	150	50	225
VFD300C43E	60	50	150	50	225

Table 7-47

575V	kW	HP	Rated Current	Without AC reactor		With AC reactor	
Model			Normal Duty (Arms)	Shielded Cable [meter]	Non-shielded Cable [meter]	Shielded Cable [meter]	Non-shielded Cable [meter]
VFD015C53A-21	0.75	1	2.5	35	30	45	20
VFD022C531-21	1.5	2	3.6	35	30	45	20
VFD037C53A-21	2.2	3	5.5	35	30	45	20
VFD055C53A-21	3.7	5	8.2	35	30	45	20
VFD075C53A-21	5.5	7.5	10	35	30	45	20
VFD110C53A-21	7.5	10	15.5	35	30	45	20
VFD150C53A-21	11	15	20	35	30	45	20

Table 7-48

690V	kW	HP	Rated Current	Without AC reactor		With AC reactor	
Model			Normal Duty (Arms)	Shielded Cable [meter]	Non-shielded Cable [meter]	Shielded Cable [meter]	Non-shielded Cable [meter]
VFD185C63B-21	18.5	25	20	20	35	30	45
VFD220C63B-21	22	30	24	20	35	30	45
VFD300C63B-21	30	40	30	20	35	45	60
VFD370C63B-21	37	50	36	20	45	60	75
VFD450C63B-00/21	45	60	45	20	45	60	75
VFD550C63B-00/21	55	75	54	20	45	60	100
VFD750C63B-00/21	75	100	67	20	45	60	100
VFD900C63B-00/21	90	125	86	20	45	75	100
VFD1100C63B-00/21	110	150	104	20	45	75	100
VFD1320C63B-00/21	132	175	125	20	45	75	100
VFD1600C63B-00/21	160	215	150	20	45	90	100
VFD2000C63B-00/21	200	270	180	20	45	90	100
VFD2500C63B-00/21	250	335	220	20	45	90	100
VFD3150C63B-00/21	315	425	290	20	45	90	100
VFD4000C63B-00/21	400	530	350	20	45	90	100
VFD4500C63B-00/21	450	600	385	20	45	90	100
VFD5600C63B-00/21	560	745	465	20	45	75	90
VFD6300C63B-00/21	630	850	675	20	45	75	90

Table 7-49

\* The table above is the suggested cable length of EMC built-in models operating under surge voltage influencing. To pass the noise emission and Electromagnetic interference certification, the cable length should follow chapter 7-7 instruction.

\* 690V output motor cable length needs to comply with IEC 60034-25

Requirements on insulation level of Curve B motor

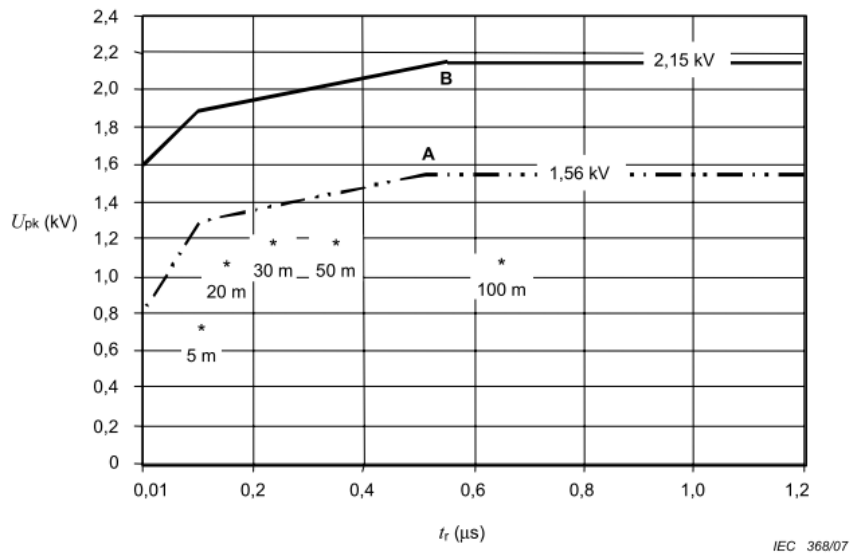

Figure 7-9

**Key**

- A Without filters for motors up to 500 V a.c.
- B Without filters for motors up to 690 V a.c.

\* Examples of measured results at 415 V supply, for different lengths of steel armoured cable

**Figure 14 – Limiting curves of impulse voltage  $U_{pk}$ , measured between two motor phase terminals, as a function of the peak rise time  $t_r$**

The  $t_r$  is defined as:

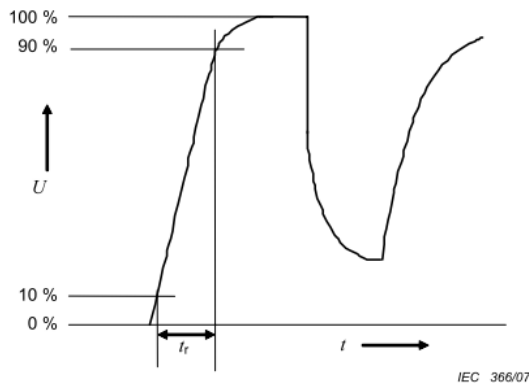

Figure 7-10

**Sine-wave filter**

When there is longer cable length connected between motor drive and motor, the damping will lead to high frequency resonator, and make impedance matching poor to enlarge the voltage reflection. This phenomenon will generate twice-input voltage in motor side, which will easily make motor voltage overshoot to damage insulation.

To prevent this phenomenon, installing sine-wave filter can transform PWM output voltage to smooth and low-ripple sin wave, and motor cable length can longer than 1000 meters.

**Installation**

Sine-wave filter is serially connected between motor drive UVW output side and motor, which is shown as below:

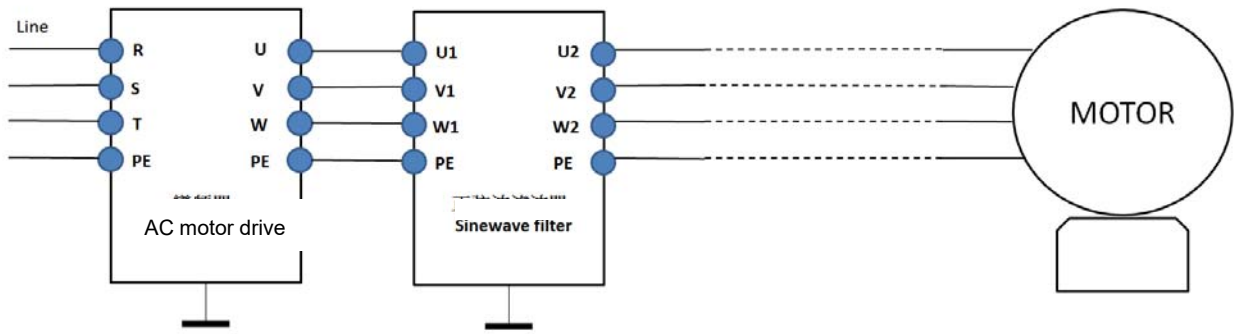

Wiring of non-shielded cable

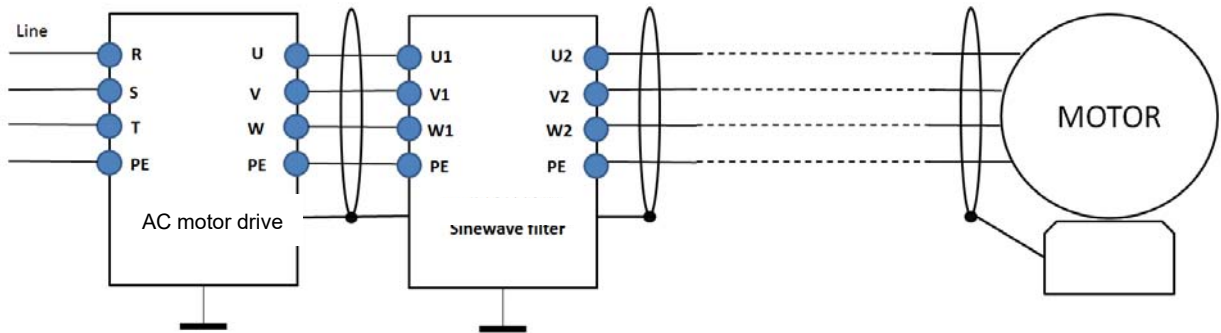

Following table shows the sin-wave filter specification of Delta C2000

200V~230V/ 50~60Hz

kW	HP	Rated current (Arms)	Suggested sine-wave filter part #	Output cable length [m] (Shielded or non-shielded)
0.75	1	5	B84143V0006R227	1000
1.5	2	8	B84143V0011R227	
2.2	3	11		
3.7	5	17	B84143V0025R227	
5.5	7.5	25		
7.5	10	33	B84143V0033R227	
11	15	49	B84143V0050R227	
15	20	65	B84143V0066R227	
18.5	25	75	B84143V0075R227	
22	30	90	B84143V0095R227	
30	40	120	B84143V0132R227	
37	50	146	B84143V0180R227	
45	60	180		
55	75	215	B84143V0250R227	
75	100	255	B84143V0320R227	
90	125	346	Please contact supplier EPCOS	

Table 7-50



380V~460V/ 50~60Hz

kW	HP	Rated current (Arms)	Suggested sine-wave filter part #	Output cable length [m] (Shielded or non-shielded)
0.75	1	3	B84143V0004R227	1000
1.5	2	4		
2.2	3	6	B84143V0006R227	
3.7	5	9	B84143V0011R227	
4	5	10.5		
5.5	7.5	12	B84143V0016R227	
7.5	10	18	B84143V0025R227	
11	15	24		
15	20	32	B84143V0033R227	
18.5	25	38	B84143V0050R227	
22	30	45		
30	40	60	B84143V0066R227	
37	50	73	B84143V0075R227	
45	60	91	B84143V0095R227	
55	75	110	B84143V0132R227	
75	100	150	B84143V0180R227	
90	125	180	B84143V0180R227	1000
110	150	220	B84143V0250R227	
132	175	260	B84143V0320R227	
160	215	310		
185	250	370	Please contact supplier EPCOS	
220	300	460		
280	375	550		
315	420	616		
355	475	683		
450	600	866		

Table 7-51

Sine wave filter part #	Please refer to website: <a href="http://en.tdk.eu/inf/30/db/emc_2014/B84143V_R227.pdf">http://en.tdk.eu/inf/30/db/emc_2014/B84143V_R227.pdf</a>
B84143V0004R227	I <sub>R</sub> :4A, Sine-wave output filters for 3-phase systems
B84143V0006R227	I <sub>R</sub> :6A, Sine-wave output filters for 3-phase systems
B84143V0011R227	I <sub>R</sub> :11A, Sine-wave output filters for 3-phase systems
B84143V0016R227	I <sub>R</sub> :16A, Sine-wave output filters for 3-phase systems
B84143V0025R227	I <sub>R</sub> :25A, Sine-wave output filters for 3-phase systems
B84143V0033R227	I <sub>R</sub> :33A, Sine-wave output filters for 3-phase systems
B84143V0050R227	I <sub>R</sub> :50A, Sine-wave output filters for 3-phase systems
B84143V0066R227	I <sub>R</sub> :66A, Sine-wave output filters for 3-phase systems

Sine wave filter part #	Please refer to website: <a href="http://en.tdk.eu/inf/30/db/emc_2014/B84143V_R227.pdf">http://en.tdk.eu/inf/30/db/emc_2014/B84143V_R227.pdf</a>
B84143V0075R227	I <sub>R</sub> :75A, Sine-wave output filters for 3-phase systems
B84143V0095R227	I <sub>R</sub> :95A, Sine-wave output filters for 3-phase systems
B84143V0132R227	I <sub>R</sub> :132A, Sine-wave output filters for 3-phase systems
B84143V0180R227	I <sub>R</sub> :180A, Sine-wave output filters for 3-phase systems
B84143V0250R227	I <sub>R</sub> :250A, Sine-wave output filters for 3-phase systems
B84143V0320R227	I <sub>R</sub> :320A, Sine-wave output filters for 3-phase systems

Table 7-52

### 7-5 Zero Phase Reactors

Reactor model (Note)	Recommended Wire Size		Wiring Method	Qty	Corresponding motor drives
RF008X00A	≤ 8 AWG	≤ 8.37 mm <sup>2</sup>	Diagram A	1C*3 or 4C*1	VFD007C23A; VFD015C23A; VFD022C23A; VFD037C23A; VFD007C43A; VFD015C43A; VFD022C43A; VFD037C43A; VFD040C43A; VFD055C43A; VFD015C53A-21; VFD022C53A-21; VFD037C53A-21; VFD055C53A-21; VFD075C53A-21, VFD110C53A-21; VFD150C53A-21
T60006L2040W453	≤ 8 AWG	≤ 8.37 mm <sup>2</sup>	Diagram B		
RF004X00A	≤ 1 AWG	≤ 42.41 mm <sup>2</sup>	Diagram A	1C*3 or 4C*1	VFD055C23A; VFD075C23A; VFD110C23A; VFD110C43A; VFD150C43A; VFD075C43A; VFD110C43A; VFD150C43A
T60006L2050W565	≤ 1 AWG	≤ 42.41mm <sup>2</sup>	Diagram B		
RF002X00A	≤ 600MCM	≤ 304 mm <sup>2</sup>	Diagram A	1C*3 or 4C*1	VFD150C23A; VFD185C23A; VFD220C23A; VFD300C23A; VFD370C23A; VFD450C23A; VFD550C23A; VFD750C23A; VFD900C23A; VFD185C43A; VFD220C43A; VFD300C43A; VFD550C43A; VFD750C43A; VFD900C43A; VFD1100C43A; VFD1320C43A; VFD1600C43A; VFD185C63B-21; VFD220C63B-21; VFD300C63B-21; VFD370C63B-21; VFD450C63B-XX; VFD550C63B-XX
T60006L2050W565	≤ 600MCM	≤ 304 mm <sup>2</sup>	Diagram B		
RF300X00A	≤ 300 MCM	≤ 152 mm <sup>2</sup>	Diagram A	1C*12 or 4C*3	VFD1850C43A; VFD2200C43A; VFD2800C43A; VFD3150C43A; VFD3550C43A; VFD4500C43A; VFD750C63B-XX; VFD900C63B-XX; VFD1100C63B-XX; VFD1320C63B-XX; VFD1600C63B-XX; VFD2000C63B-XX; VFD2500C63B-XX; VFD3150C63B-XX; VFD4000C63B-XX; VFD4500C63B-XX; VFD5600C63B-XX; VFD6300C63B-XX;

Note 1: \*600V insulated cable wire

Note 2: Above table only considers the motor wire size

Note 3: For max. wiring quantity, please refer to Chapter 5 Main Circuit Terminal.

Table 7-53

Diagram A

Please put all wires through at least one core without winding.

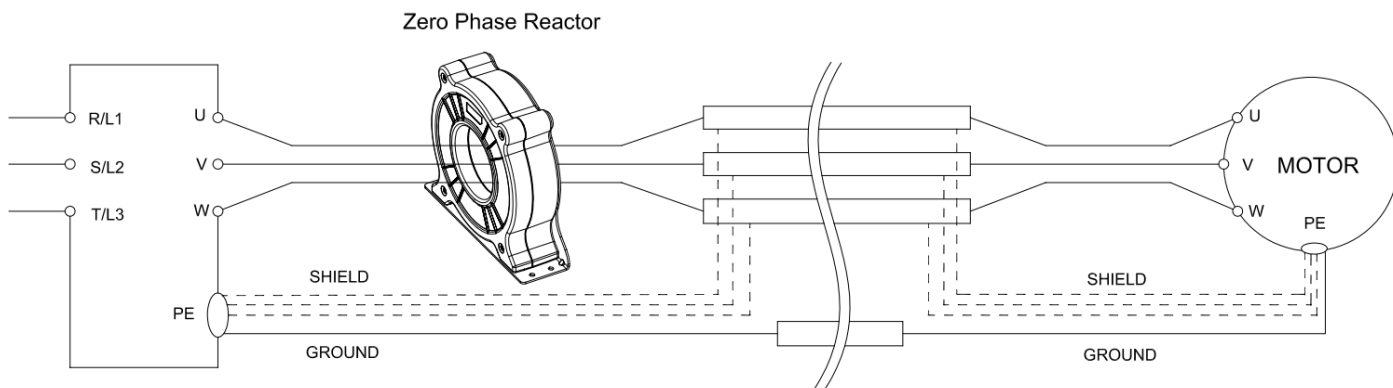

Diagram B

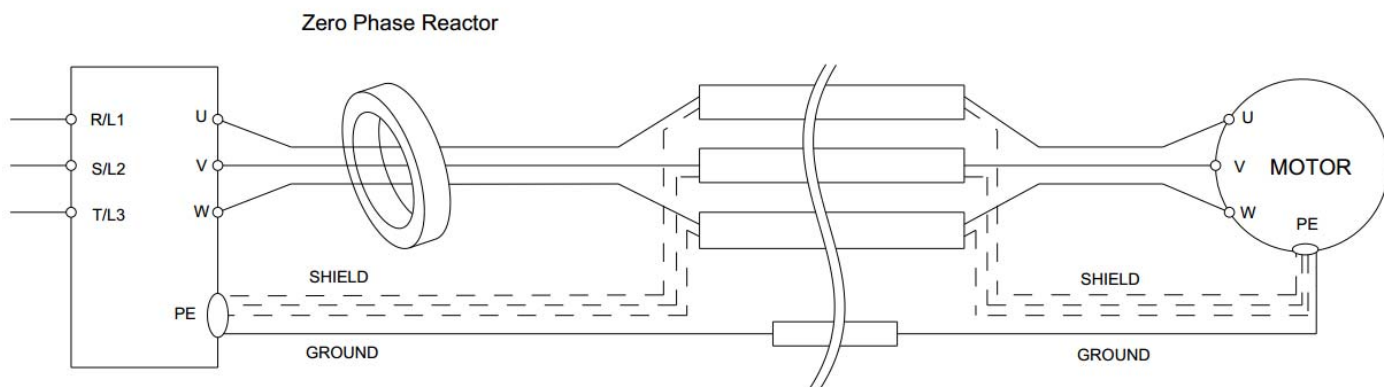

Diagram C

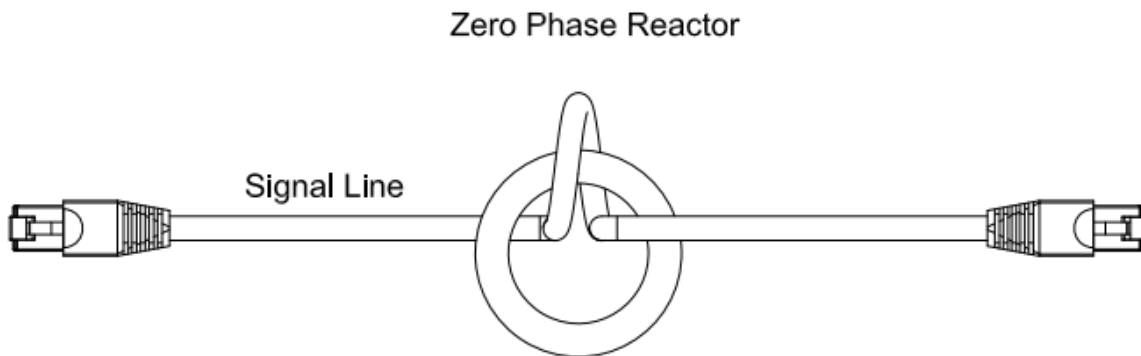

Diagram D

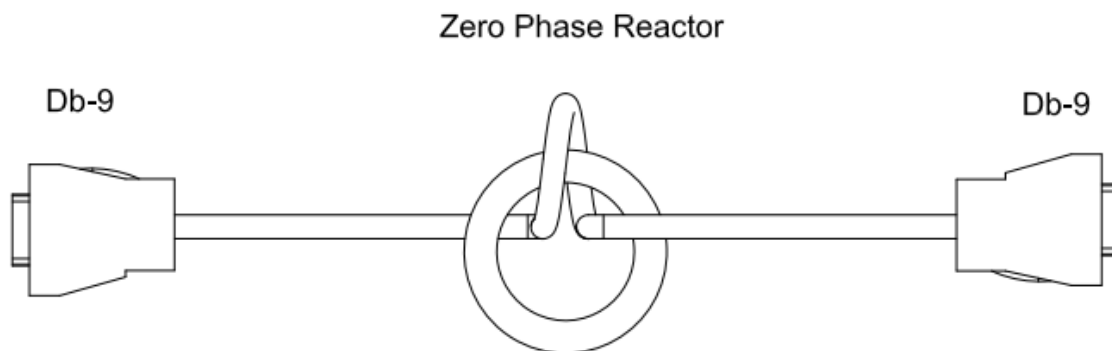
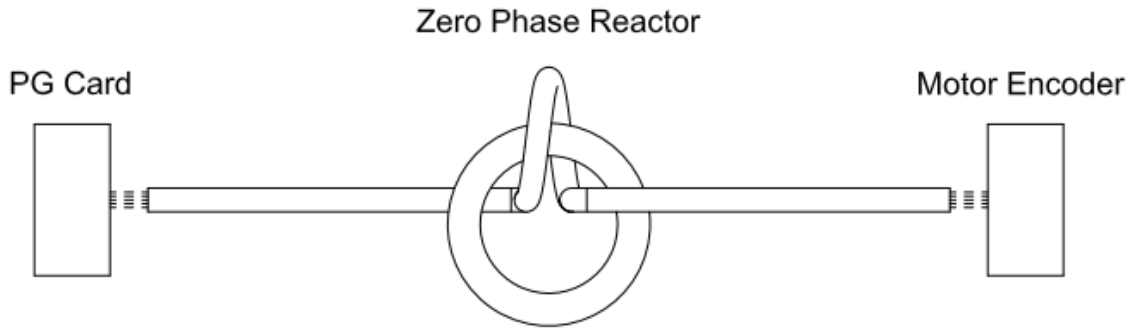

Diagram E



**Note 1:** The table above gives approximate wire size for the zero phase reactors but the selection is ultimately governed by the type and diameter of cable fitted, i.e. the cable must fit through the center hole of zero phase reactors.

**Note 2:** Only the phase conductors should pass through, not the earth core or screen.

**Note 3:** For the zero phase reactor used for signal cables, it is recommended to install near to the driver and well fixed, as to prevent vibration and pulling of the cable.

Model*	Recommended wire size	Wiring method	Q'ty	Applicable cables
T60006L2050W565	≤1 AWG	Diagram D	1	D-sub
T60006L2040W453	≤8 AWG	Diagram C	1	Category 5e shielding \ Shielded twisted pair cable \ CAN standard cable (TAP-CB05, TAP-CB10)
T60004L2025W622	≤10AWG	Diagram E	1	PG card signal cable
T60004L2016W620	≤12AWG	Diagram E	1	PG card signal cable

Table 7-54

Note 1: \*The table above is for reference only, please choose the zero phase reactor based on the actual wire size that you are using.

Note 2: Some of the cables are recommended to choose bigger zero phase reactor due to its corresponded mechanical size.

Recommended max. motor wire size of zero phase reactor (included LUG width and temp. tolerance of motor cable)

Zero phase reactor	Available max. wire size/ LUG width	Available max. AGW (1C*3)		Available max. AWG (4C*1)	
		75C	90C	75C	90C
RF008X00A	13MM	3AWG	1AWG	3AWG	1AWG
RF004X00A	16MM	1AWG	2/0AWG	1AWG	1/0AWG
RF002X00A	36MM	600MCM	600MCM	1AWG	1/0AWG
RF300X00A	73MM	650MCM	650MCM	300MCM	300MCM
T60006L2040W453	11MM	9AWG	4AWG	6AWG	6AWG
T60006L2050W565	16MM	1AWG	2/0AWG	1AWG	1/0AWG
T60006L2160V066	57MM	600MCM	600MCM	300MCM	300MCM

Table 7-55

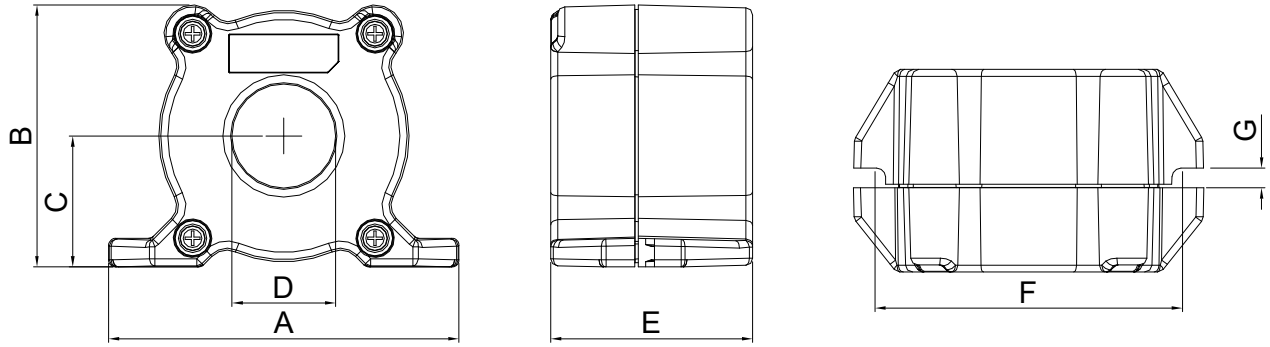

Unit: mm [inch]

Model	A	B	C	D	E	F	G(Ø)	Torque
RF008X00A	98 [3.858]	73 [2.874]	36.5 [1.437]	29 [1.142]	56.5 [2.224]	86 [3.386]	5.5 [0.217]	< 10kgf/cm <sup>2</sup>
RF004X00A	110 [4.331]	87.5 [3.445]	43.5 [1.713]	36 [1.417]	53 [2.087]	96 [3.780]	5.5 [0.217]	< 10kgf/cm <sup>2</sup>

Table 7-56

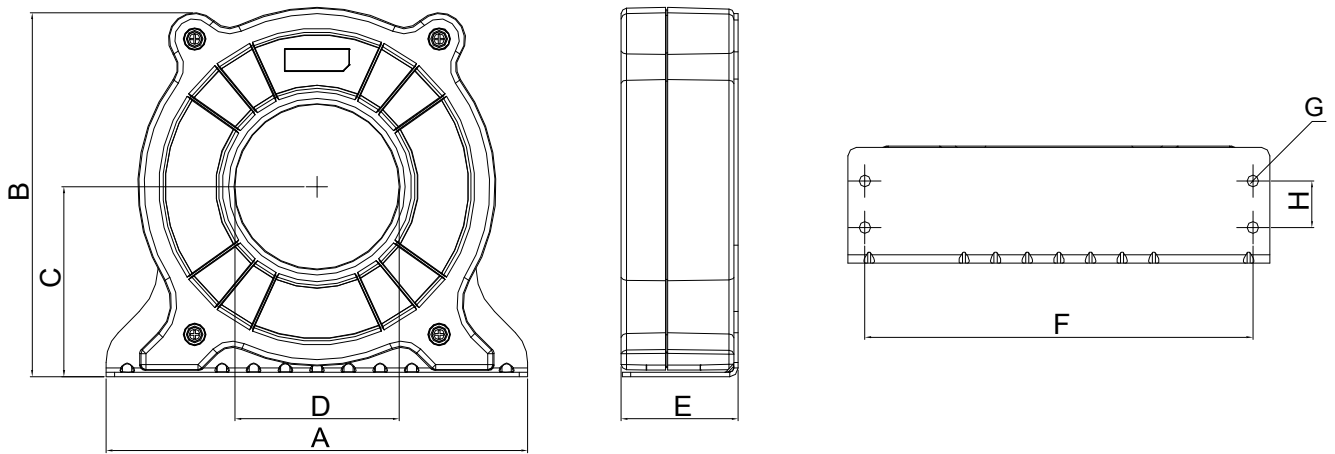

Unit: mm [inch]

Model	A	B	C	D	E	F	G(Ø)	H	Torque
RF002X00A	200 [7.874]	172.5 [6.791]	90 [3.543]	78 [3.071]	55.5 [2.185]	184 [7.244]	5.5 [0.217]	22 [0.866]	<45kgf/cm <sup>2</sup>

Table 7-57

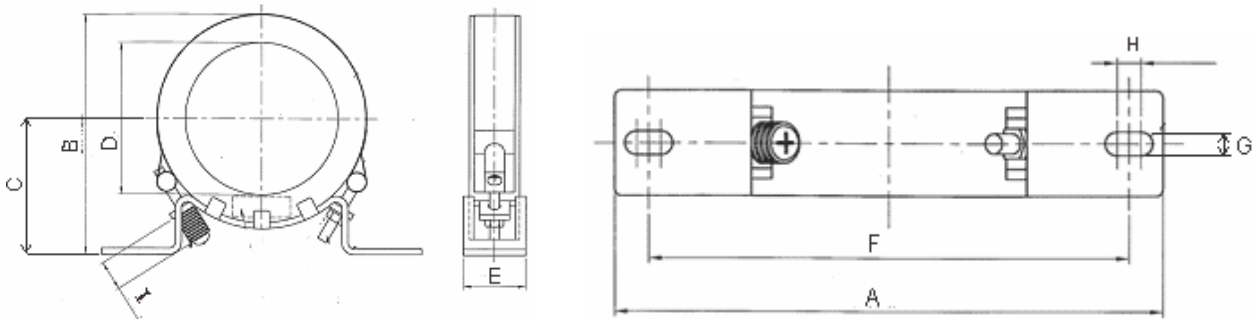

Unit: mm [inch]

Model	A	B	C	D	E	F	G(Ø)	H	I
RF300X00A	241 [9.488]	217 [8.543]	114 [4.488]	155 [6.102]	42 [1.654]	220 [8.661]	6.5 [0.256]	7.0 [0.276]	20 [0.787]

Table 7-58

### Magnetic Ring

Model number: T60006-L2040-W453

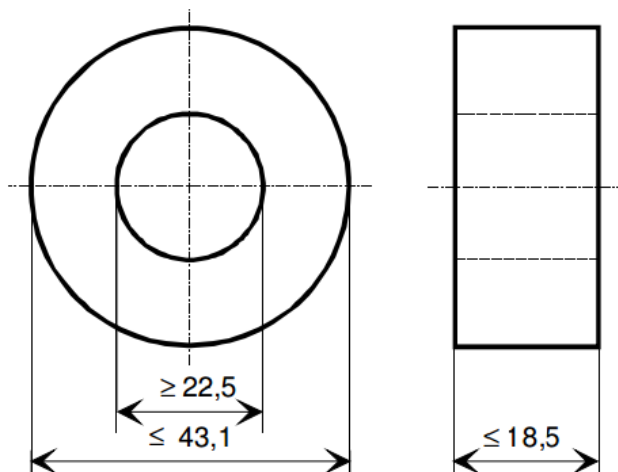

Model number: T60006-L2050-W565

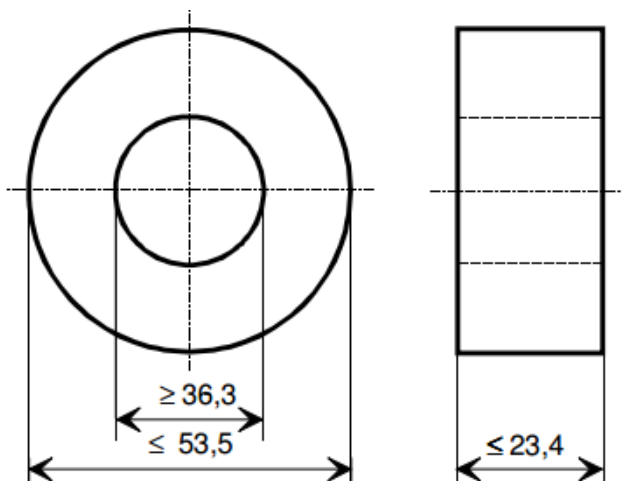

Model number: T60006-L2160-V066

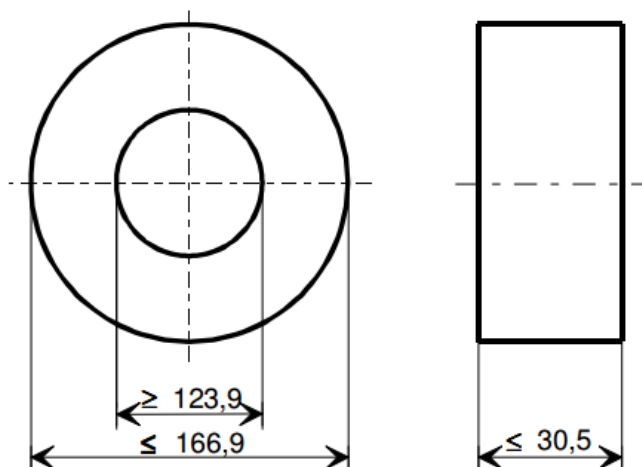

Model number: T60004-L2016-W620

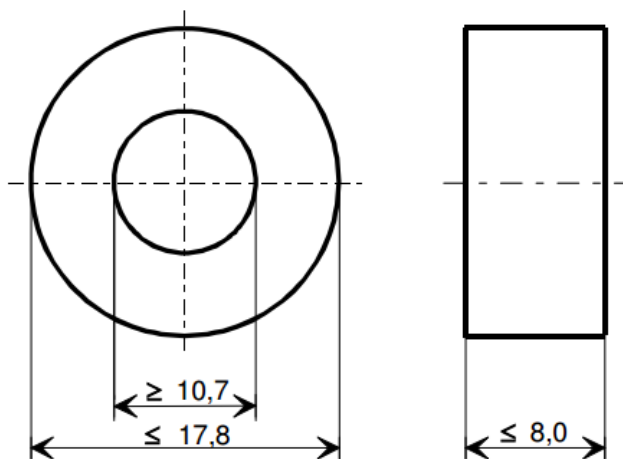

Model number: T60004-L2025-W622

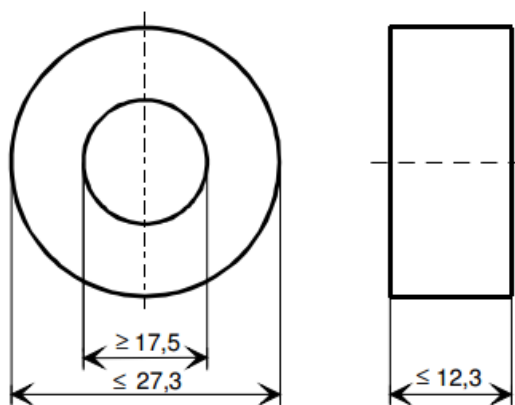



## 7-6 EMC Filter

Following table is the external EMC filter of C2000 series, user can choose corresponding zero phase reactor and suitable shielded cable length in accord to required noise emission and electromagnetic interference level to have the best configuration to suppress the electromagnetic interference. When the application does not consider RE and only needs CE to comply with C2 or C1, there is no need to install zero phase reactor in input side.

230V model

C2000			Filter model name	Zero phase reactor		Fc	Conducted Emission		Radiation Emission
Frame	Model	Rated input current [A]		Input side (R/S/T)	Output side (U/V/W)		Output shielded cable length		EN61800-3
							C2	C1	
A	VFD007C23A	6.4	EMF021A23A	RF008X00A or T60006L2040W453	RF008X00A or T60006L2040W453	≤ 8kHz	100m	50m	C2
	VFD015C23A	12							
	VFD022C23A	16							
	VFD037C23A	20							
B	VFD055C23A	28	EMF056A23A	RF004X00A or T60006L2050W565	RF004X00A or T60006L2050W565	≤ 8kHz	100m	50m	C2
	VFD075C23A	36							
	VFD110C23A	52							
C	VFD150C23A	72	KMF3100A	RF002X00A or T60006L2160V066	RF002X00A or T60006L2160V066	≤ 6kHz	100m	50m	C2
	VFD185C23A	83							
	VFD220C23A	99							
D	VFD300C23A	124	B84143D0150R127	N/A	RF002X00A or T60006L2160V066	≤ 6kHz	100m	50m	C2
	VFD370C23A	143							
E	VFD450C23A	171	B84143B0250S020	N/A	RF300X00A or T60006L2160V066	≤ 4kHz	100m	50m	C2
	VFD550C23A	206							
	VFD750C23A	245							
F	VFD900C23A	331	B84143B0400S020	N/A	RF300X00A or T60006L2160V066	≤ 4kHz	100m	50m	C2

Table 7-59

## 460V model

C2000			Filter model name (U/V/W)	Zero phase reactor		Fc	Conducted Emission		Radiation Emission
Frame	Model	Rated input current [A]		Input side (R/S/T)	Output side (U/V/W)		Output shielded cable length		EN61800-3
							C2	C1	
A	VFD007C43A	4.3	EMF014A43A	RF008X00A or T60006L2040W453	RF008X00A or T60006L2040W453	≤ 8kHz	100m	50m	C2
	VFD015C43A	5.9							
	VFD022C43A	8.7							
	VFD037C43A	14	EMF018A43A						
	VFD040C43A	15.5							
	VFD055C43A	17							
B	VFD075C43A	20	EMF039A43A	RF004X00A or T60006L2050W565	RF004X00A or T60006L2050W565				
	VFD110C43A	26							
	VFD150C43A	35							
C	VFD185C43A	40	KMF370A	RF002X00A or T60006L2160V066	RF002X00A or T60006L2160V066	≤ 6kHz	100m	50m	C2
	VFD220C43A	47							
	VFD300C43A	63							
D0	VFD370C43S/U	74	B84143D0150R127	N/A	RF002X00A or T60006L2160V066	≤ 6kHz	100m	50m	C2
	VFD450C43S/U	101							
D	VFD550C43A	114	B84143D0150R127	N/A	RF002X00A or T60006L2160V066	≤ 6kHz	100m	50m	C2
		VFD750C43A							
E	VFD900C43A	167	B84143D0200R127	N/A	RF300X00A or T60006L2160V066	≤ 4kHz	100m	50m	C2
		VFD1100C43A							
F	VFD1320C43A	240	MIF3400B	N/A	RF300X00A or T60006L2160V066	≤ 4kHz	100m	50m	C2
		VFD1600C43A							
G	VFD1850C43A	380	MIF3800	N/A	RF300X00A or T60006L2160V066	≤ 4kHz	100m	50m	C2
		VFD2200C43A							
H	VFD2800C43A	494	B84143B1000S020	N/A	RF300X00A or T60006L2160V066	≤ 4kHz	100m	50m	C2
	VFD3150C43A	555							
	VFD3550C43A	625							
	VFD4500C43A	866							

Table 7-60

C2000			Filter model name (U/V/W)	Zero phase reactor		Carrier Frequency	Conducted Emission		Radiation Emission
Frame	Model	Rated Input Current [A]		Input side (R/S/T)	Output side (U/V/W)		Output shielded cable length		EN61800-3
							EN618000-3 C2		
D0	VFD370C43S/U	74	B84143B0120R110	N/A	RF300X00A or T60006L2160V066	≤6kHz	25m		*C2
		VFD450C43S/U							
D	VFD550C43A	114	B84143B0180S020	N/A	RF300X00A or T60006L2160V066	≤4kHz	13m		*C3
		VFD750C43A							
E	VFD900C43A	167	B84143B0250S020	N/A	RF300X00A or T60006L2160V066	≤4kHz	13m		C2
		VFD1100C43A							
F	VFD1320C43A	240	B84143B0400S020	N/A	RF300X00A or T60006L2160V066	≤4kHz	13m		C2
		VFD1600C43A							
G	VFD1850C43A	380	B84143B0600S020	N/A	RF300X00A or T60006L2160V066	≤4kHz	13m		C2
		VFD2200C43A							
H	VFD2800C43A	494	B84143B1000S020	N/A	RF300X00A or T60006L2160V066	≤2kHz	13m		*C3
	VFD3150C43A	555							
	VFD3550C43A	625							
	VFD4500C43A	866							

Table 7-61

\*For Radiated Emission, the drive needs to be placed inside a cabinet.

C2000			Filter model name (U/V/W)	Zero phase reactor		Carrier Frequency	Conducted Emission	Radiation Emission
Frame	Model	Rated Input Current [A]		Input side (R/S/T)	Output side (U/V/W)		Output shielded cable length	EN61800-3
							EN618000-3 C2	
D0	VFD370C43S/U	74	B84143A0120R105	N/A	N/A	≤6kHz	150m	C3
	VFD450C43S/U	101						
D	VFD550C43A	114	B84143B0180S080					*C3
	VFD750C43A	157						
E	VFD900C43A	167	B84143B0250S080			C3		
	VFD1100C43A	207						
F	VFD1320C43A	240	B84143B0400S080					
	VFD1600C43A	300						
G	VFD1850C43A	380	B84143B0600S080					
	VFD2200C43A	400						
H	VFD2800C43A	494	B84143B1000S080	100m				
	VFD3150C43A	555						
	VFD3550C43A	625						
	VFD4500C43A	866						

\*For Radiated Emission, the drive needs to be placed inside a cabinet.

Table 7-62

690V models

Frame	Model	Filter model name	Zero phase reactor	conducted and radiated emission						
				C2-motor cable length-50m			C3-motor cable length-100m			
				Location of zero phase reactor (Refer to below figure shown)						
				1*	2*	3*	1*	2*	3*	
A	VFD015C53A-21	EMF014A63A	T60006L2040W453			1			1	
	VFD022C53A-21					1		1		
	VFD037C53A-21					1		1		
B	VFD055C53A-21	EMF027A63A			1	1		1	1	
	VFD075C53A-21				1	1		1	1	
	VFD110C53A-21				1	1		1	1	
	VFD150C53A-21				1	1		1	1	
C	VFD185C63B-21	B84143A0050R021		T60006L2050W565						
	VFD220C63B-21									
	VFD300C63B-21									
	VFD370C63B-21									
D	VFD450C63B-00	B84143A0080R021							1	2
	VFD550C63B-00						1	2		
	VFD450C63B-21						1	2		
	VFD550C63B-21						1	2		
E	VFD750C63B-00	B84143B0150S021								
	VFD900C63B-00									
	VFD1100C63B-00									
	VFD1320C63B-00									
	VFD750C63B-21									
	VFD900C63B-21									
	VFD1100C63B-21									
F	VFD1600C63B-00	B84143B0250S021	T60006L2160V066							
	VFD2000C63B-00									
	VFD1600C63B-21									
	VFD2000C63B-21									
G	VFD2500C63B-00	B84143B0400S021								
	VFD3150C63B-00									
	VFD2500C63B-21									
H	VFD4000C63B-00	B84143B1000S021						1	1	
	VFD4500C63B-00						1	1		
	VFD5600C63B-00						1	1		
	VFD6300C63B-00						1	1		
	VFD4000C63B-21						1	1		
	VFD4500C63B-21					1	1			
	VFD5600C63B-21					1	1			
	VFD6300C63B-21					1	1			

※ The number represents quantity of zero phase reactor, all the motor cable are shielded cables.

Table 7-63

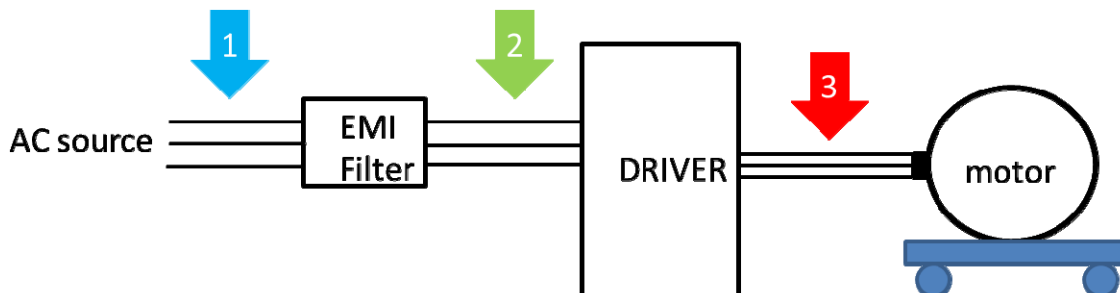

EMC Filter Dimension

EMC filter model name: EMF021A23A, EMF014A43A

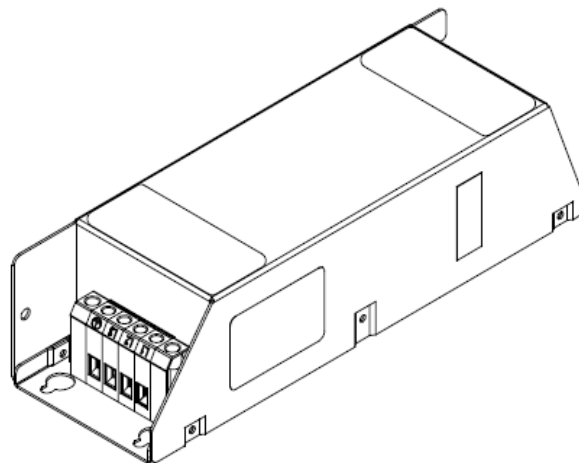
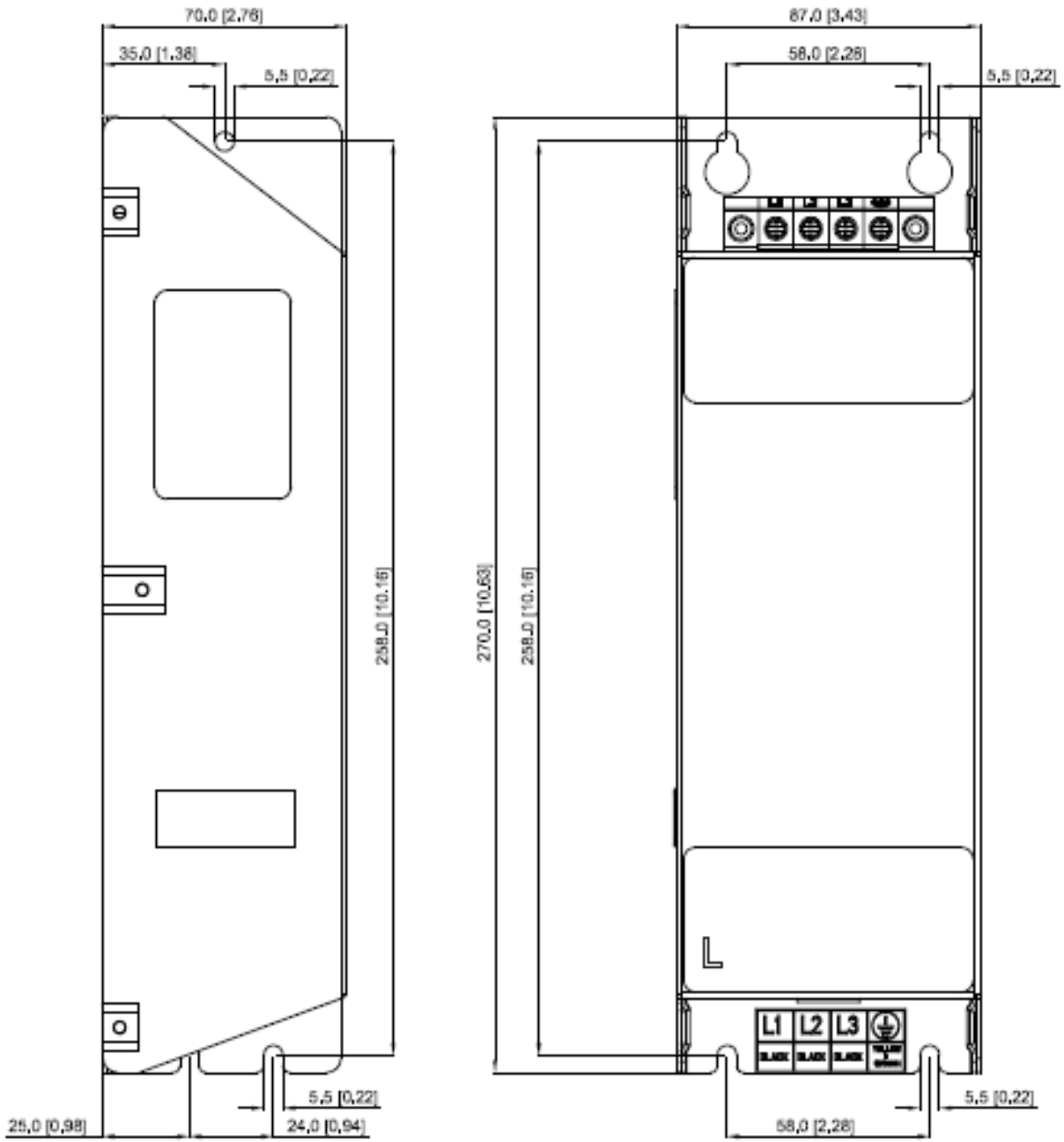

EMC filter model name: EMF018A43A

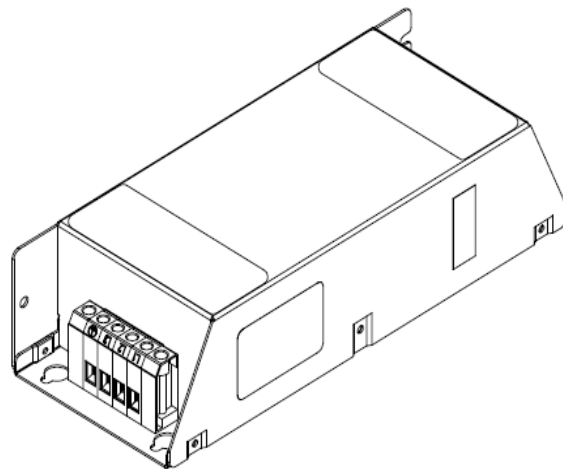
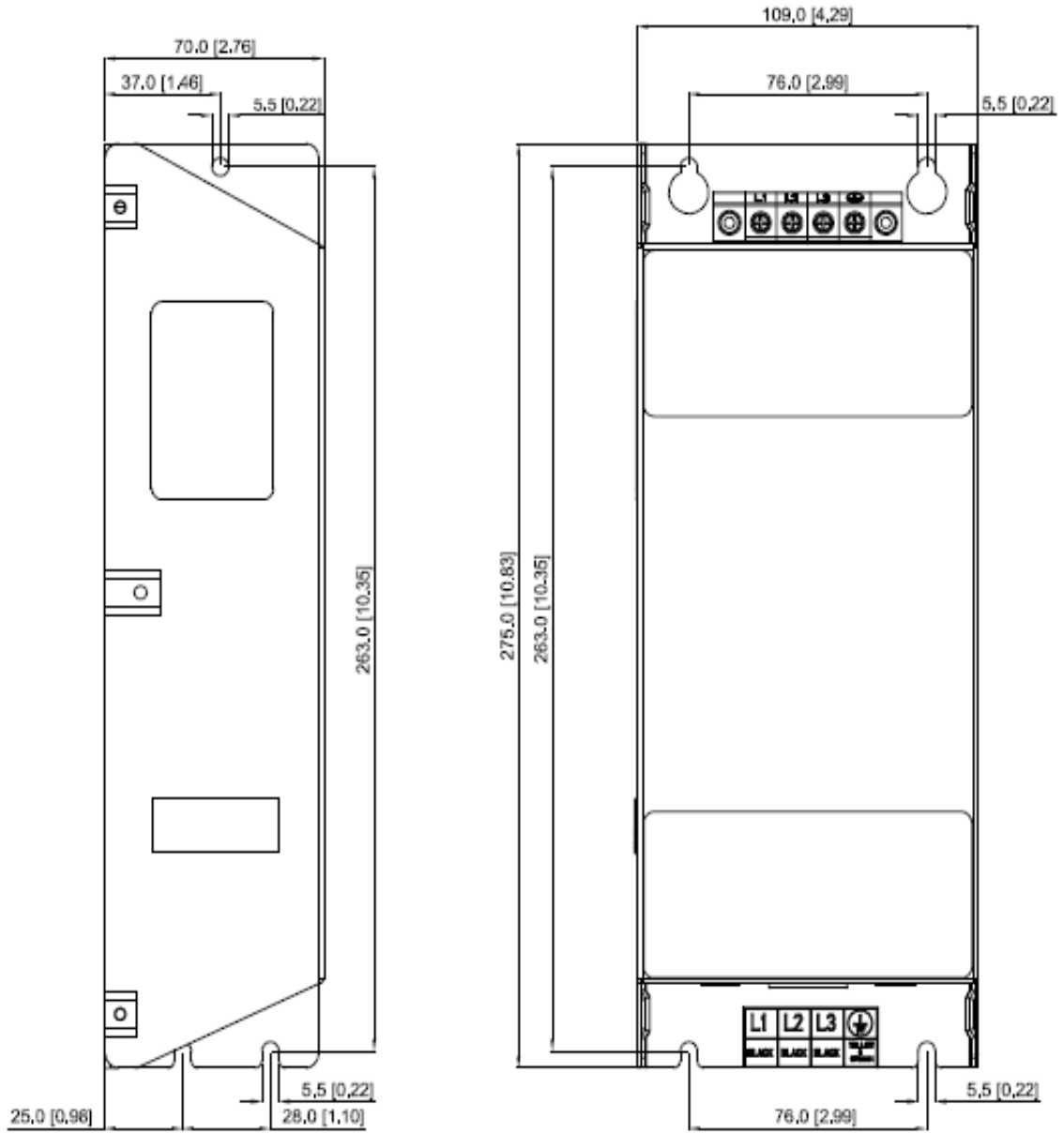

EMC filter model name: EMF056A23A, EMF039A43A

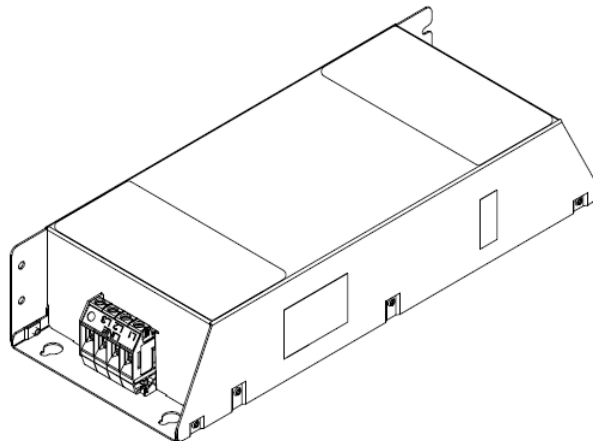
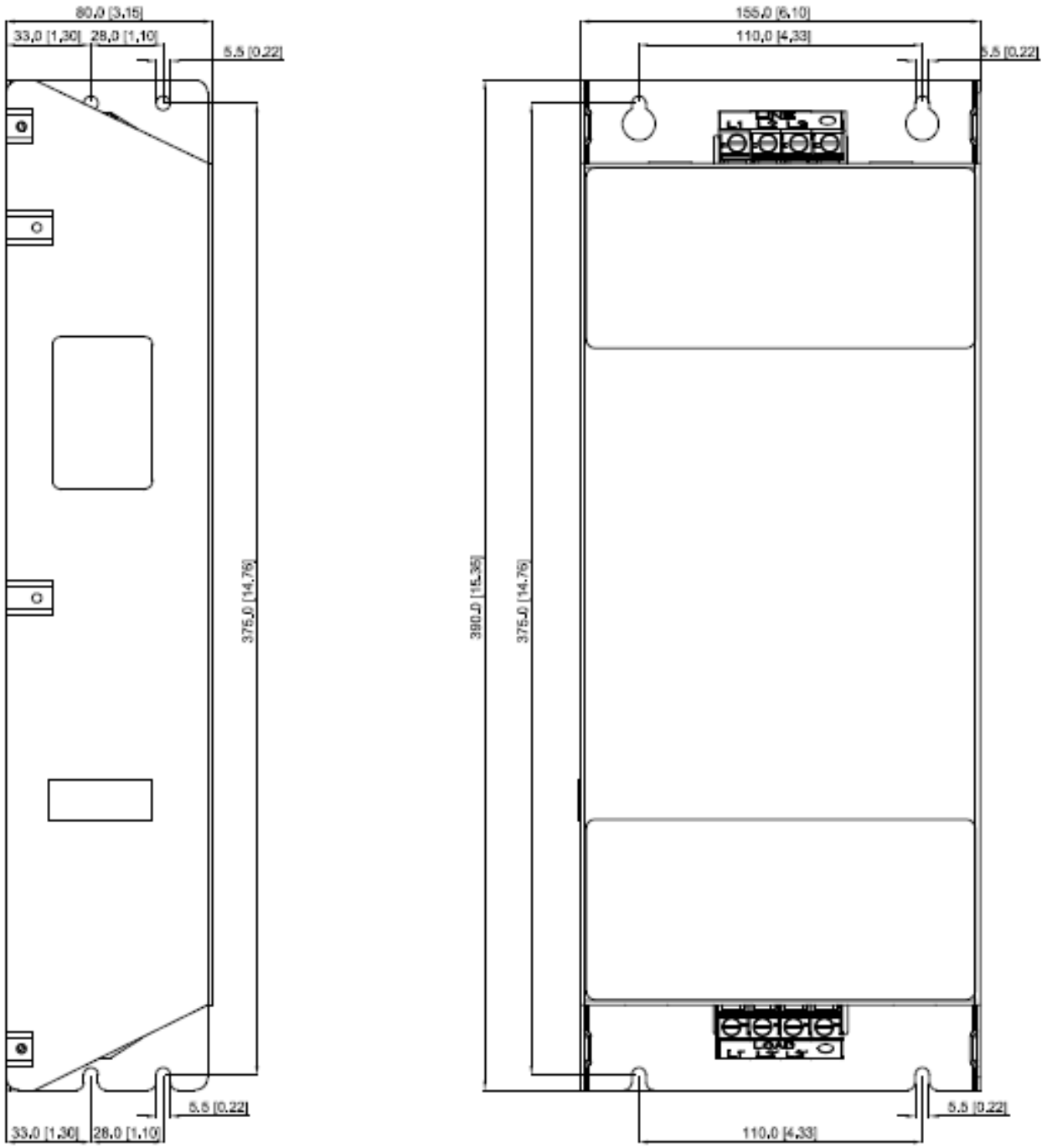

EMC filter model name: KMF370A, KMF3100A

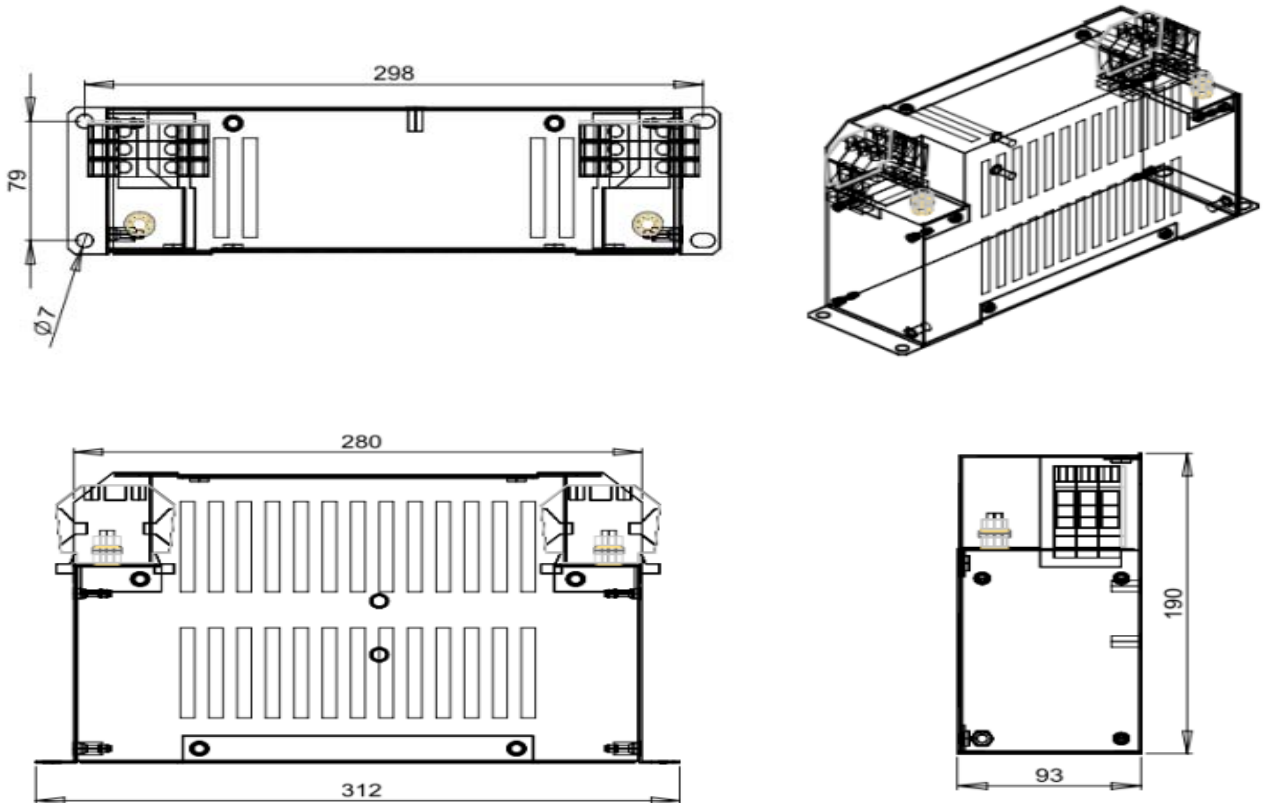

EMC filter model name: B84143D0150R127

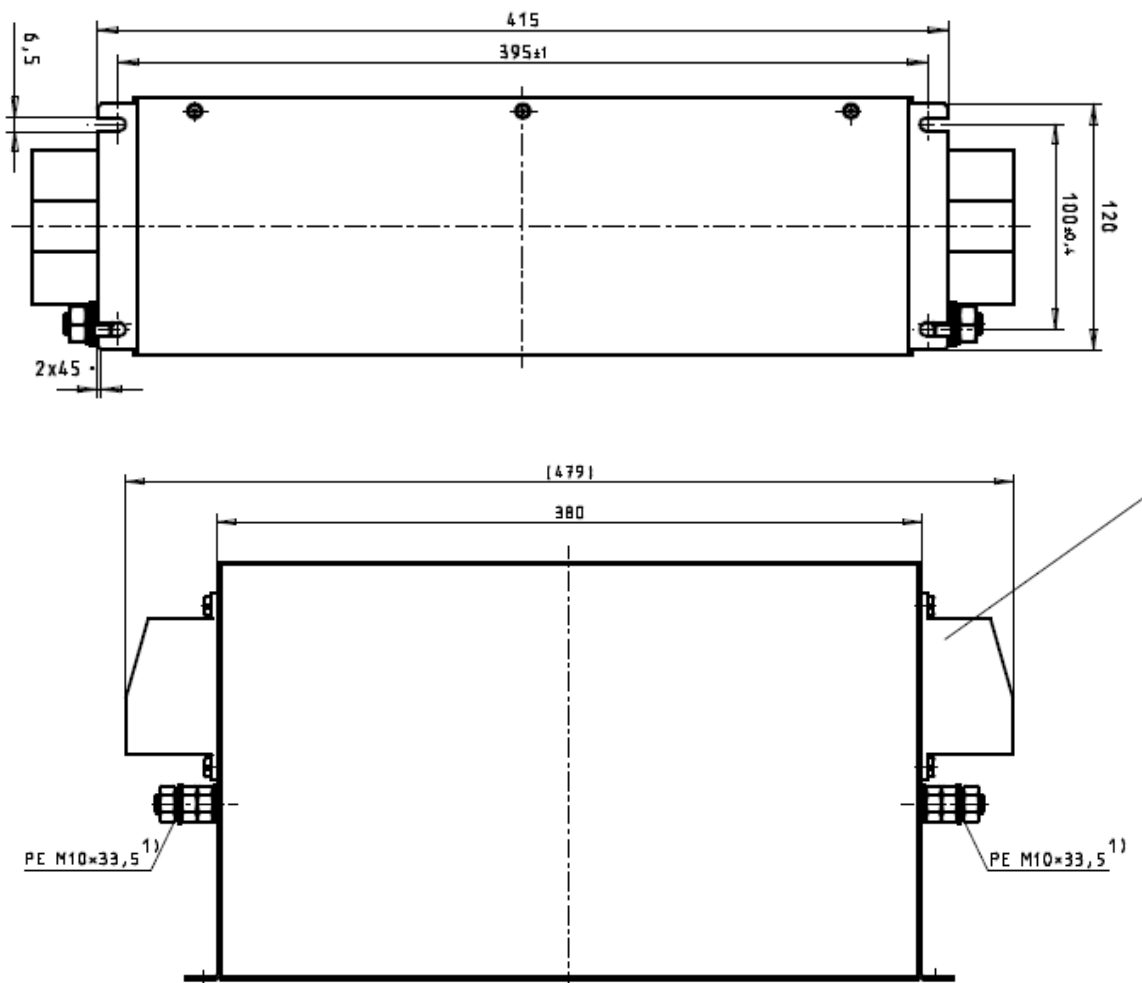



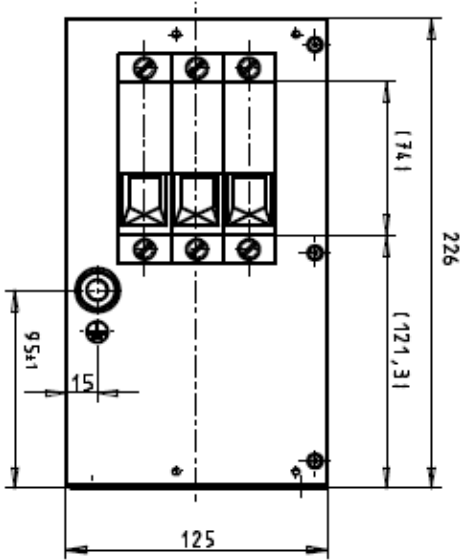

EMC filter model name: B84143D0200R127

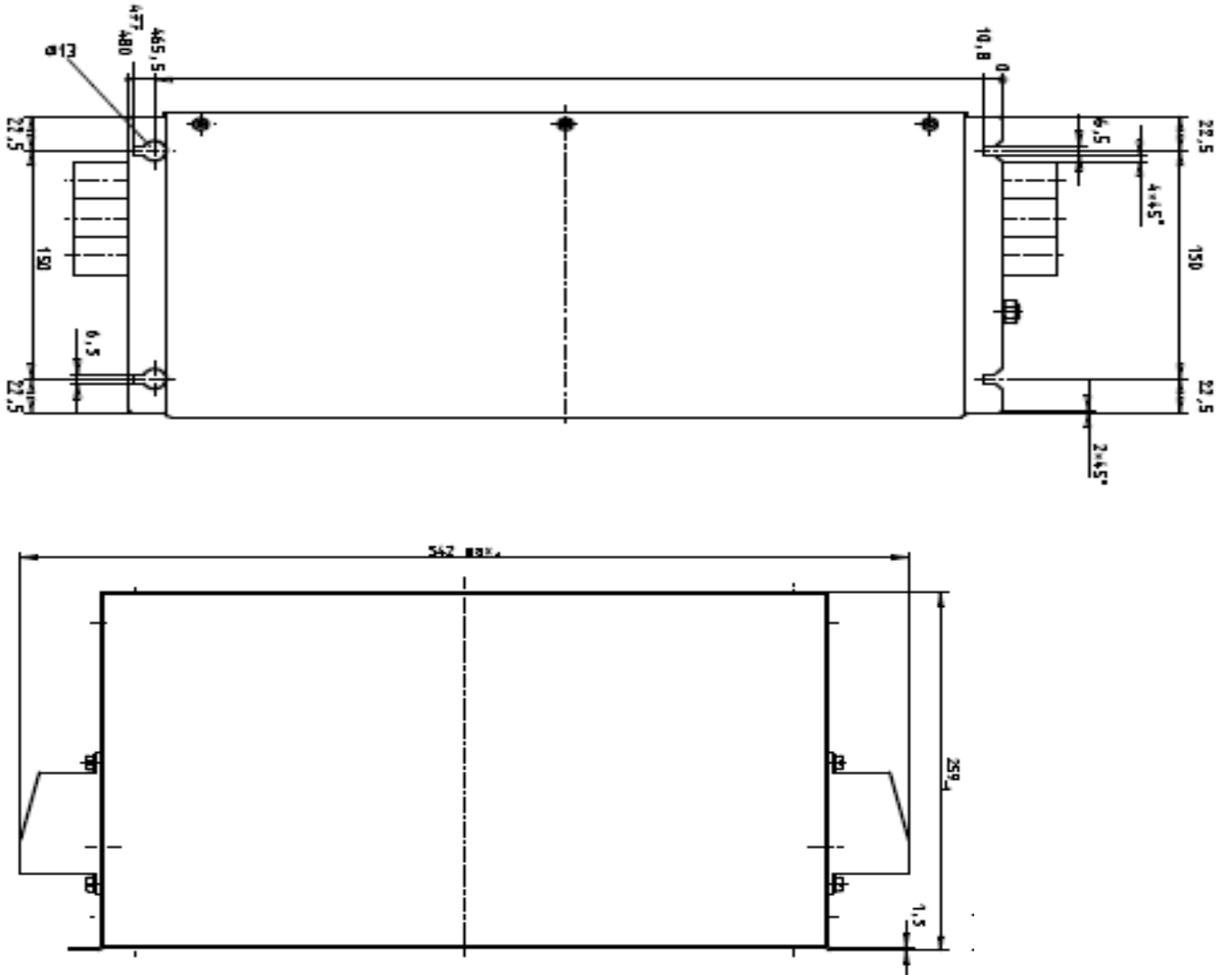

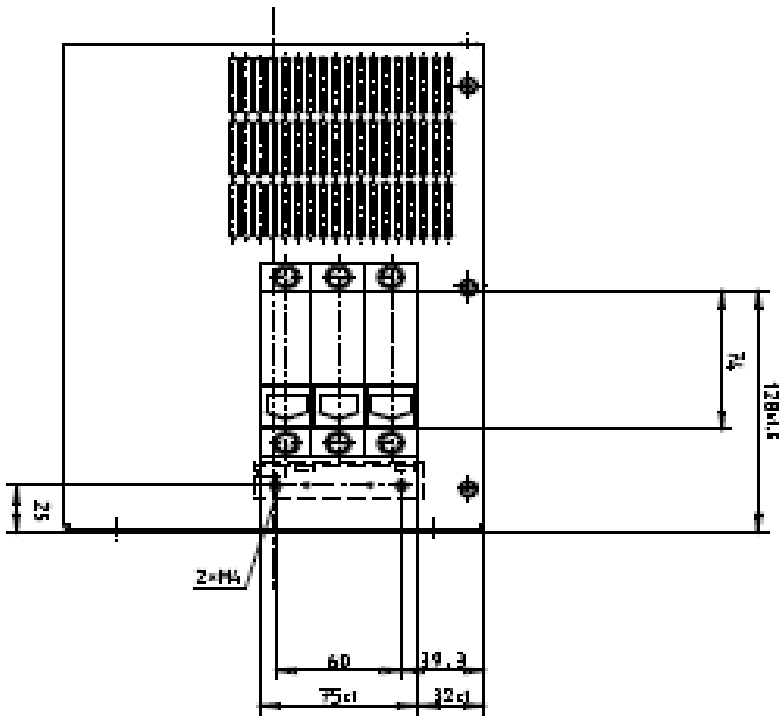

EMC filter model name: B84143B0250S020

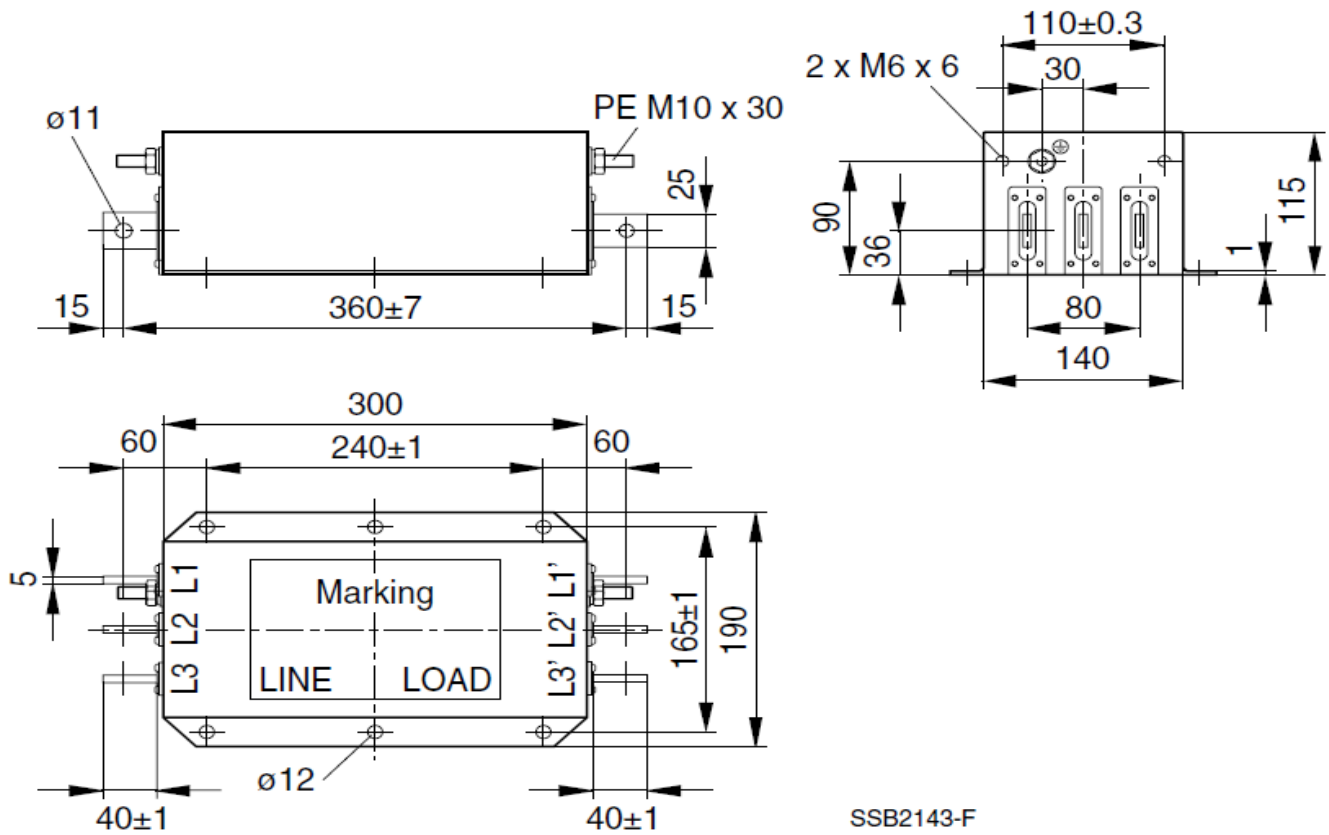

SSB2143-F

EMC filter model name: B84143B0400S020

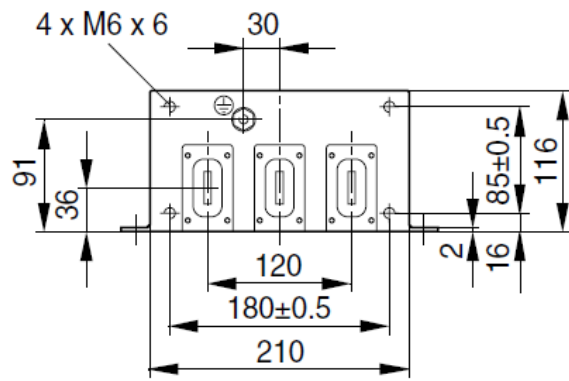
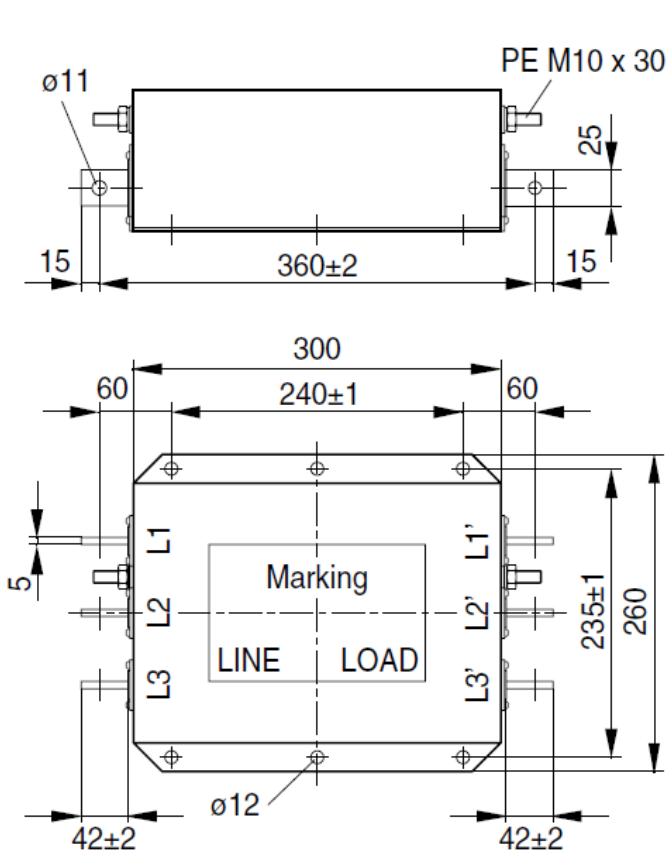

SSB2144-N

EMC filter model name: B84143B1000S020

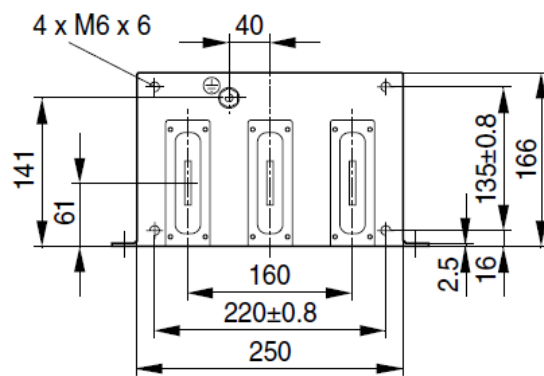
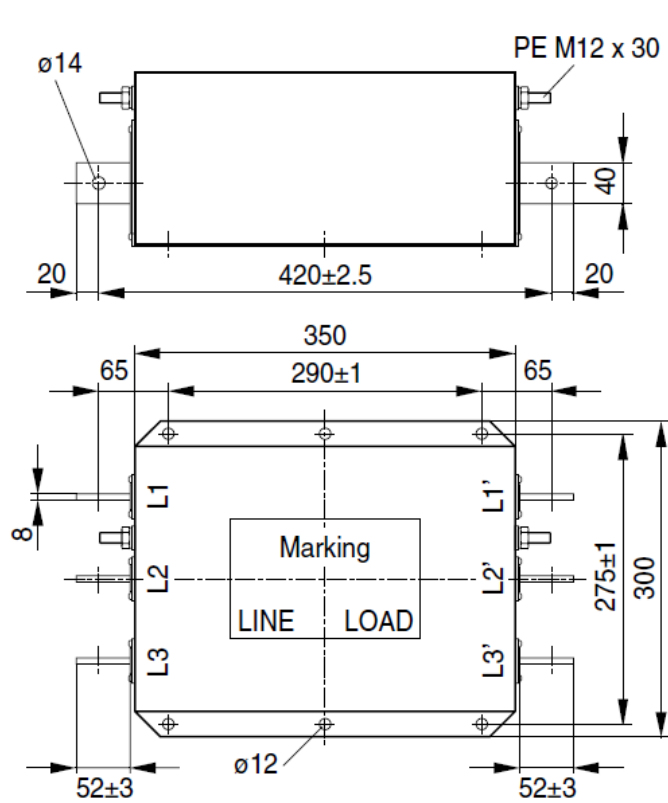

SSB2146-5

EMC filter model name: EMF014A63A

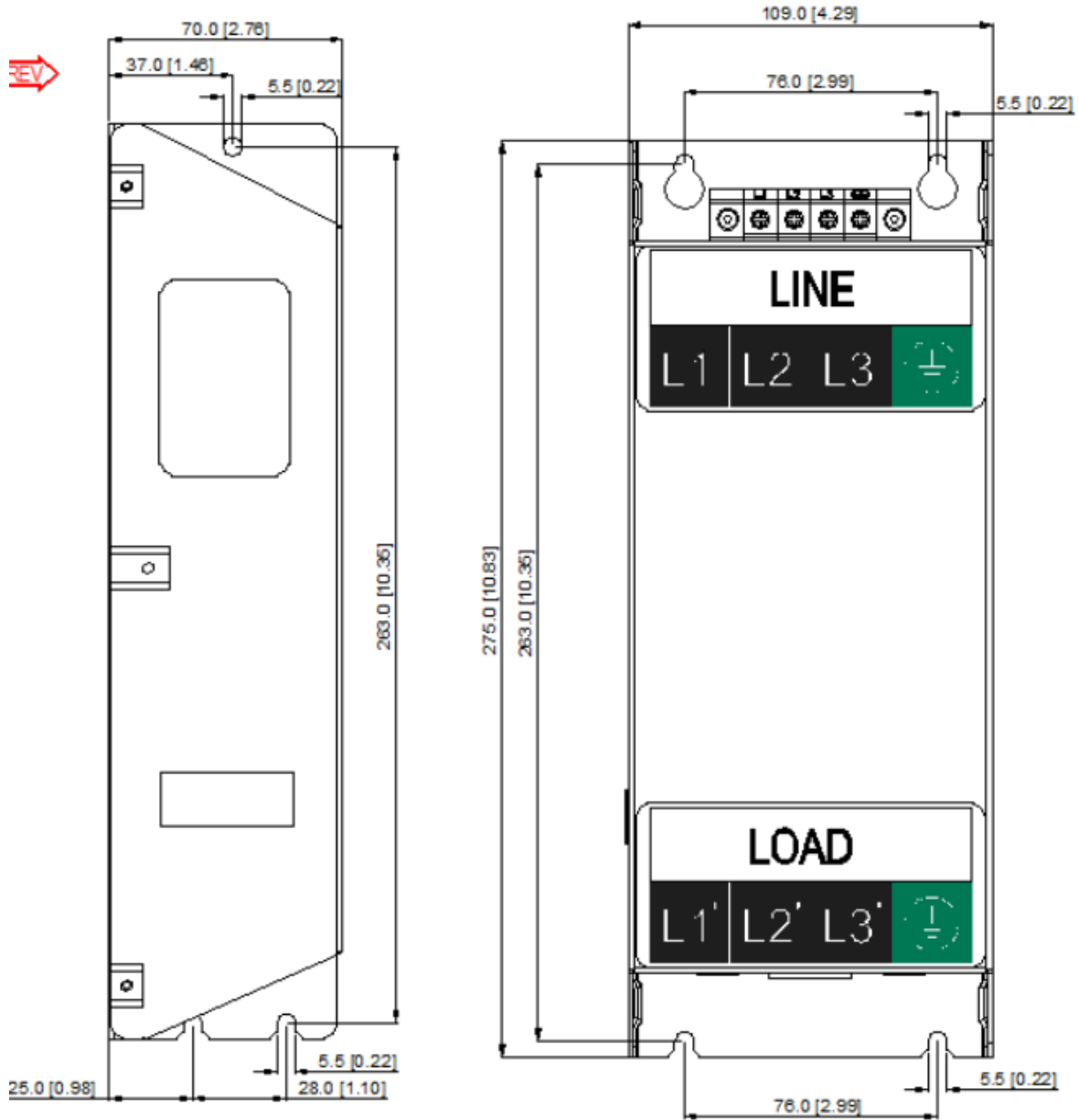

Unit: mm [inch]

EMC filter model name: EMF027A63A

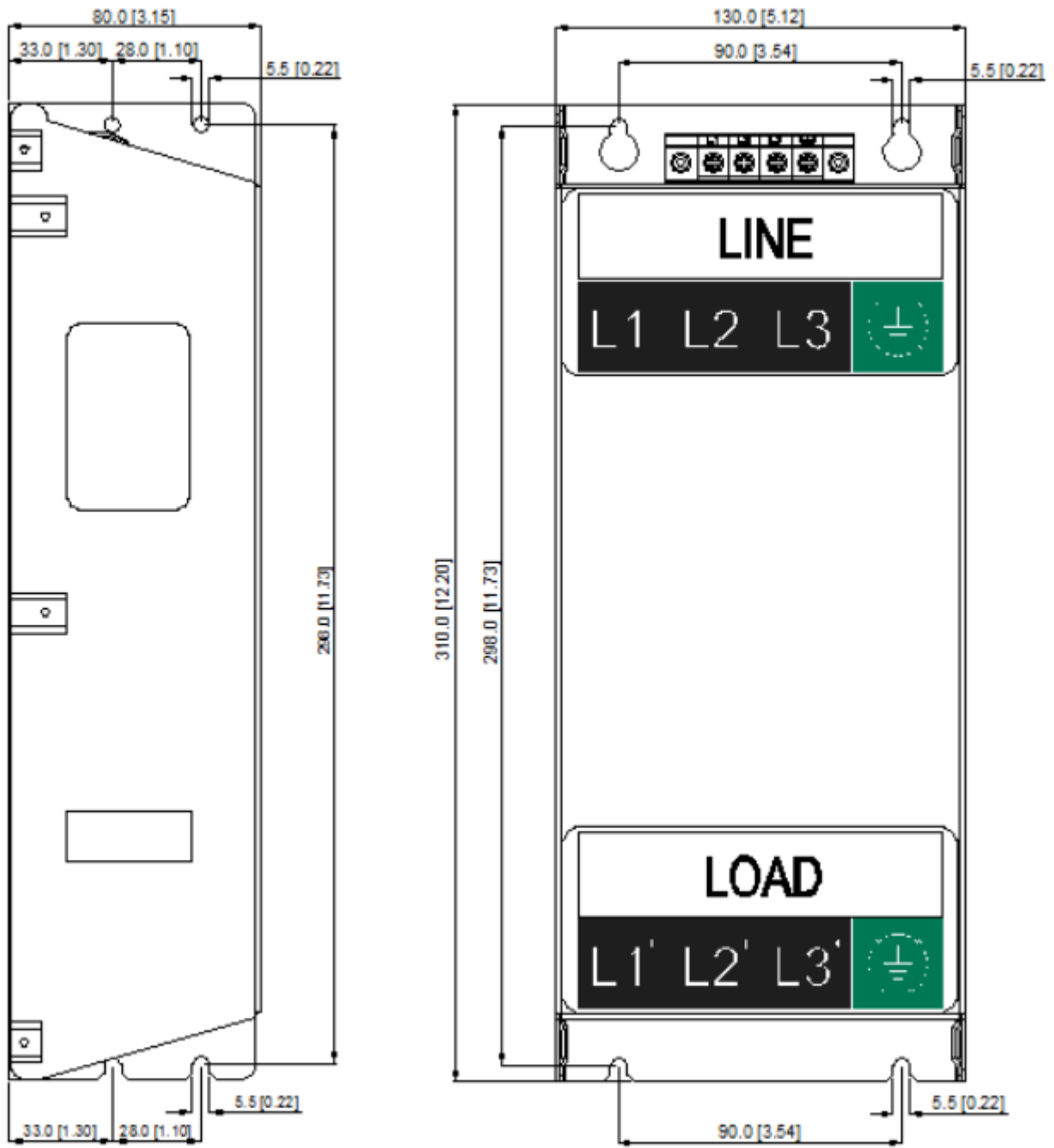

Unit: mm [inch]

EMC filter model name: B84143A0050R021

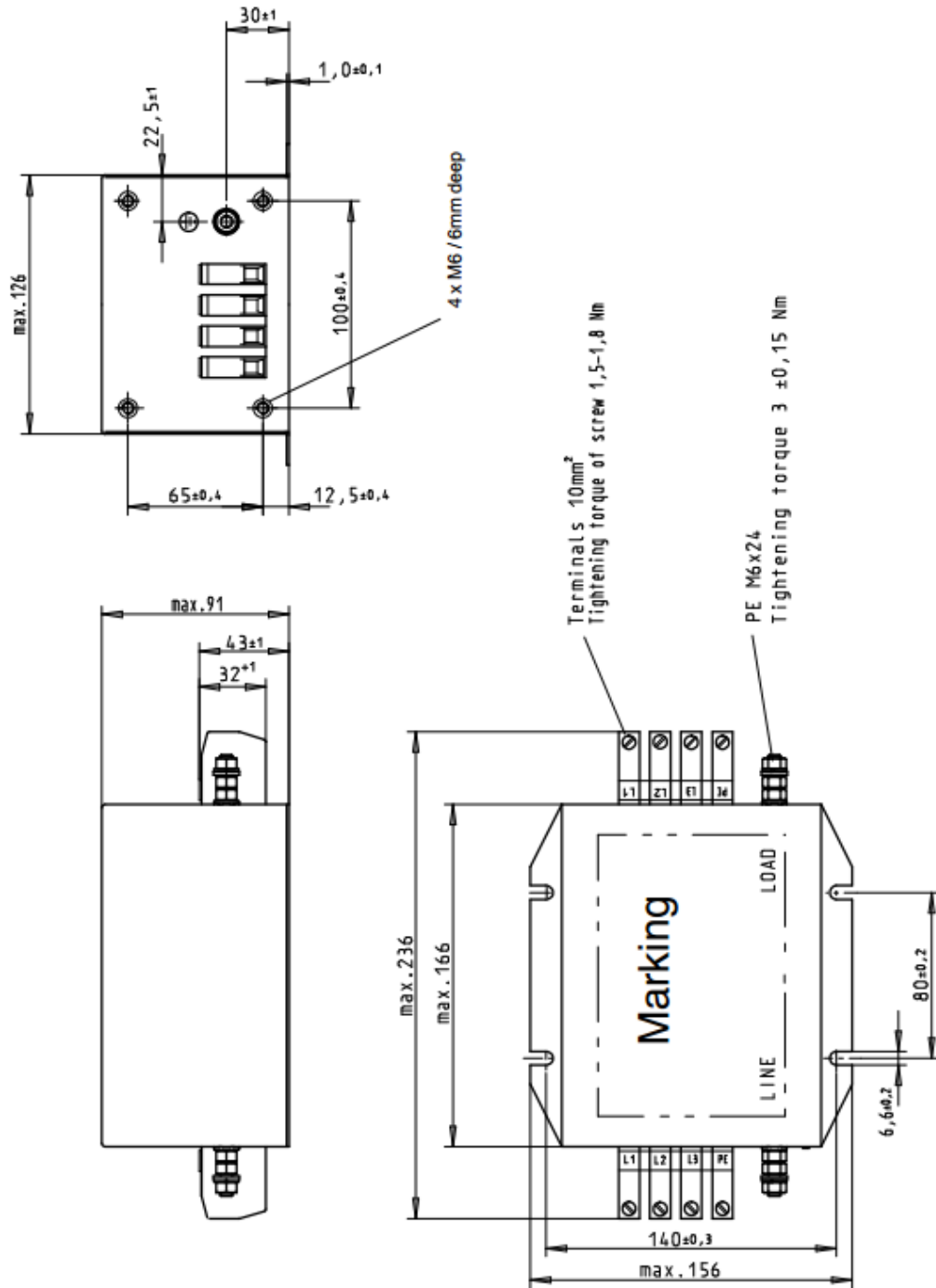

Unit: mm

EMC filter model name: B84143A0080R021

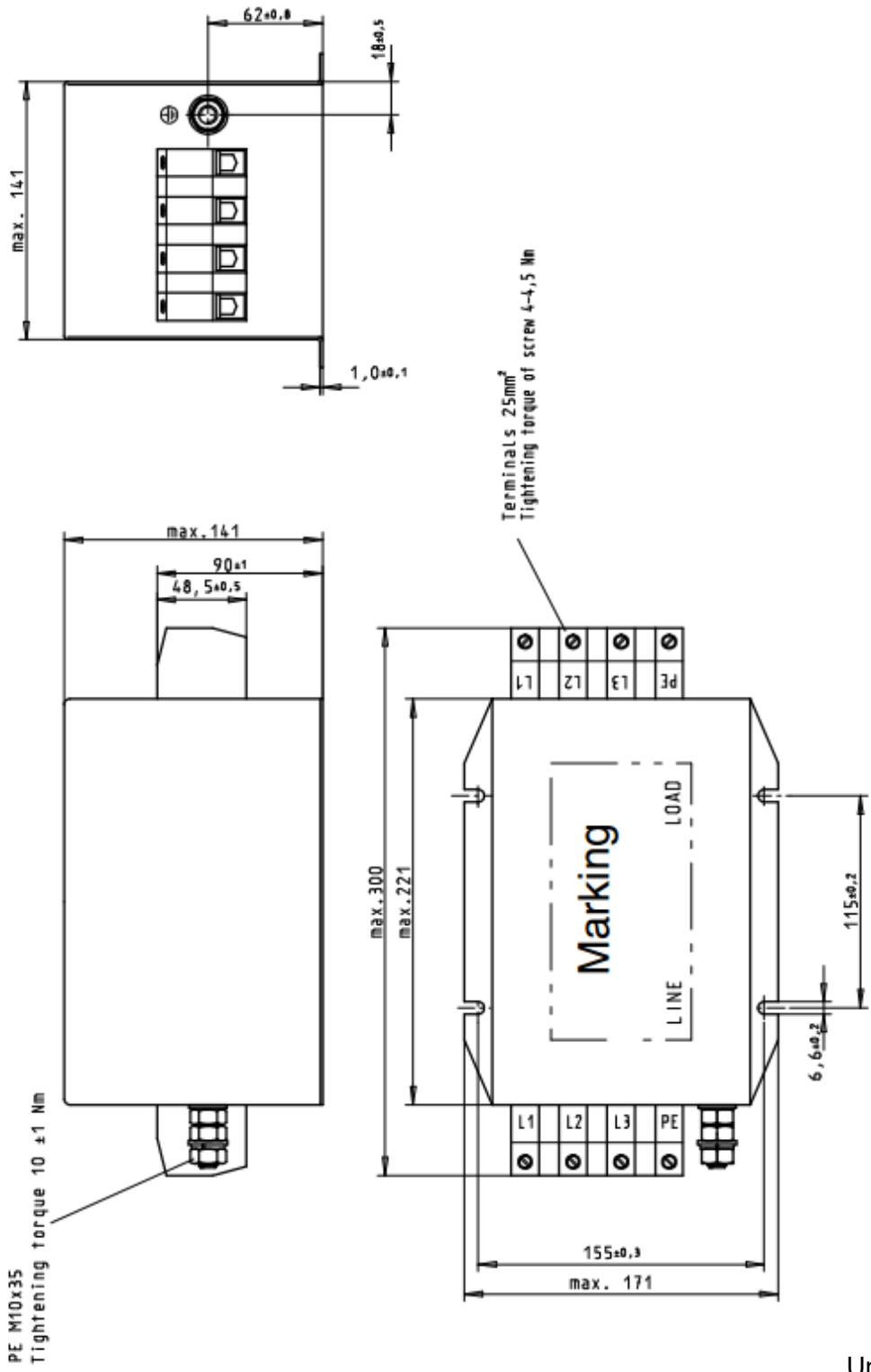

Unit: mm

EMC filter model name: B84143B0150S021

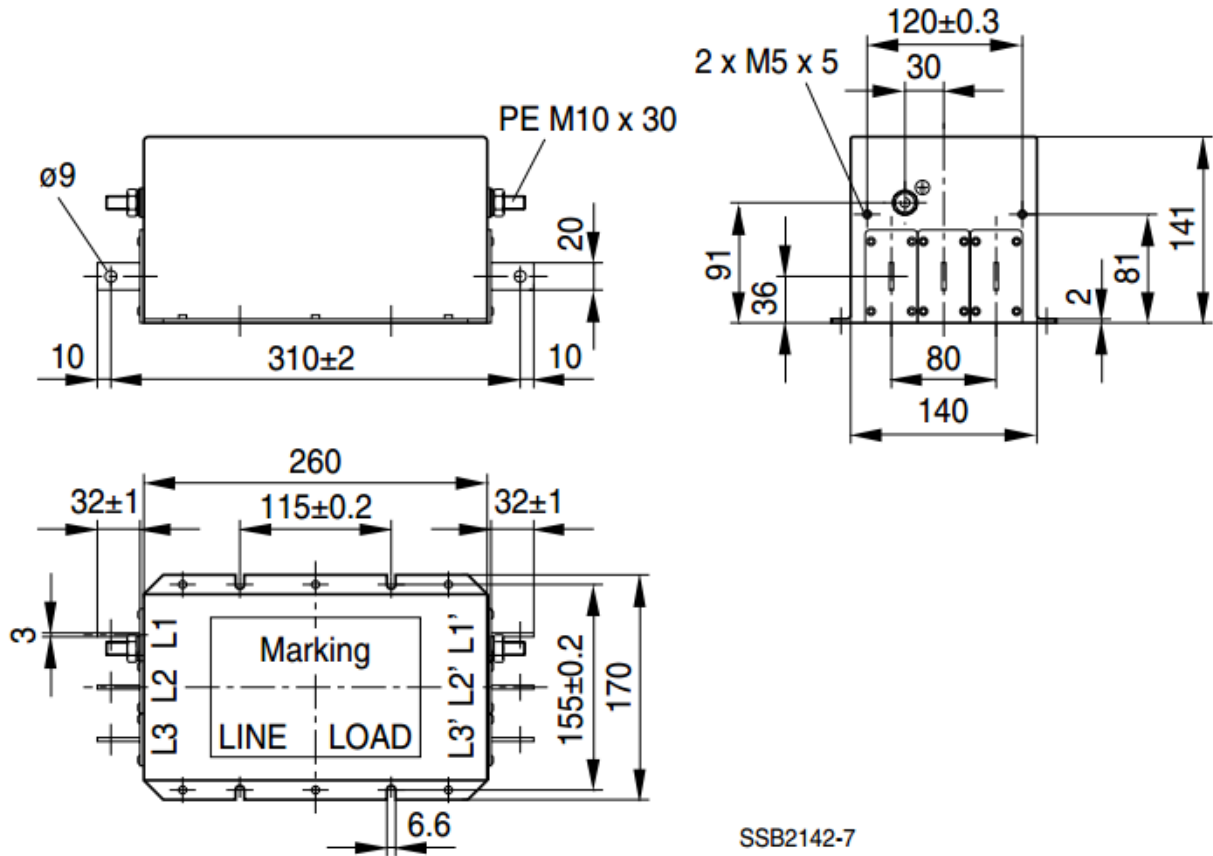

EMC filter model name: B84143B0250S021

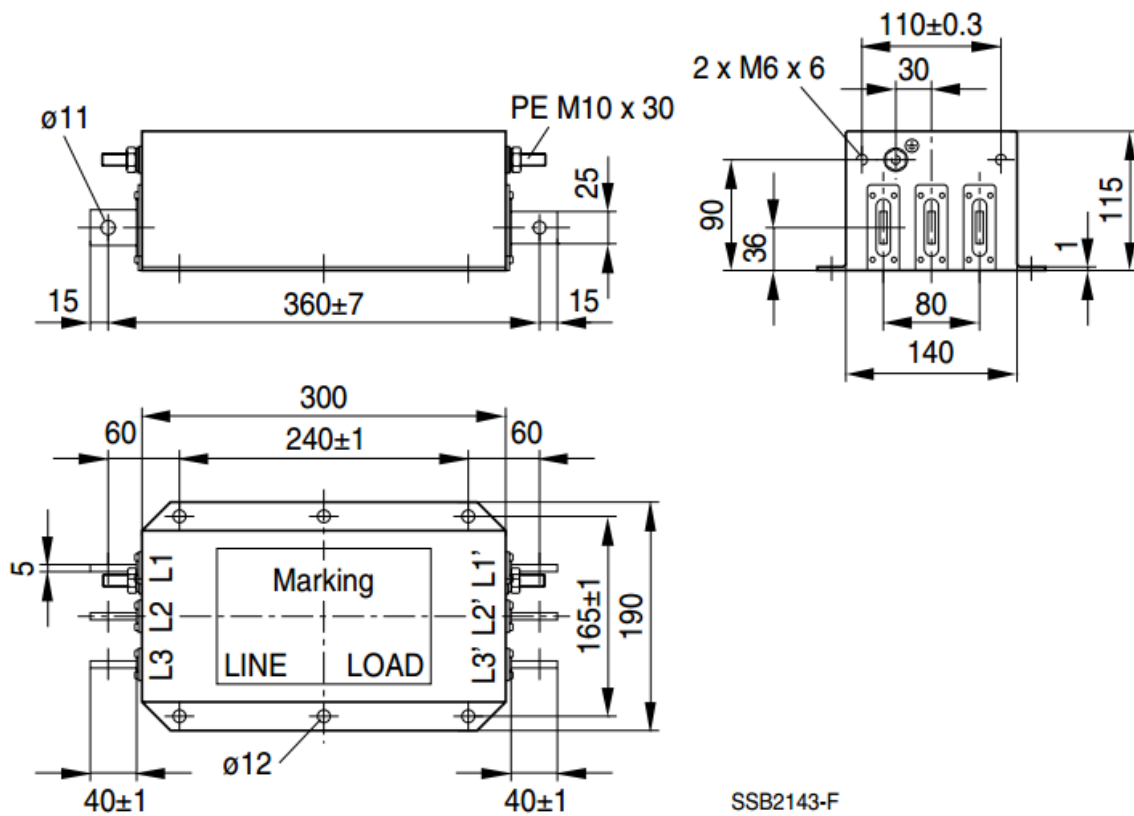



EMC filter model name: B84143B0400S021

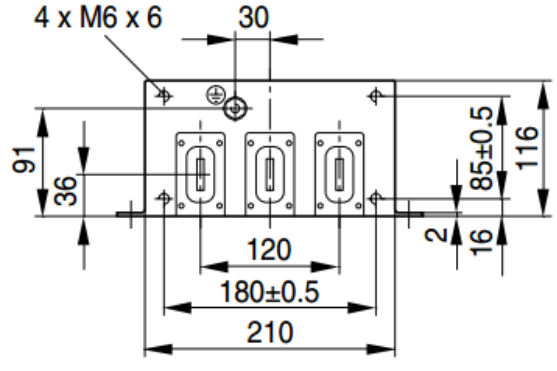
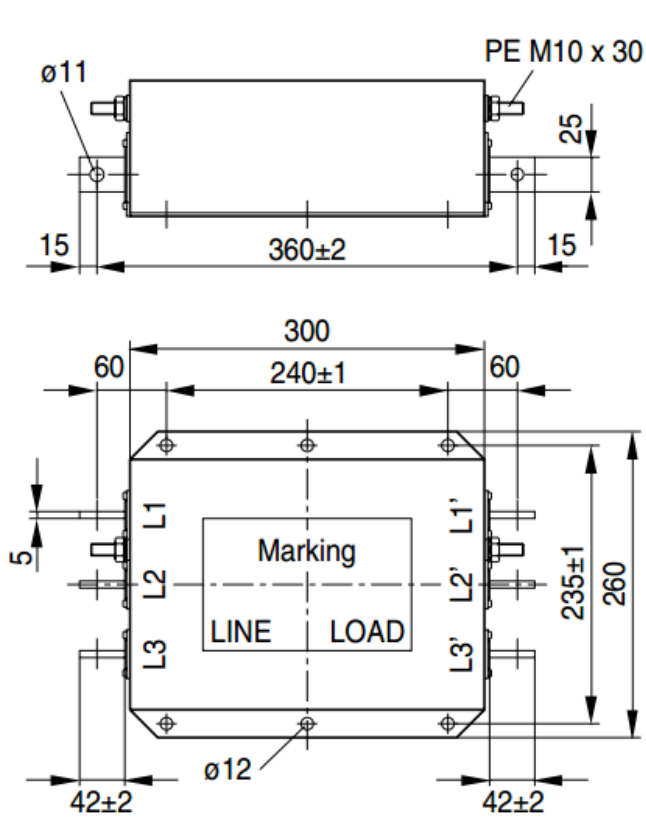

Unit: mm

SSB2144-N

EMC filter model name: B84143B1000S021

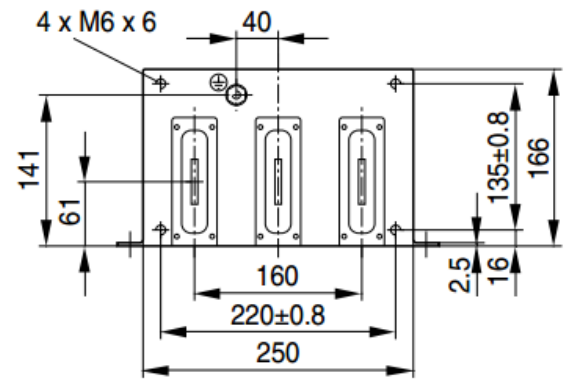
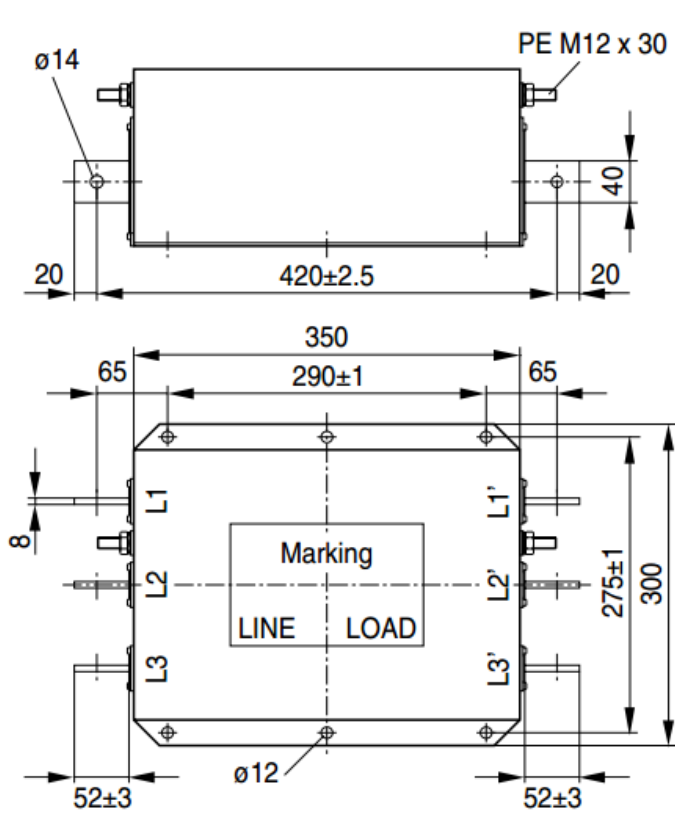

Unit: mm

SSB2146-5

Following table is the suggested shielded cable length of EMC built-in models. User can choose corresponding shielded cable length in accord to required noise emission and electromagnetic interference level.

EMC built-in model		Rated current (ND)	Comply with EMC (IEC 61800-3) Class C3		Comply with EMC (IEC 61800-3) Class C2	
Frame	Model		Shielded cable length	Fc	Shielded cable length	Fc
A	VFD007C43E	4.3	30m	≤ 8kHz	10m	≤ 8kHz
	VFD015C43E	5.9				
	VFD022C43E	8.7				
	VFD037C43E	14				
	VFD040C43E	15.5				
	VFD055C43E	17				
B	VFD075C43E	20		≤ 6kHz	≤ 6kHz	
	VFD110C43E	26				
	VFD150C43E	35				
C	VFD185C43E	40				
	VFD220C43E	47				
	VFD300C43E	63				

Table 7-64

\* Shielded cable length of Frame A should be no longer than 30m and Frame B, C no longer than 50m to prevent cable length from being too long, which may cause built-in EMC filter malfunction due to overheat resulting from leakage current and larger wires parasitic capacitance.

## EMC Filter Installation

All electrical equipment, including AC motor drives, will generate high frequency/ low frequency noise and will interfere with peripheral equipment by radiation or conduction when in operation. By using an EMC filter with correct installation, much interference can be eliminated. It is recommended to use DELTA EMC filter to have the best interference elimination performance.

We assure that it can comply with following rules when AC motor drive and EMC filter are installed and wired according to user manual:

1. EN61000-6-4
2. EN61800-3: 1996
3. EN55011 (1991) Class A Group 1

### General precaution

To ensure EMC filter can maximize the effect of suppressing the interference of AC motor drive, the installation and wiring of AC motor drive should follow the user manual. In addition, be sure to observe the following precautions:

1. EMC filter and AC motor drive should be installed on the same metal plate.
2. Please install AC motor drive on footprint EMC filter or install EMC filter as close as possible to the AC motor drive.
3. Please wire as short as possible.
4. Metal plate should be grounded.
5. The cover of EMC filter and AC motor drive or grounding should be fixed on the metal plate and the contact area should be as large as possible.

### Choose suitable motor cable and precautions

Improper installation and choice of motor cable will affect the performance of EMC filter. Be sure to observe the following precautions when selecting motor cable.

1. Use the cable with shielding (double shielding is the best).
2. The shielding on both ends of the motor cable should be grounded with the minimum length and maximum contact area.
3. Remove any paint on metal saddle for good ground contact with the plate and shielding.

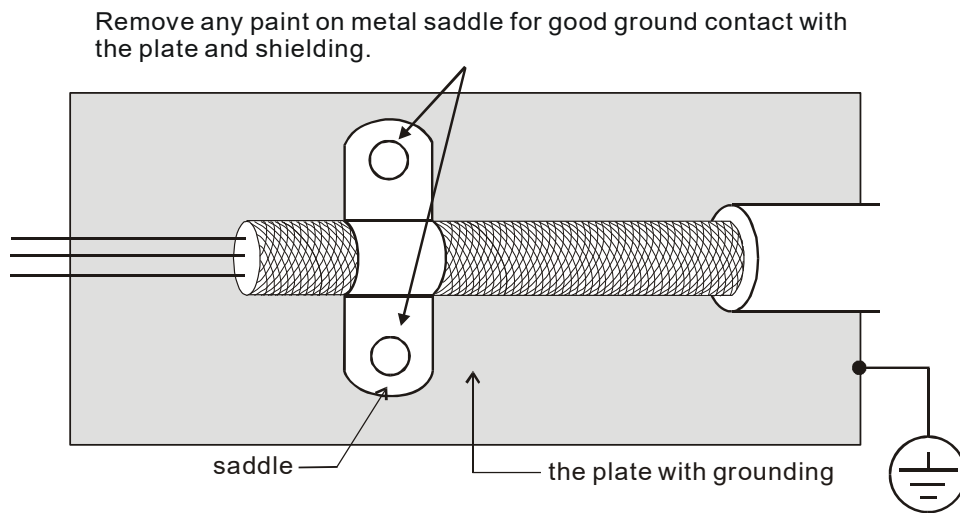

Figure 1

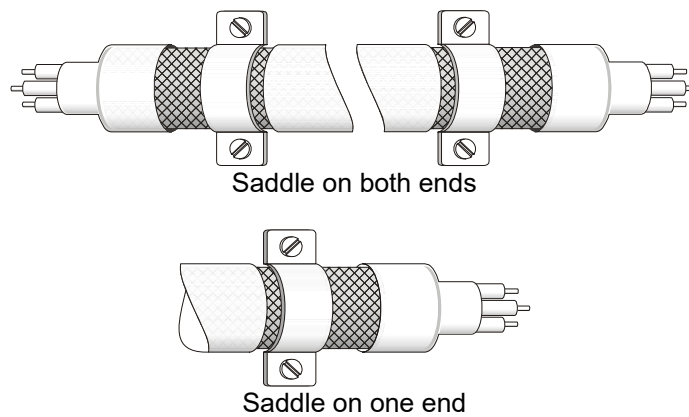

Figure 2

## Capacitor Filter

Capacitor Filter is a simple filter accessory, installed to provide simple filtering and eliminating interference.

### Installation

Installed on the input side, connect each cable on terminal R, S, T and PE. As shown in the figure below. (Please do NOT install the capacitor filter on the output side.)

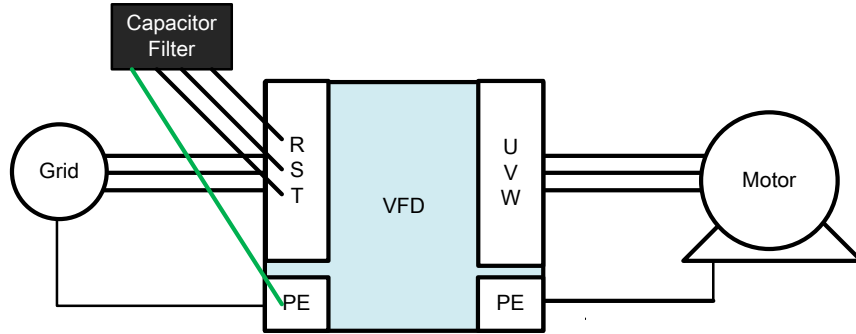

### Model / Specification

Model	Capacitance of the capacitor	Temperature
CXY101-43A	Cx : 1uF±20% Cy : 1uF±20%	-40~+85°C

Unit: mm [inch]

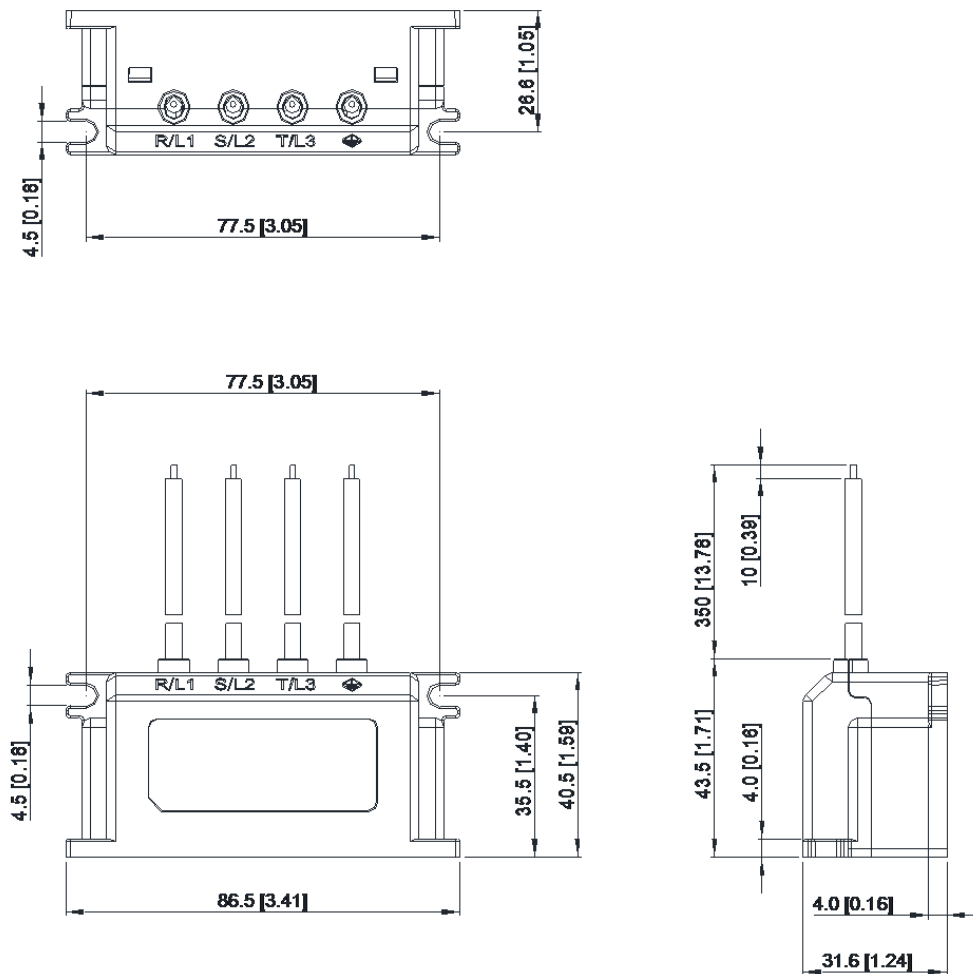

### 7-7 Panel Mounting (MKC-KPPK)

For MKC-KPPK model, user can choose wall mounting or embedded mounting, protection level is IP66.

Applicable to the digital keypads (KPC-CC01 & KPC-CE01)

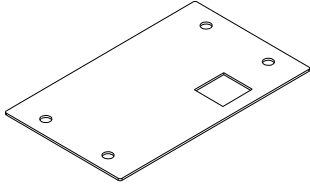
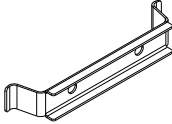
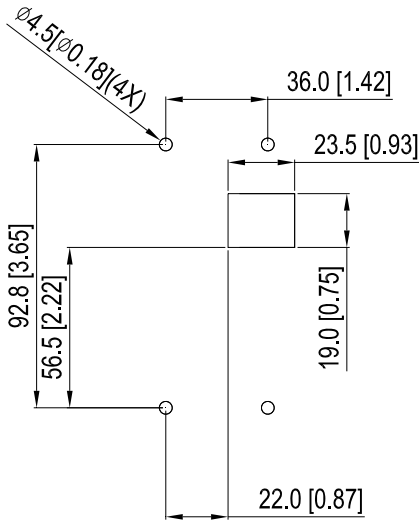
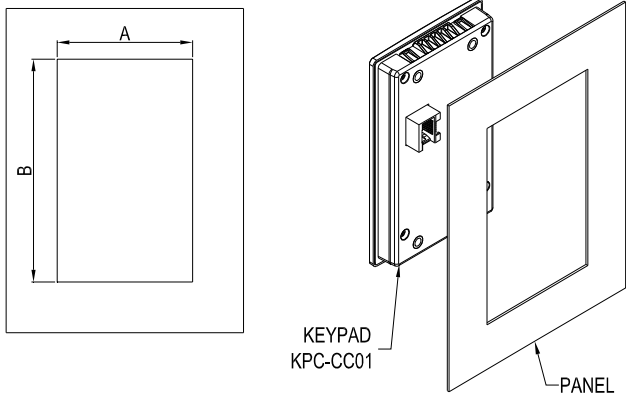
Wall Mounting		Embedded Mounting													
accessories*1  <p>Screw *4 ~M4*p 0.7 *L8mm Torque: 10~12 kg-cm / [8.7~10.4 lb-in.] / [1.0~1.2 Nm]</p>		accessories*2  <p>Screw *4 ~M4*p 0.7 *L8mm Torque: 10~12 kg-cm / [8.7~10.4 lb-in.] / [1.0~1.2 Nm]</p>													
Panel cutout dimension	Unit: mm [inch]	Panel cutout dimension	Unit: mm [inch]												
															
		<b>Normal cutout dimension</b> <table border="1"> <thead> <tr> <th>Panel thickness</th> <th>1.2mm</th> <th>1.6mm</th> <th>2.0mm</th> </tr> </thead> <tbody> <tr> <td>A</td> <td colspan="3">66.4 [2.614]</td> </tr> <tr> <td>B</td> <td>110.2 [4.339]</td> <td>111.3 [4.382]</td> <td>112.5 [4.429]</td> </tr> </tbody> </table> <p>*Deviation: ±0.15mm / ±0.0059inch Table 7-65</p>		Panel thickness	1.2mm	1.6mm	2.0mm	A	66.4 [2.614]			B	110.2 [4.339]	111.3 [4.382]	112.5 [4.429]
Panel thickness	1.2mm	1.6mm	2.0mm												
A	66.4 [2.614]														
B	110.2 [4.339]	111.3 [4.382]	112.5 [4.429]												
		<b>Cutout dimension (Waterproof level: IP66)</b> <table border="1"> <thead> <tr> <th>Panel thickness</th> <th>1.2mm</th> <th>1.6mm</th> <th>2.0mm</th> </tr> </thead> <tbody> <tr> <td>A</td> <td colspan="3">66.4 [2.614]</td> </tr> <tr> <td>B</td> <td colspan="3">110.8 [4.362]</td> </tr> </tbody> </table> <p>*Deviation: ±0.15mm / ±0.0059inch Table 7-66</p>		Panel thickness	1.2mm	1.6mm	2.0mm	A	66.4 [2.614]			B	110.8 [4.362]		
Panel thickness	1.2mm	1.6mm	2.0mm												
A	66.4 [2.614]														
B	110.8 [4.362]														

Wall Mounting

Embedded Mounting

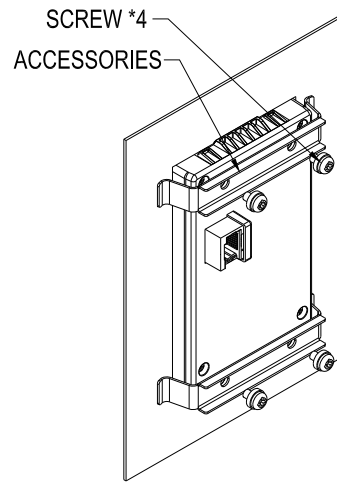
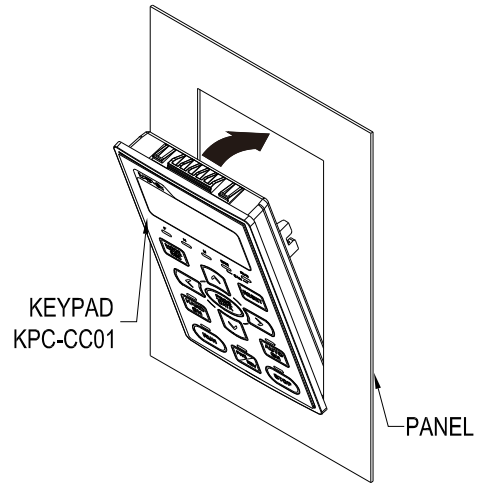
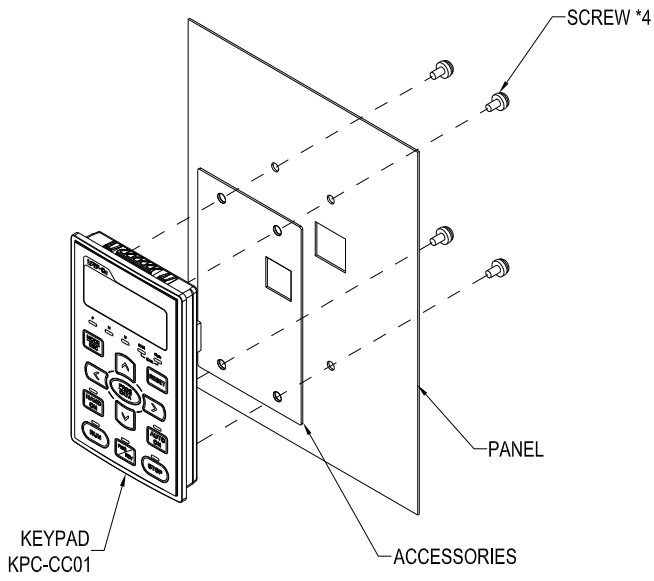

## 7-8 Conduit Box Kit

### ■ Appearance

Conduit box kit is optional for VFDXXXCXXA (Frame D and above) and VFDXXXC43S, the protection will be IP20/ NEMA1/ UL TYPE1 after installation.

#### Frame D0

Applicable models

VFD370C43S/43U; VFD450SC43S/43U

Model number 『MKC-D0N1CB』

ITEM	Description	Qty.
1	Screw M5*0.8*10L	4
2	Bushing Rubber 28	2
3	Bushing Rubber 44	2
4	Bushing Rubber 73	2
5	Conduit box cover	1
6	Conduit box base	1

Table 7-67

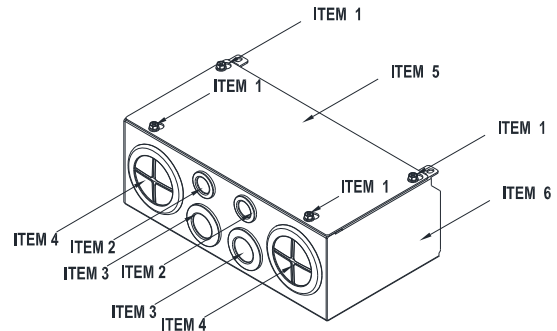

#### Frame D

Applicable models

VFD300C23A/23E; VFD370C23A/23E; VFD550C43A/43E; VFD750C43A/43E; VFD450C63B-00; VFD550C63B-00; VFD450C63B-21; VFD550C63B-21

Model number 『MKC-DN1CB』

ITEM	Description	Qty.
1	Screw M5*0.8*10L	4
2	Bushing Rubber 28	2
3	Bushing Rubber 44	2
4	Bushing Rubber 88	2
5	Conduit box cover	1
6	Conduit box base	1

Table 7-68

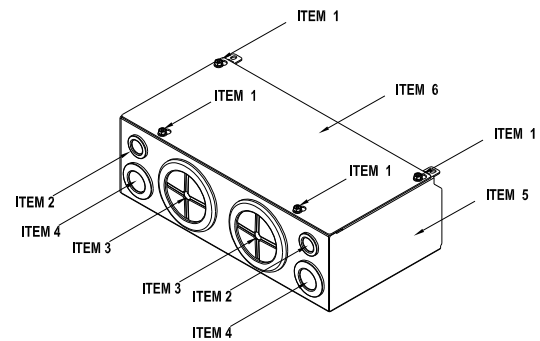

#### Frame E

Applicable models

VFD450C23A/23E; VFD550C23A/23E; VFD750C23A/23E; VFD900C43A/43E; VFD1100C43A/43E; VFD750C63B-00; VFD900C63B-00; VFD1100C63B-00; VFD1320C63B-00; VFD750C63B-21; VFD900C63B-21; VFD1100C63B-21; VFD1320C63B-21

Model number 『MKC-EN1CB』

ITEM	Description	Qty.
1	Screw M5*0.8*10L	6
2	Bushing Rubber 28	2
3	Bushing Rubber 44	4
4	Bushing Rubber 100	2
5	Conduit box cover	1
6	Conduit box base	1

Table 7-69

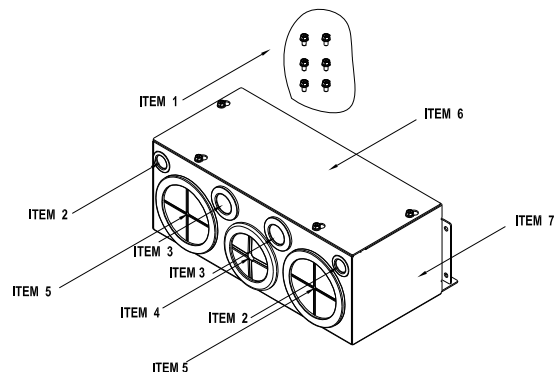

**Frame F**

Applicable models

VFD900C23A/23E; VFD1320C43A/43E; VFD1600C43A/43E; VFD1600C63B-00; VFD2000C63B-00;  
VFD1600C63B-21; VFD2000C63B-21

Model number 『MKC-FN1CB』

ITEM	Description	Qty.
1	Screw M5*0.8*10L	8
2	Bushing Rubber28	2
3	Bushing Rubber 44	4
4	Bushing Rubber 100	2
5	Conduit box cover	1
6	Conduit box base	1

Table 7-70

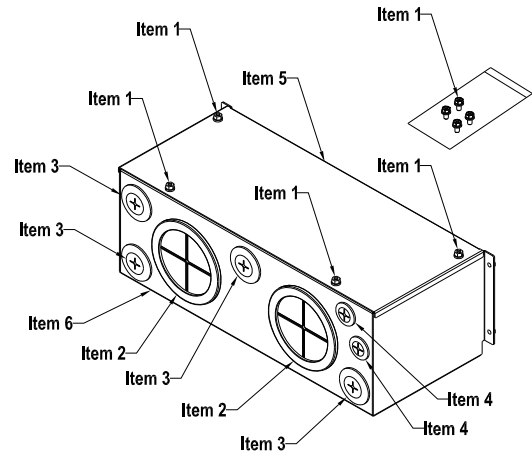

**Frame G**

Applicable models

VFD1850C43A/43E; VFD2200C43A/43E; VFD2500C63B-00; VFD3150C63B-00; VFD2500C63B-21;  
VFD3150C63B-21

Model number 『MKC-GN1CB』

ITEM	Description	Qty.
1	Screw M5*0.8*10L	12
2	Bushing Rubber 28	2
3	Bushing Rubber 44	2
4	Bushing Rubber 130	3
5	Conduit box cover	1
6	Conduit box base	1

Table 7-71

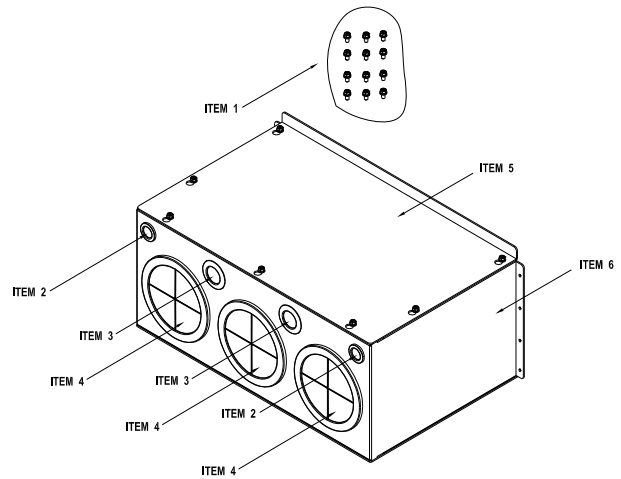



Frame H

Applicable models

VFD2800C43A; VFD3150C43A; VFD3550C43A; VFD4500C43A; VFD2800C43E; VFD3150C43E;  
 VFD3550C43E; VFD4500C43E; VFD2800C43E-1; VFD3150C43E-1; VFD3550C43E-1; VFD4500C43E-1

Model number 『MKC-HN1CB』

ITEM	Description	Qty.
1	Screw M6*1.0*25L	8
2	Screw M8*1.25*30L	3
3	NUT M8	4
4	NUT M10	4
5	Bushing Rubber 28	4
6	Bushing Rubber 44	2
7	Bushing Rubber 130	4
8	Conduit box cover 1	1
9	Conduit box cover 2	2
10	Conduit box cover 3	2
11	Conduit box cover 4	2
12	Conduit box base	1
13	Accessories 1	2
14	Accessories 2	1

Table 7-72

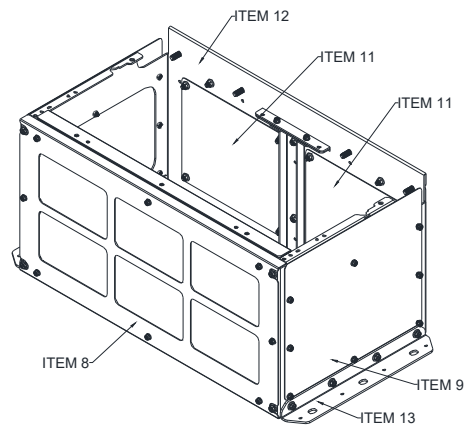
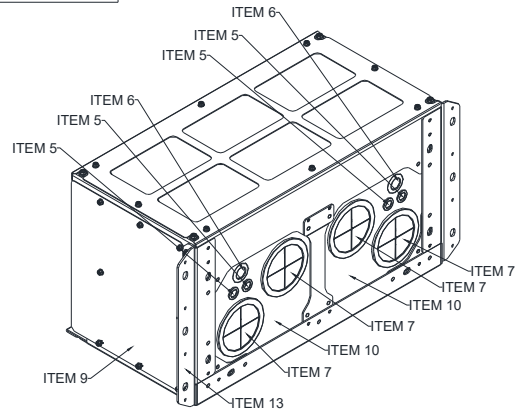
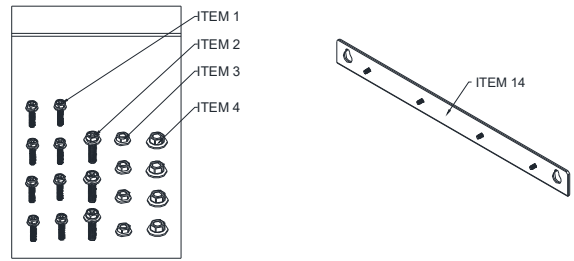

## ■ Conduit Box Installation

### Frame D0

1. Loosen the cover screws and press the tabs on each side of the cover to remove the cover, as shown in the following figure.  
Screw torque: 12~15 kg-cm / [10.4~13 lb-in.] / [1.2~1.5 Nm]

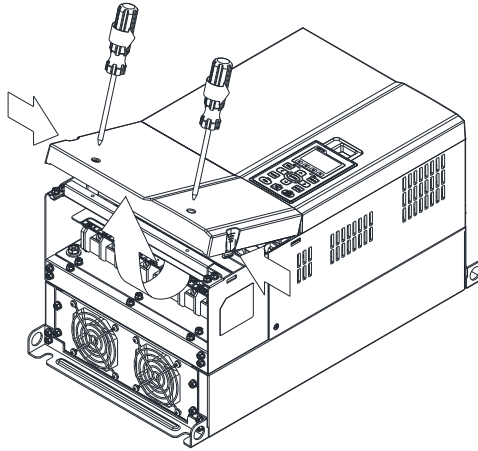

2. Remove the 5 screws shown in the following figure.  
Screw torque: 24~26 kg-cm / [20.8~22.6 lb-in.] / [2.4~2.5 Nm]

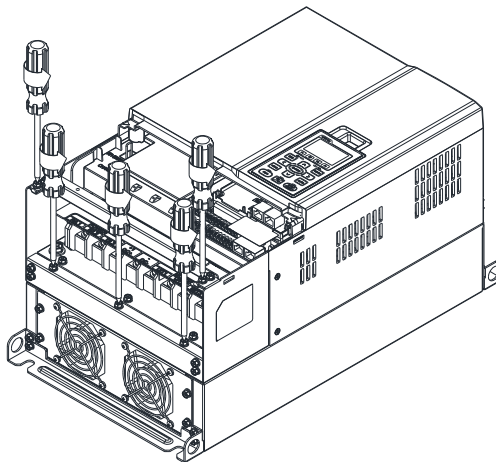

3. Install the conduit box by fasten the 5 screws shown in the following figure.  
Screw torque: 24~26 kg-cm / [20.8~22.6 lb-in.] / [2.4~2.5 Nm]

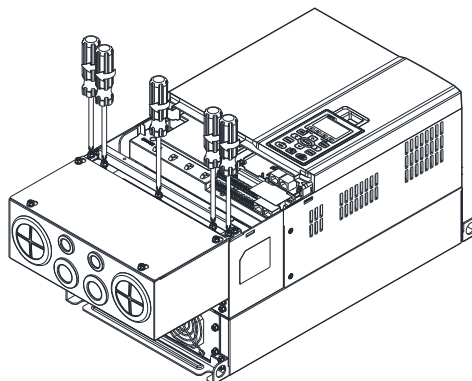

4. Fasten the 2 screws shown in the following figure.  
Screw torque: 12~15 kg-cm / [10.4~13 lb-in.] / [1.2~1.5 Nm]

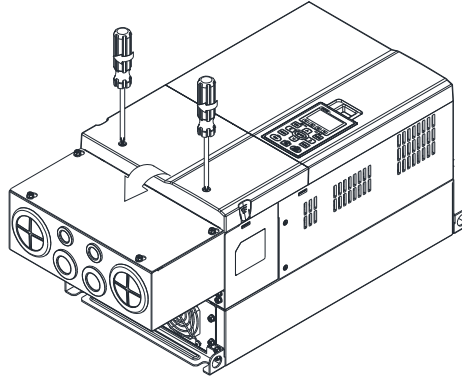

**Frame D**

1. Loosen the cover screws and press the tabs on each side of the cover to remove the cover, as shown in the following figure.  
Screw torque: 12~15 kg-cm / [10.4~13 lb-in.] / [1.2~1.5 Nm]

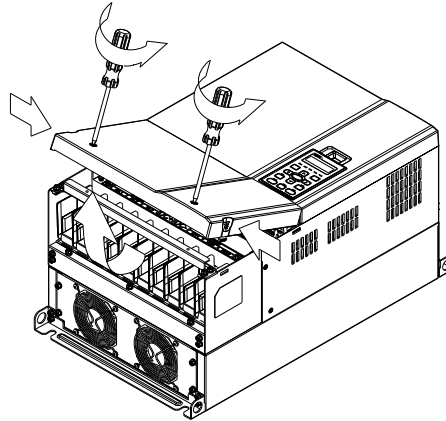

2. Remove the 5 screws shown in the following figure.  
Screw torque: 24~26 kg-cm / [20.8~22.6 lb-in.] / [2.4~2.5 Nm]

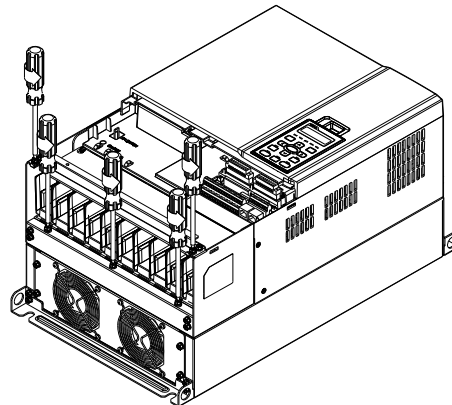

3. Install the conduit box by fasten the 5 screws shown in the following figure.  
Screw torque: 24~26 kg-cm / [20.8~22.6 lb-in.] / [2.4~2.5 Nm]

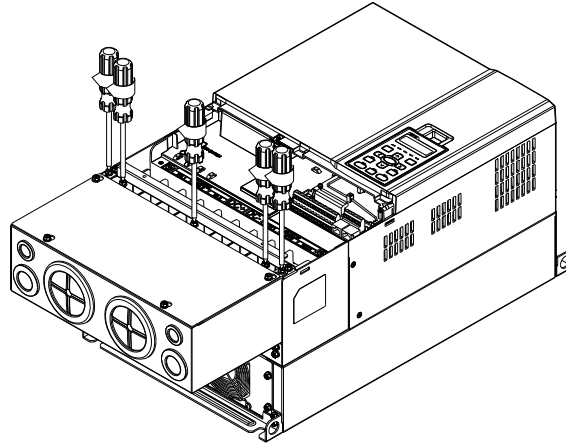

4. Fasten the 2 screws shown in the following figure. Screw torque: 12~15 kg-cm / [10.4~13 lb-in.] / [1.2~1.5 Nm]

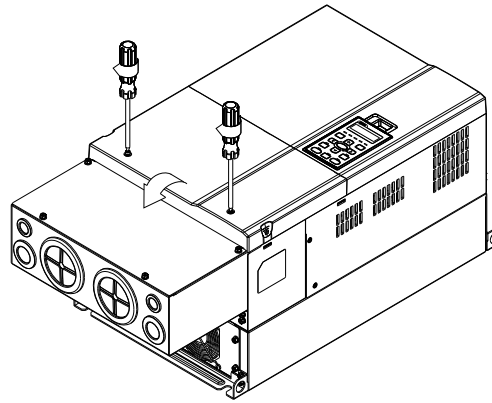

### Frame E

1. Loosen the 4 cover screws and lift the cover;  
Screw torque: 12~15 kg-cm / [10.4~13 lb-in.] / [1.2~1.5 Nm]

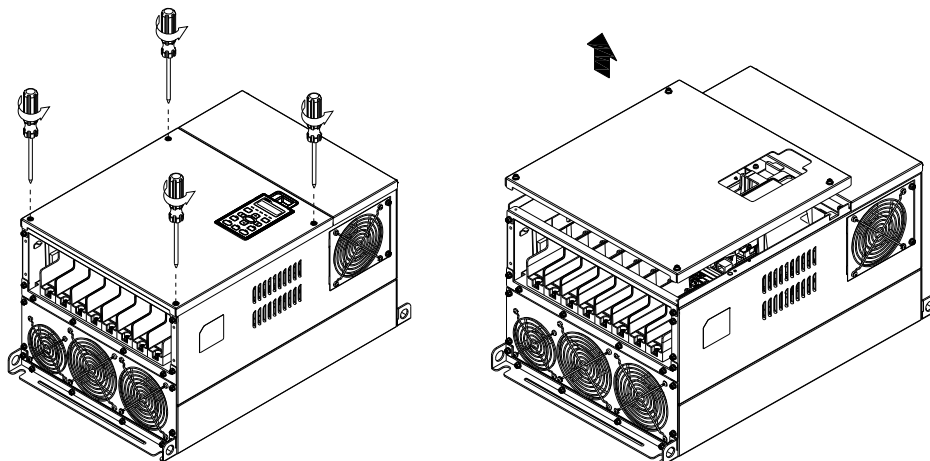

2. Fasten the 6 screws shown in the following figure and place the cover back to the original position.  
Screw torque: 24~26 kg-cm / [20.8~22.6 lb-in.] / [2.4~2.5 Nm]

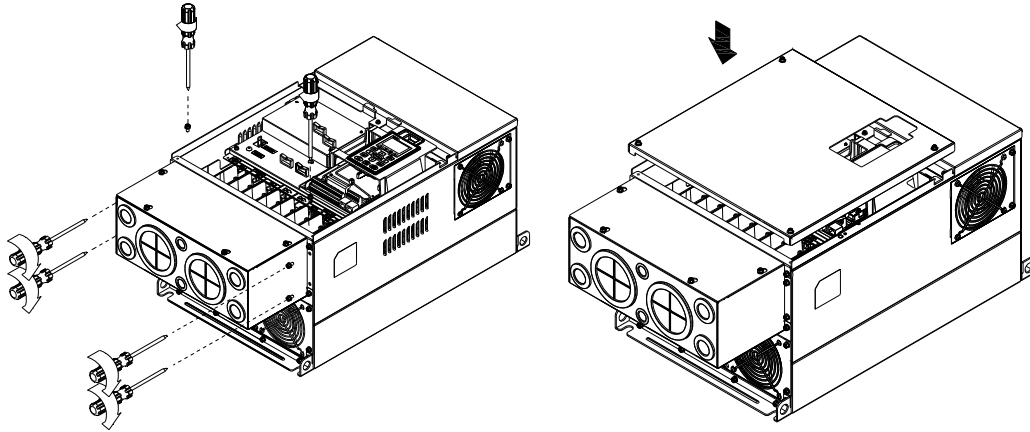

3. Fasten the 4 screws shown in the following figure.  
Screw torque: 12~15 kg-cm / [10.4~13 lb-in.] / [1.2~1.5 Nm]

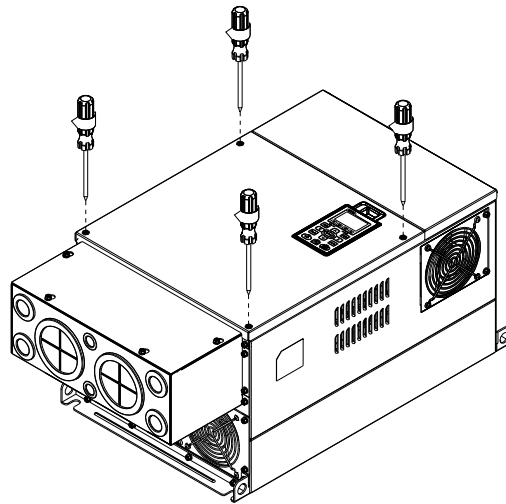

**Frame F**

1. Loosen the cover screws and press the tabs on each side of the cover to remove the cover, as shown in the following figure.  
Screw torque: 12~15 kg-cm / [10.4~13 lb-in.] / [1.2~1.5 Nm]

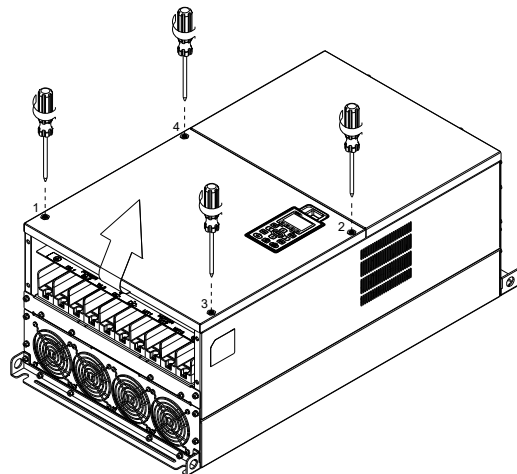

2. Install the conduit box by fastens the 4 screws, as shown in the following figure.  
Screw torque: 24~26 kg-cm / [20.8~22.6 lb-in.] / [2.4~2.5 Nm]

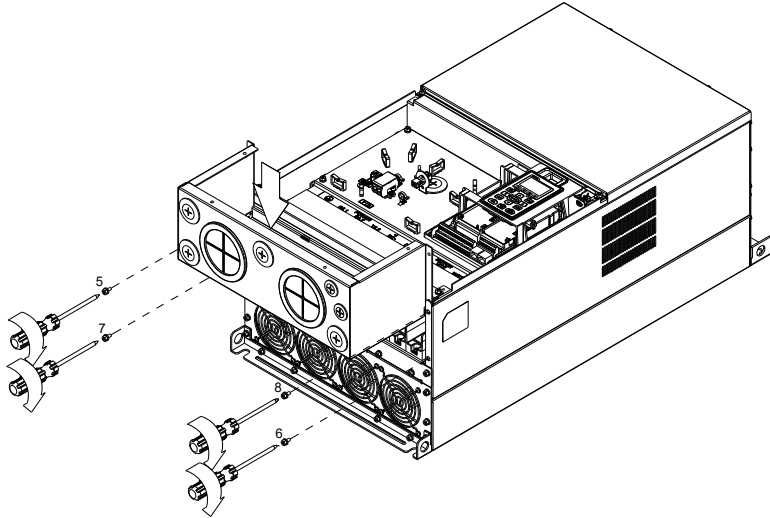

3. Install the conduit box by fasten all the screws shown in the following figure  
Screw 9~12 torque: 12~15 kg-cm / [10.4~13 lb-in.] / [1.2~1.5 Nm]  
Screw 13~16 torque: 24~26 kg-cm / [20.8~22.6 lb-in.] / [2.4~2.5 Nm]

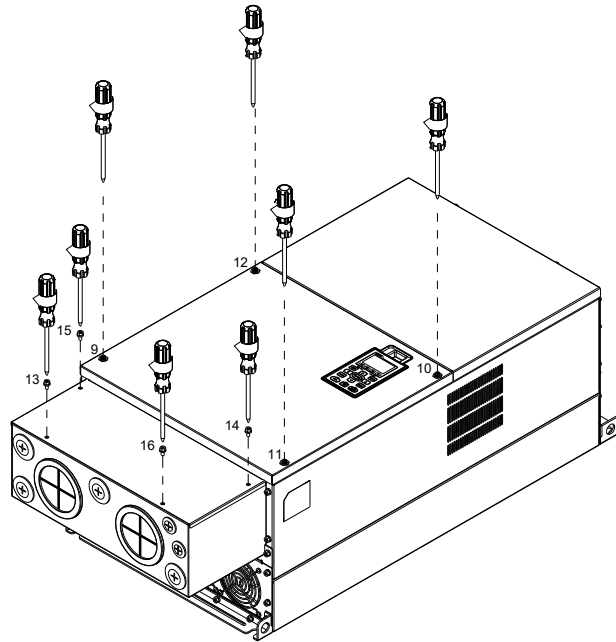

**Frame G**

1. On the conduit box, loosen 7 of the cover screws and remove the cover  
Screw torque: 24~26 kg-cm / [20.8~22.6 lb-in.] / [2.4~2.5 Nm]
2. On the drive, loosen 4 of the cover screws and press the tabs on each side of the cover to remove the cover, as shown in the following figure.  
Screw torque: 12~15 kg-cm / [10.4~13 lb-in.] / [1.2~1.5 Nm]

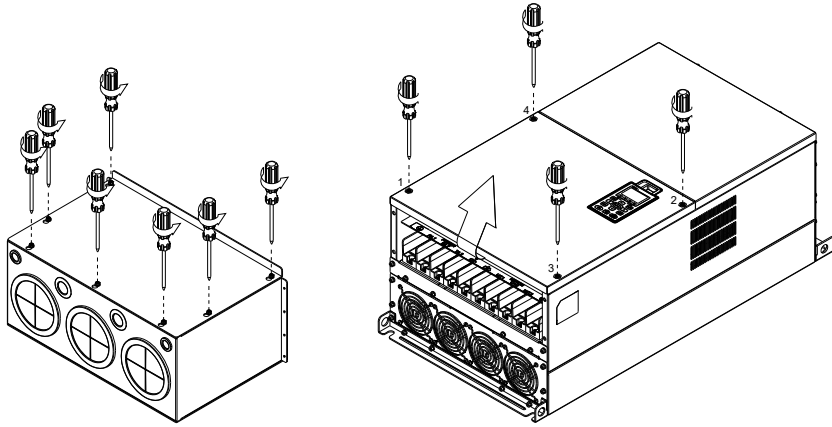

3. Remove the top cover and loosen the screws.  
M5 Screw torque: 24~26 kg-cm / [20.8~22.6 lb-in.] / [2.4~2.5 Nm]  
M8 Screw torque: 100~120 kg-cm / [86.7~104.1 lb-in.] / [9.8~11.8 Nm]

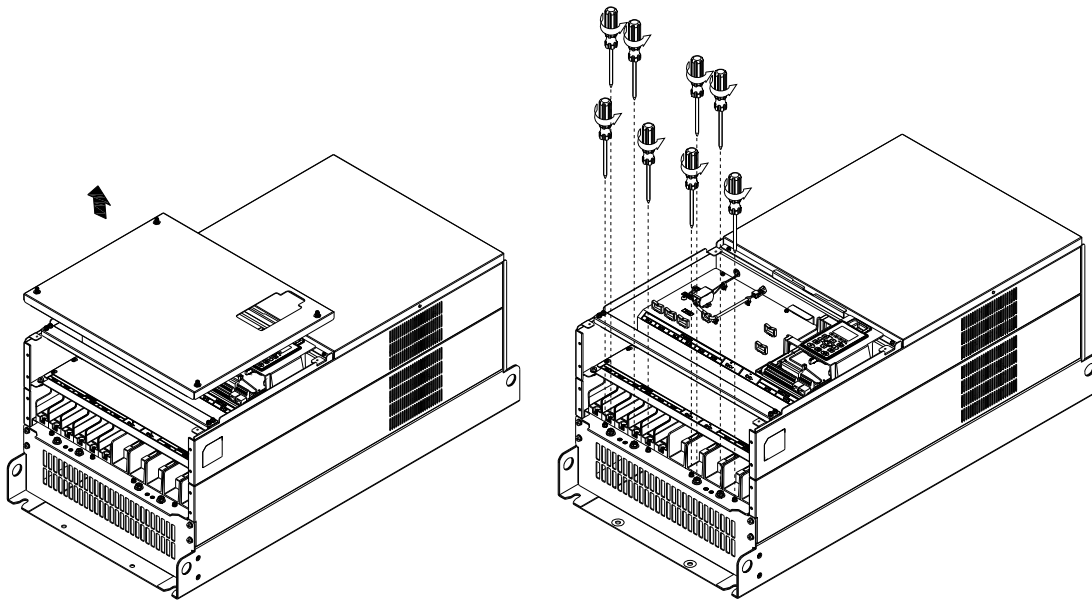

4. Install the conduit box by fastening all the screws shown in the following figure.  
M5 Screw torque: 24~26 kg-cm / [20.8~22.6 lb-in.] / [2.4~2.5 Nm]  
M8 Screw torque: 100~120 kg-cm / [86.7~104.1 lb-in.] / [9.8~11.8 Nm]

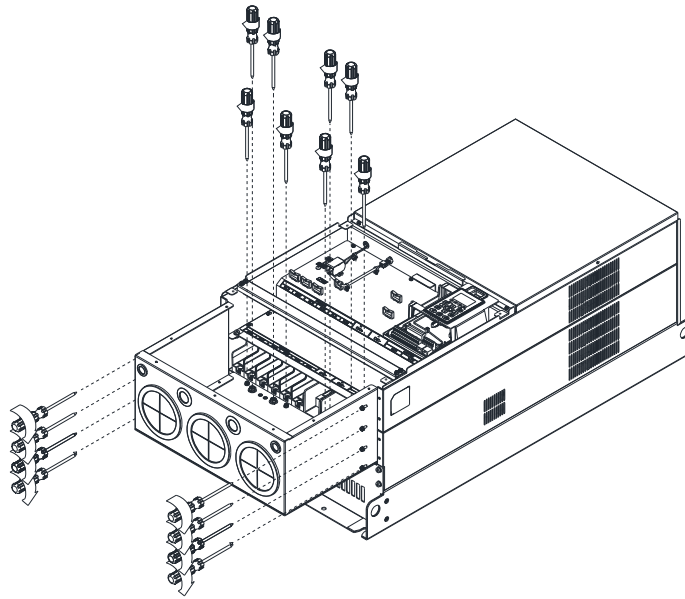

5. Fasten all the screws.  
Screw torque: 24~26 kg-cm / [20.8~22.6 lb-in.] / [2.4~2.5 Nm]

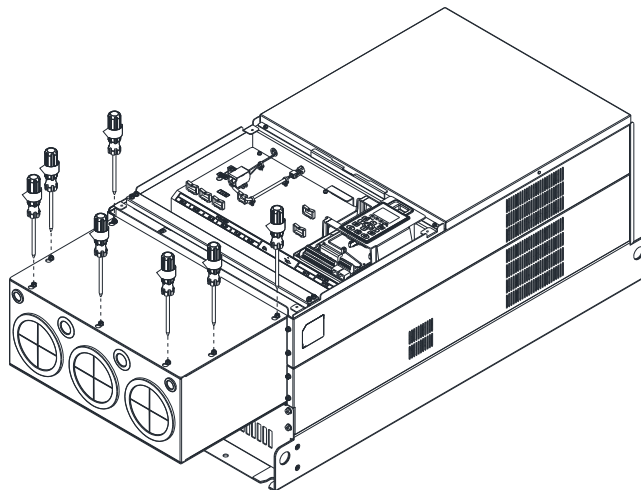



6. Place the cover back to the top and fasten the screws (as shown in the figure).  
Screw torque: 12~15 kg-cm / [10.4~13 lb-in.] / [1.2~1.5 Nm]

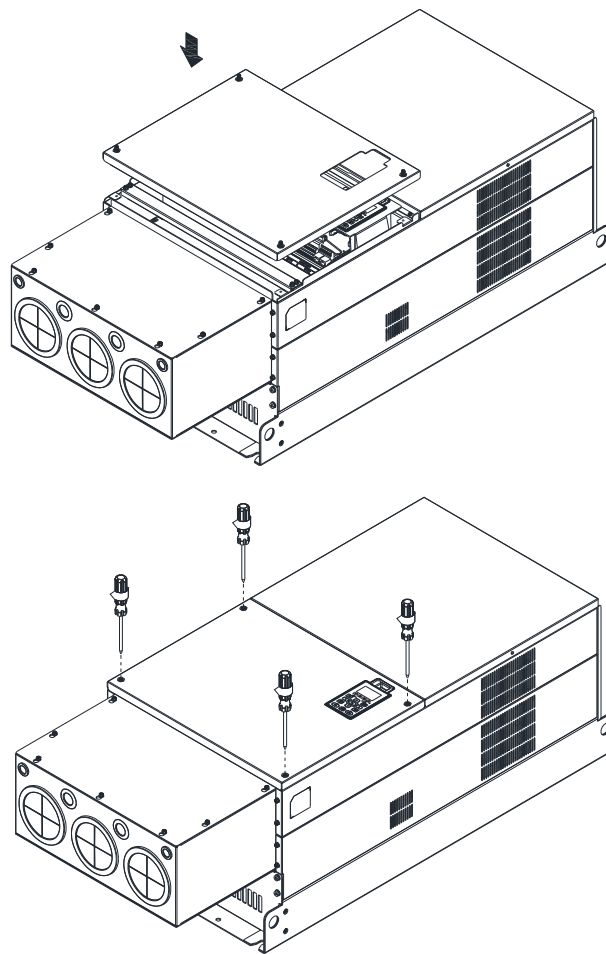

**Frame H****Assembly for Frame H3 (Conduit Box)**

1. Loosen the 3 screws and remove the cover of conduit box H3 as preparation.

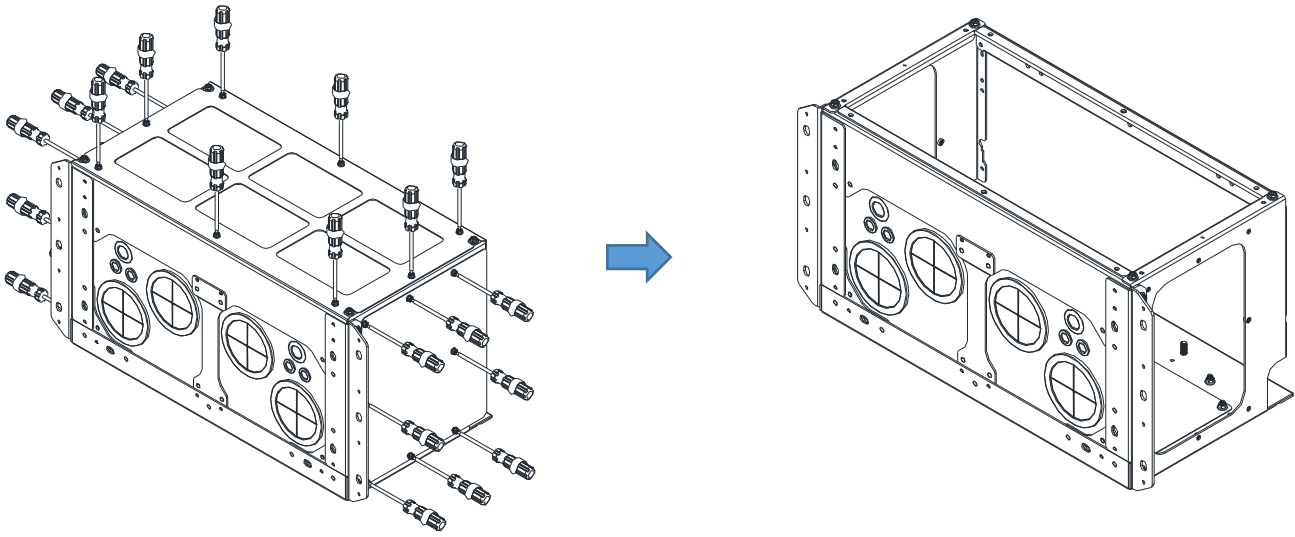

2. Loosen the screws as below figure shown.

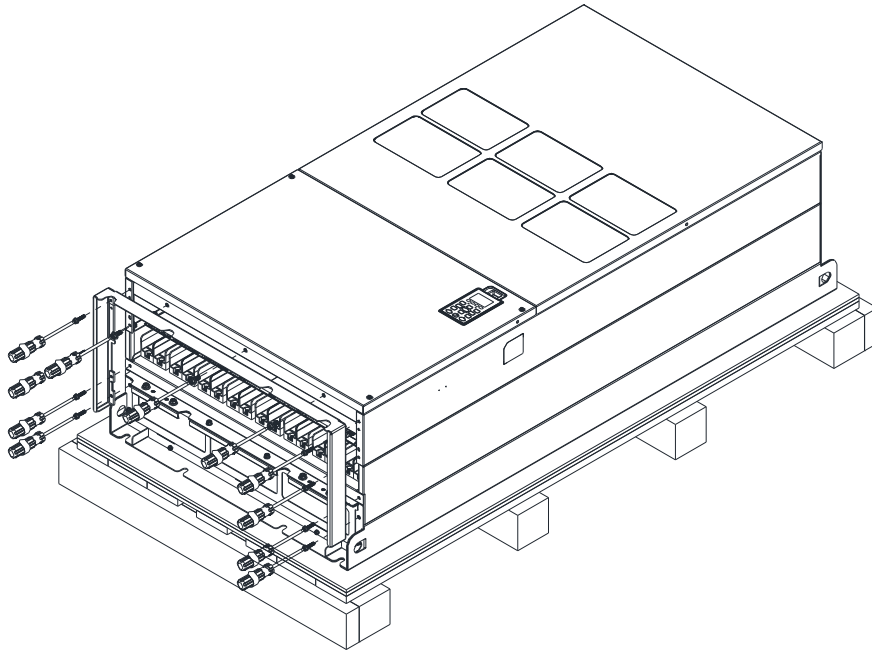

- Fasten the M6 screws to locations shown in the following figure.  
Screw Torque: 35~45 kg-cm / [30.3~39 lb-in.] / [3.4~4.4 Nm]

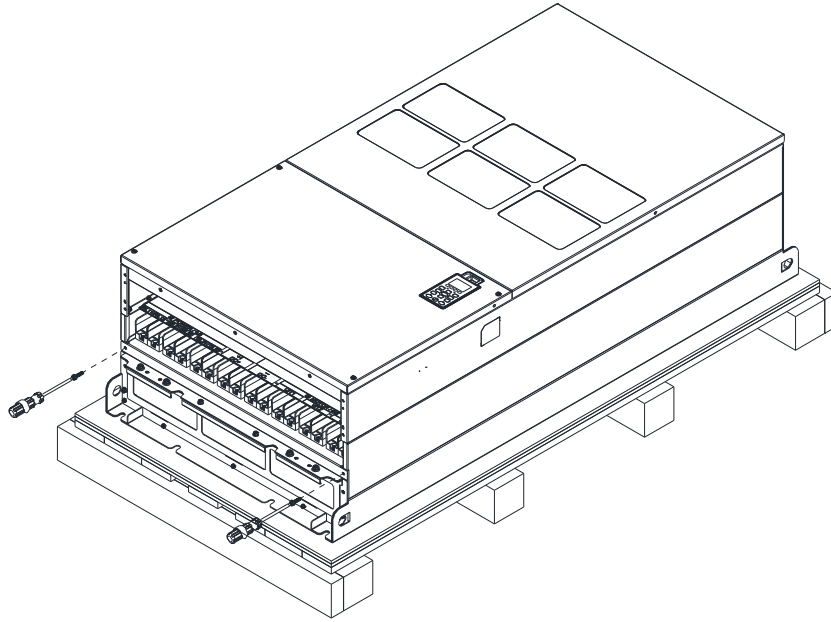

- Install the conduit box by fasten all the screws shown in the following figure.  
Screw 1~6: M6 screw torque: 55~65 kg-cm / [47.7~56.4 lb-in.] / [5.4~6.4 Nm]  
Screw 7~9: M8 screw torque: 100~110 kg-cm / [86.7~95.4 lb-in.] / [9.8~10.8 Nm]  
Screw 10~13: M10 screw torque: 250~300 kg-cm / [216.9~260.3 lb-in.] / [24.5~29.4 Nm]  
Screw 14~17: M8 screw torque: 100~110 kg-cm / [86.7~95.4 lb-in.] / [9.8~10.8 Nm]

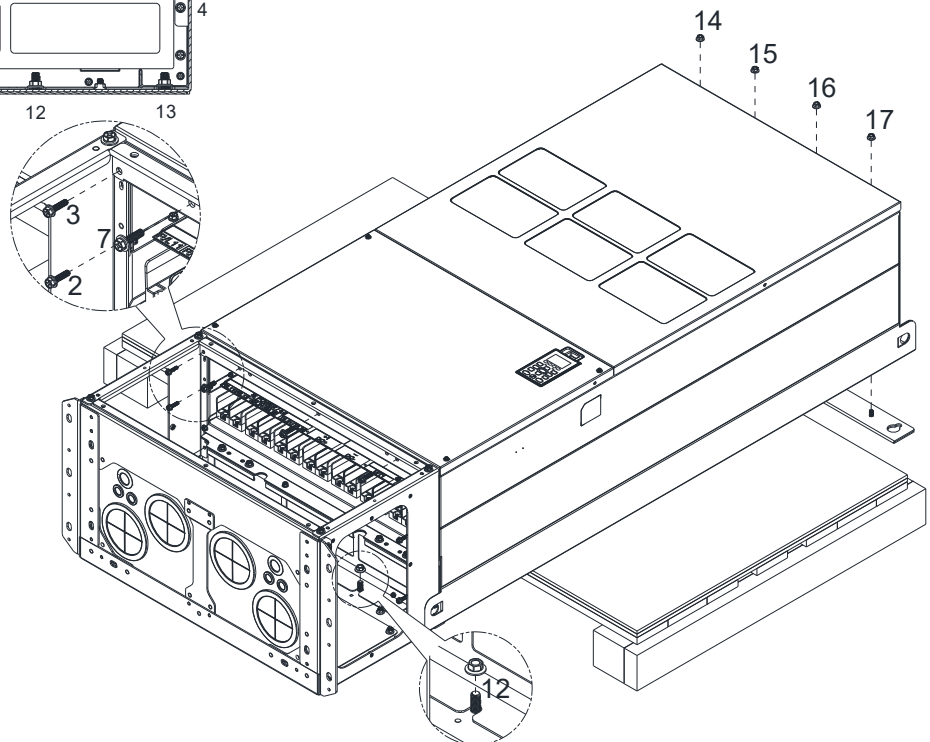
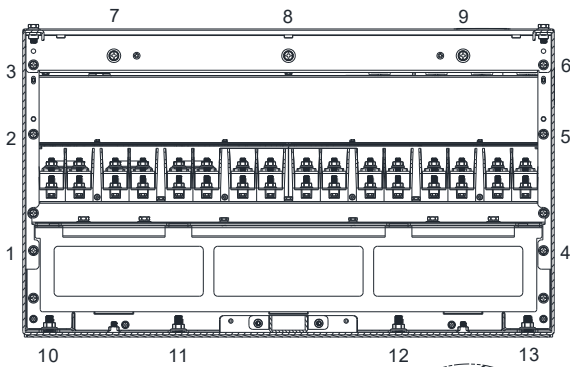

5. Fasten the 3 covers and screws, which were loosen from step 1, to the original location.  
Screw Torque: 35~45 kg-cm / [30.3~39 lb-in.] / [3.4~4.4 Nm]

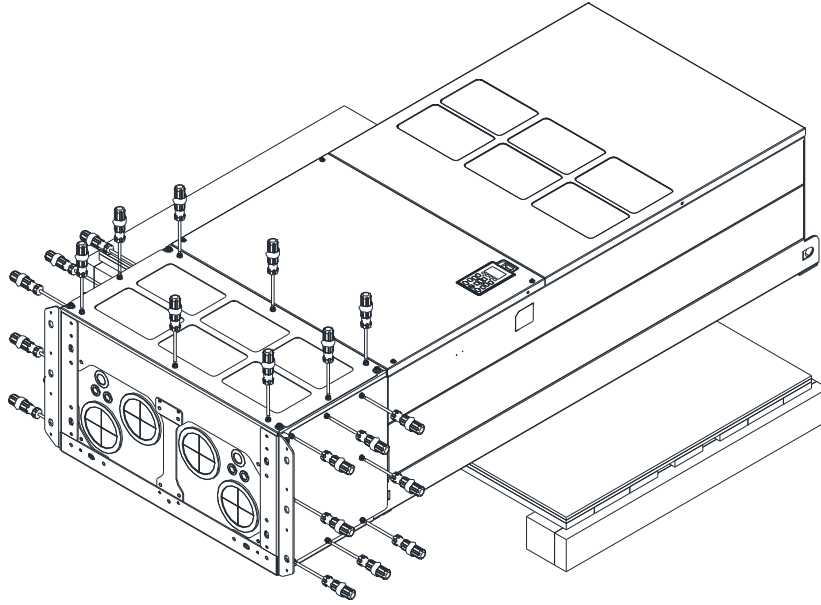

6. Installation complete.

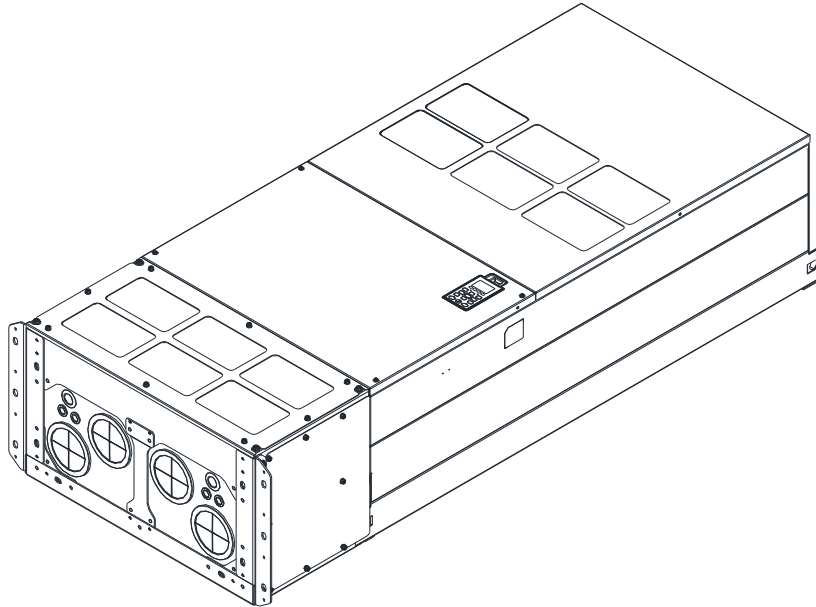

Assembly for Frame H2 (Straight Stand)

1. Loosen the 3 screws and remove the cover of conduit box.

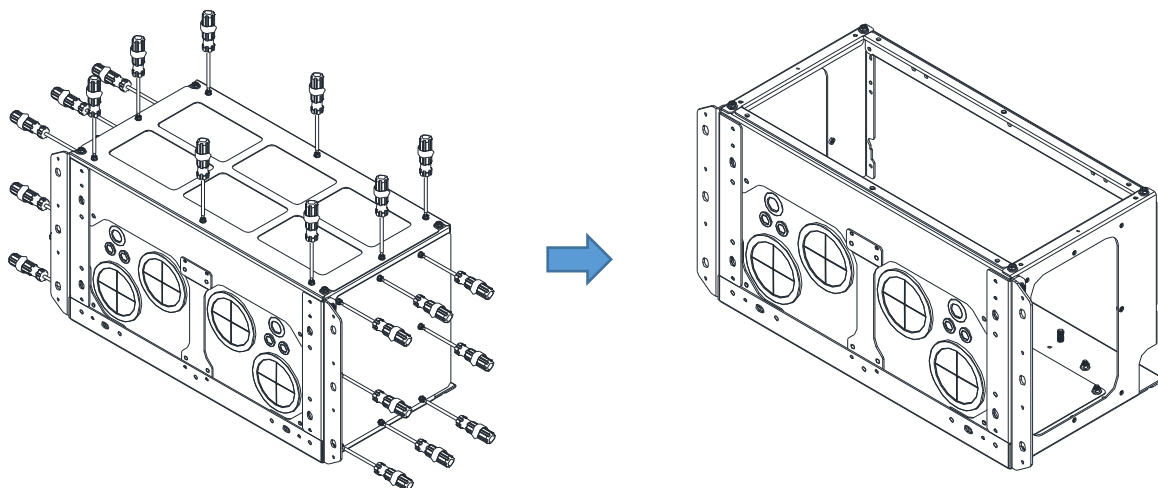

2. Remove the 4 covers of conduit box, and fasten the loosen screws back to the original location.  
Screw Torque: 100~110 kg-cm / [86.7~95.4 lb-in] / [9.8~10.8 Nm]

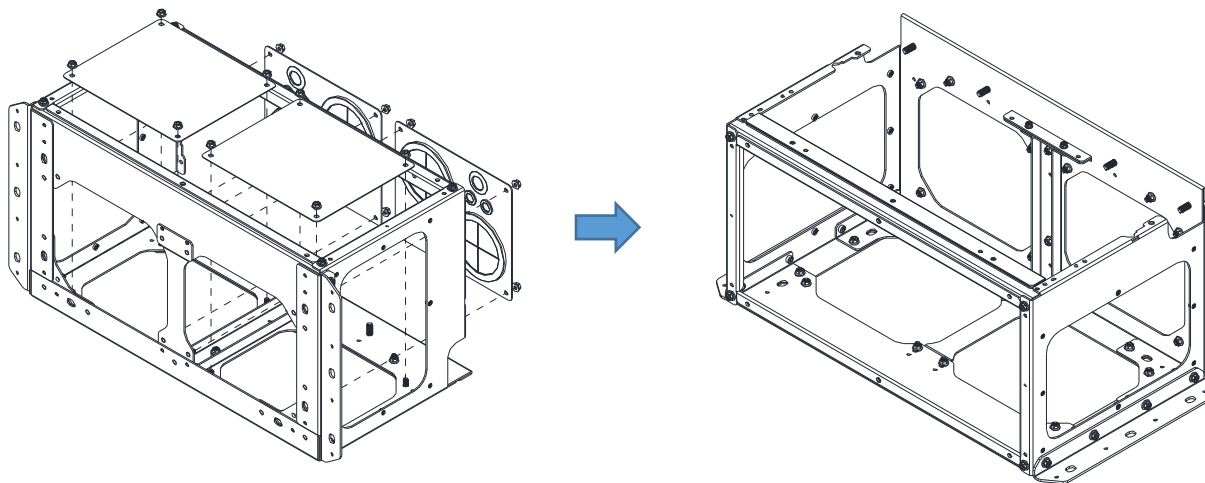

3. Remove the parts and screws as below figure shown.

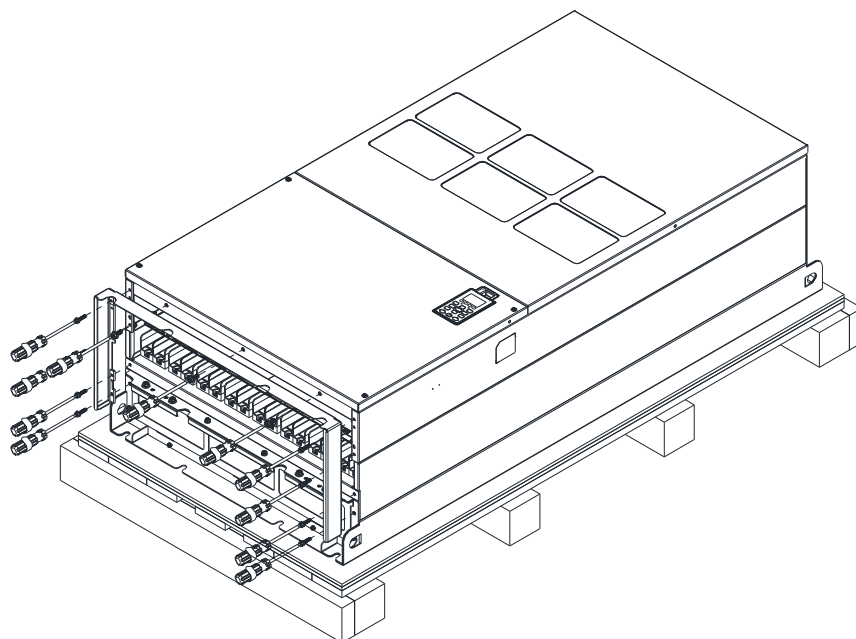

4. Fasten the M6 screws to locations shown in below figure.

Screw Torque: 35~45 kg-cm / [30.3~39 lb-in.] / [3.4~4.4 Nm]

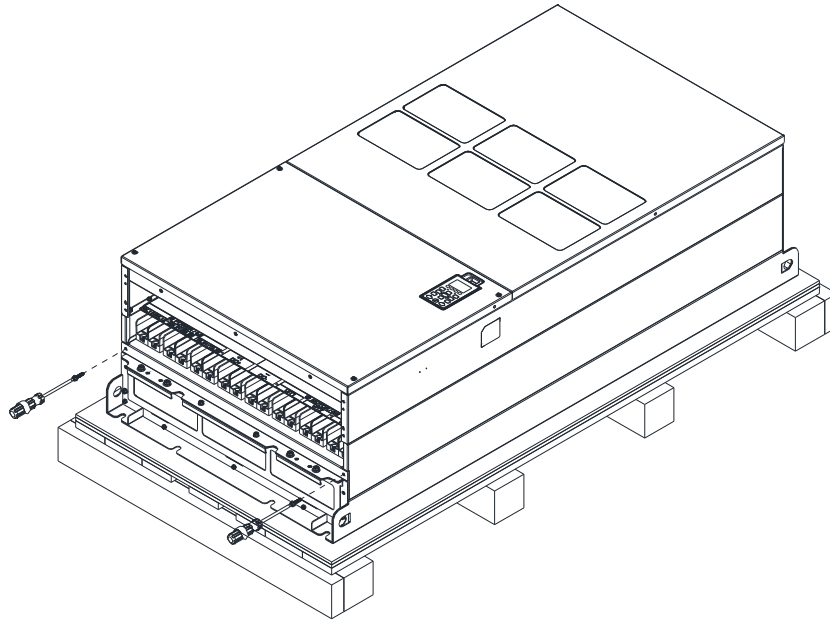

5. Install conduit box and accessories by fasten all the screws shown in the following figure.

Screw 1~6: M6 screw torque: 55~65 kg-cm / [47.7~56.4 lb-in.] / [5.4~6.4 Nm]

Screw 7~9: M8 screw torque: 100~110 kg-cm / [86.7~95.4 lb-in.] / [9.8~10.8 Nm]

Screw 10~13: M10 screw torque: 250~300 kg-cm / [216.9~260.3 lb-in.] / [24.5~29.4 Nm]

Screw 14~17: M8 screw torque: 100~110 kg-cm / [86.7~95.4 lb-in.] / [9.8~10.8 Nm]

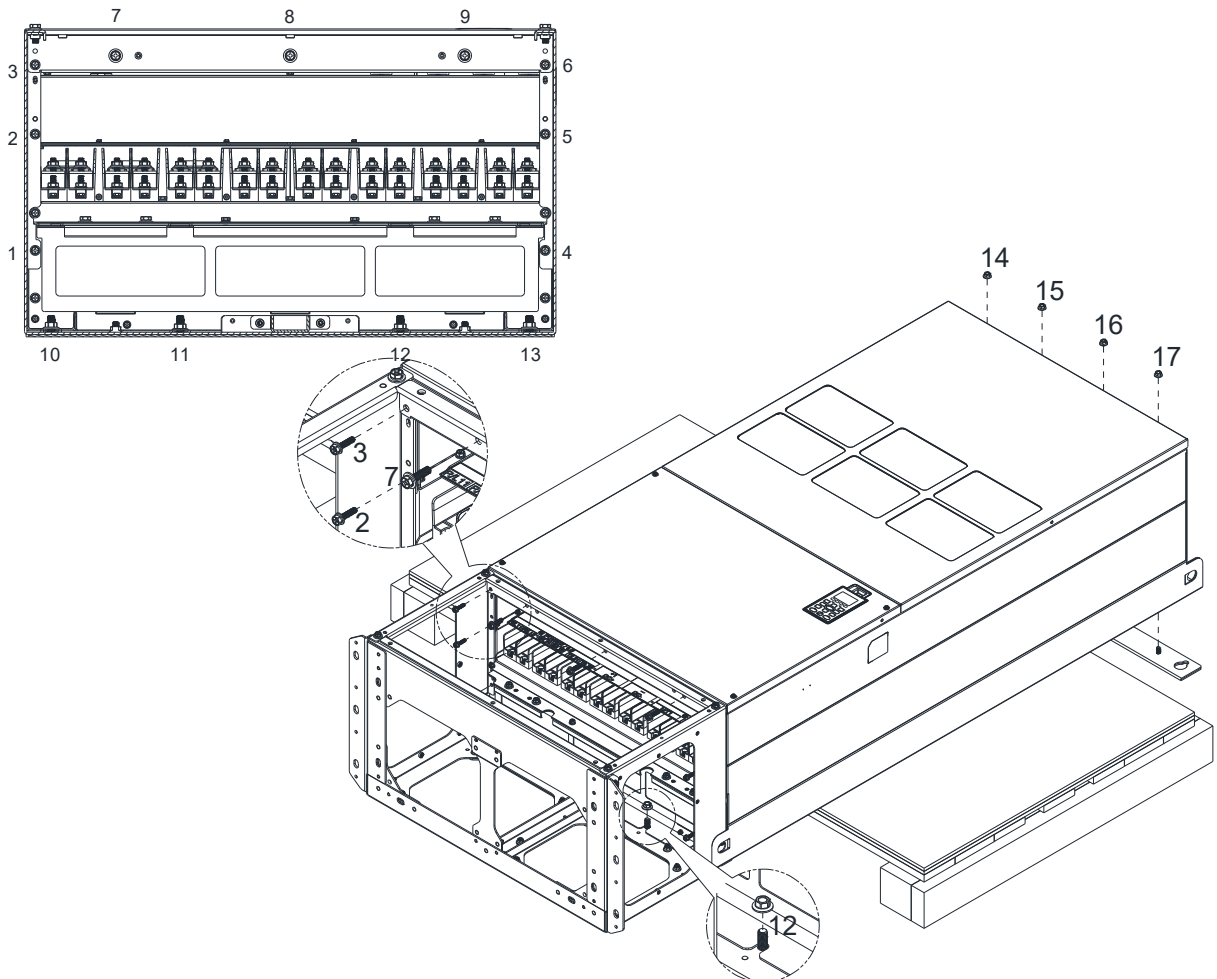

6. Installation complete.

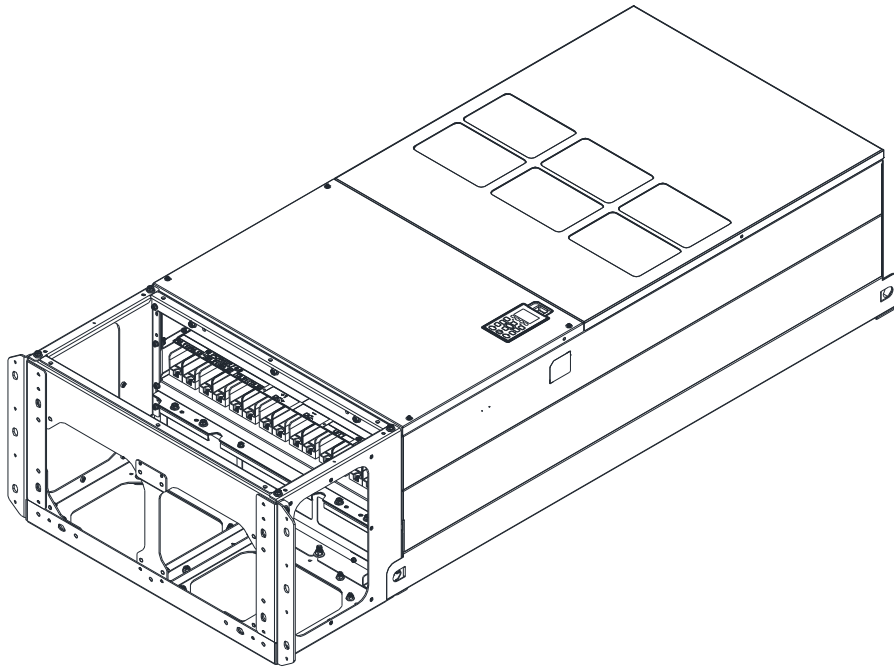

## 7-9 Fan Kit

### ■ Frames of the fan kit

NOTE: The fan does not support hot swap function. For replacement, turn the power off before replacing the fan.

#### Frame A

#### Heat sink Fan Model "MKC-AFKM"

#### Applicable Model

VFD015C23A; VFD022C23A; VFD037C23A;  
VFD022C43A/43E; VFD037C43A/43E;  
VFD040C43A/43E; VFD055C43A/43E;  
VFD015C53A-21; VFD022C53A-21; VFD037C53A-21

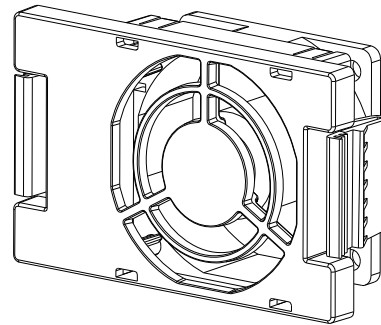

#### Frame B

#### Heat sink Fan Model "MKC-BFKM1"

#### Applicable Model

VFD055C23A; VFD075C43A/43E; VFD055C53A-21;  
VFD075C53A-21; VFD110C53A-21; VFD150C53A-21

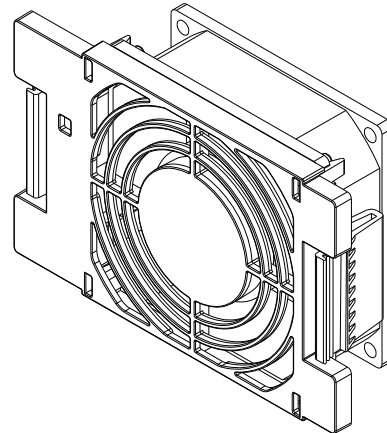

#### Frame B

#### Heat sink Fan Model "MKC-BFKM2"

#### Applicable Model

VFD075C23A; VFD110C23A; VFD110C43A/43E;  
VFD150C43A/43E

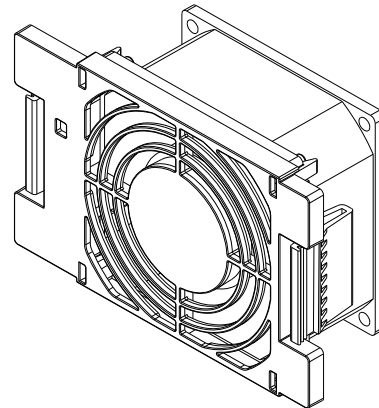

#### Frame B

#### Capacitor Fan Model "MKC-BFKB"

#### Applicable Model

VFD055C23A; VFD075C23A; VFD110C23A;  
VFD075C43A/43E; VFD110C43A/43E;  
VFD150C43A/43E; VFD055C53A-21;  
VFD075C53A-21; VFD110C53A-21; VFD150C53A-21

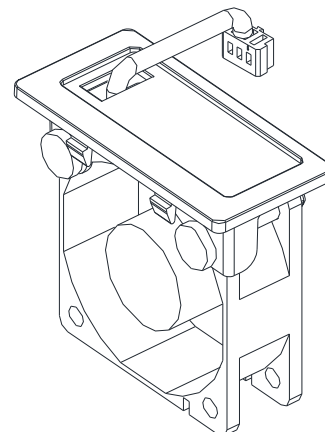



**Frame C**

Applicable Model

VFD150C23A; VFD185C23A; VFD220C23A

Capacitor Fan Model "MKC-CFKB1"

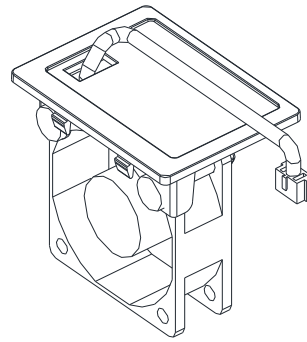

**Frame C**

Applicable Model

VFD185C43A/43E; VFD220C43A/43E;  
VFD300C43A/43E

Capacitor Fan Model "MKC-CFKB2"

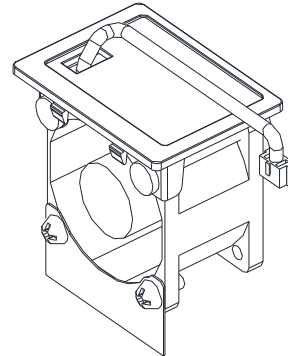

**Frame C**

Following Model use one set of MKC-CFKM:  
VFD185C43A/E; VFD220C43A/E; VFD300C43A

Following Model use two sets of MKC-CFKM:  
VFD150C23A; VFD185C23A; VFD220C23A;  
VFD300C43E

Heat sink Fan "MKC-CFKM"

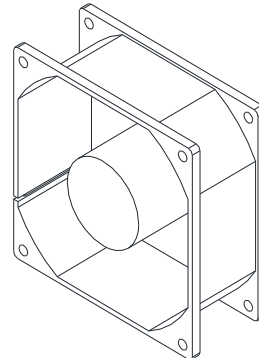

**Frame C**

Applicable Model

VFD185C63B-21; VFD220C63B-21; VFD300C63B-21;  
VFD370C63B-21

Heat sink Fan  
'MKC-CFKM1"

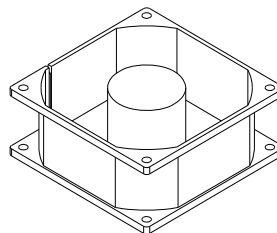

Capacitor Fan  
"MKC-CFKB3"

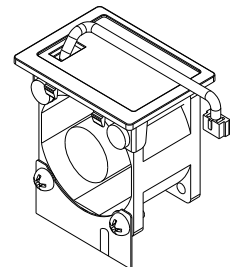

**Frame D0**

Applicable Model

VFD370C43S/43U; VFD450C43S/43U;

Heat sink Fan Model  
"MKC-D0FKM"

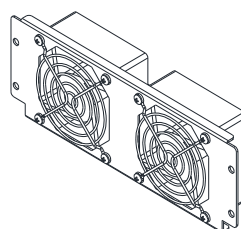

Capacitor Fan Model  
"MKC-DFKB"

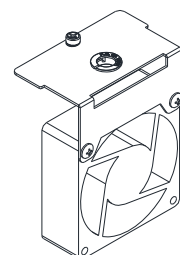

**Frame D**

Applicable Model

VFD300C23A/23E; VFD370C23A/23E;  
 VFD550C43A/43E; VFD750C43A/43E;  
 VFD450C63B-00; VFD550C63B-00;  
 VFD450C63B-21; VFD550C63B-21

Heat sink Fan Model  
 "MKC-DFKM"

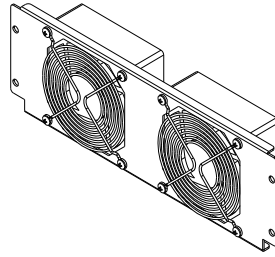

Capacitor Fan Model  
 "MKC-DFKB"

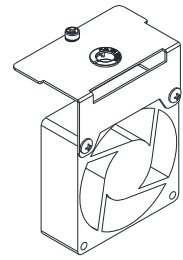

**Frame E**

Applicable Model

VFD450C23A/23E; VFD550C23A/23E

Heat sink Fan Model "MKC-EFKM1"

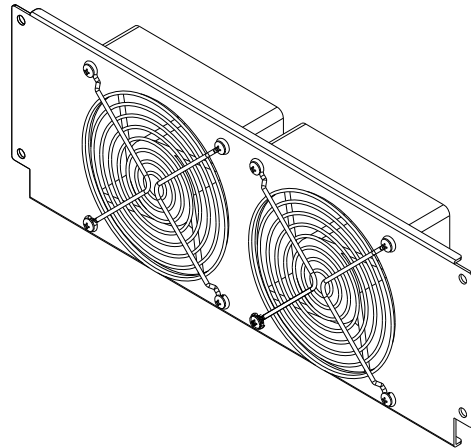

**Frame E**

Applicable Model

VFD750C23A/23E; VFD900C43A/43E;  
 VFD1100C43A/43E

Heat sink Fan Model "MKC-EFKM2"

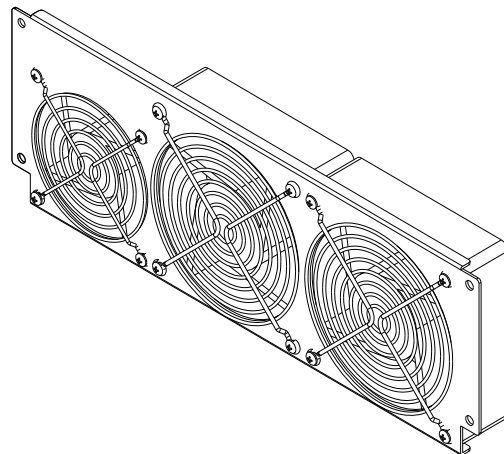

**Frame E**

Applicable Model

VFD750C63B-00; VFD900C63B-00;  
 VFD1100C63B-00; VFD1320C63B-00;  
 VFD750C63B-21; VFD900C63B-21;  
 VFD1100C63B-21; VFD1320C63B-21

Heat Sink Fan Model "MKC-EFKM3"

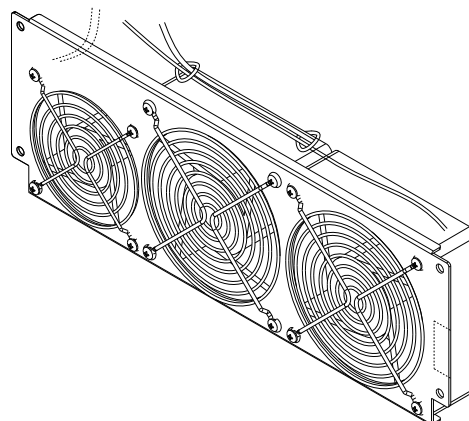

**Frame E**

**Capacitor Fan Model “MKC-EFKB”**

**Applicable Model**

VFD450C23A/23E; VFD550C23A/23E;  
 VFD750C23A/23E; VFD900C43A/43E;  
 VFD1100C43A/43E; VFD750C63B-00;  
 VFD750C63B-21; VFD900C63B-00;  
 VFD1100C63B-00; VFD1320C63B-00;  
 VFD900C63B-21; VFD1100C63B-21;  
 VFD1320C63B-21

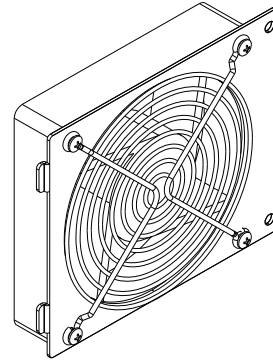

**Frame F**

**Heat sink Fan Model “MKC-FFKM”**

**Applicable Model**

VFD900C23A/23E; VFD1320C43A/43E;  
 VFD1600C43A/43E; VFD1600C63B-00;  
 VFD2000C63B-00; VFD1600C63B-21;  
 VFD2000C63B-21

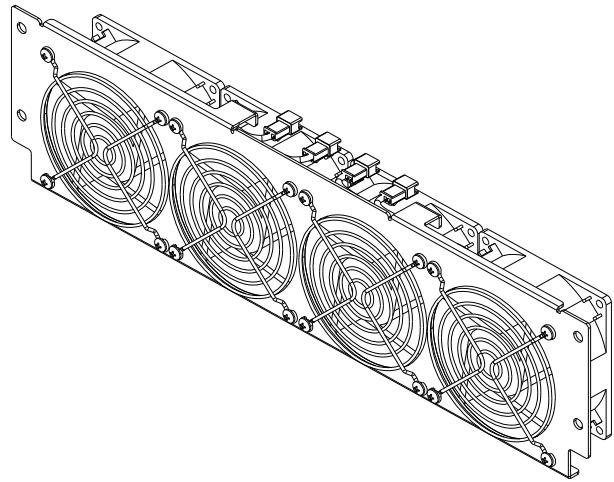

**Frame F**

**Capacitor Fan Model “MKC-FFKB”**

**Applicable Model**

VFD900C23A/23E; VFD1320C43A/43E;  
 VFD1600C43A/43E; VFD1600C63B-00;  
 VFD2000C63B-00; VFD1600C63B-21;  
 VFD2000C63B-21

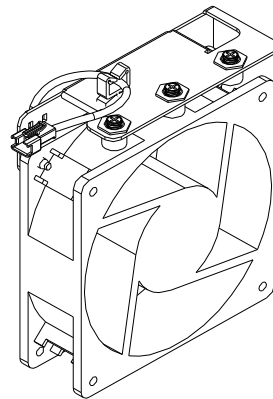

**Frame G**

**Heat sink Fan Model “MKC-GFKM”**

**Applicable Model**

VFD1850C43A/43E; VFD2200C43A/43E;  
 VFD2500C63B-00; VFD3150C63B-00;  
 VFD2500C63B-21; VFD3150C63B-21

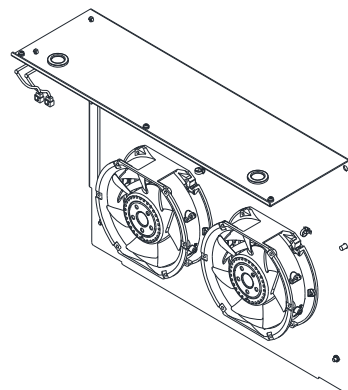

**Frame H****Heat sink Fan Model "MKC-HFKM"****Applicable Model**

Following models use 2 sets of MKC-HFKM fan kit.

VFD2800C43A/43E; VFD3150C43A/43E;  
 VFD3550C43A/43E; VFD4500C43A/43E;  
 VFD2800C43E-1; VFD3150C43E-1; VFD3550C43E-1;  
 VFD4500C43E-1

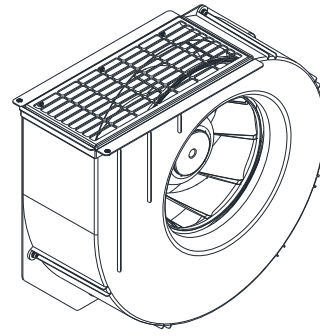
**Frame H****Heat sink Fan Model "MKC-HFKM1"****Applicable Model**

Following models use two sets of MKC-HFKM1:

VFD4000C63B-00; VFD4000C63B-21

Following models use three sets of MKC-HFKM1:

VFD4500C63B-00; VFD4500C63B-21;

VFD5600C63B-00; VFD5600C63B-21;

VFD6300C63B-00; VFD6300C63B-21

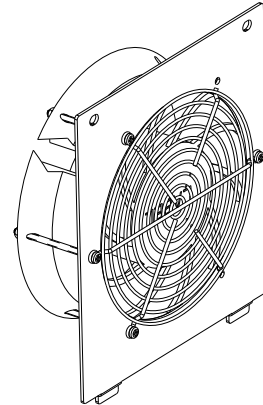

**■ Fan Removal**

**Frame A**

**Model "MKC-AFKM" : Heat Sink Fan**

**Applicable model**

VFD015C23A; VFD022C23A; VFD037C23A; VFD022C43A/43E; VFD037C43A/43E; VFD040C43A/43E; VFD055C43A/43E; VFD015C53A-21; VFD022C53A-21; VFD037C53A-21

1. Refer to Figure 1, press the tabs on both side of the fan to successfully remove the fan.
2. Disconnect the power terminal before removing the fan. (As shown below.)

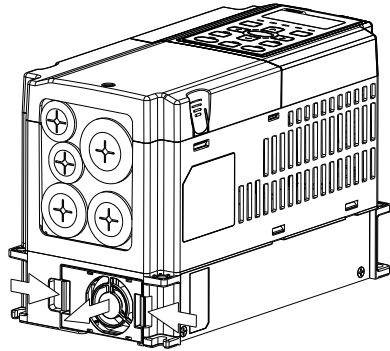

Figure 1

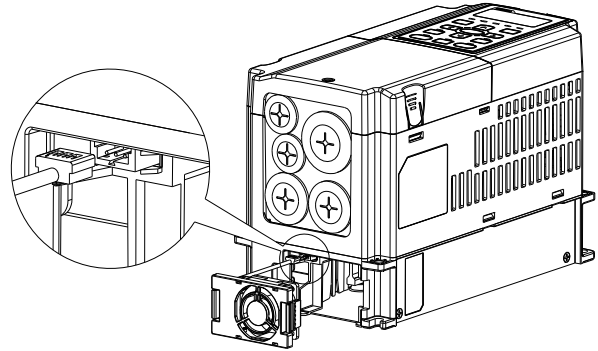

Figure 2

**Frame B**

**Model "MKC-BFKM1" Heat Sink Fan**

**Applicable model**

VFD055C23A; VFD075C43A/43E; VFD055C53A-21; VFD075C53A-21; VFD110C53A-21; VFD150C53A-21

1. Refer to Figure 1, press the tab on both side of the fan to successfully remove the fan.
2. Disconnect the power terminal before removing the fan. (As shown below.)

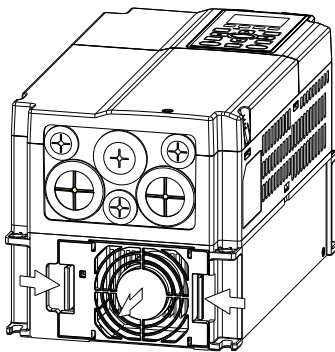

Figure 1

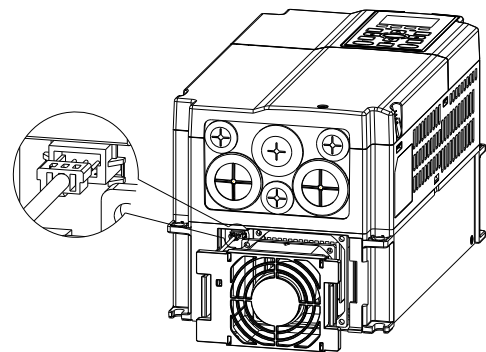

Figure 2

**Frame B**

**Model "MKC-BFKM2" Heat Sink Fan**

**Applicable model**

VFD075C23A; VFD110C23A; VFD110C43A/43E; VFD150C43A/43E

1. Refer to Figure 1, press the tab on both side of the fan to successfully remove the fan.
2. Disconnect the power terminal before removing the fan. (As shown below.)

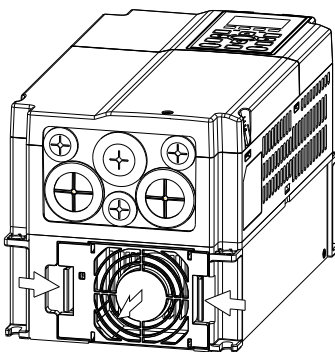

Figure 1

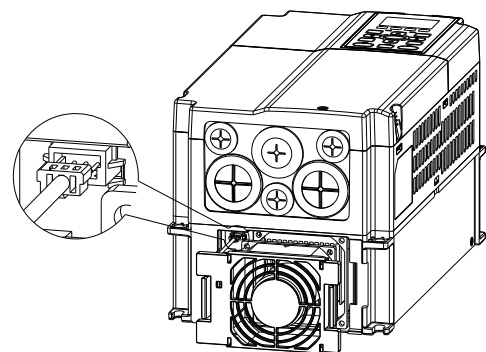

Figure 2

## Frame B

## Model "MKC-BFKB" Capacitor Fan

## Applicable model

VFD055C23A; VFD075C23A; VFD110C23A; VFD075C43A/43E; VFD110C43A/43E; VFD150C43A/43E; VFD055C53A-21; VFD075C53A-21; VFD110C53A-21; VFD150C53A-21

Disconnect fan power and pull out the fan by using flathead screwdriver. (As shown in the larger picture)

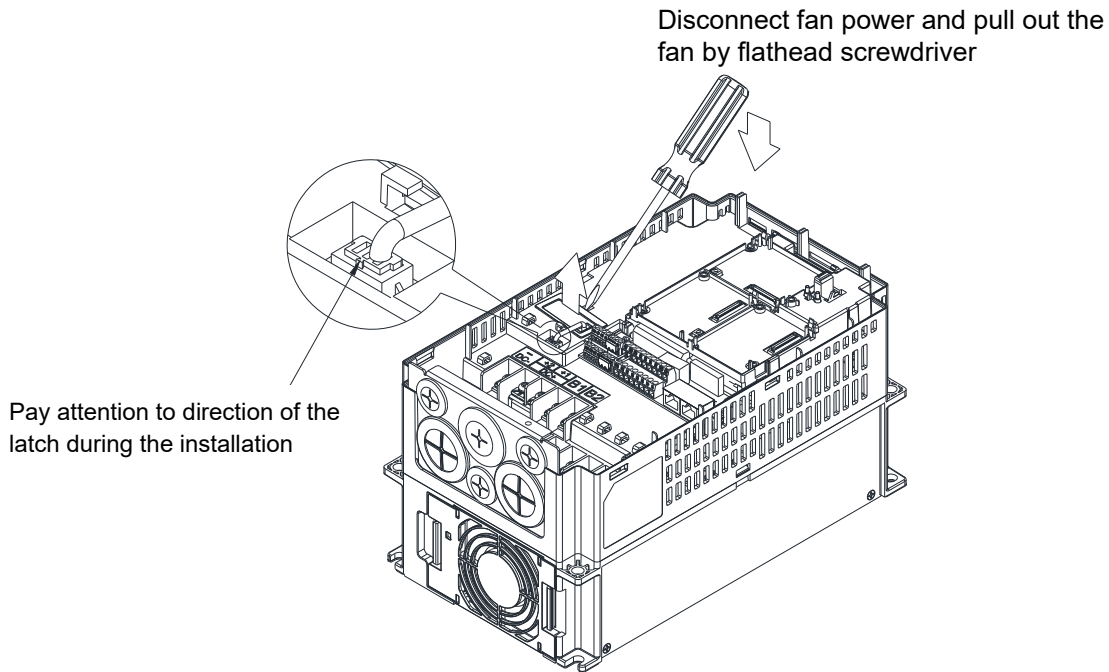

## Frame C

## Model "MKC-CFKM / MKC-CFKM1" Heat Sink Fan

## Applicable model

Single fan kit applicable models (only fan kit 1 is required to be installed):

VFD185C43A/E; VFD220C43A/E; VFD300C43A; VFD185C63B-21; VFD220C63B-21; VFD300C63B-21; VFD370C63B-21

Duo fan kit applicable models (both fan kit 1 and 2 are required to be installed):

VFD150C23A; VFD185C23A; VFD220C23A; VFD300C43E

1. (As shown Figure 1) Before removing the fan, remove the cover by using a slotted screwdriver.

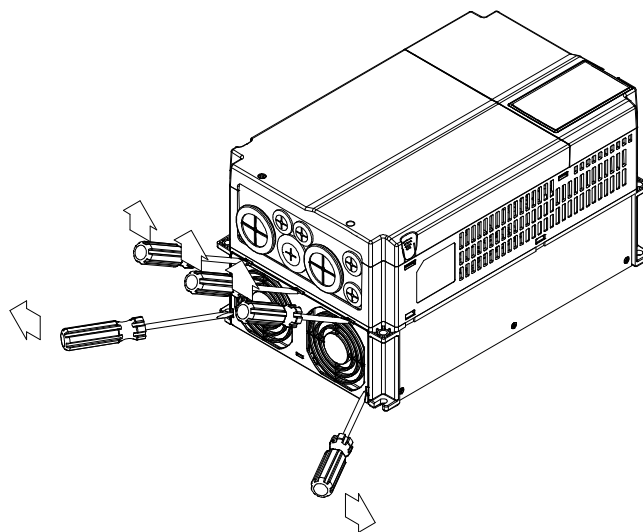

Figure 1

2. (As shown in Figure 2), remove the power connector, loosen the screw and remove the fan kit. When installing the fan kit, have the label on the fan kit facing inside of the motor drive. Screw's torque force: 10~12 kg-cm / [8.7~10.4 lb-in.] / [1.0~1.2 Nm]

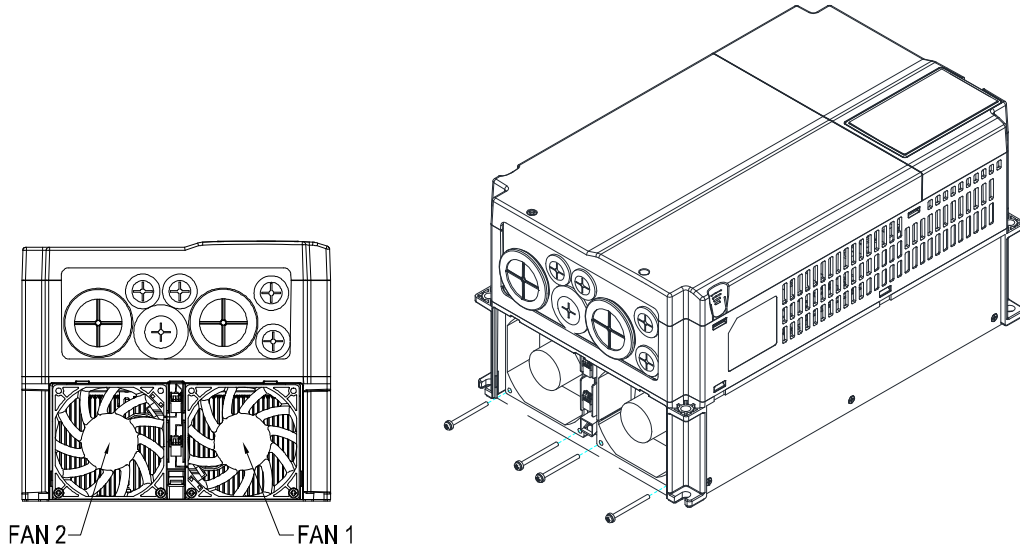

Figure 2

**Frame C**

**Model "MKC-CFKB1" Capacitor Fan**

Applicable model  
VFD150C23A; VFD185C23A; VFD220C23A

**Model "MKC-CFKB2" Capacitor Fan**

Applicable model  
VFD185C43A/43E; VFD220C43A/43E; VFD300C43A/43E

**Model "MKC-CFKB3" Capacitor Fan**

Applicable model  
VFD185C63B-21; VFD220C63B-21; VFD300C63B-21; VFD370C63B-21

Disconnect fan power and pull out the fan by using flathead screwdriver. (As shown in the larger picture)

Disconnect fan power and pull out the fan by flathead screwdriver.

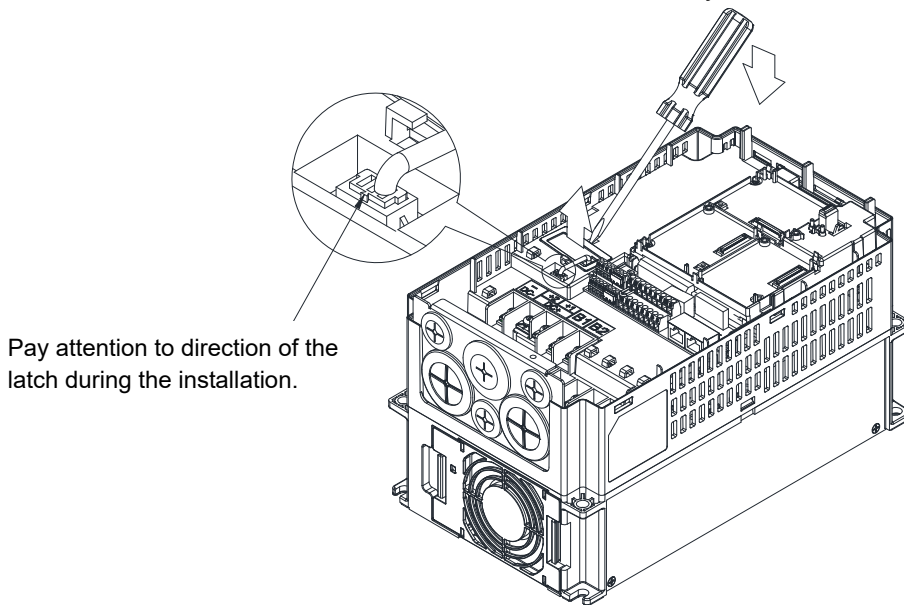

Figure 1



## Frame D0

## Model "MKC-DFKB" Capacitor Fan

Applicable model

VFD370C43S/43U; VFD450C43S/43U

- Loosen screw 1 and screw 2, press the tab on the right and left to remove the cover, follow the direction the arrows indicate. Press on top of digital keypad to properly remove it. Screw 1, 2 Torque: 12~15 kg-cm / [10.4~13 lb-in.] / [1.2~1.5 Nm]
- (Figure 2) Loosen screw 3, press the tab on the right and the left to remove the cover. Screw 3 Torque: 6~8 kg-cm / [5.2~6.9 lb-in.] / [0.6~0.8 Nm]

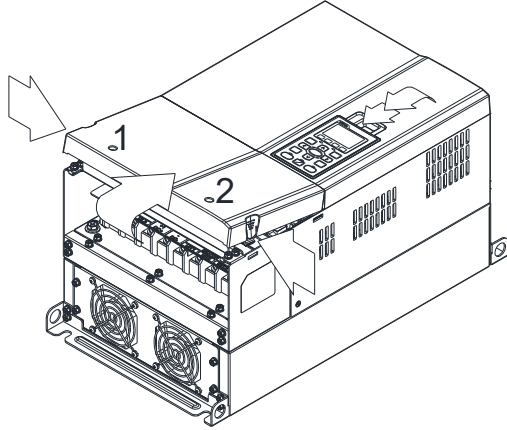

Figure 1

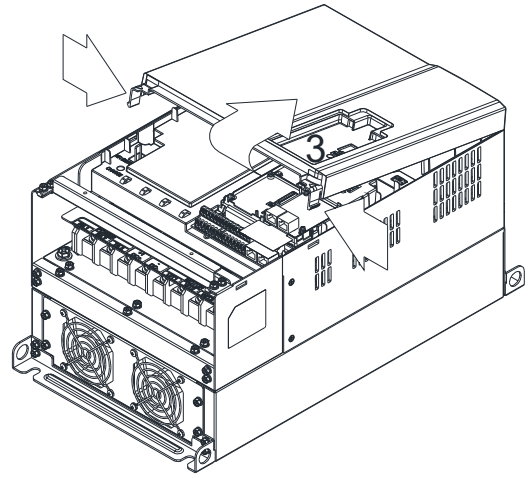

Figure 2

- Loosen screw 4 (figure 3) and disconnect fan power and pull out the fan. (As shown in the enlarged picture 3) Screw 4 Torque: 10~12 kg-cm / [8.7~10.4 lb-in.] / [1.0~1.2 Nm]

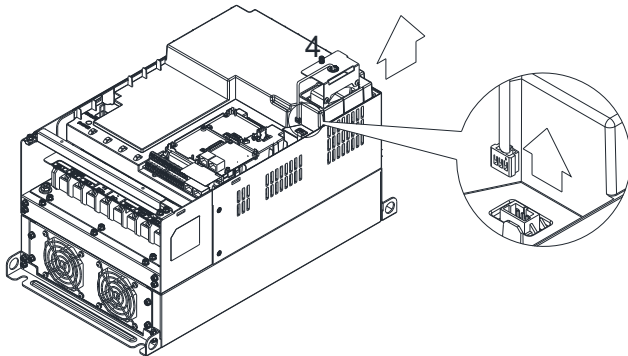

Figure 3

## Frame D0

## Model "MKC-D0FKM" Heat Sink Fan

Applicable model

VFD370C43S/43U; VFD450C43S/43U

- Loosen the screw and remove the fan kit. Screw torque: 24~26 kg-cm / [20.8~22.6 lb-in.] / [2.4~2.5 Nm]
- (As shown Figure 1) Before pulling out the fan, make sure the fan power is disconnected.

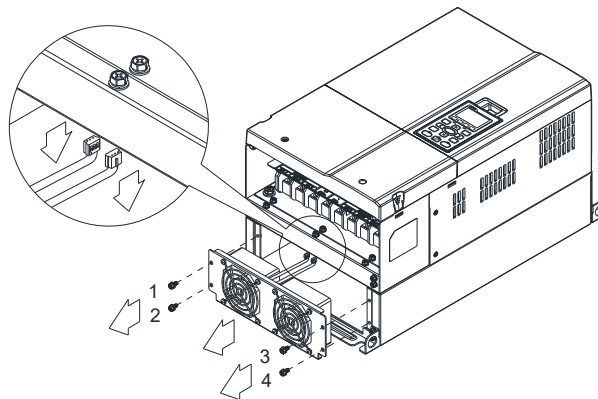

Figure 1



Frame D

Model "MKC-DFKB" Capacitor Fan

Applicable model

VFD300C23A/23E; VFD370C23A/23E; VFD550C43A/43E; VFD750C43A/43E; VFD450C63B-00; VFD550C63B-00; VFD450C63B-21; VFD550C63B-21

1. (Figure 1) Loosen screw 1 and screw 2, press the tab on the right and the left to remove the cover, follow the direction the arrows indicate in the following figure. Press on the top of digital keypad to properly remove it. Screw 1, 2 Torque: 12~15 kg-cm / [10.4~13 lb-in.] / [1.2~1.5 Nm]
2. (Figure 2) Loosen screw 3 & 4, press the tab on the right and the left to remove the cover. Screw 3, 4 Torque: 6~8 kg-cm / [5.2~6.9 lb-in.] / [0.6~0.8 Nm]

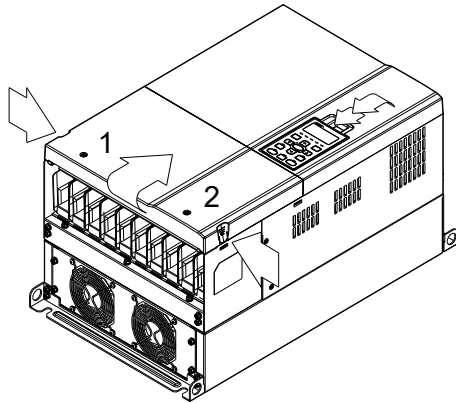

Figure 1

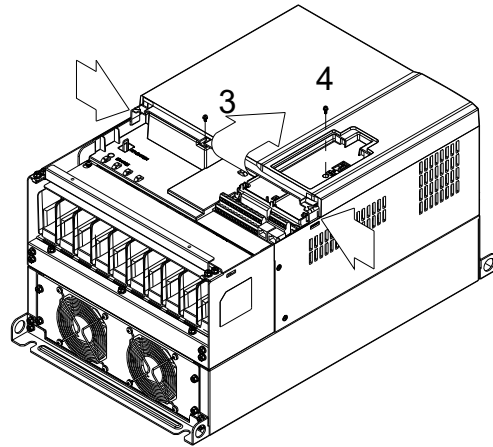

Figure 2

3. Loosen screw 5 (figure 3) and disconnect fan power and pull out the fan. (As shown in the enlarged picture 3) Screw 5 Torque: 10~12 kg-cm / [8.6~10.4 lb-in.] / [1.0~1.2 Nm]

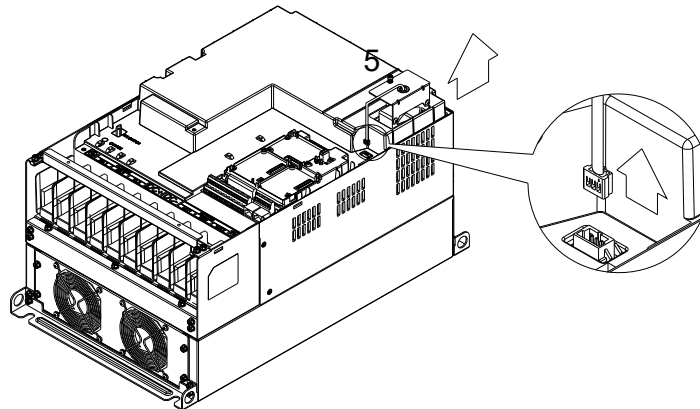

Figure 3

Frame D

Model "MKC-DFKM" Heat Sink Fan

Applicable model

VFD300C23A/23E; VFD370C23A/23E; VFD550C43A/43E; VFD750C43A/43E; VFD450C63B-00; VFD550C63B-00; VFD450C63B-21; VFD550C63B-21

1. Loosen the screw and remove the fan kit. Screw torque: 24~26 kg-cm / [20.8~22.6 lb-in.] / [2.4~2.5 Nm]
2. (As shown Figure 1) Before removing the fan, remove the cover by using a slotted screwdriver.

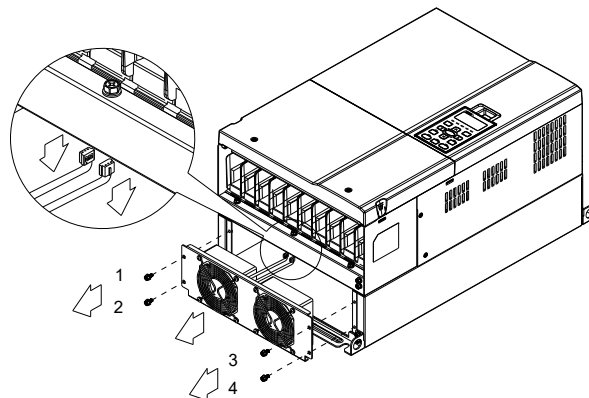

Figure 1

**Frame E****Applicable model**

Applicable for MKC-EFKM1: VFD450C23A/23E; VFD550C23A/23E

Applicable for MKC-EFKM2: VFD750C23A/23E; VFD900C43A/43E; VFD1100C43A/43E

Applicable for MKC-EFKM3: VFD750C63B-00; VFD900C63B-00; VFD1100C63B-00; VFD1320C63B-00; VFD750C63B-21; VFD900C63B-21; VFD1100C63B-21; VFD1320C63B-21

Applicable for MKC-EFKB: VFD450C23A/23E; VFD550C23A/23E; VFD750C23A/23E; VFD900C43A/43E; VFD1100C43A/43E; VFD750C63B-00; VFD750C63B-21; VFD900C63B-00; VFD900C63B-21; VFD1100C63B-00; VFD1100C63B-21; VFD1320C63B-00; VFD1320C63B-21

**Model "MKC-EFKM1" Heat Sink Fan**

1. Loosen screw 1~4 (figure 1) and disconnect fan power and pull out the fan. (As shown in the enlarged picture 3) Screw1~4 Torque: 24~26 kg-cm / [20.8~22.6 lb-in.] / [2.4~2.5 Nm]

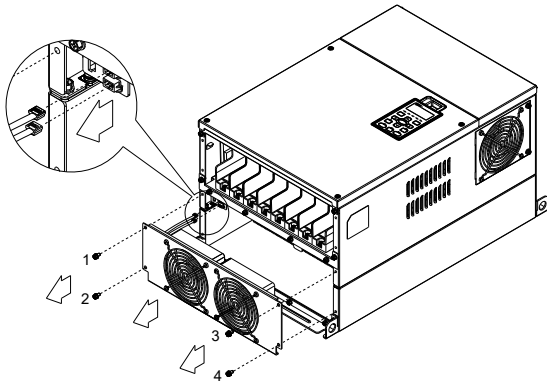

Figure 1

**Model "MKC-EFKM2" / "MKC-EFKM3" Heat Sink Fan**

1. Loosen screw 1~4 (figure 2) and disconnect fan power and pull out the fan. (As shown in the enlarged picture 3) Screw1~4 Torque: 24~26 kg-cm / [20.8~22.6 lb-in.] / [2.4~2.5 Nm]

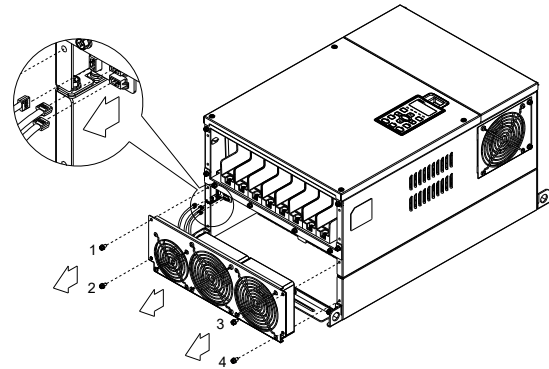

Figure 2

**Model "MKC-EFKB" Capacitor Fan**

1. Loosen screw 1~2 (figure 3) and disconnect fan power and pull out the fan. (As shown in the enlarged picture 3) Screw1~2 Torque: 24~26 kg-cm / [20.8~22.6 lb-in.] / [2.4~2.5 Nm]

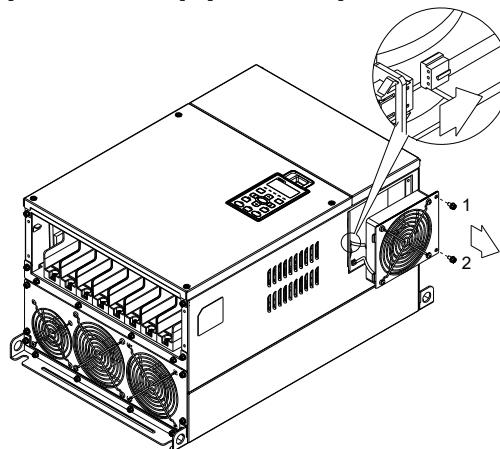

Figure 3

**Frame F**

Applicable model

VFD900C23A/23E; VFD1320C43A/43E; VFD1600C43A/43E; VFD1600C63B-00; VFD2000C63B-00; VFD1600C63B-21; VFD2000C63B-21

**Fan model "MKC-FFKM" Heat Sink Fan**

Loosen the screws and plug out the power of fan before removing (figure 1).  
Screw torque: 24~26 kg-cm / [20.8~22.6 lb-in.] / [2.4~2.5 Nm]

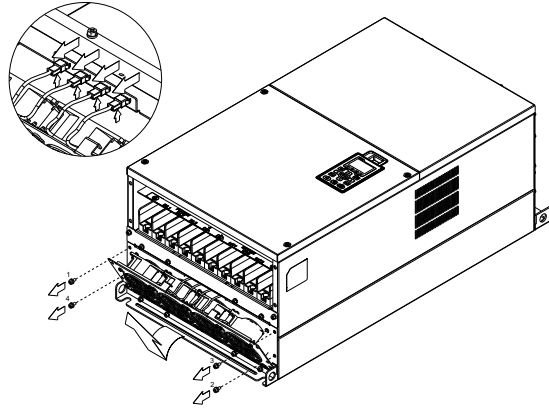

Figure 1

**Fan model "MKC-FFKB" Capacitor Fan**

1. Loosen the screw (figure 1) and removes the cover.  
Screw torque: 12~15 kg-cm / [10.4~13 lb-in.] / [1.2~1.5 Nm]
2. Loosen the screw (figure 2) and removes the cover.  
Screw torque: 24~26 kg-cm / [20.8~22.6 lb-in.] / [2.4~2.5 Nm]

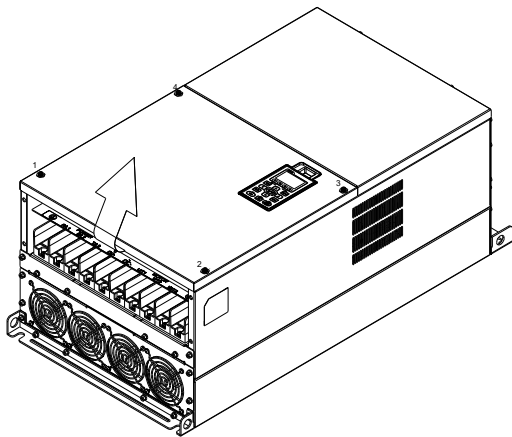

Figure 1

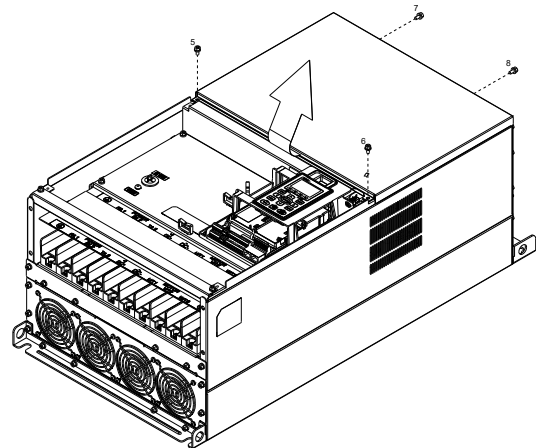

Figure 2

3. Loosen the screws and remove the fan. (figure 3 and figure 4) Screw torque: 24~26 kg-cm / [20.8~22.6 lb-in.] / [2.4~2.5 Nm]

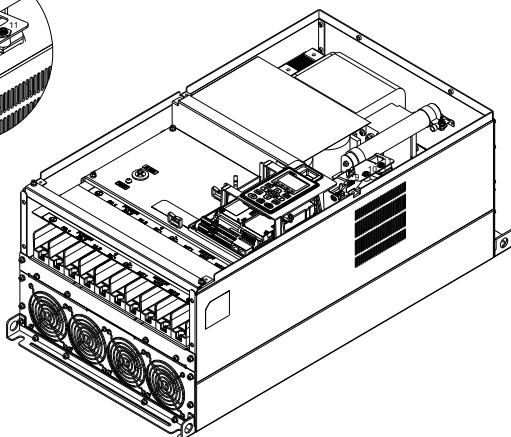
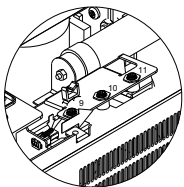

Figure 3

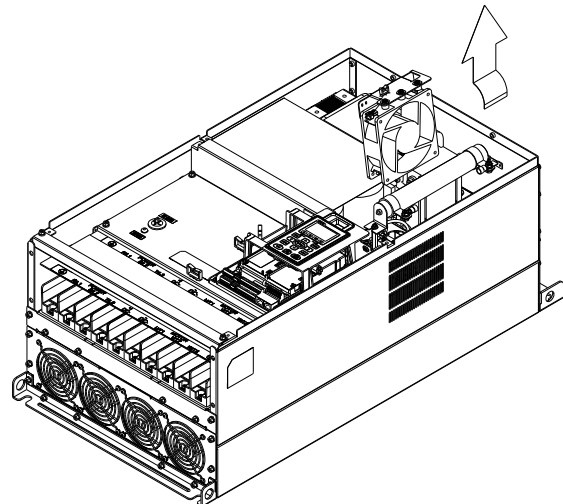

Figure 4

**Frame G**

**Applicable model**

VFD1850C43A/43E; VFD2200C43A/43; VFD2500C63B-00; VFD3150C63B-00; VFD2500C63B-21; VFD3150C63B-21

**Fan model "MKC-GFKM" Heat Sink Fan**

1. Loosen the screw (figure 1) and remove the cover.  
Screw torque: 12~15 kg-cm / [10.4~13.1 lb-in.] / [1.2~1.5 Nm]

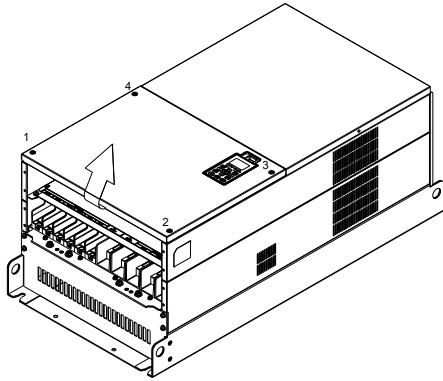

Figure 1

2. For 1~8 shown in the figure 2: Loosen the screws  
Screw torque: 35~40 kg-cm / [30.4~34.7 lb-in.] / [3.4~3.9 Nm]
3. For 9~11 shown in the figure 2: Loosen the screws and removes the cover. Screw M4 torque: 14~16 kg-cm / [12.2~13.9 lb-in.] / [1.4~1.6 Nm]

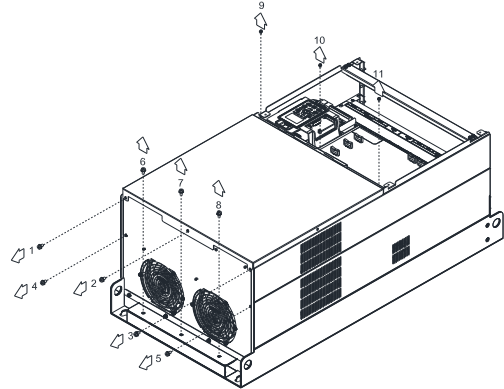

Figure 2

4. Loosen screw 1, 2, 3 and remove the protective ring (as shown in figure 3) Screw torque: 14~16 kg-cm / [12.2~13.9 lb-in.] / [1.4~1.6 Nm]

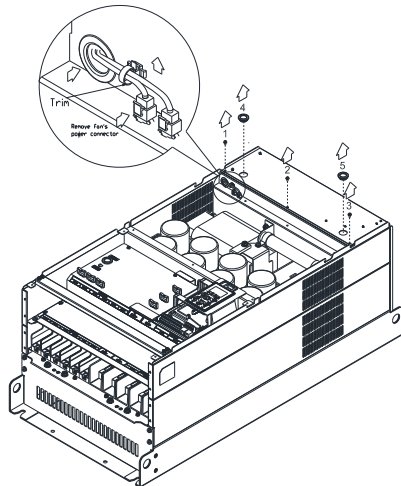

Figure 3

5. Lift the fan by putting your finger through the protective holes, as indicates in 1 and 2 on the figure 4.

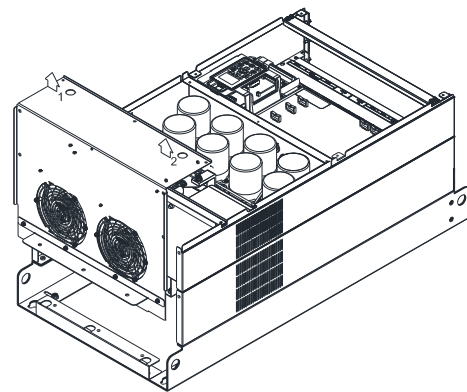

Figure 4

6. For old drivers switching new fans, please follow below steps:  
Loosen screws 1~5, remove the cover (as below figure shown) M4 screw torque: 14~16 kg-cm / [12.2~13.9 lb-in.] / [1.4~1.6 Nm]

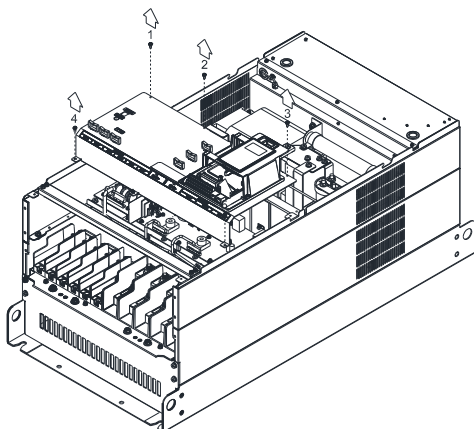

Figure 5

7. Add cable model 3864483201 to connect the power board and fan connector. (The cable 3864483201 goes with the fan as accessory)

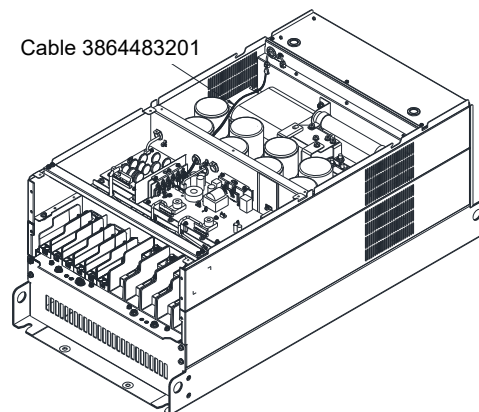

Figure 6

**Frame H**

Applicable model

VFD2800C43A/43E; VFD3150C43A/43E; VFD3550C43A/43E; VD4500C43A/43E; VFD2800C43E-1; VFD3150C43E-1; VFD3550C43E-1; VFD4500C43E-1

**Fan model "MKC-HFKM" Heat Sink Fan**

1. Loosen the screw 1~4 and remove the top cover (figure 1)  
Screw torque: 14~16 kg-cm / [12.2~13.9 lb-in.] / [1.4~1.6 Nm]

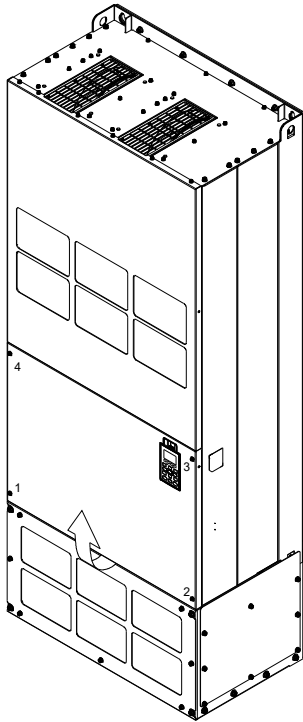

Figure 1

2. Loosen the screw 5~12 and remove the top cover (figure 2). Screw torque: 24~26kg-cm / [20.8~22.6 lb-in.] / [2.4~2.5 Nm]

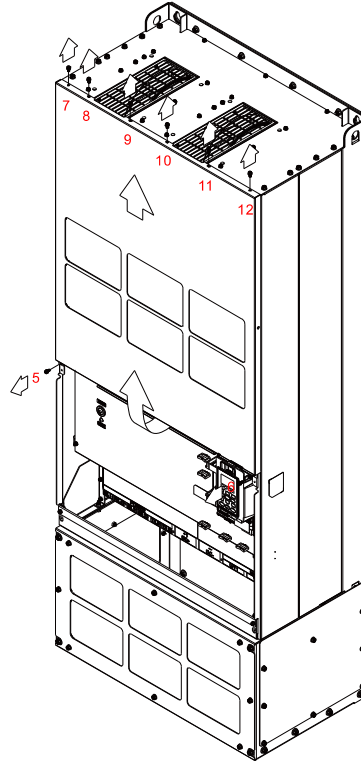

Figure 2

3. Press the latch to disconnect fan power (figure 3).

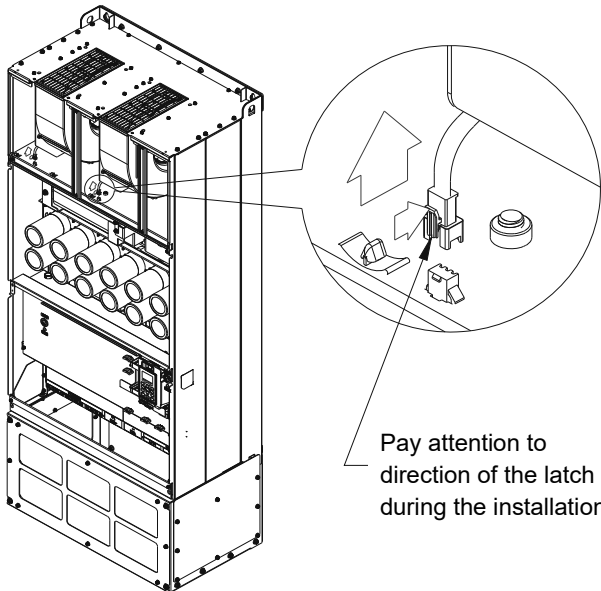

Figure 3

4. Loosen the screw 13~18 and remove the fan. Screw torque: 24~26kg-cm / [20.8~22.6 lb-in.] / [2.4~2.5 Nm] (figure 4)

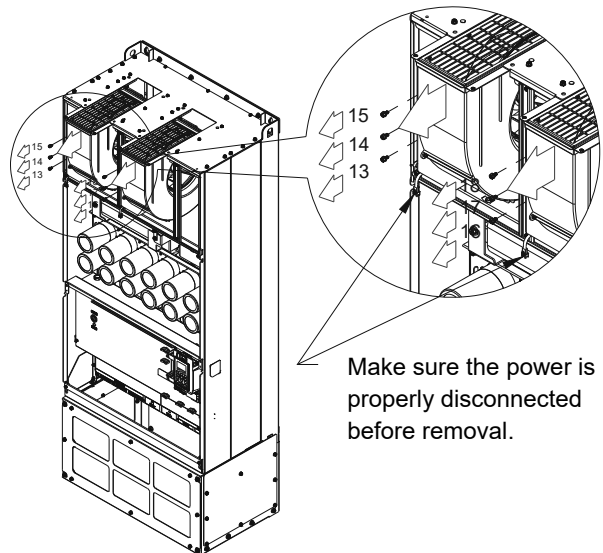

Figure 4

Frame H

Applicable model

VFD4000C63B-00; VFD4000C63B-21

Fan model "MKC-HFKM1" Heat Sink Fan

1. Loosen the screw 1~4 and remove the top cover (figure 1)  
Screw torque: 14~16 kg-cm / [12.2~13.9 lb-in.] / [1.4~1.6 Nm]

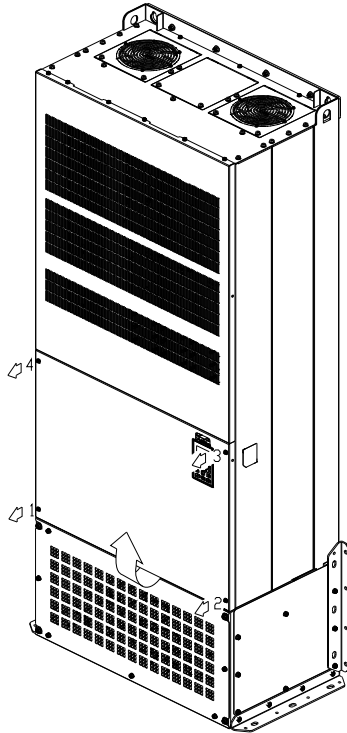

Figure 1

2. Loosen the screw 1~8 and remove the top cover (figure 2).  
Screw torque: 24~26kg-cm / [20.8~22.6 lb-in.] / [2.4~2.5 Nm]

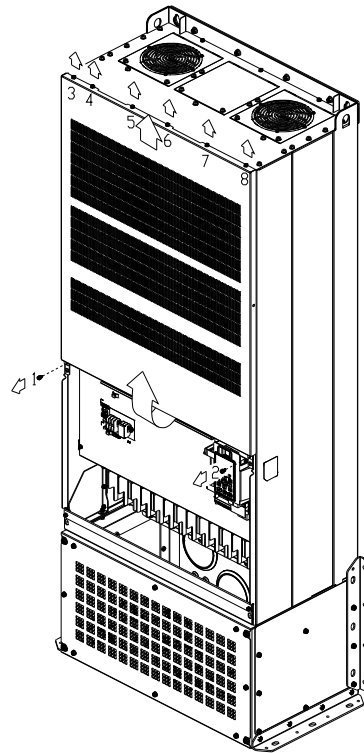

Figure 2

3. Disconnect the fan connector (figure 3).

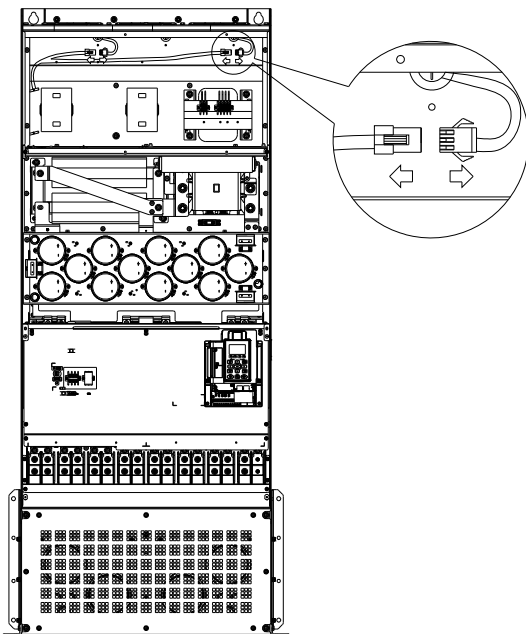

Figure 3

4. Loosen screws 1~4 (as shown below) and remove the fan. Make sure the fan is disconnected when removing. Screw torque: 24~26kg-cm / [20.8~22.6 lb-in.] / [2.4~2.5 Nm] (figure 4)

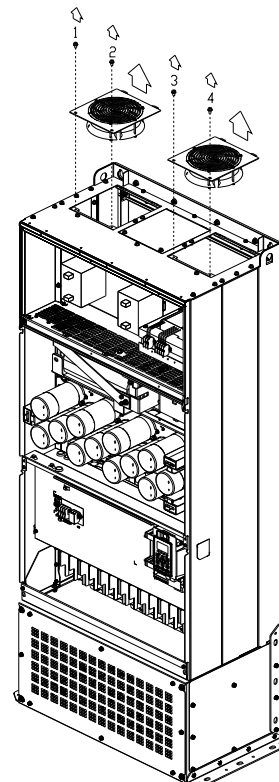

Figure 4

Frame H

Applicable model

VFD4500C63B-00; VFD5600C63B-00; VFD6300C63B-00; VFD4500C63B-21; VFD5600C63B-21; VFD6300C63B-21

Fan model "MKC-HFKM1" Heat Sink Fan

1. Loosen the screw 1~4 and remove the top cover (figure 1)  
Screw torque: 14~16 kg-cm / [12.2~13.9 lb-in.] / [1.4~1.6 Nm]

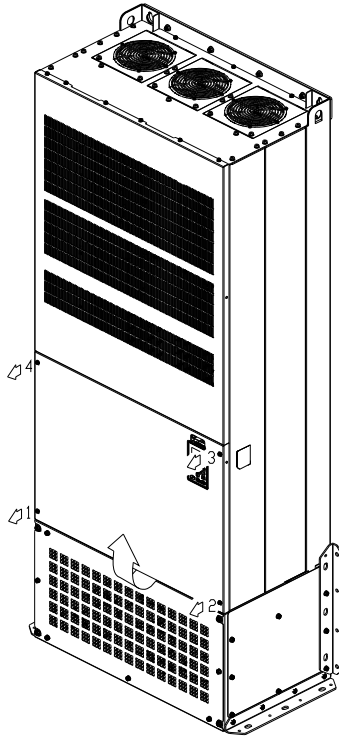

Figure 1

2. Loosen the screw 1~8 and remove the top cover (figure 2).  
Screw torque: 24~26kg-cm / [20.8~22.6 lb-in.] / [2.4~2.5 Nm]

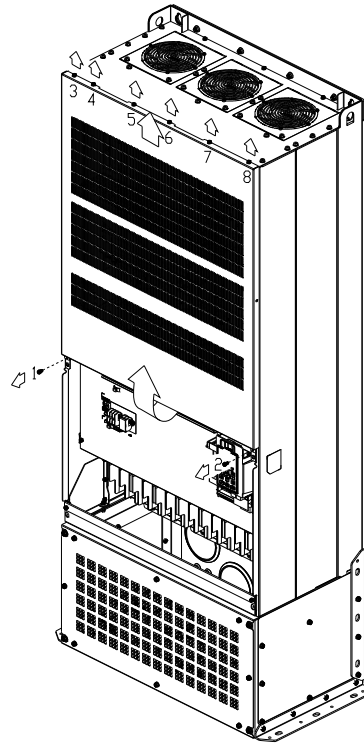

Figure 2

3. Disconnect the fan connector (figure 3).

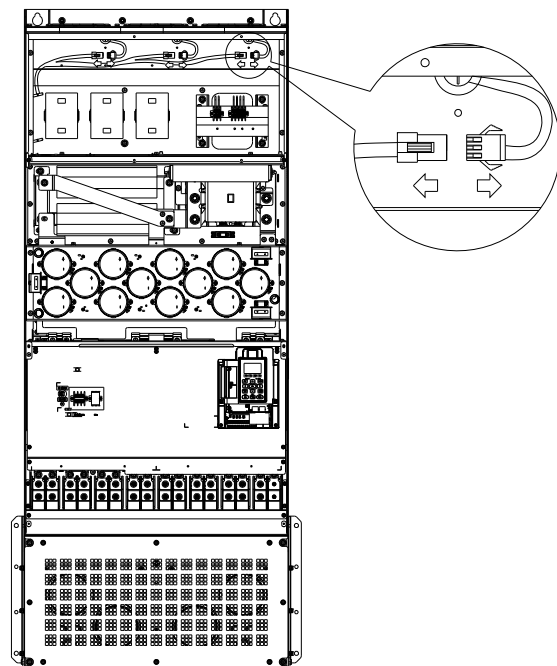

Figure 3

4. Loosen screws 1~6 (as shown below) and remove the fan. Make sure the fan is disconnected when removing. Screw torque: 24~26kg-cm / [20.8~22.6 lb-in.] / [2.4~2.5 Nm] (figure 4)

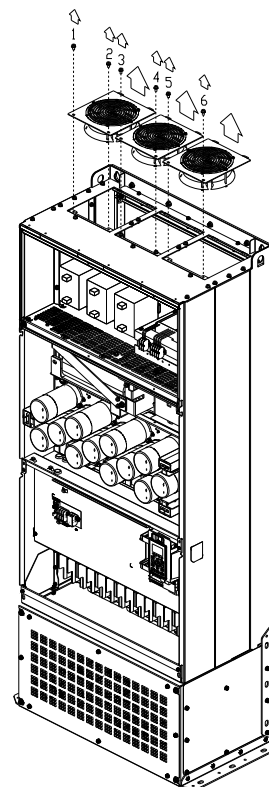

Figure 4

## 7-10 Flange Mounting Kit

Applicable Models, Frame A~F  
 Frame A

『MKC-AFM1』

Applicable model

VFD015C23A; VFD022C23A; VFD022C43A/43E; VFD015C53A-21; VFD022C53A-21; VFD037C53A-21

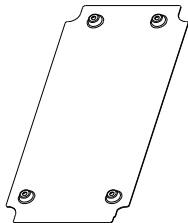

Accessories 1\*1

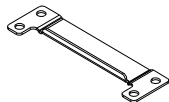

Accessories 2\*2

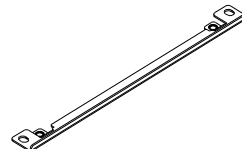

Accessories 3\*2

Screw 1 \*4  
 M3\*P 0.5; L=6mm

Screw 2\*8  
 M6\*P 1.0; L=16mm

『MKC-AFM』

Applicable model

VFD007C23A; VFD007C43A/43E; VFD015C43A/43E; VFD037C23A; VFD037C43A/43E; VFD040C43A/43E;  
 VFD055C43A/43E

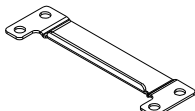

Accessory 2\*2

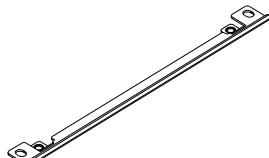

Accessory t 3\*2

Screw \*8  
 M6\*P 1.0; L=16mm

Cutout dimension

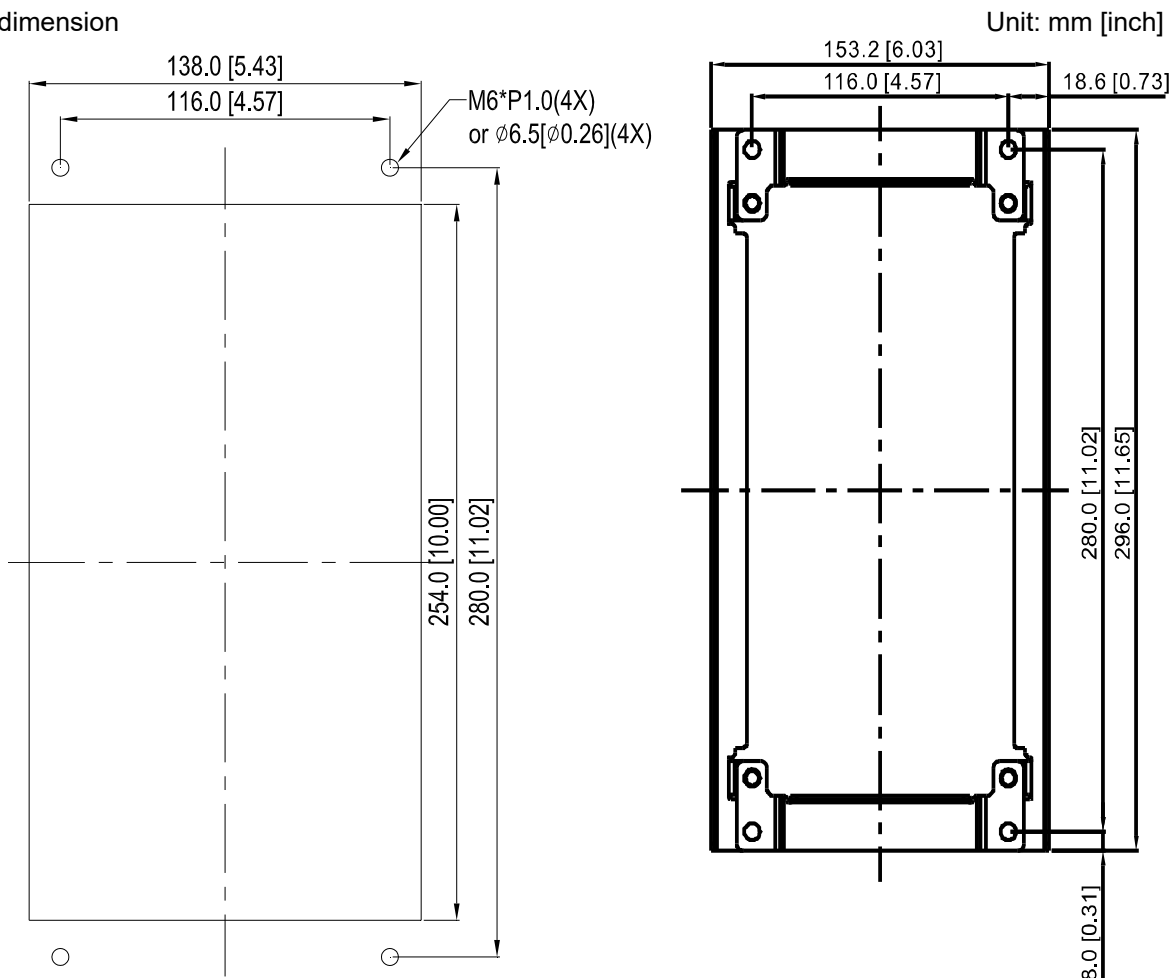



『MKC-AFM1』 Installation

1. Install accessory 1 by fastening 4 of the screw 1 (M3) (figure 1). Screw torque: 6~8 kg-cm / [5.21~6.94 lb-in.] / [0.6~0.8 Nm]

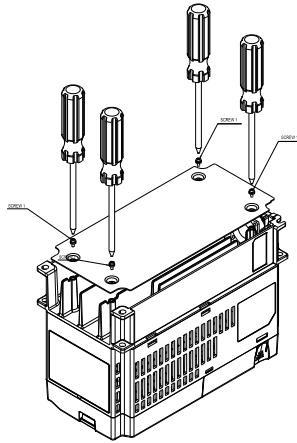

Figure 1

2. Install accessory 2&3 by fastening 2 of the screw 2 (M6) (figure 2). Screw torque: 25~30 kg-cm / [21.7~26 lb-in.] / [2.5~2.9 Nm]

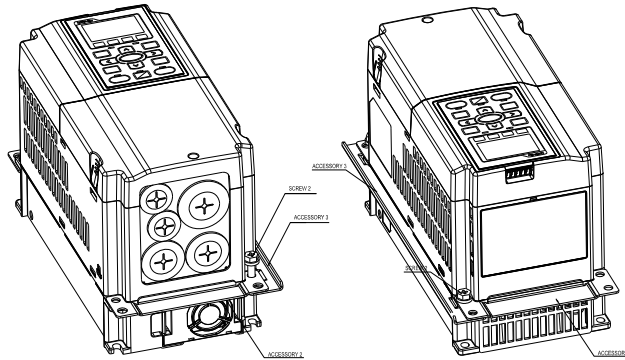

Figure 2

3. Install accessory 2 & 3 by fastening 2 of the screw 2 (M6) (figure 3). Screw torque: 25~30 kg-cm / [21.7~26 lb-in.] / [2.5~2.9 Nm]

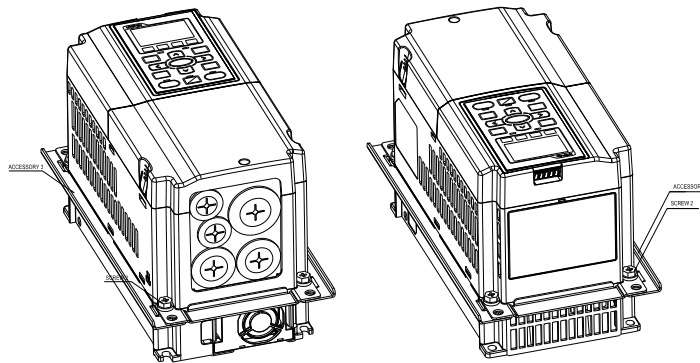

Figure 3

4. Plate installation, place 4 of the screw 2 (M6) (figure 4) through accessory 2 & 3 and the plate then fasten the screws. Screw torque: 25~30 kg-cm / [21.7~26 lb-in.] / [2.5~2.9 Nm]

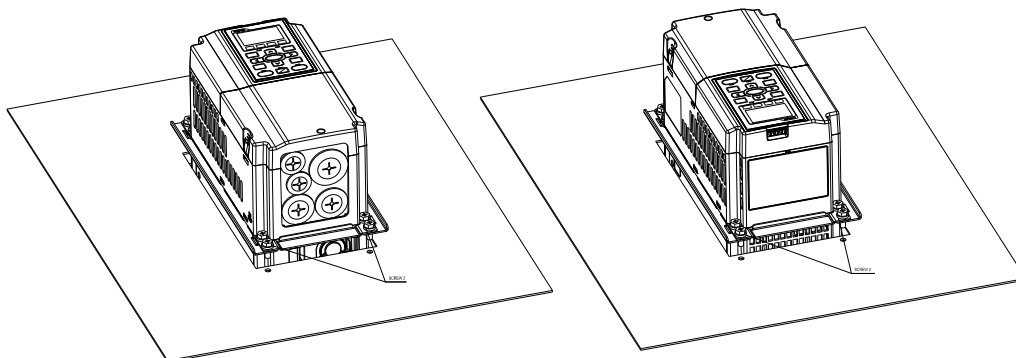

Figure 4

『MKC-AFM』 Installation

1. Fasten screw\*2 (M6) and accessory 2 & 3. Screw torque: 25~30 kg-cm / [21.7~26 lb-in.] / [2.5~2.9 Nm] (figure 1)

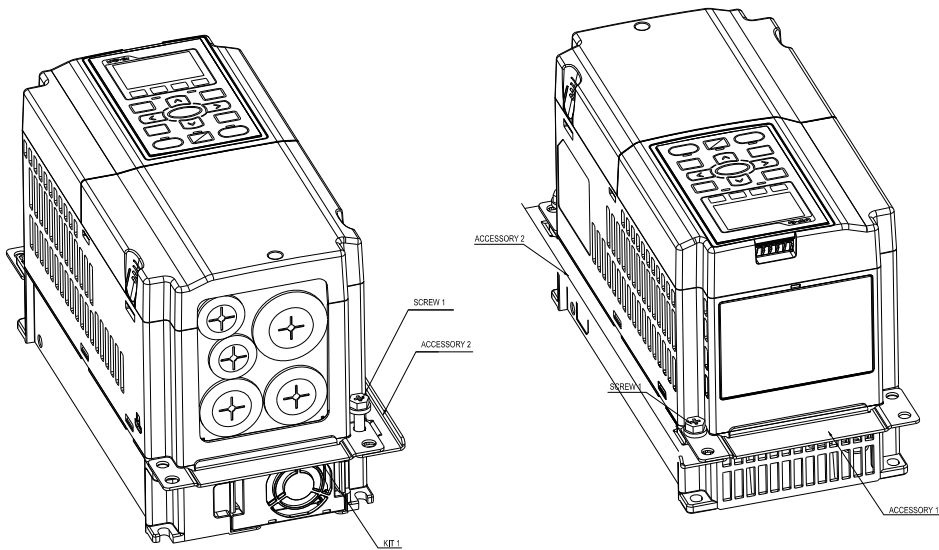

Figure 1

2. Fasten screw\*2 (M6) and accessory 2 & 3. Screw torque: 25~30 kg-cm / [21.7~26 lb-in.] / [2.5~2.9 Nm] (figure 2)

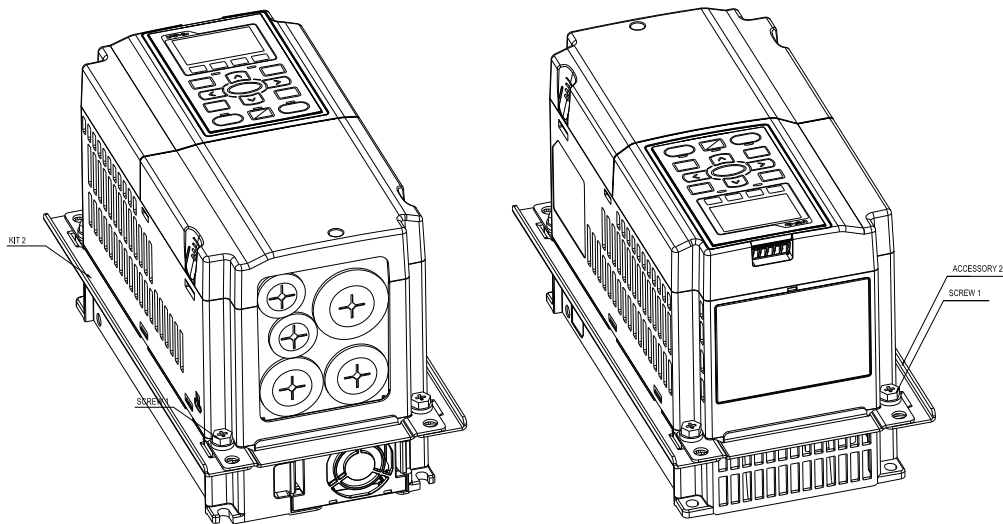

Figure 2

3. Plate installation, place 4 of the screw \*4 (M6) through accessory 2 & 3 and the plate then fasten the screws. Screw torque: 25~30 kg-cm / [21.7~26 lb-in.] / [2.5~2.9 Nm] (figure 3)

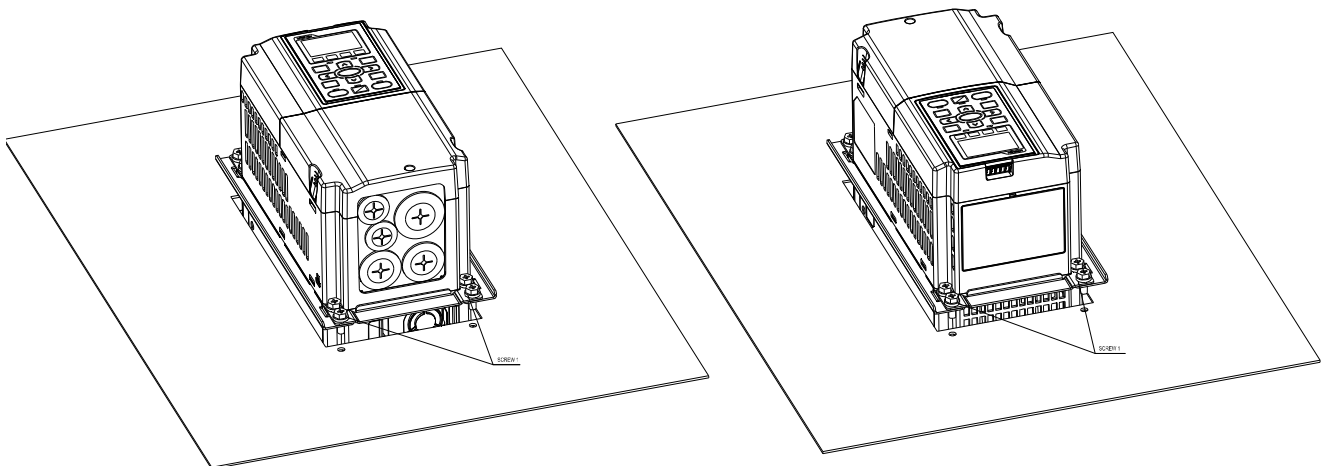

Figure 3

Frame B

『MKC-BFM』

Applicable model

VFD055C23A; VFD075C23A; VFD110C23A; VFD075C43A/43E; VFD110C43A/43E; VFD150C43A/43E; VFD055C53A-21;  
 VFD075C53A-21; VFD110C53A-21; VFD150C53A-21

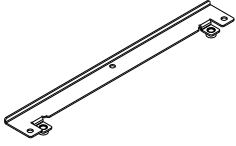

Accessory 1\*2

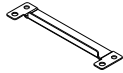

Accessory 2\*2

Screw 1 \*4 ~ M8\*P 1.25;  
 Screw 2\*6 ~ M6\*P 1.0

Cutout dimension

Unit: mm [inch]

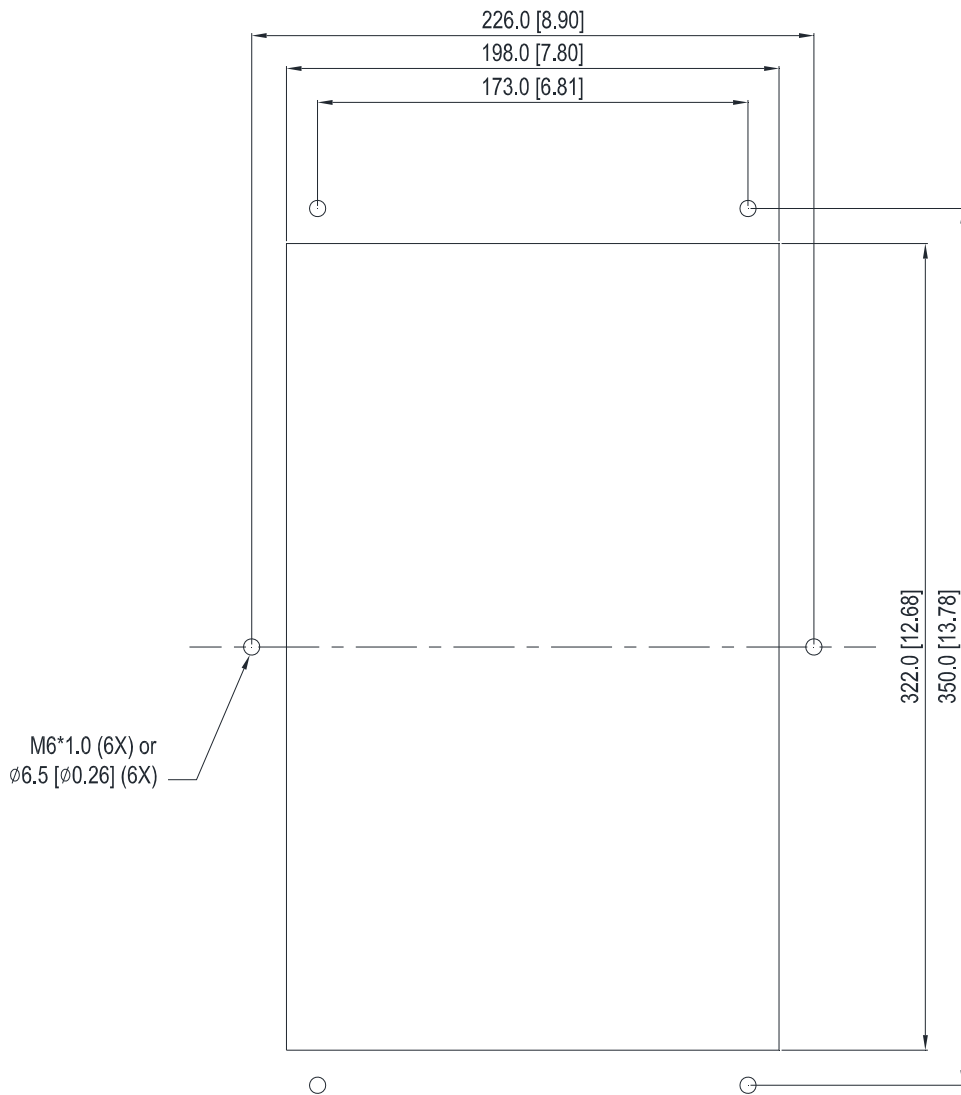

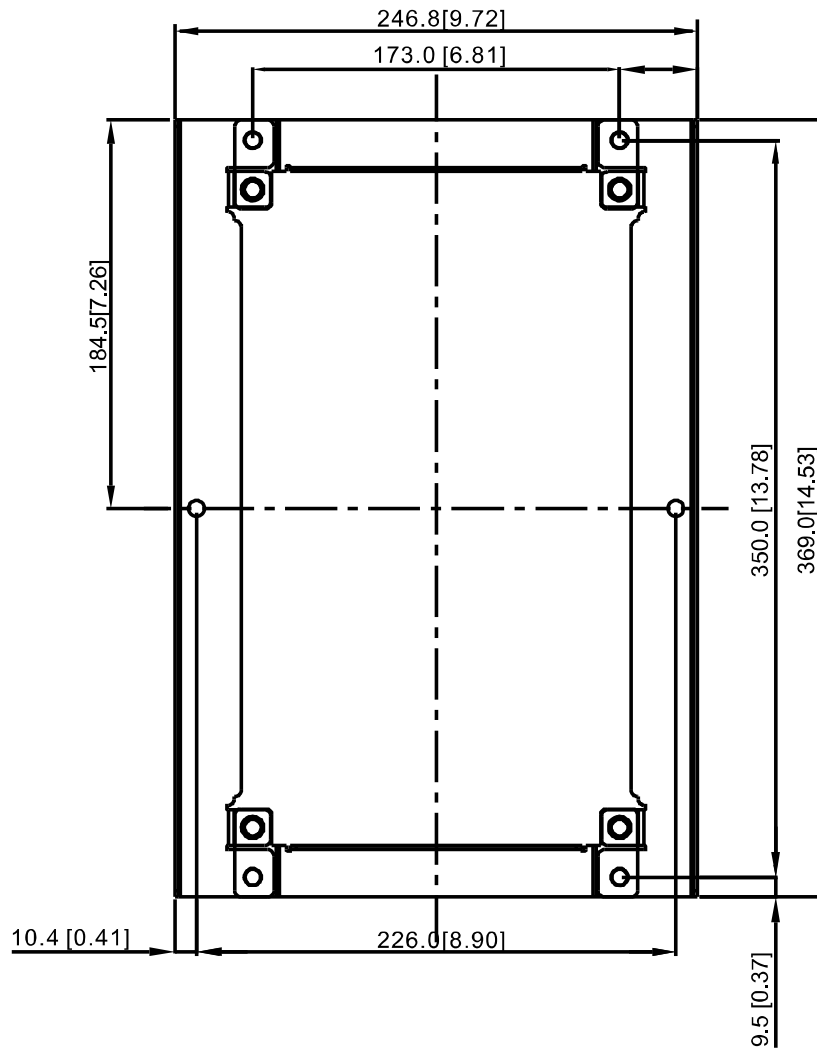

『MKC-BFM』 Installation

1. Install accessory 1 & 2 by fastening 4 of the screw 1 (M8). Screw torque: 40~45 kg-cm / [34.7~39.0 lb-in.] / [3.9~4.4 Nm] (As shown in the following figure)

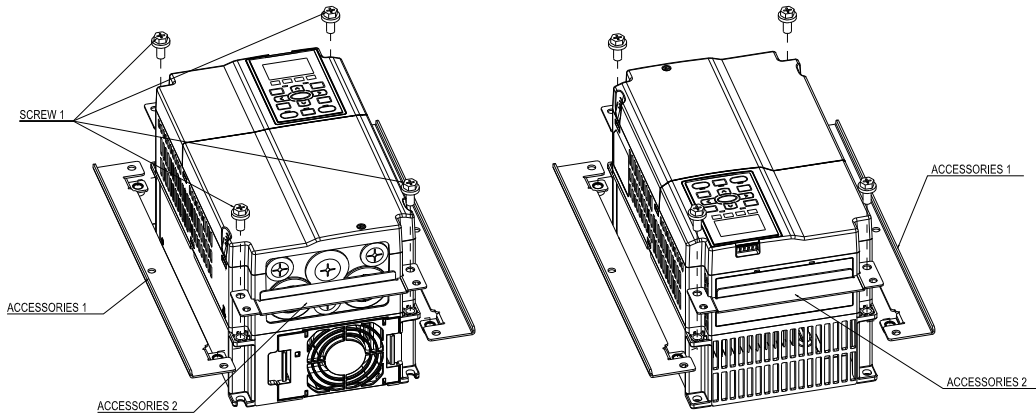

2. Plate installation, place 6 of the screw 2 (M6) through accessory 1 & 2 and the plate then fasten the screws. Screw torque: 25~30 kg-cm / [21.7~26 lb-in.] / [2.5~2.9 Nm] (As shown in the following figure)

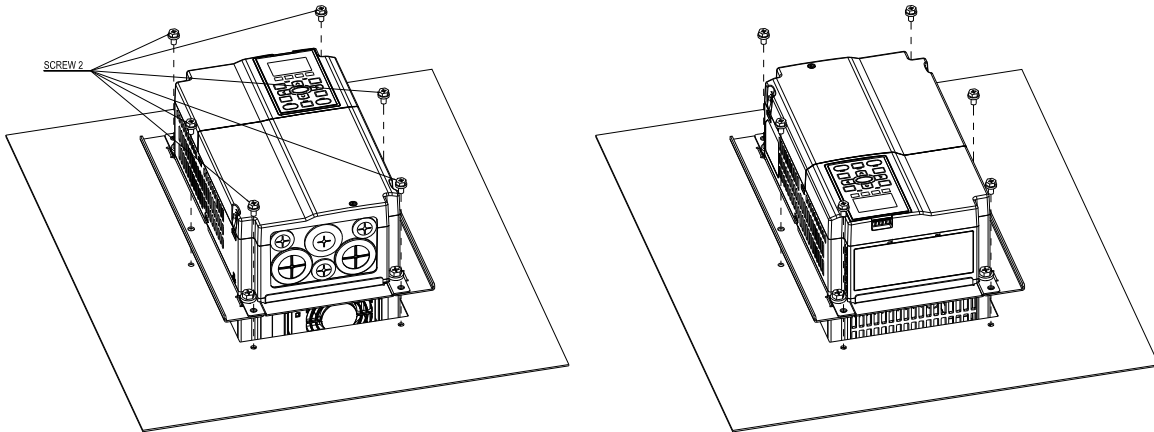

Frame C

『MKC-CFM』

Applicable model

VFD150C23A; VFD185C23A; VFD220C23A; VFD185C43A/43E; VFD220C43A/43E; VFD300C43A/43E; VFD185C63B-21;  
 VFD220C63B-21; VFD300C63B-21; VFD370C63B-21

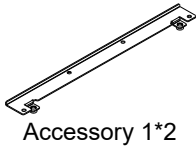

Screw 1\*4 ~ M8\*P 1.25;  
 Screw 2\*8 ~ M6\*P 1.0

Cutout dimension

Unit: mm [inch]

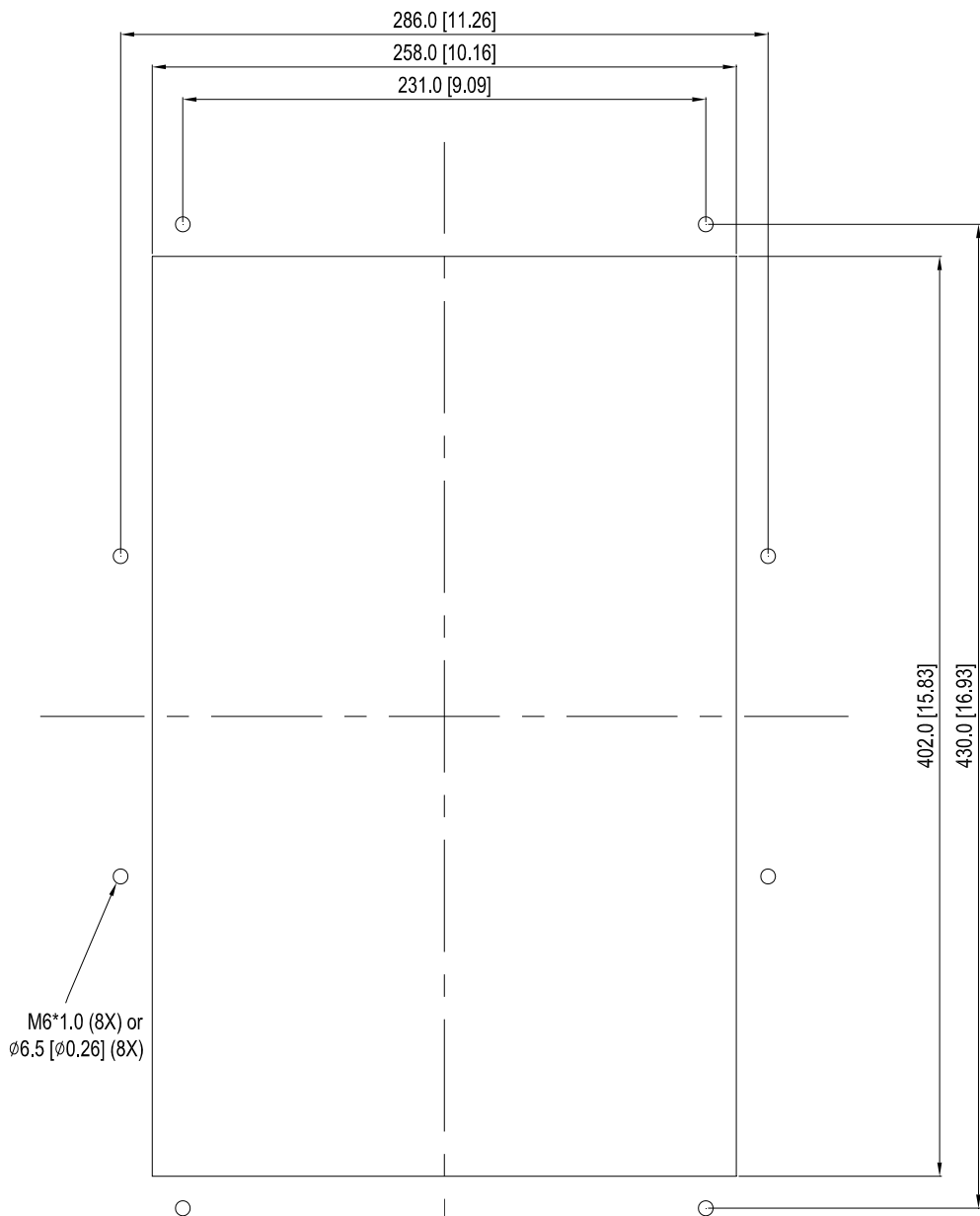

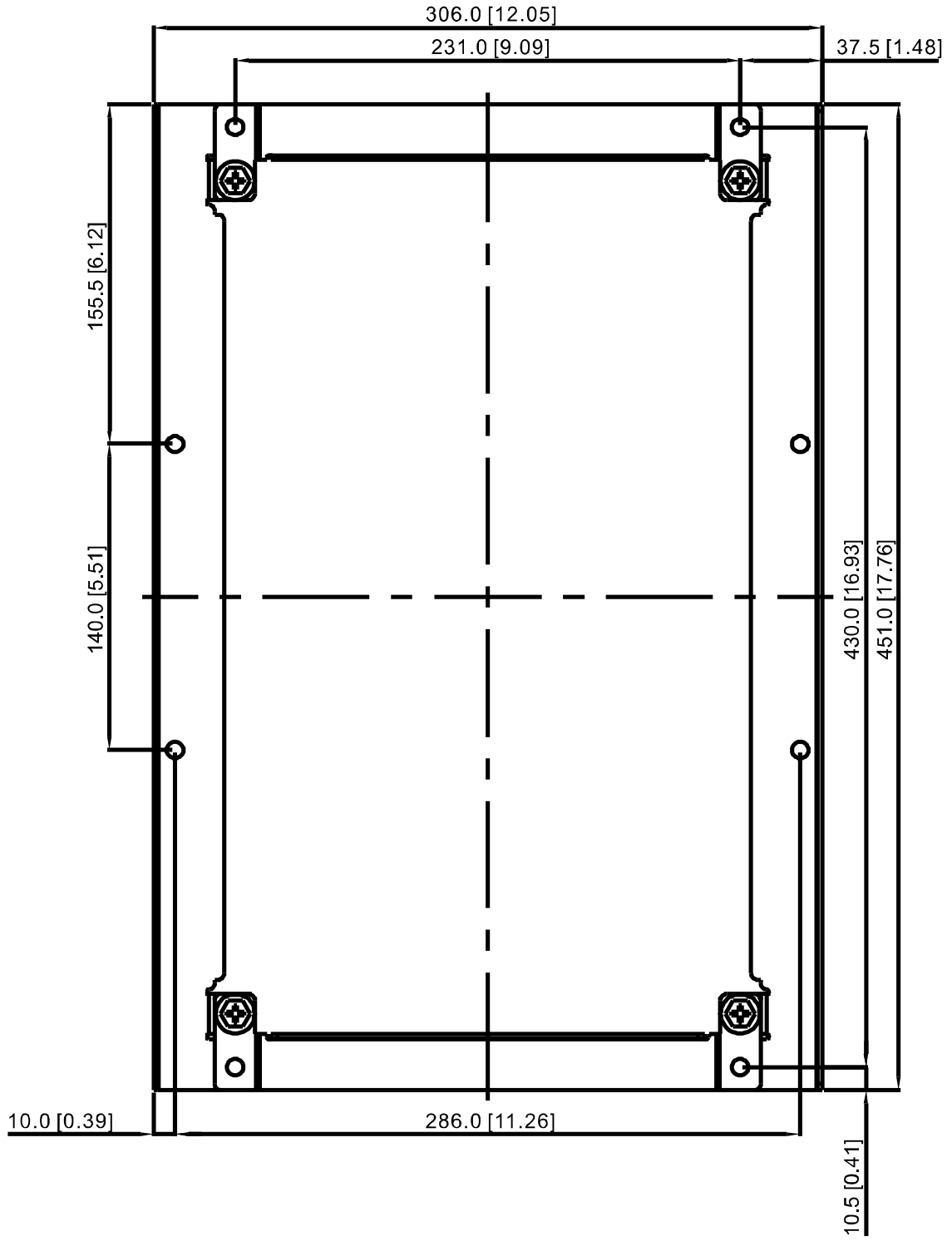

## 『MKC-CFM』 Installation

1. Install accessory 1 & 2 by fastening 4 of the screw 1 (M8). Screw torque: 50~55 kg-cm / [43.4~47.7 lb-in.] / [4.9~5.4 Nm] (As shown in the following figure)

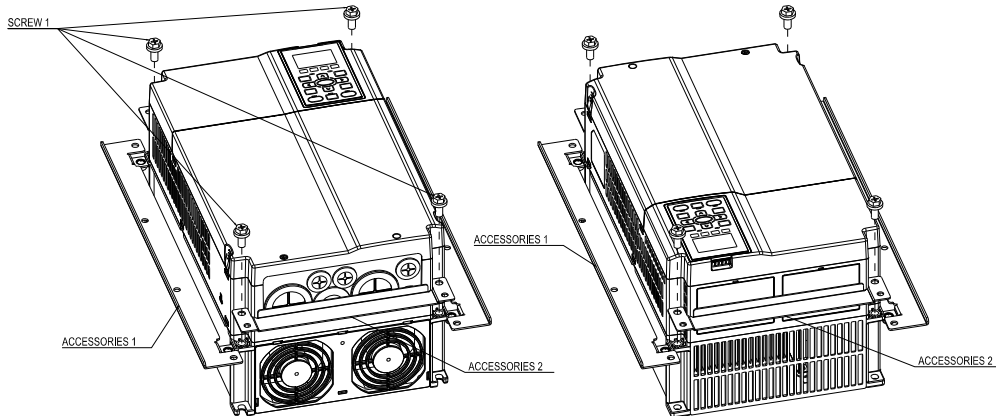

2. Plate installation, place 8 of the screw 2 (M6) through Accessory 1 & 2 and the plate then fasten the screws. Screw torque: 25~30 kg-cm / [21.7~26 lb-in.] / [2.5~2.9 Nm] (As shown in the following figure)

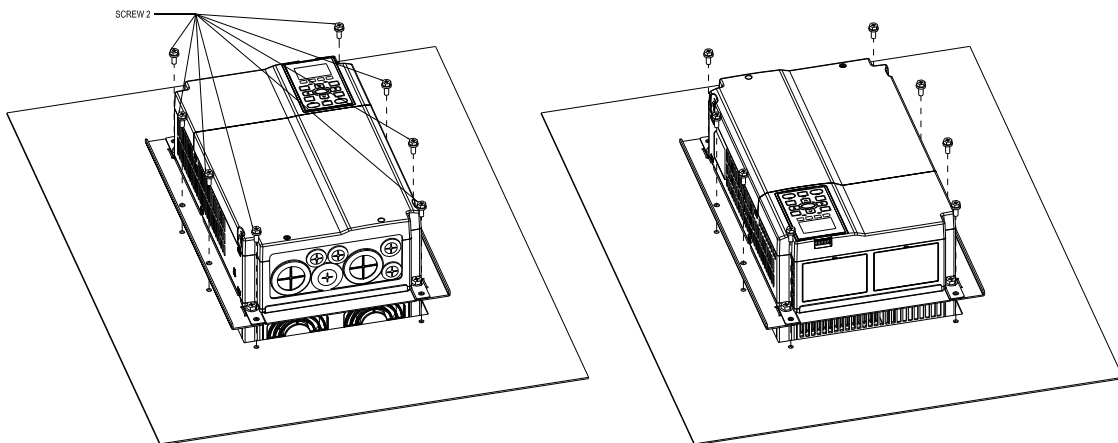



### Frame D0

Applicable model

VFD370C43S/U; VFD450C43S/U

Cutout dimension

Unit: mm [inch]

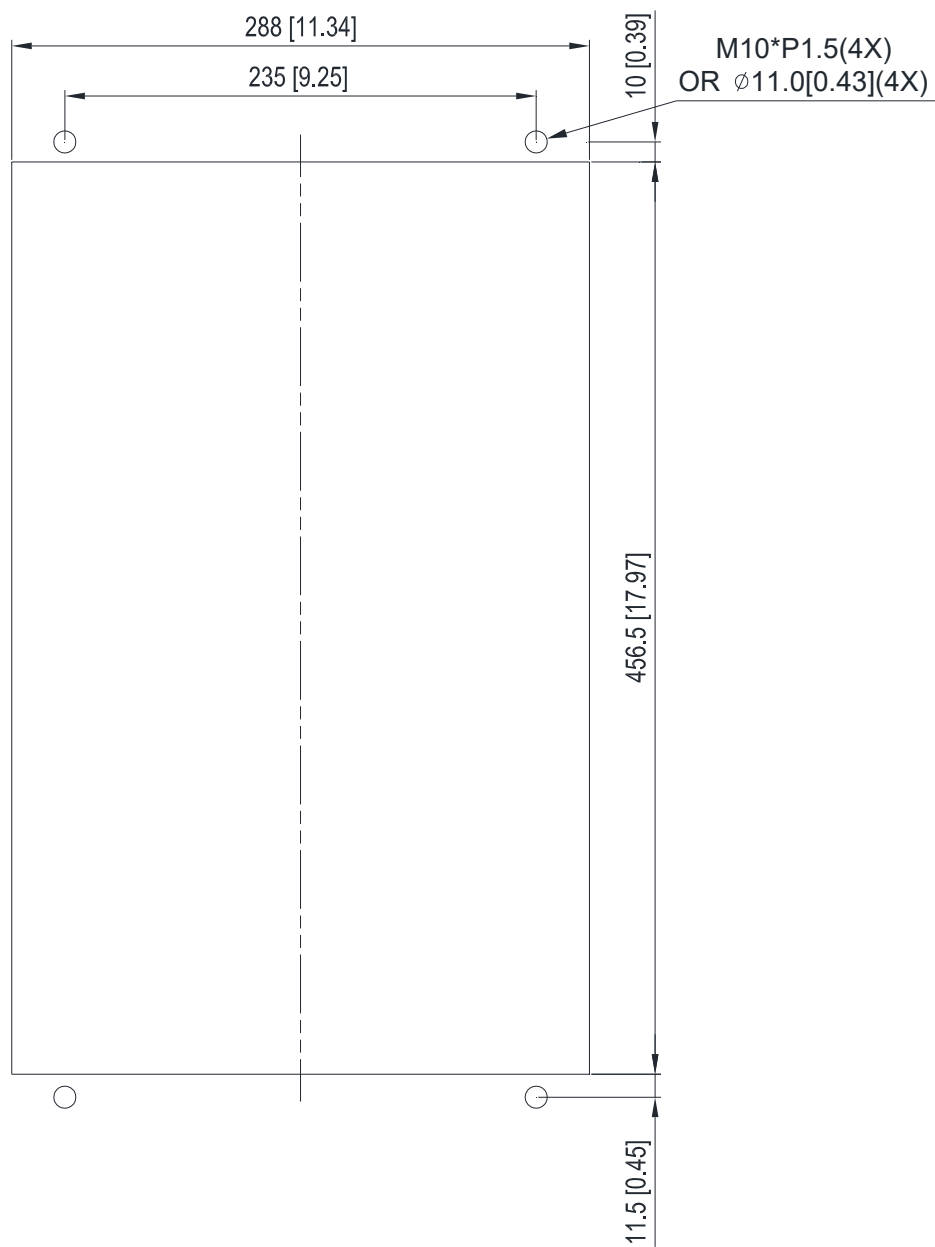

## Frame D

## Applicable model

VFD300C23A/23E; VFD370C23A/23E; VFD550C43A/43E; VFD750C43A/43E; VFD450C63B-00; VFD550C63B-00;  
VFD450C63B-21; VFD550C63B-21

## Cutout dimension

Unit: mm [inch]

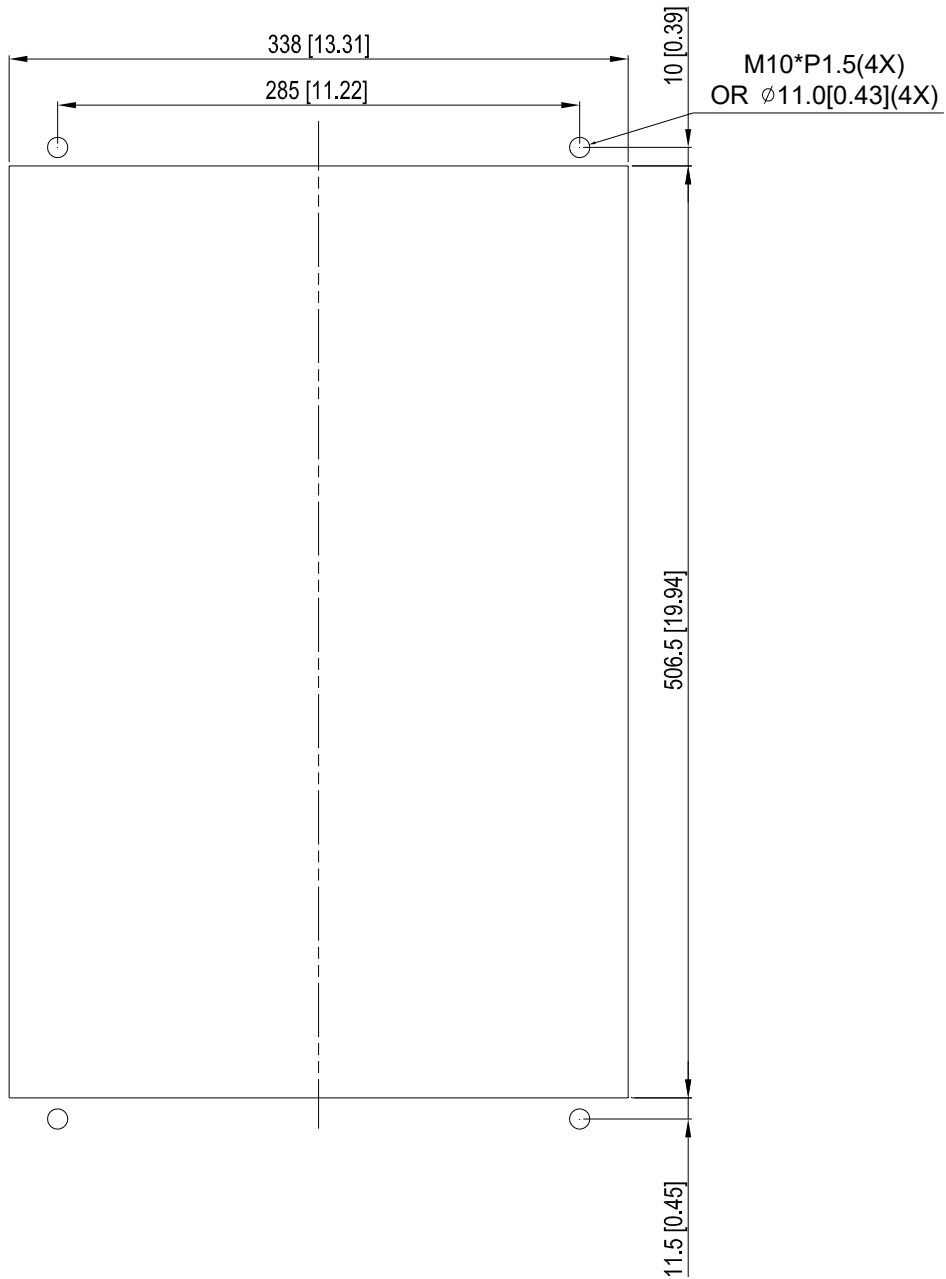

### Frame E

Applicable model

VFD450C23A/23E; VFD550C23A/23E; VFD750C23A/23E; VFD900C43A/43E; VFD1100C43A/43E; VFD750C63B-00;  
VFD900C63B-00; VFD1100C63B-00; VFD1320C63B-00; VFD750C63B-21; VFD900C63B-21; VFD1100C63B-21;  
VFD1320C63B-21

Cutout dimension

Unit: mm [inch]

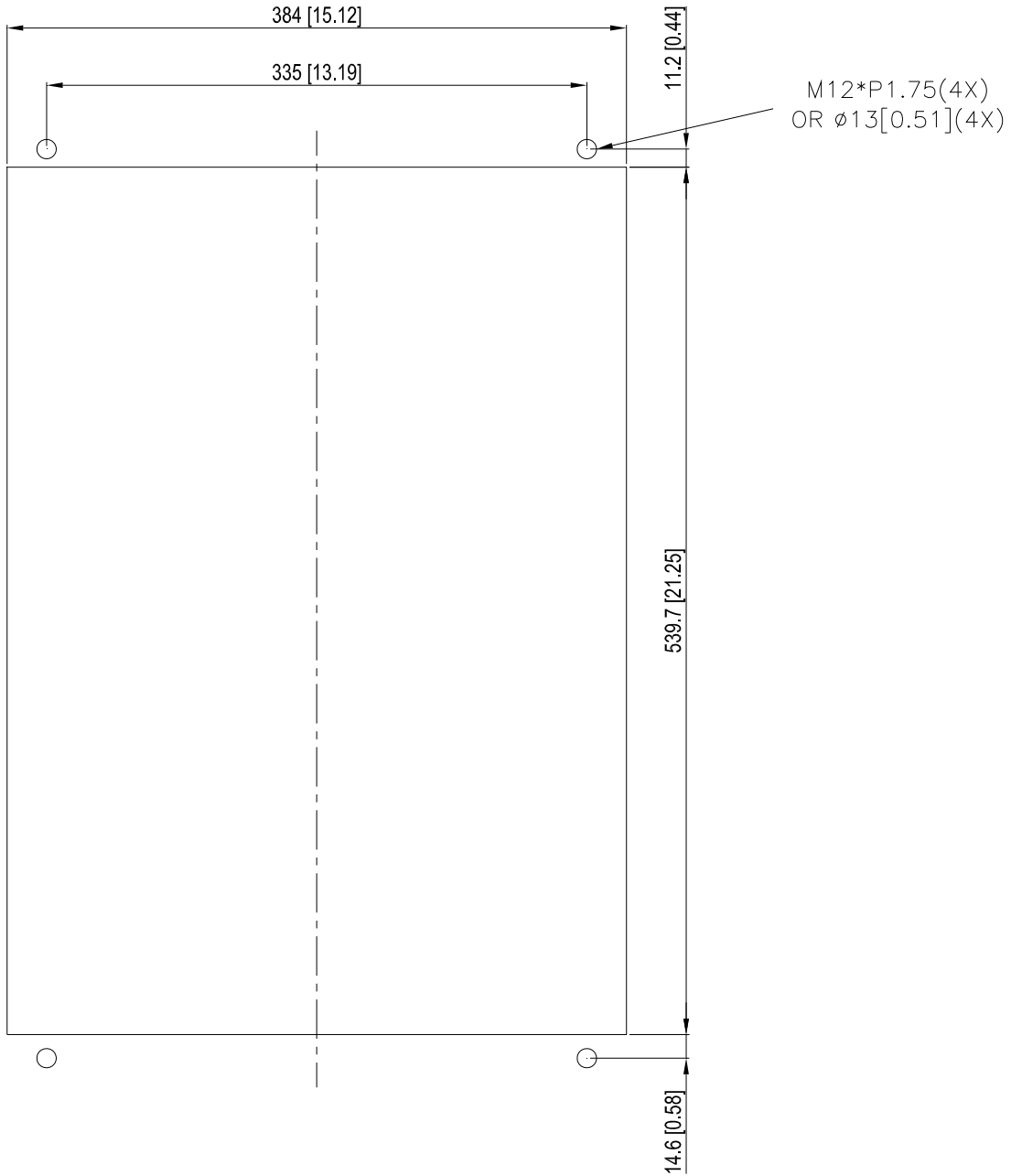

Frame D0 & D & E

1. Loosen 8 screws and remove Fixture 2 (as shown in the following figure).

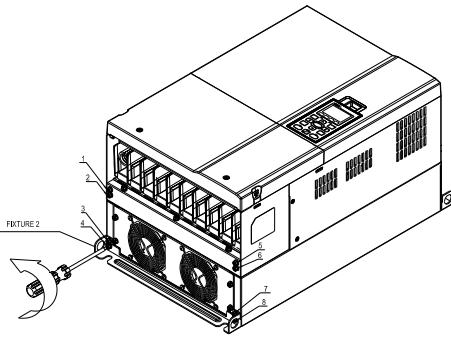

2. Loosen 10 screws and remove Fixture 1 (as shown in the following figure).

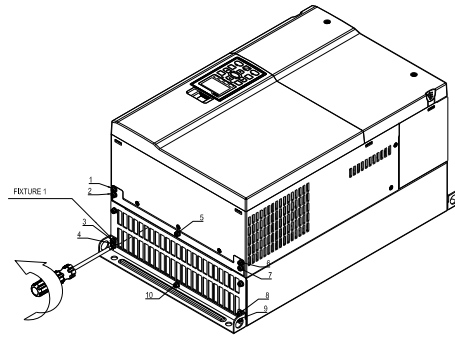

3. Fasten 4 screws (as shown in the following figure).  
Screw torque: 30~32 kg-cm / [26.0~27.8 lb-in.] / [2.9~3.1 Nm].

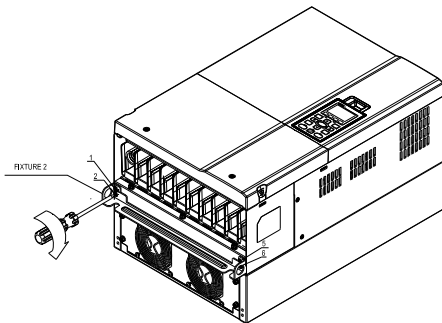

4. Fasten 5 screws (as shown in the following figure).  
Screw torque: 30~32 kg-cm / [26.0~27.8 lb-in.] / [2.9~3.1 Nm]

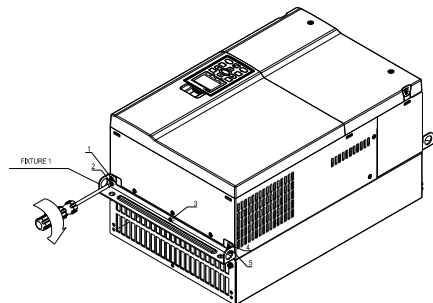

5. Fasten 4 screws (as shown in the following figure).  
Screw torque: 24~26 kg-cm / [20.8~22.6 lb-in.] / [2.4~2.5 Nm]

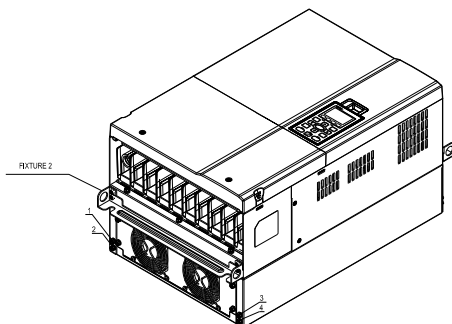

6. Fasten 5 screws (as shown in the following figure).  
Screw torque: 24~26 kg-cm / [20.8~22.6 lb-in.] / [2.4~2.5 Nm]

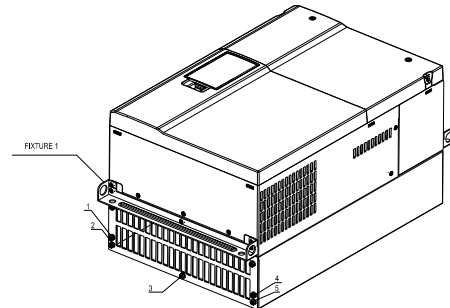

7. Place 4 screws (M10) through Fixture 1 & 2 and the plate then fasten the screws. (as shown in the following figure)

Frame D0/D M10\*4

Screw torque: 200~240 kg-cm / [173.6~208.3 lb-in.] / [19.6~235 Nm]

Frame E M12\*4

Screw torque: 300~400 kg-cm / [260~347 lb-in.] / [29.4~39.2 Nm]

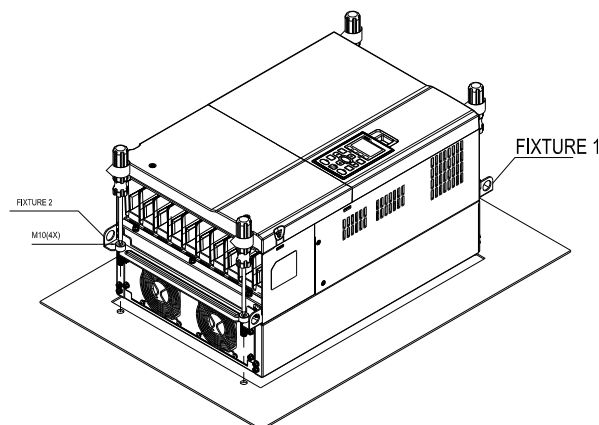

Frame F

Applicable model

VFD900C23A/23E; VFD1320C43A/43E; VFD1600C43A/43E; VFD1600C63B-00; VFD2000C63B-00;  
VFD1600C63B-21; VFD2000C63B-21

Cutout dimension

Unit: mm [inch]

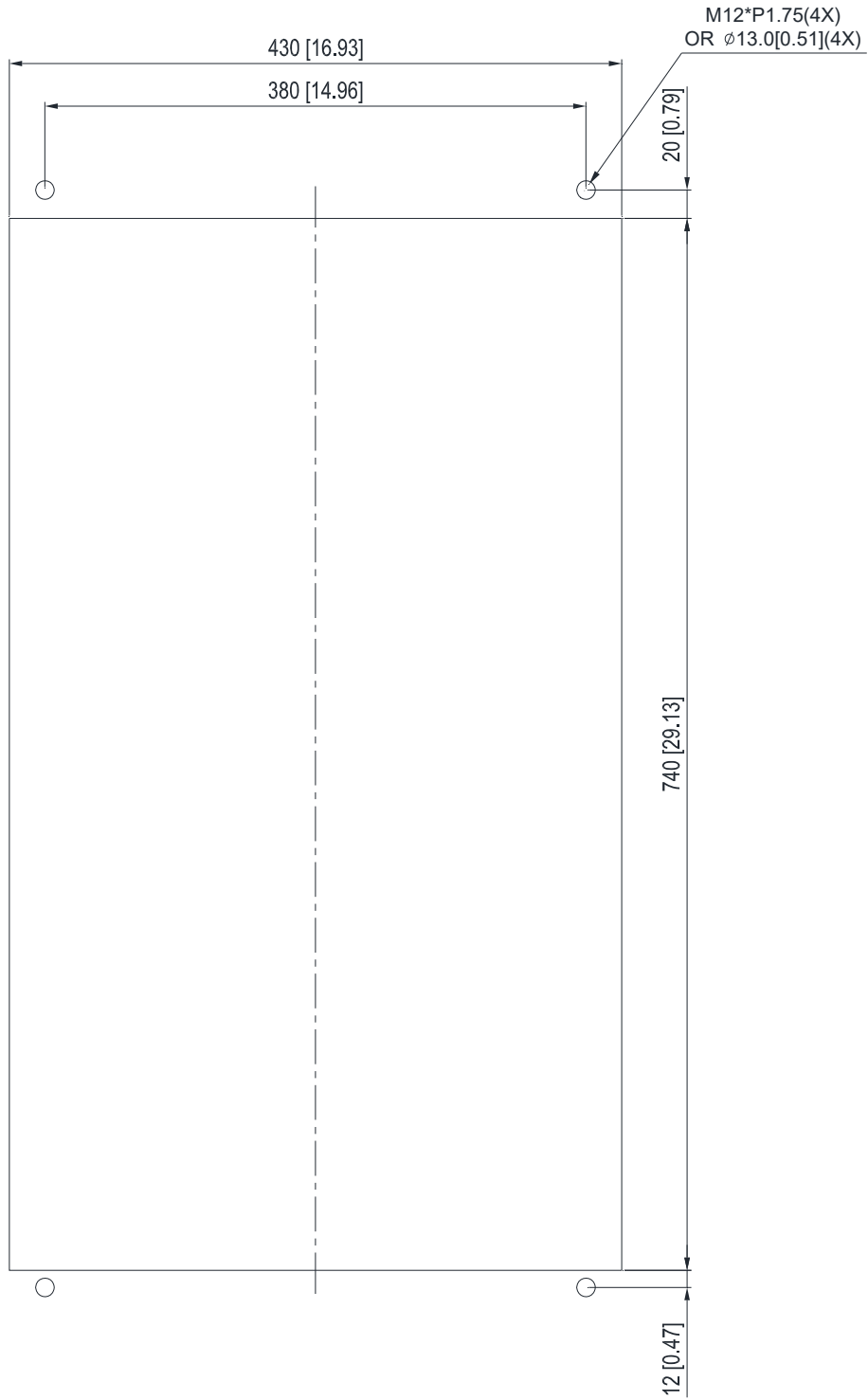

Frame F

1. Loosen 12 screws and remove Fixture 2.

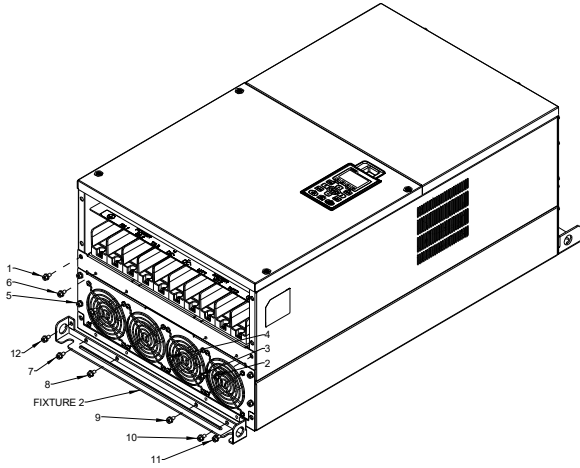

2. Loosen 12 screws and remove Fixture 2.  
Screw torque: 24~26 kg-cm / [20.8~22.6 lb-in.] / [2.4~2.5 Nm]

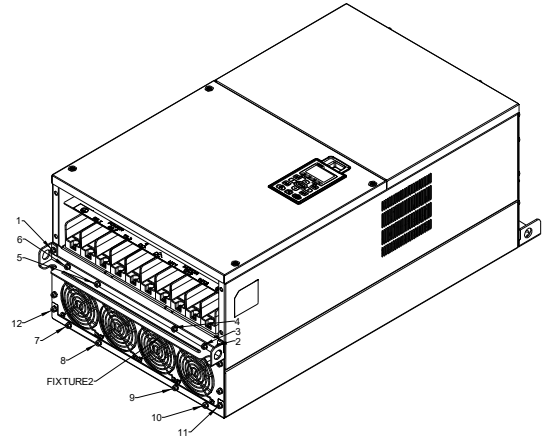

3. Loosen screw 13 ~26 and remove Fixture 1.

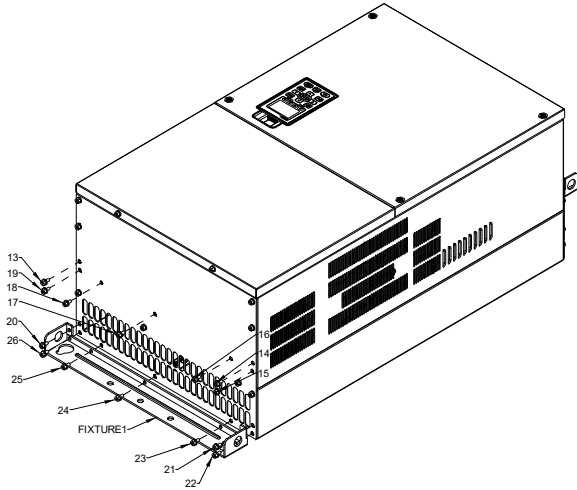

4. Install Fixture 1 by fasten screw 13 ~26  
Screw torque: 24~26 kg-cm / [20.8~22.6 lb-in.] / [2.4~2.5 Nm]

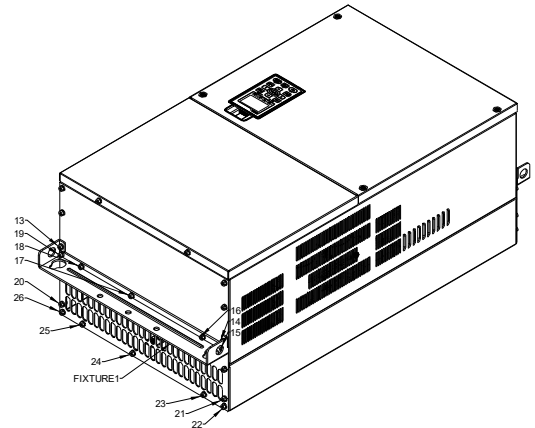

5. Place 4 of the M12 screws through Fixture 1&2 and plate then fasten the screws.  
Screw torque: 300~400 kg-cm / [260~347 lb-in.] / [29.4~39.2 Nm]

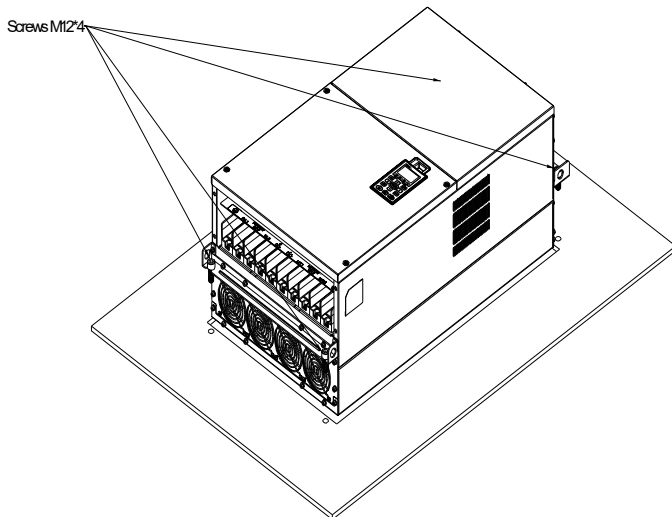

## 7-11 Power Terminal Kit

『MKC-PTCG』 (Applicable for Frame G models-VFDXXXCXXA)

Applicable model

VFD1850C43A; VFD2200C43A

(The MKC-PTCG is optional for the above models, after installation, the 12 plus will be 6 plus.)

### Accessories

Item	Description	Q'ty
1	Copper Assy.	3
1.1	Copper	3
1.2	Screw M12*25L	6
1.3	Spring	6
1.4	Washer	6
1.5	Nuts	6

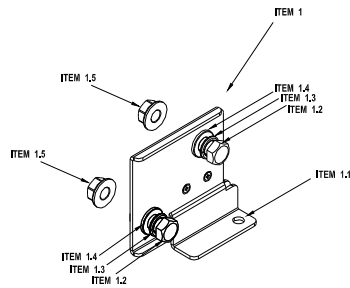
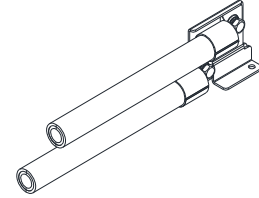
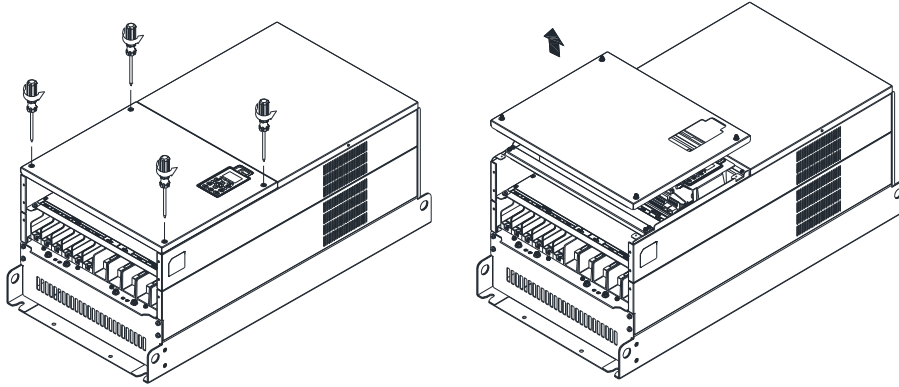

Diagram of power terminal connection  
M12 Torque: 408 kg-cm / [354.1 lb-in] / [39.98 Nm]



### 『MKC-PTCG』 Installation

- Loosen the 4 screws on the cover, as shown in the following figure. Screw Torque: 12~15 kg-cm / [10.4~13 lb-in] / [1.2~1.5 Nm]



- Remove the 5 screws from the FR4 board, as shown in the following figure. (The FR4 board is not needed after the installation of the power terminal kit). Screw Torque: 12~15 kg-cm / [10.4~13 lb-in] / [1.2~1.5 Nm]

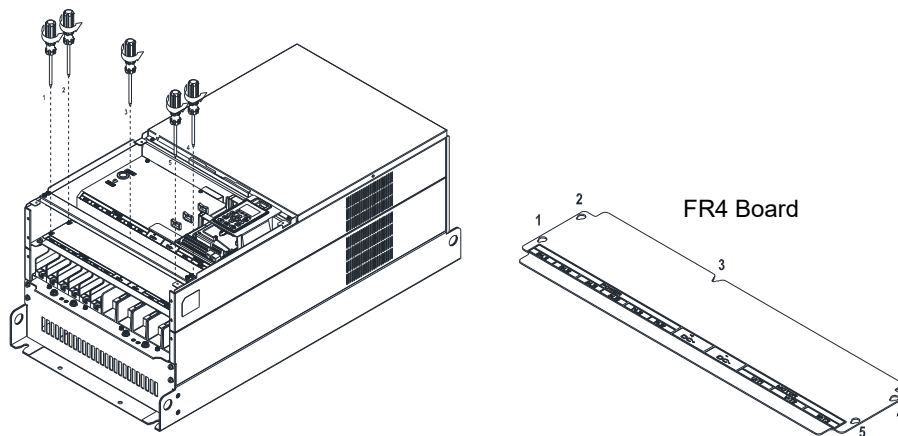

3. Loosen the upper M8 nuts (1~6) with a sleeve wrench (12mm of the sleeve). M8 Torque: 90kg / [78.1 lb-in] / [8.8 Nm]

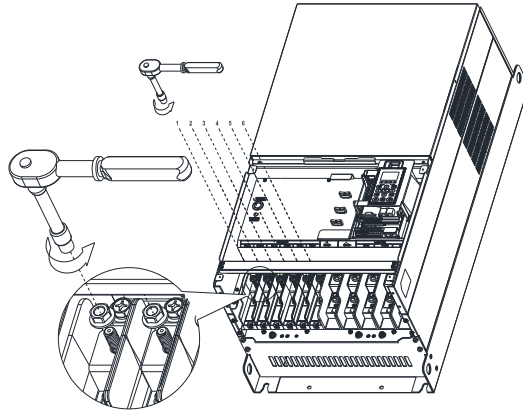

4. Install the 3pcs copper assy., as shown in the following figure 1. Fasten the upper M8 nuts (1~6) with a sleeve wrench (12mm of the sleeve), as shown in the figure 2 below.

M8 Torque: 180 kg-cm / [156.2 lb-in] / [17.65 Nm]

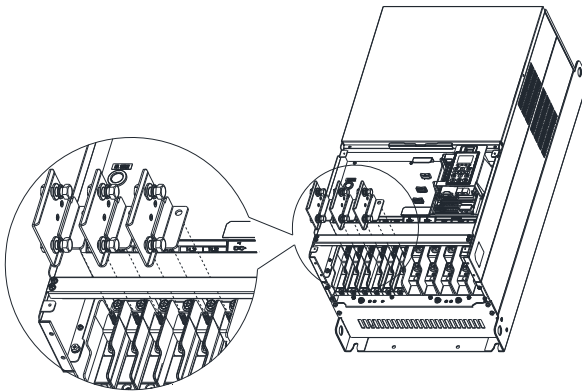

Figure 1

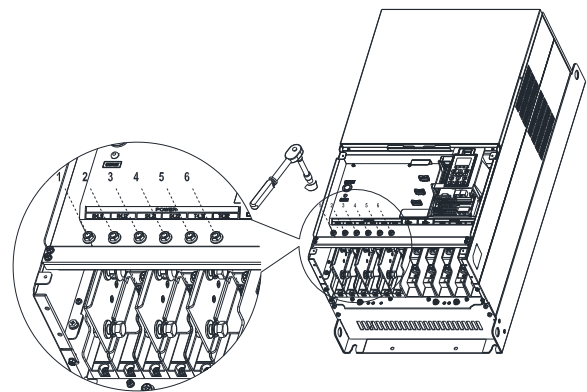

Figure 2

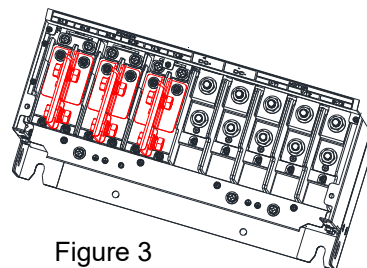
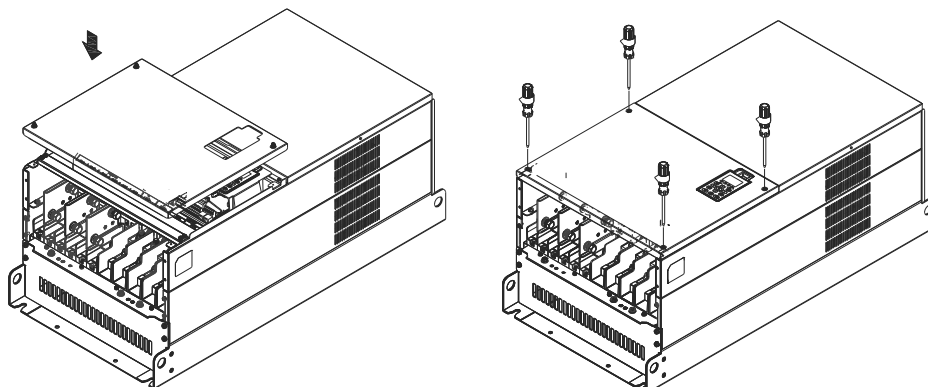

Figure 3

Copper Assy. Installation complete

5. Put the cover back and fasten the screws as shown in the figure below. Screw Torque: 12~15 kg-cm / [10.4~13 lb-in] / [1.2~1.5 Nm]





## 7-12 USB/RS-485 Communication Interface IFD6530

### Warning

- ✓ Please thoroughly read this instruction sheet before installation and putting it into use.
- ✓ The content of this instruction sheet and the driver file may be revised without prior notice.

Please consult our distributors or download the most updated instruction/ driver version at [http://www.delta.com.tw/product/em/control/cm/control\\_cm\\_main.asp](http://www.delta.com.tw/product/em/control/cm/control_cm_main.asp)

### 1. Introduction

IFD6530 is a convenient RS485-to-USB converter, which does not require external power-supply and complex setting process. It supports baud rate from 75 to 115.2Kbps and auto switching direction of data transmission. In addition, it adopts RJ-45 in RS485 connector for users to wire conveniently. And its tiny dimension, handy use of plug-and-play and hot-swap provide more conveniences for connecting all DELTA IABG products to your PC.

Applicable Models: All DELTA IABG products.

#### (Application & Dimension)

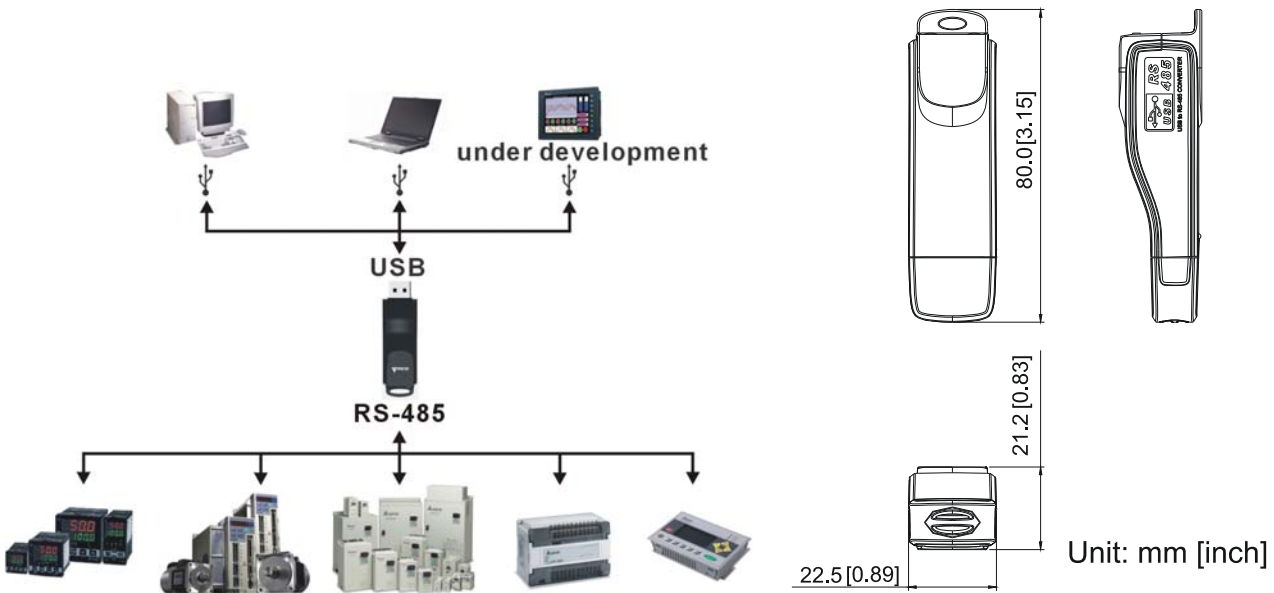

### 2. Specifications

Power supply	No external power is needed
Power consumption	1.5W
Isolated voltage	2,500V <sub>DC</sub>
Baud rate	75Kbps, 150Kbps, 300Kbps, 600Kbps, 1,200Kbps, 2,400Kbps, 4,800Kbps, 9,600Kbps, 19,200Kbps, 38,400Kbps, 57,600Kbps, 115,200Kbps
RS-485 connector	RJ-45
USB connector	A type (plug)
Compatibility	Full compliance with USB V2.0 specification
Max. cable length	RS-485 Communication Port: 100 m
Support RS-485 half-duplex transmission	

Table 7-73

### ■ RJ-45



PIN	Description
1	Reserved
2	Reserved
3	GND
4	SG-

PIN	Description
5	SG+
6	GND
7	Reserved
8	+9V

### 3. Preparations before Driver Installation

Please extract the driver file (IFD6530\_Drivers.exe) by following steps.

You could find driver file (IFD6530\_Drivers.exe) in the CD supplied with IFD6530.

**Note:** DO NOT connect IFD6530 to PC before extracting the driver file.

#### STEP 1

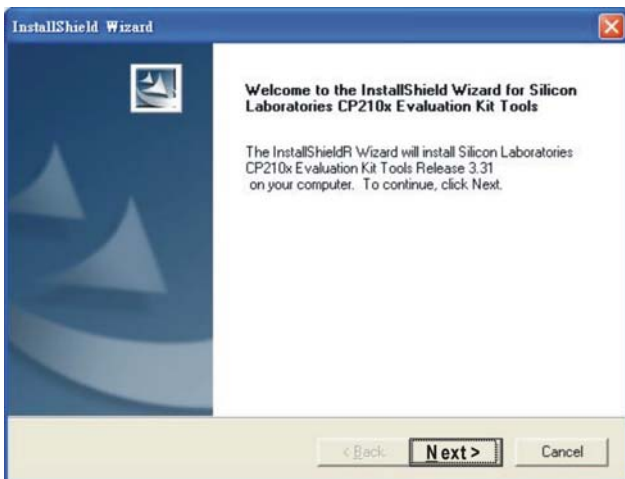

#### STEP 2

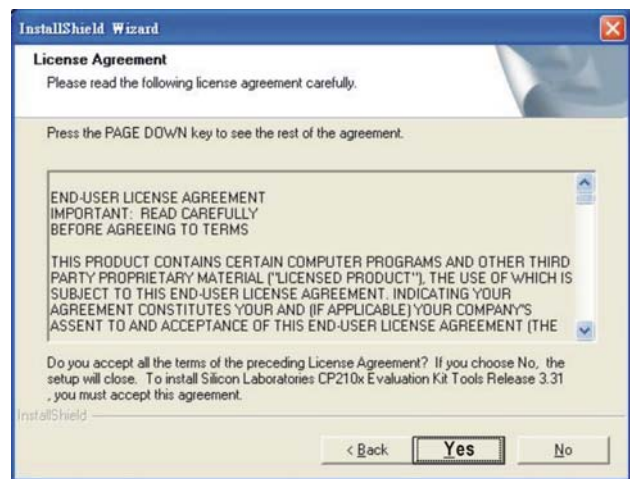

#### STEP 3

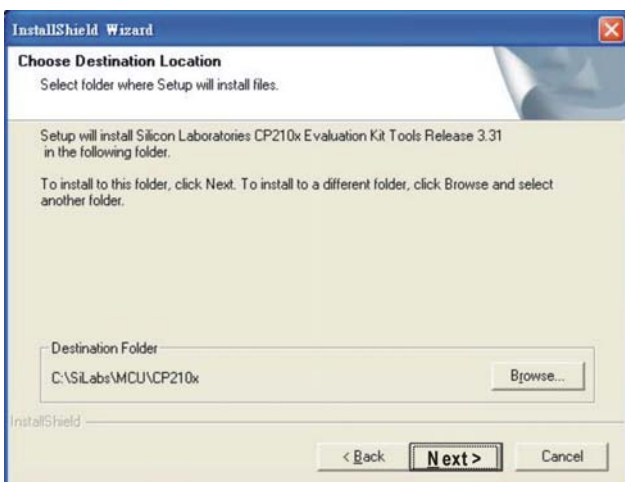

#### STEP 4



#### STEP 5

You should have a folder marked SiLabs under drive C. c:\ SiLabs

### 4. Driver Installation

After connecting IFD6530 to PC, please install driver by following steps.

#### STEP 1



#### STEP 2

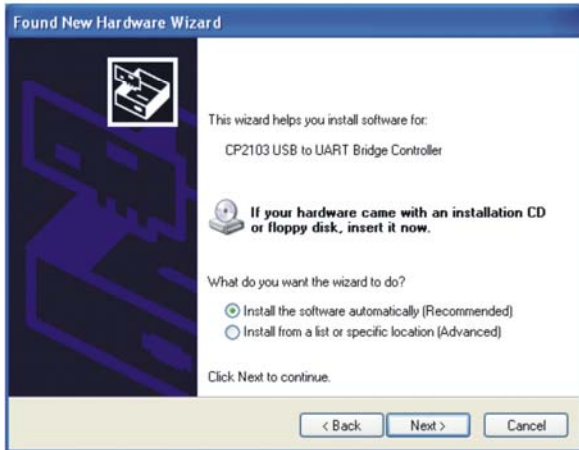

OR

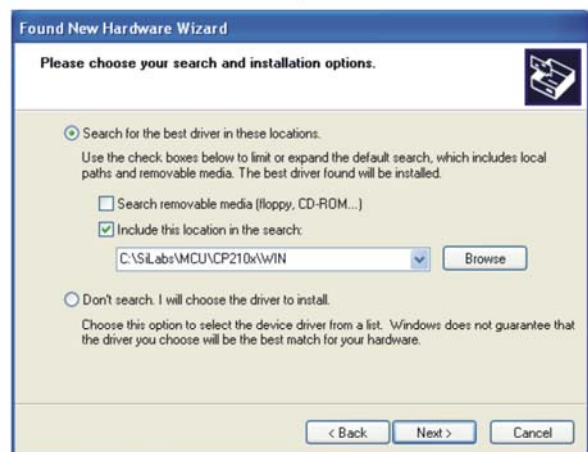
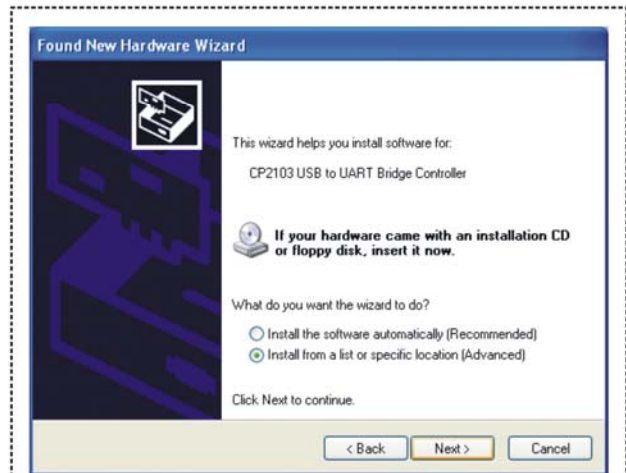

Browse and select directory, or enter  
C:\SiLabs\MCU\CP210x\WIN

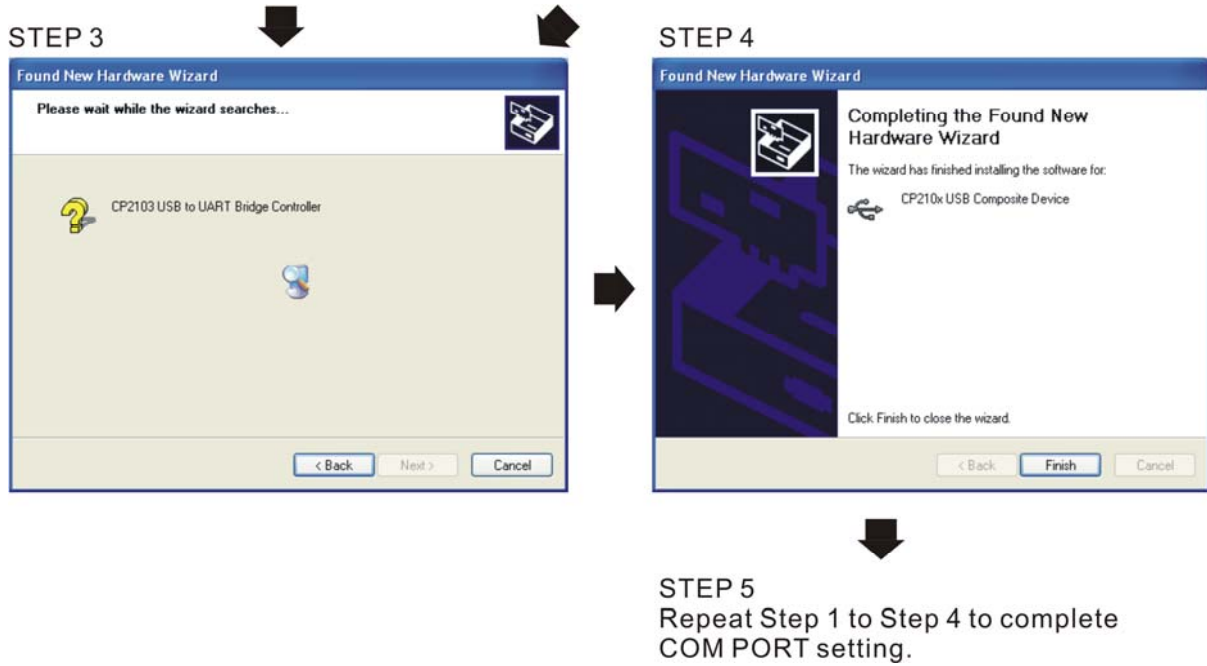

## 5. LED Display

1. Steady Green LED ON: power is ON.
2. Blinking orange LED: data is transmitting.

[This page intentionally left blank]

# Chapter 8 Option Cards

---

8-1 Option Card Installation

8-2 EMC-D42A -- Extension card for 4-point digital input/ 2-point digital input

8-3 EMC-D611A -- Extension card for 6-point digital input (110V<sub>AC</sub> input voltage)

8-4 EMC-R6AA -- Relay output extension card (6-point N.O. output contact)

8-5 EMC-A22A -- Extension card for 2-point analog input/ 2-point analog output

8-6 EMC-BPS01 -- +24V power card

8-7 EMC-PG01L / EMC-PG02L -- PG card (Line driver)

8-8 EMC-PG01O / EMC-PG02O -- PG card (Open collector)

8-9 EMC-PG01U / EMC-PG02U -- PG card (ABZ Incremental encoder signal/ UVW  
Hall position signal input)

8-10 EMC-PG01R -- PG card (Resolver)

8-11 CMC-MOD01 -- Communication card, Modbus TCP

8-12 CMC-PD01 -- Communication card, PROFIBUS DP

8-13 CMC-DN01 -- Communication card, DeviceNet

8-14 CMC-EIP01 -- Communication card, EtherNet/IP

8-15 CMC-EC01 -- Communication card, EtherCAT

8-16 CMC-PN01 -- Communication card, PROFINET

8-17 EMC-COP01 -- Communication card, CANopen

8-18 Delta Standard Fieldbus Cables

Please select applicable option cards for your drive or contact local distributor for suggestion. To prevent drive damage during installation, please remove the digital keypad and the cover before wiring. Refer to the following instruction.

## 8-1 Option Card Installation

### 8-1-1 Remove covers

Frame A–C

Screw Torque: 8–10 kg-cm / [6.9–8.7 lb-in.] / [0.8–1.0 Nm]

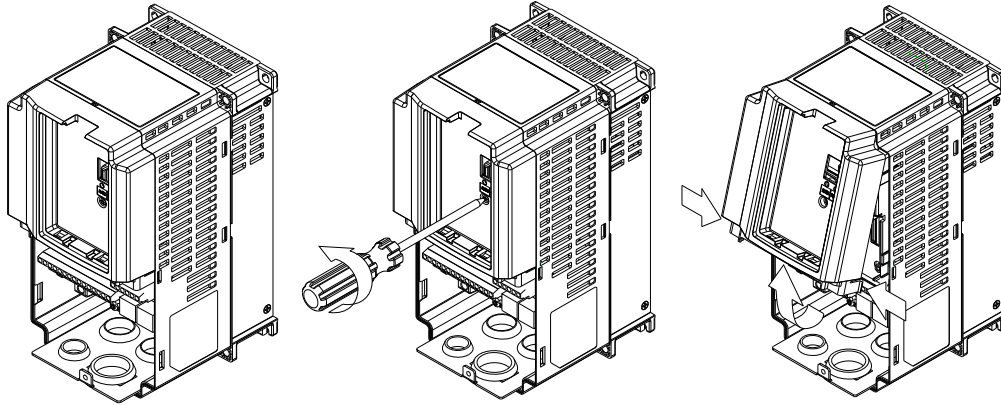

Frame D0

Screw Torque: 8–10 kg-cm / [6.9–8.7 lb-in.] / [0.8–1.0 Nm]

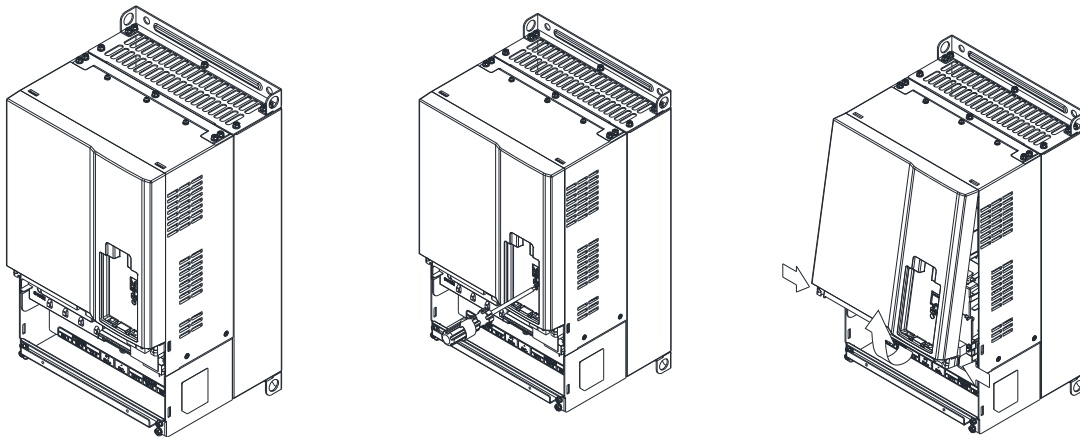

Frame D

Screw Torque: 8–10 kg-cm / [6.9–8.7 lb-in.] / [0.8–1.0 Nm]

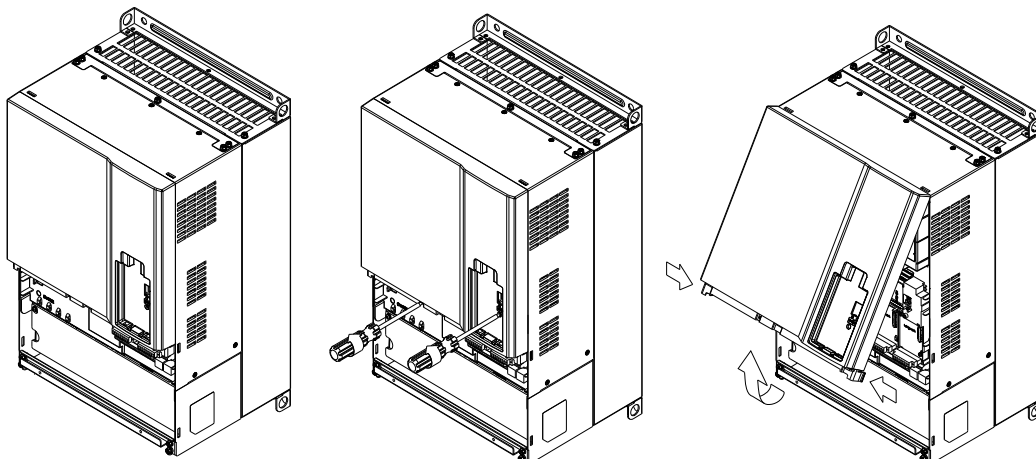

Frame E

Screw Torque: 12–15 kg-cm / [10.4–13 lb-in.] / [1.2–1.5 Nm]

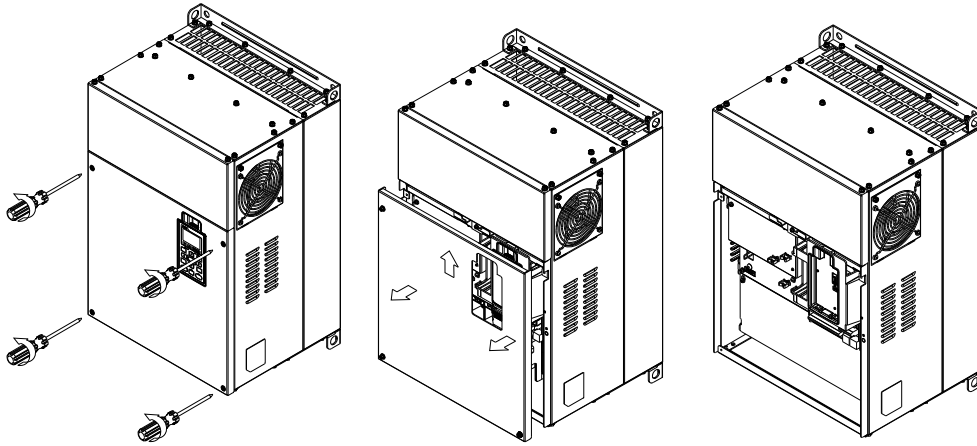

Frame F

Screw Torque: 12–15 kg-cm / [10.4–13 lb-in.] / [1.2–1.5 Nm]

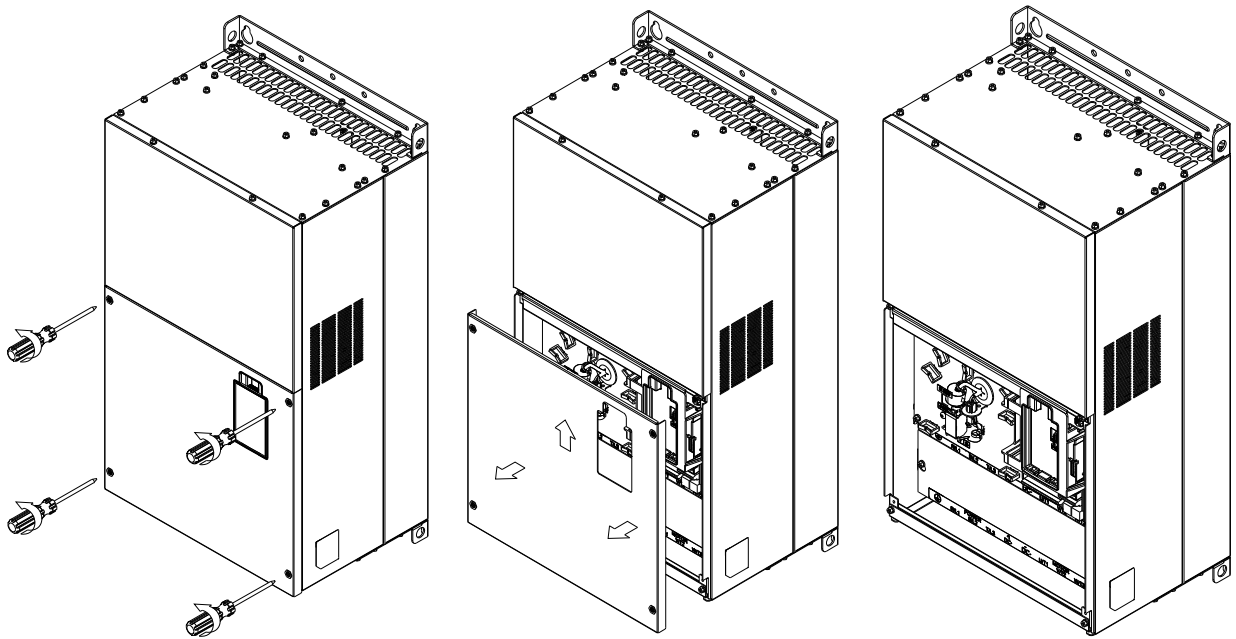

Frame G

Screw Torque: 12–15 kg-cm / [10.4–13 lb-in.] / [1.2–1.5 Nm]

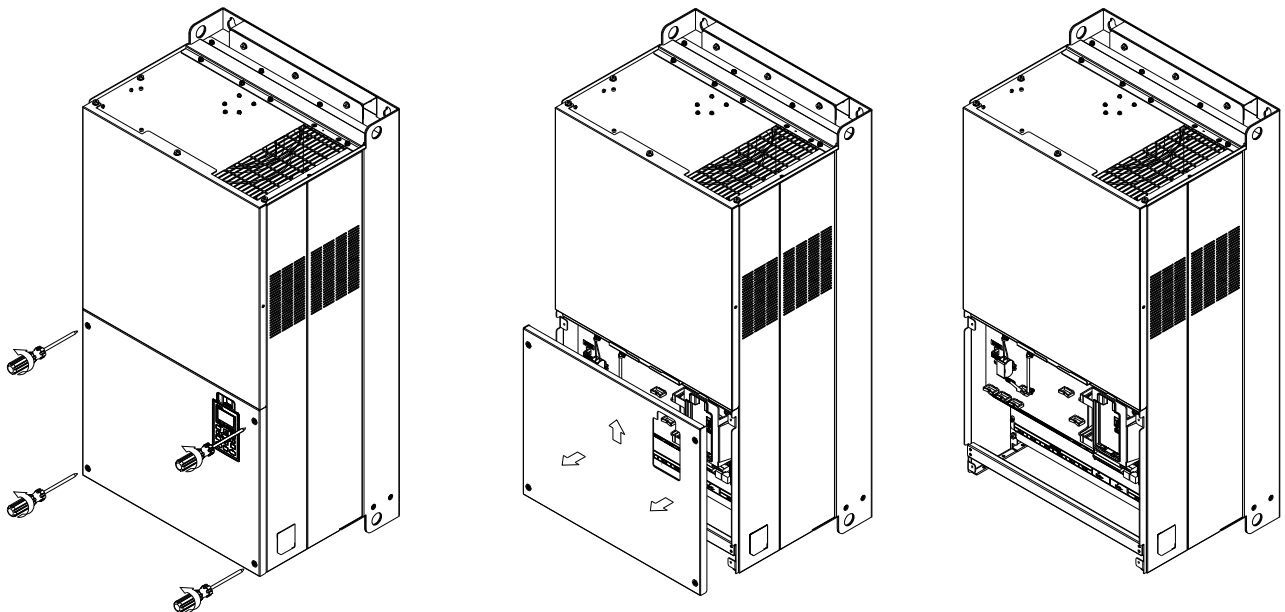



Frame H

Screw Torque: 14–16 kg-cm / [12.15–13.89 lb-in.] / [1.4–1.6 Nm]

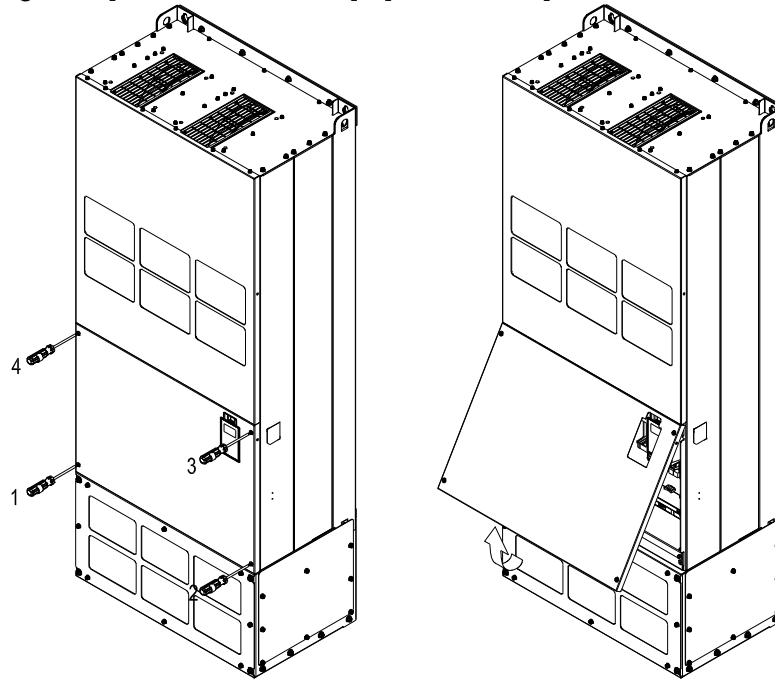

8-1-2 Option Card Installation Location

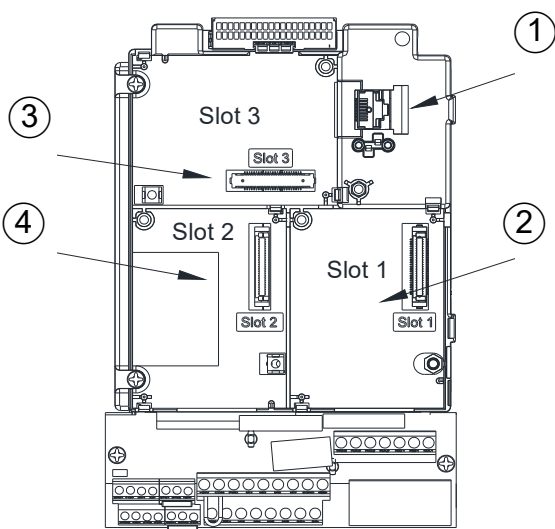

1	<p>RJ45 (Socket) for digital keypad KPC-CC01 Please refer to CH10 Digital Keypad for more details on KPC-CC01. Please refer to CH10 Digital Keypad for more details on optional accessory RJ45 extension cable.</p>
2	<p>Communication extension card (Slot 1) CMC-MOD01; CMC-PD01; CMC-DN01; CMC-EIP01; EMC-COP01; EMC-EC01; CMC-PN01</p>
3	<p>I/O &amp; Relay extension card (Slot 3) EMC-D42A; EMC-D611A; EMC-R6AA; EMC-BPS01; EMC-A22A</p>
4	<p>PG Card (Slot 2) EMC-PG01L; EMC-PG02L; EMC-PG01O; EMC-PG02O; EMC-PG01U; EMC-PG02U; EMC-PG01R;</p>

**Screws Specification for option card terminals:**

EMC-D42A; EMC-D611A; EMC-BPS01	Wire gauge	0.2–0.5 mm <sup>2</sup> [26–20 AWG]
	Torque	5 kg-cm / [4.4 lb-in] / [0.5 Nm]
EMC-R6AA	Wire gauge	0.2–0.5 mm <sup>2</sup> [26–20 AWG]
	Torque	8 kg-cm / [7 lb-in] / [0.8 Nm]
EMC-PG01L; EMC-PG01O EMC-PG01R; EMC-PG01U	Wire gauge	0.2–0.5 mm <sup>2</sup> [26–20 AWG]
	Torque	2 kg-cm / [1.73 lb-in] / [0.2 Nm]

I/O & Relay extension card (Slot 3)

EMC-D42A

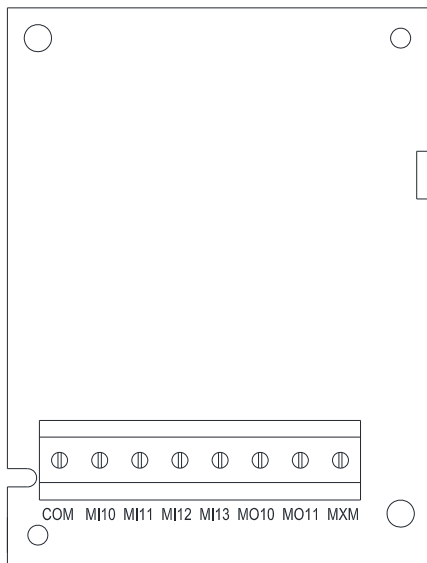

EMC-R6AA

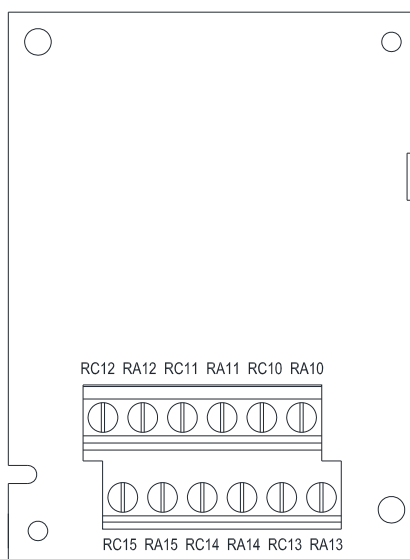

EMC-BPS01

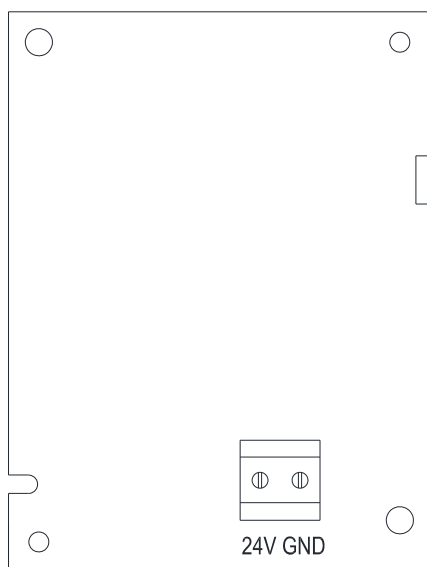

EMC-D611A

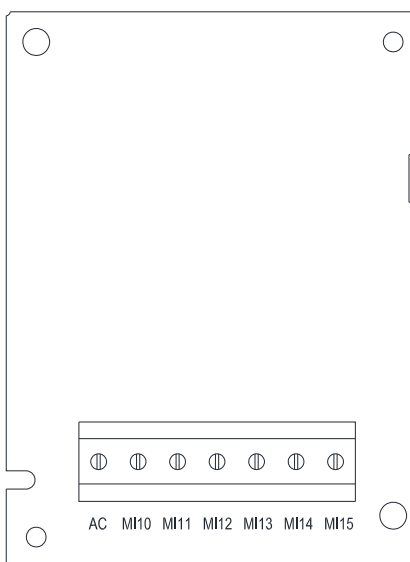

EMC-A22A

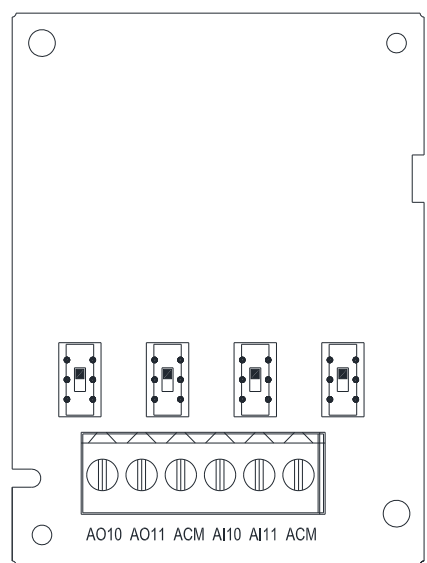

PG card (Slot 2)

EMC-PG010 / EMC-PG020

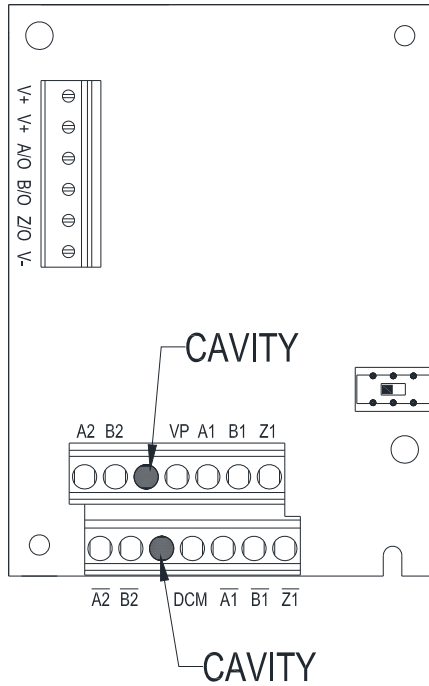

EMC-PG01L / EMC-PG02L

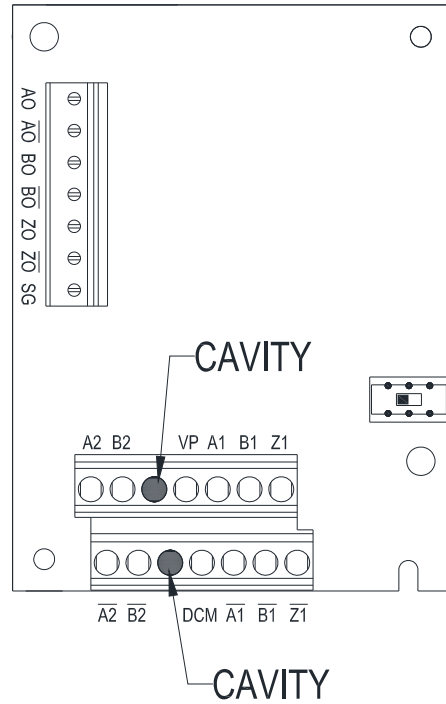

EMC-PG01U / EMC-PG02U

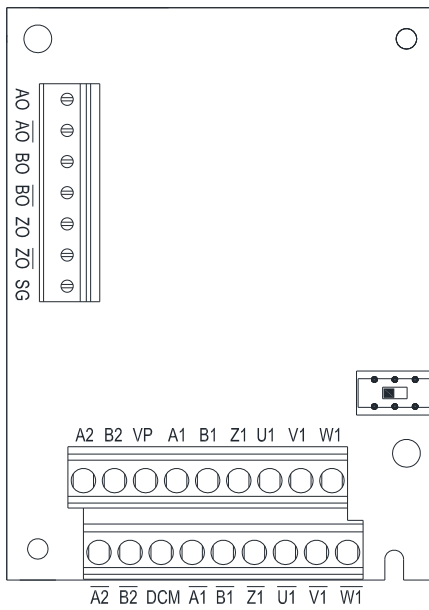

EMC-PG01R

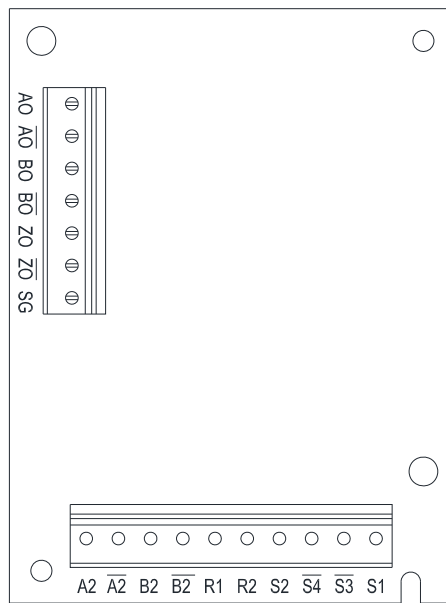

Communication extension card (Slot 1)

CMC-PD01

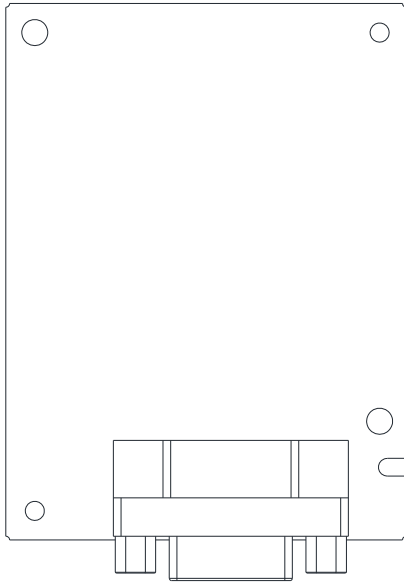

CMC-DN01

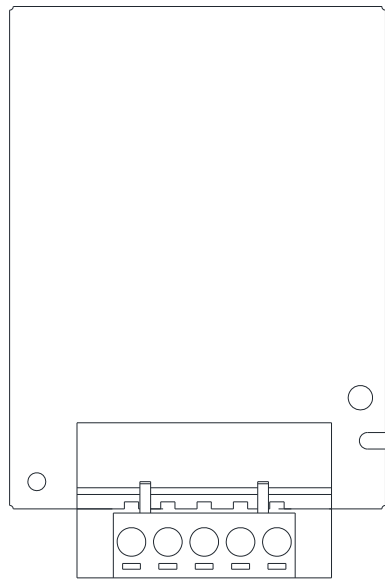

CMC-MOD01 / CMC-EIP01

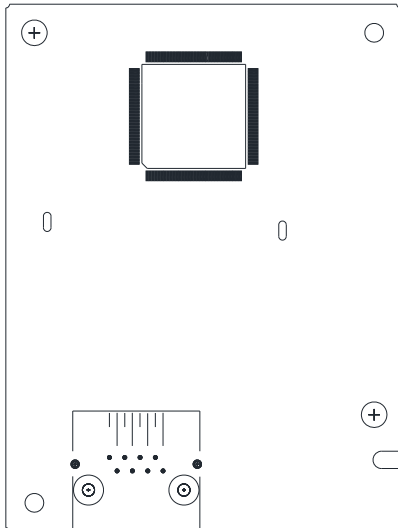

EMC-COP01

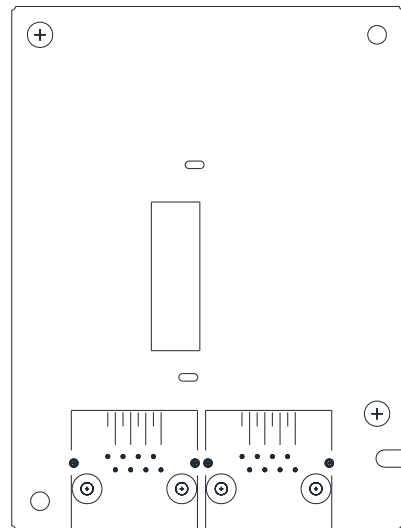

CMC-EC01

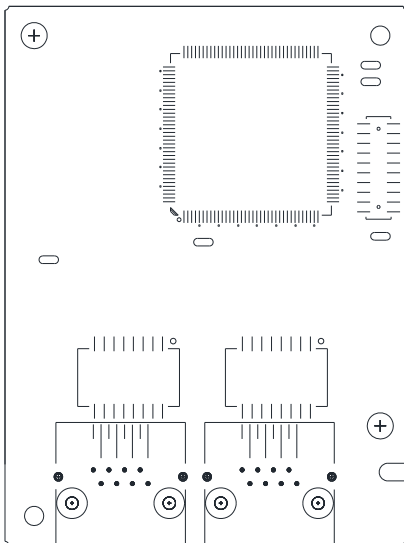

CMC-PN01

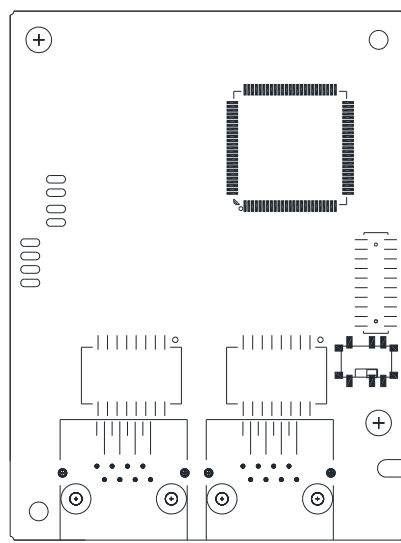

### 8-1-3 Installation and Disconnection of Extension Card

#### 8-1-3-1 Installation

Communication card: EMC-COP01, CMC-MOD01, CMC-EIP01, CMC-DN01, CMC-PD01, CMC-EC01, CMC-PN01

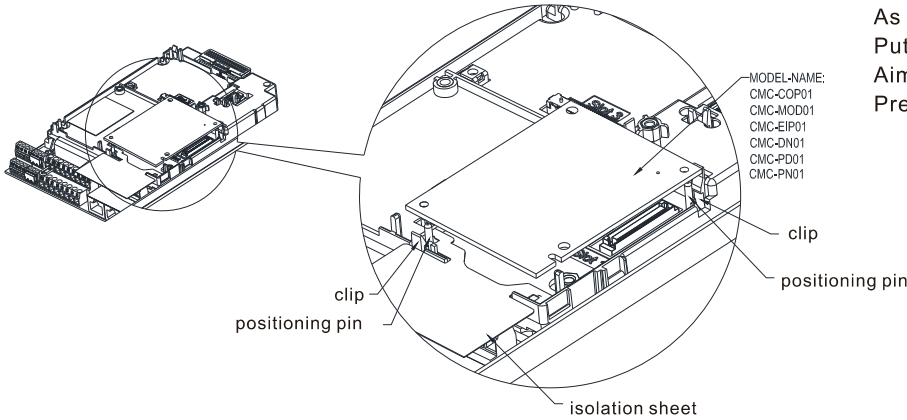

As shown in the figure on the left.  
Put the isolation sheet into the positioning pin.  
Aim the two holes at the positioning pin.  
Press the pin to clip the holes with the PCB.

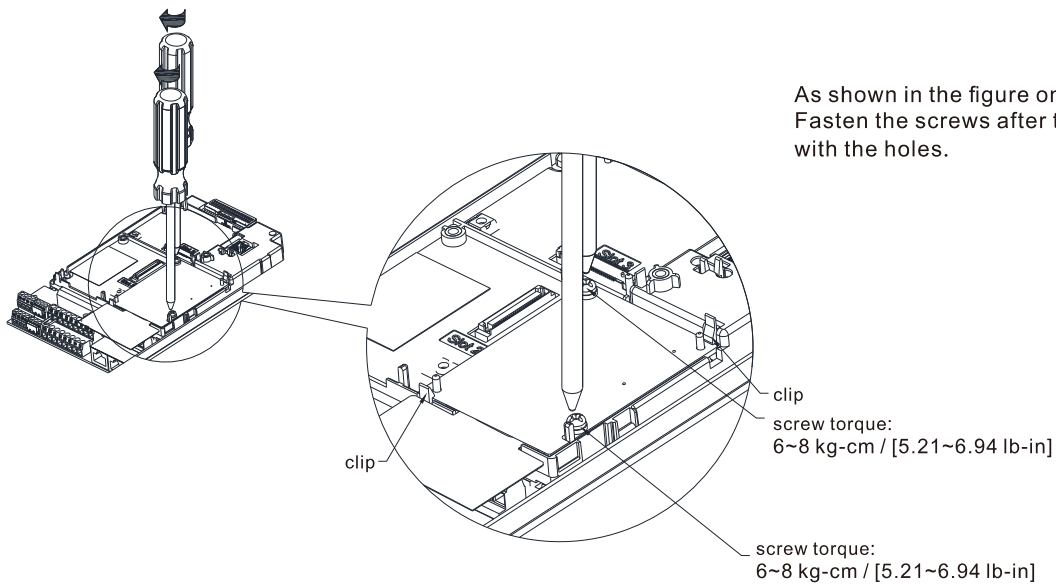

As shown in the figure on the left.  
Fasten the screws after the PCB is clipped with the holes.

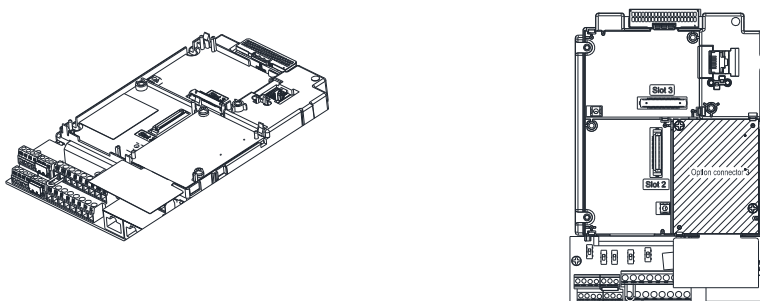

As shown in the figure on the left,  
installation is completed.

I/O & Relay Card: EMC-D42A, EMC-D611A, EMC-R6AA, EMC-BPS01, EMC-A22A

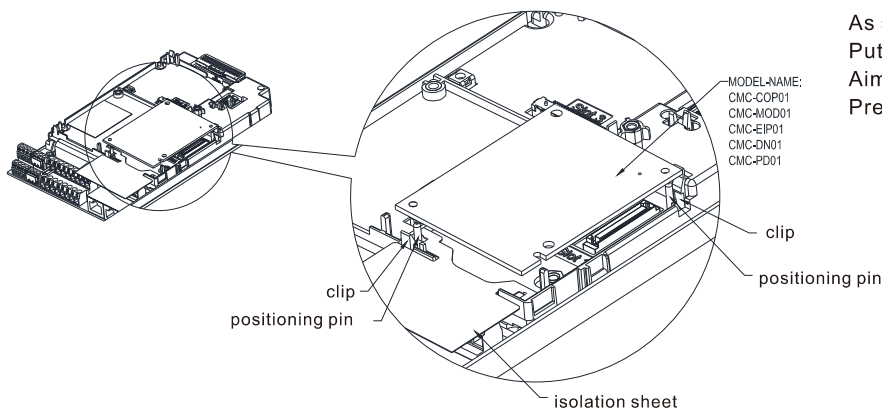

As shown in the figure on the left.  
 Put the isolation sheet into the positioning pin.  
 Aim the two holes at the positioning pin.  
 Press the pin to clip the holes with the PCB.

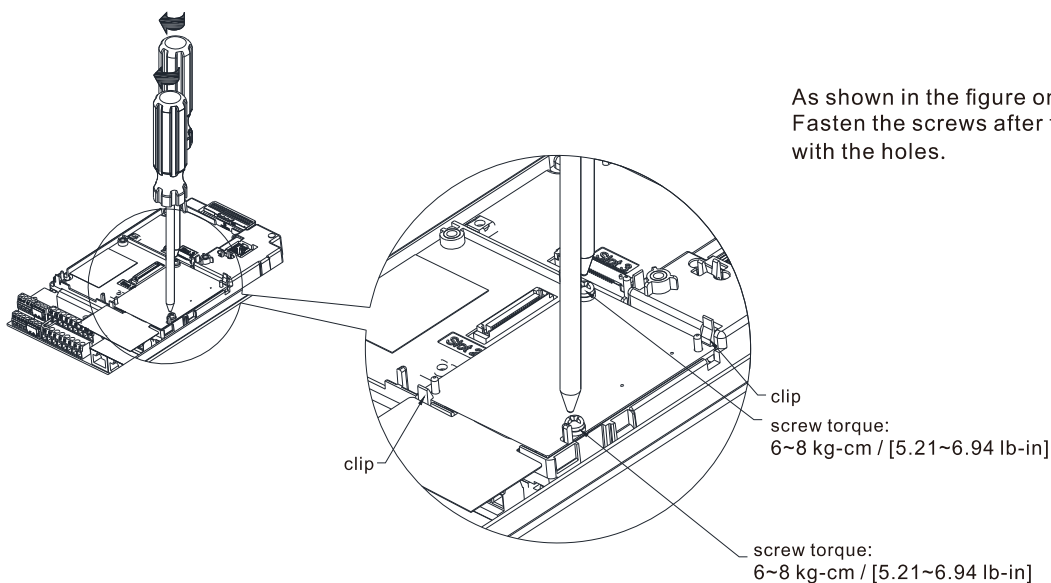

As shown in the figure on the left.  
 Fasten the screws after the PCB is clipped  
 with the holes.

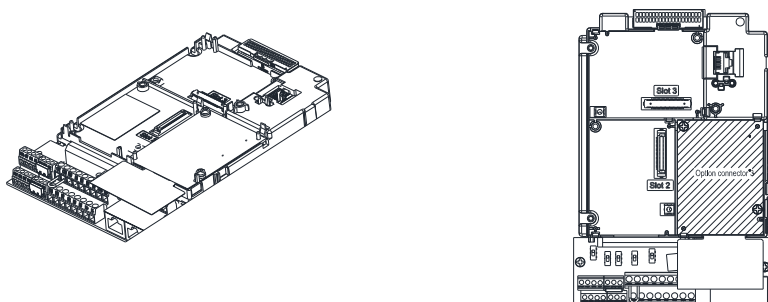

As shown in the figure on the left,  
 installation is completed.

PG Card: EMC-PG01U, EMC-PG01R, EMC-PG01L, EMC-PG01O

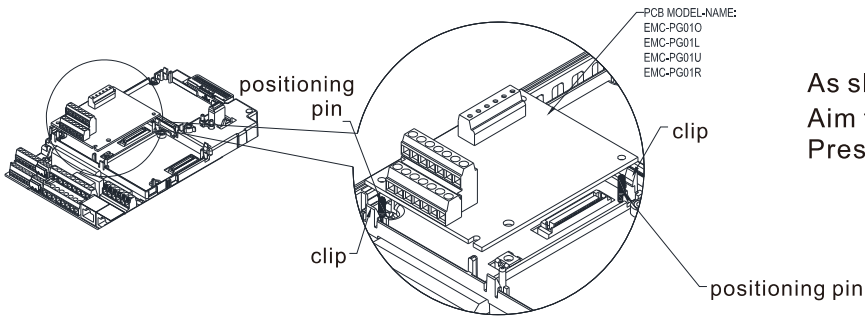

As shown in the figure on the left.  
Aim the two holes at the positioning pin.  
Press the pin to clip the holes with the PCB.

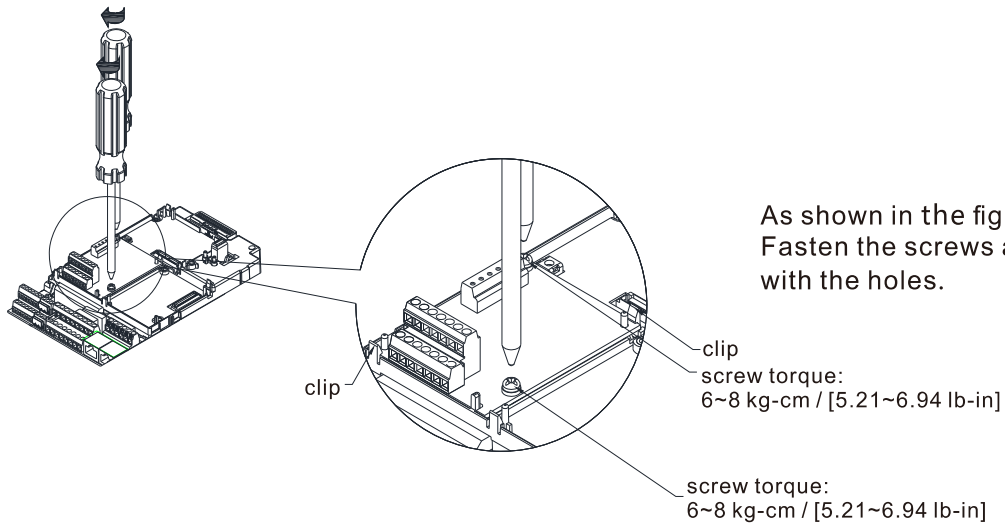

As shown in the figure on the left.  
Fasten the screws after PCB is clipped  
with the holes.

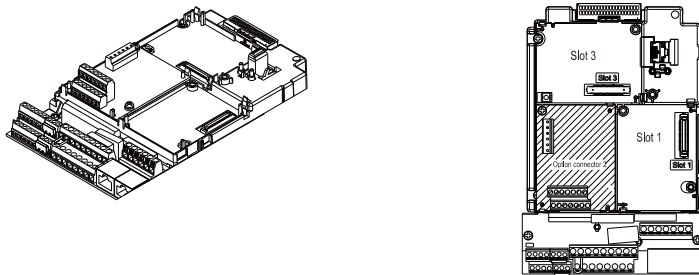

As shown in the figure on the left,  
installation is completed.

### 8-1-3-2 Disconnecting the extension card

Communication card: EMC-COP01, CMC-MOD01, CMC-EIP01, CMC-DN01, CMC-PD01, CMC-EC01, CMC-PN01

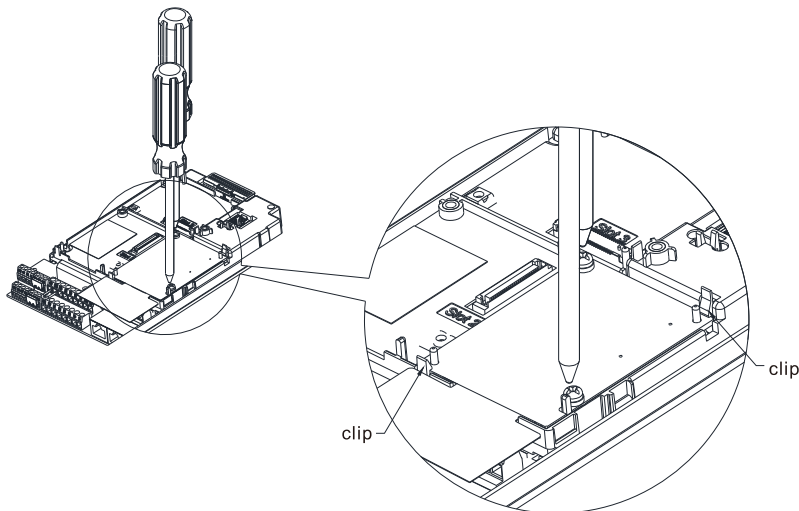

Remove the two screws as shown in the figure on the left.

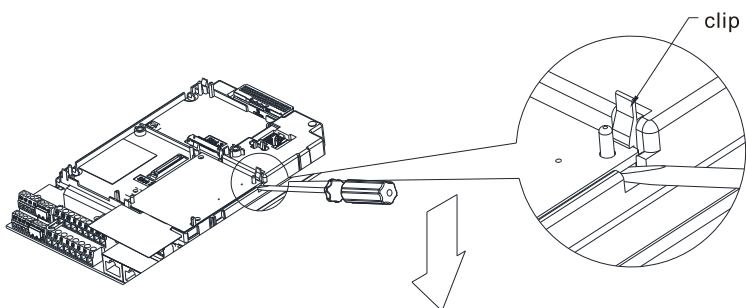

As shown in the figure on the left. Twist to open the clip. Insert a slot type screwdriver into the hollow to prize the PCB off the clip.

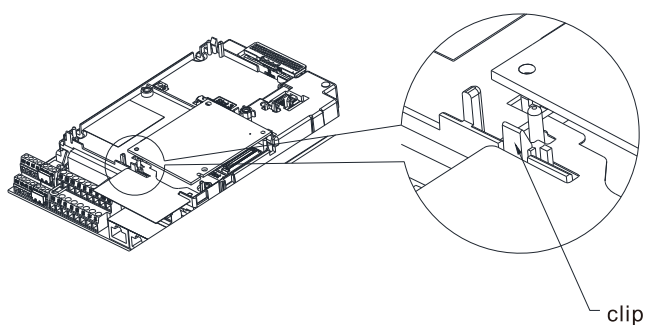

As shown in the figure on the left. Twist to open the other clip to remove the PCB.



I/O & Relay card: EMC-D42A, EMC-D611A, EMC-R6AA, EMC-BPS01, EMC-A22A

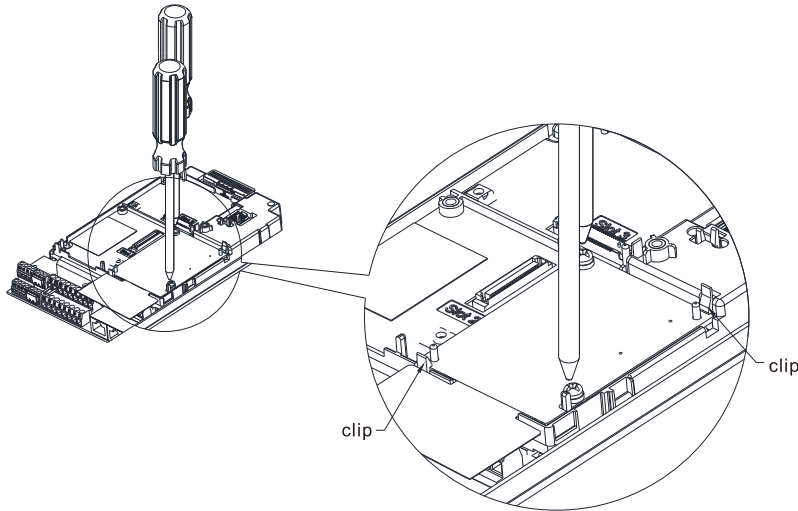

Remove the two screws as shown in the figure on the left.

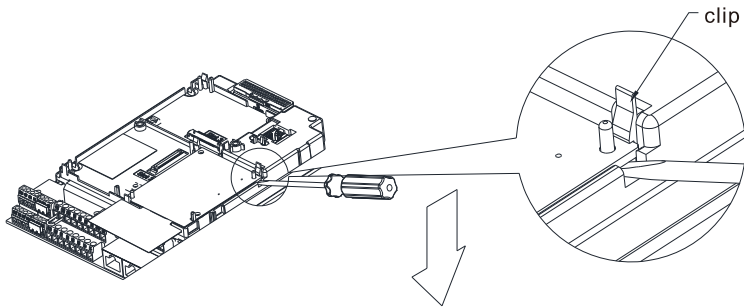

As shown in the figure on the left. Twist to open the clip. Insert a slot type screwdriver into the hollow to prize the PCB off the clip.

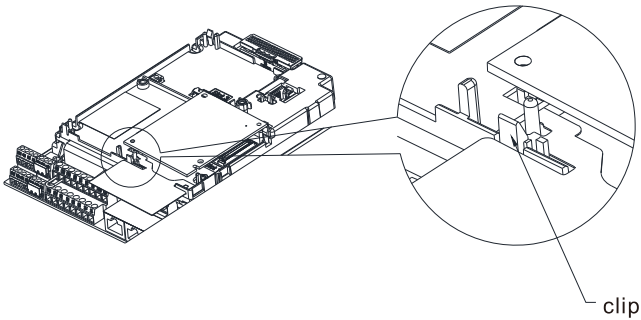

As shown in the figure on the left. Twist to open the other clip to remove the PCB.

PG card: EMC-PG01U, EMC-PG01R, EMC-PG01L, EMC-PG01O

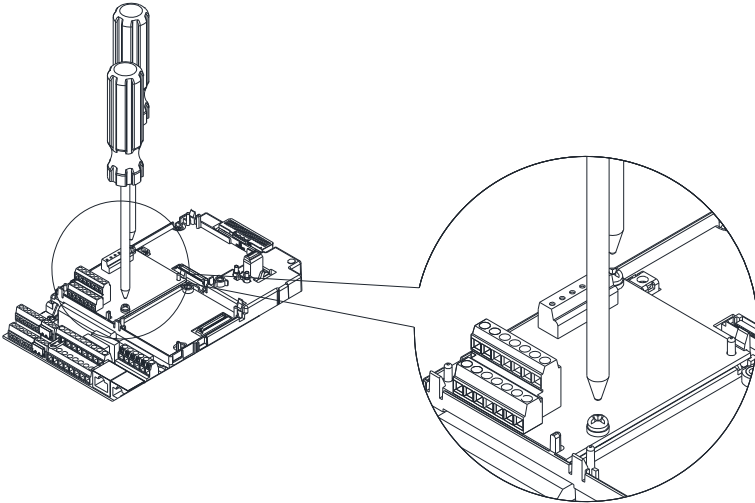

Remove the two screws as shown in the figure on the left.

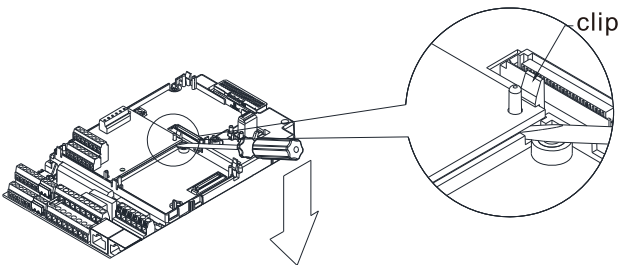

As shown in the figure on the left. Twist to open the clip. Insert a slot type screwdriver into the hollow to prize the PCB off the clip.

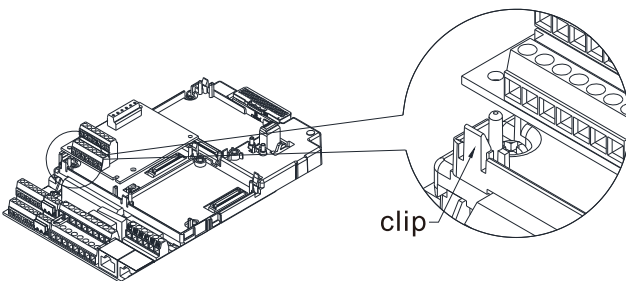

As shown in the figure on the left. Twist to open the other clip to remove the PCB.

**8-2 EMC-D42A** -- Extension card for 4-point digital input/ 2-point digital input

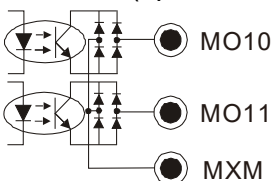
	Terminals	Descriptions
I/O Extension Card	COM	Common for Multi-function input terminals Select SINK (NPN) / SOURCE (PNP) in J1 jumper / external power supply
	MI10–MI13	Refer to parameters 02-26–02-29 to program the multi-function inputs MI10–MI13. Internal power is applied from terminal E24: +24V <sub>DC</sub> ±5% 200mA, 5W External power +24V <sub>DC</sub> : max. voltage 30V <sub>DC</sub> , min. voltage 19V <sub>DC</sub> , 30W ON: the activation current is 6.5mA OFF: leakage current tolerance is 10µA
	MO10–MO11	Multi-function output terminals (photocoupler) The AC motor drive releases various monitor signals, such as drive in operation, frequency attained and overload indication, via transistor (open collector). 
	MXM	Common for multi-function output terminals MO10, MO11(photocoupler) Max 48V <sub>DC</sub> 50mA

**8-3 EMC-D611A** -- Extension card for 6-point digital input (110V<sub>AC</sub> input voltage)

	Terminals	Descriptions
I/O Extension Card	AC	AC power Common for multi-function input terminal (Neutral)
	MI10–MI15	Refer to Pr. 02-26–Pr. 02-31 for multi-function input selection Input voltage: 100–130V <sub>AC</sub> Input frequency: 47–63Hz Input impedance: 27Kohm Terminal response time: ON: 10ms OFF: 20ms

**8-4 EMC-R6AA** -- Relay output extension card (6-point N.O. output contact)

	Terminals	Descriptions
Relay Extension Card	RA10–RA15 RC10–RC15	Refer to Pr. 02-36– Pr. 02-41 for multi-function output selection Resistive load: 3A (N.O.) / 250V <sub>AC</sub> 5A (N.O.) / 30V <sub>DC</sub> Inductive load (COS 0.4) 1.2A (N.O.) / 250V <sub>AC</sub> 2.0A (N.O.) / 30V <sub>DC</sub> It is used to output each monitor signal, such as drive is in operation, frequency attained or overload indication.

**8-5 EMC-A22A** -- Extension card for 2-point analog input/ 2-point analog output

	Terminals	Descriptions
Analog I/O Extension Card	AI10, AI11	Refer to Pr. 14-00–Pr. 14-01 for function selection (input), and Pr. 14-18–Pr. 14-19 for mode selection. There are two sets of AI port, SSW3 (AI10) and SSW4 (AI11), which can be switched to Voltage or Current mode. Voltage mode: Input 0–10V Current mode: Input 0–20mA / 4–20mA
	AO10, AO11	Refer to Pr. 14-12–Pr. 14-13 for function selection (output), and Pr. 14-36–Pr. 14-37 for mode selection. There are two sets of AO port, SSW1 (AO10) and SSW2 (AO11), which can be switched to Voltage or Current mode. Voltage mode: Output 0–10V Current mode: Output 0–20mA / 4–20mA
	ACM	Analog signal common terminal

**8-6 EMC-BPS01** -- +24V power card

	Terminals	Descriptions
External Power Supply		Input power: 24V±5% Maximum input current: 0.5A Note: 1) Do not connect drive control terminal GND directly to the EMC-BPS01 input terminal GND.
	24V GND	Function: When the drive is only powered by EMC-BPS01, the communication can be assured and support all communication cards and following functions: Parameters read and write Keypad can be displayed Keypad button can be operated (except RUN) Analog input is effective Multi-input (FWD, REV, MI1–MI8) needs external power supply to operate Following functions are not supported : Relay output (including extension card), PG card, PLC function

Note: Refer to I/O & Relay extension card installation/ disconnecting method for PG Card installation/ disconnecting.

## 8-7 EMC-PG01L / EMC-PG02L -- PG card (Line driver)

### 8-7-1 Terminal description

Set by Pr.10-00–10-02, Pr.10-16–10-18

Terminals		Descriptions
PG1	VP	Output voltage for power: +5V/+12V±5% (use FSW3 to switch +5V/+12V) Max. output current: 200mA
	DCM	Common for power and signal
	A1, /A1, B1, /B1, Z1, /Z1	Encoder input signal (Line Driver or Open Collector) Open Collector input voltage: +5–+24V (Note 1) It can be 1-phase or 2-phase input. EMC-PG01L: Max. input frequency: 300kHz EMC-PG02L: Max. input frequency: 30kHz (Note 2)
PG2	A2, /A2, B2, /B2	Pulse Input signal (Line Driver or Open Collector) Open Collector input voltage: +5–+24V (Note1) It can be 1-phase or 2-phase input. EMC-PG01L: Max. input frequency: 300kHz EMC-PG02L: Max. input frequency: 30kHz (Note 2)
PG OUT	AO, /AO, BO, /BO, ZO, /ZO, SG	PG Card Output signals. It has division frequency function: 1–255 times Max. output voltage for Line driver: 5V <sub>DC</sub> Max. output current: 15mA EMC-PG01L Max. output frequency: 300kHz EMC-PG02L Max. output frequency: 30kHz SG is the GND of PG card. It is also the GND of position machine or PLC to make the output signal to be the common pivot point.

Note 1: Open Collector application, input current 5–15mA to each set then each set needs one pull-up resistor. If input voltage of open collector is 24V, the power of encoder needs to be connected externally. Please refer to diagram 2 of PG1.

5V	Recommended pull-up resistor: above 100–220Ω, 1/2W
12V	Recommended pull-up resistor: above 510Ω–1.35kΩ, 1/2W
24V	Recommended pull-up resistor: above 1.8k–3.3kΩ, 1/2W

Note 2: If the required bandwidth is not over 30kHz at the application, it is recommended to use EMC-PG02O/L (bandwidth 30kHz) to avoid interference.

PG1 card wiring diagram (the image 1 and 2 below are wiring diagrams of Open Collector encoder)

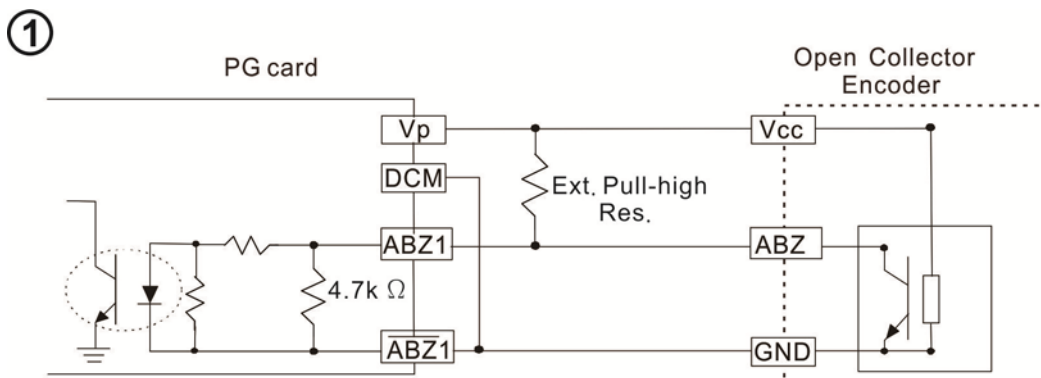

②

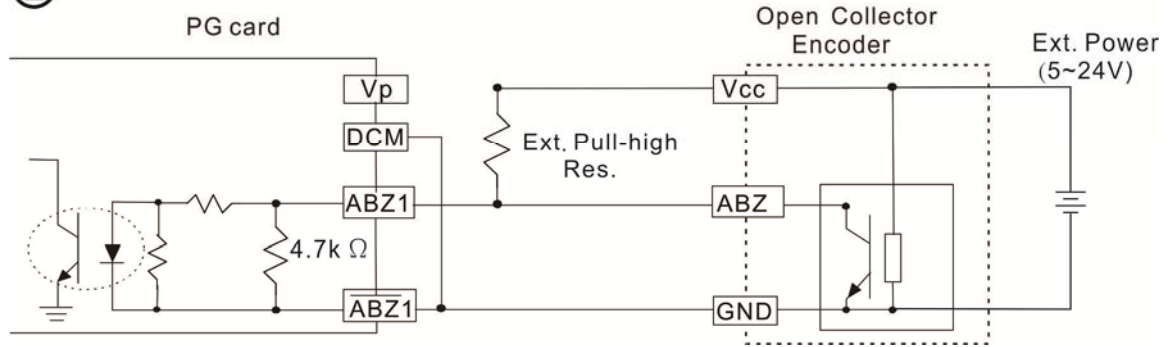

PG2 Wiring Diagram

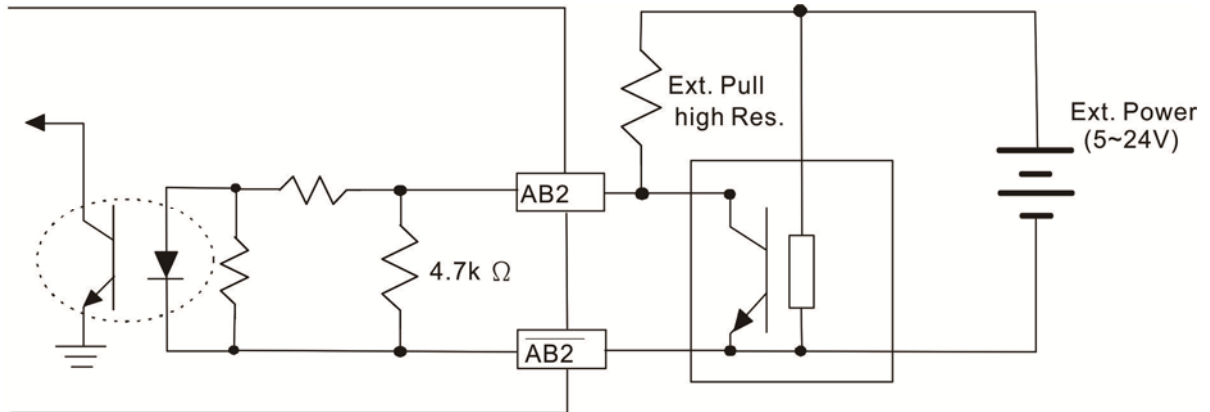

**8-7-2 EMC-PG01L / EMC-PG02L Wiring Diagram**

- ☑ Please use a shielded cable to prevent interference. Do not run control wires parallel to any high voltage AC power line (200 V<sub>AC</sub> and above).
- ☑ Recommended wire size 0.21–0.81mm<sup>2</sup> [AWG24–AWG18].
- ☑ Cable length: Single-phase input, less than 30m/ 2-phase input, less than 100m

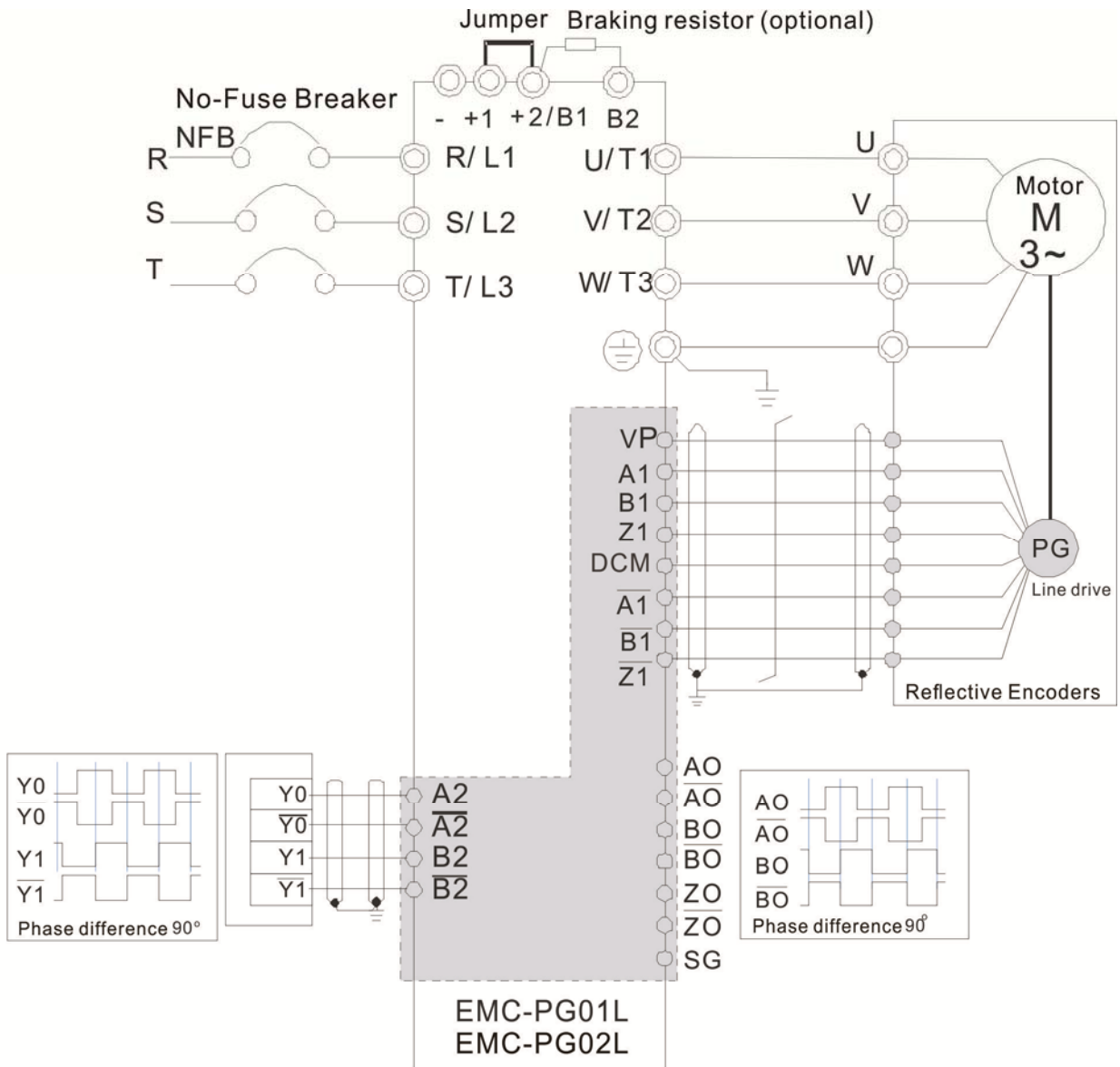

## 8-8 EMC-PG010 / EMC-PG020 -- PG card (Open collector)

### 8-8-1 Terminal descriptions

Set by Pr.10-00–10-02, Pr.10-16–10-18

Terminals		Descriptions
PG1	VP	Output voltage for power: +5V/+12V±5% (use FSW3 to switch +5V/+12V) Max. output current: 200mA
	DCM	Common for power and signal
	A1, /A1, B1, /B1, Z1, /Z1	Encoder Input signal (Line Driver or Open Collector) Open Collector Input Voltage: +5V–+24V (Note 1) It can be 1-phase or 2-phase input. EMC-PG010 Max. input frequency: 300kHz EMC-PG020 Max. input frequency: 30kHz (Note 2)
PG2	A2, /A2, B2, /B2	Pulse Input Signal (Line Driver or Open Collector) Open Collector Input Voltage: +5–+24V (Note 1) It can be 1-phase or 2-phase input. EMC-PG010 Max. input frequency: 300kHz EMC-PG020 Max. input frequency: 30kHz (Note 2)
PG OUT	V+, V+	Needs external power source for PG OUT circuit. Input voltage of power: +7V – +24V
	V-	Input voltage for the negative side
	A/O, B/O, Z/O	PG Card Output signals has division frequency function: 1–255 times. On the open collector's output signal, add a high-pull resistor on the external power V+–V- (e.g. power of PLC) to prevent the interference of the receiving signal. Max. [Three pull-up resistor are included in the package (1.8kΩ/1W)] (Note 1) EMC-PG010 Max. input frequency: 300kHz EMC-PG020 Max. input frequency: 30kHz

Note 1: Open Collector application, input current 5–15mA to each set then each set needs one pull-up resistor. If input voltage of open collector is 24V, the power of encoder needs to be connected externally. Please refer to diagram 2 of PG1.

5V	Recommended pull-up resistor: above 100–220Ω, 1/2W
12V	Recommended pull-up resistor: above 510Ω–1.35kΩ, 1/2W
24V	Recommended pull-up resistor: above 1.8k–3.3kΩ, 1/2W

Note 2: If the required bandwidth is not over 30kHz at the application, it is recommended to use EMC-PG020/L (bandwidth 30kHz) to avoid interference.



PG1 card wiring diagram (the image 1 and 2 below are wiring diagrams of Open Collector encoder)

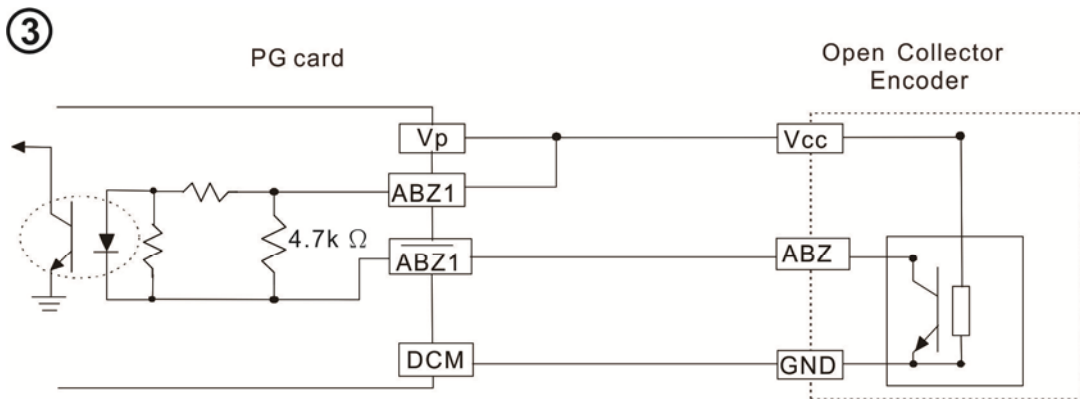
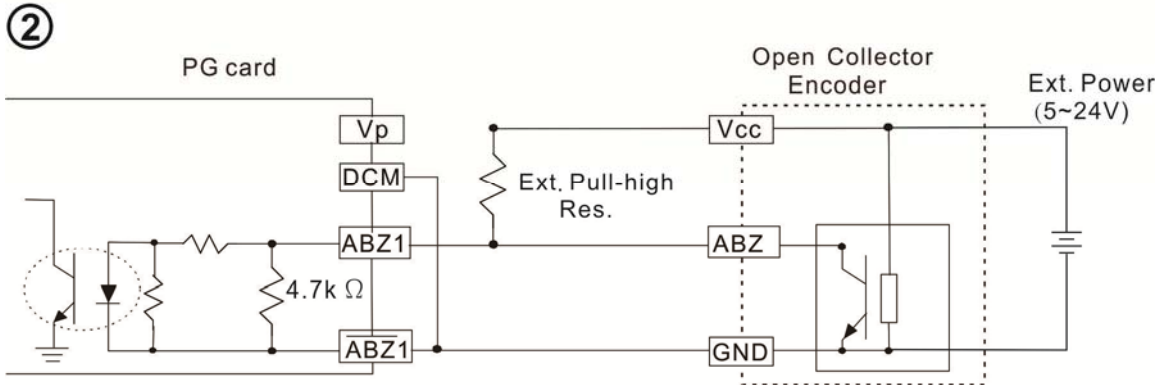
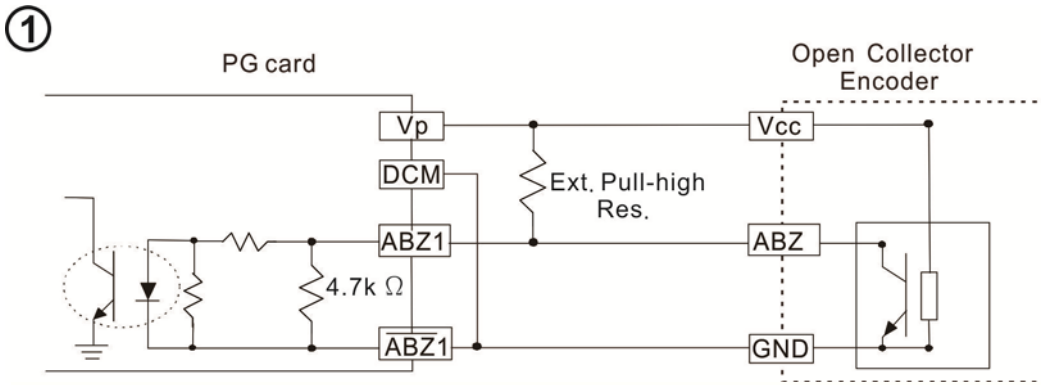

When wiring in this way, if there is a signal on EMC-PG010's A1, B1 and Z1, LED lights is OFF.

If A1, B1 and Z1 have no signals, LED lights is ON.

PG2 Wiring Diagram

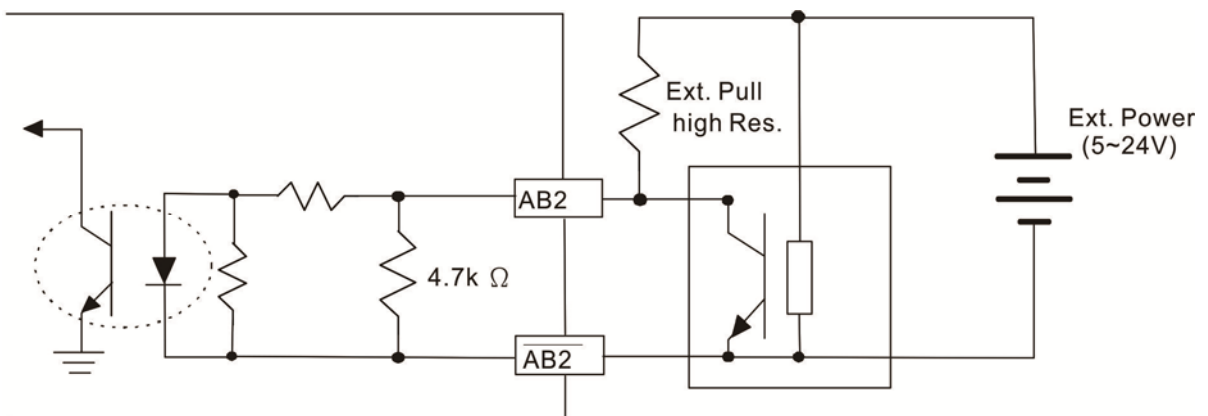

### 8-8-2 EMC-PG010 / EMC-PG020 Wiring Diagram

- ☑ Please use a shielded cable to prevent interference. Do not run control wires parallel to any high voltage AC power line (200 V<sub>AC</sub> and above).
- ☑ Recommended wire size 0.21–0.81mm<sup>2</sup> [AWG24–AWG18].
- ☑ Cable length: Single-phase input, less than 30m/ 2-phase input, less than 100m

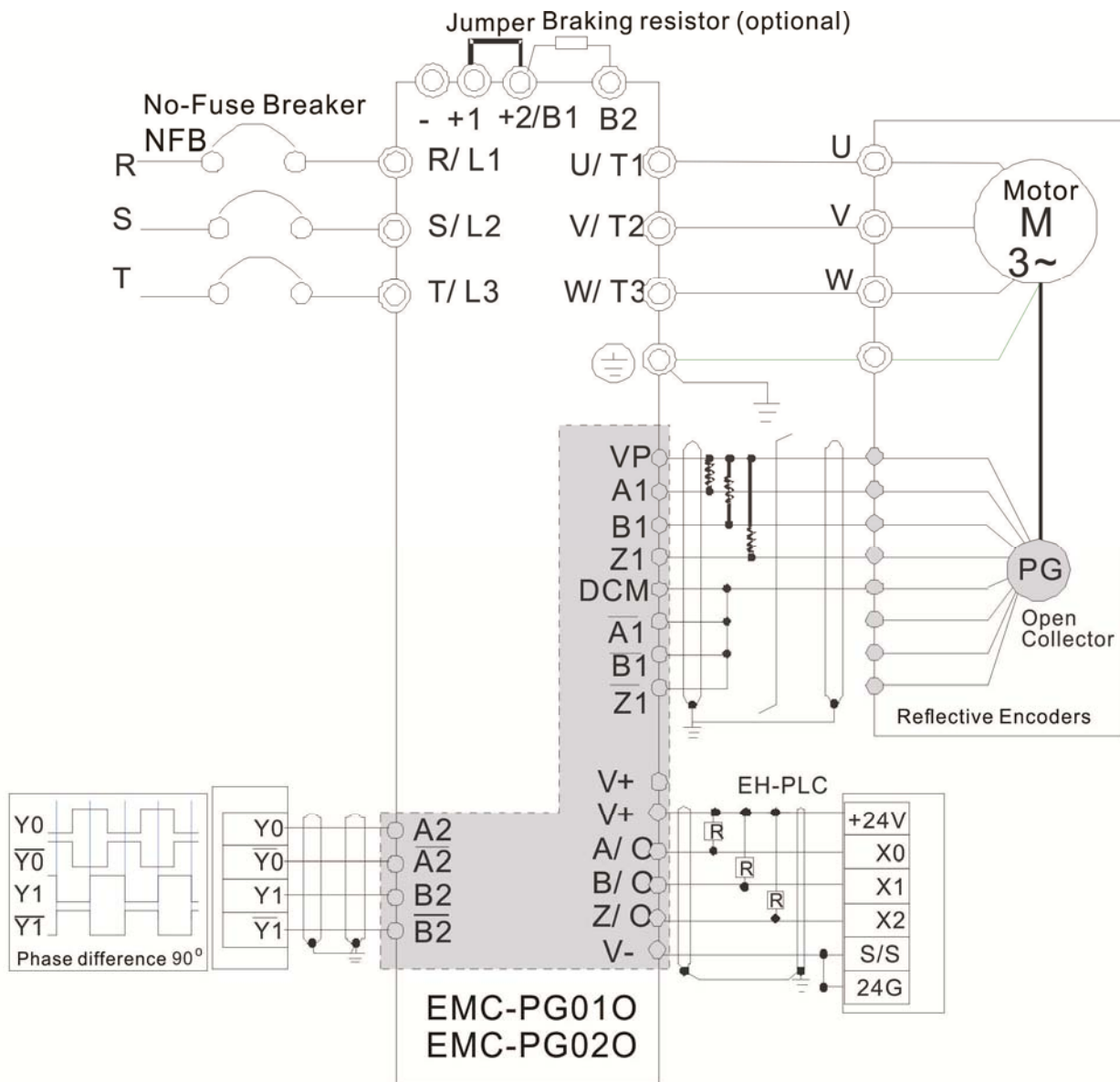

### 8-9 EMC-PG01U / EMC-PG02U

-- PG card (ABZ Incremental encoder signal/ UVW Hall position signal input)

1. FSW1 **S**: Standard UVW Output Encoder; **D**: Delta Encoder
2. When using the Delta Encoder, wait for at least 250ms after powering up to receive signals from UVW. If a running command is received before UVW signals finish, a PGF5 error message will be given. So wait for 250ms before sending a running command.
3. EMC-PG02U has encoder disconnection detection function.

#### 8-9-1 Terminal descriptions

Set by Pr.10-00-10-02, Pr.10-16-10-18

Terminals		Descriptions
PG1	VP	Output voltage for power: +5V/+12V±5% (use FSW3 to switch +5V/+12V) Max. output current: 200mA
	DCM	Common for power and signal
	A1, /A1, B1, /B1, Z1, /Z1	Encoder input signal (Line Driver) It can be 1-phase or 2-phase input. Max. output frequency: 300kHz
	U1, /U1, V1, /V1, W1, /W1	Encoder input signal
PG2	A2, /A2, B2, /B2	Pulse Input signal (Line Driver or Open Collector) Open Collector Input Voltage: +5~+24V (Note1) It can be 1-phase or 2-phase input. Max. output frequency: 300kHz.
PG OUT	AO, /AO, BO, /BO, ZO, /ZO, SG	PG Card Output signals. It has division frequency function: 1-255 times Max. output voltage for Line driver: 5V <sub>DC</sub> Max. output current: 15mA Max. output frequency: 300kHz SG is the GND of PG card. It is also the GND of position machine or PLC to make the output signal to be the common pivot point.

Note 1: Open Collector application, input current 5-15mA to each set then each set needs one pull-up resistor.

5V	Recommended pull-up resistor: above 100-220Ω, 1/2W
12V	Recommended pull-up resistor: above 510Ω-1.35kΩ, 1/2W
24V	Recommended pull-up resistor: above 1.8k-3.3kΩ, 1/2W

#### PG2 Wiring Diagram

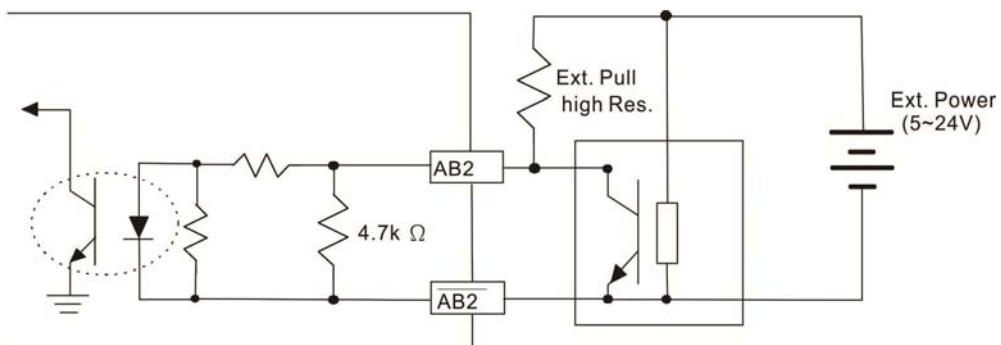

### 8-9-2 EMC-PG01U / EMC-PG02U Wiring Diagram

- ☑ Please use a shielded cable to prevent interference. Do not run control wires parallel to any high voltage AC power line (200 V<sub>AC</sub> and above).
- ☑ Recommended wire size 0.21–0.81mm<sup>2</sup> [AWG24–AWG18].
- ☑ Cable length: Single-phase input, less than 30m/ 2-phase input, less than 100m

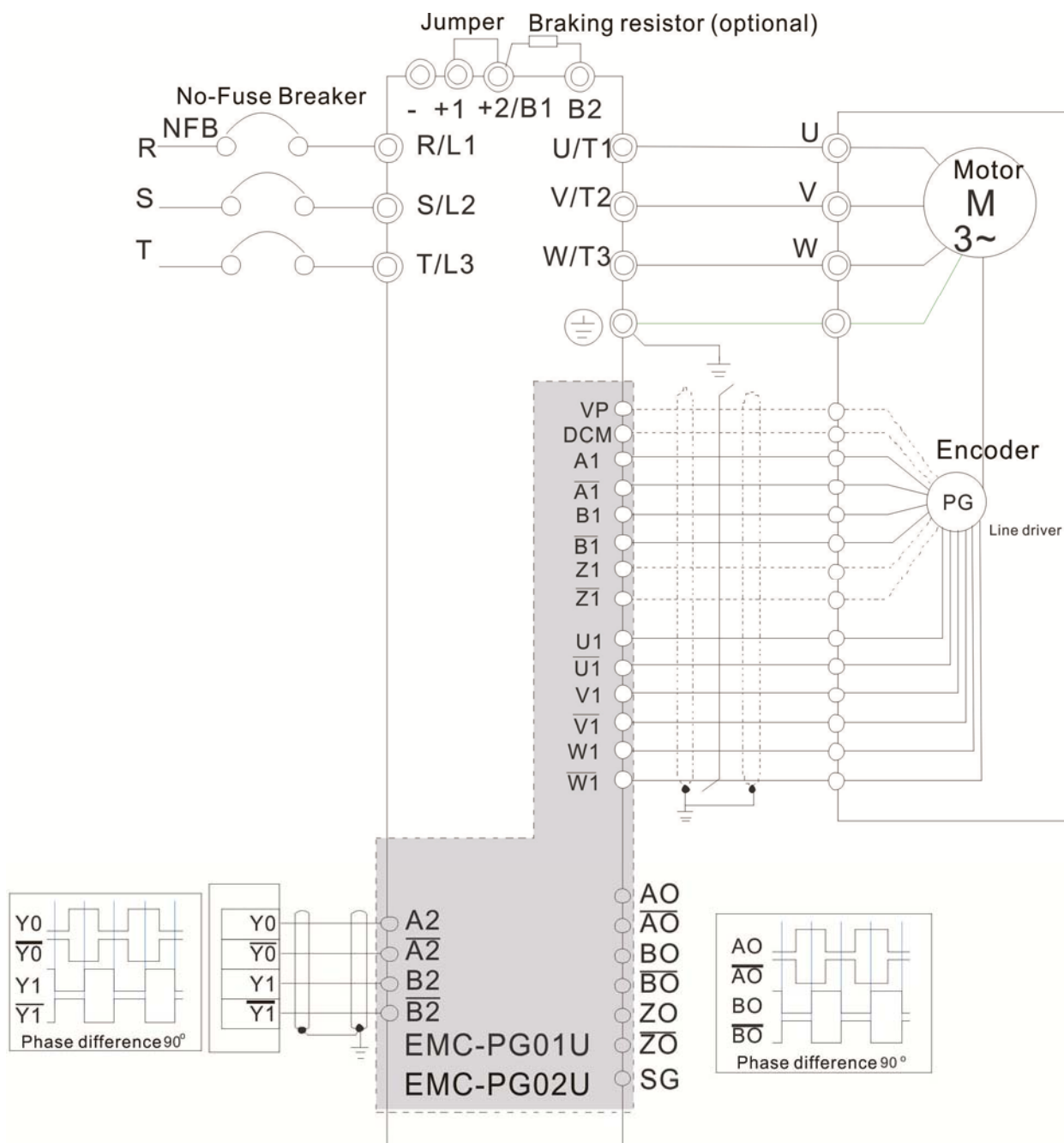

## 8-10 EMC-PG01R -- PG card (Resolver)

### 8-10-1 Terminal Descriptions

Set by Pr.10-00–10-02 and Pr.10-30 Resolver. (Pr.10-00=3, Pr.10-01=1024)

Terminals		Descriptions
PG1	R1- R2	Resolver Output Power 7Vrms, 10kHz
	S1, /S3, S2, /S4,	Resolver Input Signal (S2, /S4=Sin; S1, /S3=Cos) 3.5±0.175Vrms, 10kHz
PG2	A2, /A2, B2, /B2	Pulse Input signal (Line Driver or Open Collector) Open Collector Input Voltage: +5–+24V (Note1) It can be 1-phase or 2-phase input. Max. output frequency: 300kHz
PG OUT	AO, /AO, BO, /BO, ZO, /ZO, SG,	PG Card Output signals. It has division frequency function: 1–255 times Max. output voltage for Line driver: 5V <sub>DC</sub> Max. output current: 15mA Max. output frequency: 300kHz SG is the GND of PG card. It is also the GND of position machine or PLC to make the output signal to be the common pivot point.

Note 1: Open Collector application, input current 5–15mA to each set then each set needs one pull-up resistor.

5V	Recommended pull-up resistor: above 100–220Ω, 1/2W
12V	Recommended pull-up resistor: above 510Ω–1.35kΩ, 1/2W
24V	Recommended pull-up resistor: above 1.8k–3.3kΩ, 1/2W

#### PG2 Wiring Diagram

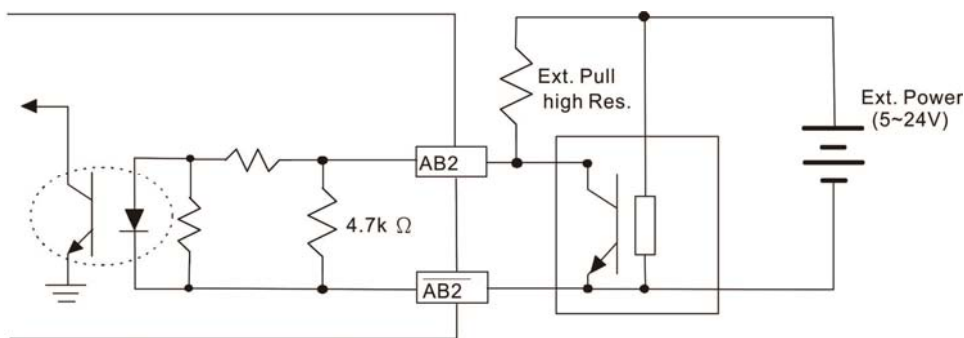

- 📖 **DOS (Degradation of Signal)** : If the amplitude of the sine wave input of the S1-/S3/ S2-/S4 is lower than or higher than the encoder IC's specification, a red light will be on. The possible reasons which cause this problem are the following.
  1. The turns ratio of the resolver encoder is not 1:0.5 which makes the sine wave input of the S1-/S3/S2-/S4 not equal to 3.5±0.175Vrms.
  2. While motor is running, motor creates common mode noise which makes accumulated voltage to be more than 3.5±0.175Vrms
- 📖 **LOT (Loss of Tracking)**: Compare the angle of S1-/S3/S2-/S4 sine wave input to the R1-R2 cosine wave. If their difference is more than 5 degree, a red light will be on. Here are the possible reasons why that happens:
  1. The output frequency of the PG card is incorrect.
  2. The specification of Resolver's encoder is not 10kHz
  3. The motor creates common mode noise while it is running. That causes a big difference, while the motor is rotating, between main winding's cosine wave angle and the sine wave angle of second and third windings.

### 8-10-2 EMC-PG01R Wiring Diagram

- ☑ Please use a shielded cable to prevent interference. Do not run control wires parallel to any high voltage AC power line (200 V<sub>AC</sub> and above).
- ☑ Recommended wire size 0.21–0.81mm<sup>2</sup> [AWG24–AWG18].
- ☑ Cable length: PG1 input, less than 30m; PG2 single-phase input, less than 30m/ 2-phase input, less than 100m

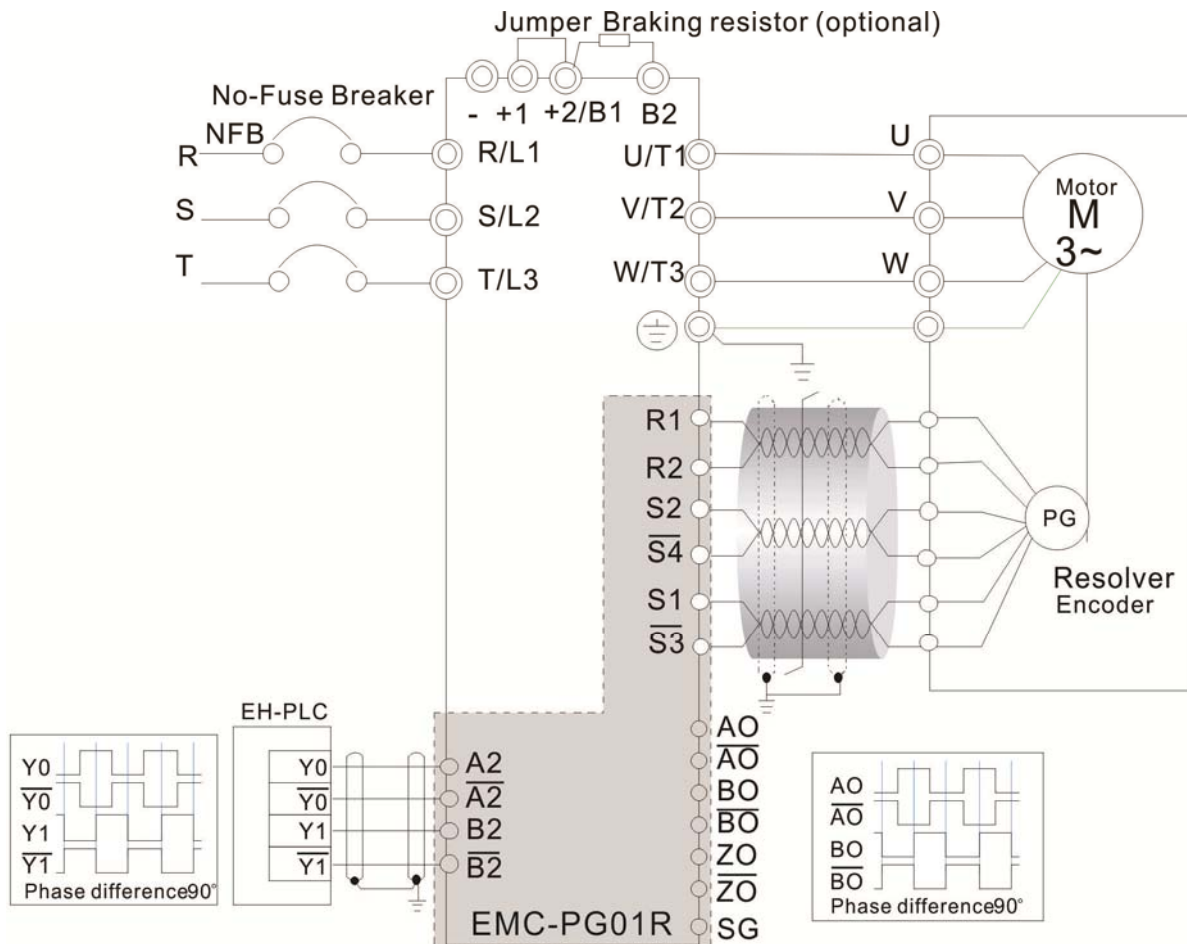

## 8-11 CMC-MOD01 -- Communication card, Modbus TCP

### 8-11-1 Features

1. Supports Modbus TCP protocol
2. MDI/MDI-X auto-detect
3. Baud rate: 10/100Mbps auto-detect
4. E-mail alarm
5. AC motor drive keypad/ Ethernet configuration
6. Virtual serial port.

### 8-11-2 Product File

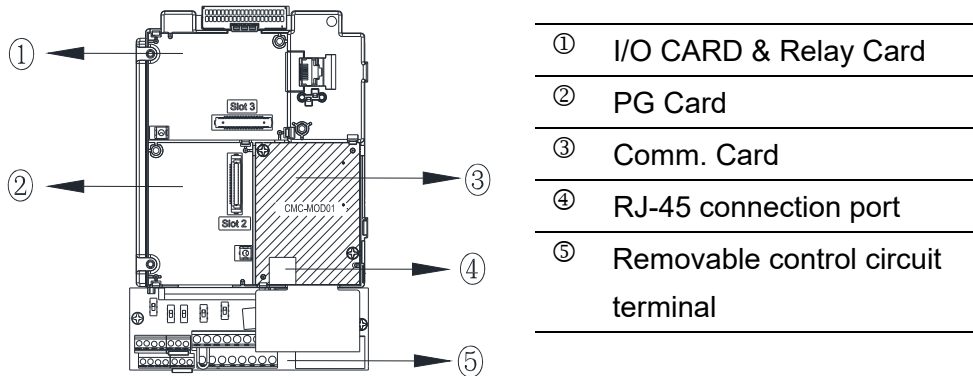

### 8-11-3 Specifications

#### Network Interface

Interface	RJ-45 with Auto MDI/MDIX
Number of ports	1 Port
Transmission method	IEEE 802.3, IEEE 802.3u
Transmission cable	Category 5e shielding 100M
Transmission speed	10/100 Mbps Auto-Detect
Network protocol	ICMP, IP, TCP, UDP, DHCP, HTTP, SMTP, MODBUS OVER TCP/IP, Delta Configuration

#### Electrical Specification

Power supply voltage	5V <sub>DC</sub> (supply by the AC motor drive)
Insulation voltage	500V <sub>DC</sub>
Power consumption	0.8W
Weight	25g



## Environment

Noise immunity	ESD (IEC 61800-5-1, IEC 61000-4-2) EFT (IEC 61800-5-1, IEC 61000-4-4) Surge Test (IEC 61800-5-1, IEC 61000-4-5) Conducted Susceptibility Test (IEC 61800-5-1, IEC 61000-4-6)
Operation/ storage	Operation: -10°C–50°C (temperature), 90% (humidity) Storage: -25°C –70°C (temperature), 95% (humidity)
Vibration/ shock immunity	International standard: IEC 61800-5-1, IEC 60068-2-6/ IEC 61800-5-1, IEC 60068-2-27

## 8-11-4 Communication Parameters for VFD-C2000 Connected to Ethernet

When VFD-C2000 is linked to Ethernet, please set up the communication parameters based on the table below. Ethernet master will be able to read/write the frequency word and control word of VFD-C2000 after communication parameters setup.

Parameter	Function	Set value (Dec)	Explanation
Pr. 00-20	Source of frequency command setting	8	The frequency command is controlled by communication card.
Pr. 00-21	Source of operation command setting	5	The operation command is controlled by communication card.
Pr. 09-30	Decoding method for communication	0	Decoding method for Delta AC motor drive
Pr. 09-75	IP setting	0	Static IP(0) / Dynamic distribution IP(1)
Pr. 09-76	IP address -1	192	IP address 192.168.1.5
Pr. 09-77	IP address -2	168	IP address 192.168.1.5
Pr. 09-78	IP address -3	1	IP address 192.168.1.5
Pr. 09-79	IP address -4	5	IP address 192.168.1.5
Pr. 09-80	Netmask -1	255	Netmask 255.255.255.0
Pr. 09-81	Netmask -2	255	Netmask 255.255.255.0
Pr. 09-82	Netmask -3	255	Netmask 255.255.255.0
Pr. 09-83	Netmask -4	0	Netmask 255.255.255.0
Pr. 09-84	Default gateway -1	192	Default gateway 192.168.1.1
Pr. 09-85	Default gateway -2	168	Default gateway 192.168.1.1
Pr. 09-86	Default gateway -3	1	Default gateway 192.168.1.1
Pr. 09-87	Default gateway -4	1	Default gateway 192.168.1.1

## 8-11-5 Basic Registers

BR#	R/W	Content	Explanation
#0	R	Model name	Set up by the system; read only. The model code of CMC-MOD01=H'0203
#1	R	Firmware version	Displaying the current firmware version in hex, e.g. H'0100 indicates the firmware version V1.00.
#2	R	Release date of the version	Displaying the data in decimal form. 10,000s digit and 1,000s digit are for "month"; 100s digit and 10s digit are for "day". For 1 digit: 0 = morning; 1 = afternoon.
#11	R/W	Modbus Timeout	Pre-defined setting: 500 (ms)
#13	R/W	Keep Alive Time	Pre-defined setting: 30 (s)



## 8-11-6 LED Indicator &amp; Troubleshooting

## LED Indicators

LED	Status	Indication	How to correct it?	
POWER	Green	On	Power supply in normal status	--
		Off	No power supply	Check the power supply
LINK	Green	On	Network connection in normal status	--
		Flashes	Network in operation	--
		Off	Network not connected	Check if the network cable is connected

## Troubleshooting

Abnormality	Cause	How to correct it?
POWER LED off	AC motor drive not powered	Check if AC motor drive is powered, and if the power supply is normal.
	CMC-MOD01 not connected to AC motor drive	Make sure CMC-MOD01 is connected to AC motor drive.
LINK LED off	CMC-MOD01 not connected to network	Make sure the network cable is correctly connected to network.
	Poor contact to RJ-45 connector	Make sure RJ-45 connector is connected to Ethernet port.
No module found	CMC-MOD01 not connected to network	Make sure CMC-MOD01 is connected to network.
	PC and CMC-MOD01 in different networks and blocked by network firewall.	Search by IP or set up relevant settings by AC motor drive keypad.
Fail to open CMC-MOD01 setup page	CMC-MOD01 not connected to network	Make sure CMC-MOD01 is connected to the network.
	Incorrect communication setting in DCISoft	Make sure the communication setting in DCISoft is set to Ethernet.
	PC and CMC-MOD01 in different networks and blocked by network firewall.	Conduct the setup by AC motor drive keypad.
Able to open CMC-MOD01 setup page but fail to utilize webpage monitoring	Incorrect network setting in CMC-MOD01	Check if the network setting for CMC-MOD01 is correct. For the Intranet setting in your company, please consult your IT staff. For the Internet setting in your home, please refer to the network setting instruction provided by your ISP.
Fail to send e-mail	Incorrect network setting in CMC-MOD01	Check if the network setting for CMC-MOD01 is correct.
	Incorrect mail server setting	Please confirm the IP address for SMTP-Server.

## 8-12 CMC-PD01 -- Communication card, PROFIBUS DP

### 8-12-1 Features

1. Supports PZD control data exchange.
2. Supports PKW polling AC motor drive parameters.
3. Supports user diagnosis function.
4. Auto-detects baud rates; supports Max. 12Mbps.

### 8-12-2 Product Profile

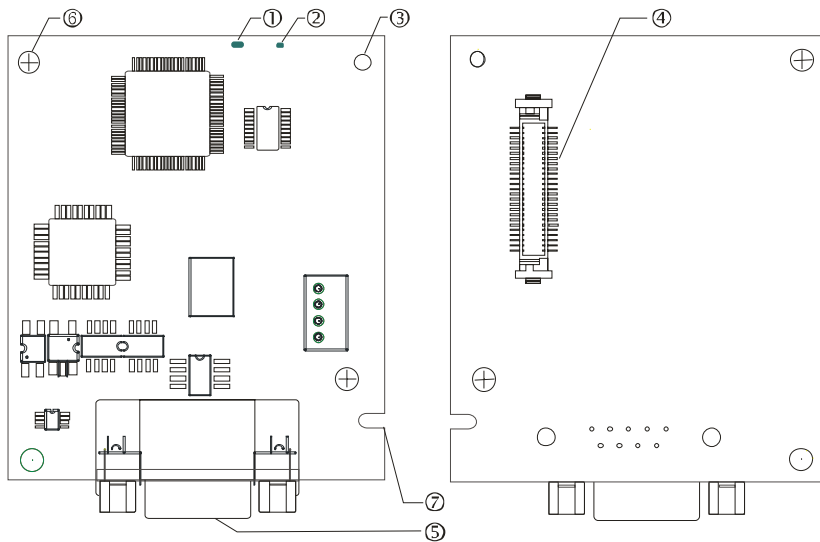

1. NET indicator
2. POWER indicator
3. Positioning hole
4. AC motor drive connection port
5. PROFIBUS DP connection port
6. Screw fixing hole
7. Fool-proof groove

### 8-12-3 Specifications

#### PROFIBUS DP Connector

Interface	DB9 connector
Transmission method	High-speed RS-485
Transmission cable	Shielded twisted pair cable
Electrical isolation	500V <sub>DC</sub>

#### Communication

Message type	Cyclic data exchange
Module name	CMC-PD01
GSD document	DELA08DB.GSD
Company ID	08DB (HEX)
Serial transmission speed supported (auto-detection)	9.6Kbps; 19.2Kbps; 93.75Kbps; 187.5Kbps; 500Kbps; 1.5Mbps; 3Mbps; 6Mbps; 12Mbps (bit per second)

#### Electrical Specification

Power supply	5V <sub>DC</sub> (supplied by AC motor drive)
Insulation voltage	500V <sub>DC</sub>
Power consumption	1W
Weight	28g

Environment

Noise immunity	ESD(IEC 61800-5-1, IEC 61000-4-2) EFT(IEC 61800-5-1, IEC 61000-4-4) Surge Teat(IEC 61800-5-1, IEC 61000-4-5) Conducted Susceptibility Test(IEC 61800-5-1, IEC 61000-4-6)
Operation /storage	Operation: -10°C–50°C (temperature), 90% (humidity) Storage: -25°C–70°C (temperature), 95% (humidity)
Shock / vibration resistance	International standards: IEC61131-2, IEC60068-2-6 (TEST Fc) / IEC61131-2 & IEC 60068-2-27 (TEST Ea)

8-12-4 Installation

PROFIBUS DP Connector

PIN	PIN name	Definition
1	-	Not defined
2	-	Not defined
3	Rxd/Txd-P	Sending / receiving data P(B)
4	-	Not defined
5	DGND	Data reference ground
6	VP	Power voltage – positive
7	-	Not defined
8	Rxd/Txd-N	Sending/receiving data N(A)
9	-	Not defined

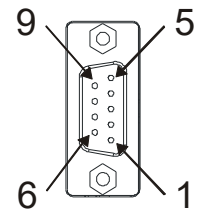

8-12-5 LED Indicator & Troubleshooting

There are 2 LED indicators on CMC-PD01: POWER LED and NET LED. POWER LED displays the status of the working power. NET LED displays the connection status of the communication.

POWER LED

LED status	Indication	How to correct it?
Green light on	Power supply in normal status.	--
Off	No power	Check if the connection between CMC-PD01 and AC motor drive is normal.

NET LED

LED status	Indication	How to correct it?
Green light on	Normal status	--
Red light on	CMC-PD01 is not connected to PROFIBUS DP bus.	Connect CMC-PD01 to PROFIBUS DP bus.
Red light flashes	Invalid PROFIBUS communication address	Set the PROFIBUS address of CMC-PD01 between 1 – 125 (decimal)
Orange light flashes	CMC-PD01 fails to communication with AC motor drive.	Switch off the power and check whether CMC-PD01 is correctly and normally connected to AC motor drive.

## 8-13 CMC-DN01 -- Communication card, DeviceNet

### 8-13-1 Functions

1. Based on the high-speed communication interface of Delta HSSP protocol, able to conduct immediate control to AC motor drive.
2. Supports Group 2 only connection and polling I/O data exchange.
3. For I/O mapping, supports Max. 32 words of input and 32 words of output.
4. Supports EDS file configuration in DeviceNet configuration software.
5. Supports all baud rates on DeviceNet bus: 125Kbps, 250Kbps, 500Kbps and extendable serial transmission speed mode.
6. Node address and serial transmission speed can be set up on AC motor drive.
7. Power supplied from AC motor drive.

### 8-13-2 Product Profile

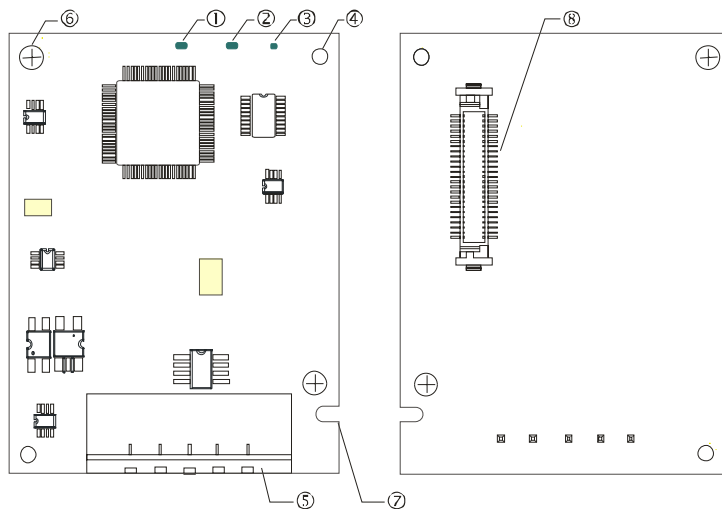

1. NS indicator
2. MS indicator
3. POWER indicator
4. Positioning hole
5. DeviceNet connection port
6. Screw fixing hole
7. Fool-proof groove
8. AC motor drive connection port

### 8-13-3 Specifications

#### DeviceNet Connector

Interface	5-PIN open removable connector of 5.08mm PIN interval
Transmission	CAN
Transmission cable	Shielded twisted pair cable (with 2 power cables)
Transmission speed	125Kbps, 250Kbps, 500Kbps and extendable serial transmission speed
Network protocol	DeviceNet protocol

#### AC Motor Drive Connection Port

Interface	50 PIN communication terminal
Transmission method	SPI communication
Terminal function	1. Communicating with AC motor drive 2. Transmitting power supply from AC motor drive
Communication	Delta HSSP protocol

Electrical Specification

Power supply voltage	5V <sub>DC</sub> (supplied by AC motor drive)
Insulation voltage	500V <sub>DC</sub>
Communication wire power consumption	0.85W
Power consumption	1W
Weight	23g

Environment

Noise immunity	ESD (IEC 61800-5-1, IEC 61000-4-2) EFT (IEC 61800-5-1, IEC 61000-4-4) Surge Teat(IEC 61800-5-1, IEC 61000-4-5) Conducted Susceptibility Test (IEC 61800-5-1, IEC 61000-4-6)
Operation /storage	Operation: -10°C –50°C (temperature), 90% (humidity) Storage: -25°C–70°C (temperature), 95% (humidity)
Shock / vibration resistance	International standards: IEC61800-5-1, IEC60068-2-6 (TEST Fc) / IEC61800-5-1 & IEC60068-2-27 (TEST Ea)

8-13-4 Installation

DeviceNet Connector

PIN	Signal	Color	Definition
1	V+	Red	DC24V
2	H	White	Signal+
3	S	-	Earth
4	L	Blue	Signal-
5	V-	Black	0V

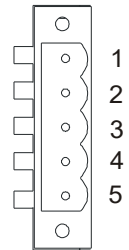

8-13-5 LED Indicator & Troubleshooting

There are 3 LED indicators on CMC-DN01. POWER LED displays the status of power supply. MS LED and NS LED are dual-color LED, displaying the connection status of the communication and error messages.

POWER LED

LED status	Indication	How to correct it?
Off	Power supply in abnormal status.	Check the power supply of CMC-DN01.
Green light On	Power supply in normal status	--

## NS LED

LED status	Indication	How to correct it?
Off	No power supply or CMC-DN01 has not completed MAC ID test yet.	<ol style="list-style-type: none"> <li>1. Check the power of CMC-DN01 and see if the connection is normal.</li> <li>2. Make sure at least one or more nodes are on the bus.</li> <li>3. Check if the serial transmission speed of CMC-DN01 is the same as that of other nodes.</li> </ol>
Green light flashes	CMC-DN01 is on-line but has not established connection to the master.	<ol style="list-style-type: none"> <li>1. Configure CMC-DN01 to the scan list of the master.</li> <li>2. Re-download the configured data to the master.</li> </ol>
Green light on	CMC-DN01 is on-line and is normally connected to the master	--
Red light flashes	CMC-DN01 is on-line, but I/O connection is timed-out.	<ol style="list-style-type: none"> <li>1. Check if the network connection is normal.</li> <li>2. Check if the master operates normally.</li> </ol>
Red light on	<ol style="list-style-type: none"> <li>1. The communication is down.</li> <li>2. MAC ID test failure.</li> <li>3. No network power supply.</li> <li>4. CMC-DN01 is off-line.</li> </ol>	<ol style="list-style-type: none"> <li>1. Make sure all the MAC IDs on the network are not repeated.</li> <li>2. Check if the network installation is normal.</li> <li>3. Check if the baud rate of CMC-DN01 is consistent with that of other nodes.</li> <li>4. Check if the node address of CMC-DN01 is illegal.</li> <li>5. Check if the network power supply is normal.</li> </ol>

## MS LED

LED status	Indication	How to correct it?
Off	No power supply or being off-line	Check the power supply of CMC-DN01 and see if the connection is normal.
Green light flashes	Waiting for I/O data	Switch the master PLC to RUN status
Green light on	I/O data are normal	--
Red light flashes	Mapping error	<ol style="list-style-type: none"> <li>1. Reconfigure CMC-DN01</li> <li>2. Re-power AC motor drive</li> </ol>
Red light on	Hardware error	<ol style="list-style-type: none"> <li>1. See the error code displayed on AC motor drive.</li> <li>2. Send back to the factory for repair if necessary.</li> </ol>
Orange light flashes	CMC-DN01 is establishing connection with AC motor drive.	If the flashing lasts for a long time, turn off the power and check if CMC-DN01 and AC motor drive are correctly installed and normally connected to each other.

## 8-14 CMC-EIP01 -- Communication card, EtherNet/IP

### 8-14-1 Features

1. Supports Modbus TCP and Ethernet/IP protocol
2. Supports all parameters read/write (use with EIP V.1.06)
3. MDI/MDI-X auto-detect
4. Baud rate: 10/100Mbps auto-detect
5. AC motor drive keypad/ Ethernet configuration
6. Virtual serial port

### 8-14-2 Product Profile

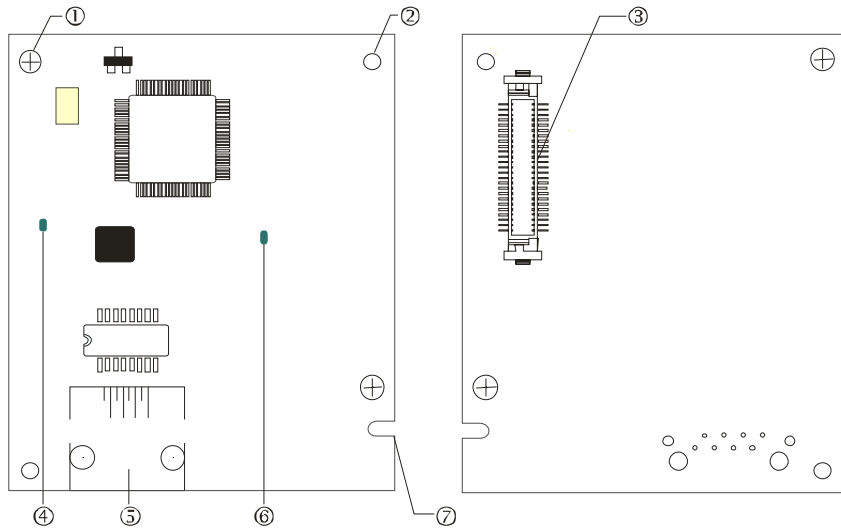

[Figure1]

1. Screw fixing hole
2. Positioning hole
3. AC motor drive connection port
4. LINK indicator
5. RJ-45 connection port
6. POWER indicator
7. Alignment groove

### 8-14-3 Specifications

#### Network Interface

Interface	RJ-45 with Auto MDI/MDIX
Number of ports	1 Port
Transmission method	IEEE 802.3, IEEE 802.3u
Transmission cable	Category 5e shielding 100M
Transmission speed	10/100 Mbps Auto-Detect
Network protocol	ICMP, IP, TCP, UDP, DHCP, HTTP, SMTP, MODBUS over TCP/IP, EtherNet/IP, Delta Configuration

#### Electrical Specification

Weight	25g
Insulation voltage	500V <sub>DC</sub>
Power consumption	0.8W
Power supply voltage	5V <sub>DC</sub> (provided by VFD-C2000)

## Environment

Noise immunity	ESD (IEC 61800-5-1, IEC 61000-4-2) EFT (IEC 61800-5-1, IEC 61000-4-4) Surge Test (IEC 61800-5-1, IEC 61000-4-5) Conducted Susceptibility Test (IEC 61800-5-1, IEC 61000-4-6)
Operation/storage	Operation: -10°C–50°C (temperature), 90% (humidity) Storage: -25°C–70°C (temperature), 95% (humidity)
Vibration/shock immunity	International standards: IEC 61800-5-1, IEC 60068-2-6/IEC 61800-5-1, IEC 60068-2-27

## 8-14-4 Installation

## Connecting CMC-EIP01 to Network

1. Turn off power to the AC motor drive.
2. Open the cover of the AC motor drive.
3. Connect a CAT-5e network cable to the RJ-45 port on the CMC-EIP01 (See Figure 2).

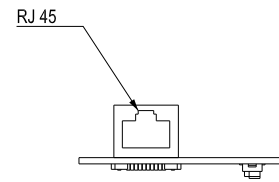

[Figure 2]

## RJ-45 PIN Definition

PIN	Signal	Definition	PIN	Signal	Definition
1	Tx+	Positive pole for data transmission	5	--	N/C
2	Tx-	Negative pole for data transmission	6	Rx-	Negative pole for data receiving
3	Rx+	Positive pole for data receiving	7	--	N/C
4	--	N/C	8	--	N/C

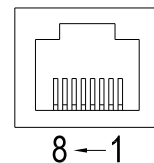

## 8-14-5 Communication Parameters for VFD-C2000 Connected to Ethernet

When the VFD-C2000 is connected to an Ethernet network, please set up the communication parameters for it according to the table below. The Ethernet master is only able to read/write the frequency word and control word of VFD-C2000 after the communication parameters are set.

Parameter	Function	Set value (Dec)	Explanation
Pr. 00-20	Source of frequency command setting	8	The frequency command is controlled by communication card.
Pr. 00-21	Source of operation command setting	5	The operation command is controlled by communication card.
Pr. 09-30	Decoding method for communication	0	The decoding method for Delta AC motor drive
Pr. 09-75	IP setting	0	Static IP(0) / Dynamic distribution IP(1)
Pr. 09-76	IP address -1	192	IP address 192.168.1.5
Pr. 09-77	IP address -2	168	IP address 192.168.1.5
Pr. 09-78	IP address -3	1	IP address 192.168.1.5
Pr. 09-79	IP address -4	5	IP address 192.168.1.5



Parameter	Function	Set value (Dec)	Explanation
Pr. 09-80	Netmask -1	255	Netmask 255.255.255.0
Pr. 09-81	Netmask -2	255	Netmask 255.255.255.0
Pr. 09-82	Netmask -3	255	Netmask 255.255.255.0
Pr. 09-83	Netmask -4	0	Netmask 255.255.255.0
Pr. 09-84	Default gateway -1	192	Default gateway 192.168.1.1
Pr. 09-85	Default gateway -2	168	Default gateway 192.168.1.1
Pr. 09-86	Default gateway -3	1	Default gateway 192.168.1.1
Pr. 09-87	Default gateway -4	1	Default gateway 192.168.1.1

### 8-14-6 LED Indicator & Troubleshooting

There are 2 LED indicators on the CMC-EIP01. The POWER LED displays the status of power supply, and the LINK LED displays the connection status of the communication.

#### LED Indicators

LED	Status	Indication	How to correct it?	
POWER	Green	On	Power supply in normal status	--
		Off	No power supply	Check the power supply.
LINK	Green	On	Network connection in normal status	--
		Flashing	Network in operation	--
		Off	Network not connected	Check if the network cable is connected.

#### Troubleshooting

Abnormality	Cause	How to correct it?
POWER LED off	AC motor drive not powered	Check if AC motor drive is powered, and if the power supply is normal.
	CMC-EIP01 not connected to AC motor drive	Make sure CMC-EIP01 is connected to AC motor drive.
LINK LED off	CMC-EIP01 not connected to network	Make sure the network cable is correctly connected to network.
	Poor contact to RJ-45 connector	Make sure RJ-45 connector is connected to Ethernet port.
No communication card found	CMC-EIP01 not connected to network	Make sure CMC-EIP01 is connected to network.
	PC and CMC-EIP01 in different networks and blocked by network firewall.	Search by IP or set up relevant settings by AC motor drive keypad.
Fail to open CMC-EIP01 setup page	CMC-EIP01 not connected to network	Make sure CMC-EIP01 is connected to the network.
	Incorrect communication setting in DCISoft	Make sure the communication setting in DCISoft is set to Ethernet.
	PC and CMC-EIP01 in different networks and blocked by network firewall.	Conduct the setup by AC motor drive keypad.

Abnormality	Cause	How to correct it?
Able to open CMC-EIP01 setup page but fail to utilize webpage monitoring	Incorrect network setting in CMC-EIP01	Check if the network setting for CMC-EIP01 is correct. For the Intranet setting in your company, please consult your IT staff. For the Internet setting in your home, please refer to the network setting instruction provided by your ISP.
Fail to send e-mail	Incorrect network setting in CMC-EIP01	Check if the network setting for CMC-EIP01 is correct.
	Incorrect mail server setting	Please confirm the IP address for SMTP-Server.

## 8-15 CMC-EC01 -- Communication card, EtherCAT

### 8-15-1 Features

The EtherCAT of C2000 currently provides standard control mode of CiA402 Velocity (Index 6060=2), but it is non-synchronous control mode. There is no need to turn on the DC (Distribute Clock) function when operating. However, if the DC function is required for using with synchronous products (e.g. ASDA-A2), the CMC-EC01 can still be used normally under this circumstances. The VFD-C2000 supports the EtherCAT function with firmware version 2.02 and above. Please be attention to the firmware you use.

### 8-15-2 Product Profile

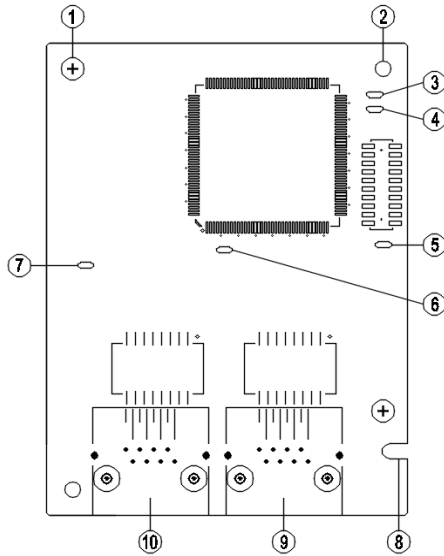

[Figure 1]

1. Screw fixing hole
2. Positioning hole
3. RUN indicator
4. ERR indicator
5. POWER indicator
6. OUT LINK indicator
7. IN LINK indicator
8. Fool-proof groove
9. RJ-45 connection port
10. RJ-45 connection port
11. Control board connection port

### 8-15-3 Specifications

#### Network Interface

Interface	RJ-45
Number of ports	2 Port
Transmission method	IEEE802.3, IEEE802.3u
Transmission cable	Category 5e shielding 100 M
Transmission speed	10 / 100 Mbps Auto-Defect
Network protocol	EtherCAT

#### Electrical Specification

Power supply voltage	5V <sub>DC</sub>
Power consumption	0.8W
Insulation voltage	500V <sub>DC</sub>
Weight (g)	27

## Environment

Noise immunity	ESD (IEC 61800-5-1, IEC 61000-4-2) EFT (IEC 61800-5-1, IEC 61000-4-4) Surge Test (IEC 61800-5-1, IEC 61000-4-5) Conducted Susceptibility Test (IEC 61800-5-1, IEC 61000-4-6)
Operation	-10°C–15°C (temperature), 90% (humidity)
Storage	-25°C–70°C (temperature), 95% (humidity)
Vibration / shock immunity	International standard: IEC 61800-5-1, IEC 60068-2-6 / IEC 61800-5-1, IEC 60068-2-27

## 8-15-4 RJ-45 PIN Definition

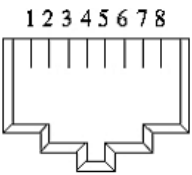
RJ-45	PIN No.	Signal	Definition
	1	Tx+	Positive pole for data transmission
	2	Tx-	Negative pole for data transmission
	3	Rx+	Positive pole for data receiving
	4	--	N / C
	5	--	N / C
	6	Rx-	Negative pole for data receiving
	7	--	N / C
	8	--	N / C

## 8-15-5 Communication Parameters for VFD-C2000 Connected to EtherCAT

When operating VFD-C2000 via CMC-EC01, please set the control and operation command as controlled by communication card. When C2000 is connected to EtherCAT network, please set up the communication parameters according to the table below.

Parameter	Set value (Dec)	Explanation
Pr. 00-20	8	The frequency command is controlled by communication card.
Pr. 00-21	5	The operation command is controlled by communication card.
Pr. 09-60	6	Identification: when CMC-EC01 is connected, Pr.09-60 will show value 6 (EtherCAT Slave)
Pr. 09-61	--	Version of communication card

## 8-15-6 LED Indicator

LED	Status		Indication
POWER	Green	On	Power supply in normal status
		Off	No power supply
LINK	Green	On	Operate in normal status
		Flashes	Pre-operation (On / Off 200ms)
			Operate in safe mode (On 200ms / Off 1000ms)
Off	Initial state		

LED	Status		Indication
ERROR	Red	Flashed	Basic configuration error (On / Off 200ms)
			Status switching error (On 200ms / Off 1000ms)
			Times out (On 200ms twice / Off 1000ms)
IN LINK	Green	On	Network connection in normal status
		Flashes	Network in operation
		Off	Network not connected
OUT LINK	Green	On	Network connection in normal status
		Flashes	Network in operation
		Off	Network not connected

### 8-15-7 Network Connection

Because the packet delivery of EtherCAT has directional characteristics, the connection must be correct. The designed delivery direction of CMC-EC01 is left for IN / right for ON, the correct wiring is as below shown:

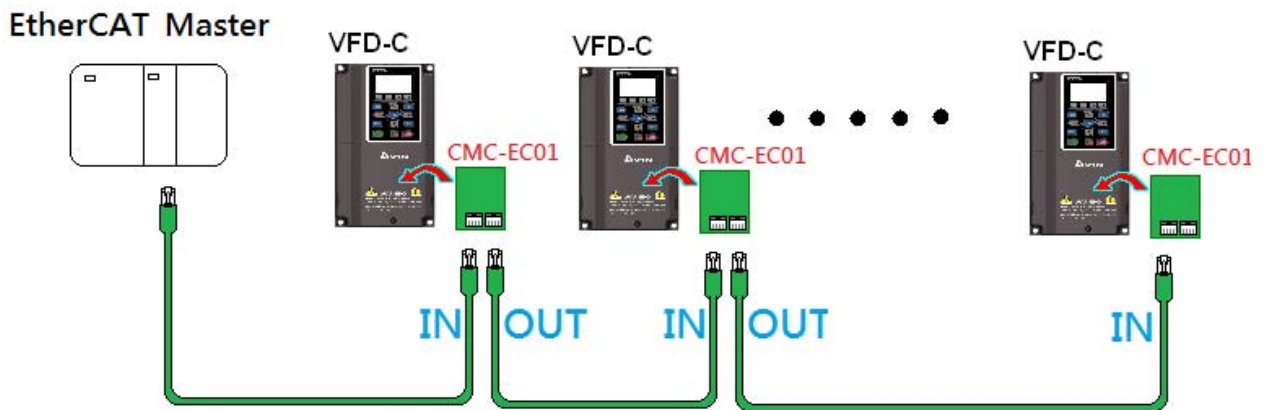

When the hardware is installed and power on, check for the display. The current set value of Pr.09-60 will be 6, and shows "EtherCAT" on the display. If the above information does not show on the display, please check the version of VFD-C2000 (V2.02 and above) and the connection of the card.

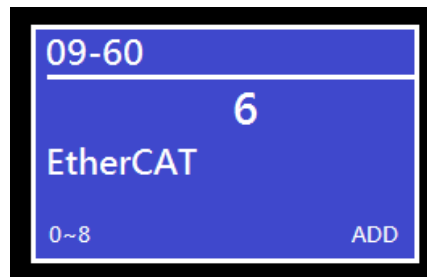

## 8-16 CMC-PN01 -- Communication card, PROFINET

### 8-16-1 Features

CMC-PN01 connects C2000 drive to PROFINET to exchange data with the host controller easily. This simple network solution saves cost and time for connection and installation of factory automation. Moreover, its components are compatible with suppliers'.

By installing CMC-PN01 in C2000 through the main PROFINET device, you can:

1. Control the drive through PROFINET
2. Modify the drive's parameters through PROFINET
3. Monitor the drive's status through PROFINET.

### 8-16-2 Product profile

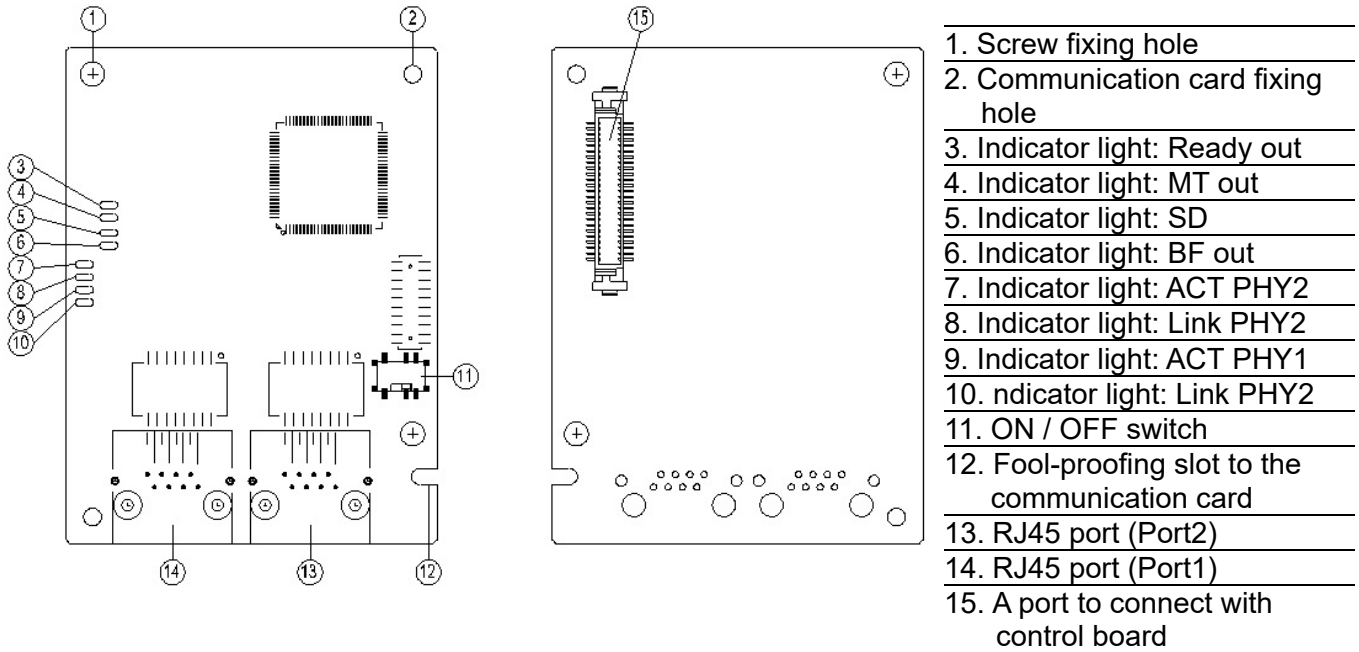

Label with MAC address

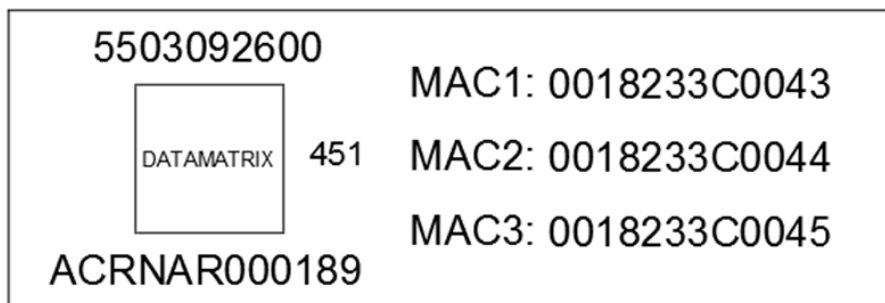

Definition	Description
MAC1	Port 1 MAC Address
MAC2	Port 2 MAC Address
MAC3	Interface MAC Address

## 8-16-3 Specifications

## Network interface

Item	Specifications
Interface	RJ45
Number of ports	2 ports
Transmission cable	IEEE 802.3
Transmission rate	Category 5e shielding 100 M
Communication protocol	10/100 Mbps auto-negotiate
Interface	PROFINET

## Electrical specification

Item	Specifications
Power supply voltage	5 V <sub>DC</sub>
Power consumption	0.8 W
Insulation voltage	500 V <sub>DC</sub>
Weight (g)	27 (g)

## Environmental conditions

Item	Specifications
Noise immunity	ESD (IEC 61800-5-1, IEC 6100-4-2) EFT (IEC 61800-5-1, IEC 6100-4-4) Surge Teat (IEC 61800-5-1, IEC 6100-4-5) Conducted Susceptibility Test (IEC 61800-5-1, IEC 6100-4-6)
Operation and storage	-10–50°C (temperature), 90% (humidity)
Vibration & shock resistance	International Standard: IEC 61800-5-1, IEC 60068-2-6 / IEC 61800-5-1, IEC 60068-2-27

## 8-16-4 Definition of PINs in RJ45 port

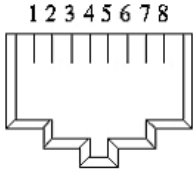
RJ45	PIN	Signal	Definition
	1	Tx+	Positive pole for data transmission
	2	Tx-	Negative pole for data transmission
	3	Rx+	Positive pole for receiving data
	4	--	N/C
	5	--	N/C
	6	Rx-	Negative pole for receiving data
	7	--	N/C
	8	--	N/C

### 8-16-5 To set the communication parameters when C2000 connects with PROFINET

When you operate VFD-C2000 through CMC-PN01, you should set the communication card as the source of VFD-C2000 controls and settings. You need to use the keypad to configure the following parameter addresses to the corresponding values:

Parameters	Setting value	Description
Pr.00-20	8	The frequency command is controlled by communication card
Pr.00-21	5	The frequency command is controlled by communication card
Pr.09-30	1	Use decoding method (60xx or 20xx)
Pr.09-60	12	Communication card identification: When CMC-PN01 communication card is connected, the value of this parameter displays "12".

### 8-16-6 LED indicator introduction

Name	Indicator status	Indication	
Ready out indicator	Yellow LED	Always on	PN Stack starts normally
		Flashing	PN Stack starts normally, and waiting for syncing with MCU
		Off	PN Stack failed to start
MT out indicator	Green LED	-	-
SD indicator	Red LED	-	-
BF out indicator	Red LED	Always on	Connection with PROFINET Controller is interrupted
		Flashing	Connection is in normal state, but the communication with PROFINET Controller is abnormally
		Off	Connection with PROFINET Controller is in normal state
ACT PHY1 indicator	Orange LED	Always on	It's online, and exchanging the data with Master normally
		Flashing	It's offline, but hand shaking the data with Master
		Off	Initial state
LINK PHY1 indicator	Green LED	Always on	Internet connection is in normal state
		Off	Doesn't connect to network
ACT PHY2 indicator	Orange LED	Always on	It's online, and exchanging the data with Master normally
		Flashing	It's offline, but hand shaking the data with Master
		Off	Initial state
LINK PHY2 indicator	Green LED	Always on	Internet connection is in normal state
		Off	Doesn't connect to network



### 8-16-7 Network connection

The wiring of CMC-PN01 shows as follows:

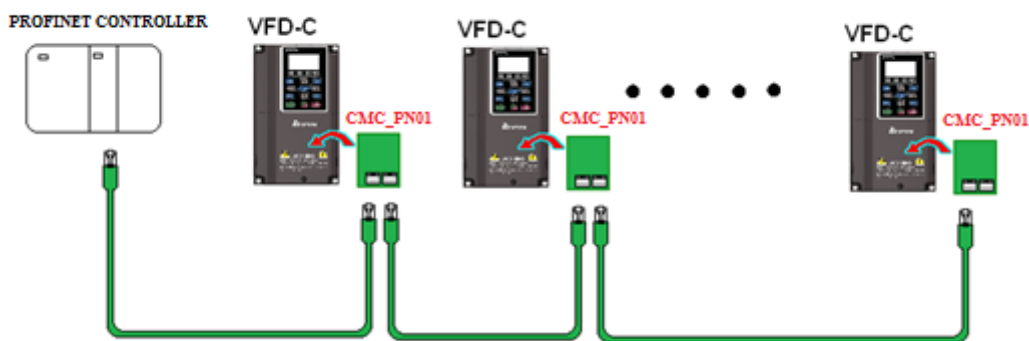

When the installation is finished, supply electricity to the drive. The Pr.09-60 of the drive should be able to display “PROFINET” with a current value of 12. If not, make sure your version of the drive is correct (C2000 needs 2.04 or later versions) and the communication card is correctly connected.

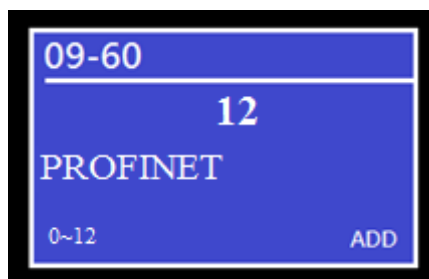

## 8-17 EMC-COP01 -- Communication card, CANopen

### 8-17-6 Terminating Resistor Position

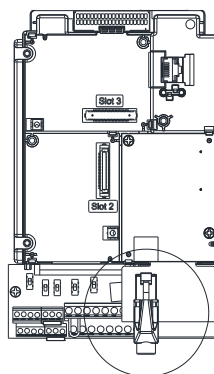
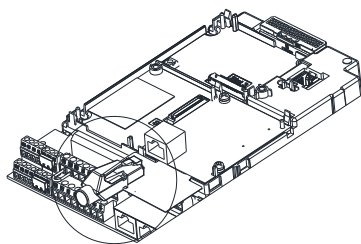

### 8-17-7 RJ-45 Pin Definition



RS485 socket

Pin	Pin name	Definition
1	CAN_H	CAN_H bus line (dominant high)
2	CAN_L	CAN_L bus line (dominant low)
3	CAN_GND	Ground/0V/V-
7	CAN_GND	Ground/0V/V-

### 8-17-8 Specifications

Interface	RJ-45
Number of ports	1 Port
Transmission method	CAN
Transmission cable	CAN standard cable
Transmission speed	1Mbps, 500Kbps, 250Kbps, 125Kbps, 100Kbps, 50Kbps
Communication protocol	CANopen

## 8-18 Delta Standard Fieldbus Cables

Delta Cables	Part Number	Description	Length
CANopen Cable	UC-CMC003-01A	CANopen cable, RJ45 connector	0.3m
	UC-CMC005-01A	CANopen cable, RJ45 connector	0.5m
	UC-CMC010-01A	CANopen cable, RJ45 connector	1m
	UC-CMC015-01A	CANopen cable, RJ45 connector	1.5m
	UC-CMC020-01A	CANopen cable, RJ45 connector	2m
	UC-CMC030-01A	CANopen cable, RJ45 connector	3m
	UC-CMC050-01A	CANopen cable, RJ45 connector	5m
	UC-CMC100-01A	CANopen cable, RJ45 connector	10m
	UC-CMC200-01A	CANopen cable, RJ45 connector	20m
DeviceNet Cable	UC-DN01Z-01A	DeviceNet cable	305m
	UC-DN01Z-02A	DeviceNet cable	305m
EtherNet / EtherCAT Cable	UC-EMC003-02A	Ethernet / EtherCAT cable, Shielding	0.3m
	UC-EMC005-02A	Ethernet / EtherCAT cable, Shielding	0.5m
	UC-EMC010-02A	Ethernet / EtherCAT cable, Shielding	1m
	UC-EMC020-02A	Ethernet / EtherCAT cable, Shielding	2m
	UC-EMC050-02A	Ethernet / EtherCAT cable, Shielding	5m
	UC-EMC100-02A	Ethernet / EtherCAT cable, Shielding	10m
	UC-EMC200-02A	Ethernet / EtherCAT cable, Shielding	20m
CANopen / DeviceNet TAP	TAP-CN01	1 in 2 out, built-in 121Ω terminal resistor	1 in 2 out
	TAP-CN02	1 in 4 out, built-in 121Ω terminal resistor	1 in 4 out
	TAP-CN03	1 in 4 out, RJ45 connector, built-in 121Ω terminal resistor	1 in 4 out, RJ45
PROFIBUS Cable	UC-PF01Z-01A	PROFIBUS DP cable	305m

# ***Chapter 9 Specification***

---

9-1 230V Series

9-2 460V Series

9-3 575V Series

9-4 690V Series

9-5 Environment for Operation, Storage and Transportation

9-6 Specification for Operation Temperature and Protection Level

9-7 Derating Curve of Ambient Temperature

9-8 Efficiency Curve

### 9-1 230V Series

Frame Size		A				B			C			D		E			F		
Model VFD-__C__		007	015	022	037	055	075	110	150	185	220	300	370	450	550	750	900		
*Output Rating	Normal Duty	Rated Output Capacity [kVA]	2.0	3.2	4.4	6.8	10	13	20	26	30	36	48	58	72	86	102	138	
		Rated Output Current [A]	5	8	11	17	25	33	49	65	75	90	120	146	180	215	255	346	
		Applicable Motor Output [kW]	0.75	1.5	2.2	3.7	5.5	7.5	11	15	18.5	22	30	37	45	55	75	90	
		Applicable Motor Output [HP]	1	2	3	5	7.5	10	15	20	25	30	40	50	60	75	100	120	
		Overload Capacity	120% of rated output current: 1 minute for every 5 minutes; 160% of rated output current: 3 seconds for every 30 seconds																
		Max. Output Frequency [Hz]	0.00~599.00																
	Heavy Duty	Carrier Frequency [kHz]	2~15 (Default: 8)						2~10 (Default: 6)			2~9 (Default: 4)							
		Rated Output Capacity [kVA]	1.9	2.8	4.0	6.4	9.6	12	19	25	28	34	45	55	68	81	96	131	
		Rated Output Current [A]	4.8	7.1	10	16	24	31	47	62	71	86	114	139	171	204	242	329	
		Applicable Motor Output [kW]	0.4	0.75	1.5	2.2	3.7	5.5	7.5	11	15	19	22	30	37	45	55	75	
		Applicable Motor Output [HP]	0.5	1	2	3	5	7.5	10	15	20	25	30	40	50	60	75	100	
		Overload Capacity	150% of rated output current: 1 minute for every 5 minutes; 180% of rated output current: 3 seconds for every 30 seconds																
	Rating Input	Input Current [A]	Normal Duty	6.4	12	16	20	28	36	52	72	83	99	124	143	171	206	245	331
			Heavy Duty	6.1	11	15	18.5	26	34	50	68	78	95	118	136	162	196	233	315
Rated Voltage / Frequency		3-phase AC 200V~240V (-15% ~ +10%) · 50 / 60Hz																	
Operating Voltage Range		170~264V <sub>AC</sub>																	
Frequency Tolerance		47~63Hz																	
Efficiency [%]	97.8												98.2						
Power Factor	>0.98																		
Drive Weight [Kg]	2.6 ± 0.3				5.4 ± 1			9.8 ± 1.5			38.5 ± 1.5		64.8 ± 1.5			86.5 ± 1.5			
Cooling Method	Natural cooling	Fan cooling																	
Braking Chopper	Frame A~C: Built-in											Frame D~F: Optional							
DC choke	Frame A~C: Optional											Frame D~F: Built-in							
EMC Filter	Frame A~F: Optional																		
EMC-COP01	Frame A~F: Optional																		

Table 9-1

 **NOTE**

- \* : The factory setting is Normal Duty mode.
- The carrier frequency is default. Increasing the carrier frequency requires a reduction in current. Please refer to Chapter 9-7 Derating Curve of Ambient Temperature.
- The AC motor drive should operate in derating current when its control method is set to FOC Sensorless, TQC+PG, TQC sensorless, PM+PG, PM sensorless Please refer to Pr. 06-55 for more information.
- Select the AC motor drive with capacity one grade larger for the impact load application.
- The rated input current will be affected by not only Power Transformer and the connection of the reactors on input side, but also fluctuates with the impedance of power side.
- For Frame D and above, if the last character of the model is A then it is under IP20 protection level but the wiring terminal is under IP00 protection level; if the last character of the model is E, it is under IP20/NEMA1/UL TYPE1 protection level.

## 9-2 460V Series

Frame Size		A					B			C				
Model VFD-___C__		007	015	022	037	040	055	075	110	150	185	220	300	
*Output Rating	Normal Duty	Rated Output Capacity [kVA]	2.4	3.2	4.8	7.2	8.4	10	14	19	25	30	36	48
		Rated Output Current [A]	3.0	4.0	6.0	9.0	10.5	12	18	24	32	38	45	60
		Applicable Motor Output [kW]	0.75	1.5	2.2	3.7	4.0	5.5	7.5	11	15	18.5	22	30
		Applicable Motor Output [HP]	1	2	3	5	5	7.5	10	15	20	25	30	40
		Overload Capacity	120% of rated output current: 1 minute for every 5 minutes; 160% of rated output current: 3 seconds for every 30 seconds											
		Max. Output Frequency [Hz]	0.00~599.00											
		Carrier Frequency [kHz]	2~15 (Default: 8)									2~10 (Default: 6)		
	Heavy Duty	Rated Output Capacity [kVA]	2.3	3.0	4.5	6.5	7.6	9.6	14	18	24	29	34	45
		Rated Output Current [A]	2.9	3.8	5.7	8.1	9.5	11	17	23	30	36	43	57
		Applicable Motor Output [kW]	0.4	0.75	1.5	2.2	3.7	4.0	5.5	7.5	11	15	18.5	22
		Applicable Motor Output [HP]	0.5	1	2	3	5	5	7.5	10	15	20	25	30
		Overload Capacity	150% of rated output current: 1 minute for every 5 minutes; 180% of rated output current: 3 seconds for every 30 seconds											
		Max. Output Frequency [Hz]	0.00~300.00											
		Carrier Frequency [kHz]	2~15 (Default: 2)									2~10 (Default: 2)		
Input Rating	Input Current [A]	Normal Duty	4.3	5.9	8.7	14	15.5	17	20	26	35	40	47	63
		Heavy Duty	4.1	5.6	8.3	13	14.5	16	19	25	33	38	45	60
	Rated Voltage / Frequency		3-phase AC 380V~480V ( -15%~+10%), 50 / 60Hz											
	Operating Voltage Range		323~528V <sub>AC</sub>											
Frequency Tolerance		47~63Hz												
Efficiency [%]		97.8												
Power Factor		>0.98												
Drive Weight [Kg]		2.6± 0.3					5.4± 1			9.8± 1.5				
Cooling Method		Natural cooling		Fan cooling										
Braking Chopper		Frame A~C: Built-in												
DC choke		Frame A~C: Optional												
EMC Filter		VFDXXC43A: Optional; Frame A~C VFDXXC43E: Built-in												
EMC-COP01		VFDXXC43A: Optional; VFDXXC43E: Built-in												

Table 9-2

 **NOTE**

- \* : The factory setting is Normal Duty mode.
- The carrier frequency is default. Increasing the carrier frequency requires a reduction in current. Please refer to Chapter 9-7 Derating Curve of Ambient Temperature.
- The AC motor drive should operate in derating current when its control method is set to FOC Sensorless, TQC+PG, TQC sensorless, PM+PG, PM sensorless. Please refer to Pr. 06-55 for more information.
- Select the AC motor drive with capacity one grade larger for the impact load application.
- The rated input current will be affected by not only Power Transformer and the connection of the reactors on input side, but also fluctuates with the impedance of power side.
- For Frame A, B and C, Model VFDXXC43A is under IP20/NEMA1/UL TYPE1 protection level.
- For Frame D and above, if the last character of the model is A then it is under IP20 protection level but the wiring terminal is under IP00 protection level; if the last character of the model is E, it is under IP20/NEMA1/UL TYPE1 protection level.

Frame Size		D0		D		E		F		G		H				
Model VFD-___C__		370	450	550	750	900	1100	1320	1600	1850	2200	2800	3150	3550	4500	
*Output Rating	Normal Duty	Rated Output Capacity [kVA]	58	73	88	120	143	175	207	247	295	367	438	491	544	720
		Rated Output Current [A]	73	91	110	150	180	220	260	310	370	460	550	616	683	866
		Applicable Motor Output [kW]	37	45	55	75	90	110	132	160	185	220	280	315	355	450
		Applicable Motor Output [HP]	50	60	75	100	125	150	175	215	250	300	375	420	475	600
		Overload Capacity	120% of rated output current: 1 minute for every 5 minutes; 160% of rated output current: 3 seconds for every 30 seconds													
		Max. Output Frequency [Hz]	0.00~599.00													
		Carrier Frequency [kHz]	2~10 (Default: 6)				2~9 (Default: 4)									
	Heavy Duty	Rated Output Capacity [kVA]	55	69	84	114	136	167	197	235	280	348	417	466	517	677
		Rated Output Current [A]	69	86	105	143	171	209	247	295	352	437	523	585	649	815
		Applicable Motor Output [kW]	30	37	45	55	75	90	110	132	160	185	220	280	315	355
		Applicable Motor Output [HP]	40	53	60	75	100	125	150	175	215	250	300	375	425	475
		Overload Capacity	150% of rated output current: 1 minute for every 5 minutes; 180% of rated output current: 3 seconds for every 30 seconds													
		Max. Output Frequency [Hz]	0.00~300.00													
		Carrier Frequency [kHz]	2~10 (Default: 2)				2~9 (Default: 2)									
Input Rating	Input Current [A]	Normal Duty	74	101	114	157	167	207	240	300	380	400	494	555	625	866
		Heavy Duty	70	96	108	149	159	197	228	285	361	380	469	527	594	815
	Rated Voltage / Frequency	3-phase AC 380V~480V (-15% +10%), 50 / 60Hz														
	Operating Voltage Range	323~528V <sub>AC</sub>														
Frequency Tolerance	47~63Hz															
Efficiency [%]	97.8					98.2										
Power Factor	>0.98															
Drive Weight [Kg]	27 ± 1.5		38.5 ± 1.5		64.8 ± 1.5		86.5 ± 1.5		134 ± 4		228					
Cooling Method	Fan cooling															
Braking Chopper	Frame D0~H: Optional															
DC choke	Frame D0~H: Built-in															
EMC Filter	Frame D0~H: Optional															
EMC-COP01	VFDXXC43A : Optional; VFDXXC43E: Built-in															

Table 9-3

 **NOTE**

- \* : The factory setting is Normal Duty mode.
- The carrier frequency is default. Increasing the carrier frequency requires a reduction in current. Please refer to Chapter 9-7 Derating Curve of Ambient Temperature.
- The AC motor drive should operate in derating current when its control method is set to FOC Sensorless, TQC+PG, TQC sensorless, PM+PG, PM sensorless Please refer to Pr. 06-55 for more information.
- Select the AC motor drive with capacity one grade larger for the impact load application.
- The rated input current will be affected by not only Power Transformer and the connection of the reactors on input side, but also fluctuates with the impedance of power side.
- For Frame A, B and C, Model VFDXXC43A is under IP20/NEMA1/UL TYPE1 protection level.
- For Frame D and above, if the last character of the model is A then it is under IP20 protection level but the wiring terminal is under IP00 protection level; if the last character of the model is E, it is under IP20/NEMA1/UL TYPE1 protection level.
- Model VFD4500C43x does not have UL certification.

## 9-3 575V Series

Frame Size		A			B				
Model VFD-___C53A-21		015	022	037	055	075	110	150	
*Output Rating	Light Duty	Rated Output Capacity [kVA]	3	4.3	6.7	9.9	12.1	18.6	24.1
		Rated Output Current [A]	3	4.3	6.7	9.9	12.1	18.7	24.2
		Applicable Motor Output [kW]	1.5	2.2	3.7	5.5	7.5	11	15
		Applicable Motor Output [HP]	2	3	5	7.5	10	15	20
	Normal Duty	Rated Output Capacity [kVA]	2.5	3.6	5.5	8.2	10	15.4	19.9
		Rated Output Current [A]	2.5	3.6	5.5	8.2	10	15.5	20
		Applicable Motor Output [kW]	0.75	1.5	2.2	3.7	5.5	7.5	11
		Applicable Motor Output [HP]	1	2	3	5	7.5	10	15
	Heavy Duty	Rated Output Capacity [kVA]	2.1	3	4.6	6.9	8.3	12.9	16.7
		Rated Output Current [A]	2.1	3	4.6	6.9	8.3	13	16.8
		Applicable Motor Output [kW]	0.75	1.5	2.2	3.7	3.7	7.5	7.5
		Applicable Motor Output [HP]	1	2	3	5	5	10	10
	Carrier Frequency [kHz]		2~15 (Default: 6)						
Input Rating	Input Current [A]	Light Duty	3.8	5.4	10.4	14.9	16.9	21.3	26.3
		Normal Duty	3.1	4.5	7.2	12.3	15	18	22.8
		Heavy Duty	2.6	3.8	5.8	10.7	12.5	16.9	19.7
	Rated Voltage / Frequency		3-phase AC 525 ~ 600 V ( -15%~+10%), 50/60 Hz						
	Operating Voltage Range		446~660V <sub>AC</sub>						
Frequency Tolerance		47~63Hz							
Efficiency [%]		97			98				
Power Factor		>0.98							
Drive Weight [Kg]		3 ± 0.3			4.8 ± 1				
Cooling Method		Natural cooling			Fan cooling				
Braking Chopper		Frame A~B: Built-in							
DC choke		Frame A~B: Optional							
EMC Filter		Frame A~B: Optional							

Table 9-4

 **NOTE**

\* Parameter 00-16; available load modes: Light Duty (LD), Normal Duty (ND) and Heavy Duty (HD); default setting is LD mode



### 9-4 690V Series

Frame Size		C				D		E				
Model VFD-___C63B-00 / -21		185	220	300	370	450	550	750	900	1100	1320	
*Output Rating	Light Duty	Rated Output Capacity [kVA]	29	36	43	54	65	80	103	124	149	179
		Applicable Motor Output [690V, kW]	18.5	22	30	37	45	55	75	90	110	132
		Applicable Motor Output [690V, HP]	25	30	40	50	60	75	100	125	150	175
		Applicable Motor Output [575V, HP]	20	25	30	40	50	60	75	100	125	150
		Rated Output Current [A]	24	30	36	45	54	67	86	104	125	150
	Normal Duty	Rated Output Capacity [kVA]	24	29	36	43	54	65	80	103	124	149
		Applicable Motor Output [690V, kW]	15	18.5	22	30	37	45	55	75	90	110
		Applicable Motor Output [690V, HP]	20	25	30	40	50	60	75	100	125	150
		Applicable Motor Output [575V, HP]	15	20	25	30	40	50	60	75	100	125
		Rated Output Current [A]	20	24	30	36	45	54	67	86	104	125
	Heavy Duty	Rated Output Capacity [kVA]	17	24	29	36	43	54	65	80	103	124
		Applicable Motor Output [690V, kW]	11	15	18.5	22	30	37	45	55	75	90
		Applicable Motor Output [690V, HP]	15	20	25	30	40	50	60	75	100	125
		Applicable Motor Output [575V, HP]	10	15	20	25	30	40	50	60	75	100
		Rated Output Current [A]	14	20	24	30	36	45	54	67	86	104
Carrier Frequency [kHz]		2~9 (Default: 4)										
Input Rating	Input Current [A]	Light Duty	29	36	43	54	65	81	84	102	122	147
		Normal Duty	24	29	36	43	54	65	66	84	102	122
		Heavy Duty	20	24	29	36	43	54	53	66	84	102
	Rated Voltage / Frequency		3-phase AC 525 V~ 690 V ( -15%~+10%), 50/60 Hz									
	Operating Voltage Range		446 ~ 759 V <sub>AC</sub>									
Frequency Tolerance		47~63Hz										
Efficiency [%]		97										
Power Factor		>0.98										
Drive Weight [Kg]		10 ± 1.5				39 ± 1.5		61 ± 1.5				
Cooling Method		Fan cooling										
Braking Chopper		Frame C: Built-in				Frame D~E: Optional						
DC choke		Frame C: Optional				Frame D~E: Built-in						
EMC Filter		Frame C~E: Optional										

Table 9-5



\* Parameter 00-16; available load modes: Light Duty (LD), Normal Duty (ND) and Heavy Duty (HD); default setting is LD mode

Frame Size		F		G		H				
Model VFD-___ C63B-00/21		1600	2000	2500	3150	4000	4500	5600	6300	
*Output Rating	Light Duty	Rated Output Capacity [kVA]	215	263	347	418	494.5	534.7	678.5	776
		Applicable Motor Output [690V, kW]	160	200	250	315	400	450	560	630
		Applicable Motor Output [690V, HP]	215	270	335	425	530	600	745	850
		Applicable Motor Output [575V, HP]	175	200	250	350	400	450	500	745
		Rated Output Current [A]	180	220	290	350	430	465	590	675
	Normal Duty	Rated Output Capacity [kVA]	179	215	239	347	402.5	442.7	534.7	776
		Applicable Motor Output [690V, kW]	132	160	200	250	315	355	450	630
		Applicable Motor Output [690V, HP]	175	215	270	335	425	475	600	850
		Applicable Motor Output [575V, HP]	150	175	200	250	350	400	450	745
		Rated Output Current [A]	150	180	220	290	350	385	465	675
	Heavy Duty	Rated Output Capacity [kVA]	149	179	215	263	333.5	356.5	483	776
		Applicable Motor Output [690V, kW]	110	132	160	200	250	280	400	630
		Applicable Motor Output [690V, HP]	150	175	215	270	335	375	530	850
		Applicable Motor Output [575V, HP]	125	150	175	200	250	335	450	745
		Rated Output Current [A]	125	150	180	220	290	310	420	675
Carrier Frequency [kHz]		2~9 (Default: 4)							2~9 (Default: 3)	
Input Rating	Input Current [A]	Light Duty	178	217	292	353	454	469	595	681
		Normal Duty	148	178	222	292	353	388	504	681
		Heavy Duty	123	148	181	222	292	313	423	681
	Rated Voltage / Frequency		3-phase AC 525 V~ 690V ( -15%~+10%), 50/60 Hz							
	Operating Voltage Range		446 ~ 759 V <sub>AC</sub>							
	Frequency Tolerance		47~63 Hz							
Efficiency [%]		97			98					
Power Factor		>0.98								
Drive Weight [Kg]		88 ± 1.5		135 ± 4		243 ± 5				
Cooling Method		Fan cooling								
Braking Chopper		Frame F~H: Optional								
DC choke		Frame F~H: Built-in								
EMC Filter		Frame F~H: Optional								

Table 9-6

 **NOTE**

\* Parameter 00-16; available load modes: Light Duty (LD), Normal Duty (ND) and Heavy Duty (HD); default setting is LD mode

## General Specifications

Control Characteristics	Control Method	230V/ 460V model: 1: V/F, 2: SVC, 3: VF+PG, 4: FOC+PG, 5: TQC+PG, 6: PM+PG, 7: FOC sensorless, 8: TQC sensorless, 9: PM sensorless 575V/ 690V model: 1: V/F, 2: V/F+PG, 3: SVC
	Starting Torque	IM: Reach up to 150% of 1/50 rated speed PM: Reach up to 150% of 1/100 rated speed
	V/F Curve	4 point adjustable V/F curve and square curve
	Speed Circuit Response Bandwidth	Open-circuit: 5Hz Close-circuit: Max. 40Hz for IM, and Max. 100Hz for PM
	Torque Limit	230V/ 460V model: Normal duty: a max. of 160% torque current; Heavy duty: a max. of 180% torque current 575V/ 690V model: Max. 200% torque current
	Torque Accuracy	TQC + PG: $\pm 5\%$ TQC Sensorless: $\pm 15\%$
	Max. Output Frequency (Hz)	Normal duty: 0.01~599.00Hz; Heavy duty: 0.00~300.00 Hz
	Frequency Output Accuracy	Digital command: $\pm 0.01\%$ , $-10^{\circ}\text{C} \sim +40^{\circ}\text{C}$ ; Analog command: $\pm 0.1\%$ , $25 \pm 10^{\circ}\text{C}$
	Output Frequency Resolution	Digital command: 0.1Hz, Analog command: 0.05% X max. output frequency (Pr.01-00) / 11 bit
	Overload Tolerance	230V/ 460V model: Normal duty: 120% of rated current can endure for 1 minute during every 5 minutes 160% of rated current can endure for 3 seconds during every 30 seconds. Heavy duty: 150% of rated current can endure for 1 minute during every 5 minutes 180% of rated current can endure for 3 seconds during every 30 seconds.
		575V/ 690V model: Light duty: 120% of rated current can endure for 1 minute. Normal duty: 120% of rated current can endure for 1 minute, 150% can endure for 3 seconds. Heavy duty: 150% of rated current can endure for 1 minute, 180% can endure for 3 seconds.
	Frequency Setting Signal	-10~ +10V, 0~ +10V, 4~20mA, 0~20mA, Pulse input
	Accel. / decel. Time	0.00~600.00 / 0.0~6000.0 seconds
	Main Control Function	Torque control, Speed/torque control switching, Feed forward control, Zero-servo control, Momentary power loss ride thru, Speed search, Over-torque detection, Torque limit, 16-step speed (max), Accel. / decel. time switch, S-curve accel. / decel., 3-wire sequence, Auto-Tuning (rotational, stationary), Dwell, Slip compensation, Torque compensation, JOG frequency, Frequency upper / lower limit settings, DC injection braking at start / stop, High slip braking, PID control (with sleep function), Energy saving control, MODBUS communication (RS-485 RJ45, max. 115.2 Kbps), Fault restart, Parameter copy
Fan Control	230V model: Models above VFD150C23A (including VFD150C23A) are PWM control Models below VFD110C23A (including VFD110C23A) are ON / OFF switch control 460V model: Models above VFD185C43A (including VFD185C43A) are PWM control Models below VFD150C43A (including VFD150C43A) are ON / OFF switch control 575V/ 690V model: PWM control	
Protection Characteristics	Motor Protection	Electronic thermal relay protection
	Over-current Protection	For drive model 230V and 460V Over-current protection: 240% rated current for normal duty; 250% rated current for heavy duty Current clamp 『Normal duty: 170~175%』; 『Heavy duty: 175~180%』
		For drive model 575V and 690V (except 630kW) Over-current protection: 240% rated current for normal duty Current clamp 『Light duty: 125~145%』; 『Normal duty: 170~175%』; 『Heavy duty: 200~250%』 For 630kW Over-current protection: 240% rated current for normal duty Current clamp 『Light duty, normal duty, and heavy duty: 170~175%』
		230V model: drive will stop when DC-BUS voltage exceeds 410V 460V model: drive will stop when DC-BUS voltage exceeds 820V 690V model: drive will stop when DC-BUS voltage exceeds 1189V
	Over-temperature Protection	Built-in temperature sensor



	Stall Prevention	Stall prevention during acceleration, deceleration and running independently
	Restart after Instantaneous Power Failure	Parameter setting up to 20 seconds
	Grounding Leakage Current Protection	Leakage current is higher than 50% of rated current of the AC motor drive
	Short-circuit Current Rating (SCCR)	Per UL 508C, the drive is suitable for use on a circuit capable of delivering not more than 100kA symmetrical amperes (rms) when protected by fuses given in the fuse table.
	Certifications	   GB/T12668-2

Table 9-7

 **NOTE**

The setting range of max. output frequency changes as carrier wave and control modes changes. Refer to Pr. 01-00 and Pr. 06-55 for more information.

Model VFD4500C43x does not have UL certification.

### 9-5 Environment for Operation, Storage and Transportation

DO NOT expose the AC motor drive in the bad environment, such as dust, direct sunlight, corrosive / inflammable gasses, humidity, liquid and vibration environment. The salt in the air must be less than 0.01mg / cm <sup>2</sup> every year.				
Environment	Installation location	IEC60364-1 / IEC60664-1 Pollution degree 2, Indoor use only		
	Surrounding Temperature (°C)	Storage / Transportation	-25 ~ +70	
		Non-condensation, non-frozen		
	Rated Humidity	Operation	Max. 95%	
		Storage / Transportation	Max. 95%	
		No condense water		
	Air Pressure (kPa)	Operation / Storage	86~106	
		Transportation	70~106	
	Pollution Level	IEC 60721-3-3		
		Operation	Class 3C3; Class 3S2	
Storage		Class 1C2; Class 1S2		
Transportation		Class 2C2; Class 2S2		
If the AC motor drive is to be used under harsh environment with high level of contamination (e.g. dew, water, dust), make sure it is installed in an environment qualified for IP54 such as in a cabinet.				
Altitude	Operation	If AC motor drive is installed at altitude 0~1000m, follow normal operation restriction. If it is installed at altitude 1000~2000m, decrease 1% of rated current or lower 0.5°C of temperature for every 100m increase in altitude. Maximum altitude for Corner Grounded is 2000m.		
Package Drop	Storage	ISTA procedure 1A (according to weight) IEC60068-2-31		
	Transportation			
Vibration	1.0mm, peak to peak value range from 2Hz to 13.2 Hz; 0.7G~1.0G range from 13.2Hz to 55Hz; 1.0G range from 55Hz to 512Hz. Comply with IEC 60068-2-6			
Impact	IEC / EN 60068-2-27			
Operation Position	Max. allowed offset angle ±10° (under normal installation position)			

Table 9-8

## 9-6 Specification for Operation Temperature and Protection Level

Model	Frame	Top cover	Conduit Box	Protection Level	Operation Temperature
VFDxxxCxxA VFDxxxCxxS	Frame A~C 230V: 0.75~22kW 460V: 0.75~30kW	Top cover removed	Standard conduit plate	IP20 / UL Open Type	-10~50°C
		Standard with top cover		IP20 / UL Type1 / NEMA1	-10~40°C
	Frame D~H 230V: ≥ 22kW 460V: ≥ 30kW	N / A	No conduit box	IP00 IP20 / UL Open Type  Figure 9-1	-10~50°C
VFDxxxCxxE VFDxxxCxxU	Frame A~C 460V: 0.75~30kW	Top cover removed	Standard conduit plate	IP20 / UL Open Type	-10~50°C
		Standard with top cover		IP20 / UL Type1 / NEMA1	-10~40°C
	Frame D~H 230V: ≥ 22kW 460V: ≥ 30kW	N / A	Standard conduit box	IP20 / UL Type1 / NEMA1	-10~40°C

Table 9-9

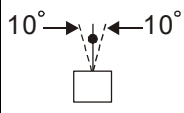
### 9-7 Derating Curve of Ambient Temperature

Protection Level	Operating Environment
UL Type I / IP20	230V / 460V: When the AC motor drive operates at the rated current, and the ambient temperature has to be between -10 ~ +40°C. When the temperature is over 40°C, the rated current decreases 2% for every increase by 1°C. The maximum allowable temperature is 60°C. 575V / 690V: When the AC motor drive operates at the rated current, and the ambient temperature has to be between -10 ~ +40°C. When the temperature is over 40°C, the rated current decreases 2.5% for every increase by 1°C. The maximum allowable temperature is 60°C.
UL Open Type / IP20	230V / 460V: When the AC motor drive operates at the rated current, and the ambient temperature has to be between -10 ~ +50°C. When the temperature is over 50°C, the rated current decreases 2% for every increase by 1°C. The maximum allowable temperature is 60°C. 575V / 690V: When the AC motor drive operates at the rated current, and the ambient temperature has to be between -10 ~ +50°C. When the temperature is over 50°C, the rated current decreases 2.5% for every increase by 1°C. The maximum allowable temperature is 60°C.
High Altitude	If AC motor drive is installed at altitude 0~1000m, follow normal operation restriction. If it is install at altitude 1000~2000m, decrease 1% of rated current or lower 0.5°C of temperature for every 100m increase in altitude. Maximum altitude for Corner Grounded is 2000m. Contact Delta for more information, if you need to use this motor drive at an altitude of 2000m or higher.

Table 9-10

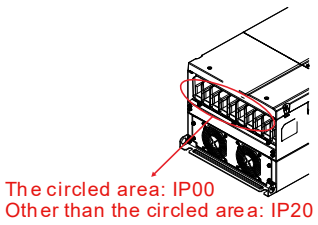
#### Ambient temperature derating curve

230V / 460V Normal control ambient temperature derating curve

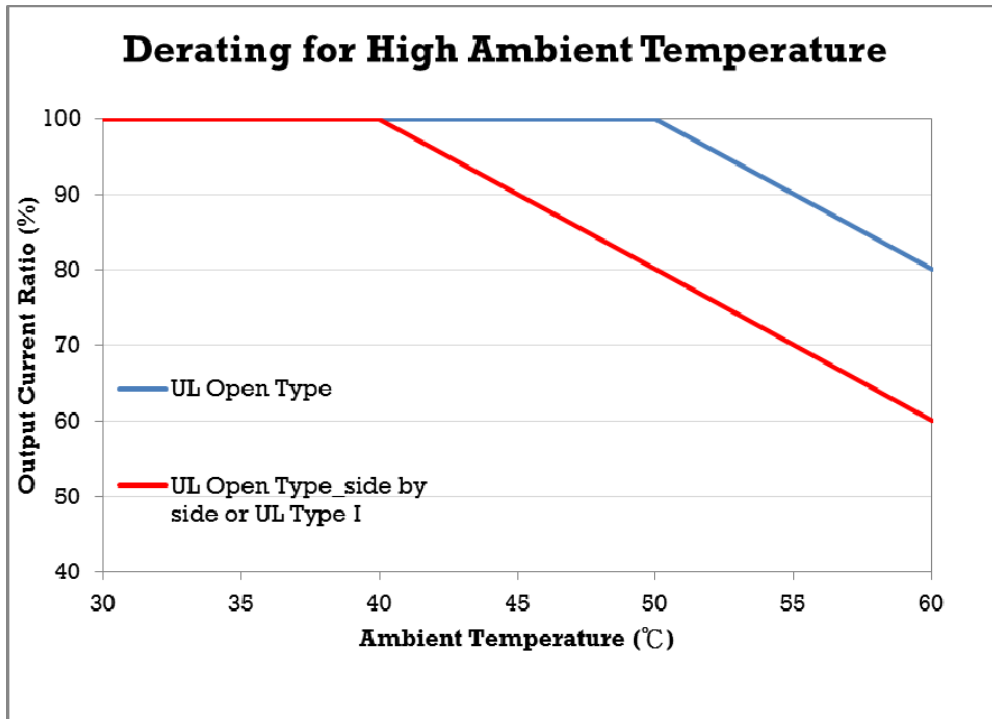

Figure 9-2

230V / 460V Advanced control ambient temperature derating curve

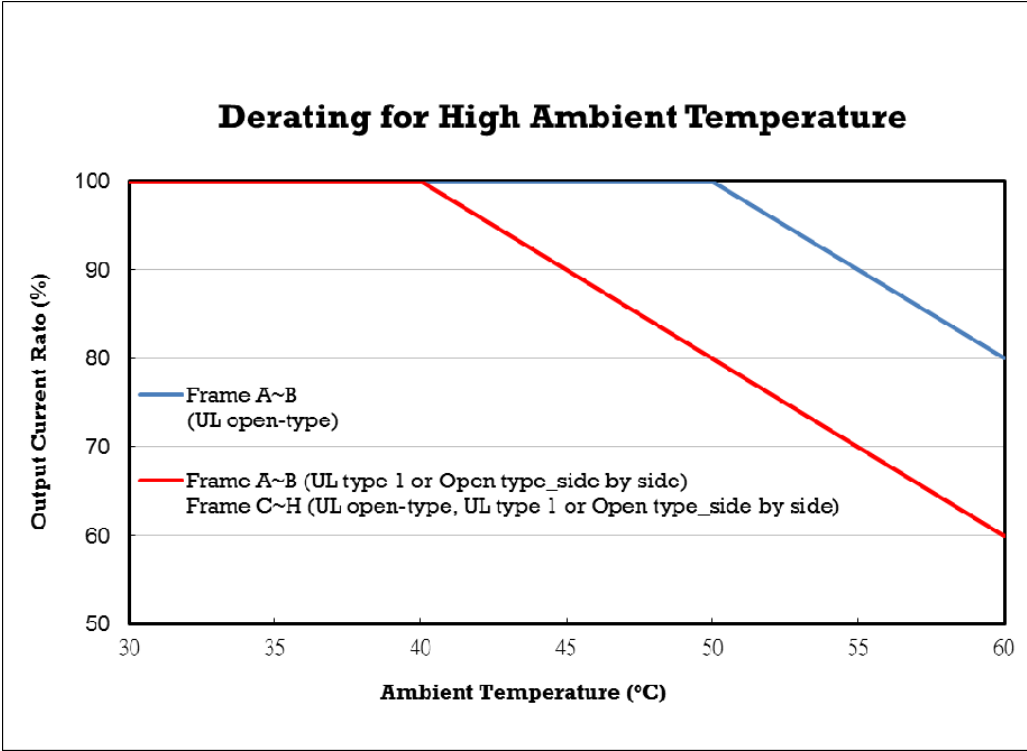

Figure 9-3

575V / 690V Ambient temperature derating curve

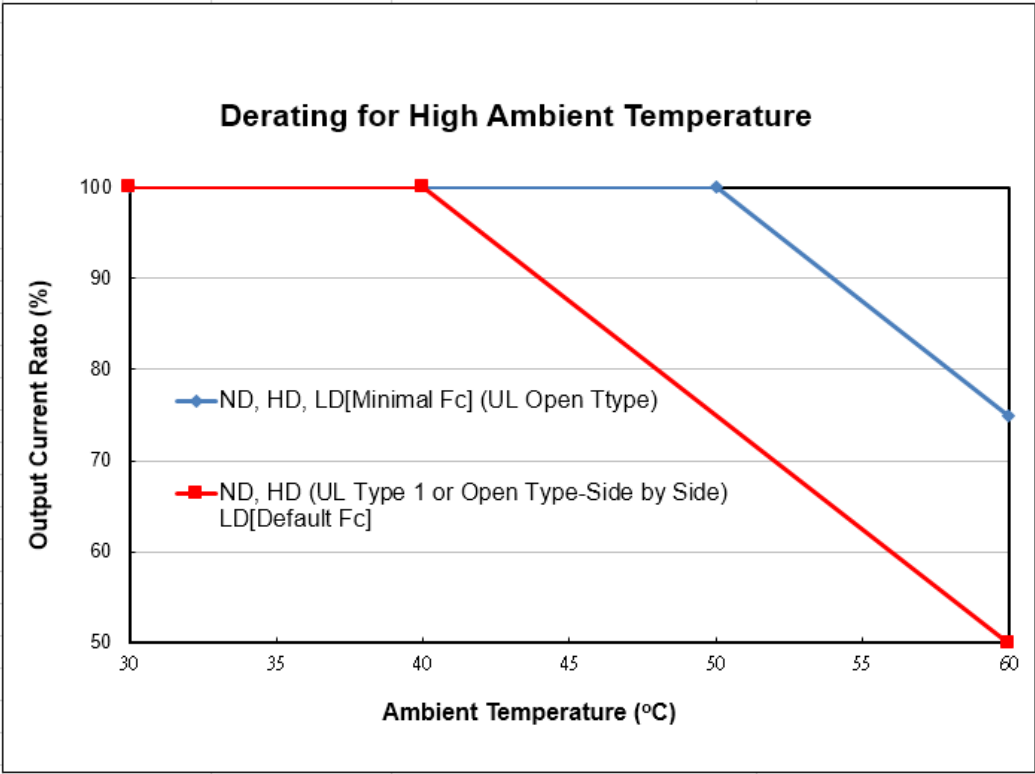

Figure 9-4



**Current derating at high altitude**

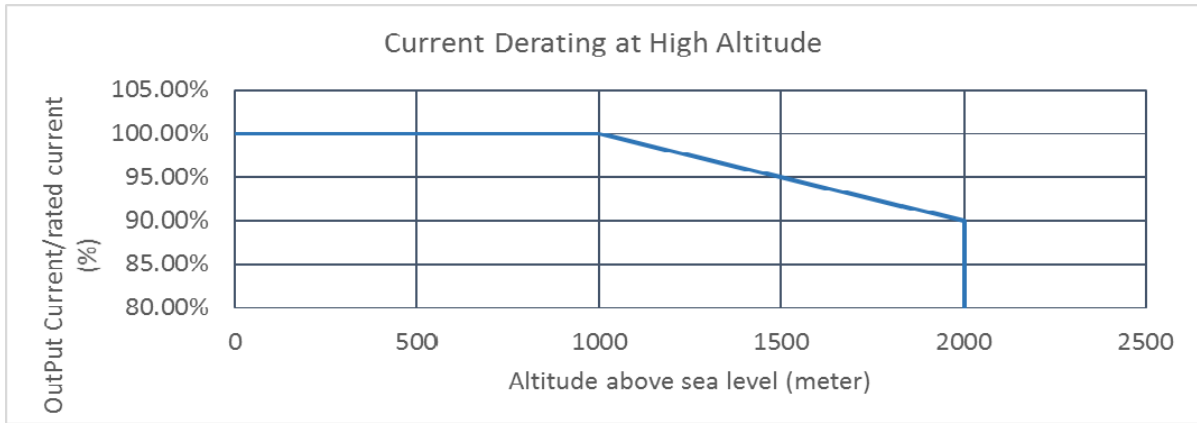

Figure 9-5

Table 9-10

**Carrier wave derating curve**

230V / 460V

General Control Derating Curve (Pr.00-10=1 and Pr.00-11=0~3)

In Normal Duty mode (Pr.00-16=0)

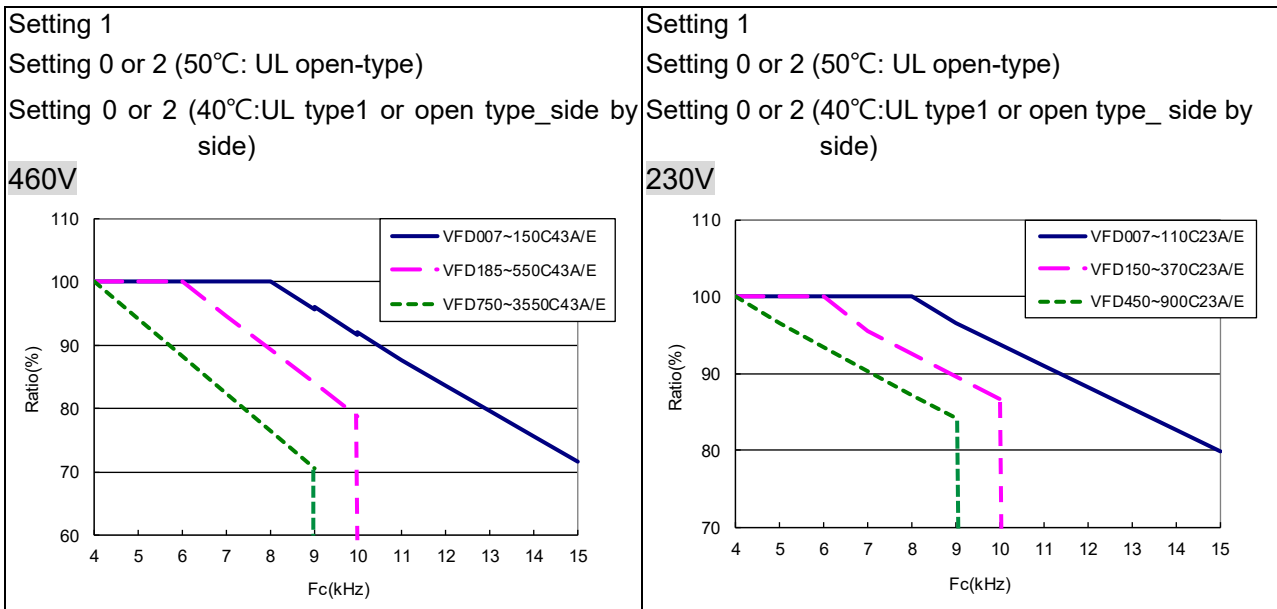

In Heavy Duty mode (Pr.00-16=1)

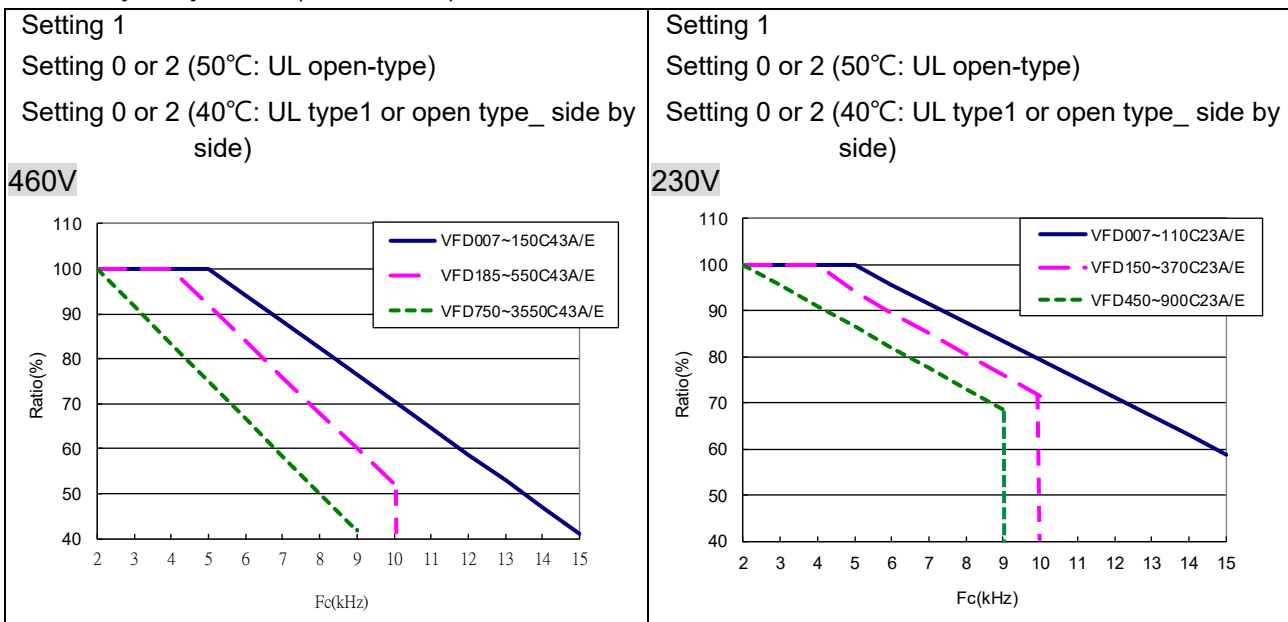

Advanced Control Derating Curve (Pr.00-10=1, and Pr.00-11=4~7; or Pr.00-10=3, and Pr.00-13=1~3)  
 In Normal Duty mode (Pr.00-16=0)

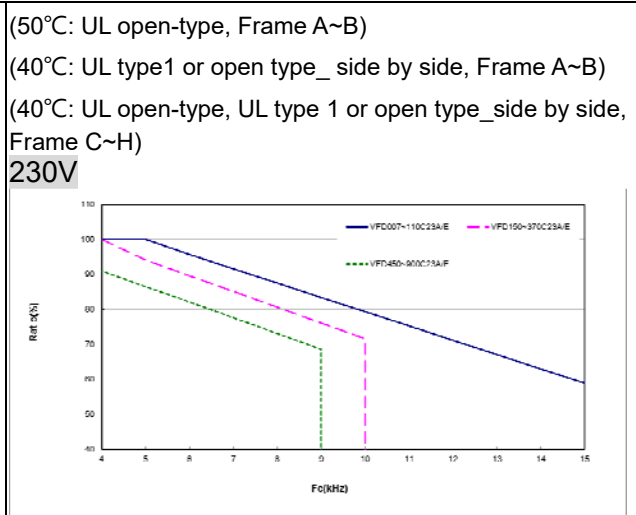
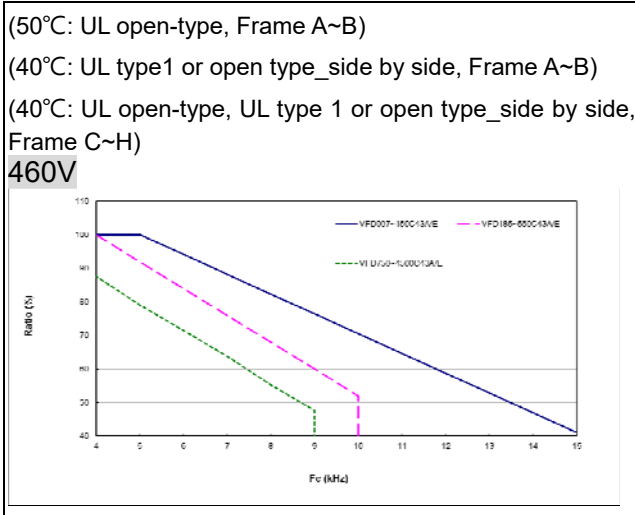

In Heavy Duty mode (Pr.00-16=1)

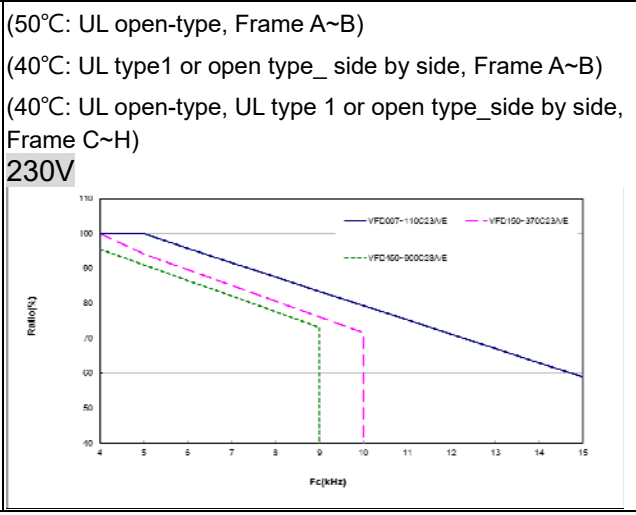
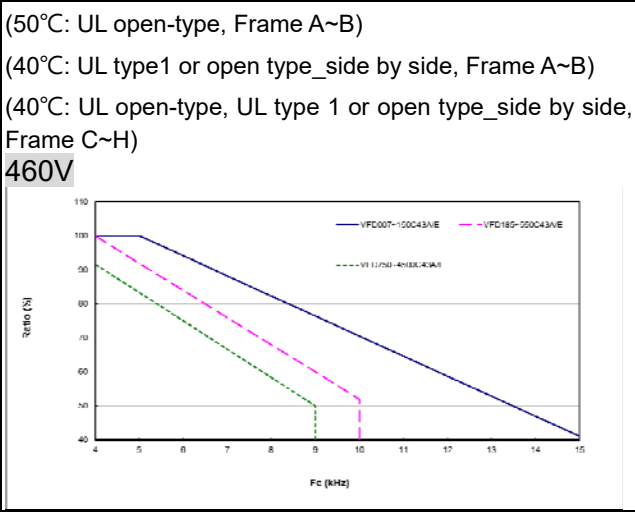

575V Derating Curve (Pr.00-16=0 or 1 or 2)

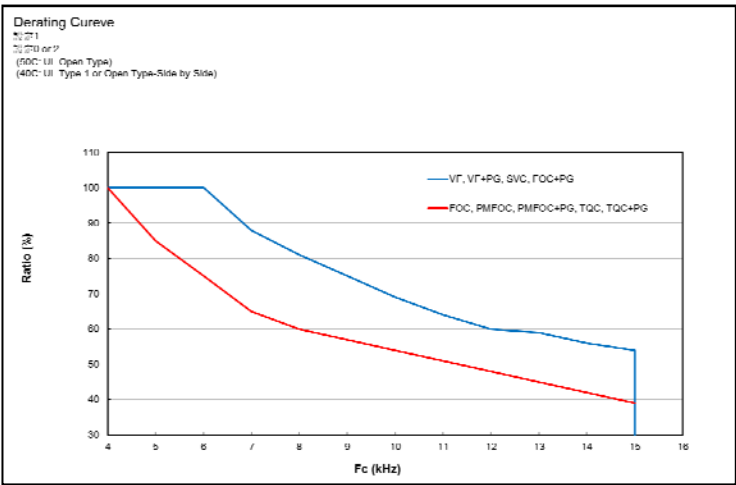

Figure 9-6

### 690V Derating Curve

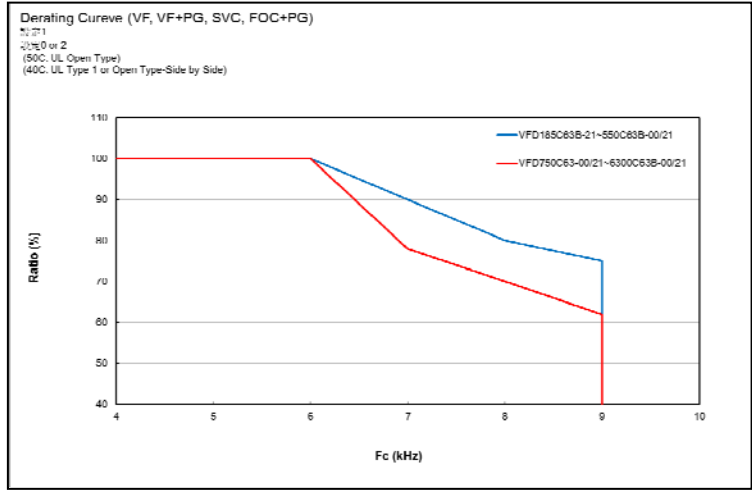

Figure 9-7

### 9-8 Efficiency Curve

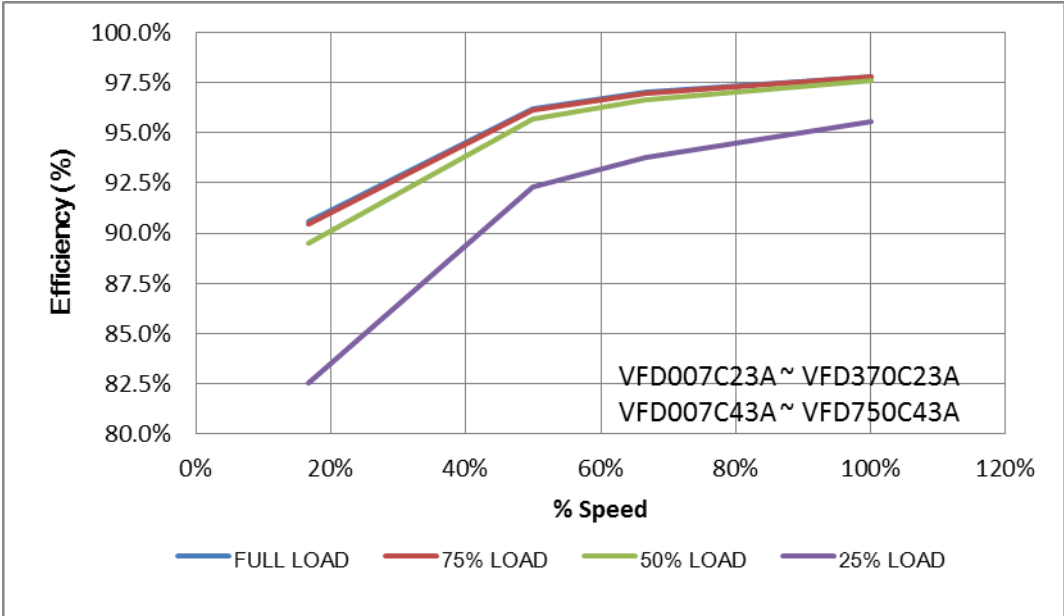

Figure 9-8

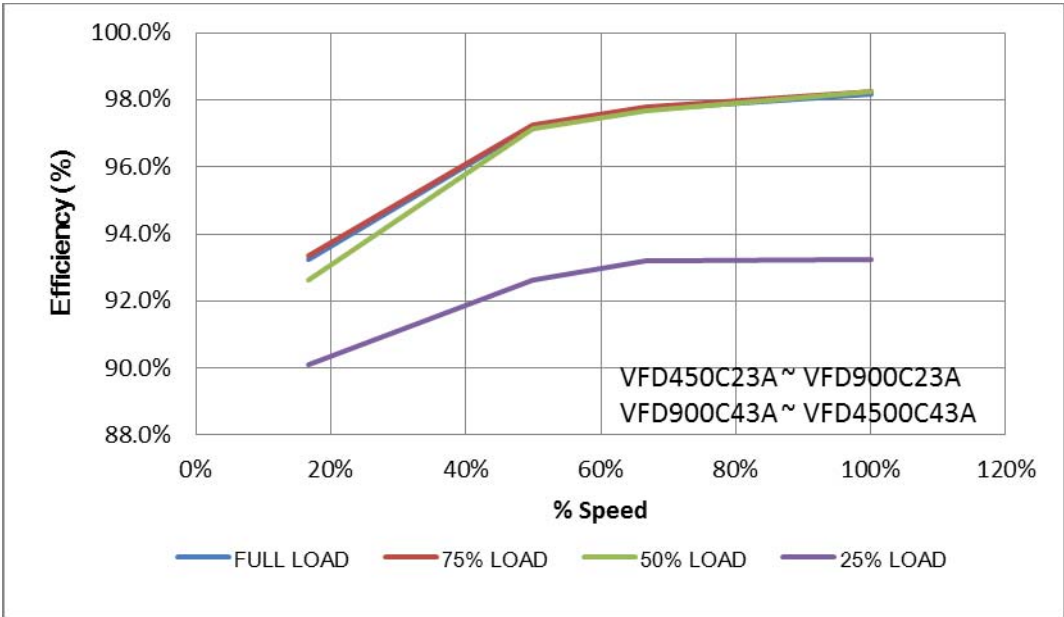

Figure 9-9

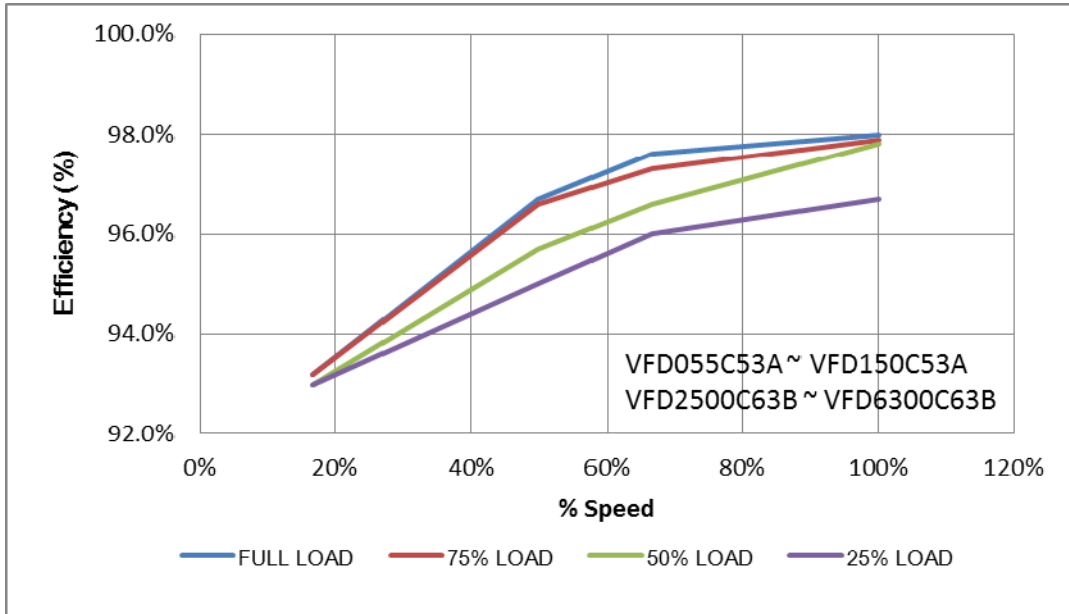

Figure 9-10

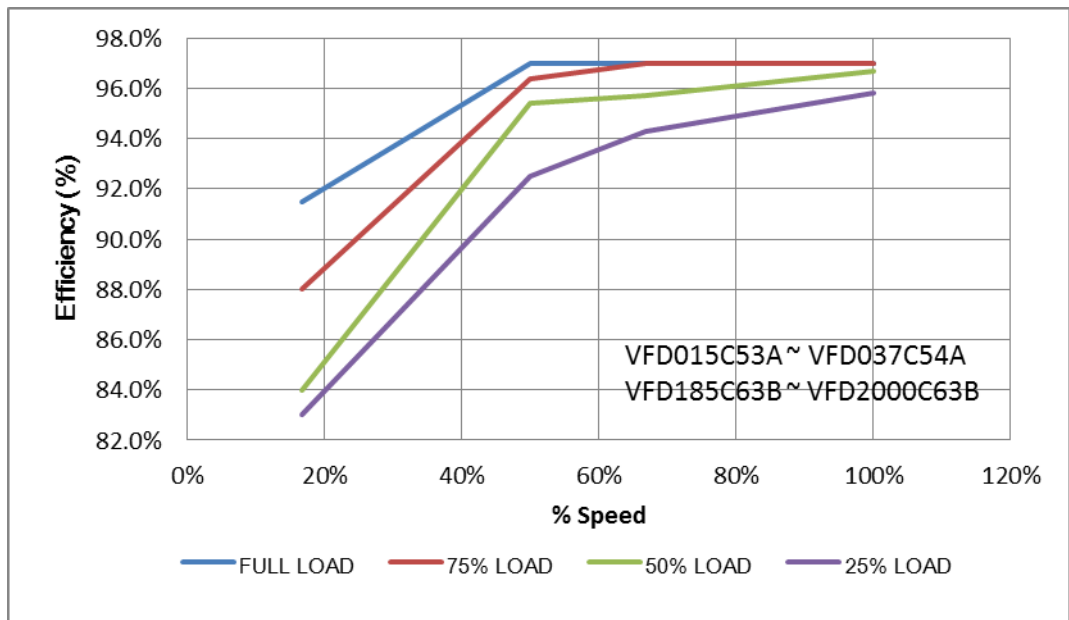

Figure 9-11

# ***Chapter 10 Digital Keypad***

---

10-1 Descriptions of Digital Keypad

10-2 Function of Digital Keypad KPC-CC01

10-3 TPEditor Installation Instruction

10-4 Fault Code Description of Digital Keypad KPC-CC01

10-5 Unsupported Functions when using TPEditor on  
KPC-CC01 Keypad

### 10-1 Descriptions of Digital Keypad

The default communication format is ASCII 9600, 7, N, 2 in C2000. But the communication format is RTU 19200, 8, N, 2. To enable the communication between C2000 and KPC-CC01, you need to set up the communication parameters of C2000 before linking the drive and the keypad (KPC-CC01).

Follow the set-up steps below:

- Set Pr.09-00 = 1 (the communication address)
- Set Pr.09-01 = 19.2 kbps (the COM1 transmission speed)
- Set Pr.09-04 = 13 (8, N, 2; RTU) (the COM1 communicatino protocol)







**KPC-CC01**  
Communication Interface  
RJ45 (socket), RS-485 interface

**Installation Method**

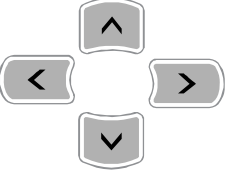

1. Embedded type and can be put flat on the surface of the control box. The front cover is water proof.
2. Buy a MKC-KPPK model to do wall mounting or embedded mounting. Its protection level is IP66.
3. The maximum RJ45 extension lead is 5 m (16ft)
4. This keypad can only be used on Delta’s motor drive C2000, CH2000 and CP2000.

### Descriptions of Keypad Functions











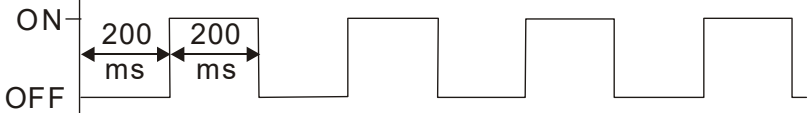
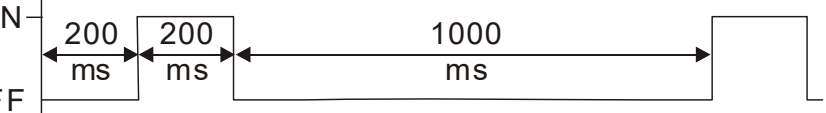

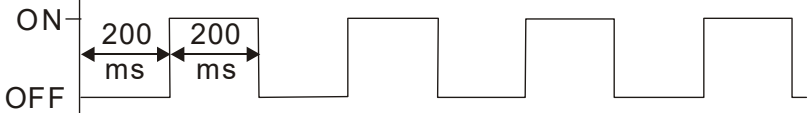
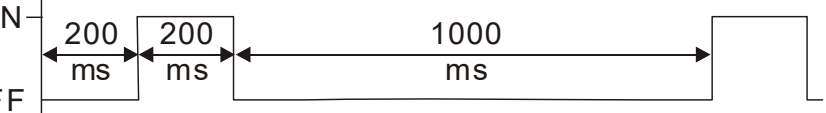
Key	Descriptions																		
	<p>Start Operation Key</p> <ol style="list-style-type: none"> <li>1. It is only valid when the source of operation command is from the keypad.</li> <li>2. It can operate the AC motor drive by the function setting and the RUN LED will be ON.</li> <li>3. It can be pressed again and again at stop process.</li> </ol>																		
	<p>Stop Command Key. This key has the highest priority in any situation.</p> <ol style="list-style-type: none"> <li>1. When it receives STOP command, no matter if the AC motor drive is in operation or stop status, the AC motor drive needs to execute “STOP” command.</li> <li>2. The RESET key can be used to reset the drive after the fault occurs.</li> <li>3. The reasons why the error cannot be reset:                             <ol style="list-style-type: none"> <li>a. Because the condition which triggers the fault is not cleared. When the condition is cleared, the fault can be reset.</li> <li>b. Because it’s the fault status checking when power-on. When the condition is cleared, re-power again, and the fault can be reset.</li> </ol> </li> </ol>																		
	<p>Operation Direction Key</p> <ol style="list-style-type: none"> <li>1. This key only controls the operation direction, and will NOT activate the drive. FWD: forward, REV: reverse.</li> <li>2. Refer to the LED descriptions for more details.</li> </ol>																		
	<p>ENTER Key</p> <p>Press ENTER and go to the next level. If it is the last level then press ENTER to execute the command.</p>																		
	<p>ESC Key</p> <p>ESC key function is to leave current menu and return to the last menu. It also functions as a return key or cancel key in the sub-menu.</p>																		
	<p>Press menu to return to main menu.</p> <p>Menu content:</p> <table style="width: 100%; border: none;"> <tr> <td style="width: 33%;">1. Parameter Setup</td> <td style="width: 33%;">7. Language Setup</td> <td style="width: 33%;">13. Startup Menu</td> </tr> <tr> <td>2. Quick Start</td> <td>8. Time Setup</td> <td>14. Main Page</td> </tr> <tr> <td>3. Application Selection List</td> <td>9. Keypad Locked</td> <td>15. PC Link</td> </tr> <tr> <td>4. Changed List</td> <td>10. PLC Function</td> <td>16. Start Wizard</td> </tr> <tr> <td>5. Copy Parameter</td> <td>11. Copy PLC</td> <td></td> </tr> <tr> <td>6. Fault Record</td> <td>12. Display Setup</td> <td></td> </tr> </table>	1. Parameter Setup	7. Language Setup	13. Startup Menu	2. Quick Start	8. Time Setup	14. Main Page	3. Application Selection List	9. Keypad Locked	15. PC Link	4. Changed List	10. PLC Function	16. Start Wizard	5. Copy Parameter	11. Copy PLC		6. Fault Record	12. Display Setup	
1. Parameter Setup	7. Language Setup	13. Startup Menu																	
2. Quick Start	8. Time Setup	14. Main Page																	
3. Application Selection List	9. Keypad Locked	15. PC Link																	
4. Changed List	10. PLC Function	16. Start Wizard																	
5. Copy Parameter	11. Copy PLC																		
6. Fault Record	12. Display Setup																		

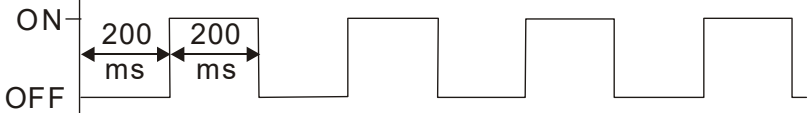
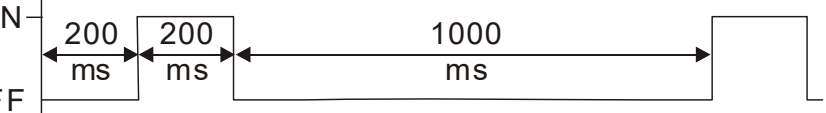
Key	Descriptions
	<p>Direction: Left / Right / Up / Down</p> <ol style="list-style-type: none"> <li>In the numeric value setting mode, it is used to move the cursor and change the numeric value.</li> <li>In the menu/text selection mode, it is used for item selection.</li> </ol>
	<p>Function Key</p> <ol style="list-style-type: none"> <li>The functions keys have factory settings and can be defined by users. The factory settings of F1 and F4 work with the function list below. For example, F1 is JOG function, F4 is a speed setting key for adding/deleting user defined parameters.</li> <li>Other functions must be defined by TPEditor first (please use version 1.60 or above). TPEditor software can be downloaded at:  <a href="http://www.deltaww.com/services/DownloadCenter2.aspx?seclD=8&amp;pid=2&amp;tid=0&amp;CID=06&amp;itemID=060302&amp;typeID=1&amp;downloadID=&amp;title=- Select Product Series --&amp;dataType=8;&amp;check=1&amp;hl=en-US">http://www.deltaww.com/services/DownloadCenter2.aspx?seclD=8&amp;pid=2&amp;tid=0&amp;CID=06&amp;itemID=060302&amp;typeID=1&amp;downloadID=&amp;title=- Select Product Series --&amp;dataType=8;&amp;check=1&amp;hl=en-US</a>  Please refer to instruction for TPEditor in Chapter 10-3.</li> </ol>
	<p>HAND Key</p> <ol style="list-style-type: none"> <li>This key is executed by the parameter settings of the source of Hand frequency and hand operation. The factory settings of both source of Hand frequency and hand operation are the digital keypad.</li> <li>Press HAND key at stop status, the setting will switch to hand frequency source and hand operation source. Press HAND key at operation status, it stops the AC motor drive first (display AHSP warning), and switch to hand frequency source and hand operation source. KPC-CC01 displays HAND mode on the screen.</li> <li>KPC-CC01 displays HAND mode on the screen.</li> </ol>
	<p>AUTO Key</p> <ol style="list-style-type: none"> <li>This key is executed by the parameter settings of the source of AUTO frequency and AUTO operation. The factory setting is the external terminal (source of operation is 4~20mA).</li> <li>Press Auto key at stop status, the setting will switch to hand frequency source and hand operation source. Press Auto key at operation status, it stops the AC motor drive first (display AHSP warning), and switch to auto frequency source and auto operation source.</li> <li>KPC-CC01 displays AUTO mode on the screen</li> </ol>

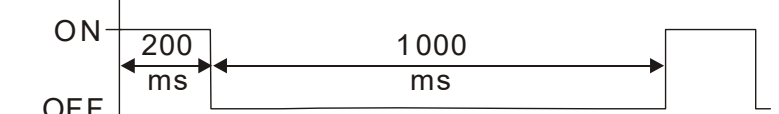
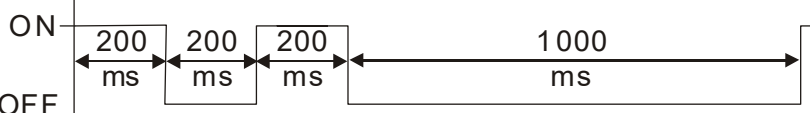
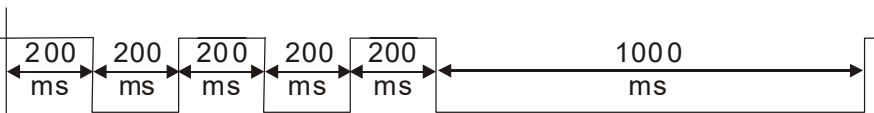
## Descriptions of LED Functions

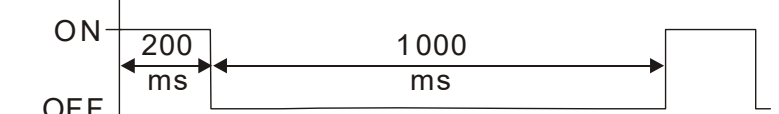
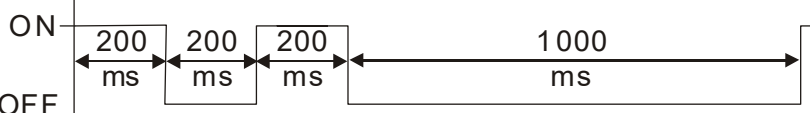
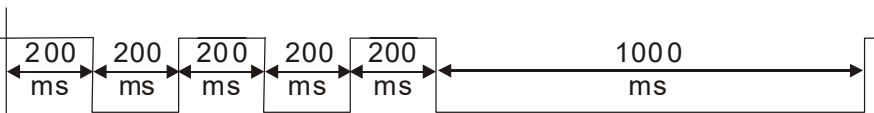
LED	Descriptions
	<p>Steady ON: operation indicator of the AC motor drive, including DC brake, zero speed, standby, restart after fault and speed search.</p> <p>Blinking: drive is decelerating to stop or in the status of base block.</p> <p>Steady OFF: drive doesn't execute the operation command</p>
	<p>Steady ON: stop indicator of the AC motor drive.</p> <p>Blinking: drive is in the standby status.</p> <p>Steady OFF: drive doesn't execute "STOP" command.</p>
	<p>Operation Direction LED</p> <ol style="list-style-type: none"> <li>Green light is on, the drive is running forward.</li> <li>Red light is on, the drive is running backward.</li> <li>Twinkling light: the drive is changing direction.</li> </ol> <p>Operation Direction LED under Torque Mode</p> <ol style="list-style-type: none"> <li>Green light is ON: when the torque command <math>\geq 0</math>, and the motor is running forward.</li> <li>Red light is ON: when the torque command <math>&lt; 0</math>, and the motor is running backward.</li> <li>Twinkling light: when the torque command <math>&lt; 0</math>, and the motor is running forward.</li> </ol>

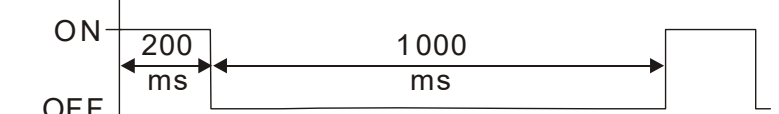
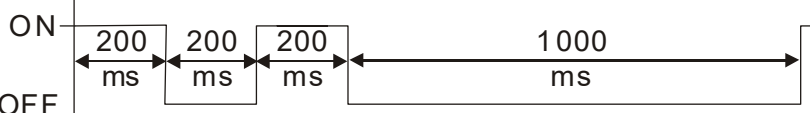
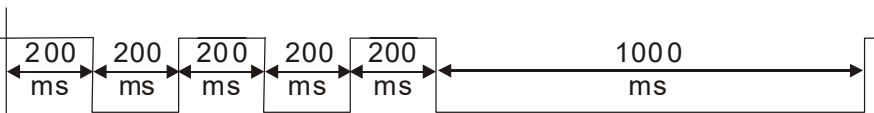

LED	Descriptions												
CANopen~ "RUN"	<p><b>RUN LED:</b></p> <table border="1"> <thead> <tr> <th data-bbox="347 219 475 280">LED status</th> <th data-bbox="475 219 1452 280">Condition/ State</th> </tr> </thead> <tbody> <tr> <td data-bbox="347 280 475 342">OFF</td> <td data-bbox="475 280 1452 342">CANopen at initial No LED</td> </tr> <tr> <td data-bbox="347 342 475 517">Blinking</td> <td data-bbox="475 342 1452 517">                     CANopen at pre-operation   </td> </tr> <tr> <td data-bbox="347 517 475 701">Single flash</td> <td data-bbox="475 517 1452 701">                     CANopen at stopped   </td> </tr> <tr> <td data-bbox="347 701 475 790">ON</td> <td data-bbox="475 701 1452 790">                     CANopen at operation status   </td> </tr> </tbody> </table>	LED status	Condition/ State	OFF	CANopen at initial No LED	Blinking	CANopen at pre-operation 	Single flash	CANopen at stopped 	ON	CANopen at operation status 		
	LED status	Condition/ State											
	OFF	CANopen at initial No LED											
	Blinking	CANopen at pre-operation 											
	Single flash	CANopen at stopped 											
	ON	CANopen at operation status 											
CANopen~ "ERR"	<p><b>ERR LED:</b></p> <table border="1"> <thead> <tr> <th data-bbox="347 869 475 929">LED status</th> <th data-bbox="475 869 1452 929">Condition/ State</th> </tr> </thead> <tbody> <tr> <td data-bbox="347 929 475 969">OFF</td> <td data-bbox="475 929 1452 969">No Error</td> </tr> <tr> <td data-bbox="347 969 475 1153">Single flash</td> <td data-bbox="475 969 1452 1153">                     One message fail   </td> </tr> <tr> <td data-bbox="347 1153 475 1328">Double flash</td> <td data-bbox="475 1153 1452 1328">                     Guarding fail or heartbeat fail   </td> </tr> <tr> <td data-bbox="347 1328 475 1512">Triple flash</td> <td data-bbox="475 1328 1452 1512">                     SYNC fail   </td> </tr> <tr> <td data-bbox="347 1512 475 1601">ON</td> <td data-bbox="475 1512 1452 1601">                     Bus off   </td> </tr> </tbody> </table>	LED status	Condition/ State	OFF	No Error	Single flash	One message fail 	Double flash	Guarding fail or heartbeat fail 	Triple flash	SYNC fail 	ON	Bus off 
	LED status	Condition/ State											
	OFF	No Error											
	Single flash	One message fail 											
	Double flash	Guarding fail or heartbeat fail 											
	Triple flash	SYNC fail 											
ON	Bus off 												

## 10-2 Function of Digital Keypad KPC-CC01

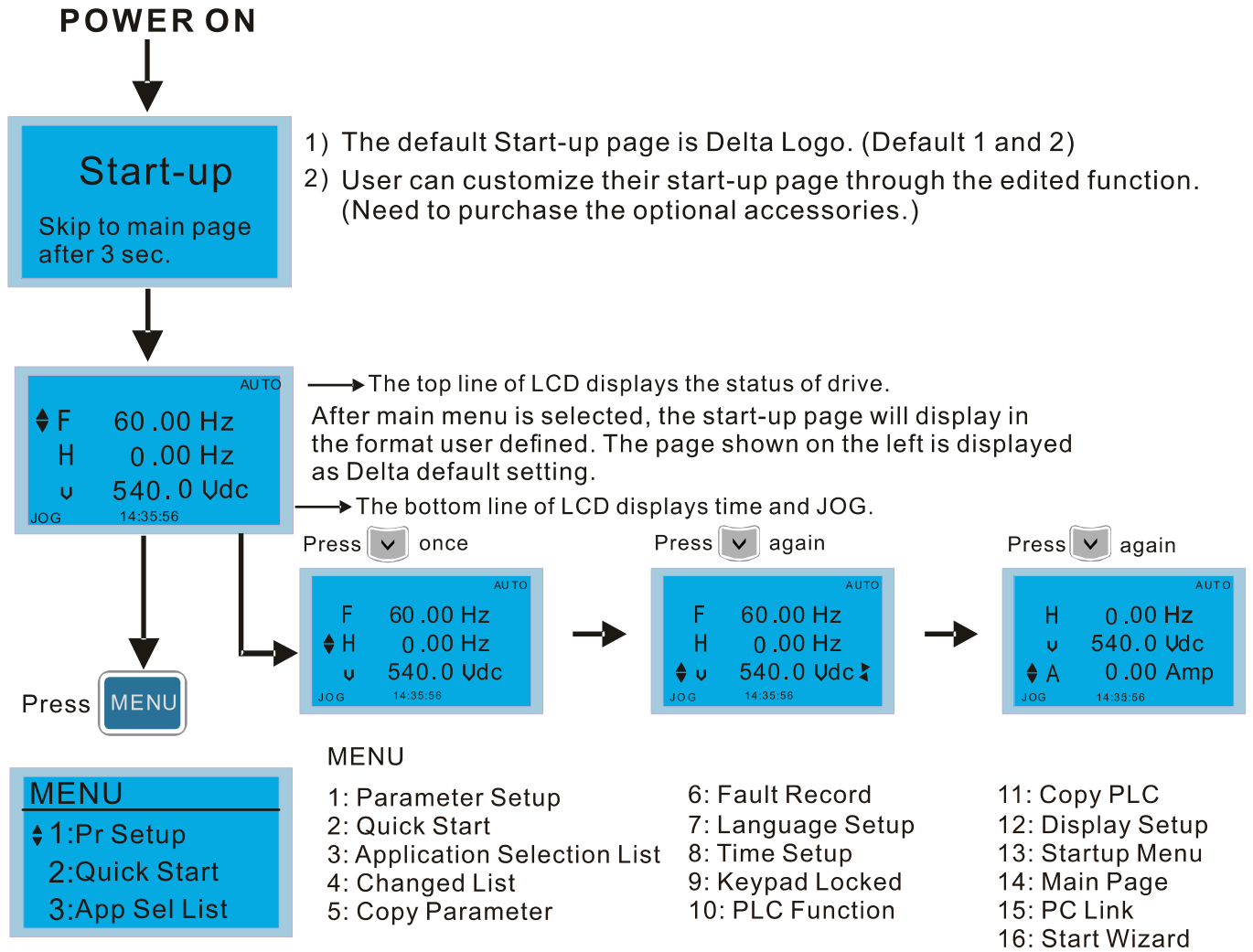

**NOTE**

1. Startup page can only display pictures, no flash.
2. When Power ON, it will display startup page then the main page. The main page displays Delta's default setting F/H/A/U, the display order can be set by Pr.00.03 (Startup display). When the selected item is U page, use left key and right key to switch between the items, the display order of U page is set by Pr.00.04 (User display).

### Display Icon

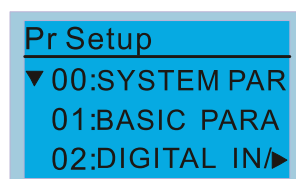
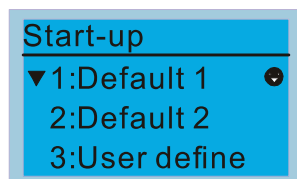

- : present setting
- ▼ : roll down the page for more options

Press for more options



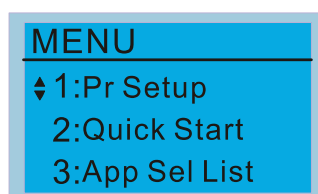

- ▶ : show complete sentence
- Press for complete information

### Display item



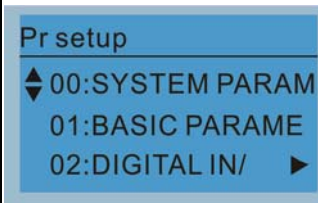

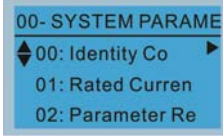
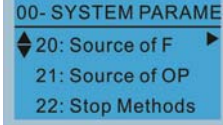
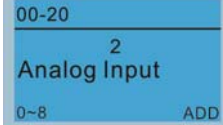
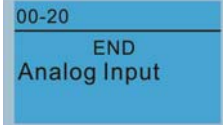
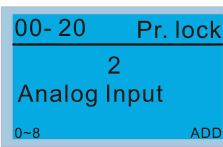

- MENU**
- |                               |                   |                   |
|-------------------------------|-------------------|-------------------|
| 1: Parameter Setup            | 6: Fault Record   | 11: Copy PLC      |
| 2: Quick Start                | 7: Language Setup | 12: Display Setup |
| 3: Application Selection List | 8: Time Setup     | 13: Startup Menu  |
| 4: Changed List               | 9: Keypad Locked  | 14: Main Page     |
| 5: Copy Parameter             | 10: PLC Function  | 15: PC Link       |
|                               |                   | 16: Start Wizard  |

1. Parameter Setup

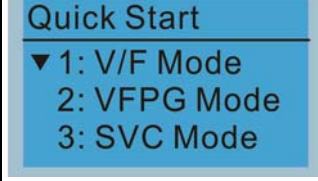
 <p>Press  to select.</p> <p>Press  to select a parameter group.</p> <p>Once a parameter group is selected, press  to go into that group.</p>	<p>For example: Setup source of master frequency command.</p>  <p>Once in the Group 00 Motor Drive Parameter, Use Up/Down key to select parameter 20: Auto Frequency Command.</p>  <p>When this parameter is selected, press ENTER key to go to this parameter's setting menu.</p>  <p>Use Up/Down key to choose a setting. For example: Choose "2 Analogue Input", then press the ENTER key.</p>  <p>After pressing the ENTER key, an END will be displayed which means that the parameter setting is done.</p>  <p>NOTE: When parameter lock/ password protection function is enabled, it will display "Pr. lock" on the right-up corner of the keypad. The parameter cannot be written or is protected by the password under this circumstances.</p>
---	--

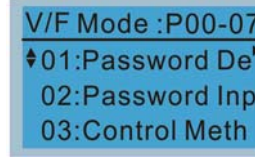
2. Quick Start

 <p>Press  to select.</p> <p>Quick Start:</p> <ol style="list-style-type: none"> <li>1. V/F Mode</li> <li>2. VFPG Mode</li> <li>3. SVC Mode</li> <li>4. FOCPG Mode</li> <li>5. TQCPG Mode</li> <li>6. My Mode</li> </ol>	<p>Description:</p> <p>1. VF Mode</p>  <p>01:Password Decoder</p>  <table border="0"> <thead> <tr> <th style="text-align: left;">Items</th> <th style="text-align: left;">Description</th> </tr> </thead> <tbody> <tr><td>1.</td><td>Parameter Protection Password Input (Pr. 00-07)</td></tr> <tr><td>2.</td><td>Parameter Protection Password Setting (Pr. 00-08)</td></tr> <tr><td>3.</td><td>Control Mode (Pr. 00-10)</td></tr> <tr><td>4.</td><td>Control of Speed Mode (Pr. 00-11)</td></tr> <tr><td>5.</td><td>Load Selection (Pr. 00-16)</td></tr> <tr><td>6.</td><td>Carrier Frequency (Pr. 00-17)</td></tr> <tr><td>7.</td><td>Source of the Master Frequency Command (AUTO) (Pr. 00-20)</td></tr> <tr><td>8.</td><td>Source of the Operation Command (AUTO) (Pr. 00-21)</td></tr> <tr><td>9.</td><td>Stop Method (Pr. 00-22)</td></tr> <tr><td>10.</td><td>Digital Keypad STOP function (Pr.00-32)</td></tr> <tr><td>11.</td><td>Max. Operation Frequency (Pr. 01-00)</td></tr> <tr><td>12.</td><td>Base Frequency of Motor 1 (Pr. 01-01)</td></tr> <tr><td>13.</td><td>Max. Output Voltage Setting of Motor 1 (Pr. 01-02)</td></tr> <tr><td>14.</td><td>Middle Output Frequency of Motor 1 (Pr. 01-03)</td></tr> <tr><td>15.</td><td>Middle Output Voltage of Motor 1 (Pr. 01-04)</td></tr> <tr><td>16.</td><td>Middle Output Frequency of Motor 2 (Pr. 01-05)</td></tr> <tr><td>17.</td><td>Middle Output Voltage of Motor 2 (Pr. 01-06)</td></tr> <tr><td>18.</td><td>Min. Output Frequency of Motor 1 (Pr. 01-07)</td></tr> <tr><td>19.</td><td>Min. Output Voltage of Motor 1 (Pr. 01-08)</td></tr> <tr><td>20.</td><td>Output Frequency Upper Limit (Pr. 01-10)</td></tr> </tbody> </table>	Items	Description	1.	Parameter Protection Password Input (Pr. 00-07)	2.	Parameter Protection Password Setting (Pr. 00-08)	3.	Control Mode (Pr. 00-10)	4.	Control of Speed Mode (Pr. 00-11)	5.	Load Selection (Pr. 00-16)	6.	Carrier Frequency (Pr. 00-17)	7.	Source of the Master Frequency Command (AUTO) (Pr. 00-20)	8.	Source of the Operation Command (AUTO) (Pr. 00-21)	9.	Stop Method (Pr. 00-22)	10.	Digital Keypad STOP function (Pr.00-32)	11.	Max. Operation Frequency (Pr. 01-00)	12.	Base Frequency of Motor 1 (Pr. 01-01)	13.	Max. Output Voltage Setting of Motor 1 (Pr. 01-02)	14.	Middle Output Frequency of Motor 1 (Pr. 01-03)	15.	Middle Output Voltage of Motor 1 (Pr. 01-04)	16.	Middle Output Frequency of Motor 2 (Pr. 01-05)	17.	Middle Output Voltage of Motor 2 (Pr. 01-06)	18.	Min. Output Frequency of Motor 1 (Pr. 01-07)	19.	Min. Output Voltage of Motor 1 (Pr. 01-08)	20.	Output Frequency Upper Limit (Pr. 01-10)
Items	Description																																										
1.	Parameter Protection Password Input (Pr. 00-07)																																										
2.	Parameter Protection Password Setting (Pr. 00-08)																																										
3.	Control Mode (Pr. 00-10)																																										
4.	Control of Speed Mode (Pr. 00-11)																																										
5.	Load Selection (Pr. 00-16)																																										
6.	Carrier Frequency (Pr. 00-17)																																										
7.	Source of the Master Frequency Command (AUTO) (Pr. 00-20)																																										
8.	Source of the Operation Command (AUTO) (Pr. 00-21)																																										
9.	Stop Method (Pr. 00-22)																																										
10.	Digital Keypad STOP function (Pr.00-32)																																										
11.	Max. Operation Frequency (Pr. 01-00)																																										
12.	Base Frequency of Motor 1 (Pr. 01-01)																																										
13.	Max. Output Voltage Setting of Motor 1 (Pr. 01-02)																																										
14.	Middle Output Frequency of Motor 1 (Pr. 01-03)																																										
15.	Middle Output Voltage of Motor 1 (Pr. 01-04)																																										
16.	Middle Output Frequency of Motor 2 (Pr. 01-05)																																										
17.	Middle Output Voltage of Motor 2 (Pr. 01-06)																																										
18.	Min. Output Frequency of Motor 1 (Pr. 01-07)																																										
19.	Min. Output Voltage of Motor 1 (Pr. 01-08)																																										
20.	Output Frequency Upper Limit (Pr. 01-10)																																										

21. Output Frequency Lower Limit (Pr. 01-11)
22. Accel. Time 1 (Pr. 01-12)
23. Decel Time 1 (Pr. 01-13)
24. Over-voltage Stall Prevention (Pr. 06-01)
25. Derating protection (Pr. 06-55)
26. Software Brake Level (Pr. 07-00)
27. Speed tracking during start-up (Pr. 07-12)
28. Emergency stop (EF) & force to stop selection (Pr. 07-20)
29. Filter Time of Torque Command (Pr. 07-24)
30. Filter Time of Slip Compensation (Pr. 07-25)
31. Torque compensation gain (Pr. 07-26)
32. Slip Compensation Gain (Pr. 07-27)

## 2. VFPG Mode

VFPG Mode :P00-07  
 ↕01:Password De  
 02:Password Inp  
 03:Control Meth

01: Password Decoder

00-07  
 0  
 Password Decoder  
 0~65535

### Items

1. Parameter Protection Password Input (Pr. 00-07)
2. Parameter Protection Password Setting (Pr. 00-08)
3. Control Mode (Pr. 00-10)
4. Control of Speed Mode (Pr. 00-11)
5. Load Selection (Pr. 00-16)
6. Source of the Master Frequency Command (AUTO) (Pr. 00-20)
7. Source of the Operation Command (AUTO) (Pr. 00-21)
8. Stop Method (Pr. 00-22)
9. Digital Keypad STOP function (Pr. 00-32)
10. Max. Operation Frequency (Pr. 01-00)
11. Base Frequency of Motor 1 (Pr. 01-01)
12. Max. Output Voltage Setting of Motor 1 (Pr. 01-02)
13. Min. Output Frequency of Motor 1 (Pr. 01-07)
14. Min. Output Voltage of Motor 1 (Pr. 01-08)
15. Output Frequency Upper Limit (Pr. 01-10)
16. Output Frequency Lower Limit (Pr. 01-11)
17. Accel. Time 1 (Pr. 01-12)
18. Decel Time 1 (Pr. 01-13)
19. Over-voltage Stall Prevention (Pr. 06-01)
20. Software Brake Level (Pr. 07-00)
21. Filter Time of Torque Command (Pr. 07-24)
22. Filter Time of Slip Compensation (Pr. 07-25)
23. Slip Compensation Gain (Pr. 07-27)
24. Encoder Type Selection (Pr. 10-00)
25. Encoder Pulse (Pr. 10-01)
26. Encoder Input Type Setting (Pr. 10-02)
27. ASR Control ( P ) 1 (Pr. 11-06)
28. ASR Control (I) 1 (Pr. 11-07)
29. ASR Control ( P ) 2 (Pr. 11-08)
30. ASR Control (I) 2 (Pr. 11-09)
31. P Gain of Zero Speed (Pr. 11-10)
32. I Gain of Zero Speed (Pr. 11-11)

3. SVC Mode

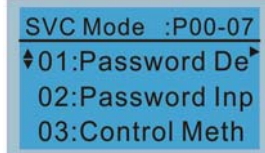

01: Password Decoder

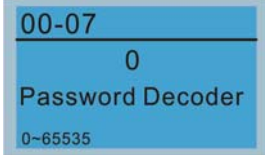

Items

1. Parameter Protection Password Input (Pr. 00-07)
2. Parameter Protection Password Setting (Pr. 00-08)
3. Control Mode (Pr. 00-10)
4. Control of Speed Mode (Pr. 00-11)
5. Load Selection (Pr. 00-16)
6. Carrier Frequency (Pr. 00-17)
7. Source of the Master Frequency Command (AUTO) (Pr. 00-20)
8. Source of the Operation Command (AUTO) (Pr. 00-21)
9. Stop Method (Pr. 00-22)
10. Digital Keypad STOP function (Pr. 00-32)
11. Max. Operation Frequency (Pr. 01-00)
12. Base Frequency of Motor 1 (Pr. P01-01)
13. Max. Output Voltage Setting of Motor 1 (Pr. 01-02)
14. Min. Output Frequency of Motor 1 (Pr. 01-07)
15. Min. Output Voltage of Motor 1 (Pr. 01-08)
16. Output Frequency Upper Limit (Pr. 01-10)
17. Output Frequency Lower Limit (Pr. 01-11)
18. Accel. Time 1 (Pr. 01-12)
19. Decel Time 1 (Pr. 01-13)
20. Full-load Current of Induction Motor 1 (Pr. 05-01)
21. Rated Power of Induction Motor 1 (Pr. 05-02)
22. Rated Speed of Induction Motor 1 (Pr. 05-03)
23. Pole Number of Induction Motor 1 (Pr. 05-04)
24. No-load Current of Induction Motor 1 (Pr. 05-05)
25. Over-voltage Stall Prevention (Pr. 06-01)
26. Over-current Stall Prevention during Acceleration (Pr. 06-03)
27. Derating Protection (Pr. 06-55)
28. Software Brake Level (Pr. 07-00)
29. Emergency Stop (EF) & Force to Stop Selection (Pr. 07-20)
30. Filter Time of Torque Command (Pr. 07-24)
31. Filter Time of Slip Compensation (Pr. 07-25)
32. Slip Compensation Gain (Pr. 07-27)

4. FOCPG Mode

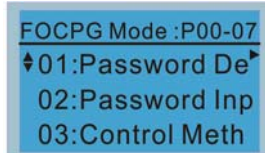

Items

1. Parameter Protection Password Input (Pr. 00-07)
2. Parameter Protection Password Setting (Pr. 00-08)
3. Control Mode (Pr. 00-10)
4. Control of Speed Mode (Pr. 00-11)

01: Password Decoder

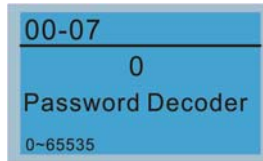

5. Source of the Master Frequency Command (AUTO) (Pr. 00-20)
6. Source of the Operation Command (AUTO) (Pr. 00-21)
7. Stop Method (Pr. 00-22)
8. Max. Operation Frequency (Pr. 01-00)
9. Base Frequency of Motor 1 (Pr. 01-01)
10. Max. Output Voltage Setting of Motor 1 (Pr. 01-02)
11. Output Frequency Upper Limit (Pr. 01-10)
12. Output Frequency Lower Limit (Pr. 01-11)
13. Accel. Time 1 (Pr. 01-12)
14. Decel Time 1 (Pr. 01-13)
15. Full-load Current of Induction Motor 1 (Pr. 05-01)
16. Rated Power of Induction Motor 1 (Pr. 05-02)
17. Rated Speed of Induction Motor 1 (Pr. 05-03)
18. Pole Number of Induction Motor 1 (Pr. 05-04)
19. No-load Current of Induction Motor 1 (Pr. 05-05)
20. Over-voltage Stall Prevention (Pr. 06-01)
21. Over-current Stall Prevention during Acceleration (Pr. 06-03)
22. Derating Protection (Pr. 06-55)
23. Software Brake Level (Pr. 07-00)
24. Emergency Stop (EF) & Force to Stop Selection (Pr. 07-20)
25. Encoder Type Selection (Pr. 10-00)
26. Encoder Pulse (Pr. 10-01)
27. Encoder Input Type Setting (Pr. 10-02)
28. System Control (Pr. 11-00)
29. Per Unit of System Inertia (Pr. 11-01)
30. ASR1 Low-speed Bandwidth (Pr. 11-03)
31. ASR2 High-speed Bandwidth (Pr. 11-04)
32. Zero-speed Bandwidth (Pr. 11-05)

5. TQCPG Mode

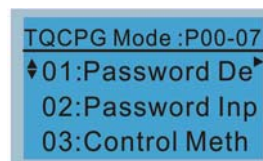

Items

01: Password Decoder

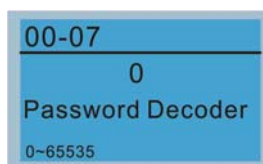

1. Password Input (Decode) (Pr. 00-07)
2. Password Setting (Pr. 00-08)
3. Control Mode (Pr. 00-10)
4. Control of Speed Mode (Pr. 00-11)
5. Source of the Master Frequency Command (Pr. 00-20)
6. Source of the Operation Command (Pr. 00-21)
7. Max. Operation Frequency (Pr. 01-00)
8. Base Frequency of Motor 1 (Pr. 01-01)
9. Max. Output Voltage Setting of Motor 1 (Pr. 01-02)
10. Full-load Current of Induction Motor 1 (Pr. 05-01)
11. Rated Power of Induction Motor 1 (Pr. 05-02)
12. Rated Speed of Induction Motor 1 (Pr. 05-03)



- 13. Pole Number of Induction Motor 1 (Pr. 05-04)
- 14. No-load Current of Induction Motor 1 (Pr. 05-05)
- 15. Over-voltage Stall Prevention (Pr. 06-01)
- 16. Software Brake Level (Pr. 07-00)
- 17. Encoder Type Selection (Pr. 10-00)
- 18. Encoder Pulse (Pr. 10-01)
- 19. Encoder Input Type Setting (Pr. 10-02)
- 20. System Control (Pr. 11-00)
- 21. Per Unit of System Inertia (Pr. 11-01)
- 22. ASR1 Low-speed Bandwidth (Pr. 11-03)
- 23. ASR2 High-speed Bandwidth (Pr. 11-04)
- 24. Zero-speed Bandwidth (Pr. 11-05)
- 25. Max. Torque Command (Pr. 11-27)
- 26. Source of Torque Offset (Pr. 11-28)
- 27. Torque Offset Setting (Pr. 11-29)
- 28. Source of Torque Command (Pr. 11-33)
- 29. Torque Command (Pr. 11-34)
- 30. Speed Limit Selection (Pr. 11-36)
- 31. Forward Speed Limit (torque mode) (Pr. 11-37)
- 32. Reverse Speed Limit (torque mode) (Pr. 11-38)

6. My Mode

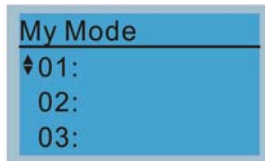

Click F4 in parameter setting page, the parameter will be saved to My Mode. To delete or correct the parameter, enter this parameter and click the "DEL" on the bottom right corner.

Items

It can save 01~32 sets of parameters (Pr).

Setup process

1. Go to "Parameter Setup" function. Press ENTER to go to the parameter which you need to use. There is an ADD on the bottom right-hand corner of the screen. Press F4 on the keypad to add this parameter to My Mode.

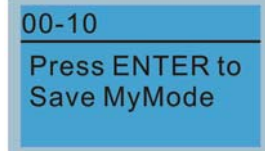
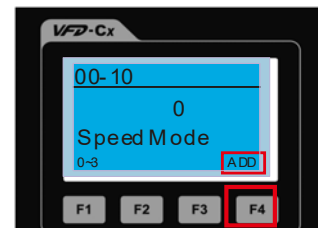

2. The parameter (Pr) will be displayed in My mode if it is properly saved. To correct or to delete this Pr., click DEL.

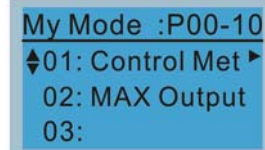

3. To delete a parameter, go to "My Mode" and select a parameter which you need to delete. Press ENTER to enter the parameter setting screen. There is a DEL on the

bottom left-hand corner of the screen. Press F4 on the keypad to delete this parameter from My Mode.

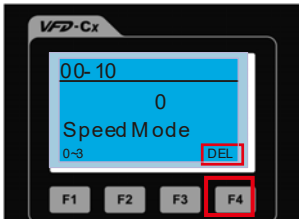
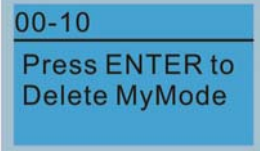
4. After pressing ENTER to delete <01 Control Mode>, the <02 Maximum Operating Frequency > will automatically replace <01 Control Mode>.



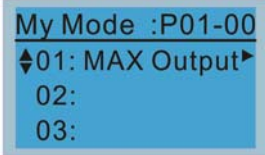

3. Application Selection List

This function allows user to select application and its parameters sets.

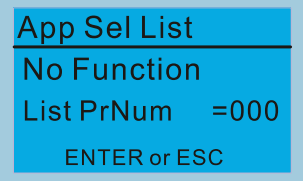
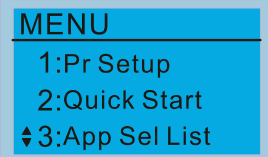
For example:  
Select 3: Application Selection List



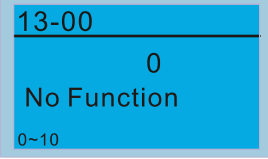

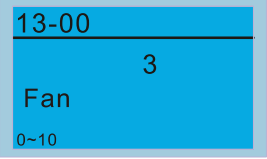
Press ENTER to go into the Application Selection List





Select Application

Press ENTER to enter the application selection screen, the selected application set will be "Fan".

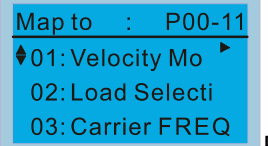

Press ENTER to enter the Fan application set screen.



Press Up/ Down key to select the parameter.





	<p>Map to : P00-11</p> <p>◆01: Velocity Mo ▶</p> <p>02: Load Selecti</p> <p>03: Carrier FREQ</p>	➔	<p>Map to : P07-33</p> <p>31: Momentary Po</p> <p>32: Auto Restart</p> <p>◆ 33: Reset Resta ▶</p>
	<p>00-16</p> <p>0</p> <p>Normal Duty</p> <p>0~1</p>		<p>Choose 0: Normal load or 1: Heavy load based on the needs, then press ENTER.</p>

4. Changed List

<p>Changed List</p> <p>Changed Pr</p> <p>List PrNum =026</p> <p>ENTER or ESC</p>	<p>This function displays the parameter that user has set.</p> <p>For example: Set Pr. 13-00 Application Selection = 3: Fan</p>			
	<table border="1" style="width: 100%;"> <tr> <td style="width: 50%;"> <p>13-00</p> <p>0</p> <p>No Function</p> <p>0~10</p> </td> <td style="width: 50%; text-align: center;">➔</td> <td style="width: 50%;"> <p>13-00</p> <p>3</p> <p>Fan</p> <p>0~10</p> </td> </tr> </table> <p>Enter the changed list screen. List PrNum=026 means there are 26 parameters that have been changed.</p>	<p>13-00</p> <p>0</p> <p>No Function</p> <p>0~10</p>	➔	<p>13-00</p> <p>3</p> <p>Fan</p> <p>0~10</p>
<p>13-00</p> <p>0</p> <p>No Function</p> <p>0~10</p>	➔	<p>13-00</p> <p>3</p> <p>Fan</p> <p>0~10</p>		
	<p>Changed List</p> <p>Changed Pr</p> <p>List PrNum =026</p> <p>ENTER or ESC</p> <p>Press ENTER to enter the changed list screen.</p>			
	<p>Map to : P00-17</p> <p>◆01: Carrier FREQ ▶</p> <p>02: Source of FR</p> <p>03: Source of OP</p> <p>Use Up/ Down key to select the parameters that need to be checked or changed.</p> <p>Press ENTER to enter the parameter.</p>			
	<p>00-17      KHz</p> <p>4</p> <p>Carrier FREQ</p> <p>2~15</p>			

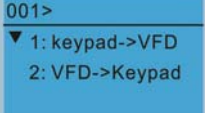
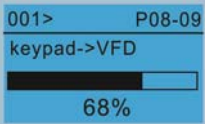
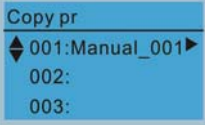
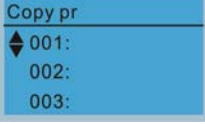
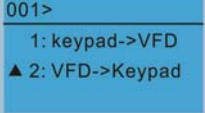

5. Copy Parameter

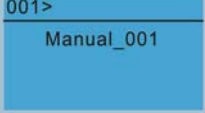
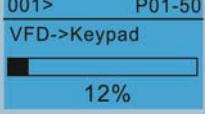
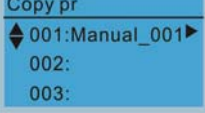
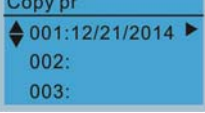
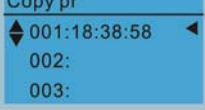
<p>Copy Pr</p> <p>◆ 001:Manual_001 ▶</p> <p>002:FileName01</p> <p>003:FileName02</p>	<p>4 duplicates are provided</p> <p>The steps are shown in the example below.</p> <p>Example: Saved in the motor drive.</p>		
<p>Press ENTER key to go to 001~004: content storage</p>	<table border="1" style="width: 100%;"> <tr> <td style="width: 50%;"> <p>Copy pr</p> <p>◆ 001:Manual_001 ▶</p> <p>002:</p> <p>003:</p> </td> <td style="width: 50%;"> <p>1 Go to "Copy Parameter"</p> <p>2 Select the parameter group which needs to be copied and press ENTER key.</p> </td> </tr> </table>	<p>Copy pr</p> <p>◆ 001:Manual_001 ▶</p> <p>002:</p> <p>003:</p>	<p>1 Go to "Copy Parameter"</p> <p>2 Select the parameter group which needs to be copied and press ENTER key.</p>
<p>Copy pr</p> <p>◆ 001:Manual_001 ▶</p> <p>002:</p> <p>003:</p>	<p>1 Go to "Copy Parameter"</p> <p>2 Select the parameter group which needs to be copied and press ENTER key.</p>		

  	<p>1. Select 1: Save in the motor drive. 2. Press ENTER key to go to “Save in the motor drive” screen.</p> <p>Begin to copy parameters until it is done.</p> <p>Once copying parameters is done, keypad will automatically go back to this screen.</p>
<p>Example: Saved in the keypad.</p>	
	<p>1. Go to “Copy parameter” 2. Select the parameter group which needs to be copied and press ENTER key.</p>
	<p>Press ENTER key to go to “Save in the motor drive” screen.</p>
	<p>Use Up/ Down key to select a symbol. Use Left/ Right key to move the cursor to select a file name.</p>
<p>String &amp; Symbol Table: ! " # \$ % &amp; ' ( ) * + , - . / 0 1 2 3 4 5 6 7 8 9 : ; &lt; = &gt; ? @ A B C D E F G H I J K L M N O P Q R S T U V W X Y Z [ \ ] ^ _ ` '  a b c d e f g h i j k l m n o p q r s t u v w x y z {   } ~</p>	
	<p>Once the file name is confirmed, press ENTER key.</p>
	<p>To begin copying parameters until it is done.</p>
	<p>When copying parameters is completed, keypad will automatically be back to this screen.</p>
	<p>Press Right key to see the date of copying parameters.</p>
	<p>Press Right key to see the time of copying parameters.</p>

6. Fault Record



	<p>Able to store 6 error codes (Keypad V1.02 and previous versions) Able to store 30 error codes (Keypad V1.20 and later version) The most recent error record is shown as the first record. Select an error record to see its details such as date, time, frequency, current, voltage, DCBUS voltage)</p>
---	--

<p>Press  to select.</p> <p>KPC-CE01 does not support this function.</p>	 <p><b>NOTE</b></p> <p>Fault actions of AC motor drive are recorded and saved to KPC-CC01. When KPC-CC01 is removed and applied to another AC motor drive, the previous fault records will not be deleted. The new fault records of the present AC motor drive will accumulate to KPC-CC01.</p>	<p>Press Up/ Down key to select an error record. After selecting an error code, press ENTER to see that error record's detail</p> <p>Press Up/ Down key to see an error record's detail such as date, time, frequency, current, voltage, DCBUS voltage.</p> <p>Press Up/ Down key to select an error record. After selecting an error code, press ENTER to see that error record's detail</p> <p>Press Up/ Down key to see an error record's detail such as date, time, frequency, current, voltage, DCBUS voltage.</p>
---	--	---

7. Language Setup

 <p>Use Up / Down key to select language, than press ENTER.</p>	<p>Language setting option is displayed in the language of the user's choice. Language setting options:</p> <table border="0"> <tr> <td>1. English</td> <td>5. Русский</td> </tr> <tr> <td>2. 繁體中文</td> <td>6. Español</td> </tr> <tr> <td>3. 简体中文</td> <td>7. Português</td> </tr> <tr> <td>4. Türkçe</td> <td>8. français</td> </tr> </table>	1. English	5. Русский	2. 繁體中文	6. Español	3. 简体中文	7. Português	4. Türkçe	8. français
1. English	5. Русский								
2. 繁體中文	6. Español								
3. 简体中文	7. Português								
4. Türkçe	8. français								

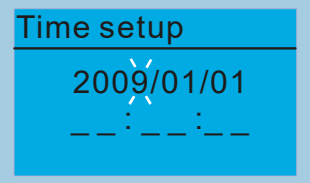
8. Time Setup

 <p>Use Left / Right key to select Year, Month, Day, Hour, Minute or Second to set up</p>		<p>Use Up / Down key to set up Year</p> <p>Use Up / Down key to set up Month</p> <p>Use Up / Down key to set up Day</p>
--	---	---



	<p>Use Up / Down key to set up Hour</p>
	<p>Use Up / Down key to set up Minute</p>
	<p>Use Up / Down key to set up Second</p>
	<p>After setting up, press ENTER to confirm the setup.</p>

**NOTE**  
 Limitation: The charging process of the super capacitor will finish in about 6 minutes. **When the digital keypad is removed, the time setting will be in standby status for 7 days.** After this period, the time needs to be reset.

9. Keypad Locked

	<p>Keypad Locked</p> <p>This function is used to lock the keypad. The main page would not display "keypad locked" when the keypad is locked, however it will display the message "please press ESC and then ENTER to unlock the keypad" when any key is pressed.</p>
<p>Press  to lock</p>	<p>When the keypad is locked, the main screen doesn't display any status to show that.</p>
	<p>Press any key on the keypad; a screen as shown in image on the left will be displayed.</p>
	<p>If ESC key is not pressed, the keypad will automatically be back to this screen.</p>
	<p>The keypad is still locked at this moment. By pressing any key, a screen as shown in the image on the left will still be displayed.</p>
	<p>Press ESC for 3 seconds to unlock the keypad and the keypad will be back to this screen. Then each key on the keypad is functional.</p>
	<p>After the above steps, the keypad will not be locked when turning off the power and turning on the power again.</p>

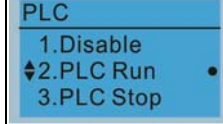
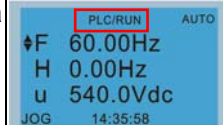
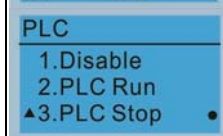
10. PLC Function

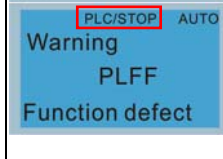
	<p>When the PLC function is activated or stopped, the PLC status will be displayed on main page of Delta default setting.</p>
<p>Press Up/Down key to select a PLC's function. Then press ENTER.</p>	 <p>Option 2: Enable PLC function</p>
	 <p>Factory setting on the main screen displays PLC/RUN status bar.</p>
	 <p>Option 3: Disable PLC function</p>
	 <p>Factory setting on the main screen displays PLC/STOP status bar</p>
	 <p>If the PLC program is not available in the control board, PLFF warning will be displayed when choosing option 2 or 3. In this case, select option 1: No Function to clear PLFF warning.</p>
	<p>The PLC function of KPC-CE01 can only displays:</p> <ol style="list-style-type: none"> <li>1. PLC0</li> <li>2. PLC1</li> <li>3. PLC2</li> </ol>

11. Copy PLC

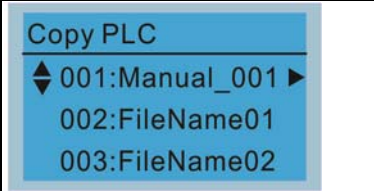
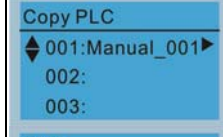
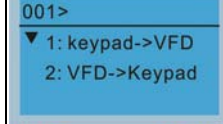
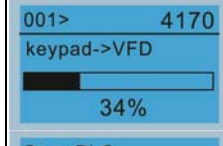
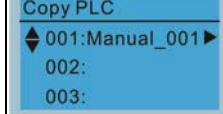
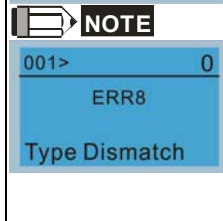
	<p>4 duplicates are provided</p>
	<p>The steps are shown in the example below.</p>
	<p>Example: Saved in the motor drive.</p>
	 <ol style="list-style-type: none"> <li>1. Go to "Copy PLC"</li> <li>2. Select a parameter group to copy, then press ENTER.</li> </ol>
	 <ol style="list-style-type: none"> <li>1. Select 1: Save in the motor drive.</li> <li>2. Press ENTER key to go to "Save in the motor drive" screen.</li> </ol>
	 <p>Begin to copy PLC until it is done.</p>
	 <p>Once copying PLC is done, keypad will automatically be back to this screen.</p>
	<p><b>NOTE</b></p>  <p>If "Option 1: Save in the motor drive" is selected, verify if the PLC program is built-in to KPC-CC01 keypad. If PLC program is not available in the keypad while "Option 1: Save in the motor drive" is selected, an "ERR8 Warning: Type not matching" will be displayed on the screen.</p>

	<p>Unplug and plug back the keypad while copying the PLC program will cause a CPLt warning.</p>
<p>Example: Saved in the keypad.</p>	
	<ol style="list-style-type: none"> <li>1. Go to "Copy PLC".</li> <li>2. Select the parameter group which needs to be copied and press ENTER key.</li> </ol>
	<p>Press ENTER key to go to "Save in the motor drive" screen.</p>
	<p>If WPLSoft editor is installed and password is set, enter the password to save the file onto digital display.</p>
	<p>Use Up/ Down key to select a symbol. Use Left/ Right key to move the cursor to select a file name.</p>
<p><b>String &amp; Symbol Table:</b> !"#\$%&amp;'()*+,-./0123456789:;&lt;=&gt;?@A BCDEFGHIJKLMNOPQRSTUVWXYZ[\]^_`a b c d f g h i j k l m n o p q r s t u v w x y z {   } ~</p>	
	<p>Once the file name is confirmed, press ENTER key.</p>
	<p>To begin copying parameters until it is done.</p>
	<p>When copying parameters is completed, keypad will automatically be back to this screen.</p>
	<p>Press Right key to see the date of copying parameters.</p>
	<p>Press Right key to see the time of copying parameters.</p>

12. Display setup

	<p>1. Contrast</p>	<p>Use Up / Down key to adjust the setting value.</p>
--	--------------------	---



Press  to setting menu.



After selecting a setting value. Press ENTER to see screen's display after contrast is adjusted to be +10.



When the setting value is 0 Min, the backlight will be steady on.



Then press ENTER.



After select a setting value Press ENTER to see screen's display result after contrast is adjusted to be -10.

### 2. Back-light



Press ENTER to go to "Back Light Time Setting" screen.

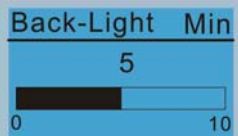

Use Up / Down key to adjust the setting value.

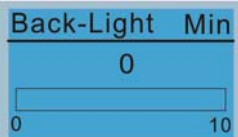

When the setting value is 0 Min, the backlight will be steady on.



When the setting value is 10 Min, the backlight will be off in 10 minutes.

### 3. Text Color

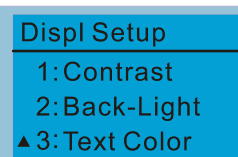

Press ENTER to go to Text Color Setting screen.

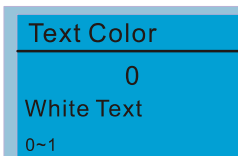

The default value is White Text.

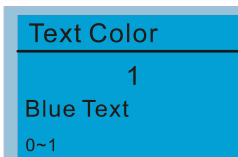



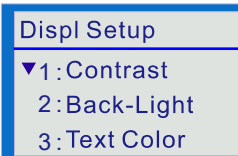

Use Up / Down key to adjust the setting value.

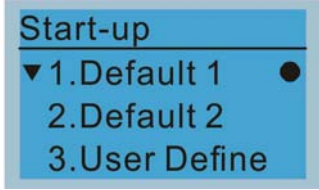

The setting value changes to Blue Text.

13. Start-up

	<p>1. Default 1 DELTA LOGO</p>  <p>2. Default 2 DELTA Text</p>  <p>3. User Defined: optional accessory is required (TPEditor &amp; USB / RS-485 Communication Interface-IFD6530) Install an editing accessory would allow users to design their own start-up page. If editor accessory is not installed, "user defined" option will display a blank page.</p>  <p><u>USB/RS-485 Communication Interface-IFD6530</u> Please refer to Chapter 07 Optional Accessories for more detail.</p> <p><u>TPEditor</u> Go to Delta's website to download TPEditor V1.60 or later versions. <a href="http://www.deltaww.com/services/DownloadCenter2.aspx?seclD=8&amp;pid=2&amp;tid=0&amp;CID=06&amp;itemID=060302&amp;typeID=1&amp;dowloadID=&amp;title=-- Select Product Series --&amp;dataType=8;&amp;check=1&amp;hl=en-US">http://www.deltaww.com/services/DownloadCenter2.aspx?seclD=8&amp;pid=2&amp;tid=0&amp;CID=06&amp;itemID=060302&amp;typeID=1&amp;dowloadID=&amp;title=-- Select Product Series --&amp;dataType=8;&amp;check=1&amp;hl=en-US</a></p>
---	--

14. Main page

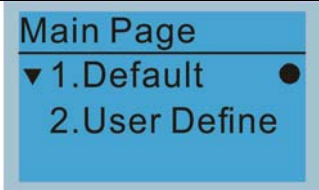
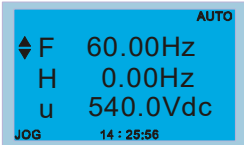
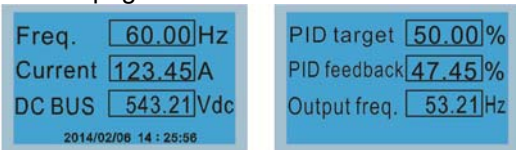
	<p>1. Default page</p>  <p>F 60.00Hz &gt;&gt;&gt; H &gt;&gt;&gt; A &gt;&gt;&gt; U (circulate)</p> <p>2. User Defined: optional accessory is required (TPEditor &amp; USB / RS-485 Communication Interface-IFD6530) Install an editing accessory would allow users to design their own main page. If editor accessory is not installed, "user defined" option will display a blank page.</p>  <p><u>USB/RS-485 Communication Interface-IFD6530</u> Please refer to Chapter 07 Optional Accessories for more detail.</p> <p><u>TPEditor</u> Go to Delta's website to download TPEditor V1.60 or later versions. <a href="http://www.deltaww.com/services/DownloadCenter2.aspx?seclD=8&amp;pid=2&amp;tid=0&amp;CID=06&amp;itemID=060302&amp;typeID=1&amp;dowloadID=&amp;title=-- Select Product Series --&amp;dataType=8;&amp;check=1&amp;hl=en-US">http://www.deltaww.com/services/DownloadCenter2.aspx?seclD=8&amp;pid=2&amp;tid=0&amp;CID=06&amp;itemID=060302&amp;typeID=1&amp;dowloadID=&amp;title=-- Select Product Series --&amp;dataType=8;&amp;check=1&amp;hl=en-US</a></p>
---	--

Default picture and editable picture are available upon selection.

Press  to select.



15. PC Link

PC Link  
 ▼1. TPEditor  
 2. VFDSOft

1. TPEditor: This function allows users to connect the keypad to a computer then to download and edit user defined pages.

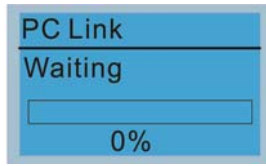

Click ENTER to go to <Waiting to connect to PC>

In TPEditor, choose <Communication>, then choose “Write to HMI”

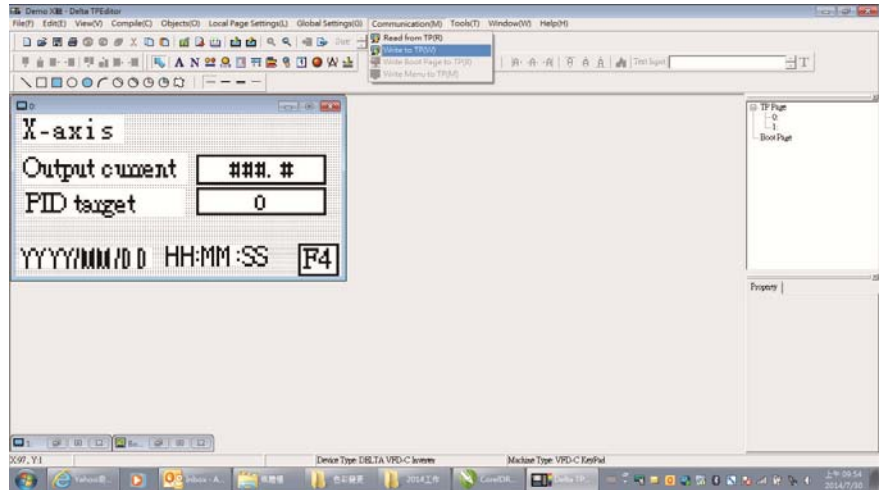

Choose <YES> in the <Confirm to Write> dialogue box.

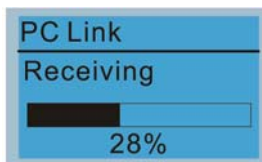
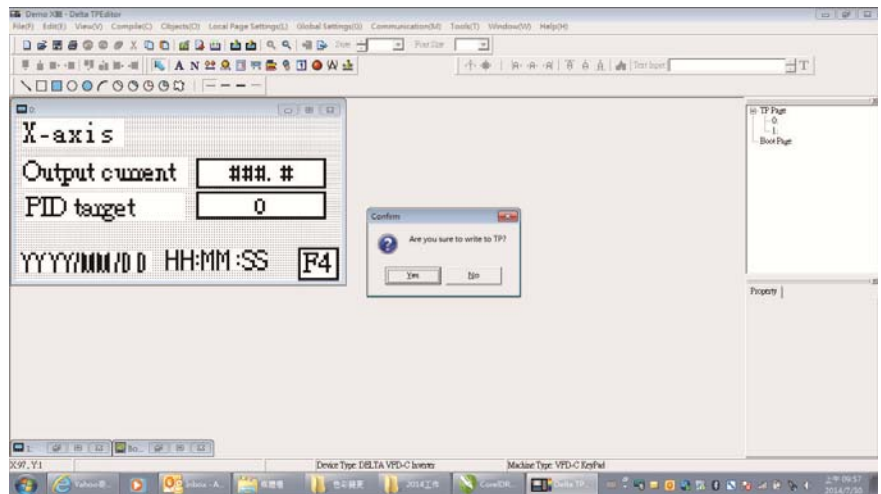

Start downloading pages to edit KPC-CC01.

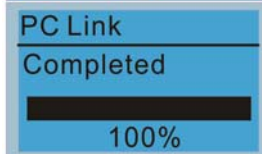

Download completed

2. VFDSOft: this function allows user to link to the VFDSOft Operating software then to upload data.  
 Copy parameter 1~4 in KPC-CC01  
**NOTE** When the Operation System (OS) of your computer is Windows 10, right click on the icon of VFDSOft to enter <Property> (as shown in the red color square in the image below). Then click on the <Compatibility> tab and select the <Run this program as an administrator.> (also as shown in the red color square in the image below)

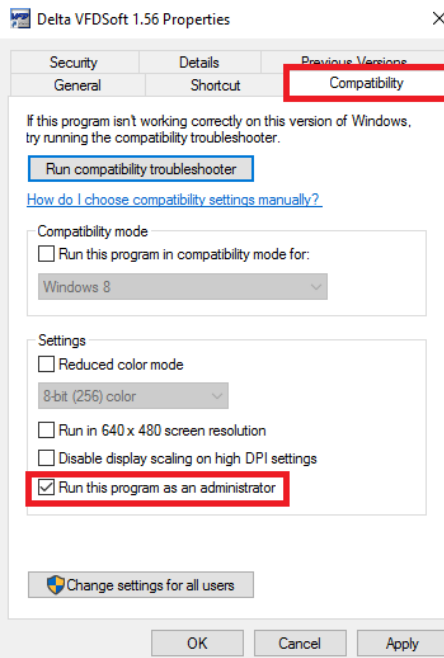

Connect KPC-CC01 to a computer

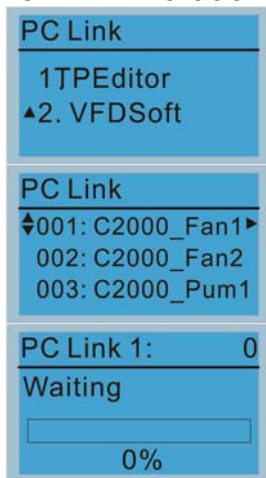

Start downloading pages to edit to KPC-CC01

Use Up / Down key to select a parameter group to upload to VFDSOft. Press ENTER

Waiting to connect to PC

Open VFDSOft, choose <Parameter Manager function>

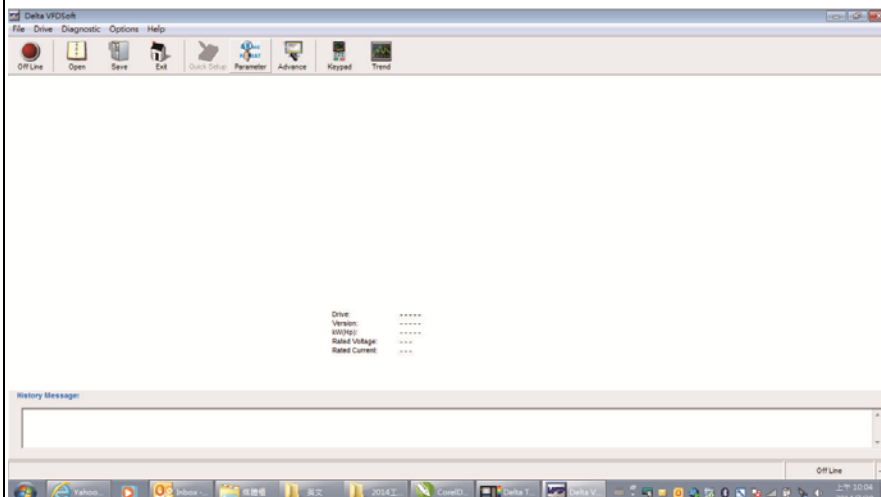

In Parameter Manager, choose <Load parameter table from KPC-CC01>

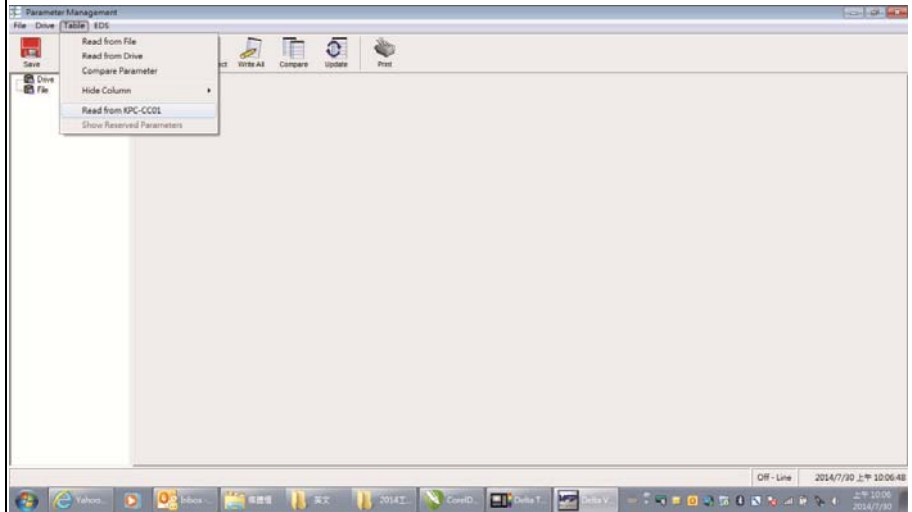

Choose the right communication port and click OK

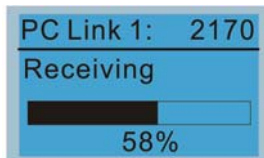
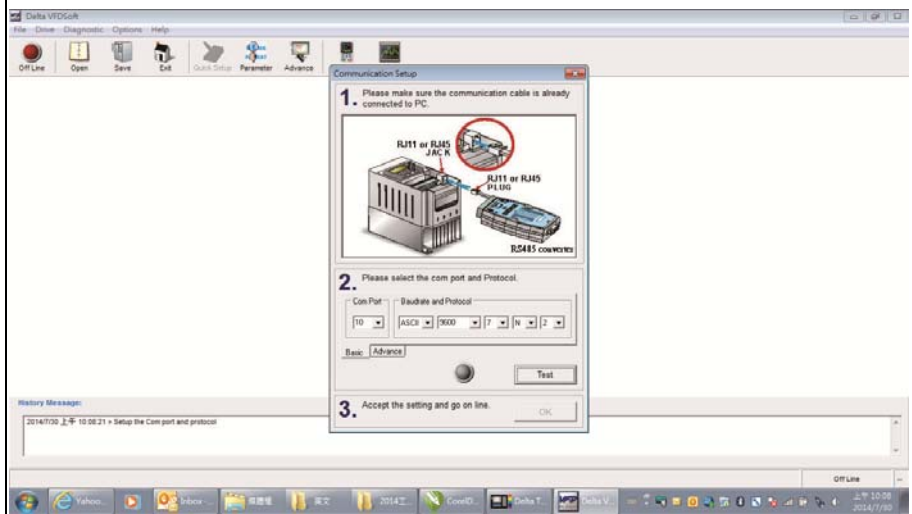

Start to upload parameters to VFDSOft

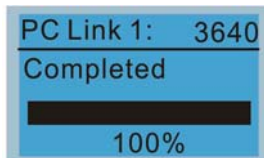

Uploading parameter is completed

Before using the user defined starting screen and user defined main screen, the starting screen setup and the main screen setup have to be preset as user defined.  
If the user defined page are not downloaded to KPC-CC01, the starting screen and the main screen will be blank.

16. Start Wizard

F1 : Next ; F1 : Back

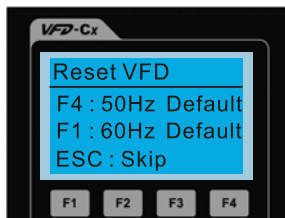

F1  
F1



F4



NOTE: The Start Wizard will not show up when re-power next time.

MENU



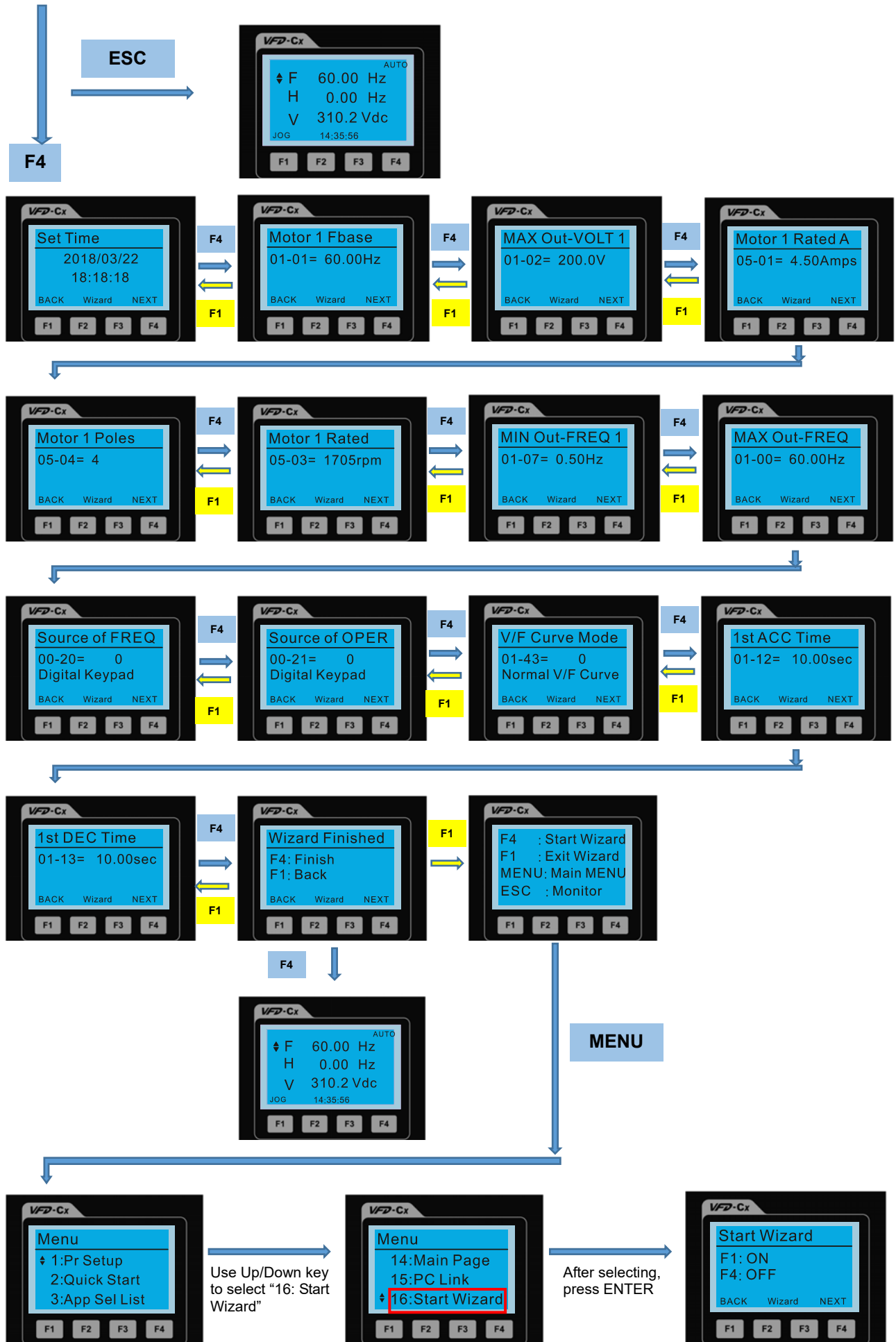

NOTE: The “16: Start Wizard” on the menu is to set whether shows start wizard when start up the drive.

## Other display

When a fault occurs, the menu will display:

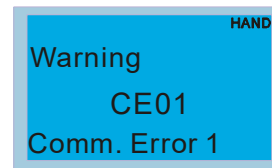
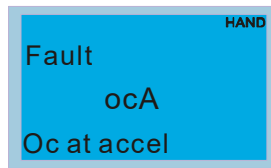

1. Press STOP / RESET button to reset the fault code. If still no response, please contact local distributor or return to the factory. To view the fault DCBUS voltage, output current and output voltage, press "MENU"→"Fault Record".
2. After resetting, if the screen returns to main page and shows no fault after pressing ESC, the fault is cleared.
3. When fault or warning message appears, backlight LED will blink until the fault or the warning is cleared.

## Optional accessory: RJ45 Extension Lead for Digital Keypad

Part No.	Description
CBC-K3FT	RJ45 extension lead, 3 feet (approximately 0.9m)
CBC-K5FT	RJ45 extension lead, 5 feet (approximately 1.5 m)
CBC-K7FT	RJ45 extension lead, 7 feet (approximately 2.1 m)
CBC-K10FT	RJ45 extension lead, 10 feet (approximately 3 m)
CBC-K16FT	RJ45 extension lead, 16 feet (approximately 4.9 m)

Note: When you need to buy communication cables, buy non-shielded, 24 AWG, 4 twisted pair, 100 ohms communication cables.

## 10-3 TPEditor Installation Instruction

TPEditor can edit up to 256 HMI (Human-Machine Interface) pages with a total storage capacity of 256KB. Each page can edit 50 normal objects and 10 communication objects.

### 1) TPEditor: Setup & Basic Functions

1. Run TPEditor version 1.60 or above



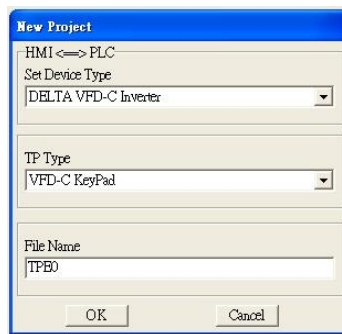

2. Go to File (F) → Click on New. The Window below will pop up. At the device type, click on the drop down menu and choose DELTA VFD-C Inverter. At the TP type, click on the drop down menu and choose VFD-C KeyPad. As for File Name, enter TPE0. Now click on OK.



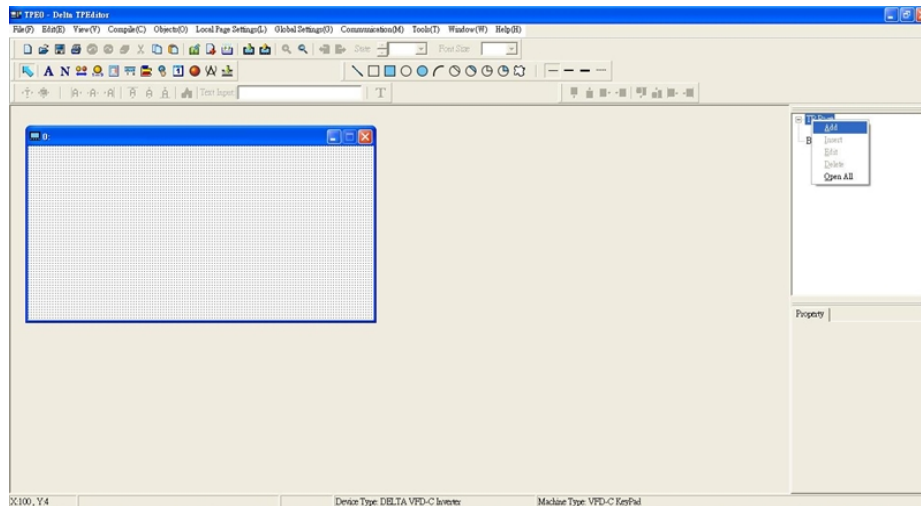

3. You are now at the designing page. Go to Edit (E) → Click on Add a New Page (A) or go to the TP page on the upper right side, right click once on TP page and choose Add to increase one more page for editing.

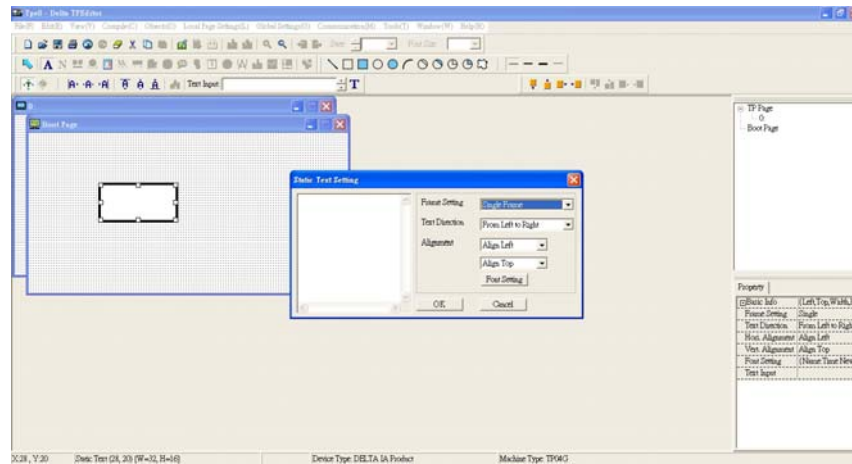

4. Edit Startup Page

- Static Text  . Open a blank page, click once on this button  , and then double click on that blank page. The following window will pop up.



- Static Bitmap  → Open a blank page, then click once on this button  and then double click on that blank page. The following window will pop up.

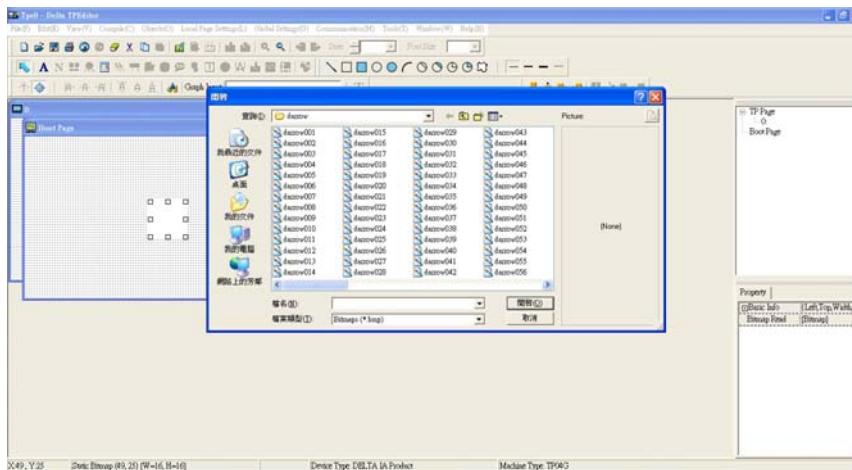

Please note that Static Bitmap setting supports only images in BMP format. Now choose an image that you need and click open, then that image will appear in the Static Bitmap window.

- Geometric Bitmap  → As shown in the picture on the left, there are 11 kinds of geometric bitmap to choose. Open a new blank page then click once on a geometric bitmap icon that you need. Then drag that icon and enlarge it to the size that you need on that blank page.
- Finish editing the keypad starting screen and select **Communication>Input User Defined Keypad Starting Screen.**

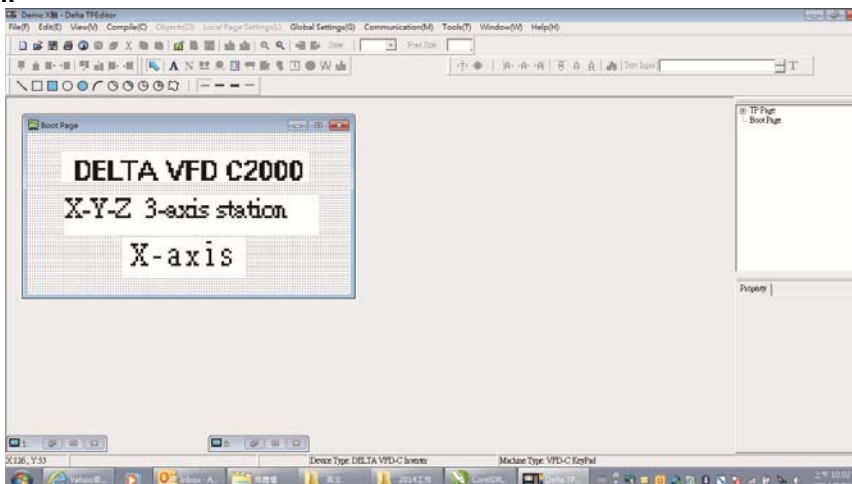



- 9. Downloading setting: Go to Tool > Communication. Set up communication port and speed of IFD6530.
- 10. Only three speed selections are available: 9600 bps, 19200 bps and 38400 bps.

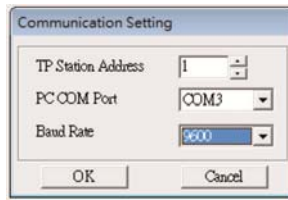

- 11. When a dialogue box displayed on the screen asking to confirm writing or not, press buttons on the keypad to go to MENU, select PC LINK and then press ENTER and wait for few seconds. Then select YES on the screen to start downloading.

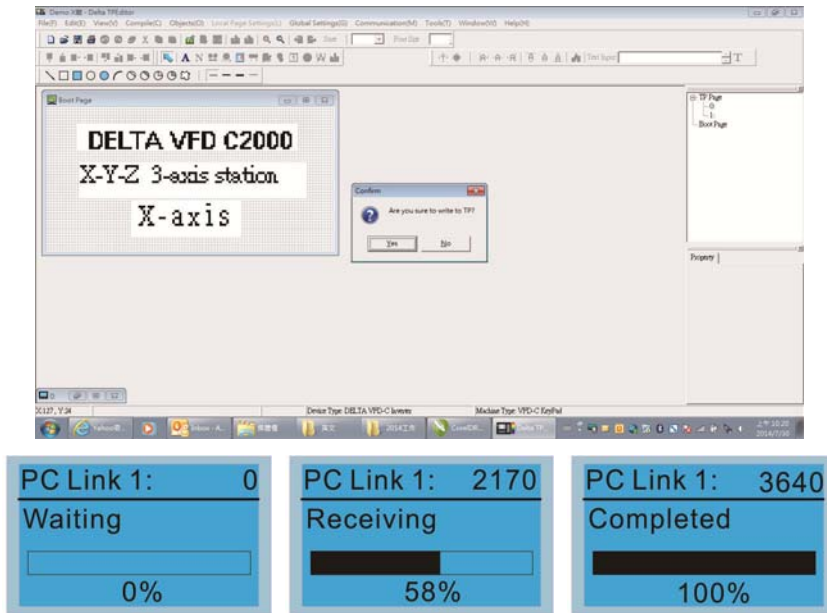

2) Edit Main Page & Example of Download

1. Go to editing page, select Edit > Add one page or press the button ADD on the right hand side of the HMI page to increase number of pages to edit. This keypad currently supports up to 256 pages.

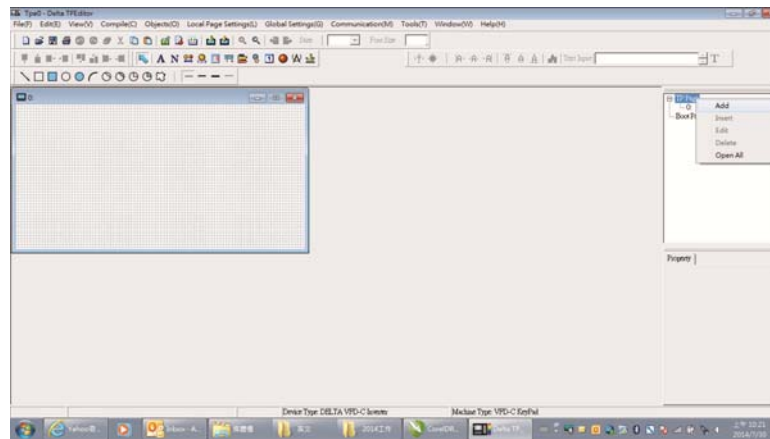

2. On the bottom right-hand corner of the HMI, click on a page number to edit or go to VIEW > HMI page to start editing main page. As shown in the image, the following objects are available. From left to right: Static Text, ASCII Display, Static Bitmap, Scale, Bar Graph, Button, Clock Display, Multi-state bit map, Units, Numeric Input and 11 geometric bitmaps and lines of different width. The application of Static Text, Static Bitmap, and geometric bitmap is the same as the editing startup page.



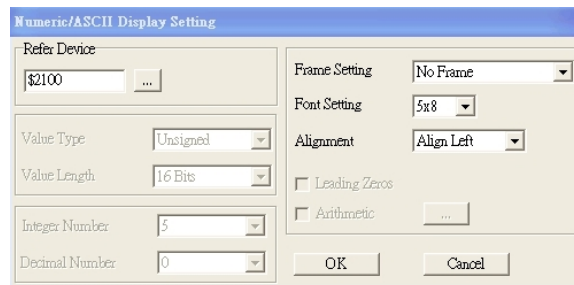

3. Numeric / ASCII Display: To add a Numeric / ASCII Display object to a screen, double click on the object to set up Related Devices, Frame Setting, Fonts and Alignment.



Related Device: Choose the VFD Communication Port that you need, if you want to read output frequency (H), set the VFD Communication Port to \$2202. For other values, please refer to ACMD ModBus Comm Address List.



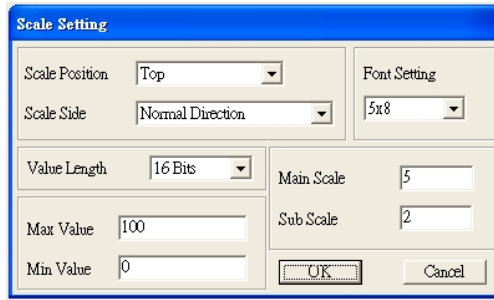

4. Scale Setting  : On the Tool Bar, click on  for Scale Setting. You can also edit Scale Setting in the Property Window on the right hand side of your computer screen.

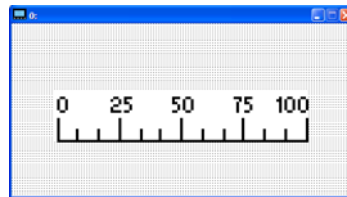

- Scale Position: Click on the drop down list to choose which position that you need to place a scale.
- Scale Side: Click on the drop down list to choose if you want to number your scale from smaller number to bigger number or from big to small. Click OK to accept this setting or click Cancel to abort.
- Font Setting: Click on the drop down list to choose the Font setting that you need then click OK to accept the setting or click Cancel to abort.
- Value Length: Click on the drop down to choose 16 bits or 32 bits. Then click OK to accept the setting or click Cancel to abort.
- Main Scale & Sub Scale: In order to divide the whole scale into equal parts, key in the numbers of your choices for main scale and sub scale.
- Maximum value & Minimum Value are the numbers on the two ends of a scale. They can be negative numbers. But the values allowed to be input are limited by the length of value. For example, when the length of value is set to **be hexadecimal**, the maximum and the minimum value cannot be input as -4000.

Follow the Scale setting mentioned above; you will have a scale as shown below.



5. Bar Graph setting  :

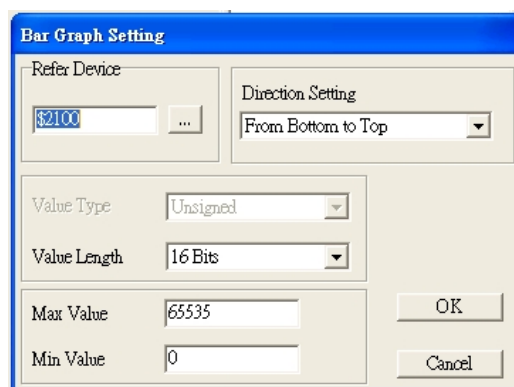

- Related Device: Choose the VFD Communication Port that you need.
- Direction Setting: Click on the drop down menu to choose one of the following directions: From Bottom to Top, From Top to Bottom, From Left to Right or From Right to Left.
- Maximum Value & Minimum Value: They define the range covered by the maximum value and minimum value. If a value is smaller than or equal to the minimum value, then the bar graph will be blank. If a value is bigger or equal to the maximum value, then the bar graph will be full. If a value is between minimum and maximum value, then the bar graph will be filled proportionally.

6. Button : Currently this function only allows the Keypad to switch pages, other functions are not yet available. Text input function and Image inserted functions are not yet supported.

Double click on  to open set up window.

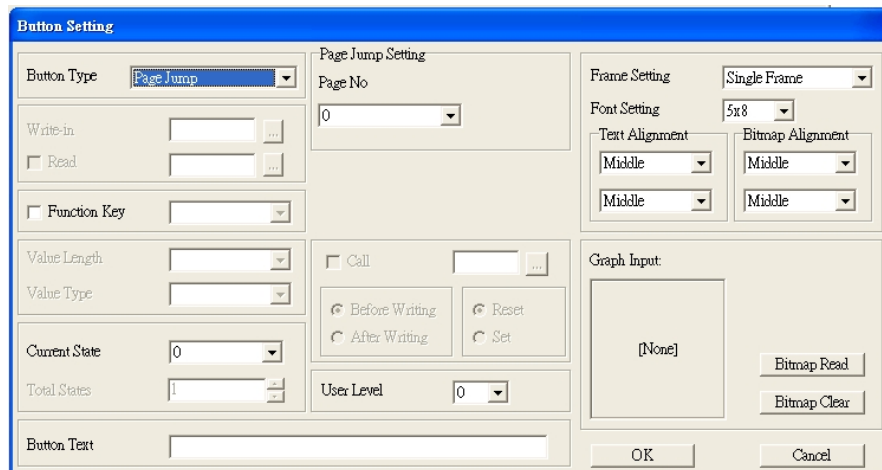

<Button Type> allows users set up buttons' functions. <Page Jump> and <Constant Setting> are the only two currently supported functions.

#### A. [Page Jump] function setting

- Page Jump setting: After you choose the Page Jump function in the drop down list, you will see this Page Jump Setting Menu
- <Function Key> allows you to assign functions to the following keys on the KPC-CC01 keypad: F1, F2, F3, F4, Up, Down, Left and Right. Please note that the Up and Down keys are locked by TPEditor. These two keys cannot be programmed. If you want to program Up and Down keys, go to Tool→Function Key Settings (F) →Re-Define Up / Down Key (R).

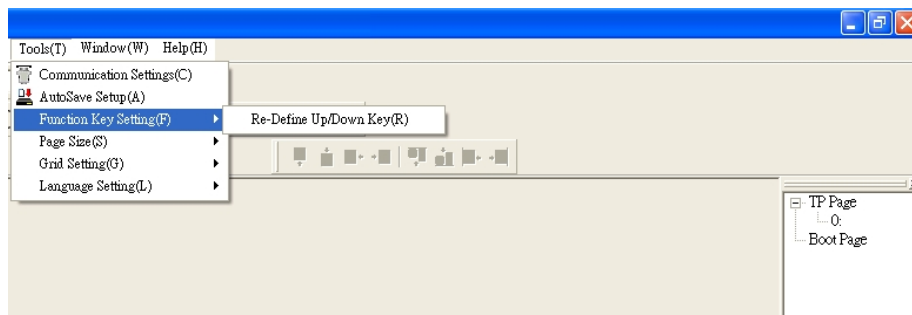

- Button Text: This function allows user to name buttons. For example, key in <Next Page> in the empty space, a button will have the wording <Next Page> displayed on it.

#### B. [Constant setting] function

This function is to set up the memory address' value of the VFD or PLC. When pressing the <function button> set up in before, a value will be written to the memory address of the <Constant Setting>. This function can be used as initializing a variable.

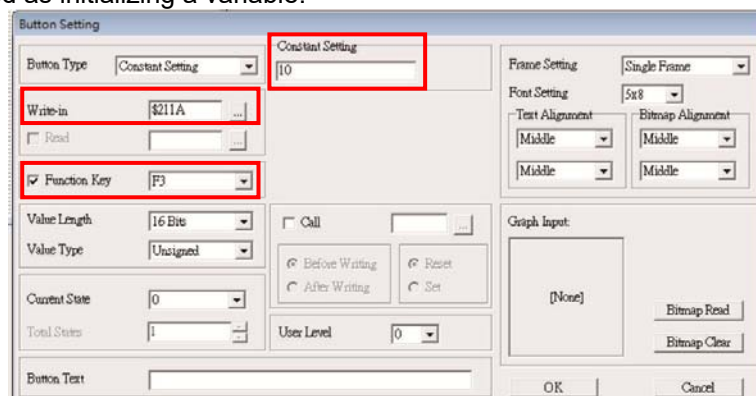

7. Clock Display Setting  : The setup window of the Clock Display is shown as the image below. Time, Day or Date can be displayed on the keypad.  
 Open a new file and click once in that window, you will see the following  
 In the clock display setting, you can choose to display Time, Day or Date on the Keypad. To adjust time, go to #9 on the Keypad's menu. You can also adjust Frame Setting, Font Setting and Alignment.

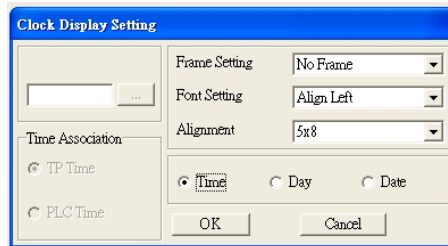

8. Multi-state bitmap  : The setup window of the multi-state is shown as the image below. This object reads the bit's property value of the PLC. It defines what image or wording is when this bit is 0 or when this bit is 1. Set the initial status to be 0 or 1 to define the displayed image or wording.

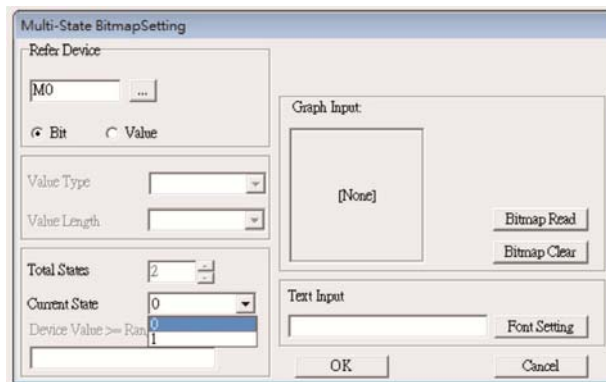

9. Unit Measurement  : Click once on this Button  
 Open a new file and double click on that window, you will see the following:

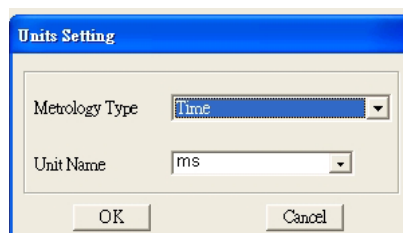

Choose from the drop down list the Metrology and the Unity Name that you need. As for Metrology, you have the following choices: Length, Square Measure, Volume/Solid Measure, Weight, Speed, Time and Temperature. The unit name changes automatically when you change metrology type.

## 10. Numeric Input Setting

This menu allows you to provide parameters or communication ports and to input numbers.

Click once on this button .

Open a new file and double click on that window, you will see the following:

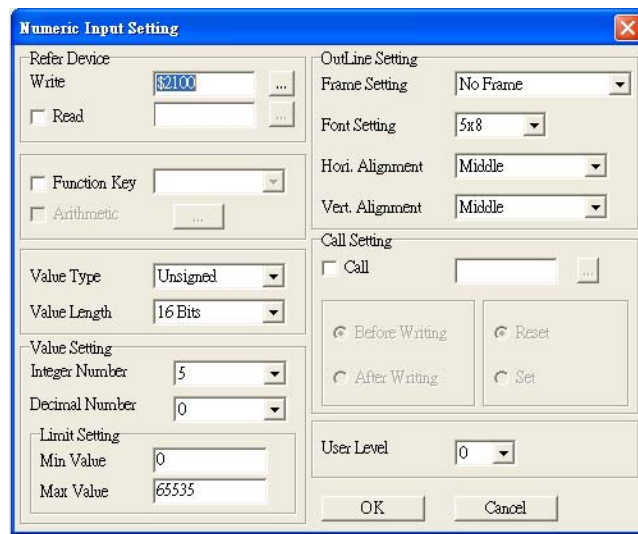

- Related Device:** There are two blank spaces to fill in, one is <Write> and another one is <Read>. Input the numbers that you want to display and the corresponding numbers of a parameter and that of a communication port. For example, input 012C to Read and Write Parameter Pr. 01-44.
- Outline Setting:** The Frame setting, Font setting, Vertical Alignment and Horizontal Alignment are the same as mentioned before. Click on the drop down menu and choose the setting that you need.
- Function key:** The setting here allows you to program keys on the keypad. Press the key on the menu then the corresponding key on the keypad will start to blink, then press Enter to confirm the setting.
- Value Type & Value Length:** These two factors influence the range of the Minimum and Maximum Value of the Limit Setting. Please note that the corresponding supporting values for C2000 have to be 16bits. The 32bits values are not supported.
- Value Setting:** This part is set automatically by the keypad itself.
- Limit Setting:** Input the range the security setting here.

For example, if you set Function Key as F1, Minimum Value as 0 and Maximum Value as 4, then press F1 on Keypad. Then you can press Up and Down key on the keypad to increase or decrease the value. Press Enter Key on the keypad to confirm your setting. You can also go to parameter table 01-44 to verify if your input value is correct.

- Download TP Page:** Press Up or Down key on the keypad until you reach #13 PC Link. Then press Enter on the keypad and you will see the word "Waiting" on keypad's screen. Now choose a page that you have created then go to Communication (M) → Write to TP (W) to start downloading the page to the keypad. When you see the word Completed on the keypad's screen, that means the download is done. Then you can press ESC on the keypad to go back to the menu of the keypad.

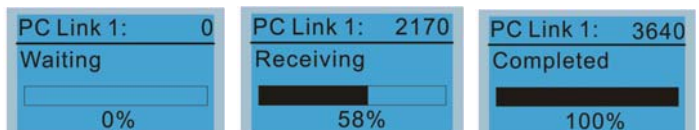
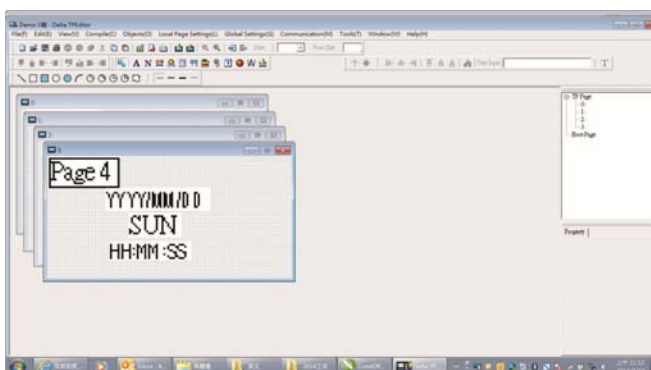

## 10-4 Digital Keypad KPC-CC01 Fault Codes and Descriptions

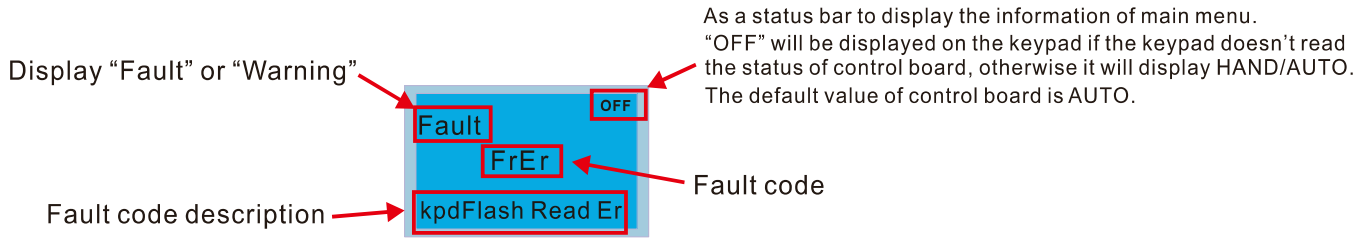



### Fault Codes

LCM Display *	Description	Corrective Actions
	Keypad flash memory read error	An error has occurred on keypad's flash memory. <ol style="list-style-type: none"> <li>1. Press RESET on the keypad to clear errors.</li> <li>2. Verify if there's any problem on Flash IC.</li> <li>3. Shut down the system, wait for ten minutes, and then power on again the system.</li> </ol> If none of the solution above works, contact your authorized local dealer.
	Keypad flash memory save error	An error has occurred on keypad's flash memory. <ol style="list-style-type: none"> <li>1. Press RESET on the keypad to clear errors.</li> <li>2. Verify if there's any problem on Flash IC.</li> <li>3. Shut down the system, wait for ten minutes, and then power on again the system.</li> </ol> If none of the solution above works, contact your authorized local dealer.
	Keypad flash memory parameter error	Errors occurred on factory setting of parameters. It might be caused by firmware update. <ol style="list-style-type: none"> <li>1. Press RESET on the keypad to clear errors.</li> <li>2. Verify if there's any problem on Flash IC.</li> <li>3. Shut down the system, wait for ten minutes, and then power on again the system.</li> </ol> If none of the solution above works, contact your local authorized dealer.
	Keypad flash memory when read AC drive data error	Keypad cannot read any data sent from VFD. <ol style="list-style-type: none"> <li>1. Verify if the keypad is properly connected to the motor drive by a communication cable such as RJ-45.</li> <li>2. Press RESET on the keypad to clear errors.</li> <li>3. Shut down the system, wait for ten minutes, and then power on again the system.</li> </ol> If none of the solution above works, contact your local authorized dealer.
	A serious CPU error occurs to the Keypad	A Serious error has occurred on keypad's CPU. <ol style="list-style-type: none"> <li>1. Verify if there's any problem on CPU clock?</li> <li>2. Verify if there's any problem on Flash IC?</li> <li>3. Verify if there's any problem on RTC IC?</li> <li>4. Verify if the communication quality of the RS485 is good?</li> <li>5. Shut down the system, wait for ten minutes, and then power on again the system. If none of the solution above works, contact your local authorized dealer.</li> </ol>

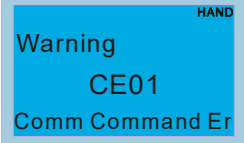
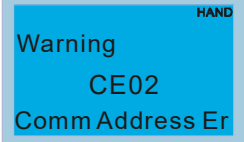
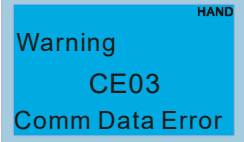
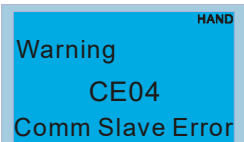
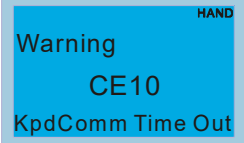
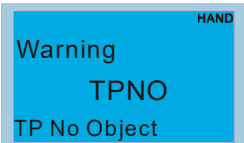

## Warning Codes

LCM Display *	Description	Corrective Actions
	Modbus function code error	Motor drive doesn't accept the communication command sent from keypad. 1. Verify if the keypad is properly connected to the motor drive on the communication contact by a communication cable such as RJ-45. 2. Press RESET on the keypad to clear errors. If none of the above solution works, contact your local authorized dealer.
	Modbus data address error	Motor drive doesn't accept keypad's communication address. 1. Verify if the keypad is properly connected to the motor drive on the communication contact by a communication cable such as RJ-45. 2. Press RESET on the keypad to clear errors. If none of the above solution works, contact your local authorized dealer.
	Modbus data value error	Motor drive doesn't accept the communication data sent from keypad. 1. Verify if the keypad is properly connected to the motor drive on the communication contact by a communication cable such as RJ-45. 2. Press RESET on the keypad to clear errors. If none of the above solution works, contact your local authorized dealer.
	Modbus slave drive error	Motor drive cannot process the communication command sent from keypad. 1. Verify if the keypad is properly connected to the motor drive on the communication contact by a communication cable such as RJ-45. 2. Press RESET on the keypad to clear errors. 3. Shut down the system, wait for ten minutes, and then power on again the system. If none of the above solution works, contact your local authorized dealer.
	Modbus transmission time-Out	Motor drive doesn't respond to the communication command sent from keypad. 1. Verify if the keypad is properly connected to the motor drive on the communication contact by a communication cable such as RJ-45. 2. Press RESET on the keypad to clear errors. 3. Shut down the system, wait for ten minutes, and then power on again the system. If none of the above solution works, contact your local authorized dealer.
	Object not supported by TP Editor	Keypad's TP Editor uses unsupported object or Drive series. 1. Verify how the TP Editor should use that object. Delete unsupported object and unsupported setting. 2. Reedit the TP editor and then download it. 3. Make sure the Drive series support TP functions. If it didn't, the main page will display default. If none of the above solution works, contact your local authorized dealer.

 **NOTE** The warning code which shows as “CExx” only occurs when the communication problem between the drive and keypad, and it's nothing to do with the drive and other device. Be noted that the warning code description to judge the cause of error if “CExx” occurs.



### File Copy Setting Fault Description:

These faults will happen when KPC-CC01 cannot perform the command after clicking the Enter button in copy function.

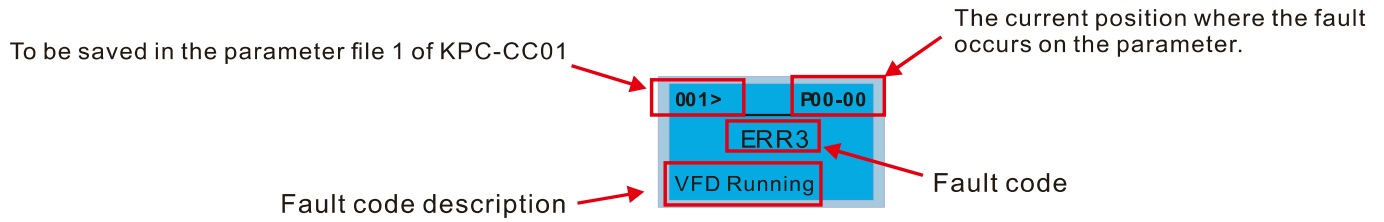

LCM Display *	Description	Corrective Actions
<div style="border: 1px solid black; padding: 5px;"> <div style="display: flex; justify-content: space-between; border-bottom: 1px solid black;"> <span>001&gt;</span> <span>P00-00</span> </div> <p style="text-align: center; margin: 5px 0;"><b>ERR1</b></p> <p style="margin: 5px 0;">Read Only</p> </div>	Parameter and file are read only	The property of the parameter / file is read-only and cannot be written to. 1. Verify the specification on the user manual. If the solution above doesn't work, contact your local authorized dealer.
<div style="border: 1px solid black; padding: 5px;"> <div style="display: flex; justify-content: space-between; border-bottom: 1px solid black;"> <span>001&gt;</span> <span>P00-00</span> </div> <p style="text-align: center; margin: 5px 0;"><b>ERR2</b></p> <p style="margin: 5px 0;">Write Fail</p> </div>	Fail to write parameter and file	An error occurred while writing to a parameter / file. 1. Verify if there's any problem on the Flash IC. 2. Shut down the system, wait for ten minutes, and then power on again the system. If none of the solution above work, contact your local authorized dealer.
<div style="border: 1px solid black; padding: 5px;"> <div style="display: flex; justify-content: space-between; border-bottom: 1px solid black;"> <span>001&gt;</span> <span>P00-00</span> </div> <p style="text-align: center; margin: 5px 0;"><b>ERR3</b></p> <p style="margin: 5px 0;">VFD Running</p> </div>	AC drive is in operating status	A setting cannot be made while motor drive is in operation. 1. Verify if the drive is not in operation. If the solution above doesn't work, contact your local authorized dealer.
<div style="border: 1px solid black; padding: 5px;"> <div style="display: flex; justify-content: space-between; border-bottom: 1px solid black;"> <span>001&gt;</span> <span>P00-00</span> </div> <p style="text-align: center; margin: 5px 0;"><b>ERR4</b></p> <p style="margin: 5px 0;">Pr Lock</p> </div>	AC drive parameter is locked	A setting cannot be made because a parameter is locked. 1. Verify if the parameter is locked or not. If it is locked, unlock it and try to set up the parameter again. If the solution above doesn't work, contact your local authorized dealer.
<div style="border: 1px solid black; padding: 5px;"> <div style="display: flex; justify-content: space-between; border-bottom: 1px solid black;"> <span>001&gt;</span> <span>P00-00</span> </div> <p style="text-align: center; margin: 5px 0;"><b>ERR5</b></p> <p style="margin: 5px 0;">Pr Changing</p> </div>	AC drive parameter changing	A setting cannot be made because a parameter is being modified. 1. Verify if the parameter is being modified. If it is not being modified, try to set up that parameter again. If the solution above doesn't work, contact your local authorized dealer.
<div style="border: 1px solid black; padding: 5px;"> <div style="display: flex; justify-content: space-between; border-bottom: 1px solid black;"> <span>001&gt;</span> <span>P00-00</span> </div> <p style="text-align: center; margin: 5px 0;"><b>ERR6</b></p> <p style="margin: 5px 0;">Fault Code</p> </div>	Fault code	A setting cannot be made because an error has occurred on the motor drive. 1. Verify if there's any error occurred on the motor drive. If there isn't any error, try to make the setting again. If the solution above doesn't work, contact your local authorized dealer.
<div style="border: 1px solid black; padding: 5px;"> <div style="display: flex; justify-content: space-between; border-bottom: 1px solid black;"> <span>001&gt;</span> <span>P00-00</span> </div> <p style="text-align: center; margin: 5px 0;"><b>ERR7</b></p> <p style="margin: 5px 0;">Warning Code</p> </div>	Warning code	A setting cannot be made because of a warning message given to the motor drive. 1. Verify if there's any warning message given to the motor drive. If the solution above doesn't work, contact your local authorized dealer.
<div style="border: 1px solid black; padding: 5px;"> <div style="display: flex; justify-content: space-between; border-bottom: 1px solid black;"> <span>001&gt;</span> <span>P00-00</span> </div> <p style="text-align: center; margin: 5px 0;"><b>ERR8</b></p> <p style="margin: 5px 0;">Type Dismatch</p> </div>	File type dismatch	The copied data are not the same type, so the setting cannot be made. 1. Verify if the products' serial numbers need to be copied fall in the category. If they are in the same category, try to make the setting again. If the solution above doesn't work, contact your authorized dealer.

LCM Display *	Description	Corrective Actions
<div style="border: 1px solid black; padding: 2px;"> <div style="display: flex; justify-content: space-between; font-size: small;"> <span>001&gt;</span> <span>P00-00</span> </div> <div style="text-align: center; font-weight: bold; font-size: large; margin: 5px 0;">ERR9</div> <div style="text-align: center; font-weight: bold; font-size: small;">Password Lock</div> </div>	File is locked with password	<p>A setting cannot be made, because some data are locked.</p> <ol style="list-style-type: none"> <li>1. Verify if the data are unlocked or able to be unlocked. If the data are unlocked, try to make the setting again.</li> <li>2. Shut down the system, wait for ten minutes, and then power on again the system.</li> </ol> <p>If none of the solution above works, contact your local authorized dealer.</p>
<div style="border: 1px solid black; padding: 2px;"> <div style="display: flex; justify-content: space-between; font-size: small;"> <span>001&gt;</span> <span>P00-00</span> </div> <div style="text-align: center; font-weight: bold; font-size: large; margin: 5px 0;">ERR10</div> <div style="text-align: center; font-weight: bold; font-size: small;">Password Fail</div> </div>	File password is incorrect	<p>A setting cannot be made because the password is incorrect.</p> <ol style="list-style-type: none"> <li>1. Verify if the password is correct. If the password is correct, try to make the setting again.</li> <li>2. Shut down the system, wait for ten minutes, and then power on again the system.</li> </ol> <p>If none of the solution above works, contact your local authorized dealer.</p>
<div style="border: 1px solid black; padding: 2px;"> <div style="display: flex; justify-content: space-between; font-size: small;"> <span>001&gt;</span> <span>P00-00</span> </div> <div style="text-align: center; font-weight: bold; font-size: large; margin: 5px 0;">ERR11</div> <div style="text-align: center; font-weight: bold; font-size: small;">Version Fail</div> </div>	Different version of copied data	<p>A setting cannot be made, because the version of the data is incorrect.</p> <ol style="list-style-type: none"> <li>1. Verify if the version of the data matches the motor drive. If it matches, try to make the setting again.</li> </ol> <p>If none of the solution above works, contact your local authorized dealer.</p>
<div style="border: 1px solid black; padding: 2px;"> <div style="display: flex; justify-content: space-between; font-size: small;"> <span>001&gt;</span> <span>P00-00</span> </div> <div style="text-align: center; font-weight: bold; font-size: large; margin: 5px 0;">ERR12</div> <div style="text-align: center; font-weight: bold; font-size: small;">VFD Time Out</div> </div>	AC drive copy function time-out	<p>A setting cannot be made, because data copying timeout expired.</p> <ol style="list-style-type: none"> <li>1. Redo data copying.</li> <li>2. Verify if copying data is authorized. If it is authorized, try again to copy data.</li> <li>3. Shut down the system, wait for ten minutes, and then power on again the system.</li> </ol> <p>If none of the solution above works, contact your local authorized dealer.</p>

※ The content in this chapter only applies on V1.01 and above of KPC-CC01 keypad.

## 10-5 Functions not supported when using TPEditor with KPC-CC01

1. Local Page Setting and Global Setting functions are not supported.



2. [Communication]→[Read from TP] functions are not supported.

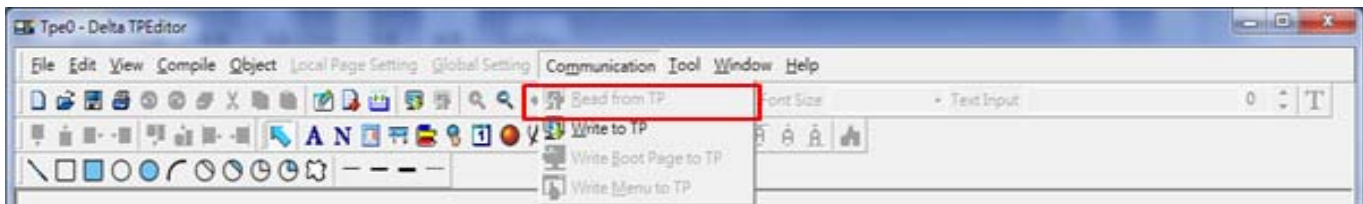

3. In RTC Display Setting, the Refer Device cannot be modified.

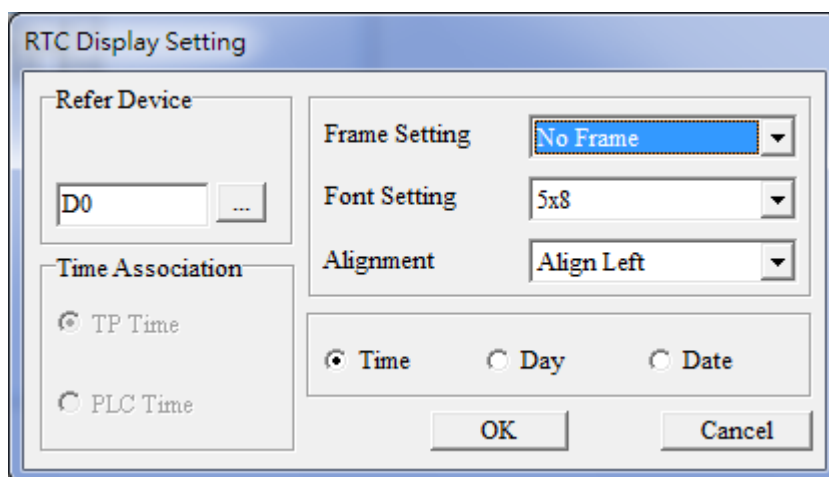

# Chapter 11 Summary of Parameter Settings

This chapter provides a summary of parameter (Pr.) setting ranges and defaults. You can set, change, and reset parameters through the digital keypad.

## NOTE

- 1) : You can set this parameter during operation
- 2) For more details on parameters, please refer to Ch12 Description of Parameter Settings.

## 00 Drive Parameters

 NOTE IM: Induction Motor; PM: Permanent Magnet Motor

Pr.	Parameter Name	Setting Range	Default
00-00	Identity code of the AC motor drive	4: 230V, 0.75kW 5: 460V, 0.75kW 6: 230V, 1.50kW 7: 460V, 1.50kW 8: 230V, 2.20kW 9: 460V, 2.20kW 10: 230V, 3.70kW 11: 460V, 3.70kW 12: 230V, 5.50kW 13: 460V, 5.50kW 14: 230V, 7.50kW 15: 460V, 7.50kW 16: 230V, 11.0kW 17: 460V, 11.0kW 18: 230V, 15.0kW 19: 460V, 15.0kW 20: 230V, 18.5kW 21: 460V, 18.5kW 22: 230V, 22.0kW 23: 460V, 22.0kW 24: 230V, 30.0kW 25: 460V, 30.0kW 26: 230V, 37.0kW 27: 460V, 37.0kW 28: 230V, 45.0kW 29: 460V, 45.0kW 30: 230V, 55.0kW 31: 460V, 55.0kW 32: 230V, 75.0kW 33: 460V, 75.0kW	Read only

Pr.	Parameter Name	Setting Range	Default
		34: 230V, 90.0kW 35: 460V, 90.0kW 37: 460V, 110.0kW 39: 460V, 132.0kW 41: 460V, 160.0kW 43: 460V, 185.0kW 45: 460V, 220.0kW 47: 460V, 280.0kW 49: 460V, 315.0kW 51: 460V, 355.0kW 55: 460V, 450.0kW 93: 460V, 4kW 505: 575V, 1.5kW 506: 575V, 2.2kW 507: 575V, 3.7kW 508: 575V, 5.5kW 509: 575V, 7.5kW 510: 575V, 11kW 511: 575V, 15kW 612: 690V, 18.5kW 613: 690V, 22kW 614: 690V, 30kW 615: 690V, 37kW 616: 690V, 45kW 617: 690V, 55kW 618: 690V, 75kW 619: 690V, 90kW 620: 690V, 110kW 621: 690V, 132kW 622: 690V, 160kW 686: 690V, 200kW 687: 690V, 250kW 626: 690V, 315kW 628: 690V, 400kW 629: 690V, 450kW 631: 690V, 560kW 632: 690V, 630kW	
00-01	Display AC motor drive rated current	Display by models	Read only
00-02	Parameter reset	0: No function 1: Parameter write protect 5: Reset kWh display to 0	0

Pr.	Parameter Name	Setting Range	Default
		6: Reset PLC (including CANopen Master Index) 7: Reset CANopen Index (Slave) 9: Reset all parameters to defaults with base frequency at 50 Hz 10: Reset all parameters to defaults with base frequency at 60 Hz	
↗ 00-03	Start-up display selection	0: F (frequency command) 1: H (output frequency) 2: U (multi-function display, see Pr. 00-04) 3: A (output current)	0
↗ 00-04	Content of multi-function display (user-defined)	0: Display output current (A) (Unit: Amp) 1: Display counter value (c) (Unit: CNT) 2: Display actual output frequency (H.) (Unit: Hz) 3: Display DC BUS voltage (v) (Unit: V <sub>DC</sub> ) 4: Display output voltage (E) (Unit: V <sub>AC</sub> ) 5: Display output power angle (n) (Unit: deg) 6: Display output power in kW (P) (Unit: kW) 7: Display actual motor speed rpm (r) (Unit: rpm) 8: Display estimate output torque % (t) (Unit: %) 9: Display PG feedback (G) (refer to Pr. 10-00 and Pr. 10-01) (Unit: PLS) 10: Display PID feedback (b) (Unit: %) 11: Display AVI in % (1.) (Unit: %) 12: Display ACI in % (2.) (Unit: %) 13: Display AUI in % (3.) (Unit: %) 14: Display the temperature of IGBT (i.) (Unit: °C) 15: Display the temperature of capacitance (c.) (Unit: °C) 16: The status of digital input (ON / OFF) (i) 17: The status of digital output (ON / OFF) (o) 18: Multi-step speed (S) 19: The corresponding CPU pin status of digital input (d) 20: The corresponding CPU pin status of digital output (0.) 21: Actual motor position (PG1 of PG card) (P.) The maximum value is 32bits display 22: Pulse input frequency (PG2 of PG card) (S.) 23: Pulse input position (PG2 of PG card) (q.) The maximum value is 32bits display	3

Pr.	Parameter Name	Setting Range	Default	
		24: Position command tracing error (E.) 25: Overload count (0.00~100.00%) (o.) (Unit: %) 26: Ground fault GFF (G.) (Unit: %) 27: DC BUS voltage ripple (r.) (Unit: V <sub>DC</sub> ) 28: Display PLC data D1043 (C) 29: Display PM pole section (EMC-PG01U application) (4.) 30: Display output of user defined (U) 31: Display Pr. 00-05 user gain (K) 32: Number of actual motor revolution during operation (PG card plug in and Z phase signal input) (Z.) 33: Motor actual position during operation (when PG card is connected) (q) 34: Operation speed of fan (F.) (Unit: %) 35: Control mode display: 0 = Speed control mode (SPD) 1 = Torque control mode (TQR) (t.) 36: Present operating carrier frequency of drive (Hz) (J.) 38: Display drive status (6.) 39: Display estimated output torque, positive and negative, using Nt-m as unit (t 0.0: positive torque; -0.0: negative torque (C.) 40: Torque command (L.) (Unit: %) 41: kWh display (J) (Unit: kWh) 42: PID target value (h.) (Unit: %) 43: PID offset (o.) (Unit: %) 44: PID output frequency (b.) (Unit: Hz) 45: Hardware ID 49: Motor temperature (PTC, PT100, KTY84-130) 51: PMSVC torque offset 52: AI10% 53: AI11%		
↗	00-05	Coefficient gain in actual output frequency	0.00–160.00	1.00
	00-06	Software version	Read only	Read only
↗	00-07	Parameter protection password input	0–65535 0–4: the number of password attempts allowed	0

Pr.	Parameter Name	Setting Range	Default																				
00-08	Parameter protection password setting	0–65535 0: No password protection / password entered correctly (Pr. 00-07) 1: Parameter set	0																				
00-10	Control mode	0: Speed mode 1: Point-to-point position control mode 2: Torque mode 3: Homing mode	0																				
00-11	Speed control mode	0: IMVF (IM V/F control) 1: IMVFPG (IM V/F control + Encoder) 2: IM/PM SVC (IM / PM space vector control) 3: IMFOCPG (IM FOC + Encoder) 4: PMFOCPG (PM FOC + Encoder) 5: IMFOC sensorless (IM FOC sensorless ) 6: PM sensorless (PM FOC sensorless) 7: IPM sensorless (Interior PM FOC sensorless)	0																				
00-12	Point-to-point position mode	0: Relative position 1: Absolute position	0																				
00-13	Torque mode control	0: IM TQCPG (IM torque control + Encoder) 1: PM TQCPG (PM torque control + Encoder) 2: IM TQC sensorless (IM sensorless torque control)	0																				
00-16	Load selection	0: Normal load 1: Heavy load	0																				
00-17	Carrier frequency	<b>Normal load</b> <table border="1"> <thead> <tr> <th>230V/460V</th> <th>VF, VFPG, SVC, IMFOCPG, IMTQCPG</th> <th>PMFOCPG, PMTQCPG</th> <th>PMFOC, IPMFOC</th> <th>IMFOC, IMTQC</th> </tr> </thead> <tbody> <tr> <td>1–15HP</td> <td>2–15kHz</td> <td>4–15kHz</td> <td>4–10kHz</td> <td>4–14kHz</td> </tr> <tr> <td>20–50HP</td> <td>2–10kHz</td> <td>4–10kHz</td> <td>4–10kHz</td> <td>4–10kHz</td> </tr> <tr> <td>60–125HP</td> <td>2–9kHz</td> <td>4–9kHz</td> <td>4–9kHz</td> <td>4–9kHz</td> </tr> </tbody> </table>	230V/460V	VF, VFPG, SVC, IMFOCPG, IMTQCPG	PMFOCPG, PMTQCPG	PMFOC, IPMFOC	IMFOC, IMTQC	1–15HP	2–15kHz	4–15kHz	4–10kHz	4–14kHz	20–50HP	2–10kHz	4–10kHz	4–10kHz	4–10kHz	60–125HP	2–9kHz	4–9kHz	4–9kHz	4–9kHz	8 6 4
		230V/460V	VF, VFPG, SVC, IMFOCPG, IMTQCPG	PMFOCPG, PMTQCPG	PMFOC, IPMFOC	IMFOC, IMTQC																	
		1–15HP	2–15kHz	4–15kHz	4–10kHz	4–14kHz																	
20–50HP	2–10kHz	4–10kHz	4–10kHz	4–10kHz																			
60–125HP	2–9kHz	4–9kHz	4–9kHz	4–9kHz																			
<b>Heavy load</b> <table border="1"> <thead> <tr> <th>230V/460V</th> <th>VF, VFPG, SVC, IMFOCPG, IMTQCPG</th> <th>PMFOCPG, PMTQCPG</th> <th>PMFOC, IPMFOC</th> <th>IMFOC, IMTQC</th> </tr> </thead> <tbody> <tr> <td>1–15HP</td> <td>2–15kHz</td> <td>4–15kHz</td> <td>4–10kHz</td> <td>4–14kHz</td> </tr> <tr> <td>20–50HP</td> <td>2–10kHz</td> <td>4–10kHz</td> <td>4–10kHz</td> <td>4–10kHz</td> </tr> <tr> <td>60–125HP</td> <td>2–9kHz</td> <td>4–9kHz</td> <td>4–9kHz</td> <td>4–9kHz</td> </tr> </tbody> </table>	230V/460V	VF, VFPG, SVC, IMFOCPG, IMTQCPG	PMFOCPG, PMTQCPG	PMFOC, IPMFOC	IMFOC, IMTQC	1–15HP	2–15kHz	4–15kHz	4–10kHz	4–14kHz	20–50HP	2–10kHz	4–10kHz	4–10kHz	4–10kHz	60–125HP	2–9kHz	4–9kHz	4–9kHz	4–9kHz	2		
230V/460V	VF, VFPG, SVC, IMFOCPG, IMTQCPG	PMFOCPG, PMTQCPG	PMFOC, IPMFOC	IMFOC, IMTQC																			
1–15HP	2–15kHz	4–15kHz	4–10kHz	4–14kHz																			
20–50HP	2–10kHz	4–10kHz	4–10kHz	4–10kHz																			
60–125HP	2–9kHz	4–9kHz	4–9kHz	4–9kHz																			
<b>575V/690V (Light/ Normal/ Heavy load)</b> <table border="1"> <thead> <tr> <th>Power/ Control mode</th> <th>VF, VFPG, SVC</th> </tr> </thead> <tbody> <tr> <td>1–15HP (575V)</td> <td>2–15kHz</td> </tr> <tr> <td>20–600HP (690V)</td> <td>2–9kHz</td> </tr> <tr> <td>850HP (690V)</td> <td>2–9kHz</td> </tr> </tbody> </table>	Power/ Control mode	VF, VFPG, SVC	1–15HP (575V)	2–15kHz	20–600HP (690V)	2–9kHz	850HP (690V)	2–9kHz	6 4 3														
Power/ Control mode	VF, VFPG, SVC																						
1–15HP (575V)	2–15kHz																						
20–600HP (690V)	2–9kHz																						
850HP (690V)	2–9kHz																						



Pr.	Parameter Name	Setting Range	Default
00-19	PLC command mask	bit0: Control command by PLC force control bit1: Frequency command by PLC force control bit2: Position command by PLC force control bit3: Torque command by PLC force control	Read only
00-20	Master frequency command (AUTO) source / Source selection of the PID target	0: Digital keypad 1: RS-485 communication 2: External analog input (Pr. 03-00) 3: External UP / DOWN terminal (multi-function input terminal) 4: Pulse input without direction command (Pr.10-16 without direction), use with PG card 5: Pulse input with direction command (Pr. 10-16), use with PG card 6: CANopen communication card 8: Communication card (does not include CANopen card)	0
00-21	Operation command (AUTO) source	0: Digital keypad 1: External terminals. 2: RS-485 communication. 3: CANopen communication card 5: Communication card (does not include CANopen card)	0
↗ 00-22	Stop method	0: Ramp to stop 1: Coast to stop	0
↗ 00-23	Control of motor direction	0: Enable forward / reverse 1: Disable reverse 2: Disable forward	0
00-24	Digital keypad frequency command memory	Read only	Read only
↗ 00-25	User defined characteristics	bit0–3: user defined decimal place 0000b: no decimal place 0001b: one decimal place 0010b: two decimal places 0011b: three decimal places bit4–15: user defined unit 000xh: Hz 001xh: rpm 002xh: % 003xh: kg 004xh: m/s	0

Pr.	Parameter Name	Setting Range	Default
		005xh: kW 006xh: HP 007xh: ppm 008xh: 1/m 009xh: kg/s 00Axh: kg/m 00Bxh: kg/h 00Cxh: lb/s 00Dxh: lb/m 00Exh: lb/h 00Fxh: ft/s 010xh: ft/m 011xh: m 012xh: ft 013xh: degC 014xh: degF 015xh: mbar 016xh: bar 017xh: Pa 018xh: kPa 019xh: mWG 01Axh: inWG 01Bxh: ftWG 01Cxh: psi 01Dxh: atm 01Exh: L/s 01Fh: L/m 020xh: L/h 021xh: m3/s 022xh: m3/h 023xh: GPM 024xh: CFM xxxh: Hz	
00-26	Maximum user-defined value	0: Disable 0–65535 (when Pr. 00-25 set to no decimal place) 0.0–6553.5 (when Pr. 00-25 set to 1 decimal place) 0.00–655.35 (when Pr. 00-25 set to 2 decimal places) 0.000–65.535 (when Pr. 00-25 set to 3 decimal places)	0

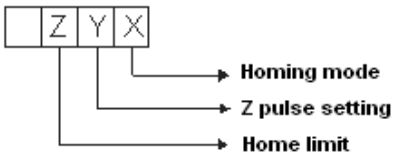
Pr.	Parameter Name	Setting Range	Default
00-27	User-defined value	Read only	Read Only
00-29	LOCAL / REMOTE mode	0: Standard HOA function 1: When switching between local and remote, the drive stops. 2: When switching between local and remote, the drive runs with REMOTE settings for frequency and operation status. 3: When switching between local and remote, the drive runs with LOCAL settings for frequency and operation status. 4: When switching between local and remote, the drive runs with LOCAL settings when switched to Local and runs with REMOTE settings when switched to Remote for frequency and operation status.	0
00-30	Master frequency command (HAND) source	0: Digital keypad 1: RS-485 communication 2: External analog input (Pr. 03-00) 3: External UP / DOWN terminal 4: Pulse input without direction command (Pr. 10-16 without direction) 5: Pulse input with direction command (Pr. 10-16) 6: CANopen communication card 8: Communication card (does not include CANopen card)	0
00-31	Operation command (HAND) source	0: Digital keypad 1: External terminals. 2: RS-485 communication. 3: CANopen communication card 5: Communication card (does not include CANopen card)	0
00-32	Digital keypad STOP function	0: Disable STOP key 1: Enable STOP key	0
00-40	Homing mode		0000h
		Note: Forward run = clockwise (CW) Reverse run = counterclockwise (CCW)	

Pr.	Parameter Name	Setting Range	Default
		<p>0: Forward run to home. Set PL forward limit as check point.</p> <p>1: Reverse run (CCW) to home. Set NL reverse limit (CCWL) as check point.</p> <p>2: Forward run to home. Set ORG: OFF → ON as check point.</p> <p>3: Reverse to home. Set ORG: OFF → ON as check point.</p> <p>4: Forward run and search for Z-pulse as check point.</p> <p>5: Reverse run and search for Z-pulse as check point.</p> <p>6: Forward run to home. Set ORG: ON → OFF as check point.</p> <p>7: Reverse run to home. Set ORG: ON → OFF as check point.</p> <p>8: Define current position as home.</p>	
		<p>Y</p> <p>Set X to 0, 1, 2, 3, 6, 7 first.</p> <p>0: Reverse run to Z pulse</p> <p>1: Continue forward run to Z pulse</p> <p>2: Ignore Z pulse</p>	
		<p>Z</p> <p>When home limit is reached, set X to 2, 3, 4, 5, 6, 7 first.</p> <p>0: Display the error</p> <p>1: Reverse the direction</p>	
↗	00-41 Homing by frequency 1	0.00–599.00 Hz	8.00
↗	00-42 Homing by frequency 2	0.00–599.00 Hz	2.00
↗	00-48 Display filter time (current)	0.001–65.535 sec.	0.100
↗	00-49 Display filter time (keypad)	0.001–65.535 sec.	0.100
	00-50 Software version (date)	Read only	#####

## 01 Basic Parameters

Pr.	Parameter Name	Setting Range	Default
✓ 01-00	Maximum operation frequency	0.00–599.00 Hz	60.00 / 50.00
01-01	Output frequency of motor 1	0.00–599.00 Hz	60.00 / 50.00
01-02	Output voltage of motor 1	230V: 0.0–255.0 V 460V: 0.0–510.0 V 575V: 0.0–637.0 V 690V: 0.0–765.0 V	200.0 400.0 575.0 660.0
01-03	Mid-point frequency 1 of motor 1	0.00–599.00 Hz	3.00
✓ 01-04	Mid-point voltage 1 of motor 1	230V: 0.0–240.0 V 460V: 0.0–480.0 V 575V: 0.0–637.0 V 690V: 0.0–720.0 V	11.0 22.0 0.0 0.0
01-05	Mid-point frequency 2 of motor 1	0.00–599.00 Hz	1.50
✓ 01-06	Mid-point voltage 2 of motor 1	230V: 0.0–240.0 V 460V: 0.0–480.0 V 575V: 0.0V–637.0 V 690V: 0.0–720.0 V	5.0 10.0 0.0 0.0
01-07	Min. output frequency of motor 1	0.00–599.00 Hz	0.50
✓ 01-08	Min. output voltage of motor 1	230V: 0.0–240.0 V 460V: 0.0–480.0 V 575V: 0.0–637.0 V 690V: 0.0–720.0 V	1.0 2.0 0.0 0.0
01-09	Start-up frequency	0.00–599.00 Hz	0.50
✓ 01-10	Output frequency upper limit	0.00–599.00 Hz	599.00
✓ 01-11	Output frequency lower limit	0.00–599.00 Hz	0
✓ 01-12	Acceleration time 1	Pr. 01-45=0: 0.00–600.00 sec. Pr. 01-45=1: 0.00–6000.0 sec. The default of motor drive with 30HP and above: 60.00 / 60.0	10.00
✓ 01-13	Deceleration time 1	Pr. 01-45=0: 0.00–600.00 sec. Pr. 01-45=1: 0.00–6000.0 sec. The default of motor drive with 30HP and above: 60.00 / 60.0	10.00
✓ 01-14	Acceleration time 2	Pr. 01-45=0: 0.00–600.00 sec. Pr. 01-45=1: 0.00–6000.0 sec. The default of motor drive with 30HP and above: 60.00 / 60.0	10.00
✓ 01-15	Deceleration time 2	Pr. 01-45=0: 0.00–600.00 sec.	10.00

Pr.	Parameter Name	Setting Range	Default
		Pr. 01-45=1: 0.00–6000.0 sec. The default of motor drive with 30HP and above: 60.00 / 60.0	
✎ 01-16	Acceleration time 3	Pr. 01-45=0: 0.00–600.00 sec. Pr. 01-45=1: 0.00–6000.0 sec. The default of motor drive with 30HP and above: 60.00 / 60.0	10.00
✎ 01-17	Deceleration time 3	Pr. 01-45=0: 0.00–600.00 sec. Pr. 01-45=1: 0.00–6000.0 sec. The default of motor drive with 30HP and above: 60.00 / 60.0	10.00
✎ 01-18	Acceleration time 4	Pr. 01-45=0: 0.00–600.00 sec. Pr. 01-45=1: 0.00–6000.0 sec. The default of motor drive with 30HP and above: 60.00 / 60.0	10.00
✎ 01-19	Deceleration time 4	Pr. 01-45=0: 0.00–600.00 sec. Pr. 01-45=1: 0.00–6000.0 sec. The default of motor drive with 30HP and above: 60.00 / 60.0	10.00
✎ 01-20	JOG acceleration time	Pr. 01-45=0: 0.00–600.00 sec. Pr. 01-45=1: 0.00–6000.0 sec. The default of motor drive with 30HP and above: 60.00 / 60.0	10.00
✎ 01-21	JOG deceleration time	Pr. 01-45=0: 0.00–600.00 sec. Pr. 01-45=1: 0.00–6000.0 sec. The default of motor drive with 30HP and above: 60.00 / 60.0	10.00
✎ 01-22	JOG frequency	0.00–599.00Hz	6.00
✎ 01-23	First / Fourth acceleration / deceleration frequency	0.00–599.00Hz	0.00
✎ 01-24	S-curve acceleration begin time 1	Pr. 01-45=0: 0.00–25.00 sec. Pr. 01-45=1: 0.0–250.0 sec.	0.20
✎ 01-25	S-curve acceleration arrival time 2	Pr. 01-45=0: 0.00–25.00 sec. Pr. 01-45=1: 0.0–250.0 sec.	0.20
✎ 01-26	S-curve deceleration begin time 1	Pr. 01-45=0: 0.00–25.00 sec. Pr. 01-45=1: 0.0–250.0 sec.	0.20
✎ 01-27	S-curve deceleration arrival time 2	Pr. 01-45=0: 0.00–25.00 sec. Pr. 01-45=1: 0.0–250.0 sec.	0.20
01-28	Skip frequency 1 (upper limit)	0.00–599.00 Hz	0.00
01-29	Skip frequency 1 (lower limit)	0.00–599.00 Hz	0.00
01-30	Skip frequency 2 (upper limit)	0.00–599.00 Hz	0.00

Pr.	Parameter Name	Setting Range	Default
01-31	Skip frequency 2 (lower limit)	0.00–599.00 Hz	0.00
01-32	Skip frequency 3 (upper limit)	0.00–599.00 Hz	0.00
01-33	Skip frequency 3 (lower limit)	0.00–599.00 Hz	0.00
01-34	Zero-speed mode	0: Waiting for output 1: Zero-speed operation 2: Minimum frequency (Refer to Pr. 01-07, 01-41)	0
01-35	Output frequency of motor 2	0.00–599.00 Hz	60.00 / 50.00
01-36	Output voltage of motor 2	230V: 0.0–255.0 V 460V: 0.0–510.0 V 575V: 0.0–637.0 V 690V: 0.0–765.0 V	200.0 400.0 575.0 660.0
01-37	Mid-point frequency 1 of motor 2	0.00–599.00 Hz	3.00
↗ 01-38	Mid-point voltage 1 of motor 2	230V: 0.0–240.0 V 460V: 0.0–480.0 V 575V: 0.0–637.0 V 690V: 0.0–720.0 V	11.0 22.0 0.0 0.0
01-39	Mid-point frequency 2 of motor 2	0.00–599.00 Hz	1.50
↗ 01-40	Mid-point voltage 2 of motor 2	230V: 0.0–240.0 V 460V: 0.0–480.0 V 575V: 0.0–637.0 V 690V: 0.0–720.0 V	5.0 10.0 0.0 0.0
01-41	Min. output frequency of motor 2	0.00–599.00 Hz	0.50
↗ 01-42	Min. output voltage of motor 2	230V: 0.0–240.0 V 460V: 0.0–480.0 V 575V: 0.0–637.0 V 690V: 0.0–720.0 V	1.0 2.0 0.0 0.0
01-43	V/F curve selection	0: V/F curve determined by Pr. 01-00–01-08 1: 1.5 <sup>th</sup> V/F curve 2: 2 <sup>nd</sup> V/F curve 3: 60Hz, voltage saturation in 50Hz 4: 72Hz, voltage saturation in 60Hz 5: 50Hz, decrease gradually with cube 6: 50Hz, decrease gradually with square 7: 60Hz, decrease gradually with cube 8: 60Hz, decrease gradually with square 9: 50Hz, medium starting torque 10: 50Hz, high starting torque 11: 60Hz, medium starting torque 12: 60Hz, high starting torque	0

Pr.	Parameter Name	Setting Range	Default
		13: 90Hz, voltage saturation in 60Hz 14: 120Hz, voltage saturation in 60Hz 15: 180Hz, voltage saturation in 60Hz	
✎ 01-44	Auto-acceleration and auto-deceleration setting	0: Linear acceleration and linear deceleration 1: Auto-acceleration and linear deceleration 2: Linear acceleration and auto-deceleration 3: Auto-acceleration and auto-deceleration 4: Stall prevention by auto-acceleration and auto-deceleration (limited by Pr. 01-12~01-21)	0
01-45	Time unit for accel. / decel. and S curve	0: Unit: 0.01 sec. 1: Unit: 0.1 sec.	0
✎ 01-46	CANopen quick stop time	Pr. 01-45=0: 0.00–600.00 sec. Pr. 01-45=1: 0.0–6000.0 sec.	1.00
01-49	Regenerative energy restriction control method	0: Disable 1: Over voltage energy restriction 2: Traction energy control (TEC)	0



## 02 Digital Input / Output Parameters

Pr.	Parameter Name	Setting Range	Default
02-00	Two-wire / Three-wire operation control	0: Two-wire mode 1, power on for operation control 1: Two -wire mode 2, power on for operation control 2: Three-wire, power on for operation control	0
02-01	Multi-function input command 1 (MI1)	0: No function	1
02-02	Multi-function input command 2 (MI2)	1: Multi-step speed command 1 / multi-step position command 1	2
02-03	Multi-function input command 3 (MI3)		3
02-04	Multi-function input command 4 (MI4)	2: Multi-step speed command 2 / multi-step position command 2	4
02-05	Multi-function input command 5 (MI5)		0
02-06	Multi-function input command 6 (MI6)	3: Multi-step speed command 3 / multi-step position command 3	0
02-07	Multi-function input command 7 (MI7)		0
02-08	Multi-function input command 8 (MI8)	4: Multi-step speed command 4 / multi-step position command 4	0
02-26	Input terminal of I/O extension card (MI10)	5: Reset	0
02-27	Input terminal of I/O extension card (MI11)	6: JOG command (By KPC-CC01 or external control)	0
02-28	Input terminal of I/O extension card (MI12)	7: Acceleration / deceleration speed inhibit 8: 1 <sup>st</sup> and 2 <sup>nd</sup> acceleration / deceleration time selection	0
02-29	Input terminal of I/O extension card (MI13)	9: 3 <sup>rd</sup> and 4 <sup>th</sup> acceleration / deceleration time selection	0
02-30	Input terminal of I/O extension card (MI14)	10: EF input (Pr. 07-20)	0
02-31	Input terminal of I/O extension card (MI15)	11: Base Block (B.B) input from external 12: Output stop	0
		13: Cancel the setting of auto-acceleration / auto-deceleration time 14: Switch between motor 1 and motor 2 15: Rotating speed command from AVI 16: Rotating speed command from ACI 17: Rotating speed command from AUI 18: Forced to stop (Pr. 07-20) 19: Digital up command 20: Digital down command 21: PID function disabled 22: Clear the counter 23: Input the counter value (MI6) 24: FWD JOG command 25: REV JOG command	

Pr.	Parameter Name	Setting Range	Default
		26: TQC / FOC mode selection 27: ASR1 / ASR2 selection 28: Emergency stop (EF1) 29: Signal confirmation for Y-connection 30: Signal confirmation for Δ-connection 31: High torque bias (Pr. 11-30) 32: Middle torque bias (Pr. 11-31) 33: Low torque bias (Pr. 11-32) 34: Switch between multi-step position and multi-step speed control 35: Enable single-point position control 36: Enable multi-step position learning function (valid at stop) 37: Enable full position control pulse command input 38: Disable write EEPROM function 39: Torque command direction 40: Force coasting to stop 41: HAND switch 42: AUTO switch 43: Enable resolution selection (Pr. 02-48) 44: Reverse direction homing (NL) 45: Forward direction homing (PL) 46: Homing (ORG) 47: Enable homing function 48: Mechanical gear ratio switch 49: Enable drive 50: Slave dEb action to execute 51: Selection for PLC mode bit 0 52: Selection for PLC mode bit 1 53: Trigger CANopen quick stop 55: Brake release 56: Local / Remote selection	
✓ 02-09	UP / DOWN key mode	0: UP / DOWN by acceleration / deceleration time 1: UP / DOWN constant speed (Pr. 02-10)	0
✓ 02-10	Constant speed, acceleration / deceleration speed of the UP / DOWN key	0.001–1.000Hz / ms	0.001
✓ 02-11	Multi-function input response time	0.000–30.000 sec.	0.005
✓ 02-12	Multi-function input mode selection	0000h–FFFFh (0: N.O.; 1: N.C.)	0000h

Pr.	Parameter Name	Setting Range	Default
02-13	Multi-function output 1 RLY1	0: No function	11
02-14	Multi-function output 2 RLY2	1: Indication during RUN	1
02-16	Multi-function output 3 (MO1)	2: Operation speed reached	66
02-17	Multi-function output 4 (MO2)	3: Desired frequency reached 1 (Pr. 02-22)	0
02-36	Output terminal of the I/O extension card (MO10) or (RA10)	4: Desired frequency reached 2 (Pr. 02-24) 5: Zero speed (Frequency command)	0
02-37	Output terminal of I/O extension card (MO11) or (RA11)	6: Zero speed including STOP (Frequency command)	0
02-38	Output terminal of I/O extension card (RA12)	7: Over-torque 1 (Pr. 06-06–06-08) 8: Over-torque 2 (Pr. 06-09–06-11)	0
02-39	Output terminal of I/O extension card (RA13)	9: Drive is ready 10: Low voltage warning (Lv) (Pr. 06-00)	0
02-40	Output terminal of I/O extension card (RA14)	11: Malfunction indication 12: Mechanical brake release (Pr. 02-32)	0
02-41	Output terminal of I/O extension card (RA15)	13: Over-heat warning (Pr. 06-15) 14: Software brake signal indication (Pr. 07-00)	0
02-42	Output terminal of I/O extension card (MO16 virtual terminal)	15: PID feedback error (Pr. 08-13, Pr. 08-14) 16: Slip error (oSL)	0
02-43	Output terminal of I/O extension card (MO17 virtual terminal)	17: Count value reached, does not return to 0 (Pr. 02-20)	0
02-44	Output terminal of I/O extension card (MO18 virtual terminal)	18: Count value reached, returns to 0 (Pr. 02-19)	0
02-45	Output terminal of I/O extension card (MO19 virtual terminal)	19: External interrupt B.B. input (Base Block) 20: Warning output	0
02-46	Output terminal of I/O extension card (MO20 virtual terminal)	21: Over-voltage 22: Over-current stall prevention 23: Over-voltage stall prevention 24: Operation mode 25: Forward command 26: Reverse command 27: Output when current $\geq$ Pr. 02-33 28: Output when current $<$ Pr. 02-33 29: Output when frequency $\geq$ Pr. 02-34 30: Output when frequency $<$ Pr. 02-34 31: Y-connection for the motor coil 32: $\Delta$ -connection for the motor coil 33: Zero speed (actual output frequency) 34: Zero speed including stop (actual output frequency) 35: Error output selection 1 (Pr. 06-23)	0

Pr.	Parameter Name	Setting Range	Default	
		36: Error output selection 2 (Pr. 06-24) 37: Error output selection 3 (Pr. 06-25) 38: Error output selection 4 (Pr. 06-26) 39: Position reached (Pr. 10-19) 40: Speed reached (including stop) 41: Multi-position reached 42: Crane function 43: Actual motor speed higher than Pr. 02-47 44: Low current output (use with Pr. 06-71~06-73) 45: UVW output electromagnetic valve switch 46: Master dEb output 47: Closed brake output 49: Homing action complete output 50: Output control for CANopen 51: Analog output control for RS485 interface (InnerCOM / MODBUS) 52: Output control for communication cards 65: Output for both CAN & 485 control 66: SO output logic A 67: Analog input level reached 68: SO output logic B 70: FAN warning output		
✓	02-18	Multi-function output direction	0000h~FFFFh (0: N.O.; 1: N.C.)	0000h
✓	02-19	Terminal counting value reached (returns to 0)	0~65500	0
✓	02-20	Preliminary counting value reached (does not return to 0)	0~65500	0
✓	02-21	Digital output gain (DFM)	1~166	1
✓	02-22	Desired frequency reached 1	0.00~599.00Hz	60.00 / 50.00
✓	02-23	The width of the desired frequency reached 1	0.00~599.00Hz	2.00
✓	02-24	Desired frequency reached 2	0.00~599.00Hz	60.00 / 50.00
✓	02-25	The width of the desired frequency reached 2	0.00~599.00Hz	2.00
	02-32	Brake delay time	0.000~65.000 sec.	0.000
✓	02-33	Output current level setting for multi-function output terminal	0~100%	0

Pr.	Parameter Name	Setting Range	Default
↗ 02-34	Output frequency setting for multi-function output terminal	0.00–599.00Hz (Motor speed when using PG Card)	3.00
↗ 02-35	External operation control selection after reset and activate	0: Disable 1: Drive runs if the RUN command remains after reset or reboot	0
↗ 02-47	Motor zero-speed level	0–65535 rpm	0
↗ 02-48	Maximum frequency of resolution switch	0.00–599.00Hz	60.00
↗ 02-49	Switch delay time of maximum output frequency	0–65.000 sec.	0.000
02-50	Display the status of multi-function input terminal	Monitor the status of multi-function input terminals	Read only
02-51	Display the status of multi-function output terminal	Monitor the status of multi-function output terminals	Read only
02-52	Display the external multi-function input terminals used by PLC	Monitor the status of PLC input terminals	Read only
02-53	Display the external multi-function output terminals used by PLC	Monitor the status of PLC output terminals	Read only
02-54	Display the frequency command executed by external terminal	0.00–599.00Hz (Read only)	Read only
02-56	Brake release check time	0.000–65.000 sec.	0.000
↗ 02-57	Multi-function output terminal: function 42: brake current check point	0–100%	0
↗ 02-58	Multi-function output terminal (function 42): brake frequency check point	0.00–599.00Hz	0.00
02-63	Frequency reached detection amplitude	0.00–599.00Hz	0.00
02-70	IO card types	1: EMC-BPS01 4: EMC-D611A 5: EMC-D42A 6: EMC-R6AA 11: EMC-A22A	Read only
02-71	DFM output selection	0: Use frequency with speed control as DFM output frequency 1: Use frequency with system acceleration / deceleration as DFM output frequency	0
02-74	Internal / external multi-function input terminal selection	0000–FFFFh	0000h

Pr.	Parameter Name	Setting Range	Default
02-75	Internal multi-function output terminal selection	0000–FFFFh	0000h

### 03 Analog Input / Output Parameters

Pr.	Parameter Name	Setting Range	Default
✓ 03-00	Analog input selection (AVI)	0: No function	1
✓ 03-01	Analog input selection (ACI)	1: Frequency command (speed limit under torque control mode) 2: Torque command (torque limit under speed mode) 3: Torque compensation command 4: PID target value 5: PID feedback signal 6: Thermistor (PTC / KTY-84) input value 7: Positive torque limit 8: Negative torque limit 9: Regenerative torque limit 10: Positive / negative torque limit 11: PT100 thermistor input value 13: PID compensation value	0
✓ 03-02	Analog input selection (AUI)		0
✓ 03-03	Analog input bias (AVI)	-100.0–100.0%	0.0
✓ 03-04	Analog input bias (ACI)	-100.0–100.0%	0.0
✓ 03-05	Analog input bias (AUI)	-100.0–100.0%	0.0
✓ 03-07	Positive / negative bias mode (AVI)	0: No bias 1: Lower than or equal to bias 2: Greater than or equal to bias 3: The absolute value of the bias voltage while serving as the center 4: Bias serves as the center	0
✓ 03-08	Positive / negative bias mode (ACI)		
✓ 03-09	Positive / negative bias mode (AUI)		
03-10	Reverse setting when analog signal input is negative frequency	0: Negative frequency is not allowed. The digital keypad or external terminal controls the forward and reverse direction. 1: Negative frequency is allowed. Positive frequency = run in forward direction; negative frequency = run in reverse direction. The digital keypad or external terminal control cannot switch the running direction.	0
✓ 03-11	Analog input gain (AVI)	-500.0–500.0%	100.0
✓ 03-12	Analog input gain (ACI)	-500.0–500.0%	100.0
✓ 03-13	Analog positive input gain (AUI)	-500.0–500.0%	100.0
✓ 03-14	Analog negative input gain (AUI)	-500.0–500.0%	100.0
✓ 03-15	Analog input filter time (AVI)	0.00–20.00 sec.	0.01
✓ 03-16	Analog input filter time (ACI)	0.00–20.00 sec.	0.01
✓ 03-17	Analog input filter time (AUI)	0.00–20.00 sec.	0.01

Pr.	Parameter Name	Setting Range	Default
✓ 03-18	Analog input addition function	0: Disable (AVI, ACI, AUI) 1: Enable	0
03-19	Signal loss selection for analog input 4–20mA	0: Disable 1: Continue operation at the last frequency 2: Decelerate to 0Hz 3: Stop immediately and display ACE	0
✓ 03-20	Multi-function output 1 (AFM1)	0: Output frequency (Hz)	0
✓ 03-23	Multi-function output 2 (AFM2)	1: Frequency command (Hz)	0
		2: Motor speed (Hz) 3: Output current (rms) 4: Output voltage 5: DC BUS voltage 6: Power factor 7: Power 8: Output torque 9: AVI 10: ACI 11: AUI 12: Iq current command 13: Iq feedback value 14: Id current command 15: Id feedback value 18: Torque command 19: PG2 frequency command 20: CANopen analog output 21: RS-485 analog output 22: Communication card analog output 23: Constant voltage output 25: CANopen and RS-485 analog output	
✓ 03-21	Analog output gain 1 (AFM1)	0.0–500.0%	100.0
✓ 03-22	Analog output 1 in REV direction (AFM1)	0: Absolute value of output voltage 1: Reverse output 0 V; forward output 0–10 V 2: Reverse output 5–0 V; forward output 5–10 V	0
✓ 03-24	Analog output gain 2 (AFM2)	0.0–500.0%	100.0
✓ 03-25	Analog output 2 in REV direction (AFM2)	0: Absolute value of output voltage 1: Reverse output 0 V; forward output 0–10 V 2: Reverse output 5–0 V; forward output 5–10 V	0
✓ 03-27	AFM2 output bias	-100.00–100.00%	0.00
✓ 03-28	AVI terminal input selection	0: 0–10V 1: 0–20mA 2: 4–20mA	0



Pr.	Parameter Name	Setting Range	Default
✓ 03-29	ACI terminal input selection	0: 4–20mA 1: 0–10V 2: 0–20mA	0
03-30	PLC analog output terminal status	Monitor the status of PLC analog output terminals	Read only
✓ 03-31	AFM2 output selection	0: 0–20mA output 1: 4–20mA output	0
✓ 03-32	AFM1 DC output setting level	0.00–100.00%	0.00
✓ 03-33	AFM2 DC output setting level	0.00–100.00%	0.00
✓ 03-35	AFM1 filter output time	0.00–20.00 sec.	0.01
✓ 03-36	AFM2 filter output time	0.00–20.00 sec.	0.01
✓ 03-44	Multi-function MO output by AI level source	0: AVI 1: ACI 2: AUI	0
✓ 03-45	AI upper level	-100.00–100.00%	50.00
✓ 03-46	AI lower level	-100.00–100.00%	10.00
✓ 03-50	Analog input curve selection	0: Regular curve 1: Three-point curve of AVI 2: Three-point curve of ACI 3: Three-point curve of AVI & ACI 4: Three-point curve of AUI 5: Three-point curve of AVI & AUI 6: Three-point curve of ACI & AUI 7: Three-point curve of AVI & ACI & AUI	0
✓ 03-51	AVI lowest point	Pr. 03-28=0, 0.00–10.00V Pr. 03-28=1, 0.00–20.00mA Pr. 03-28=2, 0.00–20.00mA	0.00 0.00 4.00
✓ 03-52	AVI proportional lowest point	-100.00–100.00%	0.00
✓ 03-53	AVI mid-point	Pr. 03-28=0, 0.00–10.00V Pr. 03-28=1, 0.00–20.00mA Pr. 03-28=2, 0.00–20.00mA	5.00 10.00 12.00
✓ 03-54	AVI proportional mid-point	-100.00–100.00%	50.00
✓ 03-55	AVI highest point	Pr. 03-28=0, 0.00–10.00V Pr. 03-28=1, 0.00–20.00mA Pr. 03-28=2, 0.00–20.00mA	10.00 20.00 20.00
✓ 03-56	AVI proportional high point	-100.00–100.00%	100.00
✓ 03-57	ACI lowest point	Pr. 03-29=0, 0.00–20.00mA Pr. 03-29=1, 0.00–10.00V Pr. 03-29=2, 0.00–20.00mA	4.00 0.00 0.00
✓ 03-58	ACI proportional lowest point	-100.00–100.00%	0.00

Pr.	Parameter Name	Setting Range	Default
✓ 03-59	ACI mid-point	Pr. 03-29=0, 0.00–20.00mA Pr. 03-29=1, 0.00–10.00V Pr. 03-29=2, 0.00–20.00mA	12.00 5.00 10.00
✓ 03-60	ACI proportional mid-point	-100.00–100.00%	50.00
✓ 03-61	ACI highest point	Pr. 03-29=0, 0.00–20.00mA Pr. 03-29=1, 0.00–10.00V Pr. 03-29=2, 0.00–20.00mA	20.00 10.00 20.00
✓ 03-62	ACI proportional highest point	-100.00–100.00%	100.00
✓ 03-63	Positive AUI voltage lowest point	0.00–10.00V	0.00
✓ 03-64	Positive AUI voltage proportional lowest point	-100.00%–100.00%	0.00
✓ 03-65	Positive AUI voltage mid-point	0.00–10.00V	5.00
✓ 03-66	Positive AUI voltage proportional mid-point	-100.00%–100.00%	50.00
✓ 03-67	Positive AUI voltage highest point	0.00–10.00V	10.00
✓ 03-68	Positive AUI voltage proportional highest point	-100.00%–100.00%	100.00
✓ 03-69	Negative AUI voltage highest point	-10.00V–0.00V	0.00
✓ 03-70	Negative AUI voltage proportional highest point	-100.00%–100.00%	0.00
✓ 03-71	Negative AUI voltage mid-point	-10.00–0.00V	-5.00
✓ 03-72	Negative AUI voltage proportional mid-point	-100.00%–100.00%	-50.00
✓ 03-73	Negative AUI voltage lowest point	-10.00–0.00V	-10.00
✓ 03-74	Negative AUI voltage proportional lowest point	-100.00%–100.00%	-100.00

## 04 Multi-step Speed Parameters

	Pr.	Parameter Name	Setting Range	Default
✓	04-00	1 <sup>st</sup> step speed frequency	0.00–599.00Hz	0.00
✓	04-01	2 <sup>nd</sup> step speed frequency	0.00–599.00Hz	0.00
✓	04-02	3 <sup>rd</sup> step speed frequency	0.00–599.00Hz	0.00
✓	04-03	4 <sup>th</sup> step speed frequency	0.00–599.00Hz	0.00
✓	04-04	5 <sup>th</sup> step speed frequency	0.00–599.00Hz	0.00
✓	04-05	6 <sup>th</sup> step speed frequency	0.00–599.00Hz	0.00
✓	04-06	7 <sup>th</sup> step speed frequency	0.00–599.00Hz	0.00
✓	04-07	8 <sup>th</sup> step speed frequency	0.00–599.00Hz	0.00
✓	04-08	9 <sup>th</sup> step speed frequency	0.00–599.00Hz	0.00
✓	04-09	10 <sup>th</sup> step speed frequency	0.00–599.00Hz	0.00
✓	04-10	11 <sup>th</sup> step speed frequency	0.00–599.00Hz	0.00
✓	04-11	12 <sup>th</sup> step speed frequency	0.00–599.00Hz	0.00
✓	04-12	13 <sup>th</sup> step speed frequency	0.00–599.00Hz	0.00
✓	04-13	14 <sup>th</sup> step speed frequency	0.00–599.00Hz	0.00
✓	04-14	15 <sup>th</sup> step speed frequency	0.00–599.00Hz	0.00
✓	04-15	Position command 1 (rotation)	-30000–30000	0
✓	04-16	Position command 1 (pulse)	-32767–32767	0
✓	04-17	Position command 2 (rotation)	-30000–30000	0
✓	04-18	Position command 2 (pulse)	-32767–32767	0
✓	04-19	Position command 3 (rotation)	-30000–30000	0
✓	04-20	Position command 3 (pulse)	-32767–32767	0
✓	04-21	Position command 4 (rotation)	-30000–30000	0
✓	04-22	Position command 4 (pulse)	-32767–32767	0
✓	04-23	Position command 5 (rotation)	-30000–30000	0
✓	04-24	Position command 5 (pulse)	-32767–32767	0
✓	04-25	Position command 6 (rotation)	-30000–30000	0
✓	04-26	Position command 6 (pulse)	-32767–32767	0
✓	04-27	Position command 7 (rotation)	-30000–30000	0
✓	04-28	Position command 7 (pulse)	-32767–32767	0
✓	04-29	Position command 8 (rotation)	-30000–30000	0
✓	04-30	Position command 8 (pulse)	-32767–32767	0
✓	04-31	Position command 9 (rotation)	-30000–30000	0
✓	04-32	Position command 9 (pulse)	-32767–32767	0
✓	04-33	Position command 10 (rotation)	-30000–30000	0
✓	04-34	Position command 10 (pulse)	-32767–32767	0
✓	04-35	Position command 11 (rotation)	-30000–30000	0
✓	04-36	Position command 11 (pulse)	-32767–32767	0

	Pr.	Parameter Name	Setting Range	Default
✓	04-37	Position command 12 (rotation)	-30000–30000	0
✓	04-38	Position command 12 (pulse)	-32767–32767	0
✓	04-39	Position command 13 (rotation)	-30000–30000	0
✓	04-40	Position command 13 (pulse)	-32767–32767	0
✓	04-41	Position command 14 (rotation)	-30000–30000	0
✓	04-42	Position command 14 (pulse)	-32767–32767	0
✓	04-43	Position command 15 (rotation)	-30000–30000	0
✓	04-44	Position command 15 (pulse)	-32767–32767	0
✓	04-50	PLC buffer 0	0–65535	0
✓	04-51	PLC buffer 1	0–65535	0
✓	04-52	PLC buffer 2	0–65535	0
✓	04-53	PLC buffer 3	0–65535	0
✓	04-54	PLC buffer 4	0–65535	0
✓	04-55	PLC buffer 5	0–65535	0
✓	04-56	PLC buffer 6	0–65535	0
✓	04-57	PLC buffer 7	0–65535	0
✓	04-58	PLC buffer 8	0–65535	0
✓	04-59	PLC buffer 9	0–65535	0
✓	04-60	PLC buffer 10	0–65535	0
✓	04-61	PLC buffer 11	0–65535	0
✓	04-62	PLC buffer 12	0–65535	0
✓	04-63	PLC buffer 13	0–65535	0
✓	04-64	PLC buffer 14	0–65535	0
✓	04-65	PLC buffer 15	0–65535	0
✓	04-66	PLC buffer 16	0–65535	0
✓	04-67	PLC buffer 17	0–65535	0
✓	04-68	PLC buffer 18	0–65535	0
✓	04-69	PLC buffer 19	0–65535	0
✓	04-70	PLC Application parameter 0	0–65535	0
✓	04-71	PLC Application parameter 1	0–65535	0
✓	04-72	PLC Application parameter 2	0–65535	0
✓	04-73	PLC Application parameter 3	0–65535	0
✓	04-74	PLC Application parameter 4	0–65535	0
✓	04-75	PLC Application parameter 5	0–65535	0
✓	04-76	PLC Application parameter 6	0–65535	0
✓	04-77	PLC Application parameter 7	0–65535	0
✓	04-78	PLC Application parameter 8	0–65535	0
✓	04-79	PLC Application parameter 9	0–65535	0
✓	04-80	PLC Application parameter 10	0–65535	0

	Pr.	Parameter Name	Setting Range	Default
✓	04-81	PLC Application parameter 11	0–65535	0
✓	04-82	PLC Application parameter 12	0–65535	0
✓	04-83	PLC Application parameter 13	0–65535	0
✓	04-84	PLC Application parameter 14	0–65535	0
✓	04-85	PLC Application parameter 15	0–65535	0
✓	04-86	PLC Application parameter 16	0–65535	0
✓	04-87	PLC Application parameter 17	0–65535	0
✓	04-88	PLC Application parameter 18	0–65535	0
✓	04-89	PLC Application parameter 19	0–65535	0
✓	04-90	PLC Application parameter 20	0–65535	0
✓	04-91	PLC Application parameter 21	0–65535	0
✓	04-92	PLC Application parameter 22	0–65535	0
✓	04-93	PLC Application parameter 23	0–65535	0
✓	04-94	PLC Application parameter 24	0–65535	0
✓	04-95	PLC Application parameter 25	0–65535	0
✓	04-96	PLC Application parameter 26	0–65535	0
✓	04-97	PLC Application parameter 27	0–65535	0
✓	04-98	PLC Application parameter 28	0–65535	0
✓	04-99	PLC Application parameter 29	0–65535	0

## 05 Motor Parameters

Pr.	Parameter Name	Setting Range	Default
05-00	Motor parameter auto tuning	0: No function 1: Simple rolling auto-tuning for induction motor (IM) 2: Static auto-tuning for induction motor (IM) 4: Dynamic test for PM magnetic pole (with the running in forward direction) 5: Rolling auto-tuning for PM (IPM / SPM) 6: Advanced rolling auto-tuning for IM motor flux curve 12: FOC sensorless inertia estimation 13: Static auto-tuning for PM (IPM / SPM)	0
05-01	Full-load current for induction motor 1 (A)	Depending on the model power	Depending on the model power
05-02	Rated power for induction motor 1 (kW)	0.00–655.35kW	Depending on the model power
05-03	Rated speed for induction motor 1 (rpm)	0–xxxx (Depending on the motor pole number)	Depending on the motor pole number
05-04	Number of poles for induction motor 1	2–64	4
05-05	No-load current for induction motor 1 (A)	0.00–Pr. 05-01 default	Depending on the model power
05-06	Stator resistance (Rs) for induction motor 1	0.000–65.535Ω	Depending on the model power
05-07	Rotor resistance (Rr) for induction motor 1	0.000–65.535Ω	0.000
05-08	Magnetizing inductance (Lm) for induction motor 1	0.0–6553.5mH	0.0
05-09	Stator inductance (Lx) for induction motor 1	0.0–6553.5mH	0.0
05-13	Full-load current for induction motor 2 (A)	Depending on the model power	Depending on the model power
05-14	Rated power for induction motor 2 (kW)	0.00–655.35kW	Depending on the model power
05-15	Rated speed for induction motor 2 (rpm)	0–xxxx (Depending on the motor pole number)	Depending on the motor pole number
05-16	Number of poles for induction motor 2	2–64	4
05-17	No-load current for induction motor 2 (A)	0.00– Pr. 05-13 default	Depending on the model power

Pr.	Parameter Name	Setting Range	Default
05-18	Stator resistance (Rs) for induction motor 2	0.000–65.535Ω	Depending on the model power
05-19	Rotor resistance (Rr) of induction motor 2	0.000–65.535Ω	0.000
05-20	Magnetizing inductance (Lm) of induction motor 2	0.0–6553.5mH	0.0
05-21	Stator inductance (Lx) of induction motor 2	0.0–6553.5mH	0.0
05-22	Induction motor 1 / 2 selection	1: Motor 1 2: Motor 2	1
✓ 05-23	Frequency for Y-connection / Δ-connection switch for an induction motor	0.00–599.00Hz	60.00
05-24	Y-connection / Δ-connection switch for induction motor	0: Disable 1: Enable	0
✓ 05-25	Delay time for Y-connection / Δ-connection switch for an induction motor	0.000–60.000 sec.	0.200
05-28	Accumulated Watt-hour for a motor (W-hour)	Read only	0.0
05-29	Accumulated Watt-hour for a motor in low word (kW-hour)	Read only	0.0
05-30	Accumulated Watt-hour for a motor in high word (MW-hour)	Read only	0
05-31	Accumulated motor operation time (Min.)	0–1439	0
05-32	Accumulated motor operation time (Day)	0–65535	0
05-33	Induction motor (IM) or permanent magnet motor (PM) selection	0: IM 1: SPM (Surface permanent magnet motor) 2: IPM (Interior permanent magnet motor)	0
05-34	Full-load current for a permanent magnet motor	Depending on the model power	Depending on the model power
✓ 05-35	Rated power for a permanent magnet motor	0.00–655.35kW	Depending on the model power
✓ 05-36	Rated speed for a permanent magnet motor	0–65535rpm	2000
05-37	Pole number for a permanent magnet motor	0–65535	10

Pr.	Parameter Name	Setting Range	Default
05-38	System inertia for a permanent magnet motor	0.0–6553.5kg.cm <sup>2</sup>	Depending on the motor power
05-39	Stator resistance for a permanent magnet motor	0.000–65.535Ω	0.000
05-40	Permanent magnet motor Ld	0.00–655.35mH	0.00
05-41	Permanent magnet motor Lq	0.00–655.35mH	0.00
✎ 05-42	PG offset angle for a permanent magnet motor	0.0–360.0°	0.0
✎ 05-43	Ke parameter of a permanent magnet motor	0–65535 (Unit: V / krpm)	0



## 06 Protection Parameters

Pr.	Parameter Name	Setting Range	Default
↗ 06-00	Low voltage level	230V: Frame A–D: 150.0–220.0V <sub>DC</sub> Frame E and above: 190.0–220.0V <sub>DC</sub> 460V: Frame A–D: 300.0–440.0V <sub>DC</sub> Frame E and above: 380.0–440.0V <sub>DC</sub> 575V: 420.0–520.0V <sub>DC</sub> 690V: 450.0–660.0V <sub>DC</sub>	180.0 200.0 360.0 400.0 470.0 480.0
↗ 06-01	Over-voltage stall prevention	0: Disabled 230V: 0.0–450.0V <sub>DC</sub> 460V: 0.0–900.0V <sub>DC</sub> 575V: 0.0–920.0V <sub>DC</sub> 690V: 0.0–1087.0V <sub>DC</sub>	380.0 760.0 920.0 1087.0
↗ 06-02	Selection for over-voltage stall prevention	0: Traditional over-voltage stall prevention 1: Smart over-voltage stall prevention	0
↗ 06-03	Over-current stall prevention during acceleration	<b>230V / 460V models</b> Normal load: 0–160% (100% corresponds to the rated current of the drive) Heavy load: 0–180% (100% corresponds to the rated current of the drive) <b>575V / 690V models</b> Light load: 0–125% (100% corresponds to the rated current of the drive) Normal load: 0–150% (100% corresponds to the rated current of the drive) Heavy load: 0–180% (100% corresponds to the rated current of the drive)	120 120 120 120 150
↗ 06-04	Over-current stall prevention during operation	<b>230V / 460V models</b> Normal load: 0–160% (100% corresponds to the rated current of the drive) Heavy load: 0–180% (100% corresponds to the rated current of the drive) <b>575V / 690V models</b> Light load: 0–125% (100% corresponds to the rated current of the drive) Normal load: 0–150% (100% corresponds to the rated current of the drive) Heavy load: 0–180% (100% corresponds to the rated current of the drive)	120 120 120 120 150

Pr.	Parameter Name	Setting Range	Default
↗ 06-05	Acceleration / deceleration time selection for stall prevention at constant speed	0: By current acceleration / deceleration time 1: By the 1 <sup>st</sup> acceleration / deceleration time 2: By the 2 <sup>nd</sup> acceleration / deceleration time 3: By the 3 <sup>rd</sup> acceleration / deceleration time 4: By the 4 <sup>th</sup> acceleration / deceleration time 5: By automatic acceleration / deceleration	0
↗ 06-06	Over-torque detection selection (OT1)	0: No function 1: Continue operation after over-torque detection during constant speed operation 2: Stop after over-torque detection during constant speed operation 3: Continue operation after over-torque detection during RUN 4: Stop after over-torque detection during RUN	0
↗ 06-07	Over-torque detection level (OT1)	10–250% (100% corresponds to the rated current of the drive)	120
↗ 06-08	Over-torque detection time (OT1)	0.0–60.0 sec.	0.1
↗ 06-09	Over-torque detection selection (OT2)	0: No function 1: Continue operation after over-torque detection during constant speed operation 2: Stop after over-torque detection during constant speed operation 3: Continue operation after over-torque detection during RUN 4: Stop after Over-torque detection during RUN	0
↗ 06-10	Over-torque detection level (OT2)	10–250% (100% corresponds to the rated current of the drive)	120
↗ 06-11	Over-torque detection time (OT2)	0.0–60.0 sec.	0.1
↗ 06-12	Current limit	0–250% (100% corresponds to the rated current of the drive)	170
↗ 06-13	Electronic thermal relay selection 1 (Motor 1)	0: Inverter motor (with external forced cooling) 1: Standard motor (motor with fan on the shaft) 2: Disable	2
↗ 06-14	Electronic thermal relay action time 1 (Motor 1)	30.0–600.0 sec.	60.0
↗ 06-15	Temperature level over-heat (OH) warning	0.0–110.0°C	105.0
↗ 06-16	Stall prevention limit level (Weak magnetic area current stall prevention level)	0–100% (Pr. 06-03, Pr. 06-04)	100

Pr.	Parameter Name	Setting Range	Default
06-17	Fault record 1 (Present fault record)	0: No fault record 1: Over-current during acceleration (ocA)	0
06-18	Fault record 2	2: Over-current during deceleration (ocd)	0
06-19	Fault record 3	3: Over-current during constant speed (ocn)	0
06-20	Fault record 4	4: Ground fault (GFF)	0
06-21	Fault record 5	5: IGBT short-circuit (occ)	0
06-22	Fault record 6	6: Over-current at stop (ocS)	0
		7: Over-voltage during acceleration (ovA) 8: Over-voltage during deceleration (ovd) 9: Over-voltage during constant speed (ovn) 10: Over-voltage at stop (ovS) 11: Low-voltage during acceleration (LvA) 12: Low-voltage during deceleration (Lvd) 13: Low-voltage during constant speed (Lvn) 14: Low-voltage at stop (LvS) 15: Phase loss protection (OrP) 16: IGBT over-heat (oH1) 17: Capacitance over-heat (oH2) 18: TH1 open: IGBT over-heat protection error (tH1o) 19: TH2 open: capacitance over-heat protection error (tH2o) 21: Drive over-load (oL) 22: Electronics thermal relay protection 1 (EoL1) 23: Electronics thermal relay protection 2 (EoL2) 24: Motor overheat (oH3) (PTC / PT100) 26: Over-torque 1 (ot1) 27: Over-torque 2 (ot2) 28: Low current (uC) 29: Home limit error (LMIT) 30: Memory write-in error (cF1) 31: Memory read-out error (cF2)	
		33: U-phase current detection error (cd1) 34: V-phase current detection error (cd2) 35: W-phase current detection error (cd3) 36: Clamp current detection error (Hd0) 37: Over-current detection error (Hd1) 38: Over-voltage detection error (Hd2) 39: IGBT short-circuit detection error (Hd3) 40: Auto-tuning error (AUE) 41: PID feedback loss (AFE)	

Pr.	Parameter Name	Setting Range	Default
		42: PG feedback error (PGF1)	
		43: PG feedback loss (PGF2)	
		44: PG feedback stall (PGF3)	
		45: PG slip error (PGF4)	
		48: Analog current input loss (ACE)	
		49: External fault input (EF)	
		50: Emergency stop (EF1)	
		51: External base block (bb)	
		52: Password error (Pcod)	
		54: Communication error (CE1)	
		55: Communication error (CE2)	
		56: Communication error (CE3)	
		57: Communication error (CE4)	
		58: Communication time-out (CE10)	
		60: Brake transistor error (bF)	
		61: Y-connection / $\Delta$ -connection switch error (ydc)	
		62: Deceleration energy backup error (dEb)	
		63: Slip error (oSL)	
		64: Electromagnet switch error (ryF)	
		65: PG card error (PGF5)	
		68: Sensorless estimated speed have wrong direction	
		69: Sensorless estimated speed is over speed	
		70: Sensorless estimated speed deviated	
		71: Watchdog	
		72: Channel 1 (STO1~SCM1) safety loop error (STL1)	
		73: External safety gate (S1)	
		75: External brake error	
		76: Safe torque off (STO)	
		77: Channel 2 (STO2~SCM2) safety loop error (STL2)	
		78: Internal loop error (STL3)	
		82: U phase output phase loss (OPHL)	
		83: V phase output phase loss (OPHL)	
		84: W phase output phase loss (OPHL)	
		85: PG-02U ABZ hardware disconnection	
		86: PG-02U UVW hardware disconnection	
		87: oL3 Low frequency overload protection	
		89: RoPd Initial rotor position detection error	
		90: Inner PLC function is forced to stop	
		93: CPU error	
		101: CANopen software disconnect 1 (CGdE)	
		102: CAN open software disconnect 2 (CHbE)	

Pr.	Parameter Name	Setting Range	Default	
		104: CANopen hardware disconnect (CbFE) 105: CANopen index setting error (CIdE) 106: CANopen slave station number setting error (CAde) 107: CANopen index setting exceed limit (CFrE) 111: ictE Internal communication overtime error (InrCOM) 112: PM sensorless shaft lock error 142: Auto-tuning error 1 (no feedback current error) (AUE1) 143: Auto-tuning error 2 (motor phase loss error) (AUE2) 144: Auto-tuning error 3 (no-load current I <sub>0</sub> measuring error) (AUE3) 148: Auto-tuning error 4 (leakage inductance L <sub>sigma</sub> measuring error) (AUE4)		
✓	06-23	Fault output option 1	0–65535 (refer to bit table for fault code)	0
✓	06-24	Fault output option 2	0–65535 (refer to bit table for fault code)	0
✓	06-25	Fault output option 3	0–65535 (refer to bit table for fault code)	0
✓	06-26	Fault output option 4	0–65535 (refer to bit table for fault code)	0
✓	06-27	Electronic thermal relay selection 2 (Motor 2)	0: Inverter motor (with external forced cooling) 1: Standard motor (motor with fan on the shaft) 2: Disable	2
✓	06-28	Electronic thermal relay action time 2 (Motor 2)	30.0–600.0 sec.	60.0
✓	06-29	PTC detection selection / PT100 motion	0: Warn and continue operation 1: Warn and ramp to stop 2: Warn and coast to stop 3: No warning	0
✓	06-30	PTC level / KTY84 Level	0.0–100.0%	50.0
	06-31	Frequency command at malfunction	0.00–599.00Hz	Read only
	06-32	Output frequency at malfunction	0.00–599.00Hz	Read only
	06-33	Output voltage at malfunction	0.0–6553.5V	Read only
	06-34	DC voltage at malfunction	0.0–6553.5V	Read only
	06-35	Output current at malfunction	0.0–6553.5Amp	Read only

Pr.	Parameter Name	Setting Range	Default
06-36	IGBT temperature at malfunction	-3276.7–3276.7°C	Read only
06-37	Capacitance temperature at malfunction	-3276.7–3276.7°C	Read only
06-38	Motor speed at malfunction	-32767–32767rpm	Read only
06-39	Torque command at malfunction	-32767–32767%	Read only
06-40	Status of the multi-function input terminal at malfunction	0000h–FFFFh	Read only
06-41	Status of the multi-function output terminal at malfunction	0000h–FFFFh	Read only
06-42	Drive status at malfunction	0000h–FFFFh	Read only
↗ 06-44	STO latch selection	0: STO latch 1: STO no latch	0
↗ 06-45	Treatment to output phase loss protection (OPHL)	0: Warn and continue operation 1: Warn and ramp to stop 2: Warn and coast to stop 3: No warning	3
↗ 06-46	Detection time of output phase loss	0.000–65.535 sec.	3.000
↗ 06-47	Current detection level for output phase loss	0.00–100.00%	1.00
↗ 06-48	DC brake time of output phase loss	0.000–65.535 sec.	0.000
↗ 06-49	LvX auto-reset	0: Disable 1: Enable	0
↗ 06-50	Time for input phase loss detection	0.00–600.00 sec.	0.20
06-51	CAP oH warning level	0.0–110.0 degree	Depending on the motor power
↗ 06-52	Ripple of input phase loss	230V series: 0.0–160.0V <sub>DC</sub> 460V series: 0.0–320.0V <sub>DC</sub> 575V series: 0.0–400.0V <sub>DC</sub> 690V series: 0.0–480.0V <sub>DC</sub>	30.0 60.0 75.0 90.0
↗ 06-53	Detected input phase loss (OrP) action	0: Warn and ramp to stop 1: Warn and coast to stop	0
↗ 06-55	Derating protection	0: Constant rated current and limit carrier wave by load current and temperature	0

Pr.	Parameter Name	Setting Range	Default
		1: Constant carrier frequency and limit load current by setting carrier wave 2: Constant rated current (same as setting 0), but close current limit	
✎ 06-56	PT100 voltage level 1	0.000–10.000V	5.000
✎ 06-57	PT100 voltage level 2	0.000–10.000V	7.000
✎ 06-58	PT100 level 1 frequency protect	0.00–599.00Hz	0.00
✎ 06-59	PT100 activation level 1 protect frequency delay time	0–6000 sec.	60
✎ 06-60	Software detection GFF current level	0.0–6553.5 %	60.0
✎ 06-61	Software detection GFF filter time	0.00–655.35 sec.	0.10
06-62	dEb reset bias level	230V: 0.0–100 V <sub>DC</sub> 460V: 0.0–200.0 V <sub>DC</sub>	20.0 40.0
06-63	Operation time of fault record 1 (Day)	0–65535 days	Read only
06-64	Operation time of fault record 1 (Minutes)	0–1439 min.	Read only
06-65	Operation time of fault record 2 (Day)	0–65535 days	Read only
06-66	Operation time of fault record 2 (Minutes)	0–1439 min.	Read only
06-67	Operation time of fault record 3 (Day)	0–65535 days	Read only
06-68	Operation time of fault record 3 (Minutes)	0–1439 min.	Read only
06-69	Operation time of fault record 4 (Day)	0–65535 days	Read only
06-70	Operation time of fault record 4 (Minutes)	0–1439 min.	Read only
✎ 06-71	Low current setting level	0.0–100.0 %	0.0
✎ 06-72	Low current detection time	0.00–360.00 sec.	0.00
✎ 06-73	Low current action	0: No function 1: Warn and coast to stop 2: Warn and ramp to stop by the 2 <sup>nd</sup> deceleration time 3: Warn and continue operation	0
06-86	PTC Type	0–1 0: PTC 1: KTY84-130	0

## 07 Special Parameters

Pr.	Parameter Name	Setting Range	Default
✓ 07-00	Built-in software brake level	230V: 350.0–450.0V <sub>DC</sub> 460V: 700.0–900.0V <sub>DC</sub> 575V: 850.0–1116.0V <sub>DC</sub> 690V: 939.0–1318.0V <sub>DC</sub>	370.0 740.0 895.0 1057.0
✓ 07-01	DC brake current level	0–100%	0
✓ 07-02	DC brake time at run	0.0–60.0 sec.	0.0
✓ 07-03	DC brake time at stop	0.0–60.0 sec.	0.0
✓ 07-04	DC brake frequency at stop	0.00–599.00Hz	0.00
✓ 07-05	Voltage increasing gain	1–200%	100
✓ 07-06	Restart after momentary power loss	0: Stop operation 1: Speed tracking by speed before the power loss 2: Speed tracking by minimum output frequency	0
✓ 07-07	Allowed power loss duration	0.0–20.0 sec.	2.0
✓ 07-08	Base block time	0.0–5.0 sec.	##
✓ 07-09	Current limit of speed tracking	20–200%	100
✓ 07-10	Restart after fault action	0: Stop operation 1: Speed tracking by current speed 2: Speed tracking by minimum output frequency	0
✓ 07-11	Number of times of restart after fault	0–10	0
✓ 07-12	Speed tracking during start-up	0: Disable 1: Speed tracking by maximum output frequency 2: Speed tracking by motor frequency at start 3: Speed tracking by minimum output frequency	0
✓ 07-13	dEb function selection	0: Disable 1: dEb with auto-acceleration / auto-deceleration, the drive does not output the frequency after the power is restored. 2: dEb with auto-acceleration / auto-deceleration, the drive outputs the frequency after the power is restored 3: dEb low-voltage control, then increase to 350V <sub>DC</sub> / 700V <sub>DC</sub> and decelerate to stop 4: dEb high-voltage control of 350V <sub>DC</sub> / 700V <sub>DC</sub> and decelerate to stop	0
07-14	dEb function reset time	0.0–25.0 sec.	3.0
✓ 07-15	Dwell time at acceleration	0.00–600.00 sec.	0.00
✓ 07-16	Dwell frequency at acceleration	0.00–599.00Hz	0.00
✓ 07-17	Dwell time at deceleration	0.00–600.00 sec.	0.00
✓ 07-18	Dwell frequency at deceleration	0.00–599.00Hz	0.00



Pr.	Parameter Name	Setting Range	Default
✓ 07-19	Fan cooling control	0: Fan always ON 1: Fan is OFF after AC motor drive stops for one minute 2: Fan is ON when AC motor drive runs; fan is OFF when AC motor drive stops. 3: Fan turns ON when temperature (IGBT) reaches around 60°C. 4: Fan always OFF	0
✓ 07-20	Emergency stop (EF) & force to stop selection	0: Coast to stop 1: Stop by the 1 <sup>st</sup> deceleration time 2: Stop by the 2 <sup>nd</sup> deceleration time 3: Stop by the 3 <sup>rd</sup> deceleration time 4: Stop by the 4 <sup>th</sup> deceleration time 5: System deceleration 6: Automatic deceleration	0
✓ 07-21	Automatic energy-saving selection	0: Disable 1: Enable	0
✓ 07-22	Energy-saving gain	10~1000%	100
✓ 07-23	Auto voltage regulation (AVR) function	0: Enable AVR 1: Disable AVR 2: Disable AVR during deceleration	0
✓ 07-24	Torque command filter time (V/F and SVC control mode)	0.001–10.000 sec.	0.500
✓ 07-25	Slip compensation filter time (V/F and SVC control mode)	0.001–10.000 sec.	0.100
✓ 07-26	Torque compensation gain (V/F and SVC control mode)	IM: 0–10 (when Pr. 05-33 = 0) PM: 0–5000 (when Pr. 05-33 = 1 or 2)	0
✓ 07-27	Slip compensation gain (V/F and SVC control mode)	0.00–10.00	0.00 (Default value is 1.00 in SVC mode)
✓ 07-29	Slip deviation level	0.0–100.0% 0: No detection	0
✓ 07-30	Over slip deviation detection time	0.0–10.0 sec.	1.0
✓ 07-31	Over slip deviation treatment	0: Warn and continue operation 1: Warn and ramp to stop 2: Warn and coast to stop 3: No warning	0
✓ 07-32	Motor shock compensation factor	0–10000 0: Disable	1000
✓ 07-33	Auto-restart internal of fault	0.0–6000.0 sec.	60.0

Pr.	Parameter Name	Setting Range	Default
07-38	PMSVC voltage feedback forward gain	0.50–2.00	1.00
07-62	dEb gain (Kp)	0–65535	8000
07-63	dEb gain (Ki)	0–65535	150

## 08 High-function PID Parameters

Pr.	Parameter Name	Setting Range	Default
✓ 08-00	Terminal selection of PID feedback	0: No function 1: Negative PID feedback: by analog input (Pr. 03-00-03-02) 2: Negative PID feedback: by PG card pulse input, without direction (Pr. 10-02) 3: Negative PID feedback: by PG card pulse input, with direction (Pr. 10-02) 4: Positive PID feedback: by analog input (Pr. 03-00-03-02) 5: Positive PID feedback: by PG card pulse input, without direction (Pr. 10-02) 6: Positive PID feedback: by PG card pulse input, with direction (Pr. 10-02) 7: Negative PID feedback: by communication protocol 8: Positive PID feedback: by communication protocol	0
✓ 08-01	Proportional gain (P)	0.0–500.0	1.0
✓ 08-02	Integral time (I)	0.00–100.00 sec. 0.0: No integral	1.00
✓ 08-03	Differential time (D)	0.00–1.00 sec.	0.00
✓ 08-04	Upper limit of integral control	0.0–100.0%	100.0
✓ 08-05	PID output command limit	0.0–110.0%	100.0
✓ 08-06	PID feedback value by communication protocol	-200.00–200.00%	Read only
✓ 08-07	PID delay time	0.0–35.0 sec.	0.0
✓ 08-08	Feedback signal detection time	0.0–3600.0 sec.	0.0
✓ 08-09	Feedback signal fault treatment	0: Warn and continue operation 1: Warn and ramp to stop 2: Warn and coast to stop 3: Warn and operate at last frequency	0
✓ 08-10	Sleep frequency	0.00–599.00Hz	0.00
✓ 08-11	Wake-up frequency	0.00–599.00Hz	0.00
✓ 08-12	Sleep time	0.0–6000.0 sec.	0.0
✓ 08-13	PID deviation level	1.0–50.0%	10.0
✓ 08-14	PID deviation time	0.1–300.0 sec.	5.0
✓ 08-15	PID feedback filter time	0.1–300.0 sec.	5.0
✓ 08-16	PID compensation selection	0: Parameter setting (Pr. 08-17) 1: Analog input	0
✓ 08-17	PID compensation	-100.0–100.0%	0.0

Pr.	Parameter Name	Setting Range	Default
08-18	Sleep mode function setting	0: Refer to PID output command 1: Refer to PID feedback signal	0
✓ 08-19	Wake-up integral limit	0.0–200.0%	50.0
08-20	PID mode selection	0: Serial connection 1: Parallel connection	0
08-21	Enable PID to change the operation direction	0: Operation direction cannot be changed 1: Operation direction can be changed	0
✓ 08-22	Wake-up delay time	0.00–600.00 sec.	0.00
✓ 08-23	PID control flag	bit0 = 1, PID running in reverse follows the setting for Pr. 00-23. bit0 = 0, PID running in reverse follows PID's calculated value. bit1 = 1, second decimal place of PID Kp bit1 = 0, first decimal place of PID Kp	0000h

## 09 Communication Parameters

	Pr.	Parameter Name	Setting Range	Default
↗	09-00	Communication address	1–254	1
↗	09-01	COM1 transmission speed	4.8–115.2Kbps	9.6
↗	09-02	COM1 transmission fault treatment	0: Warn and continue operation 1: Warn and ramp to stop 2: Warn and coast to stop 3: No warning and continue operation	3
↗	09-03	COM1 time-out detection	0.0–100.0 sec.	0.0
↗	09-04	COM1 communication protocol	1 : 7, N, 2 (ASCII) 2 : 7, E, 1 (ASCII) 3 : 7, O, 1 (ASCII) 4 : 7, E, 2 (ASCII) 5 : 7, O, 2 (ASCII) 6 : 8, N, 1 (ASCII) 7 : 8, N, 2 (ASCII) 8 : 8, E, 1 (ASCII) 9 : 8, O, 1 (ASCII) 10 : 8, E, 2 (ASCII) 11 : 8, O, 2 (ASCII) 12: 8, N, 1 (RTU) 13: 8, N, 2 (RTU) 14: 8, E, 1 (RTU) 15: 8, O, 1 (RTU) 16: 8, E, 2 (RTU) 17: 8, O, 2 (RTU)	1
↗	09-09	Communication response delay time	0.0–200.0ms	2.0
	09-10	Communication main frequency	0.00–599.00Hz	60.00
↗	09-11	Block transfer 1	0000–FFFFh	0000h
↗	09-12	Block transfer 2	0000–FFFFh	0000h
↗	09-13	Block transfer 3	0000–FFFFh	0000h
↗	09-14	Block transfer 4	0000–FFFFh	0000h
↗	09-15	Block transfer 5	0000–FFFFh	0000h
↗	09-16	Block transfer 6	0000–FFFFh	0000h
↗	09-17	Block transfer 7	0000–FFFFh	0000h
↗	09-18	Block transfer 8	0000–FFFFh	0000h
↗	09-19	Block transfer 9	0000–FFFFh	0000h
↗	09-20	Block transfer 10	0000–FFFFh	0000h
↗	09-21	Block transfer 11	0000–FFFFh	0000h
↗	09-22	Block transfer 12	0000–FFFFh	0000h

Pr.	Parameter Name	Setting Range	Default	
✓	09-23	Block transfer 13	0000–FFFFh	0000h
✓	09-24	Block transfer 14	0000–FFFFh	0000h
✓	09-25	Block transfer 15	0000–FFFFh	0000h
✓	09-26	Block transfer 16	0000–FFFFh	0000h
	09-30	Communication decoding method	0: Decoding method 1 (20xx) 1: Decoding method 2 (60xx)	1
	09-31	Internal communication protocol	0: MODBUS 485 -1: Internal communication slave 1 -2: Internal communication slave 2 -3: Internal communication slave 3 -4: Internal communication slave 4 -5: Internal communication slave 5 -6: Internal communication slave 6 -7: Internal communication slave 7 -8: Internal communication slave 8 -10: Internal communication master -12: Internal PLC control	0
✓	09-33	PLC command force to 0	bit0: Before PLC scans, set up PLC target frequency=0 bit1: Before PLC scans, set up PLC target torque=0 bit2: Before PLC scans, set up the speed limit of torque control mode=0	0
	09-35	PLC address	1–254	2
	09-36	CANopen slave address	0: Disable 1–127	0
	09-37	CANopen speed	0: 1Mbps 1: 500Kbps 2: 250Kbps 3: 125Kbps 4: 100Kbps (Delta only) 5: 50Kbps	0
	09-39	CANopen warning record	bit0: CANopen Guarding Time out bit1: CANopen Heartbeat Time out bit2: CANopen SYNC Time out bit3: CANopen SDO Time out bit4: CANopen SDO buffer overflow bit5: Can Bus Off bit6: Error protocol of CANopen	Read only

Pr.	Parameter Name	Setting Range	Default
		bit8: The setting values of CANopen indexes are fail bit9: The setting value of CANopen address is fail bit10: The checksum value of CANopen indexes is fail	
09-40	CANopen decoding method	0: Disable (Delta-defined decoding method) 1: Enable (CANopen DS402 standard protocol)	1
09-41	CANopen communication status	0: Node Reset 1: Com Reset 2: Boot up 3: Pre operation 4: Operation 5: Stop	Read Only
09-42	CANopen control status	0: Not ready for use 1: Inhibit Start 2: Ready to Switch on 3: Switched on 4: Enable Operation 7: Quick Stop Active 13: Error Reaction Activation 14: Error	Read Only
09-45	CANopen master function	0: Disable 1: Enable	0
09-46	CANopen master address	0–127	100
09-60	Communication card identification	0–12 0: No communication card 1: DeviceNet Slave 2: Profibus-DP Slave 3: CANopen Slave / Master 4: MODBUS-TCP Slave 5: EtherNet / IP Slave 6: EtherCAT 12: PROFINET	##
09-61	Firmware version of communication card	Read only	##
09-62	Product code	Read only	##
09-63	Error code	Read only	##
09-70	Communication card address (for DeviceNet or PROFIBUS)	DeviceNet: 0–63 Profibus-DP: 1–125	1

↗

Pr.	Parameter Name	Setting Range	Default
✎ 09-71	Communication card speed setting (for DeviceNet)	Standard DeviceNet: 0: 125Kbps 1: 250Kbps 2: 500Kbps 3: 1Mbps (Delta only) Non-standard DeviceNet: (Delta only) 0: 10Kbps 1: 20Kbps 2: 50Kbps 3: 100Kbps 4: 125Kbps 5: 250Kbps 6: 500Kbps 7: 800Kbps 8: 1Mbps	2
✎ 09-72	Other communication card speed setting (for DeviceNet)	0: Standard DeviceNet In this mode, baud rate can only be 125Kbps, 250Kbps, 500Kbps in standard DeviceNet speed 1: Non-standard DeviceNet In this mode, the baud rate of DeviceNet can be the same as CANopen (0~8).	0
✎ 09-75	Communication card IP configuration (for MODBUS TCP)	0: Static IP 1: Dynamic IP (DHCP)	0
✎ 09-76	Communication card IP address 1 (for MODBUS TCP)	0-65535	0
✎ 09-77	Communication card IP address 2 (for MODBUS TCP)	0-65535	0
✎ 09-78	Communication card IP address 3 (for MODBUS TCP)	0-65535	0
✎ 09-79	Communication card IP address 4 (for MODBUS TCP)	0-65535	0
✎ 09-80	Communication card address mask 1 (for MODBUS TCP)	0-65535	0
✎ 09-81	Communication card address mask 2 (for MODBUS TCP)	0-65535	0
✎ 09-82	Communication card address mask 3 (for MODBUS TCP)	0-65535	0
✎ 09-83	Communication card address mask 4 (for MODBUS TCP)	0-65535	0



Pr.	Parameter Name	Setting Range	Default
09-84	Communication card gateway address 1 (for MODBUS TCP)	0–65535	0
09-85	Communication card gateway address 2 for MODBUS TCP)	0–65535	0
09-86	Communication card gateway address 3 (for MODBUS TCP)	0–65535	0
09-87	Communication card gateway address 4 (for MODBUS TCP)	0–65535	0
09-88	Communication card password (Low word) (for MODBUS TCP)	0–99	0
09-89	Communication card password (High word) (for MODBUS TCP)	0–99	0
09-90	Reset communication card (for MODBUS TCP)	0: Disable 1: Reset, return to default	0
09-91	Additional settings for the communication card (for MODBUS TCP)	bit0: Enable IP filter bit 1: Enable internet parameters (1 bit). When IP address is set, this bit is enabled. After updating the communication card parameters, this bit changes to disabled. bit 2: Enable login password (1 bit). When you enter the login password, this bit is enabled. After updating the communication card parameters, this bit changes to disabled.	0
09-92	Communication card status (for MODBUS TCP)	bit0: Enable password When the communication card is set with a password, this bit is enabled. When the password is cleared, this bit is disabled.	0

## 10 Feedback Control Parameters

 **NOTE** IM: Induction Motor; PM: Permanent Magnet Motor

Pr.	Parameter Name	Setting Range	Default
10-00	Encoder type selection	0: Disable 1: ABZ 2: ABZ (Delta encoder for Delta servo motor) 3: Resolver 4: ABZ / UVW 5: MI8 single phase pulse input	0
10-01	Encoder pulses per revolution	1–20000	600
10-02	Encoder input type setting	0: Disable 1: Phases A and B are pulse inputs, forward direction if A-phase leads B-phase by 90 degrees 2: Phases A and B are pulse inputs, forward direction if B-phase leads A-phase by 90 degrees 3: Phase A is a pulse input and phase B is a direction input (L = reverse direction, H = forward direction) 4: Phase A is a pulse input and phase B is a direction input (L = forward direction, H = reverse direction) 5: Single-phase input	0
✓ 10-03	Frequency division output setting (denominator)	1–255	1
✓ 10-04	Electrical gear at load side A1	1–65535	100
✓ 10-05	Electrical gear at motor side B1	1–65535	100
✓ 10-06	Electrical gear at load side A2	1–65535	100
✓ 10-07	Electrical gear at motor side B2	1–65535	100
✓ 10-08	Treatment for encoder / speed observer feedback fault	0: Warn and continue operation 1: Warn and ramp to stop 2: Warn and coast to stop	2
✓ 10-09	Detection time of encoder / speed observer feedback fault	0.0–10.0 sec. 0: Disable	1.0
✓ 10-10	Encoder / speed observer stall level	0–120% 0: No function	115
✓ 10-11	Detection time of encoder / speed observer stall	0.0–2.0 sec.	0.1
✓ 10-12	Encoder / speed observer stall action	0: Warn and continue operation 1: Warn and ramp to stop 2: Warn and coast to stop	2
✓ 10-13	Encoder / speed observer slip range	0–50% 0: No function	50

	Pr.	Parameter Name	Setting Range	Default
✓	10-14	Detection time of encoder / speed observer slip	0.0–10.0 sec.	0.5
✓	10-15	Encoder / speed observer stall and slip error action	0: Warn and continue operation 1: Warn and ramp to stop 2: Warn and coast to stop	2
✓	10-16	Pulse input type setting	0: Disable 1: Phases A and B are pulse inputs, forward direction if A-phase leads B-phase by 90 degrees 2: Phases A and B are pulse inputs, forward direction if B-phase leads A-phase by 90 degrees 3: Phase A is a pulse input and phase B is a direction input (L = reverse direction, H = forward direction). 4: Phase A is a pulse input and phase B is a direction input. (L = forward direction, H = reverse direction). 5: Single-phase pulse input (MI8)	0
✓	10-17	Electrical gear A	1–65535	100
✓	10-18	Electrical gear B	1–65535	100
✓	10-19	Positioning for encoder position	-32767–2400	0
✓	10-20	Error range for encoder position reached	0–65535 pulses	10
✓	10-21	Filter time (PG2)	0.000–65.535 sec.	0.100
✓	10-24	FOC & TQC function control	bit0: ASR control at sensorless torque (0: use PI as ASR; 1: use P as ASR) bit11: Activate DC braking when executing zero torque command (0: ON; 1: OFF) bit12: FOC Sensorless mode, cross zero means speed goes from negative to positive or reverse direction (0: determined by stator frequency; 1: determined by speed command) bit15: Direction control at open loop status (0: Switch ON direction control; 1: Switch OFF direction control)	0
✓	10-25	FOC bandwidth for speed observer	20.0–100.0Hz	40.0
✓	10-26	FOC minimum stator frequency	0.0–10.0%fN	2.0
✓	10-27	FOC low-pass filter time constant	1–1000ms	50
✓	10-28	FOC gain for excitation current rise time	33–100%Tr	100
✓	10-29	Top limit of frequency deviation	0.00–200.00Hz	20.00

Pr.	Parameter Name	Setting Range	Default
	Resolver pole pair	1–50 pole pairs	1
✓	I/F mode, current command	0–150% of motor rated current	40
✓	PM FOC sensorless speed estimator bandwidth	0.00–600.00Hz	5.00
✓	PM sensorless speed estimator low-pass filter gain	0.00–655.35	1.00
✓	AMR (Kp) gain	0.00–3.00	1.00
✓	AMR (Ki) gain	0.00–3.00	0.20
✓	PM sensorless control word	0000–FFFFh	0000
✓	Frequency point to switch from I/F mode to PM sensorless mode	0.00–599.00Hz	20.00
✓	Frequency point to switch from PM sensorless mode to V/F mode	0.00–599.00Hz	20.00
✓	I/F mode, Id current low pass-filter time	0.0–6.0 sec.	0.2
✓	Initial angle detection pulse value	0.0–3.0	1.0
	PG card version	0–655.35	Read only
✓	Zero voltage time during start-up	0.000–60.000 sec.	0.000
✓	Reverse angle limit (Electrical angle)	0.00–30.00 degree	10.00
✓	Injection frequency	0–1200Hz	500
✓	Injection magnitude	0.0–200.0V 230V Series: 0.0–100.0V 460V Series: 0.0–200.0V 575V Series: 0.0–200.0V 690V Series: 0.0–200.0V	15.0 30.0 30.0 30.0
✓	PM initial rotor position detection method	0: Disable 1: Internal 1/4 rated current attracting the rotor to zero degrees 2: High frequency injection 3: Pulse injection	0

## 11 Advanced Parameters

Pr.	Parameter Name	Setting Range	Default
11-00	System control	bit0: Auto-tuning for ASR and APR bit1: Inertia estimate (only in FOCPG mode) bit2: Zero servo bit6: 0Hz linear-cross bit7: Save or do not save the frequency bit8: Maximum speed for point to point position control	0000h
11-01	Per unit of system inertia	1–65535 (256 = 1PU)	256
↗ 11-02	ASR1 / ASR2 switch frequency	5.00–599.00Hz	7.00
↗ 11-03	ASR1 low-speed bandwidth	1–40Hz (IM) / 1~100Hz (PM)	10
↗ 11-04	ASR2 high-speed bandwidth	1–40Hz (IM) / 1~100Hz (PM)	10
↗ 11-05	Zero-speed bandwidth	1–40Hz (IM) / 1~100Hz (PM)	10
↗ 11-06	ASR 1 gain	0–40Hz (IM) / 1~100Hz (PM)	10
↗ 11-07	ASR 1 integral time	0.000–10.000 sec.	0.100
↗ 11-08	ASR 2 gain	0–40Hz (IM) / 0~100Hz (PM)	10
↗ 11-09	ASR 2 integral time	0.000–10.000 sec.	0.100
↗ 11-10	ASR gain of zero speed	0–40Hz (IM) / 0~100Hz (PM)	10
↗ 11-11	ASR1 integral time of zero speed	0.000–10.000 sec.	0.100
↗ 11-12	Gain for ASR speed feed forward	0–150%	0
↗ 11-13	PDFF gain value	0–200%	30
↗ 11-14	ASR output Low-pass filter time	0.000–0.350 sec.	0.008
↗ 11-15	Notch filter depth	0–20db	0
↗ 11-16	Notch filter frequency	0.00–200.00Hz	0.00
↗ 11-17	Forward motor torque limit Quadrant I	0–500%	500
↗ 11-18	Forward regenerative torque limit Quadrant II	0–500%	500
↗ 11-19	Reverse motor torque limit Quadrant III	0–500%	500
↗ 11-20	Reverse regenerative torque limit Quadrant IV	0–500%	500
↗ 11-21	Flux weakening curve for motor 1 gain value	0–200%	90
↗ 11-22	Flux weakening curve for motor 2 gain value	0–200%	90
↗ 11-23	Flux weakening area speed response	0–150%	65
↗ 11-24	APR gain	0.00–40.00Hz (IM) / 0–100.00Hz (PM)	10.00

Pr.	Parameter Name	Setting Range	Default
↗ 11-25	Gain value for the APR feed forward	0–100	30
↗ 11-26	APR curve time	0.00–655.35 sec.	3.00
↗ 11-27	Maximum torque command	0–500%	100
↗ 11-28	Torque offset source	0: Disable 1: Analog signal input (Pr. 03-00) 2: Pr. 11-29 3: Controlled by external terminal (Pr. 11-30–11-32)	0
↗ 11-29	Torque offset setting	-100.0–100.0%	0.0
↗ 11-30	High torque compensation	-100.0–100.0%	30.0
↗ 11-31	Middle torque compensation	-100.0–100.0%	20.0
↗ 11-32	Low torque compensation	-100.0–100.0%	10.0
↗ 11-33	Torque command source	0 : Digital keypad 1 : RS-485 communication (Pr. 11-34) 2: Analog signal input (Pr. 03-00) 3: CANopen 5: Communication extension card	0
↗ 11-34	Torque command	-100.0–100.0% (Pr. 11-27 set value = 100 %)	0.0
↗ 11-35	Torque command filter time	0.000–1.000 sec.	0.000
11-36	Speed limit selection	0: Set by Pr. 11-37 (Forward speed limit) and Pr. 11-38 (Reverse speed limit) 1: Set by Pr. 11-37, Pr. 11-38 and Pr. 00-20 (Source of master frequency command) 2: Set by Pr. 00-20 (Source of master frequency command).	0
↗ 11-37	Forward speed limit (torque mode)	0–120%	10
↗ 11-38	Reverse speed limit (torque mode)	0–120%	10
11-39	Zero torque command mode selection	0: Torque mode 1: Speed mode	0
↗ 11-40	Point-to-point position control command source	0: External terminal 2: RS-485 3: CANopen 5: Communication card	0
↗ 11-42	System control flag	0000–FFFFh	0000h
↗ 11-43	Point- to-point position control maximum frequency	0.00–599.00Hz	10.00
↗ 11-44	Point-to-point position control acceleration time	0.00–655.35 sec.	1.00

Pr.	Parameter Name	Setting Range	Default
11-45	Point-to-point position control deceleration time	0.00–655.35 sec.	3.00
11-46	Torque output filter time	0.000–65.535 sec.	0.050

## 13 Application Parameters by Industry

Pr.	Parameter Name	Setting Range	Default
13-00	Industry Parameters combination	0: Disable 1: User-defined Parameter 2: Compressor (IM) 3: Fan 4: Pump 10: Air Handling Unit, AHU	0



## 14 Extension Card Parameter

Pr.	Parameter Name	Setting Range	Default
↗ 14-00	Extension card Input terminal selection (AI10)	0: Disable 1: Frequency command	0
↗ 14-01	Extension card Input terminal selection (AI11)	2: Torque command (torque limit under speed mode) 3: Torque compensation command	0
		4: PID target value 5: PID feedback signal 6: Thermistor (PTC / KTY-84) input value 7: Positive torque limit 8: Negative torque limit 9: Regenerative torque limit 10: Positive/ negative torque limit 11: PT100 thermistor input value 13: PID compensation amount	
↗ 14-08	Analog input filter time (AI10)	0.00–20.00 sec.	0.01
↗ 14-09	Analog input filter time (AI11)	0.00–20.00 sec.	0.01
↗ 14-10	Analog input 4–20mA signal loss selection (AI10)	0: Disable 1: Continue operation at the last frequency	0
↗ 14-11	Analog input 4–20mA signal loss selection (AI11)	2: Decelerate to 0Hz 3: Stop immediately and display ACE	0
↗ 14-12	Extension card output terminal selection (AO10)	0: Output frequency (Hz) 1: Frequency command (Hz)	0
↗ 14-13	Extension card output terminal selection (AO11)	2: Motor speed (Hz) 3: Output current (rms)	0
		4: Output voltage 5: DC BUS voltage 6: Power factor 7: Power 8: Torque 9: AVI 10: ACI 12: q-axis current (Iq) 13: q-axis feedback value (Iq) 14: d-axis current (Id) 15: d-axis feedback value (Id) 18: Torque command 19: PG2 frequency command 20: CANopen analog output 21: RS-485 analog output	

Pr.	Parameter Name	Setting Range	Default
		22: Communication card analog output 23: Constant voltage output 25: CANopen and RS-485 analog output	
↗	14-14 Analog output 1 gain output (AO10)	0.0–500.0%	100.0
↗	14-15 Analog output 1 gain output (AO11)	0.0–500.0%	100.0
↗	14-16 Analog output 1 in REV direction (AO10)	0: Absolute value of output voltage 1: Reverse output 0V; Forward output 0–10V 2: Reverse output 5~0V; Forward output 5–10V	0
↗	14-17 Analog output 1 in REV direction (AO11)		0
↗	14-18 Extension card input selection (AI10)	0: 0–10V (AVI10) 1: 0–20mA (ACI10) 2: 4–20mA (ACI10)	0
↗	14-19 Extension card input selection (AI11)	0: 0–10V (AVI11) 1: 0–20mA (ACI11) 2: 4–20mA (ACI11)	0
	14-20 AO10 DC output setting level	0.00–100.00 %	0.00
	14-21 AO11 DC output setting level	0.00–100.00 %	0.00
↗	14-22 AO10 filter output time	0.00–20.00 sec.	0.01
↗	14-23 AO11 filter output time	0.00–20.00 sec.	0.01
↗	14-36 AO10 output selection	0: 0–10V 1: 0–20mA 2: 4–20mA	0
↗	14-37 AO11 output selection		0

[The page intentionally left blank]

# Chapter 12 Description of Parameter Settings

## 12-1 Description of Parameter Settings

### 00 Drive Parameters

✎ You can set this parameter during operation.

**00-00** Identity Code of the AC Motor Drive

Default: ##

Settings Read Only

**00-01** Display AC Motor Drive Rated Current

Default: ##

Settings Read Only

Pr. 00-00 displays the identity code of the AC motor drive. Use the following specification table to check if Pr.00-01 setting is the rated current of the AC motor drive. Pr.00-01 corresponds to the identity code of the AC motor drive (Pr. 00-00).

The default is the rated current for normal load. Set Pr.00-16 to 1 to display the rated current for heavy load.

230V Series										
Frame	A				B			C		
kW	0.75	1.5	2.2	3.7	5.5	7.5	11	15	18.5	22
HP	1.0	2.0	3.0	5.0	7.5	10	15	20	25	30
Identity code	4	6	8	10	12	14	16	18	20	22
Rated current for heavy load (A)	4.8	7.1	10	16	24	31	47	62	71	86
Rated current for normal load (A)	5	8	11	17	25	33	49	65	75	90

Frame	D		E			F
kW	30	37	45	55	75	90
HP	40	50	60	75	100	125
Identity code	24	26	28	30	32	34
Rated current for heavy duty (A)	114	139	171	204	242	329
Rated current for normal duty (A)	120	146	180	215	255	346

460V Series													
Frame	A						B			C			
kW	0.75	1.5	2.2	3.7	4.0	5.5	7.5	11	15	18.5	22	30	
HP	1	2	3	5	5	7.5	10	15	20	25	30	40	
Identity code	5	7	9	11	93	13	15	17	19	21	23	25	
Rated current for heavy load (A)	2.9	3.8	5.7	8.1	9.5	11	17	23	30	36	43	57	
Rated current for normal load (A)	3.0	4.0	6.0	9.0	10.5	12	18	24	32	38	45	60	

Frame	D0		D		E		F		G		H			
kW	37	45	55	75	90	110	132	160	185	220	280	315	355	450
HP	50	60	75	100	125	150	175	215	250	300	375	425	475	600
Identity code	27	29	31	33	35	37	39	41	43	45	47	49	51	55
Rated current for heavy load (A)	69	86	105	143	171	209	247	295	352	437	523	585	649	816
Rated current for normal load (A)	73	91	110	150	180	220	260	310	370	460	550	616	683	866

575V Series							
Frame	A			B			
kW	1.5	2.2	3.7	5.5	7.5	11	15
HP	2	3	5	7.5	10	15	20
Identity code	505	506	507	508	509	510	511
Rated current for heavy load (A)	2.1	3	4.6	6.9	8.3	13	16.8
Rated current for normal load (A)	2.5	3.6	5.5	8.2	10	15.5	20

690V Series												
Frame	C				D		E				F	
kW	18.5	22	30	37	45	55	75	90	110	132	160	200
HP	25	30	40	50	60	75	100	125	150	175	215	270
Identity code	612	613	614	615	616	617	618	619	620	621	622	686
Rated current for heavy load (A)	14	20	24	30	36	45	54	67	86	104	125	150
Rated current for normal load (A)	20	24	30	36	45	54	67	86	104	125	150	180

Frame	G		H			
kW	250	315	400	450	560	630
HP	335	425	530	600	745	840
Identity code	687	626	628	629	631	632
Rated current for heavy load (A)	180	220	290	310	420	675
Rated current for normal load (A)	220	290	350	385	465	675



Parameter Reset

Default: 0

- Settings 0: No Function
- 1: Write protection for parameters
  - 5: Reset kWh display to 0
  - 6: Reset PLC (including CANopen Master Index)
  - 7: Reset CANopen Index (Slave)
  - 9: Reset all parameters to defaults with base frequency at 50 Hz
  - 10: Reset all parameters to defaults with base frequency at 60Hz

- When set to 1, all parameters are read only except Pr. 00-02, Pr. 00-07 and Pr. 00-08. Set Pr. 00-02 to 0 before changing other parameter settings.
- When set to 9 or 10, reset all parameters to defaults. If there is a password set in Pr. 00-08, enter the password set in Pr. 00-07 to reset to default.
- When set to 5, kWh displayed value can be reset to 0 even when the drive is operating. Pr. 05-26, Pr. 05-27, Pr. 05-28, Pr. 05-29, and Pr. 05-30 are reset to 0.
- When set to 6, clear internal PLC program (includes the related settings of PLC internal CANopen master)
- When set to 7, reset the related settings of CANopen slave.
- When set to 6, 7, 9, 10, reboot the motor drive after setting.

## 00-03 Start-up Display Selection

Default: 0

- Settings
- 0: F (Frequency command)
  - 1: H (Output frequency)
  - 2: U (User defined)
  - 3: A (Output current)

 This parameter determines the start-up display page. This is the user defined choice display according to the setting in Pr.00-04.

## 00-04 Content of Multi-function Display (User-defined)

Default: 3

- Settings
- 0: Display output current (A) (Unit: Amp)
  - 1: Display counter value (c) (Unit: CNT)
  - 2: Display actual output frequency (H.) (Unit: Hz)
  - 3: Display DC BUS voltage (v) (Unit: V<sub>DC</sub>)
  - 4: Display output voltage (E) (Unit: V<sub>AC</sub>)
  - 5: Display output power angle (n) (Unit: deg)
  - 6: Display output power in kW (P) (Unit: kW)
  - 7: Display actual motor speed rpm (r) (Unit: rpm)
  - 8: Display estimate output torque % (t) (Unit: %)
  - 9: Display PG feedback (G) (refer to Pr. 10-00 and Pr. 10-01) (Unit: PLS)
  - 10: Display PID feedback (b) (Unit: %)
  - 11: Display AVI in % (1.) (Unit: %)
  - 12: Display ACI in % (2.) (Unit: %)
  - 13: Display AUI in % (3.) (Unit: %)
  - 14: Display the temperature of IGBT (i.) (Unit: °C)
  - 15: Display the temperature of capacitance (c.) (Unit: °C)
  - 16: The status of digital input (ON/OFF), refer to Pr. 02-12 (i)
  - 17: The status of digital output (ON/OFF), refer to Pr. 02-18 (o)
  - 18: Multi-step speed (S)
  - 19: The corresponding CPU pin status of digital input (d)
  - 20: The corresponding CPU pin status of digital output (0.)
  - 21: Actual motor position (PG1 of PG card) (P.) The maximum value is 32bits display
  - 22: Pulse input frequency (PG2 of PG card) (S.)
  - 23: Pulse input position (PG2 of PG card) (q.) The maximum value is 32bits display
  - 24: Position command tracing error (E.)
  - 25: Overload counting (0.00–100.00%) (o.) (Unit: %)
  - 26: Ground fault GFF (G.) (Unit: %)
  - 27: DC BUS voltage ripple (r.) (Unit: V<sub>DC</sub>)
  - 28: Display PLC register D1043 data (C)

- 29: Display PM pole section (EMC-PG01U application) (4.)
- 30 : Display output of user defined (U)
- 31 : Display Pr. 00-05 user Gain (K)
- 32: Number of actual motor revolution during operation (PG card plug in and Z phase signal input) (Z.)
- 33: Motor actual position during operation (when PG card is connected)(q)
- 34: Operation speed of fan (F.) (Unit: %)
- 35: Control Mode display: 0= Speed control mode (SPD), 1= torque control mode (TQR) (t.)
- 36: Present operating carrier frequency of drive (Hz) (J.)
- 38: Display drive status (6.) (Refer to Note 7)
- 39: Display estimated output torque, positive and negative, using Nt-m as unit (t=0.0: positive torque; -0.0: negative torque) (C.)
- 40: Torque command (L.) (Unit: %)
- 41: kWh display (J) (Unit: kWh)
- 42: PID reference (h.) (Unit: %)
- 43: PID offset (o.) (Unit: %)
- 44: PID output frequency (b.) (Unit: Hz)
- 45: Hardware ID
- 49: Motor temperature (PTC, PT100, KTY84-130)
- 51: PMSVC torque offset
- 52: AI10%
- 53: AI11%

 Explanation 1

- When Pr. 10-01 is set to 1000 and Pr. 10-02 is set to 1, 2, the displayed range for PG feedback is between 0–4000.
- When Pr. 10-01 is set to 1000 and Pr. 10-02 is set to 3, 4, 5, the displayed range for PG feedback is between 0–1000.
- Home position: If it has Z phase, Z phase will be regarded as home position. Otherwise, home position will be the encoder start up position.

 Explanation 2

It can also display negative values when setting analog input bias (Pr. 03-03–03-10).

Example: Assume that AVI input voltage is 0 V, Pr. 03-03 is 10.0% and Pr. 03-07 is 4 (Bias serves as the center).

 Explanation 3

Example: If REV, MI1 and MI6 are ON, the following table shows the status of the terminals.

Normally opened contact (N.O.), 0: OFF, 1: ON

Terminal	MI15	MI14	MI13	MI12	MI11	MI10	MI8	MI7	MI6	MI5	MI4	MI3	MI2	MI1	REV	FWD
Status	0	0	0	0	0	0	0	0	1	0	0	0	0	1	1	0

 **NOTE** MI10–MI15 are the terminals for extension cards (Pr. 02-26–02-31).

- The value is 0000 0000 1000 0110 in binary and 0086H in HEX. When Pr. 00-04 is set to 16 or 19, the u page on the keypad displays 0086H.

- The setting value 16 is ON / OFF status of digital input according to Pr. 02-12 setting, and the setting value 19 is the corresponding CPU pin ON / OFF status of the digital input.
- The FWD / REV action and MI1 (which is set as three-wire) are not affected by Pr. 02-12.
- You can set 16 to monitor the digital input status, and then set 19 to check if the circuit is normal.

#### Explanation 4

Assume that RY1: Pr. 02-13 is set to 9 (Drive is ready). After the AC motor drive powers on, if there is no other abnormal status, the contact is ON. The display status is shown below.

Normally opened contact (N.O.)

Terminal	MO20	MO19	MO18	MO17	MO16	MO15	MO14	MO13	MO12	MO11	MO10	MO2	MO1	Reserved	RY2	RY1
Status	0	0	0	0	0	0	0	0	0	0	0	0	0	0	0	1

- If Pr. 00-04 is set to 17 or 20, it displays in hexadecimal "0001h" with LED u page is ON in the keypad.
- The setting value 17 is ON / OFF status of digital output according to Pr. 02-18 setting, and the setting value 19 is the corresponding CPU pin ON / OFF status of the digital output.
- You can set 17 to monitor the digital output status, and then set 20 to check if the circuit is normal.

#### Explanation 5

Setting value 8: 100% means the motor rated torque.

Motor rated torque = (Motor rated power x 60 / 2π) / Motor rated rotating speed

#### Explanation 6

Setting value 25: when displayed value reaches 100.00%, the drive shows "oL" as an overload warning.

#### Explanation 7

Setting value 38

bit0: The drive is running forward.

bit1: The drive is running backward.

bit2: The drive is ready.

bit3: Errors occurred on the drive.

bit4: The drive is running.

bit5: Warnings occurred on the drive.

#### **00-05** Coefficient Gain in Actual Output Frequency

Default: 0

Settings 0.00–160.00

 This parameter is to set coefficient gain in actual output frequency. Set Pr. 00-04= 31 to display the calculation result on the screen (calculation = output frequency \* Pr. 00-05).

#### **00-06** Software Version

Default: Read only

Settings Read only



➤ **00-07** Parameter Protection Password Input

Default: 0

Settings 0–65535

Display 0–4 (the number of password attempts allowed)

- 📖 This parameter allows you to enter your password (which is set in Pr. 00-08) to unlock the parameter protection and to make changes to the parameter.
- 📖 To avoid problems in the future, be sure to write down the password after you set this parameter.
- 📖 Pr. 00-07 and Pr. 00-08 are used to prevent personnel from setting other parameters by accident.
- 📖 If you forget the password, clear the password setting by input 9999 and press the ENTER key, then enter 9999 again and press ENTER within 10 seconds. After decoding, all the settings return to default.
- 📖 When setting is under password protection, all the parameters read 0, except Pr. 00-08.

➤ **00-08** Parameter Protection Password Setting

Default: 0

Settings 0–65535

0: No password protection or password entered correctly (Pr. 00-07)

1: Password has been set

- 📖 This parameter is for setting the password protection. Password can be set directly the first time. After you set the password, the value of Pr.00-08 is 1, which means password protection is activated. At this time, if you want to change any of the parameter settings, you must enter the correct password in Pr.00-07 to deactivate the password temporarily, and this would make Pr.00-08 become 0. After you finish setting the parameters, reboot the motor drive and the password is activated again.
- 📖 Entering the correct password in Pr.00-07 only temporarily deactivates the password. To permanently deactivate password protection, set Pr.00-08 to 0 manually. Otherwise, password protection is always reactivated after you reboot the motor drive.
- 📖 The keypad copy function works normally only when the password protection is deactivated (temporarily or permanently), and password set in Pr. 00-08 cannot be copied to the keypad. So when copying parameters from the keypad to the motor drive, set the password manually again in the motor drive to activate password protection.

Password Decode Flow Chart

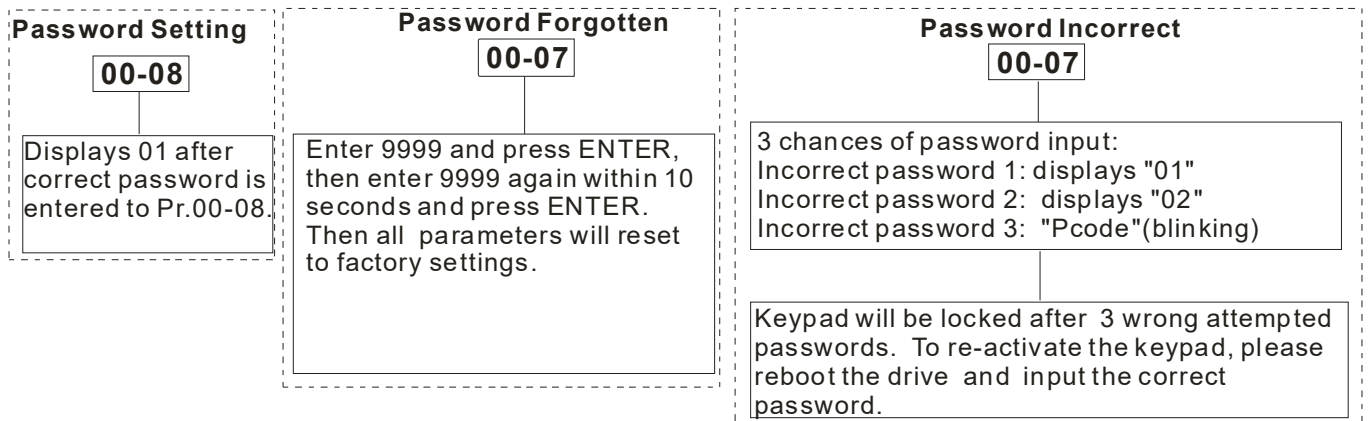

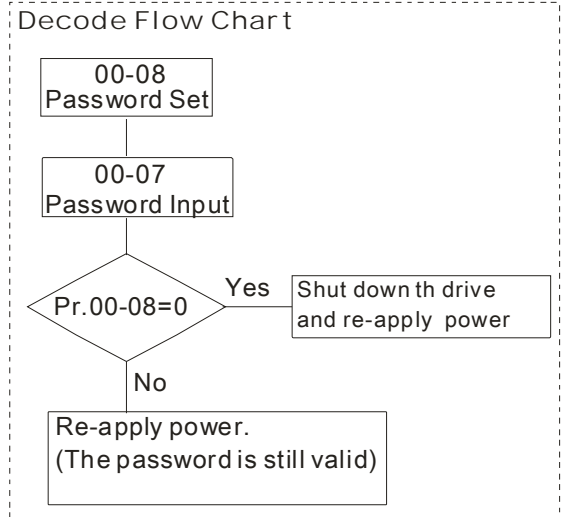

## 00-10 Control Mode

Default: 0

- Settings
- 0: Speed mode
  - 1: Point-to-Point position control mode
  - 2: Torque mode
  - 3: Homing mode

Determines the control mode of the AC motor drive.

## 00-11 Speed Control Mode

Default: 0

- Settings
- 0: IMVF (IM V/F control)
  - 1: IMVFPG (IM V/F control+ Encoder)
  - 2: IM/PM SVC (IM/PM space vector control)
  - 3: IMFOCPG (IM FOC + Encoder)
  - 4: PMFOCPG (PM FOC + Encoder)
  - 5: IMFOC Sensorless (IM FOC sensorless)
  - 6: PM Sensorless (PM FOC sensorless)
  - 7: IPM Sensorless (Interior PM FOC sensorless)

Determines the control method of the AC motor drive:

- 0: IM V/F control, you can set the proportion of V/F as required and control multiple motors simultaneously.
- 1: IM V/F control + Encoder, you can use optional PG card with encoder for the closed-loop speed control.
- 2: IM/PM space vector control, get the optimal control by auto-tuning the motor parameters.
- 3: IM FOC + encoder, not only can increase torque, but also can increase the accuracy of the speed control (1:1000).
- 4: PM FOC + Encoder, not only can increase torque, but also can increase the accuracy of the speed control (1:1000).
- 5: IM FOC sensorless, IM field oriented sensorless vector control
- 6: PM FOC sensorless, PM field oriented sensorless vector control
- 7: Interior PM FOC sensorless, Interior PM field oriented sensorless vector control

- There are more detailed explanation of motor adjustment procedure in section 12-2
- When Pr. 00-10=0, and you set Pr. 00-11 to 0, the V/F control diagram is as follows.

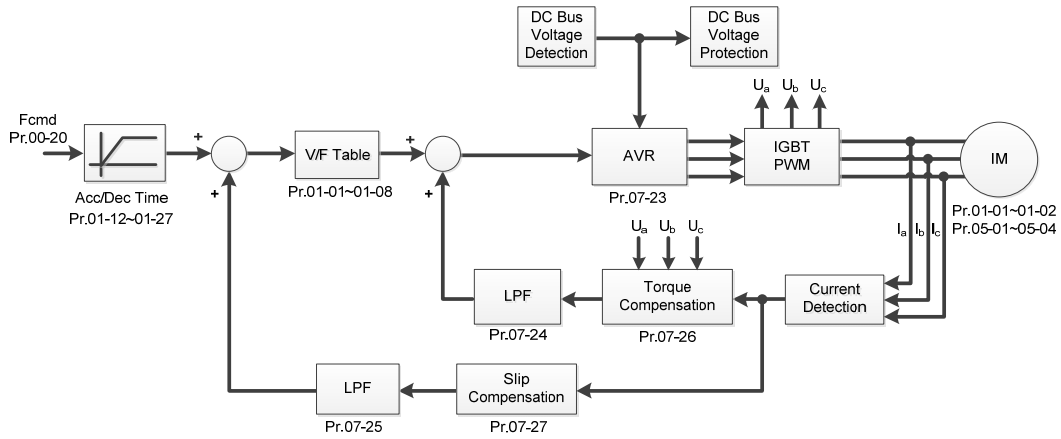

- When Pr. 00-10=0, and you set Pr. 00-11 to 1, the V/F control + encoder diagram is as follows.

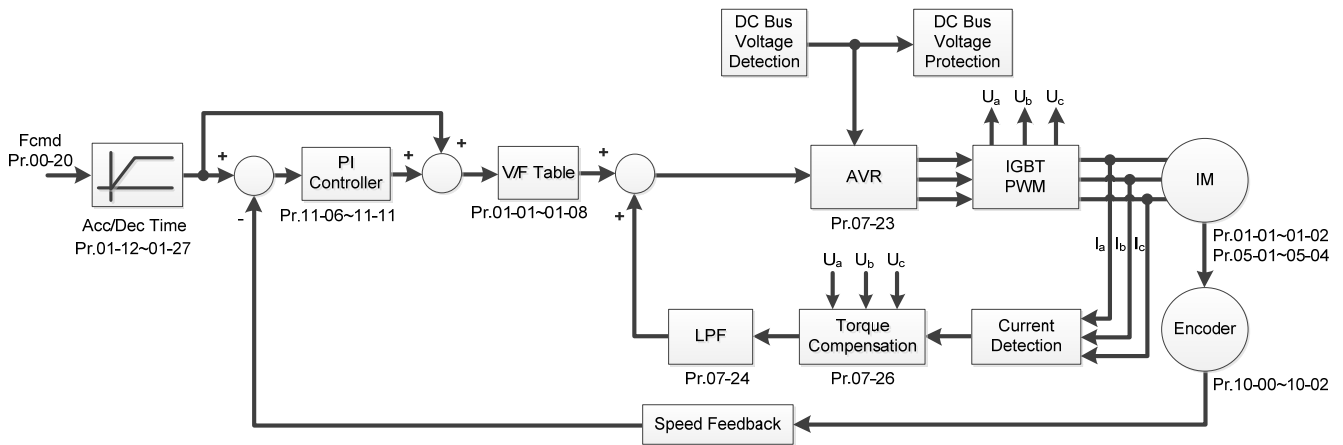

- When Pr. 00-10=0, and you set Pr. 00-11 to 2, the space vector control diagram is as follows:  
IM Space Vector Control (IMSV):

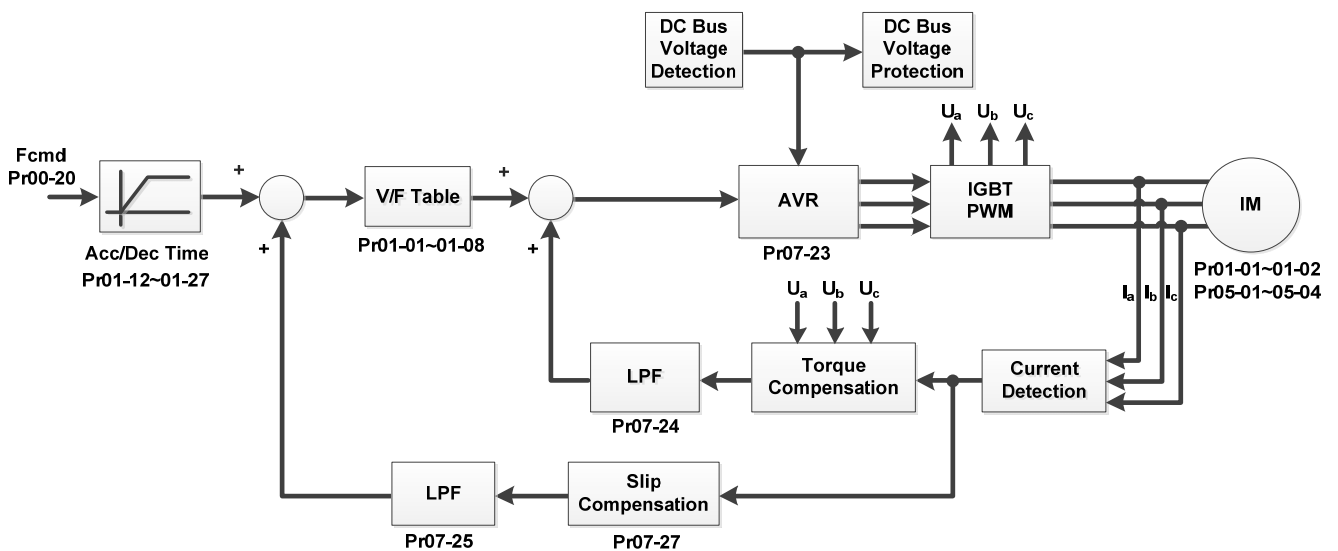

PM Space Vector Control (PMSVC):

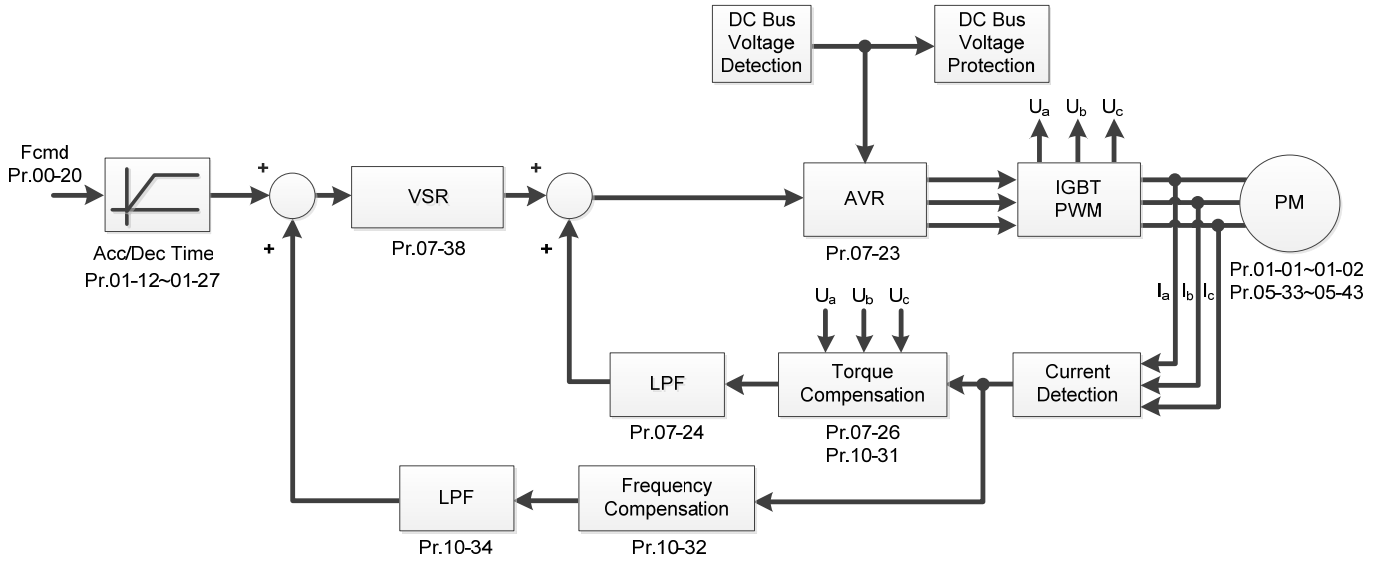

When Pr. 00-10=0, and you set Pr. 00-11 to 3, the IM FOCPG control diagram is as follows:

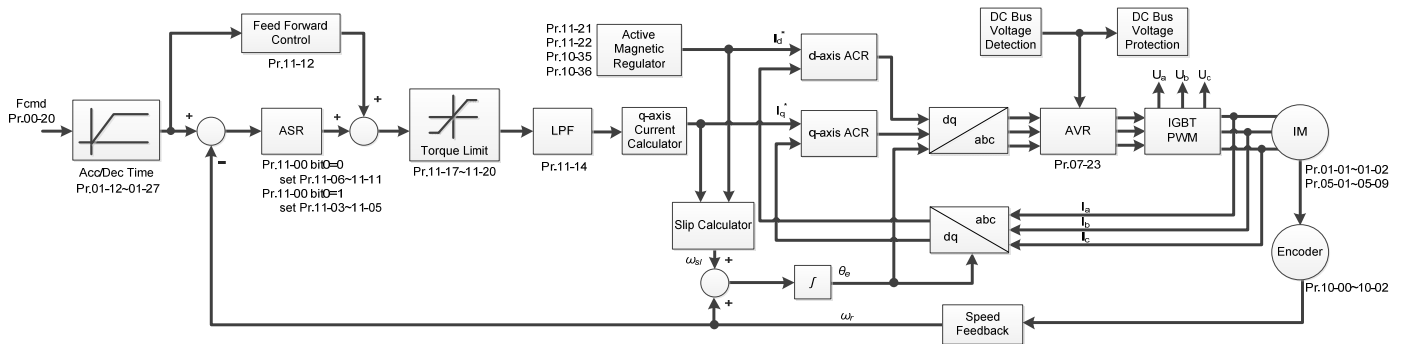

When Pr. 00-10=0, and you set Pr. 00-11 to 4, the PM FOCPG control diagram is as follows:

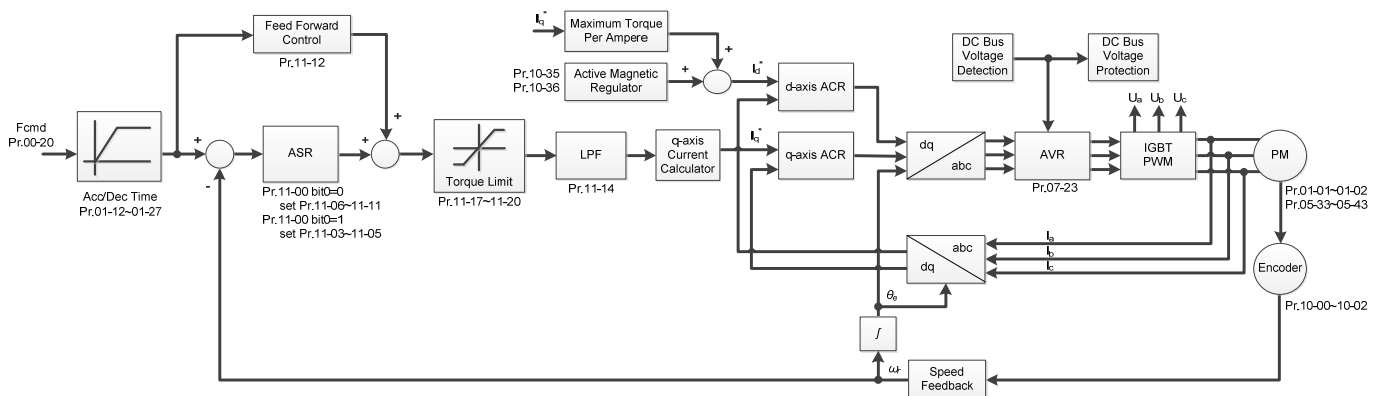

When Pr. 00-10=0, and you set Pr. 00-11 to 5, IMFOC Sensorless control diagram is as follows:

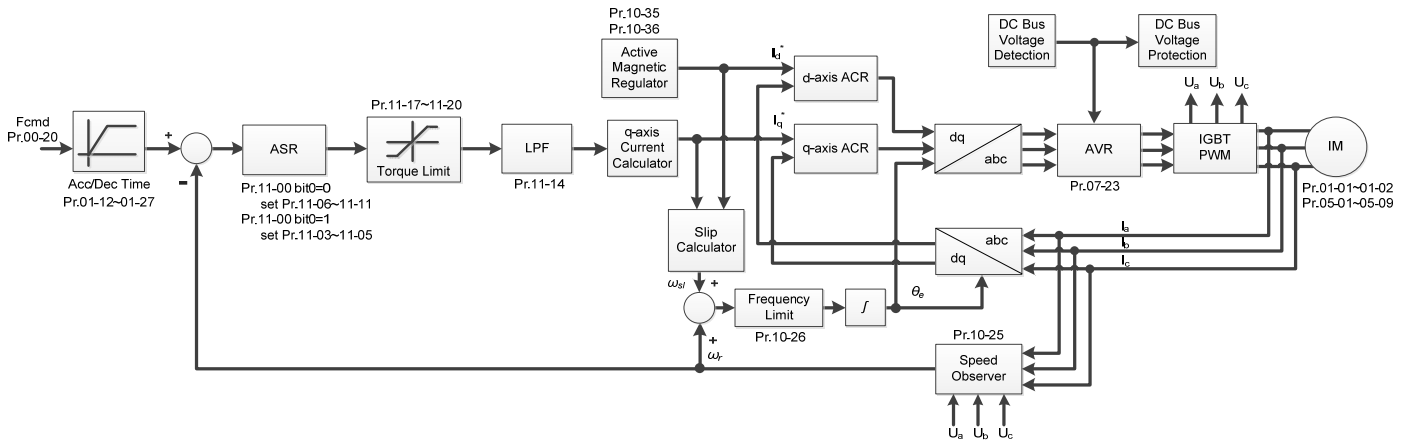

When Pr. 00-10=0, and you set Pr. 00-11 to 6, PM FOC Sensorless control diagram is as follows:

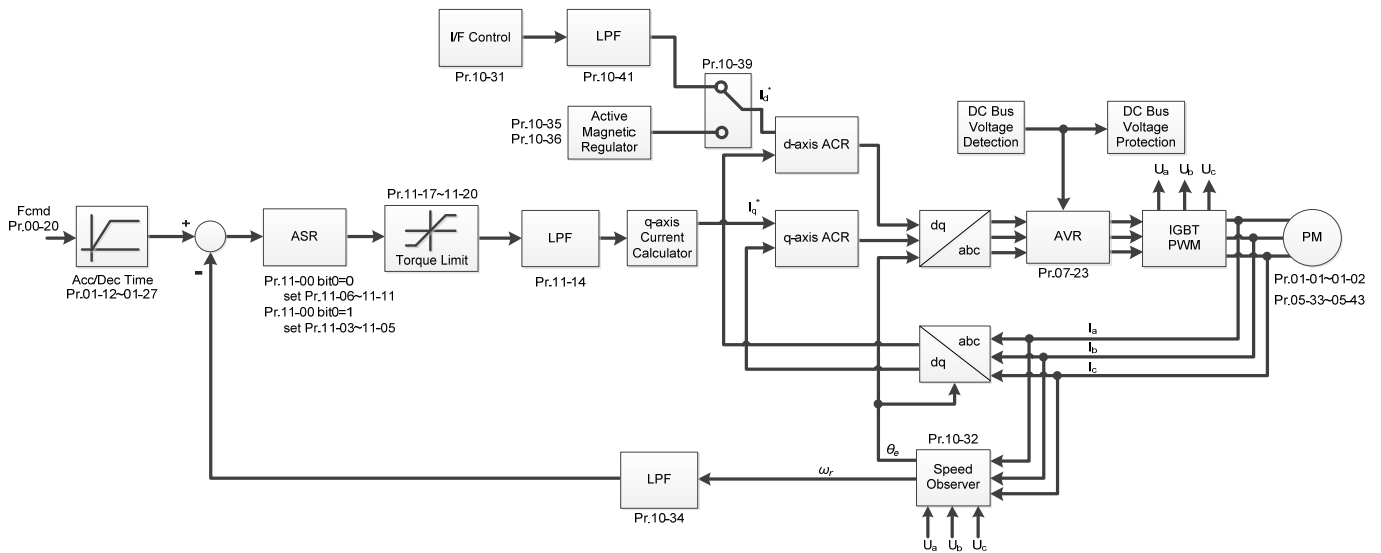

When Pr. 00-10=0, and you set Pr. 00-11 to 7, IPM FOC sensorless DC control diagram is as follows:

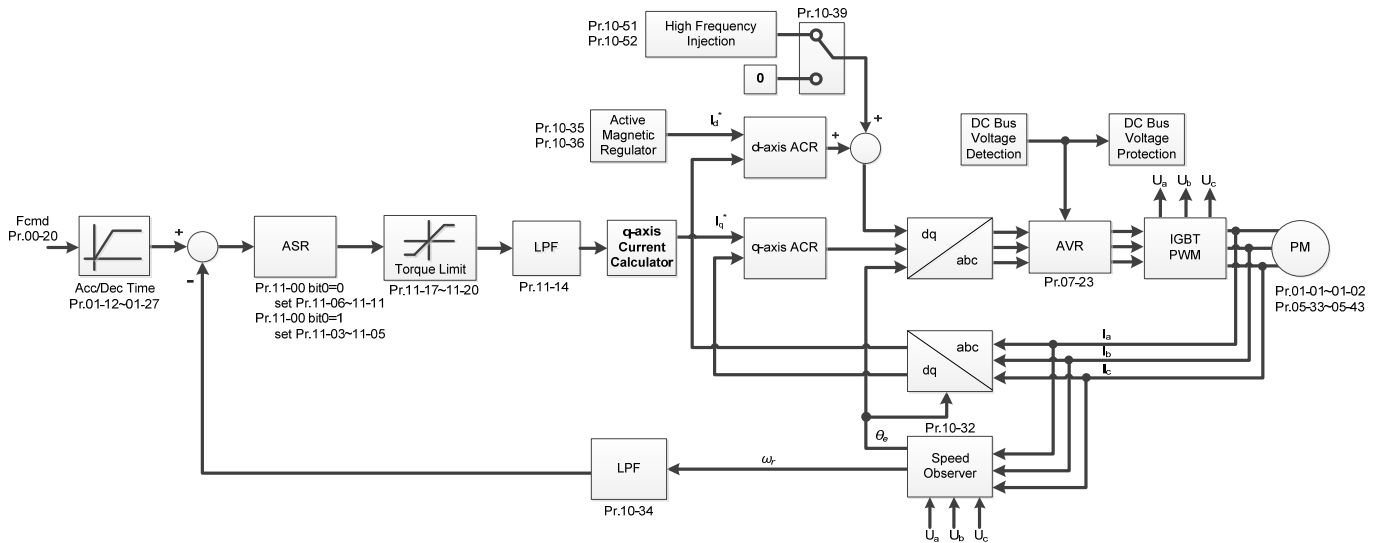

**00-12** Point-to-Point Position Control

Default: 0

Settings: 0: Relative position  
1: Absolute position

Pr. 00-12 = 0 is incremental type P2P; Pr. 00-12 = 1 is absolute type P2P

Setting=0

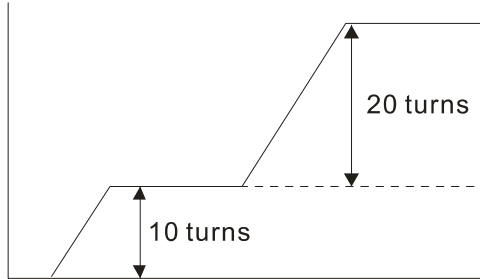

Setting=1

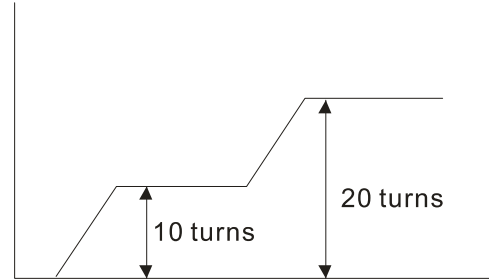

**00-13** Control of Torque Mode

Default: 0

Settings 0: IM TQCPG (IM Torque control + Encoder)  
1: PM TQCPG (PM Torque control + Encoder)  
2: IM TQC Sensorless (IM Sensorless torque control)

Pr. 00-13=0, IM TQCPG control diagram is as follows:

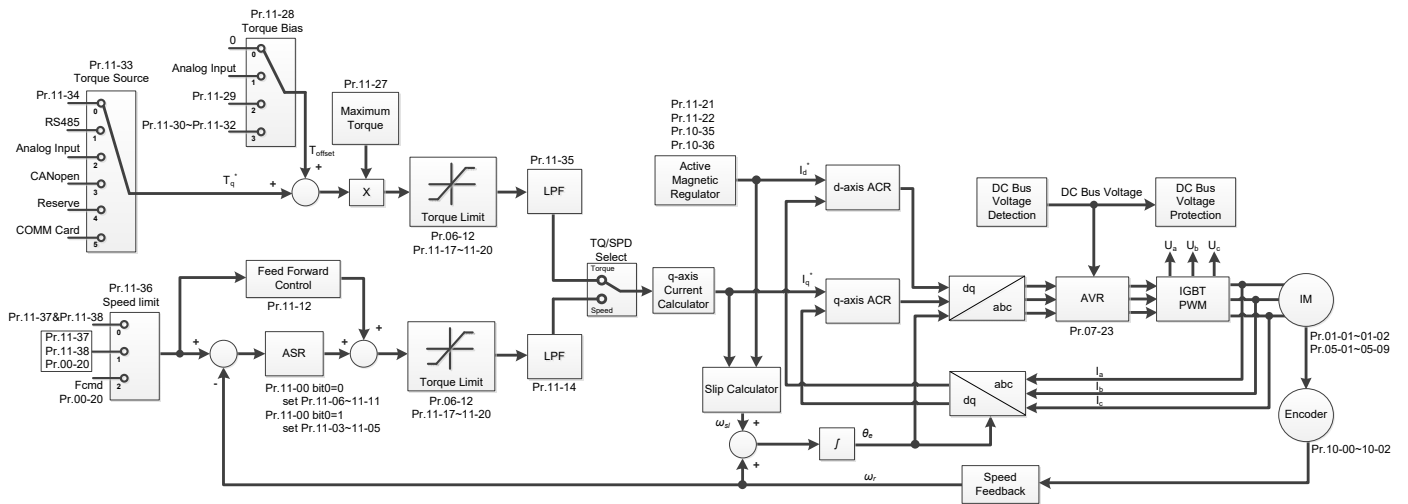

Pr. 00-13=1, PM TQCPG control diagram is as follows:

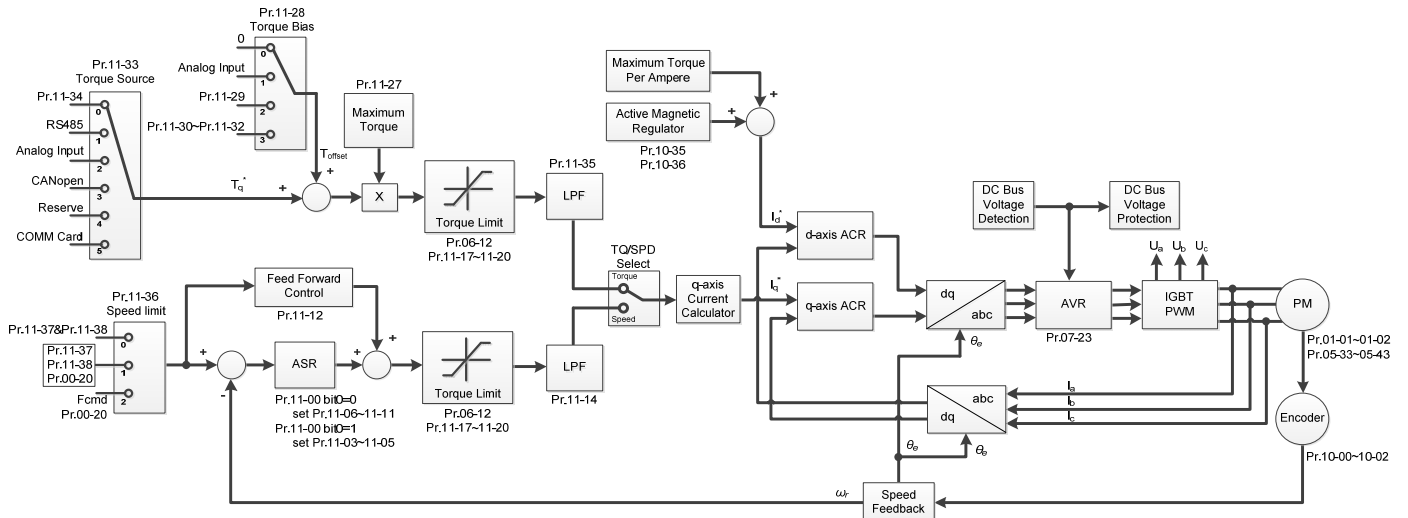

Pr. 00-13=2, IM TQC Sensorless control diagram is as follows:

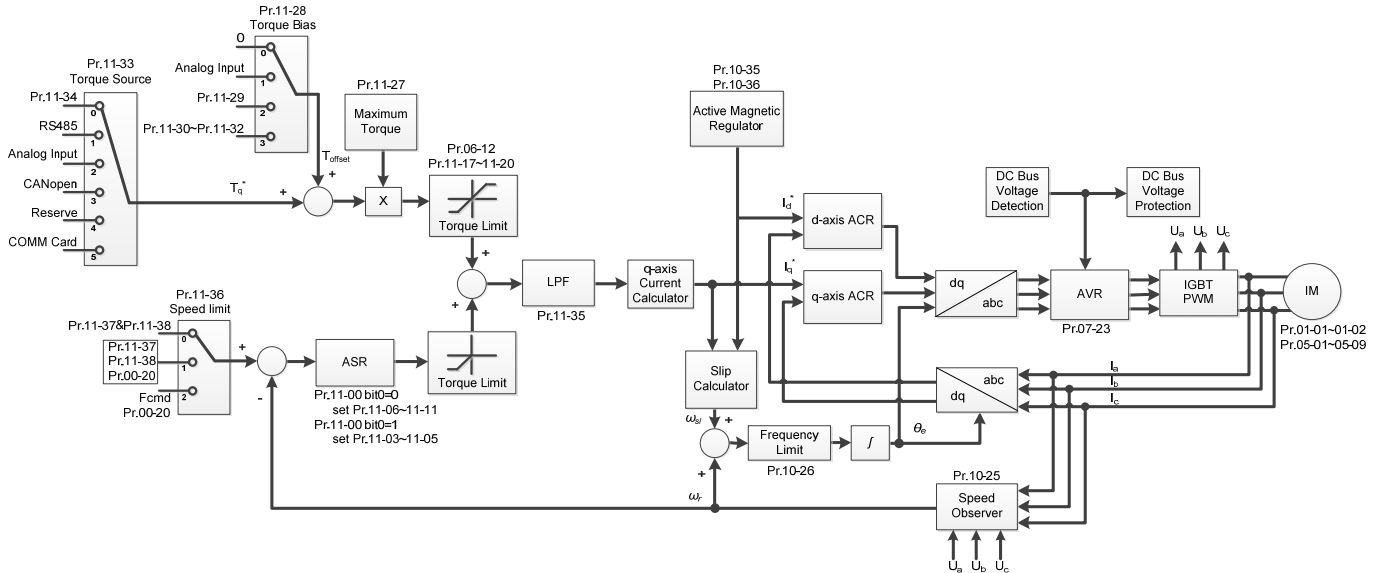

**00-16** Load Selection Default: 0

Settings 0: Normal load  
1: Heavy load

- Normal load: over-load ability is 160% rated output current in 3 seconds (120% rated output current in 1 minute). Refer to Pr. 00-17 for the setting of carrier wave. Refer to Chapter 9 “Specifications” or Pr. 00-01 for the rated current.
- Heavy load: over-load ability is 180% rated output current in 3 seconds. (150% rated output current in 1 minute). Refer to Pr. 00-17 for the setting of carrier wave. Refer to Chapter 9 “Specifications” or Pr. 00-01 for the rated current.
- Pr.00-01 varies with the setting value for Pr.00-16. The default value and maximum for Pr.06-03 and Pr.06-04 also vary with the setting value of Pr.00-16.
- In Normal load, the default setting of Pr. 06-03, Pr. 06-04 is 120%, and the maximum is 160%. However, if DC voltage is higher than 700 V<sub>DC</sub> (460V series) or 350 V<sub>DC</sub> (230V series), then the maximum is 145%
- In Heavy load, the default setting of Pr. 06-03, Pr. 06-04 is 150%, and the maximum is 180%. However, if DC voltage is higher than 700 V<sub>DC</sub> (460V series) or 350 V<sub>DC</sub> (230V series), then the maximum is 165%

**00-17** Carrier Frequency Default: Table below

Settings 2–15kHz

This parameter determines the PWM carrier frequency for the AC motor drive.

Power/ Control mode	230V Series [Normal Load]							
	VF, VFPG, SVC, IMFOCPG, IMTQCPG		PMFOCPG, PMTQCPG		PMFOC, IPMFOC		IMFOC, IMTQC	
	Settings	Default	Settings	Default	Settings	Default	Settings	Default
1–15HP [0.75–11kW]	2–15kHz	8kHz	4–15kHz	8kHz	4–10kHz	8kHz	4–14kHz	8kHz
20–50HP [15–37kW]	2–10kHz	6kHz	4–10kHz	6kHz	4–10kHz	6kHz	4–10kHz	6kHz
60–125HP [45–90kW]	2–9kHz	4kHz	4–9kHz	4kHz	4–9kHz	4kHz	4–9kHz	4kHz

230V Series [Heavy Load]								
1-15HP [0.75-11kW]	2-15kHz	2kHz	4-15kHz	4kHz	4-10kHz	4kHz	4-14kHz	4kHz
20-50HP [15-37kW]	2-10kHz	2kHz	4-10kHz	4kHz	4-10kHz	4kHz	4-10kHz	4kHz
60-125HP [45-90kW]	2-9kHz	2kHz	4-9kHz	4kHz	4-9kHz	4kHz	4-9kHz	4kHz

460V Series [Normal Load]								
Power/ Control mode	VF, VFPG, SVC, IMFOCPG, IMTQCPG		PMFOCPG, PMTQCPG		PMFOC, IPMFOC		IMFOC, IMTQC	
	Settings	Default	Settings	Default	Settings	Default	Settings	Default
1-15HP [0.75-11kW]	2-15kHz	8kHz	4-15kHz	8kHz	4-10kHz	8kHz	4-14kHz	8kHz
20-50HP [15-37kW]	2-10kHz	6kHz	4-10kHz	6kHz	4-10kHz	6kHz	4-10kHz	6kHz
60-125HP [45-90kW]	2-9kHz	4kHz	4-9kHz	4kHz	4-9kHz	4kHz	4-9kHz	4kHz

460V Series [Heavy Load]								
1-15HP [0.75-11kW]	2-15kHz	2kHz	4-15kHz	4kHz	4-10kHz	4kHz	4-14kHz	4kHz
20-50HP [15-37kW]	2-10kHz	2kHz	4-10kHz	4kHz	4-10kHz	4kHz	4-10kHz	4kHz
60-125HP [45-90kW]	2-9kHz	2kHz	4-9kHz	4kHz	4-9kHz	4kHz	4-9kHz	4kHz

Power/ Control mode	575V Series [Light/ Normal/ Heavy Load]		690V Series [Light/ Normal/ Heavy Load]	
	VF, VFPG, SVC			
	Settings	Default	Settings	Default
1-15HP [0.75-11kW]	2-15kHz	6kHz	-	-
20-600HP [15-450kW]	-	-	2-9kHz	4kHz
850HP [630kW]	-	-	2-9kHz	3kHz

Carrier Frequency	Acoustic Noise	Electromagnetic Noise or Leakage Current	Heat Dissipation	Current Wave
2kHz	Significant ↑ Minimal	Minimal ↑ Significant	Minimal ↑ Significant	
8kHz				
15kHz				

From the table, you see that the PWM carrier frequency has significant influences on the electromagnetic noise, the AC motor drive heat dissipation, and the motor acoustic noise. Therefore, if the surrounding noise is greater than the motor noise, lower the carrier frequency is good to reduce the temperature rise. Although it is quiet operation in the higher carrier frequency, the entire wiring and interference resistance should be considerate.

When the carrier frequency is higher than the factory setting, it needs to protect by decreasing the carrier frequency. See Pr. 06-55 for the related setting and details.



**00-19** PLC Command Mask

Default: Read Only

- Settings
- bit0: Control command by PLC force control
  - bit1: Frequency command by PLC force control
  - bit2: Position command by PLC force control
  - bit3: Torque command by PLC force control

 Determines if frequency command or control command is locked by PLC

**00-20** Master Frequency Command (AUTO) Source / Source Selection of the PID Target

Default: 0

- Settings
- 0: Digital keypad
  - 1: RS-485 communication
  - 2: External analog input (Pr. 03-00)
  - 3: External UP / DOWN terminal (multi-function input terminal)
  - 4: Pulse input without direction command (Pr. 10-16 without direction), use with PG card
  - 5: Pulse input with direction command (Pr. 10-16), use with PG card
  - 6: CANopen communication card
  - 8: Communication card (does not include CANopen card)

 Set the source of the master frequency in AUTO mode.

 Pr. 00-20 and Pr. 00-21 are for the settings of frequency source and operation source in AUTO mode. Pr. 00-30 and Pr. 00-31 are for the settings of frequency source and operation source in HAND mode. You can switch the AUTO / HAND mode with the keypad KPC-CC01 (optional) or the multi-function input terminal (MI) to set the master frequency source.

 The default for the frequency source or operation source is for AUTO mode. It returns to AUTO mode whenever cycle the power. If you use a multi-function input terminal to switch between AUTO and HAND mode, the highest priority is the multi-function input terminal. When the external terminal is OFF, the drive does not accept any operation signal and cannot execute JOG.

 When Pr. 00-20=4, the pulse input without direction command has included PG and MI8 input.

**00-21** Operation Command (AUTO) Source

Default: 0

- Settings
- 0: Digital keypad
  - 1: External terminals. Keypad STOP disabled.
  - 2: RS-485 communication. Keypad STOP disabled.
  - 3: CANopen communication card
  - 5: Communication card (does not include CANopen card)

 Set the source of the operation frequency in AUTO mode.

 When you control the operation command by the keypad KPC-CC01, keys RUN, STOP and JOG (F1) are valid.

 **00-22** Stop Method

Default: 0

- Settings
- 0: Ramp to stop
  - 1: Coast to stop

 Determines how the motor is stopped when the AC motor drive receives the STOP command.

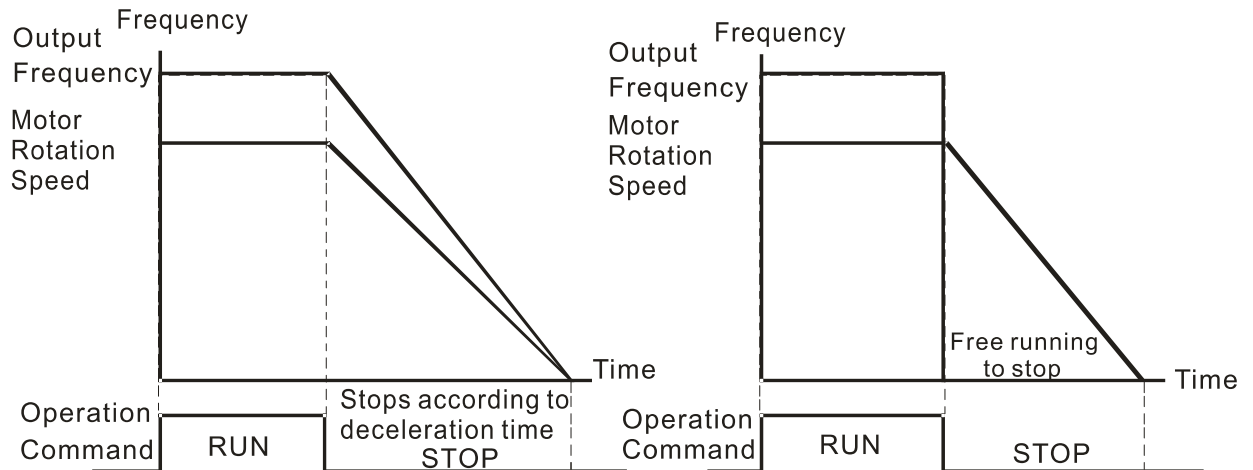

Ramp to Stop and Coast to Stop

1. **Ramp to stop:** the AC motor drive decelerates to 0 or the minimum output frequency (Pr. 01-07) according to the set deceleration time, and then to stop.
2. **Coast to stop:** the AC motor drive stops output immediately, and the motor coasts to stop according to the load inertia.
  - Use “ramp to stop” for the safety of personnel, or to prevent material from being wasted in applications where the motor must stop immediately after the drive stops. You must set the deceleration time accordingly.
  - If idling is allowed, or the load inertia is large, use “coast to stop”. For example, blowers, punching machines and pumps

#### **00-23** Control of Motor Direction

Default: 0

Settings 0: Enable forward/ reverse  
1: Disable reverse  
2: Disable forward

 Enable the AC motor drives to run in the forward / reverse direction. You can use it to prevent a motor from running in a direction that would cause injury or damage the equipment.

#### **00-24** Digital Keypad Frequency Command Memory

Default: Read Only

Settings Read only

 If the keypad is the frequency command source, when Lv or Fault occurs, the parameter stores the current frequency command.

#### **00-25** User-Defined Characteristics

Default: 0

Settings bit0–3: user-defined decimal places  
0000b: no decimal place  
0001b: one decimal place  
0010b: two decimal places  
0011b: three decimal places

bit 4–15: user-defined unit

- 000xh: Hz
- 001xh: rpm
- 002xh: %
- 003xh: kg
- 004xh: m/s
- 005xh: kW
- 006xh: HP
- 007xh: ppm
- 008xh: 1/m
- 009xh: kg/s
- 00Axh: kg/m
- 00Bxh: kg/h
- 00Cxh: lb/s
- 00Dxh: lb/m
- 00Exh: lb/h
- 00Fhx: ft/s
- 010xh: ft/m
- 011xh: m
- 012xh: ft
- 013xh: degC
- 014xh: degF
- 015xh: mbar
- 016xh: bar
- 017xh: Pa
- 018xh: kPa
- 019xh: mWG
- 01Axh: inWG
- 01Bxh: ftWG
- 01Cxh: psi
- 01Dxh: atm
- 01Exh: L/s
- 01Fhx: L/m
- 020xh: L/h
- 021xh: m<sup>3</sup>/s
- 022xh: m<sup>3</sup>/h
- 023xh: GPM
- 024xh: CFM
- xxxxh: Hz

- 
- 📖 bit 0–3: the control frequency F page, user-defined unit (Pr.00-04 = d10, PID feedback value) and the number of decimal places (Pr.00-26) which supports up to three decimal places.
  - 📖 bit 4–15: the control frequency F page, user-defined unit (Pr.00-04 = d10, PID feedback value) and the displayed units for Pr.00-26.

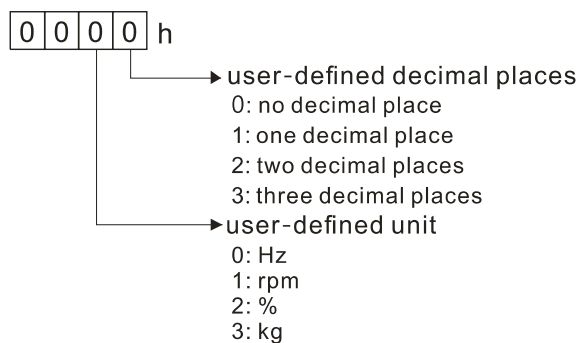

**00-26** Maximum User-Defined Value

Default: 0

- Settings 0: Disable
- 0–65535 (when Pr. 00-25 set to no decimal place)
  - 0.0–6553.5 (when Pr. 00-25 set to 1 decimal place)
  - 0.00–655.35 (when Pr. 00-25 set to 2 decimal places)
  - 0.000–65.535 (when Pr. 00-25 set to 3 decimal places)

 When Pr. 00-26 is NOT set to 0, the user-defined value is enabled. After selecting the displayed unit and number of decimal points with Pr.00-25, the setting value of Pr.00-26 corresponds to Pr.01-00 (Maximum motor operating frequency), and then the motor operation frequency has a linear relationship with the displayed value on the digital keypad.

Example:

When the frequency set in Pr. 01-00 = 60.00Hz, the maximum user-defined value for Pr. 00-26 is 100.0%. This also means Pr. 00-25 is set at 0021h to select % as the unit.



 **NOTE**

The drive display is controlled by the Pr. 00-25 setting when Pr. 00-25 is properly set and Pr.00-26 is not 0.

**00-27** User-Defined Value

Default: Read only

Settings Read only

-  Pr. 00-27 displays the user-defined value when Pr. 00-26 is not set to 0.
-  The user-defined function is valid only when Pr. 00-20 (frequency source) is set to digital keypad or RS-485 communication.

**00-29** LOCAL / REMOTE Mode

Default: 0

- Settings 0: Standard HOA function
- 1: When switching between local and remote, the drive stops
  - 2: When switching between local and remote, the drive runs with REMOTE settings for frequency and operation status
  - 3: When switching between local and remote, the drive runs with LOCAL settings for frequency and operation status
  - 4: When switching between local and remote, the drive runs with LOCAL setting when switched to Local and runs with REMOTE settings when switched to Remote for frequency and operation status.

 The default of Pr. 00-29 is 0 (standard Hand-Off-Auto function). Set the AUTO frequency and operation source with Pr.00-20 and Pr.00-21. Set the HAND frequency and operation source with Pr.00-30 and Pr.00-31. Select or switch AUTO / HAND mode by using the digital keypad (KPC-CC01) or setting the multi-function input terminal MI = 41, 42.

 When you set the external terminal (MI) to 41 and 42 (AUTO / HAND mode), Pr.00-29 = 1,2,3,4 are disabled. The external terminal has the highest command priority, and Pr. 00-29 functions in standard HOA mode.

 When you do not set Pr.00-29 to 0, the Local / Remote function is enabled, and the top right corner of digital keypad KPC-CC01 (optional) displays LOC or REM (the display is available

when KPC-CC01 is installed with firmware version higher than version 1.021). Set the LOCAL frequency and operation source with Pr.00-20 and Pr.00-21. Set the REMOTE frequency and operation source with Pr.00-30 and Pr.00-31. Select or switch LOC / REM mode with the digital keypad KPC-CC01 (optional) or set the multi-function input terminal MI = 56. The AUTO key of the digital keypad is for the REMOTE function, and HAND key is for the LOCAL function.

- 📖 When you set the external terminal (MI) to 56 for LOC / REM mode selection, if you set Pr.00-29 to 0, then the external terminal function is disabled.
- 📖 When you set the external terminal (MI) to 56 for LOC / REM mode selection, if Pr.00-29 is not set to 0, then AUTO / HAND key is disabled, and the external terminal has the highest command priority.

### **00-30** Master Frequency Command (HAND) Source

Default: 0

- Settings
- 0: Digital keypad
  - 1: RS-485 communication
  - 2: External analog input (Pr. 03-00)
  - 3: External UP/DOWN terminal (multi-function input terminal)
  - 4: Pulse input without direction command (Pr. 10-16 without direction)
  - 5: Pulse input with direction command (Pr. 10-16)
  - 6: CANopen communication card
  - 8: Communication card (does not include CANopen card)

- 📖 Determines the master frequency source in HAND mode.

### **00-31** Operation Command (HAND) Source

Default: 0

- Settings
- 0: Digital keypad
  - 1: External terminals. Keypad STOP disabled.
  - 2: RS-485 communication. Keypad STOP disabled.
  - 3: CANopen communication card
  - 5: Communication card (does not include CANopen card)

- 📖 Set the source of the master frequency in HAND mode.
- 📖 Pr. 00-20 and Pr. 00-21 are for the settings of frequency source and operation source in AUTO mode. Pr. 00-30 and Pr. 00-31 are for the settings of frequency source and operation source in HAND mode. You can switch the AUTO / HAND mode with the keypad KPC-CC01 (optional) or the multi-function input terminal (MI) to set the master frequency source.
- 📖 The default for the frequency source or operation source is for AUTO mode. It returns to AUTO mode whenever cycle the power. If you use a multi-function input terminal to switch between AUTO and HAND mode, the highest priority is the multi-function input terminal. When the external terminal is OFF, the drive does not accept any operation signal and cannot execute JOG.

## 00-32 Digital Keypad STOP Function

Default: 0

- Settings 0: Disable STOP key  
1: Enable STOP key

 This parameter is valid when the digital keypad is not set as the operation source (Pr. 00-21≠0).  
When Pr. 00-21=0, the STOP key on the digital keypad is not affected by the parameter.

## 00-40 Homing mode

Default: 0000h

Settings:

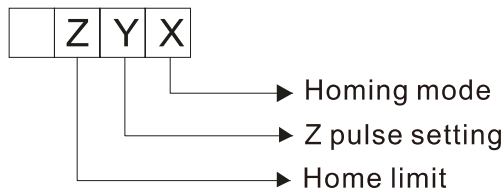

Note: Forward run = clockwise (CW)  
Reverse run = counterclockwise (CCW)

- X** 0: Forward run to home. Set PL forward limit as checkpoint.  
1: Reverse run (CCW) to home. Set NL reverse limit (CCWL) as checkpoint.  
2: Forward run to home. Set ORG : OFF→ON as checkpoint.  
3: Reverse to home. Set ORG : OFF→ON as checkpoint.  
4: Forward run and search for Z-pulse as checkpoint.  
5: Reverse run and search for Z-pulse as checkpoint.  
6: Forward run to home. Set ORG: ON→OFF as checkpoint.  
7: Reverse run to home. Set ORG : ON→OFF as checkpoint.  
8: Define current position as home.
- Y** Set X to 0, 1, 2, 3, 6, 7  
0: reverse run to Z pulse  
1: continue forward run to Z pulse  
2: Ignore Z pulse
- Z** When home limit is reached, set X to 2, 3, 4, 5, 6, 7 first.  
0: display error  
1: reverse the direction

 Homing action is controlled by Pr. 00-40, Pr. 00-41, Pr. 00-42 and Pr. 02-01–02-08.

1. When Y=0, X=0 or Y=0, X=2

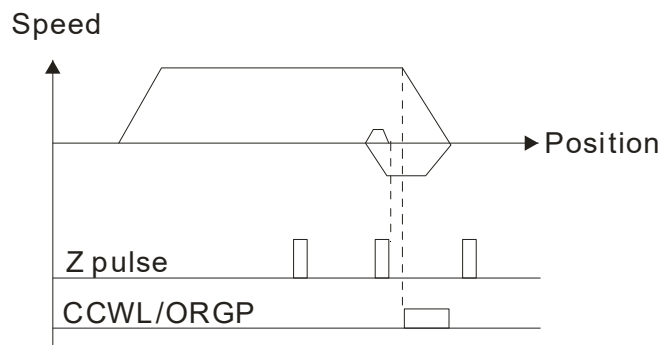

2. When Y=0, X=1 or Y=0, X=3

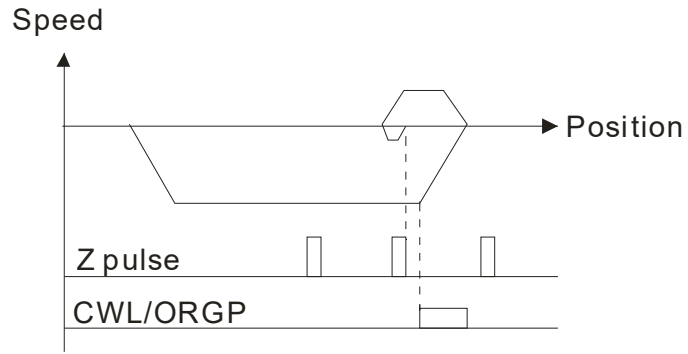

3. When Y=1, X=2

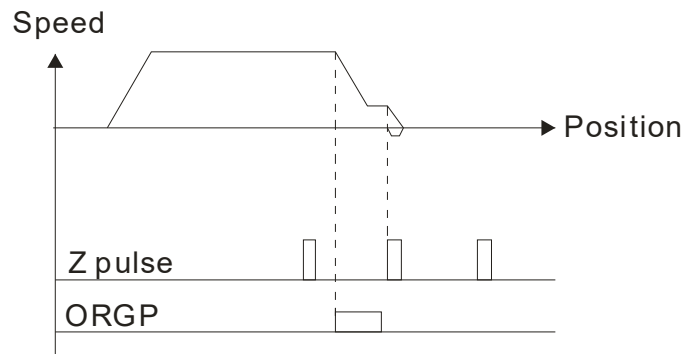

4. When Y=1, X=3

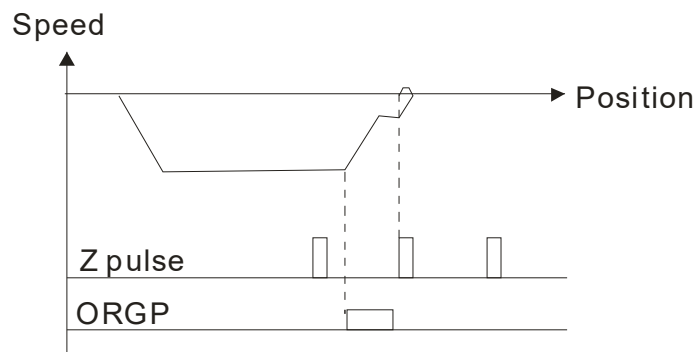

5. When Y=2, X=2

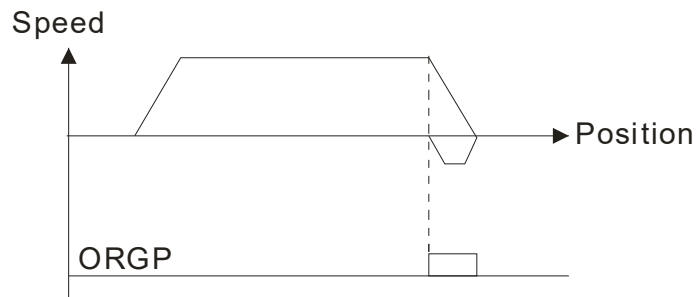

6. When Y=2, X=3

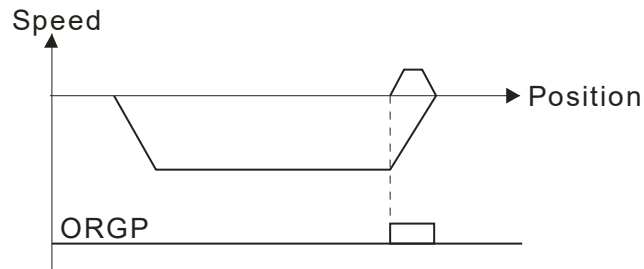

7. When Y=2, X=4

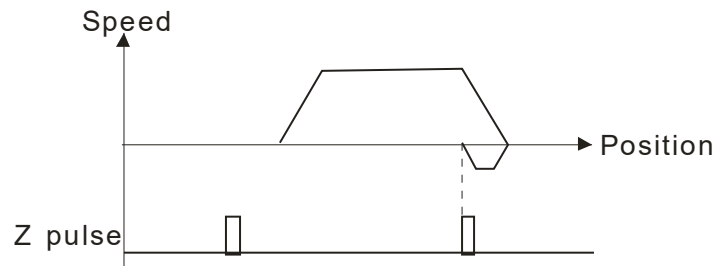

8. When Y=2, X=5

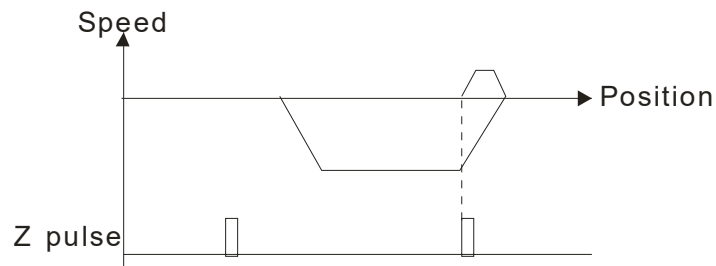

↗ **00-41** Homing by Frequency 1

Default: 8.00

Settings 0.00–599.00Hz

↗ **00-42** Homing by Frequency 2

Default: 2.00

Settings 0.00–599.00Hz

📖 Controlled by multi-function input terminal Pr. 02-01–02-08 (44–47).

44: Reverse direction homing (NL)

45: Forward direction homing (PL)

46: Homing (ORG)

47: Homing function enabled

📖 If the drive is not controlled by CAN or PLC, when setting Pr. 00-10 = 1 (Control mode = P2P position control), set the external input terminal to 47 (homing function enable) for homing.

📖 When Pr. 00-10 is set to 3, after homing is complete, you must set control mode (Pr. 00-10 = 1) to execute P2P position control.

↗ **00-48** Display Filter Time (Current)

Default: 0.100

Settings 0.001–65.535 sec.

📖 Minimize the current fluctuation displayed by digital keypad.



↗ **00-49** Display Filter Time (Keypad)

Default: 0.100

Settings 0.001–65.535 sec.

---

📖 Minimize the display value fluctuation displayed by digital keypad.

**00-50** Software Version (Date)

Default: #####

Settings Read only

---

📖 Displays the current drive software version by date.

## 01 Basic Parameters

✎ You can be set this parameter during operation.

**01-00** Maximum Operation Frequency

Default: 60.00 / 50.00

Settings 00.00–599.00 Hz

📖 Determines the AC motor drive's maximum operation frequency range. This setting corresponds to the maximum value for the analog input frequency setting signal (0 – +10 V, 4–20 mA, 0–20 mA, ±10 V).

📖 In normal load mode:

- VF, SVC, VFPG, FOCPG: 0–599 Hz
- FOC sensorless (IM/PM): 0–300Hz / 500 Hz

📖 In heavy load mode:

- Output range: 0–300 Hz

**01-01** Output Frequency of Motor 1 ( base frequency and motor rated frequency )

**01-35** Output Frequency of Motor 2 ( base frequency and motor rated frequency )

Default: 60.00 / 50.00

Settings 0.00–599.00 Hz

📖 Set the value according to the motor's rated frequency from the motor's nameplate. If the motor's rated frequency is 60 Hz, set the value to 60 Hz. If the motor's rated frequency is 50 Hz, set the value to 50 Hz.

**01-02** Output Voltage of Motor 1 ( base frequency and motor rated frequency )

**01-36** Output Voltage of Motor 2 ( base frequency and motor rated frequency )

Default:

200.0 / 400.0 / 575.0 / 660.0

Settings 230V series: 0.0–255.0 V

460V series: 0.0–510.0 V

575V series: 0.0–637.0 V

690V series: 0.0–765.0 V

📖 Set the value according to the motor's rated voltage from the motor's nameplate. If the motor's rated voltage is 220 V, set the value to 220.0 V. If the motor's rated voltage is 200 V, set the value to 200.0 V.

📖 There are a wide variety of motors, but the power system for each country is different. The convenient and economical way to solve this problem is to use an AC motor drive, which can deal with different voltages and frequencies, while supporting the original characteristics and life of the motor.

**01-03** Mid-point Frequency 1 of Motor 1

Default: 3.00

Settings 0.00–599.00 Hz

↗ <b>01-04</b>	Mid-point Voltage 1 of Motor 1	Default: 11.0 / 22.0 / 0.0 / 0.0
	Settings 230V series: 0.0–240.0 V 460V series: 0.0–480.0 V 575V series: 0.0–637.0 V 690V series: 0.0–720.0 V	
<b>01-37</b>	Mid-point Frequency 1 of Motor 2	Default: 3.00
	Settings 0.00–599.00 Hz	
↗ <b>01-38</b>	Mid-point Voltage 1 of Motor 2	Default: 11.0 / 22.0 / 0.0 / 0.0
	Settings 230V series: 0.0–240.0 V 460V series: 0.0–480.0 V 575V series: 0.0–637.0 V 690V series: 0.0–720.0 V	
<b>01-05</b>	Mid-point Frequency 2 of Motor 1	Default: 1.50
	Settings 0.00–599.00 Hz	
↗ <b>01-06</b>	Mid-point Voltage 2 of Motor 1	Default: 5.0 / 10.0 / 0.0 / 0.0
	Settings 230V series: 0.0–240.0 V 460V series: 0.0–480.0 V 575V series: 0.0–637.0 V 690V series: 0.0–720.0 V	
<b>01-39</b>	Mid-point Frequency 2 of Motor 2	Default: 1.50
	Settings 0.00–599.00 Hz	
↗ <b>01-40</b>	Mid-point Voltage 2 of Motor 2	Default: 5.0 / 10.0 / 0.0 / 0.0
	Settings 230V series: 0.0–240.0 V 460V series: 0.0–480.0 V 575V series: 0.0–637.0 V 690V series: 0.0–720.0 V	
<b>01-07</b>	Min. Output Frequency of Motor 1	Default: 0.50
	Settings 0.00–599.00 Hz	

⚡ **01-08** Min. Output Voltage of Motor 1

Default:  
1.0 / 2.0 / 0.0 / 0.0

Settings 230V series: 0.0–240.0 V  
460V series: 0.0–480.0 V  
575V series: 0.0–637.0 V  
690V series: 0.0–720.0 V

**01-41** Min. Output Frequency of Motor 2

Default: 0.50

Settings 0.00–599.00 Hz

⚡ **01-42** Min. Output Voltage of Motor 2

Default:  
1.0 / 2.0 / 0.0 / 0.0

Settings 230V series: 0.0–240.0 V  
460V series: 0.0–480.0 V  
575V series: 0.0–637.0 V  
690V series: 0.0–720.0 V

- 📖 The V/F curve setting is usually set by the motor’s allowable loading characteristics. If the loading characteristics exceeds the loading limit of the motor, you must pay more attention to the heat dissipation, dynamic balance, and bearing lubrication of the motor.
- 📖 If the voltage is too high when the motor is at low frequencies, it may cause motor damage, overheating, and may trigger stalling or over-current protection. To prevent motor damage or motor fault, be careful when you set the voltage.
- 📖 Pr. 01-35 to Pr. 01-42 is the V/F curve for the motor 2. When multi-function input terminals Pr. 02-01–02-08 and Pr. 02-26–Pr. 02-31 are set to 14 and enabled, the AC motor drive will act as the 2nd V/F curve.
- 📖 The diagram below shows the V/F curve for motor 1. You can also find the V/F curve for motor 2 from the same diagram.

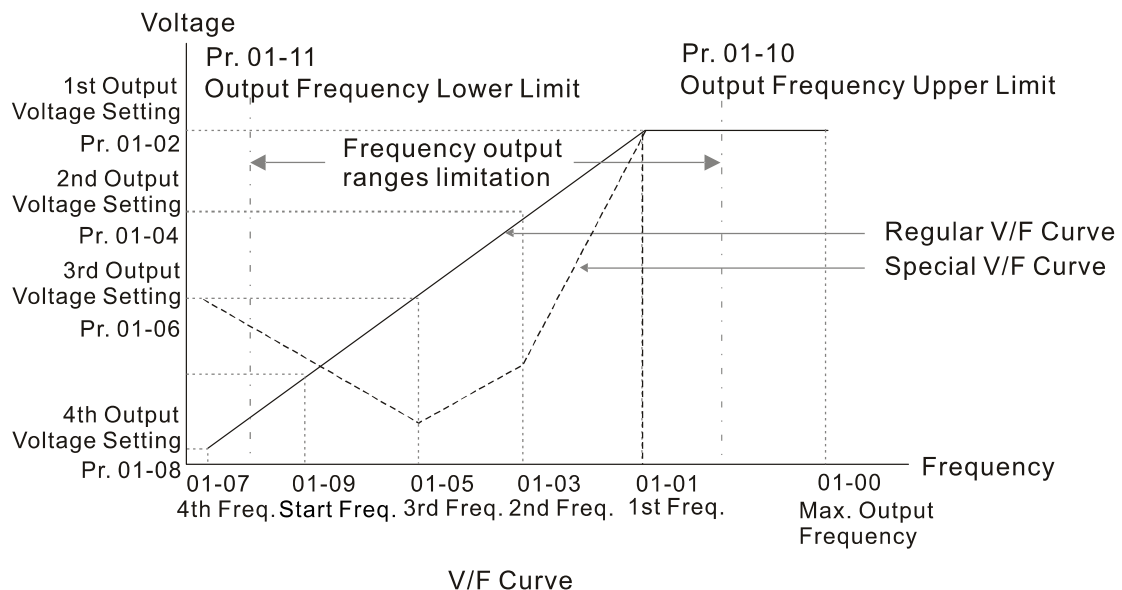

Common settings for the V/F curve:

(1) General purpose

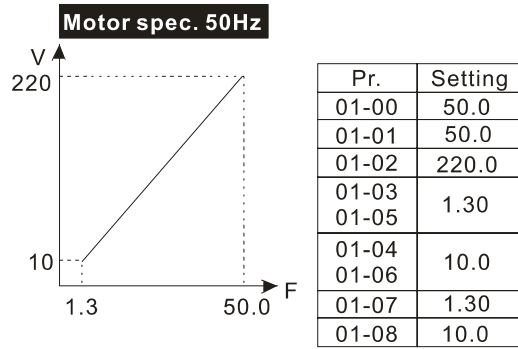
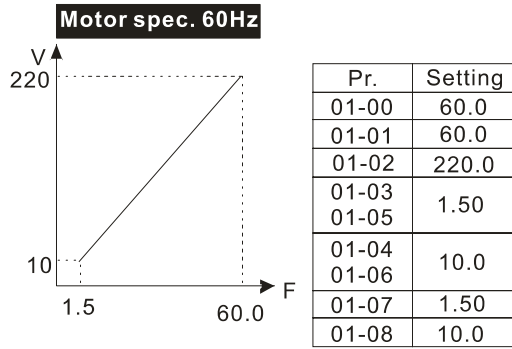

(2) For fan and hydraulic machinery

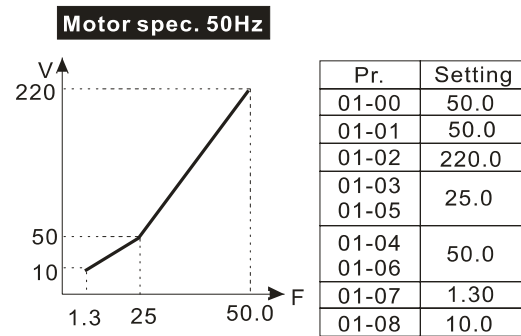
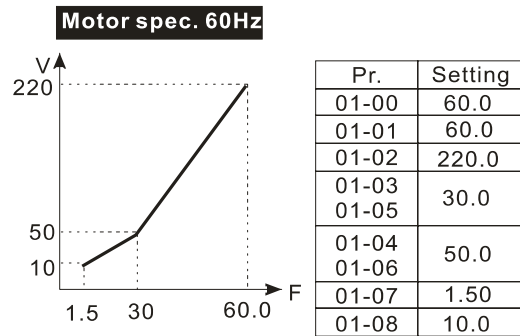

(3) High starting torque

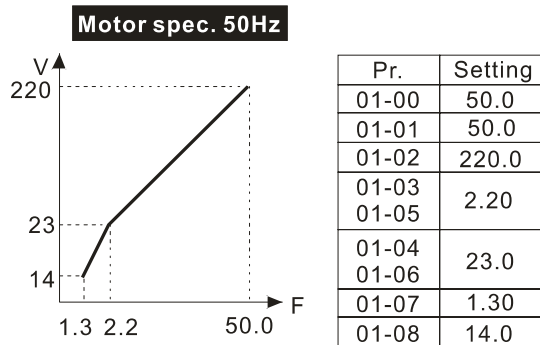
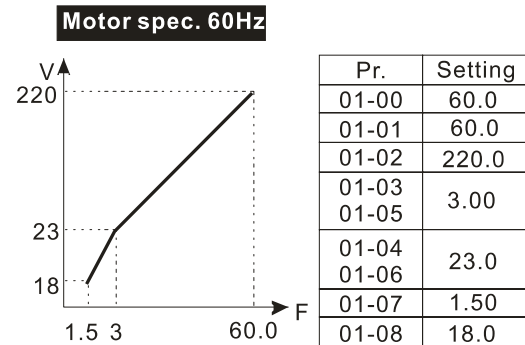

**01-09** Start-Up Frequency

Default: 0.50

Settings 0.00–599.00Hz

When the starting frequency is higher than the minimum output frequency, the drives' output is from the starting frequency to the setting frequency. Refer to the following diagram for details.

Fcmd: frequency command

Fstart: start-up frequency (Pr. 01-09)

fstart: actual start-up frequency of drive

Fmin: 4th output frequency setting (Pr. 01-07/ Pr. 01-41)

Flow: output frequency lower limit (Pr. 01-11)

When Fcmd > Fmin and Fcmd < Fstart:

If Flow < Fcmd, drive runs directly by Fcmd.

If Flow ≥ Fcmd, drive runs by Fcmd, then rises to Flow according to acceleration time.

The output frequency goes directly to 0 when decelerating to Fmin.

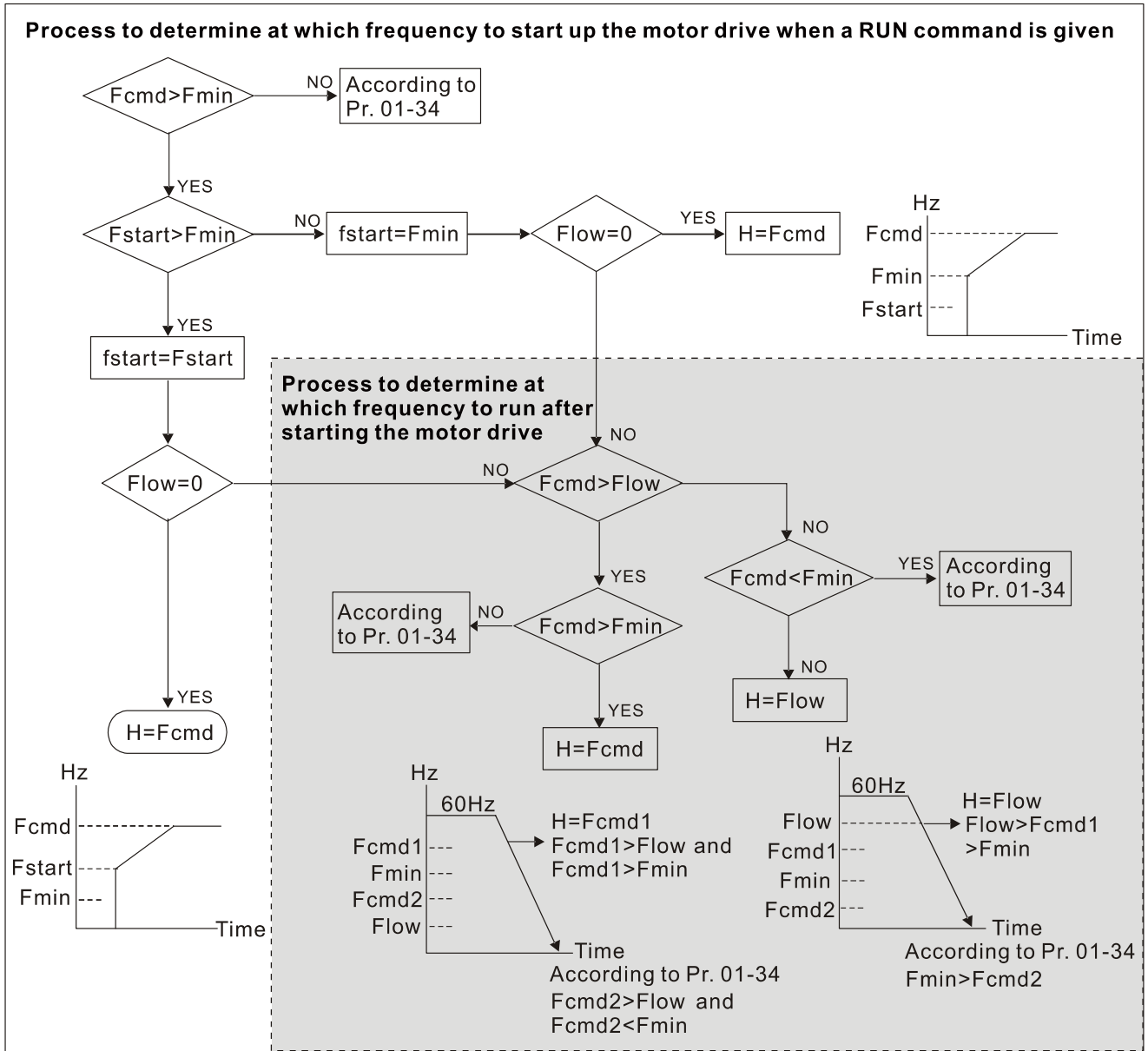

✎ **01-10** Output Frequency Upper Limit

Default: 599.00

Settings 0.00–599.00Hz

✎ **01-11** Output Frequency Lower Limit

Default: 0.00

Settings 0.00–599.00Hz

- 📖 Use the upper and lower limit output frequency settings to limit the actual output frequency. If the frequency setting is higher than the upper limit (Pr. 01-10), the drive uses the upper limit frequency. If output frequency is lower than lower limit (Pr. 01-11) and frequency setting is higher than minimum frequency (Pr. 01-07), the drive uses the lower limit frequency. Set the upper limit frequency > lower limit frequency (Pr.01-10 setting value must be > Pr.01-11 setting value).
- 📖 The upper output frequency limits the maximum output frequency of the drive. If the frequency setting is higher than Pr.01-10, the Pr. 01-10 setting limits the output frequency.
- 📖 When the drive starts the slip compensation function (Pr.07-27) or PID feedback control, the drive output frequency may exceed frequency command but is still limited by this setting.

Related parameters: Pr.01-00 Maximum Operation Frequency, and Pr.01-11 Output Frequency Lower Limit

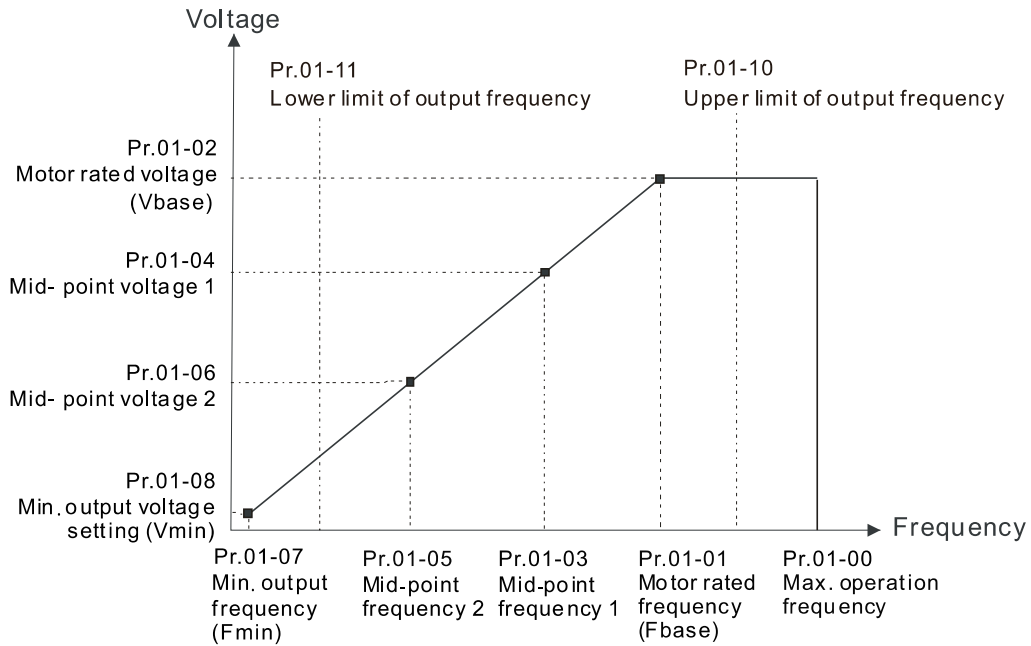

- ☞ The lower output frequency limits the minimum output frequency of the drive. When the drive frequency command or feedback control frequency is lower than this setting, the lower limit of the frequency limits the drive output frequency.
- ☞ When the drive starts, it operates from the minimum output frequency (Pr. 01-07) and accelerates to the setting frequency. It is not limited by the lower output frequency settings.
- ☞ Use the output frequency upper and lower limit settings to prevent operator misuse, overheating caused by operating at a too low frequency, or damage caused by excessive speed.
- ☞ If the output frequency upper limit setting is 50Hz and the frequency setting is 60Hz, the maximum output frequency is 50 Hz.
- ☞ If the output frequency lower limit setting is 10Hz and the minimum operation frequency setting (Pr. 01-07) is 1.5 Hz, the drive operates at 10Hz when the frequency command is higher than Pr. 01-07 and less than 10 Hz. If the frequency command is less than Pr. 01-07, the drive stays in ready status with no output.
- ☞ If the frequency output upper limit is 60Hz and the frequency setting is also 60Hz, only the frequency command is limited in 60 Hz. The actual frequency output may exceed 60 Hz if the drive starts the slip compensation function.

↗	<b>01-12</b>	Acceleration Time 1
↗	<b>01-13</b>	Deceleration Time 1
↗	<b>01-14</b>	Acceleration Time 2
↗	<b>01-15</b>	Deceleration Time 2
↗	<b>01-16</b>	Acceleration Time 3
↗	<b>01-17</b>	Deceleration Time 3
↗	<b>01-18</b>	Acceleration Time 4
↗	<b>01-19</b>	Deceleration Time 4
↗	<b>01-20</b>	JOG Acceleration Time

## 01-21 JOG Deceleration Time

Default: 10.00

The default of motor drive with 30HP  
and above: 60.00 / 60.0

Settings Pr.01-45=0: 0.00–600.00 seconds

Pr.01-45=1: 0.00–6000.0 seconds

- 📖 Use the acceleration time to determine the time required for the AC motor drive to accelerate from 0.00Hz to maximum output frequency (Pr. 01-00).
- 📖 The acceleration and deceleration time are invalid when using Pr. 01-44 Auto-acceleration and Auto-deceleration Setting.
- 📖 Select the acceleration and deceleration time 1, 2, 3, and 4 with the multi-function input terminals settings. The defaults are acceleration and deceleration time 1.
- 📖 With the enabled torque limits and stall prevention functions, the actual acceleration and deceleration time are longer than the above action time.
- 📖 Note that setting the acceleration time too short may trigger the protection function (Pr. 06-03 Over-current Stall Prevention during Acceleration or Pr. 06-01 Over-voltage Stall Prevention).
- 📖 Note that setting the acceleration time too short may cause motor damage or trigger drive protection due to over-current during acceleration.
- 📖 Note that setting the deceleration time too short may cause motor damage or trigger drive protection due to over-current during deceleration or over-voltage.
- 📖 Use suitable brake resistor (refer to Chapter 07 Optional Accessories) to decelerate in a short time and prevent over-voltage.
- 📖 When you enable Pr. 01-24–Pr.01-27, the actual acceleration and deceleration time are longer than the setting.

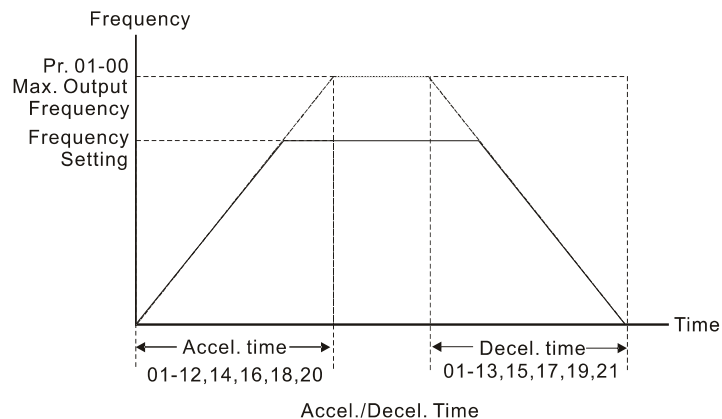

## 01-22 JOG Frequency

Default: 6.00

Settings 0.00–599.00 Hz

- 📖 You can use both the external terminal JOG and F1 key on the optional keypad KPC-CC01 to set the JOG function. When the JOG command is ON, the AC motor drive accelerates from 0 Hz to the JOG frequency (Pr. 01-22). When the JOG command is OFF, the AC motor drive decelerates from the JOG frequency to stop. The JOG acceleration and deceleration time (Pr. 01-20, Pr. 01-21) are the time to accelerate from 0.00 Hz to JOG frequency (Pr. 01-22).
- 📖 You cannot execute the JOG command when the AC motor drive is running. When the JOG command is executing, other operation commands are invalid.



➤ **01-23** First / Fourth Acceleration / Deceleration Frequency

Default: 0.00

Settings 0.00–599.00 Hz

- 📖 This function does not require the external terminal switching function; it switches the acceleration and deceleration time automatically by the Pr.01-23 setting. If you set the external terminal, it is based on the external terminal first, and not on Pr.01-23.
- 📖 When using this function, set the S-curve acceleration time to 0 if the fourth acceleration time is set too short.

As the usage of Pr. 01-23, for instance, under Pr. 01-00=80 Hz and Pr. 01-23=40 Hz:

- a. If Pr. 01-02=10s, Pr. 01-18=6s, then the 0–40 Hz acceleration time is 3s and 40–80 Hz acceleration time is 5s.
- b. If Pr. 01-13=8s, Pr. 01-19=2s, then 80–40 Hz deceleration time is 4s and 40–0 Hz deceleration time is 1s.

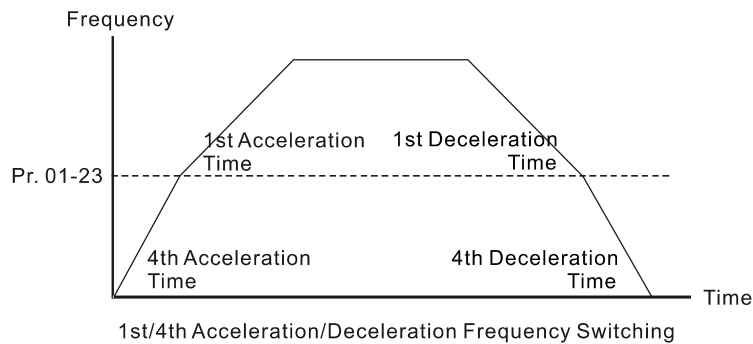

➤ **01-24** S-curve Acceleration Begin Time 1

➤ **01-25** S-curve Acceleration Arrival Time 2

➤ **01-26** S-curve Deceleration Begin Time 1

➤ **01-27** S-curve Deceleration Arrival Time 2

Default: 0.20

Settings Pr.01-45=0: 0.00–25.00 seconds

Pr.01-45=1: 0.00–250.0 seconds

- 📖 It Sets a slow start when the drive begins to accelerate at the start. The acceleration and deceleration curve adjust the S-curve acceleration and deceleration according to the parameter value. When you enable this function, the drive has a different acceleration and deceleration curve based on the acceleration and deceleration time.
- 📖 The S-curve function is disabled when you set the acceleration and deceleration time to 0.
- 📖 When Pr. 01-12, Pr. 01-14, Pr. 01-16, Pr. 01-18 ≥ Pr. 01-24 and Pr. 01-25, the actual acceleration time = Pr. 01-12, Pr. 01-14, Pr. 01-16, Pr. 01-18 + (Pr. 01-24 + Pr. 01-25)/2
- 📖 When Pr. 01-13, Pr. 01-15, Pr. 01-17, Pr. 01-19 ≥ Pr. 01-26 and Pr. 01-27, the actual deceleration time = Pr. 01-13, Pr. 01-15, Pr. 01-17, Pr. 01-19 + (Pr. 01-26 + Pr. 01-27)/2

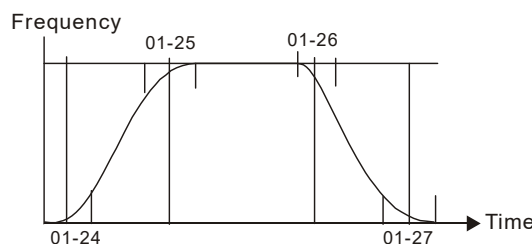

01-28	Skip Frequency 1 (upper limit)
01-29	Skip Frequency 1 (lower limit)
01-30	Skip Frequency 2 (upper limit)
01-31	Skip Frequency 2 (lower limit)
01-32	Skip Frequency 3 (upper limit)
01-33	Skip Frequency 3 (lower limit)

Default: 0.00

Settings 0.00~599.00Hz

- 📖 Set the AC motor drive's skip frequency. The drive's frequency setting skips these frequency ranges. However, the frequency output is continuous. There are no limits for these six parameters and you can combine them. Pr.01-28 does not need to be greater than Pr.01-29; Pr.01-30 does not need to be greater than Pr.01-31; Pr.01-32 does not need to be greater than Pr.01-33. Pr.01-28–01-33 can be set as required. There is no size distinction among these six parameters.
- 📖 These parameters set the skip frequency ranges for the AC motor drive. You can use this function to avoid frequencies that cause mechanical resonance. The skip frequencies are useful when a motor has resonance vibration at a specific frequency bandwidth. Skipping this frequency avoids the vibration. There are three frequency skip zones available.
- 📖 You can set the Frequency command (F) within the range of skip frequencies. Then the output frequency (H) is limited to the lower limit of skip frequency ranges.
- 📖 When accelerating and decelerating, the output frequency still passes the skip frequency ranges.

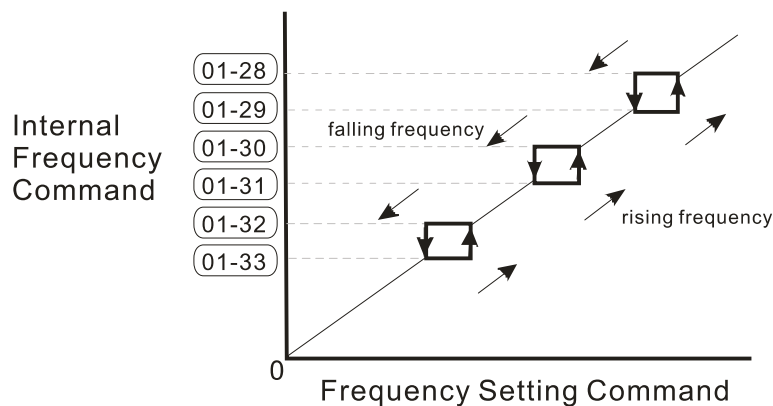
**01-34** Zero-speed Mode

Default: 0

Settings 0: Waiting for output  
 1: Zero-speed operation  
 2: Minimum frequency (Refer to Pr. 01-07, Pr. 01-41)

- 📖 When the frequency command of drive is less than  $F_{min}$  (Pr. 01-07 or Pr. 01-41), the drive operates according to the setting value.
- 📖 0: the AC motor drive is in waiting mode without voltage output from terminals U, V, W.
- 📖 1: the drive executes the DC brake by  $V_{min}$  (Pr. 01-08 and Pr. 01-42) in V/F, FOC Sensorless, and SVC modes. And it executes zero-speed operation in VFPG and FOCPG mode.
- 📖 2: the AC motor drive runs using  $F_{min}$  (Pr. 01-07, Pr. 01-41) and  $V_{min}$  (Pr. 01-08, Pr. 01-42) in V/F, VFPG, SVC, FOC Sensorless and FOCPG modes.

In V/F, VFPG, SVC and FOC Sensorless modes

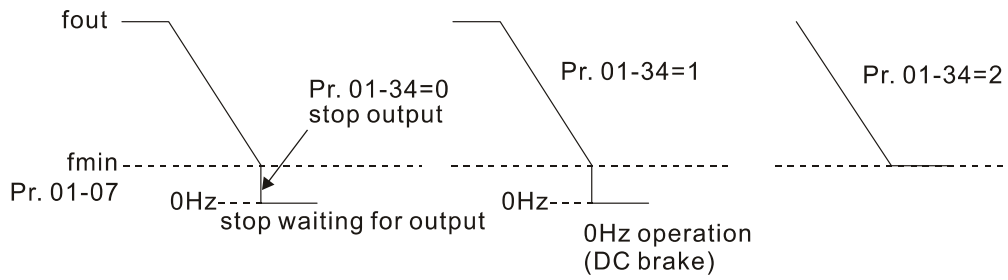

In FOCPG mode, when Pr. 01-34 is set to 2, the AC motor drive operates according to the setting.

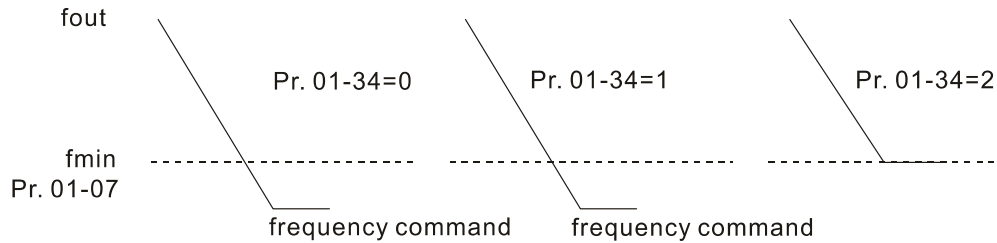

### **01-43** V/F Curve Selection

Default: 0

- Settings
- 0: V/F curve determined by Pr. 01-00–01-08
  - 1: 1.5<sup>th</sup> V/F curve
  - 2: 2<sup>nd</sup> V/F curve
  - 3: 60Hz, voltage saturation in 50Hz
  - 4: 72Hz, voltage saturation in 60Hz
  - 5: 50Hz, decrease gradually with cube
  - 6: 50Hz, decrease gradually with square
  - 7: 60Hz, decrease gradually with cube
  - 8: 60Hz, decrease gradually with square
  - 9: 50Hz, medium starting torque
  - 10: 50Hz, high starting torque
  - 11: 60Hz, medium starting torque
  - 12: 60Hz, high starting torque
  - 13: 90Hz, voltage saturation in 60Hz
  - 14: 120Hz, voltage saturation in 60Hz
  - 15: 180Hz, voltage saturation in 60Hz

When setting to 0, refer to Pr. 01-01–01-08 for the motor 1 V/F curve. For motor 2, refer to Pr. 01-35–01-42.

When setting to 1 or 2, the second and third voltage frequency settings are invalid.

If the load on the motor is a variable torque load (torque is in direct proportion to rotating speed, such as the load of a fan or a pump), the load torque is low at low rotating speed. Decreasing the input voltage to make the magnetic field of the input current smaller and reduce flux loss and iron loss for the motor to increase efficiency.

When you set the V/F curve to high power, it has lower torque at low frequency, and the drive is not suitable for rapid acceleration and deceleration. Do NOT use this parameter for rapid acceleration and deceleration.

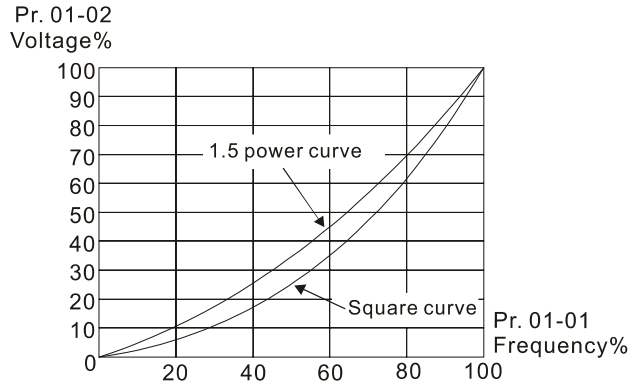

**01-44** Auto-acceleration and Auto-deceleration Setting

Default: 0

- Settings
- 0: Linear acceleration and linear deceleration
  - 1: Auto-acceleration and linear deceleration
  - 2: Linear acceleration and auto-deceleration
  - 3: Auto-acceleration and auto-deceleration
  - 4: Stall prevention by auto-acceleration and auto-deceleration (limited by Pr. 01-12 to Pr. 01-21)

- 0 (linear acceleration and linear deceleration): the drive accelerates and decelerates according to the setting for Pr. 01-12–01-19.
- 1 or 2 (auto/linear acceleration and auto/linear deceleration): the drive reduces the mechanical vibration and prevents the complicated auto-tuning processes. It does not stall during acceleration and has no need for a brake resistor. It can also improve operation efficiency and save energy.
- 3 (auto-acceleration and deceleration—decelerate by actual load): the drive auto-detects the load torque and accelerates from the fastest acceleration time and smoothest start current to the setting frequency. When decelerating, the drive auto-detects the load re-generation and stops the motor smoothly with the fastest deceleration time.
- 4 (stall prevention by auto-acceleration and deceleration—refer to acceleration and deceleration time): if the acceleration and deceleration is within a reasonable range, the drive accelerates and decelerates according to Pr.01-12–01-19. If the acceleration and deceleration time is too short, the actual acceleration and deceleration time are greater than the acceleration and deceleration time settings.

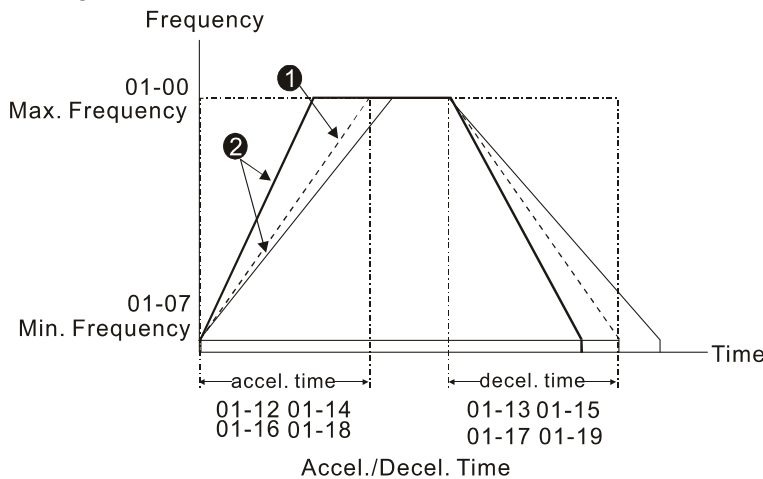

- ① When Pr. 01-44 is set to 0.
- ② When Pr. 01-44 is set to 3.

**01-45** Time Unit for Acceleration / Deceleration and S Curve

Default: 0

Settings 0: Unit 0.01 sec.  
1: Unit 0.1 sec.

**01-46** CANopen Quick Stop Time

Default: 1.00





Settings Pr. 01-45=0: 0.00–600.00 sec.  
Pr. 01-45=1: 0.0–6000.0 sec.

 Use this to set the time to decelerate from the maximum operation frequency (Pr. 01-00) to 0.00Hz by CANopen control.

**01-49** Regenerative Energy Restriction Control Method

Default: 0

Settings 0: Disable  
1: Over voltage energy restriction  
2: Traction energy control (TEC)

-  Pr.01-49=0: the drive decelerates or stops based on original setting of deceleration.
-  Pr.01-49=1: when decelerating, the motor drive is controlled based on Pr. 06-01 setting and the DC BUS regenerative voltage. When the DC BUS voltage reaches Pr. 06-01 \* 95%, the controller is activated. When Pr. 06-01=0, the drive is controlled referring to the working voltage and DC BUS regenerative voltage. The drive decelerates according to the setting of deceleration time, and the actual maximum deceleration time is not less than the deceleration time setting.
-  The actual deceleration time of the motor is greater than the deceleration time setting due to the over voltage stall prevention action.
-  When Pr.01-49=2, it can auto-tuning the output frequency and output voltage based on the capability of the drive, increase consumption of the DC BUS energy, so the actual deceleration time meets the parameter setting as possible as it could. When the application cannot reach the expected deceleration time and therefore cause over-voltage error, this setting will be suggested to use.

## 02 Digital Input/Output Parameter

✎ This parameter can be set during operation.

**02-00** Two-wire / Three-wire Operation Control

Default: 0

Settings 0: Two-wire mode 1, power on for operation control

1: Two-wire mode 2, power on for operation control

2: Three-wire, power on for operation control

📖 This parameter sets the configuration of the terminals (Pr.00-21=1 or Pr.00-31=1) which control the operation. There are three different control modes listed in the following table.

Pr.02-00	Control Circuits of the External Terminal
Settings: 0 2-wire mode 1 FWD/STOP REV/STOP	<p>FWD ("OPEN": STOP) ("CLOSE": FWD) REV ("OPEN": STOP) ("CLOSE": REV) DCM</p> <p style="text-align: right;"><b>VFD-C</b></p>
Settings: 1 2-wire mode 2 RUN/STOP REV/FWD	<p>FWD ("OPEN": STOP) ("CLOSE": RUN) REV ("OPEN": FWD) ("CLOSE": REV) DCM</p> <p style="text-align: right;"><b>VFD-C</b></p>
Settings: 2 3-wire operation control	<p>FWD ("CLOSE": RUN) MI1 ("OPEN": STOP) REV/FWD ("OPEN": FWD) ("CLOSE": REV) DCM</p> <p style="text-align: right;"><b>VFD-C</b></p>

**02-01** Multi-function Input Command 1 (MI1)

Default: 1

**02-02** Multi-function Input Command 2 (MI2)

Default: 2

**02-03** Multi-function Input Command 3 (MI3)

Default: 3

**02-04** Multi-function Input Command 4 (MI4)

Default: 4

**02-05** Multi-function Input Command 5 (MI5)

**02-06** Multi-function Input Command 6 (MI6)

**02-07** Multi-function Input Command 7 (MI7)

**02-08** Multi-function Input Command 8 (MI8)

**02-26** Input terminal of I/O extension card (MI10)

**02-27** Input terminal of I/O extension card (MI11)

**02-28** Input terminal of I/O extension card (MI12)





02-29	Input terminal of I/O extension card (MI13)
02-30	Input terminal of I/O extension card (MI14)
02-31	Input terminal of I/O extension card (MI15)

Default: 0

## Settings

- 0: No function
- 1: Multi-step speed command 1/ multi-step position command 1
- 2: Multi-step speed command 2/ multi-step position command 2
- 3: Multi-step speed command 3/ multi-step position command 3
- 4: Multi-step speed command 4/ multi-step position command 4
- 5: Reset
- 6: JOG command (By KPC-CC01 or external control)
- 7: Acceleration / deceleration speed inhibit
- 8: The 1<sup>st</sup>, 2<sup>nd</sup> acceleration / deceleration time selection
- 9: The 3<sup>rd</sup>, 4<sup>th</sup> acceleration / deceleration time selection
- 10: EF Input (Pr. 07-20)
- 11: Base Block (B.B) input from external
- 12: Output stop
- 13: Cancel the setting of auto-acceleration / auto-deceleration time
- 14: Switch between motor 1 and motor 2
- 15: Rotating speed command from AVI
- 16: Rotating speed command from ACI
- 17: Rotating speed command from AUI
- 18: Forced to stop (Pr. 07-20)
- 19: Digital up command
- 20: Digital down command
- 21: PID function disabled
- 22: Clear the counter
- 23: Input the counter value (MI6)
- 24: FWD JOG command
- 25: REV JOG command
- 26: TQC / FOC mode selection
- 27: ASR1/ ASR2 selection
- 28: Emergency stop (EF1)
- 29: Signal confirmation for Y-connection
- 30: Signal confirmation for  $\Delta$ -connection
- 31: High torque bias (Pr. 11-30)
- 32: Middle torque bias (Pr. 11-31)
- 33: Low torque bias (Pr. 11-32)
- 34: Switch between multi-step position and multi-step speed control
- 35: Enable single-point position control
- 36: Enable multi-step position learning function (valid at stop)
- 37: Enable full position control pulse command input
- 38: Disable write EEPROM function
- 39: Torque command direction
- 40: Force coasting to stop
- 41: HAND switch
- 42: AUTO switch
- 43: Enable resolution selection (Pr. 02-48)
- 44: Reverse direction homing (NL)
- 45: Forward direction homing (PL)
- 46: Homing (ORG)
- 47: Enable homing function
- 48: Mechanical gear ratio switch
- 49: Enable drive
- 50: Slave dEb action to execute
- 51: Selection for PLC mode bit0

- 52: Selection for PLC mode bit1
- 53: Trigger CANopen quick stop
- 55: Brake release
- 56: Local / Remote Selection

-  This parameter selects the functions for each multi-function terminal.
-  The terminals of Pr. 02-26~Pr. 02-31 are set as the corresponded parameters of MI10~MI13 when using with optional card EMC-D42A. Pr. 02-30~Pr. 02-31 are virtual terminals.
-  When being used as a virtual terminal, it needs to change the status (0/1: ON/OFF) of bit8~15 of Pr. 02-12 by digital keypad KPC-CC01 or communication.
-  If Pr. 02-00 is set to three-wire operation control, terminal MI1 is for the STOP contact. The function set previously for this terminal is automatically invalid.

### Summary of function settings

Take the normally opened contact (N.O.) for example, ON: contact is closed, OFF: contact is open

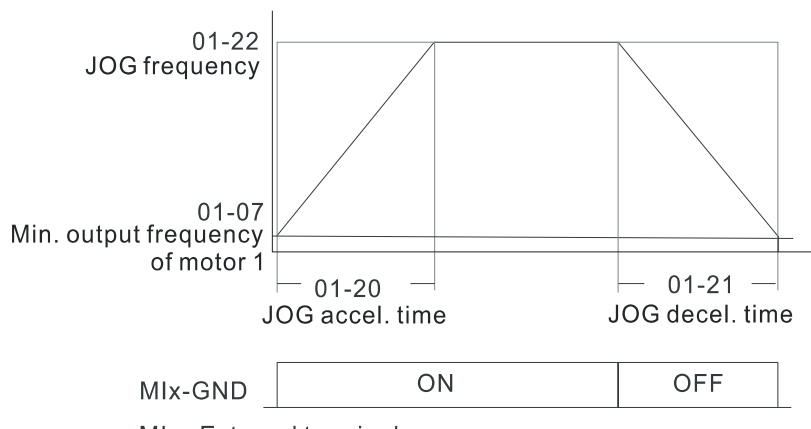
Settings	Functions	Descriptions
0	No Function	
1	Multi-step speed command 1 / multi-step position command 1	You can set 15 steps of speed or 15 positions with the digital status of these 4 terminals. You can use 16-steps of speed if you include the master speed when setting as 15 steps of speed (refer to Parameter Group 04 Multi-step Speed Parameters).
2	Multi-step speed command 2 / multi-step position command 2	
3	Multi-step speed command 3 / multi-step position command 3	
4	Multi-step speed command 4 / multi-step position command 4	
5	Reset	Use this terminal to reset the drive after clearing a drive fault.
6	JOG Command	<p>This function is valid when the source of operation command is external terminals.</p> <p>Before executing this function, wait for the drive stop completely. You can execute STOP command via the keypad after enabling the function through Pr.00-32. Once the external terminal receives OFF command, the motor stops in the JOG deceleration time. Refer to Pr. 01-20~Pr. 01-22 for details.</p>  <p>MIx-GND    ON    OFF</p> <p>MIx : External terminal</p>

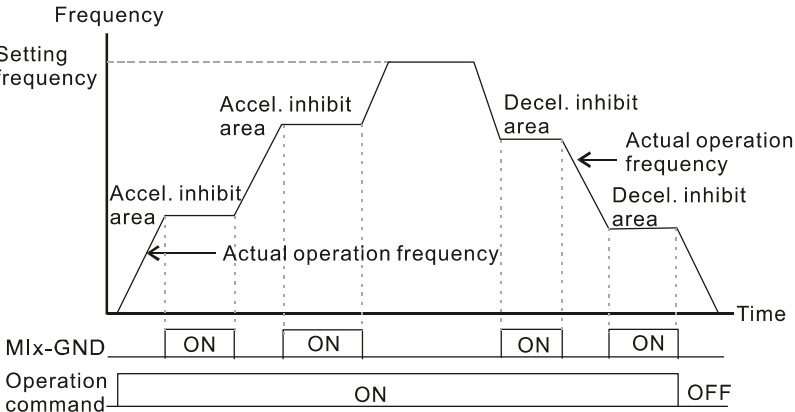
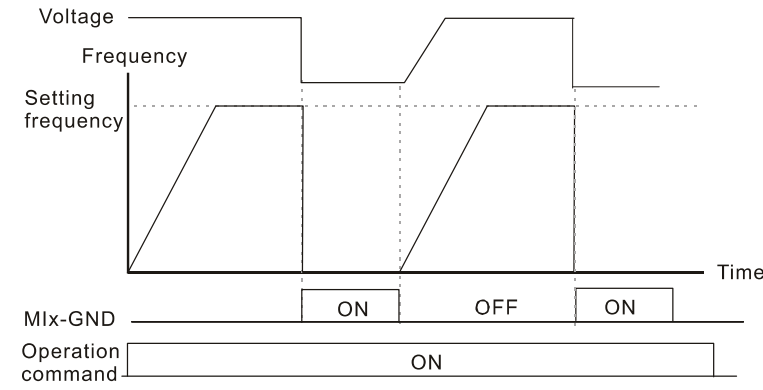

Settings	Functions	Descriptions
7	Acceleration/deceleration Speed Inhibit	<p>When you enable this function, the drive stops acceleration or deceleration immediately. After you disable this function, the AC motor drive starts to accelerate or decelerate from the inhibit point.</p> 
8	The 1 <sup>st</sup> , 2 <sup>nd</sup> acceleration / deceleration time selection	<p>You can select the acceleration and deceleration time of the drive with this function, or from the digital status of the terminals; there are four acceleration and deceleration selections.</p>
9	The 3 <sup>rd</sup> , 4 <sup>th</sup> acceleration / deceleration time selection	
10	EF Input (EF: External Fault)	<p>For external fault input. The drive decelerates according to the Pr.07-20 setting, and the keypad shows "EF" (it shows the fault record when an external fault occurs). The drive keeps running until the fault is cleared (terminal status restored) after RESET.</p>
11	Base block (B.B.) input from external	<p>ON: the output of the drive stops immediately. The motor is in free run and the keypad displays the B.B. signal. Refer to Pr.07-08 for details.</p>
12	Output Stop (Output pause)	<p>When the switch is ON, output of the drive stops immediately and the motor is in free run status. The drive is in output waiting status until the switch is turned to OFF, and then the drive restarts and runs to the current setting frequency.</p> 
13	Cancel the setting of auto-acceleration / auto-deceleration time	<p>Set Pr.01-44 to one of the 01–04 setting modes before using this function. When this function is enabled, OFF is for auto mode and ON is for linear acceleration / deceleration.</p>
14	Switch between motor 1 and motor 2	<p>When the contact of this function is ON: use motor 2 parameters. OFF: use motor 1 parameters.</p>
15	Rotating speed command form AVI	<p>ON: force the source of the frequency to be AVI. If the rotating speed commands are set to AVI, ACI and AUI at the same time, the priority is AVI &gt; ACI &gt; AUI.</p>

Settings	Functions	Descriptions
16	Rotating speed command form ACI	ON: force the source of the frequency to be ACI. If the rotating speed commands are set to AVI, ACI and AVI at the same time, the priority is AVI > ACI.> AUI
17	Rotating speed command form AUI	ON: force the source of the frequency to be AUI. If the rotating speed commands are set to AVI, ACI and AVI at the same time, the priority is AVI > ACI.> AUI
18	Forced to Stop (Pr. 07-20)	ON: the drive ramps to stop according to the Pr.07-20 setting.
19	Digital up command	ON: the frequency of the drive increases or decreases by one unit. If this function remains ON continuously, the frequency increases or decreases according to Pr.02-09 / Pr.02-10.
20	Digital down command	The Frequency command returns to zero when the drive stops, and the displayed frequency is 0.00 Hz. If you select Pr.11-00, bit 7 = 1, the frequency is not saved.
21	PID function disabled	ON: the PID function is disabled.
22	Clear the counter	ON: the current counter value is cleared and displays 0. The drive counts up when this function is disabled.
23	Input the counter value (MI6)	On: the counter value increases by 1. Use the function with Pr.02-19.
24	FWD JOG command	This function is valid when the source of the operation command is external terminal. ON: the drive executes forward JOG. When executing the JOG command in torque mode, the drive automatically switches to speed mode. The drive returns to torque mode after the JOG command is complete.
25	REV JOG command	This function is valid when the source of the operation command is external terminal. ON: the drive executes reverse JOG. When executing the JOG command in torque mode, the drive automatically switches to speed mode. The drive returns to torque mode after the JOG command is complete.
26	TQC / FOC mode selection	<p>ON: TQC mode. OFF: FOC mode.</p> <p>03-00~02=1 (AVI/AUI/ACI is frequency command) 03-00~02=2 (AVI/AUI/ACI is torque command)</p> <p>Control mode</p> <p>Switch timing fro torque/speed control (Pr. 00-10=0/4, multi-function input terminal is set to 26)</p>
27	ASR1/ ASR2 selection	ON: the speed is adjusted by the ASR 2 setting. OFF: the speed is adjusted by the ASR 1 setting. Refer to Pr.11-02 for details.

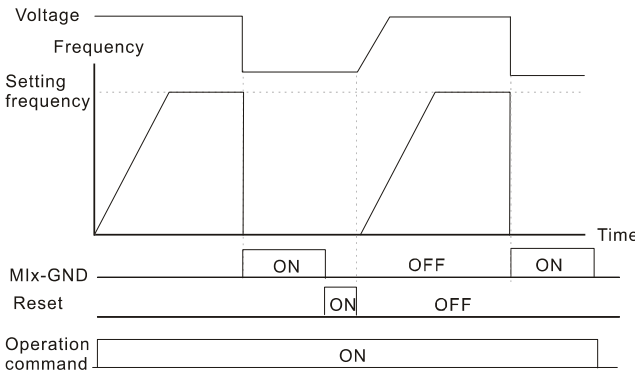
Settings	Functions	Descriptions
28	Emergency stop (EF1)	<p>ON: the output of the drive stops immediately, displays “EF1” on the keypad, and the motor is in free run status. The drive keeps running until the fault is cleared after you press RESET on the keypad (EF: External Fault).</p> 
29	Signal confirmation for Y-connection	When the control mode is V/F, ON: the drive operates by the first V/F.
30	Signal confirmation for Δ-connection	When the control mode is V/F, ON: the drive operates by the second V/F.
31	High torque bias	Refer to Pr. 11-30~Pr. 11-32 for details.
32	Middle torque bias	
33	Low torque bias	
34	Switch between multi-step position and multi-step speed control	

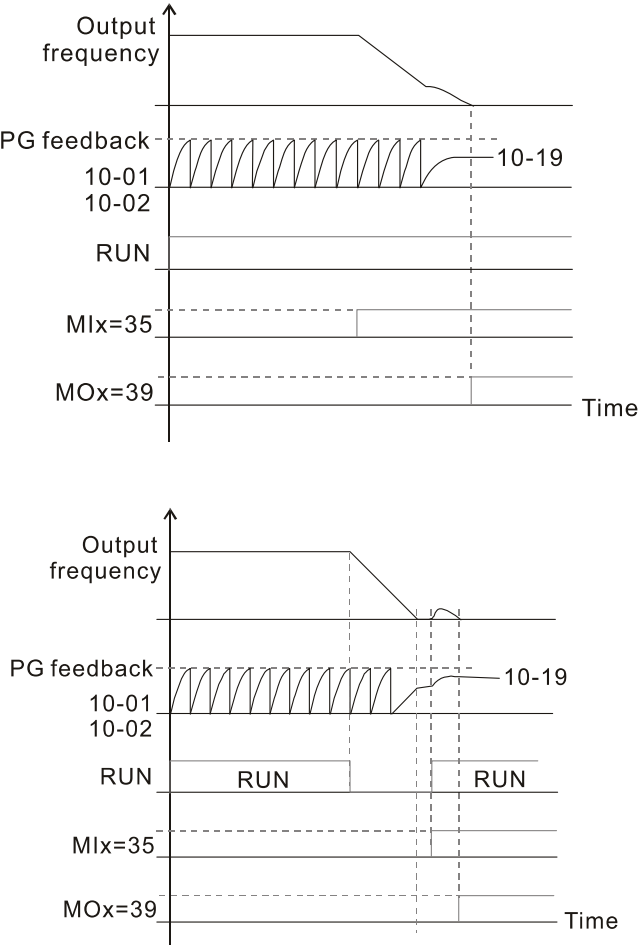
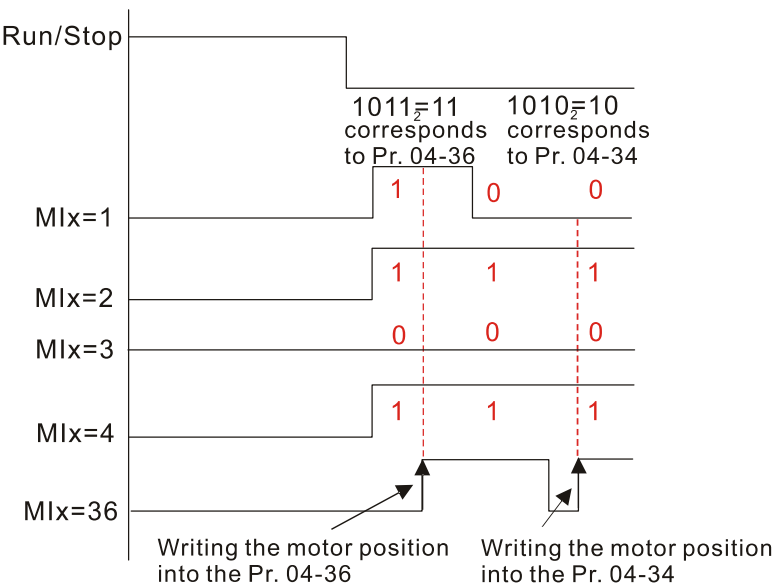
Settings	Functions	Descriptions
35	Enable single-point position control	<p>ON: the AC motor drive executes internal single-point position control according to the setting for Pr.10-19. This function is valid in FOCPG mode only.</p> 
36	Enable multi-step position learning function (valid at stop)	<p>ON/OFF: the drive uses the multi-function inputs 1–4 ON/OFF status to find the corresponding multi-step positions and writes the current motor position into the corresponding multi-step position.</p> 

Settings	Functions	Descriptions															
37	Enable full position control pulse command input	<p>When Pr.00-20 is set to 4 or 5, ON: the input pulse of the PG card is the position command. When using this function, set Pr.11-25 to 0.</p> <p>Example: refer to the following diagram when using this function with Mlx=35 returning to homing position.</p>															
38	Disable write EEPROM function (Parameters memory disable)	ON: writing to EEPROM is disabled. Changed parameters are not saved after power off.															
39	Torque command direction	For torque control (Pr.00-10=2), when the torque command is AVI or ACI, ON: negative torque.															
40	Force coasting to stop	ON: during operation, the drive free runs to stop.															
41	HAND switch	<ol style="list-style-type: none"> <li>When the MI terminal switches to OFF, it executes a STOP command. Therefore, if the MI terminal switches to OFF during operation, the drive stops.</li> <li>Use the optional keypad KPC-CC01 to switch between HAND and AUTO. The drive stops first, and then switches to HAND or AUTO status.</li> </ol>															
42	AUTO switch	<ol style="list-style-type: none"> <li>The optional digital keypad KPC-CC01 displays the current status of the drive (HAND / OFF / AUTO).</li> </ol> <table border="1" style="margin-left: auto; margin-right: auto;"> <thead> <tr> <th></th> <th>bit1</th> <th>bit0</th> </tr> </thead> <tbody> <tr> <td>OFF</td> <td>0</td> <td>0</td> </tr> <tr> <td>AUTO</td> <td>0</td> <td>1</td> </tr> <tr> <td>HAND</td> <td>1</td> <td>0</td> </tr> <tr> <td>OFF</td> <td>1</td> <td>1</td> </tr> </tbody> </table>		bit1	bit0	OFF	0	0	AUTO	0	1	HAND	1	0	OFF	1	1
	bit1	bit0															
OFF	0	0															
AUTO	0	1															
HAND	1	0															
OFF	1	1															
43	Enable resolution selection	Refer to Pr. 02-48 for details.															
44	Reverse direction homing (NL)	<p>Signal input for reverse direction limit switch (NL). ON: the drive uses the settings in Pr.00-40, 00-41, 00-42 to execute homing in a reverse direction (counter-clockwise).</p> <p>Note: NL means the input terminal detection is negative-edge triggered or is regarded as N.O. (Normally Open).</p>															

Settings	Functions	Descriptions															
45	Forward direction homing (PL)	Signal input for forward direction limit switch (PL). ON: the drive uses the settings in Pr.00-40, 00-41, 00-42 to execute homing in a forward direction (clockwise). Note: PL means input terminal detection is positive-edge triggered or is regarded as N.C. (Normally Closed)															
46	Homing (ORG)	ORG point input. ON: the drive uses the setting in Pr.00-40, 00-41, 00-42 to execute homing.															
47	Enable homing function	Pr.00-10=3 (homing mode), if the external terminal MIx=47 is OFF, the drive ignores the HOME command and executes Point-to-Point position control.															
48	Mechanical gear ratio switch	ON: the mechanical gear ratio switches to the second group. Refer to Pr.10-04–Pr.10-07.															
49	Enable drive	When the drive is enabled, the RUN command is valid. When the drive is disabled, the RUN command is invalid. When the drive is operating, the motor coasts to stop. This function varies with MOx=45.															
50	Slave dEb action to execute	Slave receives dEb message from Master, avoids low voltage of DC BUS, and coast to stop because of Lv error.															
51	Selection for PLC mode bit0	<table border="1"> <thead> <tr> <th>PLC status</th> <th>bit1</th> <th>bit0</th> </tr> </thead> <tbody> <tr> <td>Disable PLC function (PLC 0)</td> <td>0</td> <td>0</td> </tr> <tr> <td>Trigger PLC to operation (PLC 1)</td> <td>0</td> <td>1</td> </tr> <tr> <td>Trigger PLC to stop (PLC 2)</td> <td>1</td> <td>0</td> </tr> <tr> <td>No function</td> <td>1</td> <td>1</td> </tr> </tbody> </table>	PLC status	bit1	bit0	Disable PLC function (PLC 0)	0	0	Trigger PLC to operation (PLC 1)	0	1	Trigger PLC to stop (PLC 2)	1	0	No function	1	1
PLC status	bit1		bit0														
Disable PLC function (PLC 0)	0		0														
Trigger PLC to operation (PLC 1)	0		1														
Trigger PLC to stop (PLC 2)	1	0															
No function	1	1															
52	Selection for PLC mode bit1																
53	Trigger CANopen quick stop	When this function is enabled under CANopen control, it will change to quick stop. Refer to Chapter 15 CANopen overview for more details.															
55	Brake release	This parameter needs to be used with Pr. 02-56. The main purpose is to make sure if mechanical brake works or not after triggering brake release command. If the action is right, mechanical brake will give signal to MI terminal. Please check time sequence chart for reference.															
56	Local / Remote Selection	Use Pr. 00-29 to select for LOCAL/ REMOTE mode (refer to Pr. 00-29). When Pr. 00-29 is not set to 0, on the digital keypad KPC-CC01 it will display LOC/ REM status. (It will display on the KPC-CC01 if the firmware version is above version 1.021). <table border="1"> <thead> <tr> <th></th> <th>bit0</th> </tr> </thead> <tbody> <tr> <td>REM</td> <td>0</td> </tr> <tr> <td>LOC</td> <td>1</td> </tr> </tbody> </table>		bit0	REM	0	LOC	1									
	bit0																
REM	0																
LOC	1																

### 02-09 UP/DOWN Key Mode

Default: 0

Settings 0: UP / DOWN by acceleration / deceleration time  
1: UP / DOWN constant speed (Pr. 02-10)

### 02-10 Constant speed. The Accel. / Decel. Speed of the UP/ DOWN Key

Default: 0.001

Settings 0.001~1.000Hz/ms

 Use when the multi-function input terminals are set to 19, 20 (UP / DOWN command). The frequency increases or decreases according to Pr.02-09 and Pr.02-10.

- When Pr.11-00 bit 7=1, the frequency is not saved. The Frequency command returns to zero when the drive stops, and the displayed frequency is 0.00 Hz. At this time, the increasing or decreasing frequency command (F) by using the UP or DOWN key is valid only when the drive is running.
- When Pr.02-09 is set to 0: the increasing or decreasing frequency command (F) operates according to the setting for acceleration or deceleration time (refer to Pr.01-12-01-19).

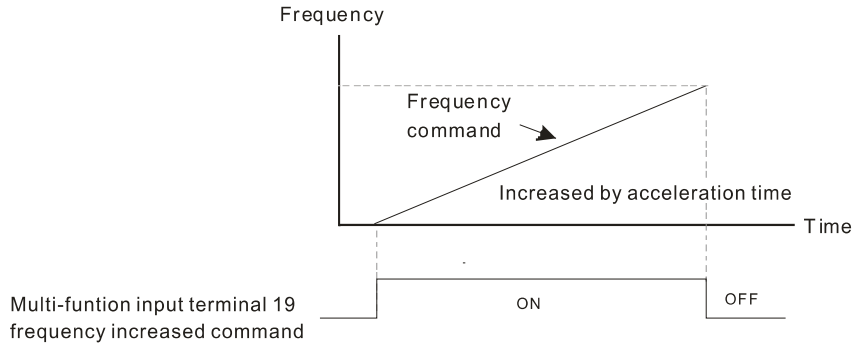

- When Pr.02-09 is set to 1: the increasing / decreasing frequency command (F) operates according to the setting of Pr.02-10 (0.01–1.00 Hz/ms).

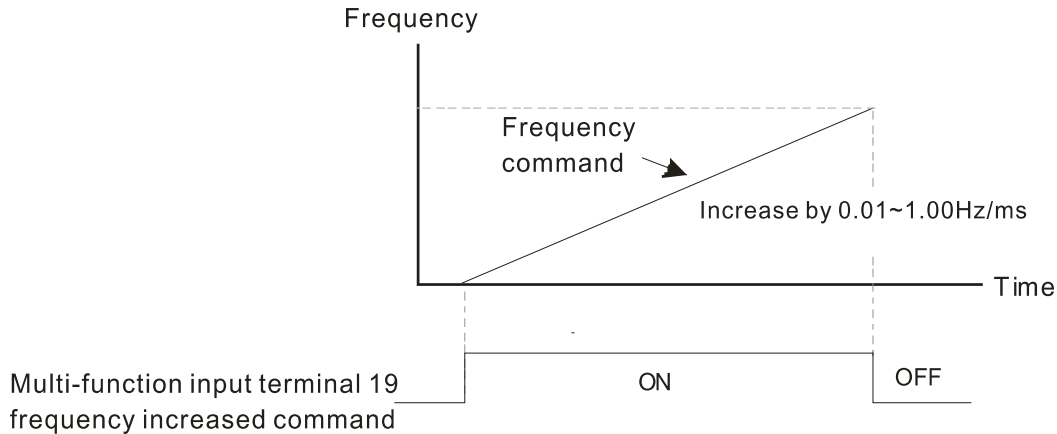

**02-11** Digital Input Response Time Default: 0.005

Settings 0.000~30.000 sec.

- Use this parameter to set the response time of the digital input terminals FWD, REV, and MI1–MI8.
- This function is to delay and confirm the digital input terminal signal. The time for delay is also the time for confirmation. The confirmation prevents interference that could cause error in the input to the digital terminals. But in the meanwhile, it delays the response time though confirmation improves accuracy.
- When using MI8 as encoder pulse feedback input, this parameter will not be referred.

**02-12** Digital Input Operation Setting Default: 0000h

Settings 0000h~FFFFh (0: N.O. ; 1: N.C.)

- The setting of this parameter is in hexadecimal.
- This parameter sets the status of the multi-function input signal (0: normally open; 1: normally closed) and it is not affected by the status of SINK / SOURCE.
- bit2–bit15 correspond to MI1–MI14

 The default for bit 0 (MI1) is FWD terminal, and the default for bit 1 (MI2) is REV terminal. You cannot use this parameter to change the input mode when Pr.02-00 ≠ 0.

 You can change the terminal ON / OFF status through communications.

For example: MI1 is set to 1 (multi-step speed command 1) and MI2 is set to 2 (multi-step speed command 2). Then the forward + second step speed command =  $1001_2 = 9_{10}$ .

As long as Pr.02-12 = 9 is set through communications, there is no need to wire any multi-function terminal to run forward with the second step speed.

bit15	bit14	bit13	bit12	bit11	bit10	bit9	bit8	bit7	bit6	bit5	bit4	bit3	bit2	bit1	bit0
MI14	MI13	MI12	MI11	MI10	MI9	MI8	MI7	MI6	MI5	MI4	MI3	MI2	MI1	X	X

 Use Pr.11-42 bit 1 to select whether the FWD / REV terminal is controlled by Pr.02-12 bit 0 and bit 1.

- ↗
02-13
 Multi-function Output 1 (Relay1) Default: 11
- ↗
02-14
 Multi-function Output 2 (Relay2) Default: 1
- ↗
02-16
 Multi-function Output 3 (MO1) Default: 66
- ↗
02-17
 Multi-function Output 4 (MO2)
- ↗
02-36
 Output terminal of I/O extension card (MO10) or (RA10)
- ↗
02-37
 Output terminal of I/O extension card (MO11) or (RA11)
- ↗
02-38
 Output terminal of I/O extension card (RA12)
- ↗
02-39
 Output terminal of I/O extension card (RA13)
- ↗
02-40
 Output terminal of I/O extension card (RA14)
- ↗
02-41
 Output terminal of I/O extension card (RA15)
- ↗
02-42
 Output terminal of I/O extension card (MO16 virtual terminal)
- ↗
02-43
 Output terminal of I/O extension card (MO17 virtual terminal)
- ↗
02-44
 Output terminal of I/O extension card (MO18 virtual terminal)
- ↗
02-45
 Output terminal of I/O extension card (MO19 virtual terminal)
- ↗
02-46
 Output terminal of I/O extension card (MO20 virtual terminal) Default: 0

#### Settings

0: No function

1: Indication during RUN

2: Operation speed reached

3: Desired frequency reached 1 (Pr. 02-22)

4: Desired frequency reached 2 (Pr. 02-24)

5: Zero speed (Frequency command)

6: zero speed including STOP (Frequency command)

7: Over-torque 1 (Pr. 06-06–06-08)

8: Over-torque 2 (Pr. 06-09–06-11)

9: Drive is ready



- 10: Low voltage warning (Lv) (Pr. 06-00)
- 11: Malfunction indication
- 12: Mechanical brake release (Pr. 02-32)
- 13: Over-heat warning (Pr. 06-15)
- 14: Software brake signal indication (Pr. 07-00)
- 15: PID feedback error (Pr.08-13, 08-14)
- 16: Slip error (oSL)
- 17: Count value reached, does not return to 0 (Pr. 02-20)
- 18: Count value reached, returns to 0 (Pr. 02-19)
- 19: External interrupt B.B. input (Base Block)
- 20: Warning output
- 21: Over-voltage
- 22: Over-current stall prevention
- 23: Over-voltage stall prevention
- 24: Operation mode
- 25: Forward command
- 26: Reverse command
- 27: Output when current  $\geq$  Pr. 02-33
- 28: Output when current  $<$  Pr. 02-33
- 29: Output when frequency  $\geq$  Pr. 02-34
- 30: Output when frequency  $<$  Pr. 02-34
- 31: Y-connection for the motor coil
- 32:  $\Delta$  -connection for the motor coil
- 33: Zero speed (actual output frequency)
- 34: Zero speed including stop (actual output frequency)
- 35: Error output selection 1 (Pr. 06-23)
- 36: Error output selection 2 (Pr. 06-24)
- 37: Error output selection 3 (Pr. 06-25)
- 38: Error output selection 4 (Pr. 06-26)
- 39: Position reached (Pr. 10-19)
- 40: Speed reached (including Stop)
- 41: Multi-position reached
- 42: Crane function
- 43: Actual motor speed higher than Pr. 02-47
- 44: Low current output (use with Pr. 06-71~Pr. 06-73)
- 45: UVW output electromagnetic valve switch
- 46: Master dEb output
- 47: Closed brake output
- 49: Homing action complete output
- 50: Output control for CANopen
- 51: Analog output control for RS-485 (InnerCOM / MODBUS)
- 52: Output control for communication cards

65: Output for CANopen and RS-485

66: SO output logic A

67: Analog input signal level reached

68: SO output logic B

70: FAN warning detection output

 Use this parameter to set the function of the multi-function terminals.

 Pr. 02-36~Pr. 02-41 requires additional extension cards to display the parameters, the choices of optional cards are EMC-D42A and EMC-R6AA.

 The optional card EMC-D42A provides 2 output terminals and can be used with Pr. 02-36~02-37.

 The optional card EMC-R6AA provides 6 output terminals and can be used with Pr. 02-36~02-41.

#### Summary of function settings

Take the normally open contact (N.O.) for example, ON: contact is closed, OFF: contact is open

Settings	Functions	Descriptions
0	No Function	Output terminal with no function
1	Indication during RUN	Active when the drive is not in STOP.
2	Operation speed reached	Active when output frequency of the drive reaches the setting frequency.
3	Desired Frequency reached 1 (Pr. 02-22)	Active when the desired frequency (Pr. 02-22) is reached
4	Desired Frequency reached 2 (Pr. 02-24)	Active when the desired frequency (Pr. 02-24) is reached.
5	Zero Speed (frequency command)	Active when frequency command =0. (the drive must be at RUN status)
6	zero speed including STOP (Frequency command)	Active when frequency command =0 or stopped.
7	Over-torque 1	Active when the drive detects over-torque. Pr.06-07 sets the over-torque detection level (motor 1), and Pr.06-08 sets the over-torque detection time (motor 1). Refer to Pr.06-06–06-08.
8	Over-torque 2	Active when the drive detects over-torque. Pr.06-10 sets the over-torque detection level (motor 2), and Pr.06-11 sets the over-torque detection time (motor 2). Refer to Pr.06-09–06-11.
9	Drive is Ready	Active when the drive is ON and with no error detected.
10	Low voltage warning (Lv)	Active when the DC BUS voltage is too low. (refer to Pr. 06-00 low voltage level)
11	Malfunction Indication	Active when fault occurs (except Lv stop).
12	Mechanical Brake Release (Pr. 02-32)	When drive runs after Pr. 02-32, it will be ON. This function should be used with DC brake and it is recommended to use contact “b” (N.C.).
13	Over-heat warning	Active when IGBT or heat sink overheats; to prevent the drive from shutting down due to over-heating (refer to Pr.06-15).
14	Software Brake Signal Indication	Active when the soft brake function is ON. (refer to Pr. 07-00)
15	PID Feedback Error	Active when the PID feedback signal error is detected.
16	Slip Error (oS�)	Active when the slip error is detected.
17	Count value reached, does not return to 0 (Pr. 02-20)	When the drive executes external counter, this contact is active if the count value is equal to the setting value for Pr.02-20. This contact is not active when the setting value for Pr.02-20 > Pr.02-19.

Settings	Functions	Descriptions
18	Count value reached, returns to 0 (Pr. 02-19)	When the drive executes the external counter, this contact is active if the count value is equal to the setting value for Pr.02-19.
19	External interrupt B.B. input (Base Block)	Active when external interrupt (B.B.) stop output occurs in the drive.
20	Warning Output	Active when the warning is detected.
21	Over-voltage	Active when the over-voltage is detected.
22	Over-current Stall Prevention	Active when the over-current stall prevention is detected.
23	Over-voltage Stall prevention	Active when the over-voltage stall prevention is detected.
24	Operation Mode	Active when the operation command is controlled by external terminal. (Pr. 00-21≠0)
25	Forward Command	Active when the operation direction is forward.
26	Reverse Command	Active when the operation direction is reverse.
27	Output when Current $\geq$ Pr. 02-33	Active when current is $\geq$ Pr. 02-33.
28	Output when Current $<$ Pr. 02-33	Active when current is $<$ Pr. 02-33
29	Output when frequency $\geq$ Pr. 02-34	Active when frequency is $\geq$ Pr. 02-34.
30	Output when Frequency $<$ Pr. 02-34	Active when frequency is $<$ Pr. 02-34.
31	Y-connection for the Motor Coil	Active when Pr. 05-24=1, when frequency output is lower than Pr. 05-23 minus 2Hz, and lasts longer than Pr. 05-25.
32	$\Delta$ -connection for the Motor Coil	Active when Pr. 05-24=1, when frequency output is higher than Pr. 05-23 plus 2Hz, and lasts longer than Pr. 05-25.
33	Zero Speed (actual output frequency)	Active when the actual output frequency is 0. (the drive is in RUN mode)
34	Zero speed including stop (actual output frequency)	Active when the actual output frequency is 0 or stopped.
35	Error Output Selection 1 (Pr. 06-23)	Active when Pr. 06-23 is ON.
36	Error Output Selection 2 (Pr. 06-24)	Active when Pr. 06-24 is ON.
37	Error Output Selection 3 (Pr. 06-25)	Active when Pr. 06-25 is ON.
38	Error Output Selection 4 (Pr. 06-26)	Active when Pr. 06-26 is ON.
39	Position reached (Pr. 10-19)	Active when the PG position control point reaches Pr. 10-19.
40	Speed reached (including speed)	Active when the output frequency reaches frequency setting or stop.

Settings	Functions	Descriptions																																																																																
41	Multi-position reached	<p>User can set any three multi-function input terminals to 41. The current position action status of these three terminals will be outputted. Example: if setting Pr. 02-36~02-38 to 41 and only the multi-position of the second point has been done. Then, the current status is RA (ON), RA (OFF) and MO1 (OFF). In this way, their status is 010. bit0 is RA and so on.</p> <table border="1"> <thead> <tr> <th></th> <th>MO2 Pr.02-17=41</th> <th>MO1 Pr.02-16=41</th> <th>RY2 Pr.02-14=41</th> <th>RY1 Pr.02-13=41</th> </tr> </thead> <tbody> <tr><td>Pr. 04-16</td><td>0</td><td>0</td><td>0</td><td>1</td></tr> <tr><td>Pr. 04-18</td><td>0</td><td>0</td><td>1</td><td>0</td></tr> <tr><td>Pr. 04-20</td><td>0</td><td>0</td><td>1</td><td>1</td></tr> <tr><td>Pr. 04-22</td><td>0</td><td>1</td><td>0</td><td>0</td></tr> <tr><td>Pr. 04-24</td><td>0</td><td>1</td><td>0</td><td>1</td></tr> <tr><td>Pr. 04-26</td><td>0</td><td>1</td><td>1</td><td>0</td></tr> <tr><td>Pr. 04-28</td><td>0</td><td>1</td><td>1</td><td>1</td></tr> <tr><td>Pr. 04-30</td><td>1</td><td>0</td><td>0</td><td>0</td></tr> <tr><td>Pr. 04-32</td><td>1</td><td>0</td><td>0</td><td>1</td></tr> <tr><td>Pr. 04-34</td><td>1</td><td>0</td><td>1</td><td>0</td></tr> <tr><td>Pr. 04-36</td><td>1</td><td>0</td><td>1</td><td>1</td></tr> <tr><td>Pr. 04-38</td><td>1</td><td>1</td><td>0</td><td>0</td></tr> <tr><td>Pr. 04-40</td><td>1</td><td>1</td><td>0</td><td>1</td></tr> <tr><td>Pr. 04-42</td><td>1</td><td>1</td><td>1</td><td>0</td></tr> <tr><td>Pr. 04-44</td><td>1</td><td>1</td><td>1</td><td>1</td></tr> </tbody> </table>		MO2 Pr.02-17=41	MO1 Pr.02-16=41	RY2 Pr.02-14=41	RY1 Pr.02-13=41	Pr. 04-16	0	0	0	1	Pr. 04-18	0	0	1	0	Pr. 04-20	0	0	1	1	Pr. 04-22	0	1	0	0	Pr. 04-24	0	1	0	1	Pr. 04-26	0	1	1	0	Pr. 04-28	0	1	1	1	Pr. 04-30	1	0	0	0	Pr. 04-32	1	0	0	1	Pr. 04-34	1	0	1	0	Pr. 04-36	1	0	1	1	Pr. 04-38	1	1	0	0	Pr. 04-40	1	1	0	1	Pr. 04-42	1	1	1	0	Pr. 04-44	1	1	1	1
	MO2 Pr.02-17=41	MO1 Pr.02-16=41	RY2 Pr.02-14=41	RY1 Pr.02-13=41																																																																														
Pr. 04-16	0	0	0	1																																																																														
Pr. 04-18	0	0	1	0																																																																														
Pr. 04-20	0	0	1	1																																																																														
Pr. 04-22	0	1	0	0																																																																														
Pr. 04-24	0	1	0	1																																																																														
Pr. 04-26	0	1	1	0																																																																														
Pr. 04-28	0	1	1	1																																																																														
Pr. 04-30	1	0	0	0																																																																														
Pr. 04-32	1	0	0	1																																																																														
Pr. 04-34	1	0	1	0																																																																														
Pr. 04-36	1	0	1	1																																																																														
Pr. 04-38	1	1	0	0																																																																														
Pr. 04-40	1	1	0	1																																																																														
Pr. 04-42	1	1	1	0																																																																														
Pr. 04-44	1	1	1	1																																																																														
42	Crane Function	<p>Use this function with Pr. 02-32, Pr. 02-33, Pr. 02-34, Pr. 02-57 and Pr. 02-58. The example of the crane application is in the following for your reference.</p>																																																																																
43	Actual motor speed higher than Pr. 02-47	Active when motor actual speed is higher than Pr. 02-47.																																																																																
44	Low Current Output	Use this function with Pr. 06-71–Pr. 06-73																																																																																
45	UVW output electromagnetic valve switch	<p>Use this function with external terminal input = 49 (drive enabled) and external terminal output = 45 (electromagnetic valve enabled), and then the electromagnetic valve is ON or OFF according to the status of the drive.</p> <p>The diagram consists of two parts. The top part is a timing diagram with two horizontal axes: 'Enable' and 'Contactor'. The 'Enable' signal is a trapezoidal pulse that rises and then falls. The 'Contactor' signal is a rectangular pulse that is high during the entire duration of the 'Enable' signal. The bottom part is a circuit diagram. On the left is an 'AC Drive' with three output terminals labeled 'U/T1', 'V/T2', and 'W/T3'. These terminals are connected to a three-phase 'Motor' (IM 3~). A 'MC' (Magnetic Contactor) is connected in series between the AC Drive and the Motor. The MC has three contacts. The control circuit for the MC includes a terminal 'MOx=45' which is connected to the top contact of the MC. Another terminal 'MIx=49' is connected to the bottom contact of the MC.</p>																																																																																

Settings	Functions	Descriptions																																																
46	Master dEb output	When dEb rises at the master, MO sends a dEb signal to the slave. Output the message when the master triggers dEb. This ensures that the slave also triggers dEb. Then slave follows the deceleration time of the master to stop simultaneously with the master.																																																
47	Closed brake output	<p>When drive stops, the corresponding multi-function terminal will be ON if the frequency is less than Pr. 02-34. After it is ON, it will be OFF when brake delay time exceeds Pr. 02-32.</p>																																																
49	Homing Action Complete output	Output when homing action is complete.																																																
50	Output control for CANopen	<p>Control multi-function output terminals through CANopen. To control RY2, set Pr. 02-14 = 50. The mapping table of the CANopen DO is below:</p> <table border="1"> <thead> <tr> <th>Physical terminal</th> <th>Setting of related parameters</th> <th>Attribute</th> <th>Corresponding Index</th> </tr> </thead> <tbody> <tr> <td>RY1</td> <td>Pr. 02-13 = 50</td> <td>RW</td> <td>The bit0 at 2026-41</td> </tr> <tr> <td>RY2</td> <td>Pr. 02-14 = 50</td> <td>RW</td> <td>The bit1 at 2026-41</td> </tr> <tr> <td>MO1</td> <td>Pr. 02-16 = 50</td> <td>RW</td> <td>The bit3 at 2026-41</td> </tr> <tr> <td>MO2</td> <td>Pr. 02-17 = 50</td> <td>RW</td> <td>The bit4 at 2026-41</td> </tr> <tr> <td>MO10</td> <td rowspan="2">Pr. 02-36 = 50</td> <td rowspan="2">RW</td> <td>The bit5 at 2026-41</td> </tr> <tr> <td>RY10</td> <td>The bit5 at 2026-41</td> </tr> <tr> <td>MO11</td> <td rowspan="2">Pr. 02-37 = 50</td> <td rowspan="2">RW</td> <td>The bit6 at 2026-41</td> </tr> <tr> <td>RY11</td> <td>The bit6 at 2026-41</td> </tr> <tr> <td>RY12</td> <td>Pr. 02-38 = 50</td> <td>RW</td> <td>The bit7 at 2026-41</td> </tr> <tr> <td>RY13</td> <td>Pr. 02-39 = 50</td> <td>RW</td> <td>The bit8 at 2026-41</td> </tr> <tr> <td>RY14</td> <td>Pr. 02-40 = 50</td> <td>RW</td> <td>The bit9 at 2026-41</td> </tr> <tr> <td>RY15</td> <td>Pr. 02-41 = 50</td> <td>RW</td> <td>The bit10 at 2026-41</td> </tr> </tbody> </table> <p>Refer to section 15-3-5 for more information.</p>	Physical terminal	Setting of related parameters	Attribute	Corresponding Index	RY1	Pr. 02-13 = 50	RW	The bit0 at 2026-41	RY2	Pr. 02-14 = 50	RW	The bit1 at 2026-41	MO1	Pr. 02-16 = 50	RW	The bit3 at 2026-41	MO2	Pr. 02-17 = 50	RW	The bit4 at 2026-41	MO10	Pr. 02-36 = 50	RW	The bit5 at 2026-41	RY10	The bit5 at 2026-41	MO11	Pr. 02-37 = 50	RW	The bit6 at 2026-41	RY11	The bit6 at 2026-41	RY12	Pr. 02-38 = 50	RW	The bit7 at 2026-41	RY13	Pr. 02-39 = 50	RW	The bit8 at 2026-41	RY14	Pr. 02-40 = 50	RW	The bit9 at 2026-41	RY15	Pr. 02-41 = 50	RW	The bit10 at 2026-41
Physical terminal	Setting of related parameters	Attribute	Corresponding Index																																															
RY1	Pr. 02-13 = 50	RW	The bit0 at 2026-41																																															
RY2	Pr. 02-14 = 50	RW	The bit1 at 2026-41																																															
MO1	Pr. 02-16 = 50	RW	The bit3 at 2026-41																																															
MO2	Pr. 02-17 = 50	RW	The bit4 at 2026-41																																															
MO10	Pr. 02-36 = 50	RW	The bit5 at 2026-41																																															
RY10			The bit5 at 2026-41																																															
MO11	Pr. 02-37 = 50	RW	The bit6 at 2026-41																																															
RY11			The bit6 at 2026-41																																															
RY12	Pr. 02-38 = 50	RW	The bit7 at 2026-41																																															
RY13	Pr. 02-39 = 50	RW	The bit8 at 2026-41																																															
RY14	Pr. 02-40 = 50	RW	The bit9 at 2026-41																																															
RY15	Pr. 02-41 = 50	RW	The bit10 at 2026-41																																															

Settings	Functions	Descriptions																																												
51	Analog output control for RS-485 (InnerCOM / MODBUS)	For RS-485 interface (InnerCOM/ MODBUS) output.																																												
		<table border="1"> <thead> <tr> <th>Physical terminal</th> <th>Setting of related parameters</th> <th>Attribute</th> <th>Corresponding Index</th> </tr> </thead> <tbody> <tr> <td>RY1</td> <td>Pr. 02-13 = 51</td> <td>RW</td> <td>bit0 at 2640H</td> </tr> <tr> <td>RY2</td> <td>Pr. 02-14 = 51</td> <td>RW</td> <td>bit1 at 2640H</td> </tr> <tr> <td>MO1</td> <td>Pr. 02-16 = 51</td> <td>RW</td> <td>bit3 at 2640H</td> </tr> <tr> <td>MO2</td> <td>Pr. 02-17 = 51</td> <td>RW</td> <td>bit4 at 2640H</td> </tr> <tr> <td>MO10 or RA10</td> <td>Pr. 02-36 = 51</td> <td>RW</td> <td>bit5 at 2640H</td> </tr> <tr> <td>MO11 or RA11</td> <td>Pr. 02-37 = 51</td> <td>RW</td> <td>bit6 at 2640H</td> </tr> <tr> <td>RA12</td> <td>Pr. 02-38 = 51</td> <td>RW</td> <td>bit7 at 2640H</td> </tr> <tr> <td>RA13</td> <td>Pr. 02-39 = 51</td> <td>RW</td> <td>bit8 at 2640H</td> </tr> <tr> <td>RA14</td> <td>Pr. 02-40 = 51</td> <td>RW</td> <td>bit9 at 2640H</td> </tr> <tr> <td>RA15</td> <td>Pr. 02-41 = 51</td> <td>RW</td> <td>bit10 at 2640H</td> </tr> </tbody> </table>	Physical terminal	Setting of related parameters	Attribute	Corresponding Index	RY1	Pr. 02-13 = 51	RW	bit0 at 2640H	RY2	Pr. 02-14 = 51	RW	bit1 at 2640H	MO1	Pr. 02-16 = 51	RW	bit3 at 2640H	MO2	Pr. 02-17 = 51	RW	bit4 at 2640H	MO10 or RA10	Pr. 02-36 = 51	RW	bit5 at 2640H	MO11 or RA11	Pr. 02-37 = 51	RW	bit6 at 2640H	RA12	Pr. 02-38 = 51	RW	bit7 at 2640H	RA13	Pr. 02-39 = 51	RW	bit8 at 2640H	RA14	Pr. 02-40 = 51	RW	bit9 at 2640H	RA15	Pr. 02-41 = 51	RW	bit10 at 2640H
		Physical terminal	Setting of related parameters	Attribute	Corresponding Index																																									
		RY1	Pr. 02-13 = 51	RW	bit0 at 2640H																																									
		RY2	Pr. 02-14 = 51	RW	bit1 at 2640H																																									
		MO1	Pr. 02-16 = 51	RW	bit3 at 2640H																																									
		MO2	Pr. 02-17 = 51	RW	bit4 at 2640H																																									
		MO10 or RA10	Pr. 02-36 = 51	RW	bit5 at 2640H																																									
		MO11 or RA11	Pr. 02-37 = 51	RW	bit6 at 2640H																																									
		RA12	Pr. 02-38 = 51	RW	bit7 at 2640H																																									
RA13	Pr. 02-39 = 51	RW	bit8 at 2640H																																											
RA14	Pr. 02-40 = 51	RW	bit9 at 2640H																																											
RA15	Pr. 02-41 = 51	RW	bit10 at 2640H																																											
52	Output control for communication cards	For communication output of communication cards (CMC-MOD01, CMC-EIP01, CMC-PN01 and CMC-DN01)																																												
		<table border="1"> <thead> <tr> <th>Physical terminal</th> <th>Setting of related parameters</th> <th>Attribute</th> <th>Corresponding Address</th> </tr> </thead> <tbody> <tr> <td>RY1</td> <td>Pr. 02-13 = 52</td> <td>RW</td> <td>The bit0 of 2640H</td> </tr> <tr> <td>RY2</td> <td>Pr. 02-14 = 52</td> <td>RW</td> <td>The bit1 of 2640H</td> </tr> <tr> <td>MO1</td> <td>Pr. 02-16 = 52</td> <td>RW</td> <td>The bit3 of 2640H</td> </tr> <tr> <td>MO2</td> <td>Pr. 02-17 = 52</td> <td>RW</td> <td>The bit4 of 2640H</td> </tr> <tr> <td>MO10 or RA10</td> <td>Pr. 02-36 = 51</td> <td>RW</td> <td>The bit5 of 2640H</td> </tr> <tr> <td>MO11 or RA11</td> <td>Pr. 02-37 = 51</td> <td>RW</td> <td>The bit6 of 2640H</td> </tr> <tr> <td>RA12</td> <td>Pr. 02-38 = 51</td> <td>RW</td> <td>The bit7 of 2640H</td> </tr> <tr> <td>RA13</td> <td>Pr. 02-39 = 51</td> <td>RW</td> <td>The bit8 of 2640H</td> </tr> <tr> <td>RA14</td> <td>Pr. 02-40 = 51</td> <td>RW</td> <td>The bit9 of 2640H</td> </tr> <tr> <td>RA15</td> <td>Pr. 02-41 = 51</td> <td>RW</td> <td>The bit10 of 2640H</td> </tr> </tbody> </table>	Physical terminal	Setting of related parameters	Attribute	Corresponding Address	RY1	Pr. 02-13 = 52	RW	The bit0 of 2640H	RY2	Pr. 02-14 = 52	RW	The bit1 of 2640H	MO1	Pr. 02-16 = 52	RW	The bit3 of 2640H	MO2	Pr. 02-17 = 52	RW	The bit4 of 2640H	MO10 or RA10	Pr. 02-36 = 51	RW	The bit5 of 2640H	MO11 or RA11	Pr. 02-37 = 51	RW	The bit6 of 2640H	RA12	Pr. 02-38 = 51	RW	The bit7 of 2640H	RA13	Pr. 02-39 = 51	RW	The bit8 of 2640H	RA14	Pr. 02-40 = 51	RW	The bit9 of 2640H	RA15	Pr. 02-41 = 51	RW	The bit10 of 2640H
		Physical terminal	Setting of related parameters	Attribute	Corresponding Address																																									
		RY1	Pr. 02-13 = 52	RW	The bit0 of 2640H																																									
		RY2	Pr. 02-14 = 52	RW	The bit1 of 2640H																																									
		MO1	Pr. 02-16 = 52	RW	The bit3 of 2640H																																									
		MO2	Pr. 02-17 = 52	RW	The bit4 of 2640H																																									
		MO10 or RA10	Pr. 02-36 = 51	RW	The bit5 of 2640H																																									
		MO11 or RA11	Pr. 02-37 = 51	RW	The bit6 of 2640H																																									
		RA12	Pr. 02-38 = 51	RW	The bit7 of 2640H																																									
RA13	Pr. 02-39 = 51	RW	The bit8 of 2640H																																											
RA14	Pr. 02-40 = 51	RW	The bit9 of 2640H																																											
RA15	Pr. 02-41 = 51	RW	The bit10 of 2640H																																											
65	Output for CANopen and RS-485	To control output of CANopen & RS-485.																																												
66	SO output logic A	<table border="1"> <thead> <tr> <th rowspan="2">Status of drive</th> <th colspan="2">Status of safety output</th> </tr> <tr> <th>N.O. (MOx=66)</th> <th>N.C. (MOx=68)</th> </tr> </thead> <tbody> <tr> <td>Normal</td> <td>Broken circuit (Open)</td> <td>Short circuit (Close)</td> </tr> <tr> <td>STO</td> <td>Short circuit (Close)</td> <td>Broken circuit (Open)</td> </tr> <tr> <td>STL1~STL3</td> <td>Short circuit (Close)</td> <td>Broken circuit (Open)</td> </tr> </tbody> </table>	Status of drive	Status of safety output		N.O. (MOx=66)	N.C. (MOx=68)	Normal	Broken circuit (Open)	Short circuit (Close)	STO	Short circuit (Close)	Broken circuit (Open)	STL1~STL3	Short circuit (Close)	Broken circuit (Open)																														
				Status of drive	Status of safety output																																									
N.O. (MOx=66)	N.C. (MOx=68)																																													
Normal	Broken circuit (Open)	Short circuit (Close)																																												
STO	Short circuit (Close)	Broken circuit (Open)																																												
STL1~STL3	Short circuit (Close)	Broken circuit (Open)																																												
68	SO output logic B																																													
67	Analog input signal level reached	The multi-function output terminals operate when the analog input level is between the high level and the low level. Pr.03-44: Select one of the analog input channels (AVI, ACI) to be compared.																																												

Settings	Functions	Descriptions
		Pr.03-45: The high level for the analog input, default is 50%. Pr.03-46: The low level for the analog input, default is 10%. If analog input > Pr.03-45, the multi-function output terminal operates. If analog input < 03-46, the multi-function output terminal stops output.
70	Fan warning detection output	The terminal works when the internal fan warning activates

Example: Crane Application

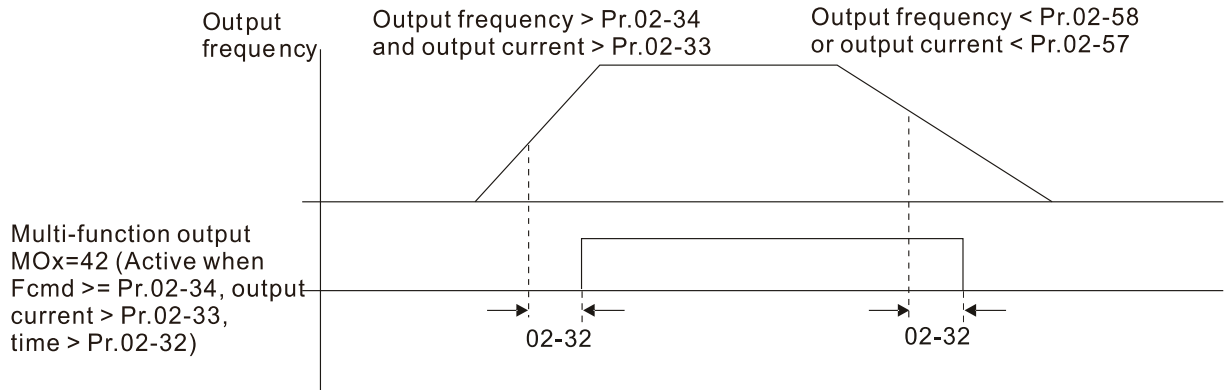

It is recommended to be used with Dwell function as shown in the following:

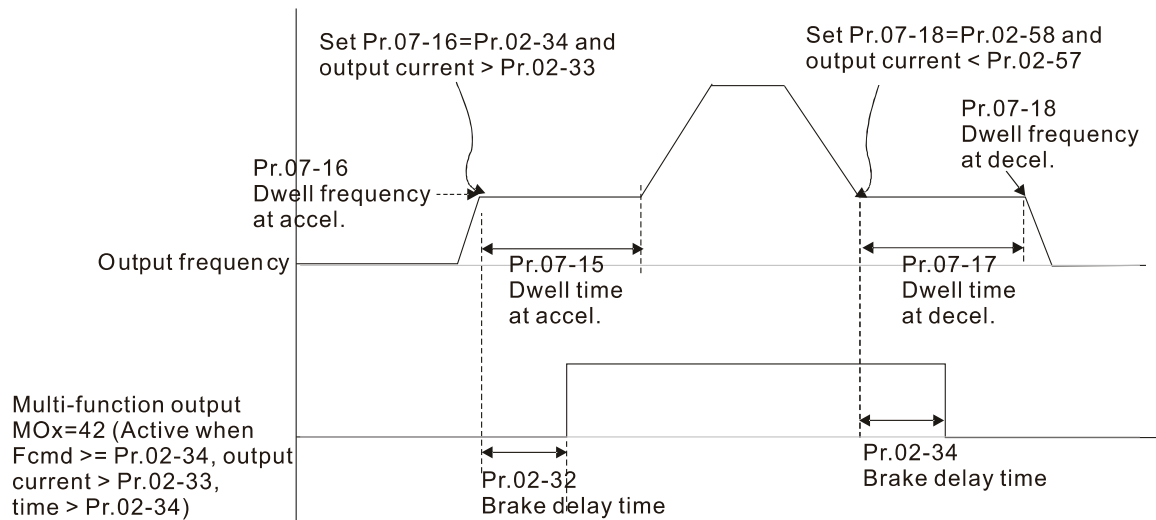

- For crane application, when the MO is set to 42, the setting of Pr. 02-34 must be greater than Pr. 02-58; Pr. 02-33 must be greater than Pr. 02-57.
- To directly control drive's AO/DO and read current AI/DI status via the standard MODBUS, by adding the Remote IO function, the corresponding index of 26xx is as following:

	bit15	bit14	bit13	bit12	bit11	bit10	bit9	bit8	bit7	bit6	bit5	bit4	bit3	bit2	bit1	bit0
2600h	MI15	MI14	MI13	MI12	MI11	MI10	MI8	MI7	MI6	MI5	MI4	MI3	MI2	MI1	REV	FWD
2640h	-	-	-	-	-	MO15	MO14	MO13	MO12	MO11	MO10	MO2	MO1	-	RY2	RY1
2660h	AVI		-	-	-	-	-	-	-	-	-	-	-	-	-	-
2661h	ACI		-	-	-	-	-	-	-	-	-	-	-	-	-	-
2662h	AUI		-	-	-	-	-	-	-	-	-	-	-	-	-	-
266Ah	AI10		-	-	-	-	-	-	-	-	-	-	-	-	-	-
266Bh	AI11		-	-	-	-	-	-	-	-	-	-	-	-	-	-
26A0h	AFM1		-	-	-	-	-	-	-	-	-	-	-	-	-	-
26A1h	AFM2		-	-	-	-	-	-	-	-	-	-	-	-	-	-
26AAh	AO10		-	-	-	-	-	-	-	-	-	-	-	-	-	-
26ABh	AO11		-	-	-	-	-	-	-	-	-	-	-	-	-	-

In addition, the AI and DI value can be read directly, while DO and AO must select MODBUS control under the corresponding parameter function. The related parameter definition is as following:

## DO

Terminal	Pr. Setting	Indexes of MODBUS direct control
RY1	Pr. 02-13 = 51	The bit0 of 2640h
RY2	Pr. 02-14 = 51	The bit1 of 2640h
MO1	Pr. 02-16 = 51	The bit3 of 2640h
MO2	Pr. 02-17 = 51	The bit4 of 2640h
MO10	Pr. 02-36 = 51	The bit5 of 2640h
MO11	Pr. 02-37 = 51	The bit6 of 2640h
MO12	Pr. 02-38 = 51	The bit7 of 2640h
MO13	Pr. 02-39 = 51	The bit8 of 2640h
MO14	Pr. 02-40 = 51	The bit9 of 2640h
MO15	Pr. 02-41 = 51	The bit10 of 2640h

## AO

Terminal	Pr. Setting	Indexes of MODBUS direct control
AFM1	Pr. 03-20=21	The value of 26A0h
AFM2	Pr. 03-23=21	The value of 26A1h
AFM10	Pr. 14-12=21	The value of 26AAh
AFM11	Pr. 14-13=21	The value of 26ABh

### 02-18 Multi-function Output Setting

Default Setting: 0000h

Settings 0000h~FFFFh (0: N.O. ; 1:N.C.)

This parameter is in hexadecimal.

This parameter is set by a bit. If a bit is 1, the corresponding multi-function output acts in an opposite way.

Example:

If Pr. 02-13=1 and Pr. 02-18=0, Relay 1 is ON when the drive runs and is open when the drive is stopped.

If Pr. 02-13=1 and Pr. 02-18=1, Relay 1 is open when the drive runs and is closed when the drive is stopped.

bit setting

bit15	bit14	bit13	bit12	bit11	bit10	bit9	bit8	bit7	bit6	bit5	bit4	bit3	bit2	bit1	bit0
MO20	MO19	MO18	MO17	MO16	MO15	MO14	MO13	MO12	MO11	MO10	MO2	MO1	Reserved	RY2	RY1

### 02-19 Terminal Counting Value Reached (returns to 0)

Default Setting: 0

Settings 0~65500

The counter trigger can be set by the multi-function terminal MI6 (set Pr. 02-06 to 23). Upon completion of counting, the specified multi-function output terminal will be activated (Pr. 02-13, Pr. 02-14, Pr. 02-36, Pr. 02-37 is set to 18). Pr. 02-19 cannot be set to 0.

When the display shows c5555, the drive has counted 5,555 times. If display shows c5555●, it means that real counter value is between 55,550 to 55,559.



**02-20** Preliminary Counting Value Reached (does not return to 0)

Default Setting: 0

Settings 0~65500

When the counter value counts from 1 and reaches this value, the corresponding multi-function output terminal will be activated, provided one of Pr. 02-13, Pr. 02-14, Pr. 02-36, Pr. 02-37 set to 17 (Preliminary Count Value Setting). This parameter can be used for the end of the counting to make the drive runs from the low speed to stop.

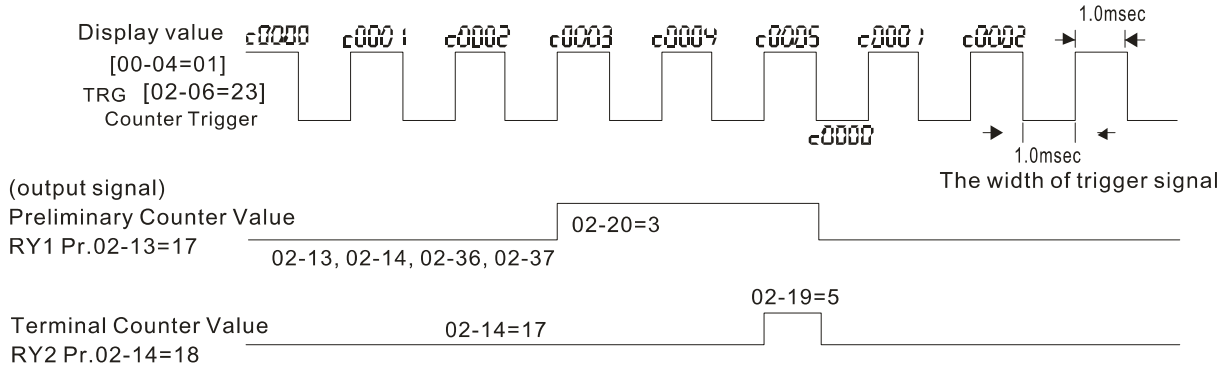

**02-21** Digital Output Gain ( DFM )

Default: 1

Settings 1~166

It is used to set the signal for the digital output terminals (DFM-DCM) and digital frequency output (pulse X work period=50%). Output pulse per second = output frequency X Pr. 02-21.

**02-22** Desired Frequency Reached 1

Default: 60.00/50.00

Settings 0.00~599.00Hz

**02-23** The Width of the Desired Frequency Attained 1

Default: 2.00

Settings 0.00~599.00Hz

**02-24** Desired Frequency Reached 2

Default: 60.00/50.00

Settings 0.00~599.00Hz

**02-25** The Width of the Desired Frequency Reached 2

Default: 2.00

Settings 0.00~599.00Hz

Once output frequency reaches desired frequency and the corresponding multi-function output terminal is set to 3 or 4 (Pr. 02-13, Pr. 02-14, Pr. 02-36 and Pr. 02-37), this multi-function output terminal will be ON.

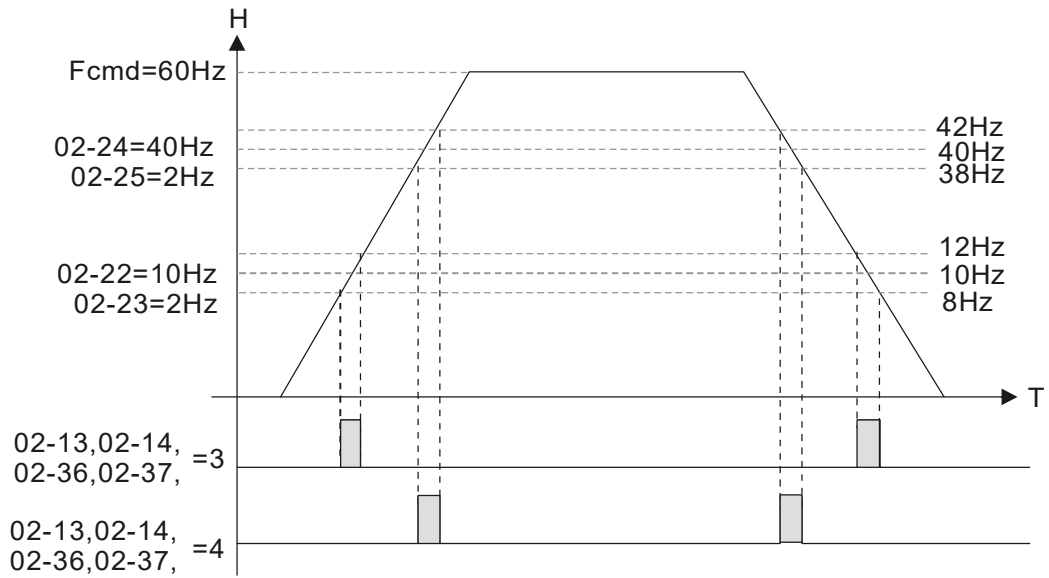

**02-32**

Brake Delay Time

Default: 0.000

Settings 0.000~65.000 sec.

When the AC motor drive runs after Pr. 02-32 delay time, the corresponding multi-function output terminal (12: mechanical brake release) will be ON. It has to use this function with DC brake.

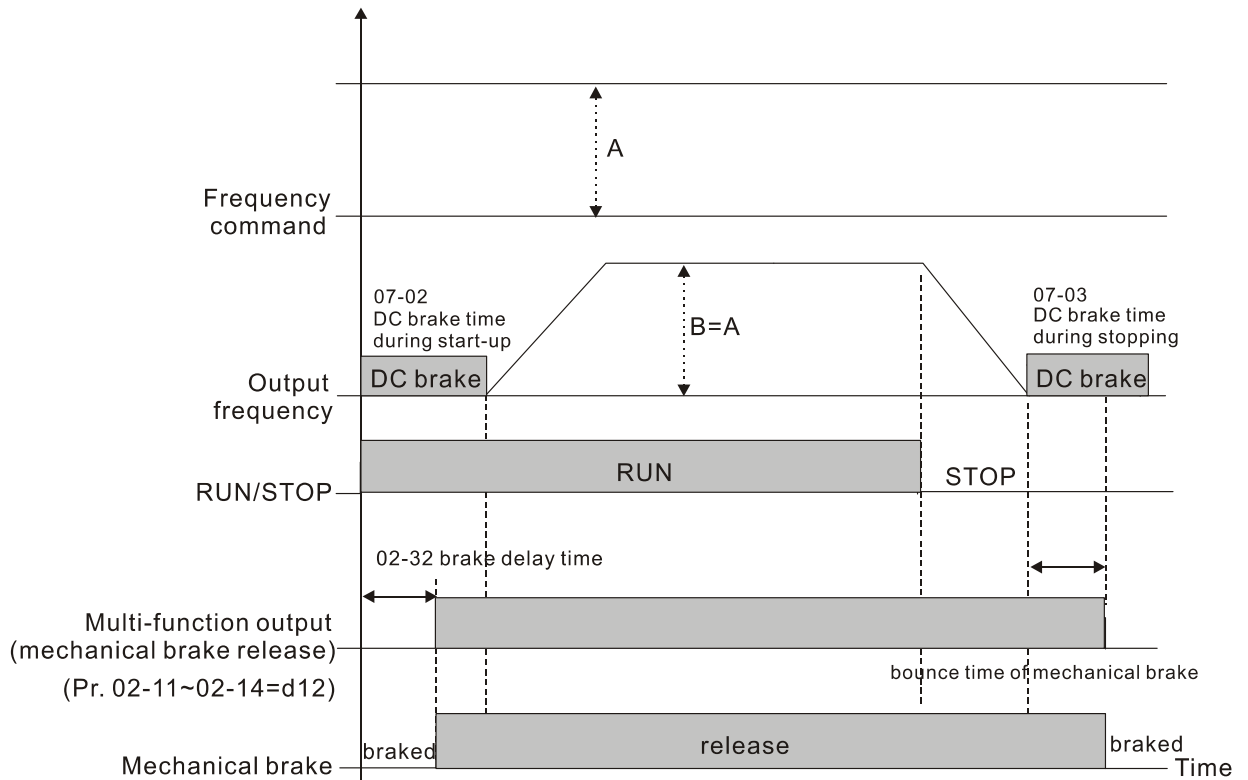

📖 If this parameter is used without DC brake, it will be invalid. Refer to the following operation timing.

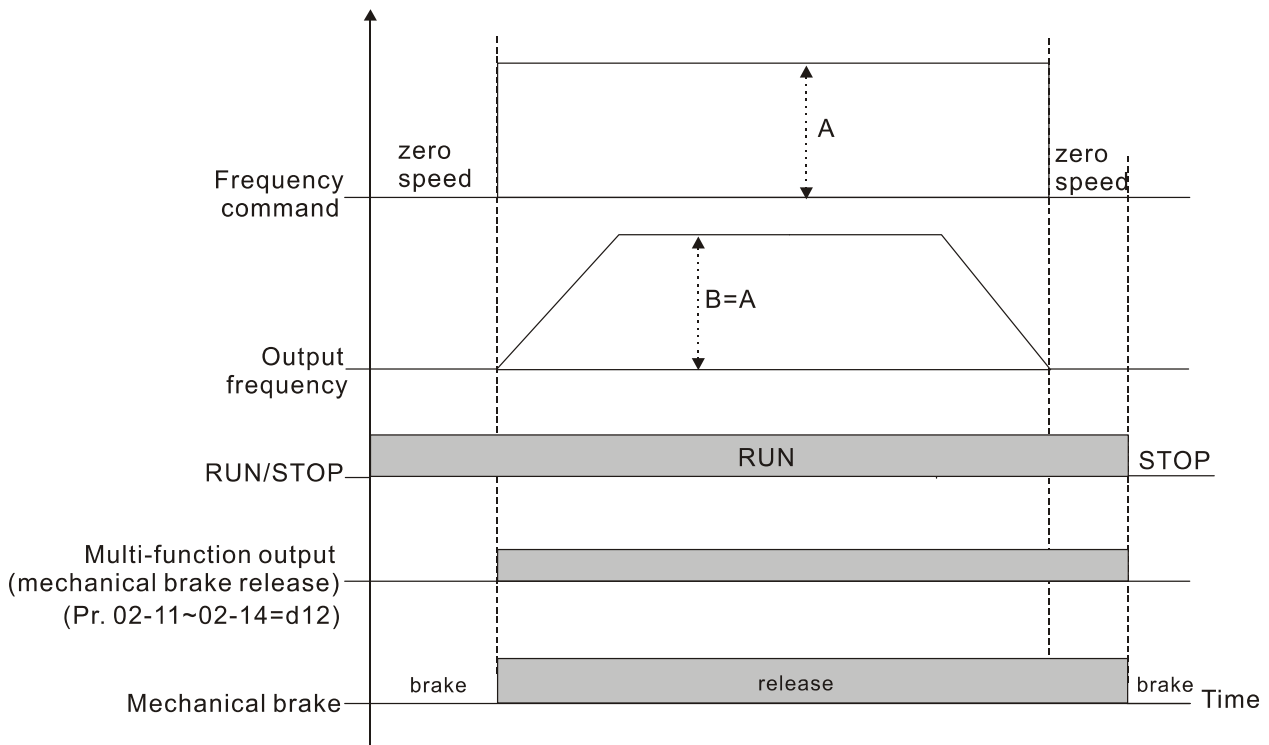

🔪 **02-33** Output Current Level Setting for Multi-function Output Terminals Default: 0

Settings 0~100%

- 📖 When output current is higher or equal to Pr. 02-33, it will activate multi-function output terminal (Pr. 02-13, Pr. 02-14, Pr. 02-16, and Pr. 02-17 is set to 27).
- 📖 When output current is lower or equal to Pr. 02-33, it will activate multi-function output terminal (Pr. 02-13, Pr. 02-14, Pr. 02-16, and Pr. 02-17 is set to 28).

🔪 **02-34** Output Boundary for Multi-function Output Terminals Default: 3.00

Settings 0.00~599.00Hz (Motor speed when using PG)

- 📖 When output frequency is higher or equal to Pr. 02-34 (actual output frequency  $H \geq$  Pr. 02-34), it will activate the multi-function terminal (Pr. 02-13, Pr. 02-14, Pr. 02-16, Pr. 02-17 is set to 29).
- 📖 When output frequency is lower or equal to Pr. 02-34 (actual output frequency  $H <$  Pr. 02-34), it will activate the multi-function terminal (Pr. 02-13, Pr. 02-14, Pr. 02-16, Pr. 02-17 is set to 30).

🔪 **02-35** External Operation Control Selection after Reset and Activate Default: 0

Settings 0: Disable

1: Drive runs if the run command still exists after reset or re-boots.

Set value as 1:

- 📖 Status 1: After the drive is powered on and the external terminal for RUN stays ON, the drive runs.
- 📖 Status 2: After clearing a fault once a fault is detected and the external terminal for RUN stays ON, you can run the drive by pressing the RESET key.

➤ **02-47** Motor Zero-speed Level

Default: 0

Settings 0~65535 rpm

📖 This parameter should be used with the multi-function output terminals (set to 43). It needs to be used with PG card and motor with encoder feedback.

📖 Use this parameter to set the level of motor at zero-speed. When the speed is lower than this setting, the corresponding multi-function output terminal that is set to 43 is ON, as shown below:

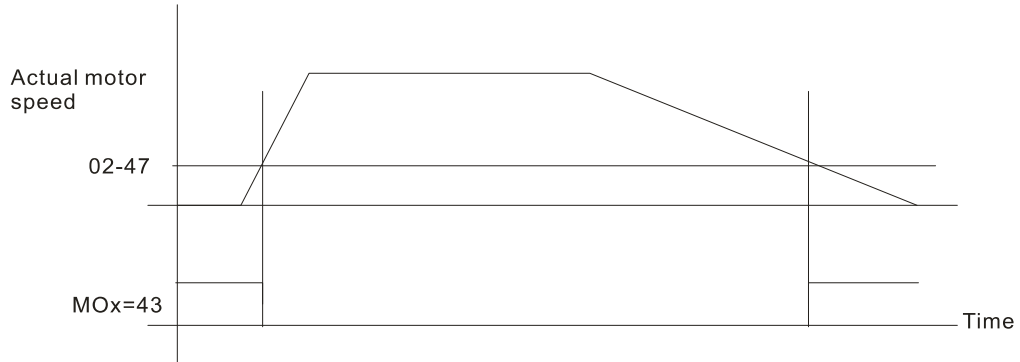

➤ **02-48** Maximum Frequency of Resolution Switch

Default: 60.00

Settings 0.00~599.00Hz

➤ **02-49** Switch delay time of Maximum output frequency

Default: 0.000

Settings 0~65.000 sec.

📖 Use to improve unstable speed or unstable position due to insufficient analog resolution. Use with the external terminal (setting to 43). After setting this parameter, you also need to adjust the analog output resolution of the controller so as to work with the parameter function.

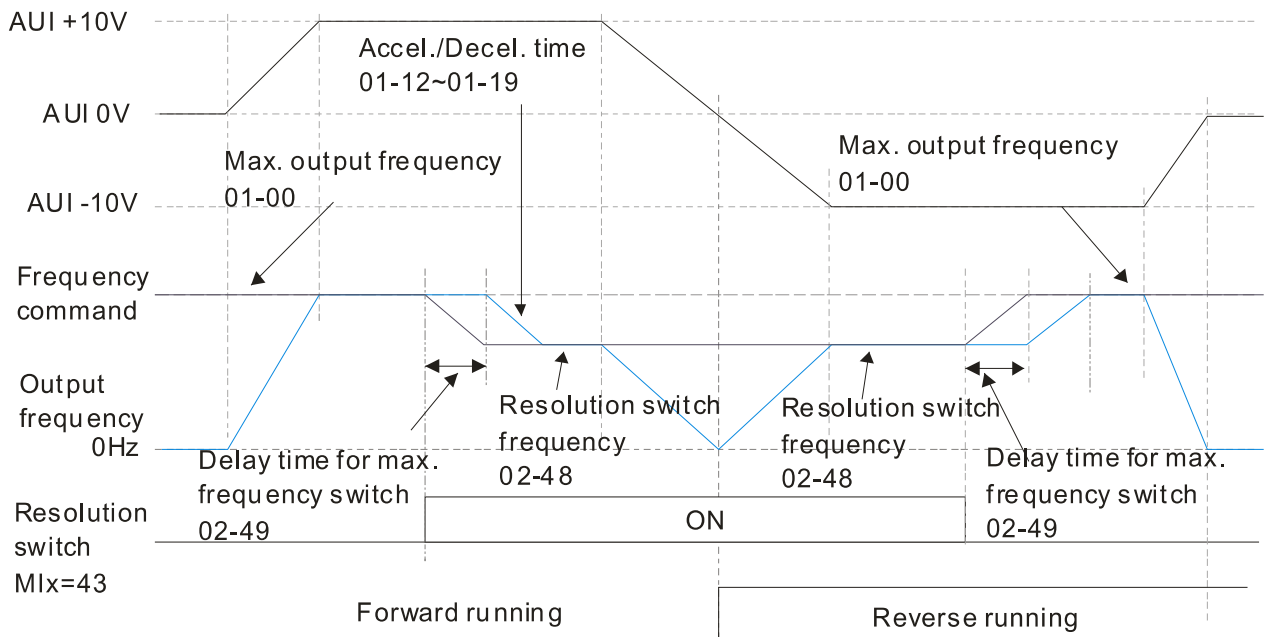

**02-50** Display the Status of Multi-function Input Terminal

Default: Read only

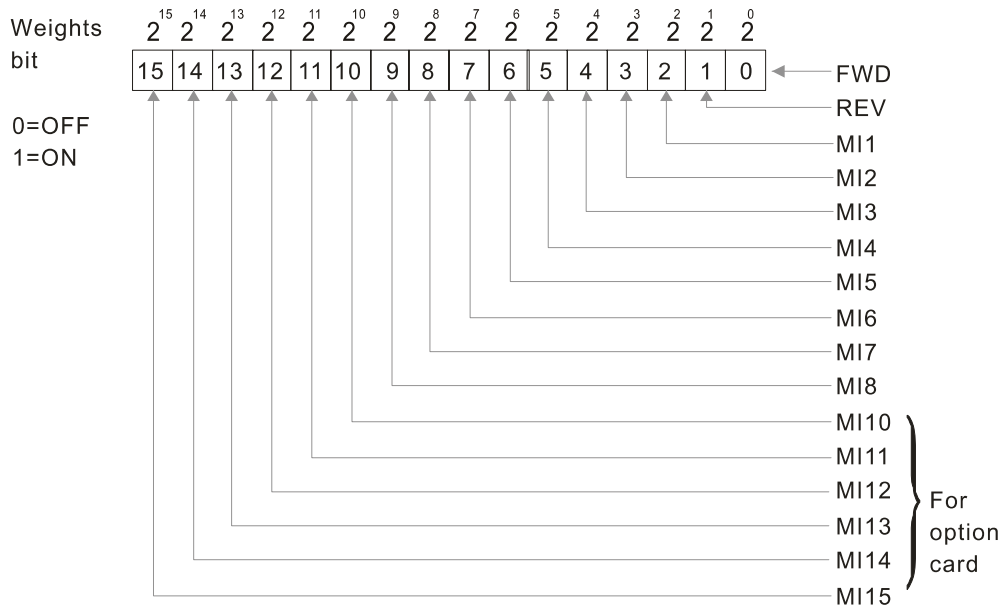

For Example:

When Pr.02-50 displays 0034h (hex) (that is, the value is 52 (decimal) and 110100 (binary)), it means that MI1, MI3 and MI4 are ON.

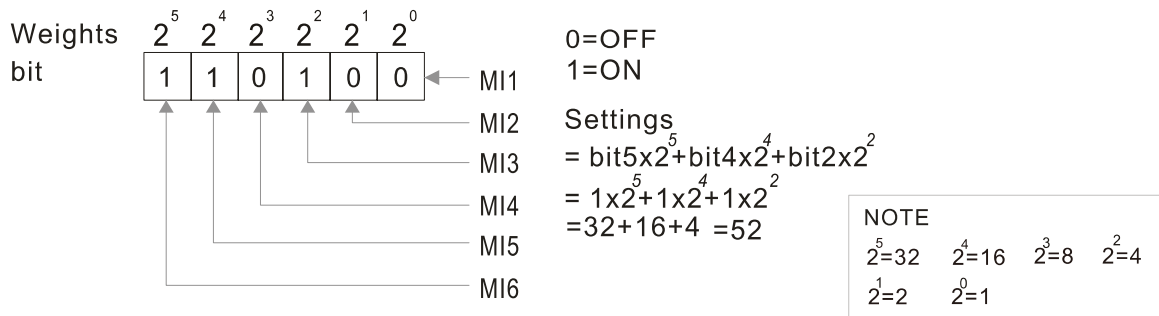

**02-51** Display the status of multi-function output terminal

Default: Read only

For Example:

When Pr.02-51 displays 000 Bh (hex) (that is, the value is 11 (decimal) and 1011 (binary)), it means that RY1, RY2, and MO1 are ON.

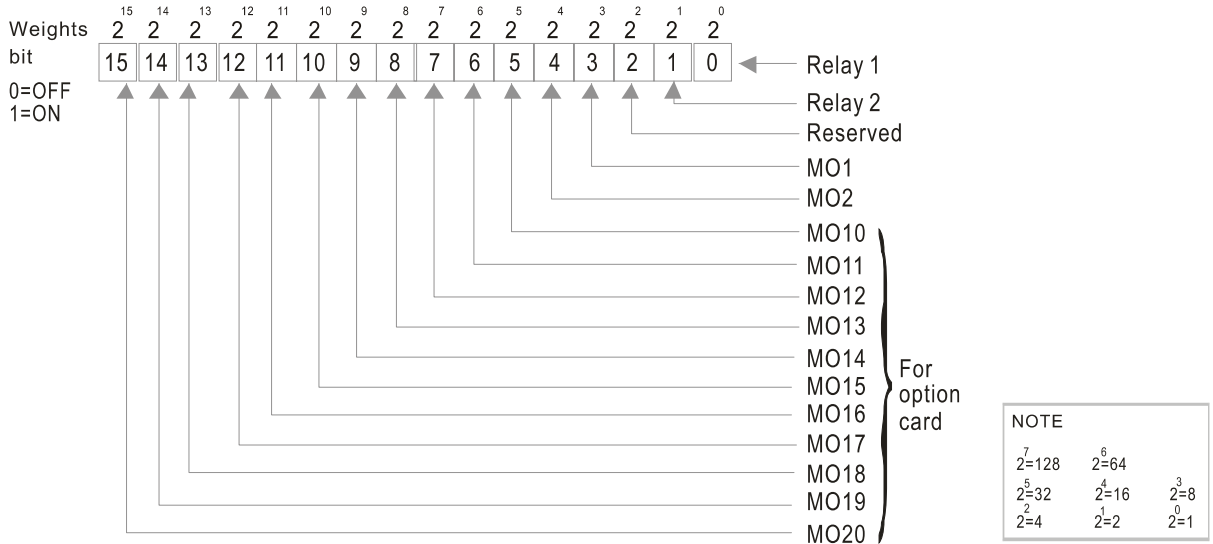

**02-52** Display the External Output Terminals Used by PLC

Default: Read only

Pr.02-52 shows the external multi-function input terminal that used by PLC.

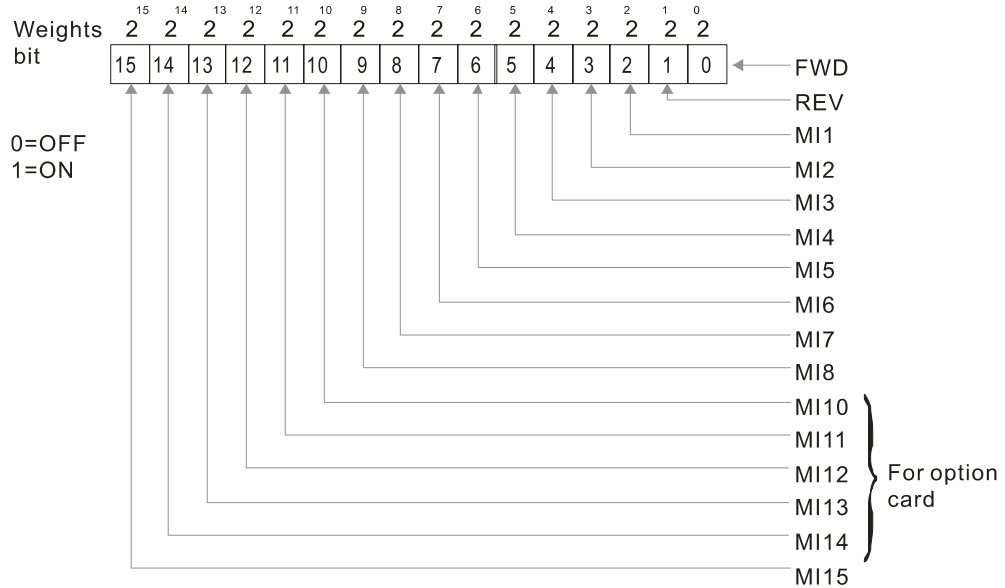

For Example:

When Pr.02-52 displays 0034h (hex) (that is, the value is 52 (decimal) and 110100 (binary)), it means that MI1, MI3 and MI4 are used by PLC.

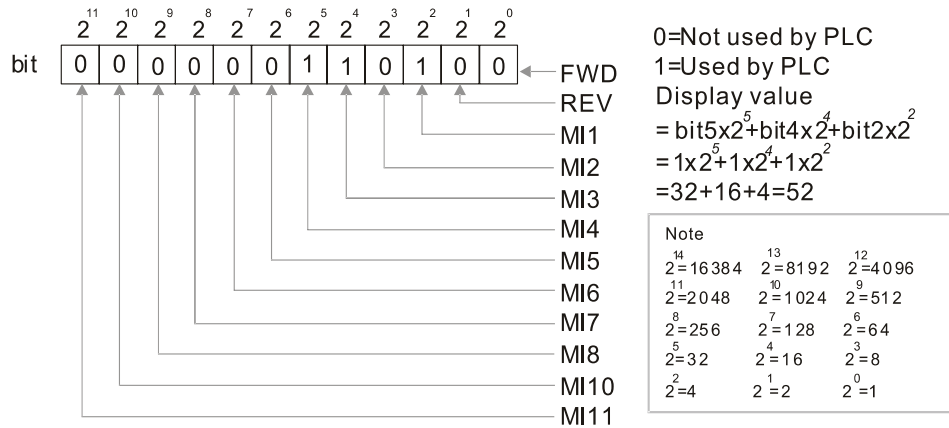

**02-53** Display the External Multi-function Output Terminals Used by PLC

Default: Read only

Pr. 02-53 shows the external multi-function output terminal that used by PLC.

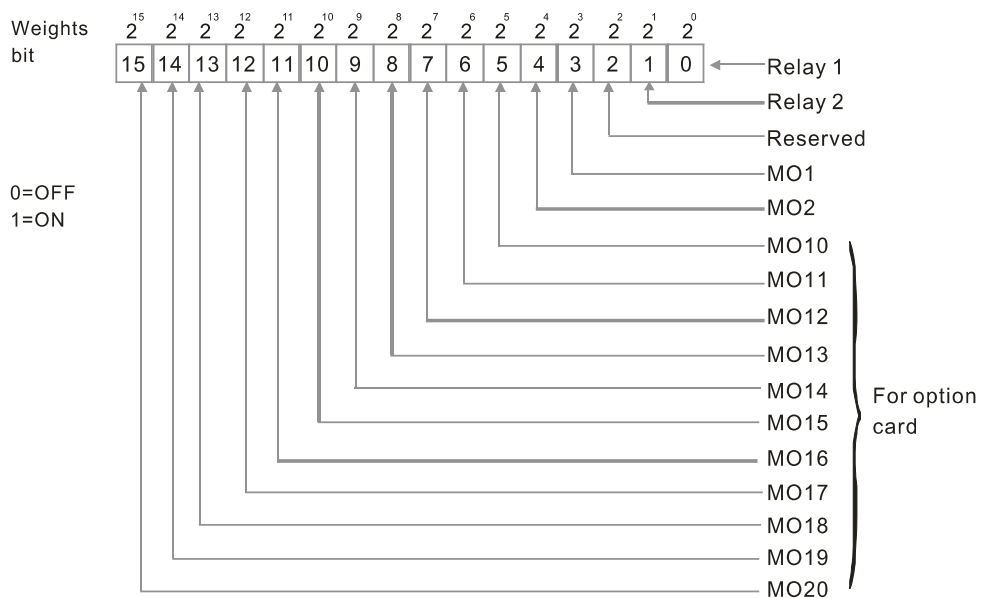

For Example:

When Pr.02-53 displays 0003h (hex) (that is, the value is 3 (decimal) and 0011 (binary)), it means that RY1 and RY2 are used by PLC.

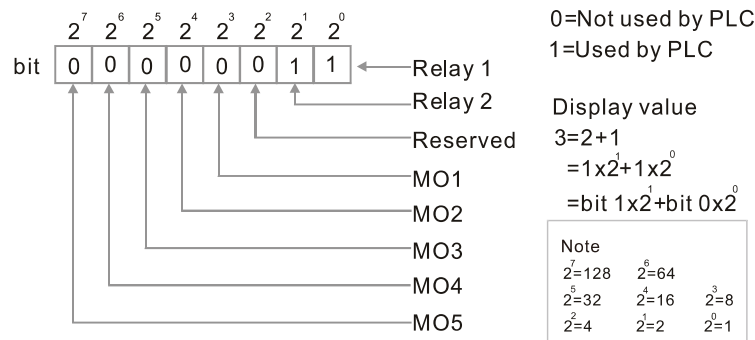

**02-54** Display the Frequency Command Executed by External Terminal

Default: Read only

Settings 0.00~599.00Hz (Read only)

- When you set the source of the Frequency command as the external terminal, if Lv or Fault occurs, the external terminal Frequency command is saved in this parameter.

**02-56** Release Brake Check

Default: 0.000 sec.

Settings 0.000~65.000 sec.

- The parameter needs to be used with Mlx=55. This is to be set for the time difference of mechanical brake delay time and actual brake operation.

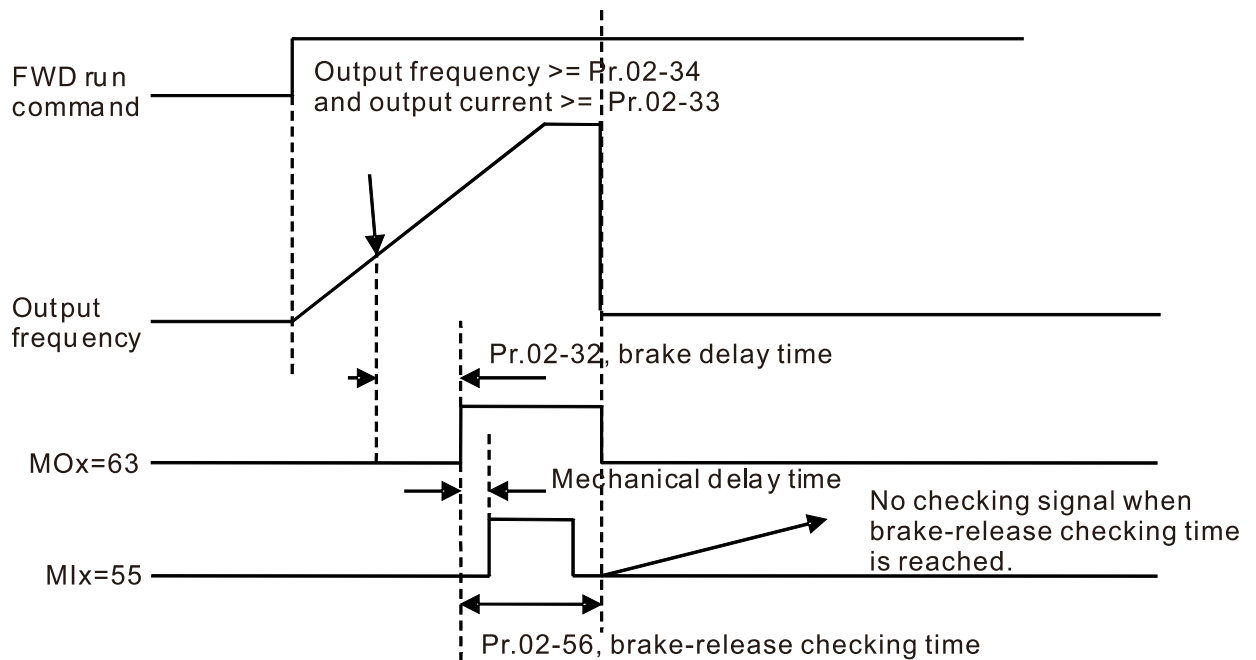
**02-57** Multi-function output terminal: Function 42: Brake Current Check Point

Default: 0

Settings 0~100%

**02-58** Multi-function output terminal (Function 42) : Brake Frequency Check Point

Default: 0.00

Settings 0.00~599.00Hz

- Pr. 02-32, Pr. 02-33, Pr. 02-34, Pr. 02-57 and Pr. 02-58 can be applied on setting up cranes. (Choose crane action #42 to set up multi-function output Pr. 02-13, Pr. 02-14, Pr. 02-16 and Pr. 02-17)
- When output current of a drive is higher than the setting of Pr. 02-33 Pivot Point of the Current ( $\geq$  Pr. 02-33) and when output frequency is higher than the setting of Pr. 02-34 Pivot Point of the Frequency ( $\geq$  Pr. 02-34), choose #42 to set up Multi-function output Pr. 02-13, Pr. 02-14, Pr. 02-16 and Pr. 02-17 after the delay time set at Pr. 02-32.
- When the Pivot Point of the Current 's setting Pr. 02-57 $\neq$ 0 and when the output current of the drive is lower than the setting of Pr. 02-57 ( $<$  Pr. 02-57), or when the output frequency is lower than the setting of Pr.02-58 ( $<$  Pr. 02-58), then disable the setting #42 of the multi-function output Pr. 02-13, Pr. 02-14, Pr. 02-16 and Pr. 02-17



- When Pr. 02-57 = 0, the output current is lower than the setting of Pr. 02-33 Pivot Point of the current (< Pr. 02-33) or when output frequency is lower than the setting of Pr. 02-58(< Pr. 02-58), disable the setting of #42 of the multi-function output Pr. 02-13, Pr. 02-14, Pr. 02-16 and Pr. 02-17.
- For crane application, when MOx=42, the setting of Pr. 02-34 must be greater than Pr. 02-58; and Pr. 02-33 must be greater than Pr. 02-57.

**02-63** Frequency Reached Detection Amplitude Default: 0.00

---

Settings 0.00~599.00Hz

**02-70** IO Card Type Default: Read only

---

Settings Read only

- 1: EMC-BPS01 Card
- 4: EMC-D611A Card
- 5: EMC-D42A Card
- 6: EMC-R6AA Card
- 11: EMC-A22A

**02-71** DFM Output Selection Default: 0

---

Settings 0: Use frequency with speed control as DFM output frequency  
1: Use frequency with system accel./decel. as DFM output frequency

**02-74** Internal/External Multi-function Input Terminals Selection Default: 0000h

---

Settings 0000~FFFFh

This parameter is used to select the terminals MI1~MI15 to be internal terminal or external terminal. When the MIx has set as internal terminal, then the corresponding external terminal function will be disabled.

To activate internal terminals via Pr. 02-75 setting.

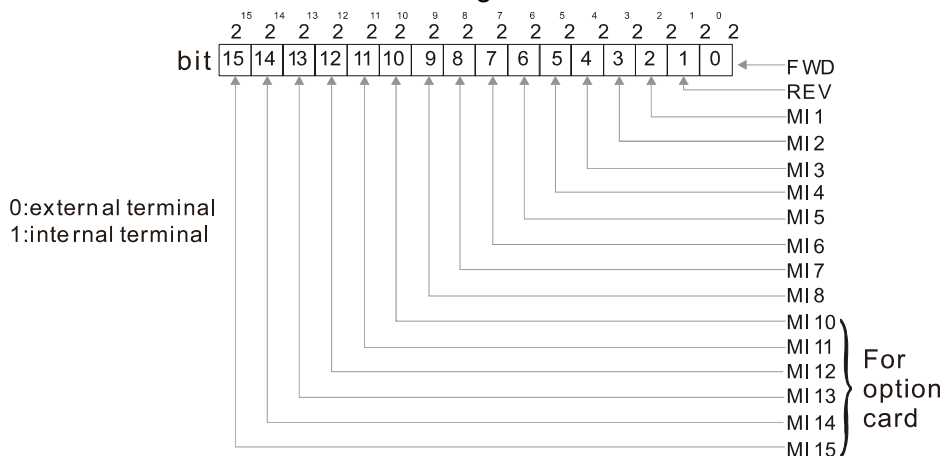

The setting method is to convert binary number to hexadecimal number for input.

For example: if setting MI1, MI3, MI4 to be internal terminals, the setting value should be  $\text{bit}5 \times 2^5 + \text{bit}4 \times 2^4 + \text{bit}2 \times 2^2 = 1 \times 2^5 + 1 \times 2^4 + 1 \times 2^2 = 32 + 16 + 4 = 52$  as shown in the following. The  $52_{10} = 32_{16}$ , Pr. 02-74 = 34h.

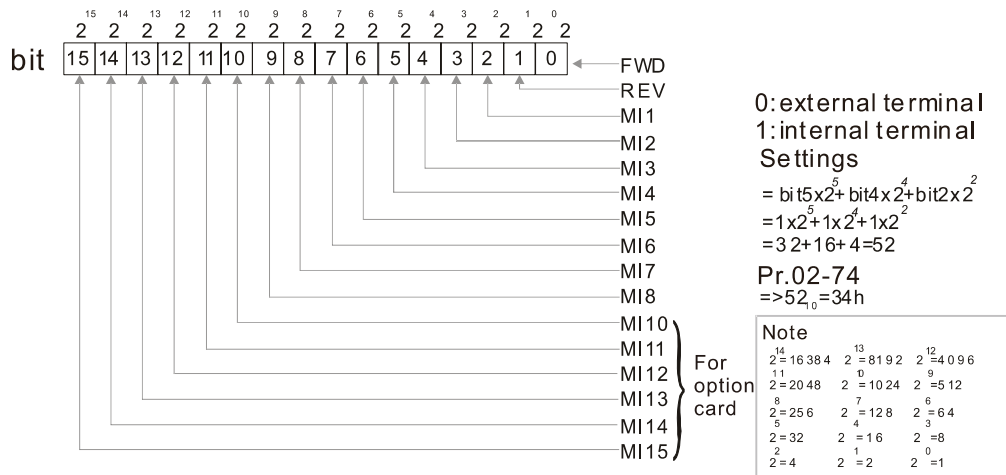

**02-75** Internal Multi-function Output Terminal Selection

Default: 0000h

Settings 0000~FFFFh

This parameter is used to set the internal terminal action via keypad, communication or PLC.

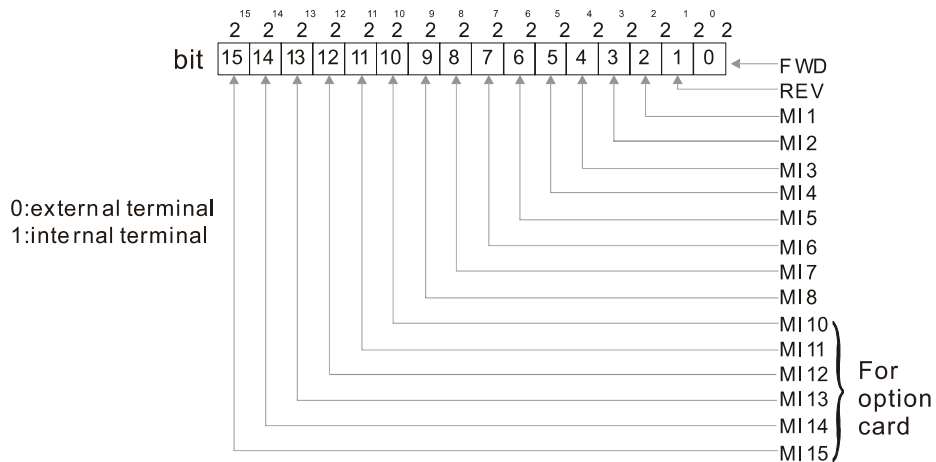

For example, if setting MI1, MI3 and MI4 to be ON, Pr.02-75 should be set to  $\text{bit}5 \times 2^5 + \text{bit}4 \times 2^4 + \text{bit}2 \times 2^2 = 1 \times 2^5 + 1 \times 2^4 + 1 \times 2^2 = 32 + 16 + 4 = 52 = 34_{16}$  as shown in the following.

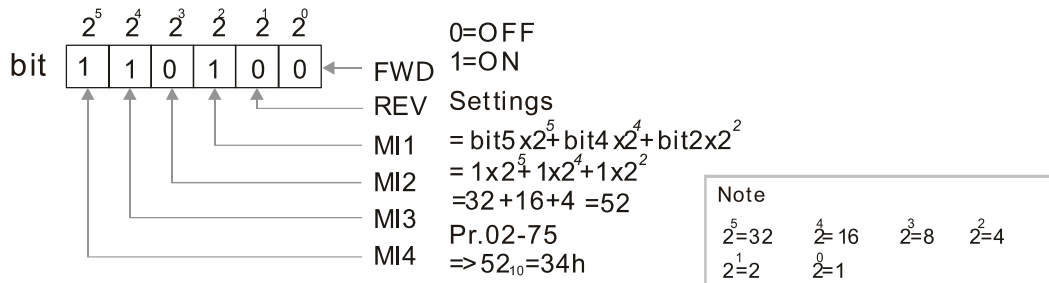

- The Local/Remote of Digital operation panel has the lowest priority.
- When the built-in PLC has use a MIx, the original function of this MIx can still be triggered via virtual terminal.
- Pr. 02-74 and Pr. 02-75 can both do running change.
- Pr. 02-74 and Pr. 02-75 setting value are both memorized before power off.
- The virtual terminal trigger can still be selected by the setting of Pr. 02-12 Digital Input Operation Setting (Pr. 02-12=0 N.O. or Pr. 02-12=1 N.C.)

### 03 Analog Input/Output Parameter ✎ This parameter can be set during operation.

✎ <b>03-00</b> Analog Input Selection (AVI)	Default: 1
✎ <b>03-01</b> Analog Input Selection (ACI)	Default: 0
✎ <b>03-02</b> Analog Input Selection (AUI)	Default: 0

#### Settings

0: No function

1: Frequency command (speed limit under torque control mode)

2: Torque command (torque limit under speed mode)

3: Torque compensation command

4: PID target value

5: PID feedback signal

6: Thermistor (PTC / KTY-84) input value

7: Positive torque limit

8: Negative torque limit

9: Regenerative torque limit

10: Positive / negative torque limit

11: PT100 thermistor input value

13: PID compensation value

 When you use analog input as the PID reference target value, you must set Pr. 00-20 to 2 (analog input).

Setting method 1: Pr. 03-00–03-02 set 1 as PID reference target input.

Setting method 2: Pr. 03-00–03-02 set 4 as PID reference target input.

If the setting value 1 and setting value 4 exist at the same time, the AVI input has highest priority to become the PID reference target input value.

 When you use analog input as the PID compensation value, you must set Pr. 08-16 to 1 (source of PID compensation value is analog input). You can see the compensation value with Pr. 08-17.

 When you use the frequency command or TQC speed limit, the corresponding value for 0–±10V / 4–20mA is 0–maximum output frequency (Pr. 01-00).

 When you use torque command or torque limit, the corresponding value for 0–±10V / 4–20mA is 0 to maximum output torque (Pr. 11-27).

 When you use the torque compensation, the corresponding value for 0–±10V / 4–20mA is 0–the motor rated torque.

 The analog input AVI / ACI (use with Switch terminal to switch SW2 to 0–10V) supports KTY84. The AUI does not support this function.

 When you use KTY84, you can only choose either AVI or ACI at the same time. The AVI is prior to ACI.

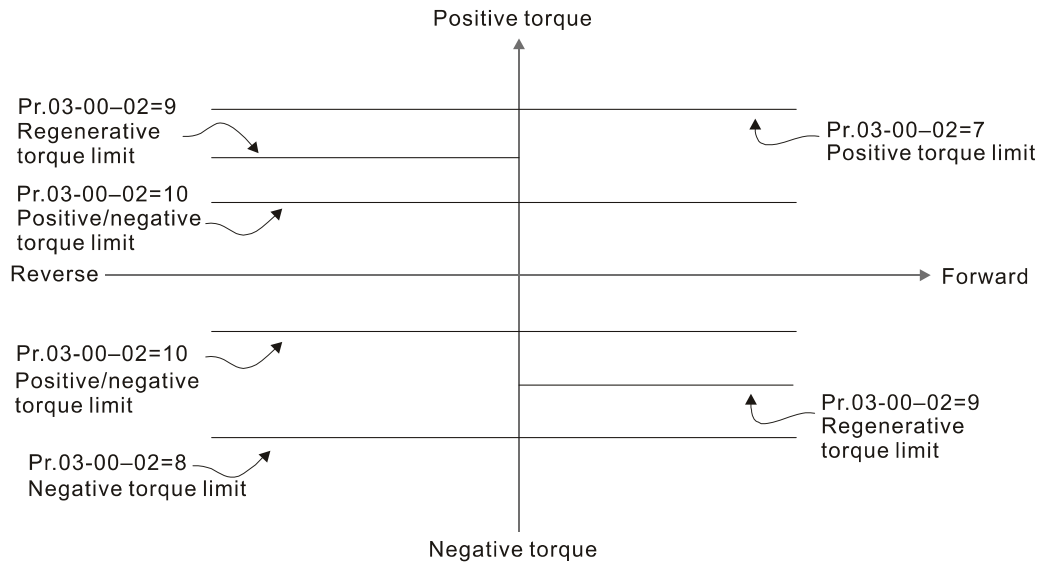

📖 When the settings for Pr. 03-00–Pr. 03-02 are the same, the AVI input is selected first.

⚡ **03-03** Analog Input Bias (AVI) Default: 0.0

Settings -100.0–100.0%

📖 Sets the corresponding AVI voltage for the external analog input 0.

⚡ **03-04** Analog Input Bias (ACI) Default: 0.0

Settings -100.0–100.0%

📖 Sets the corresponding ACI voltage for the external analog input 0.

⚡ **03-05** Analog Voltage Input Bias (AUI) Default: 0.0

Settings -100.0–100.0%

📖 Sets the corresponding AUI voltage for the external analog input 0.

📖 The corresponding external input voltage / current signal and the set frequency is 0–10V (4–20mA) corresponds to 0–maximum frequency.

⚡ **03-07** Positive / Negative Bias Mode (AVI)

⚡ **03-08** Positive / Negative Bias Mode (ACI)

⚡ **03-09** Positive / Negative Bias Mode (AUI) Default: 0

Settings 0: No bias

1: Lower than or equal to bias

2: Greater than or equal to bias

3: The absolute value of the bias voltage while serving as the center

4: Serve bias as the center

📖 In a noisy environment, use negative bias to provide a noise margin. Do NOT use less than 1V to set the operation frequency.

**In the diagram below: Black line: Curve with no bias. Gray line: curve with bias**

1.

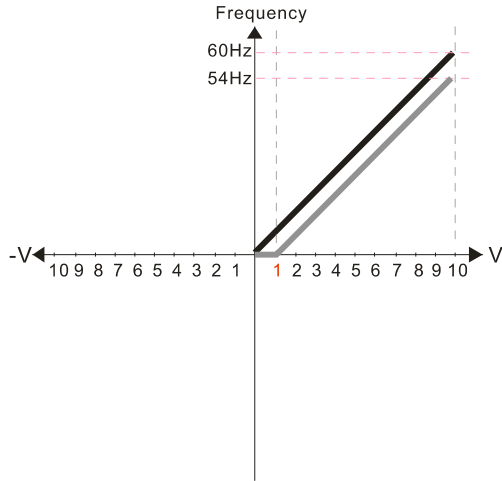

Pr.03-03=10%  
 Pr.03-07~03-09 (Positive/Negative Bias Mode)  
 0: No bias  
 1: Lower than or equal to bias  
 2: Greater than or equal to bias  
 3: The absolute value of the bias voltage while serving as the center  
 4: Serve bias as the center  
 Pr.03-10 (Analog Frequency Command for Reverse Run)  
 0: Negative frequency is not valid. Forward and reverse run is controlled by digital keypad or external terminal.  
 1: Neagtive frequency is valid. Positive frequency = forward run; negative frequency = reverse run. Direction can not be switched by digital keypad or external teriminal control.  
 Pr.03-11 Analog Input Gain (AVI)= 100%

2.

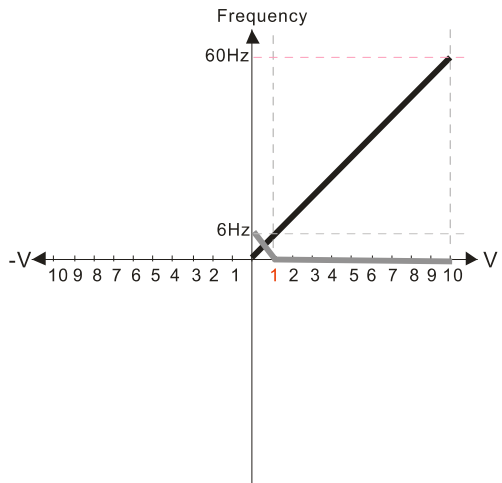

Pr.03-03=10%  
 Pr.03-07~03-09 (Positive/Negative Bias Mode)  
 0: No bias  
 1: Lower than or equal to bias  
 2: Greater than or equal to bias  
 3: The absolute value of the bias voltage while serving as the center  
 4: Serve bias as the center  
 Pr.03-10 (Analog Frequency Command for Reverse Run)  
 0: Negative frequency is not valid. Forward and reverse run is controlled by digital keypad or external terminal.  
 1: Neagtive frequency is valid. Positive frequency = forward run; negative frequency = reverse run. Direction can not be switched by digital keypad or external teriminal control.  
 Pr.03-11 Analog Input Gain (AVI)=100%

3.

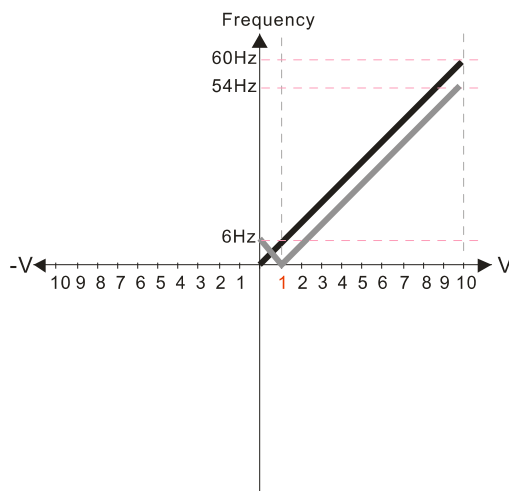

Pr.03-03=10%  
 Pr.03-07~03-09 (Positive/Negative Bias Mode)  
 0: No bias  
 1: Lower than or equal to bias  
 2: Greater than or equal to bias  
 3: The absolute value of the bias voltage while serving as the center  
 4: Serve bias as the center  
 Pr.03-10 (Analog Frequency Command for Reverse Run)  
 0: Negative frequency is not valid. Forward and reverse run is controlled by digital keypad or external terminal.  
 1: Neagtive frequency is valid. Positive frequency = forward run; negative frequency = reverse run. Direction can not be switched by digital keypad or external teriminal control.  
 Pr.03-11 Analog Input Gain (AVI) = 100%

4.

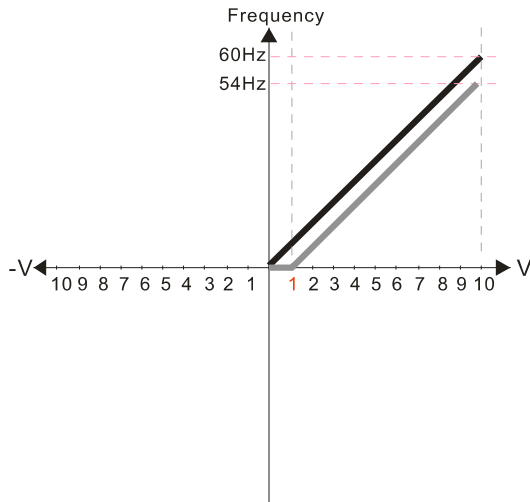

Pr.03-03=10%

Pr.03-07~03-09 (Positive/Negative Bias Mode)

- 0: No bias
- 1: Lower than or equal to bias
- 2: Greater than or equal to bias
- 3: The absolute value of the bias voltage while serving as the center
- 4: Serve bias as the center

Pr.03-10 (Analog Frequency Command for Reverse Run)

- 0: Negative frequency is not valid. Forward and reverse run is controlled by digital keypad or external terminal.

- 1: Neagtive frequency is valid. Positive frequency = forward run; negative frequency = reverse run. Direction can not be switched by digital keypad or external teriminal control.

Pr.03-11 Analog Input Gain (AVI) = 100%

5.

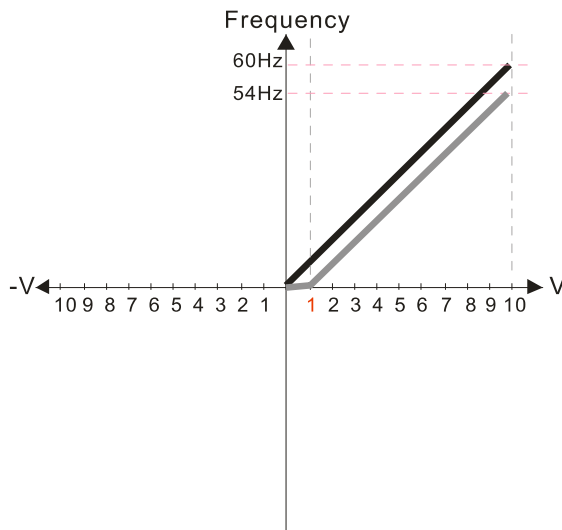

Pr.03-03=10%

Pr.03-07~03-09 (Positive/Negative Bias Mode)

- 0: No bias
- 1: Lower than or equal to bias
- 2: Greater than or equal to bias
- 3: The absolute value of the bias voltage while serving as the center
- 4: Serve bias as the center

Pr.03-10 (Analog Frequency Command for Reverse Run)

- 0: Negative frequency is not valid. Forward and reverse run is controlled by digital keypad or external terminal.

- 1: Neagtive frequency is valid. Positive frequency = forward run; negative frequency = reverse run. Direction can not be switched by digital keypad or external teriminal control.

Pr.03-11 Analog Input Gain (AVI)= 100%

6.

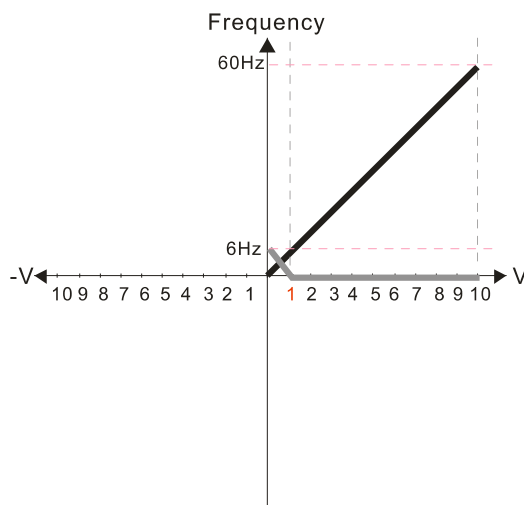

Pr.03-03=10%

Pr.03-07~03-09 (Positive/Negative Bias Mode)

- 0: No bias
- 1: Lower than or equal to bias
- 2: Greater than or equal to bias
- 3: The absolute value of the bias voltage while serving as the center
- 4: Serve bias as the center

Pr.03-10 (Analog Frequency Command for Reverse Run)

- 0: Negative frequency is not valid. Forward and reverse run is controlled by digital keypad or external terminal.

- 1: Neagtive frequency is valid. Positive frequency = forward run; negative frequency = reverse run. Direction can not be switched by digital keypad or external teriminal control.

Pr.03-11 Analog Input Gain (AVI)= 100%

7.

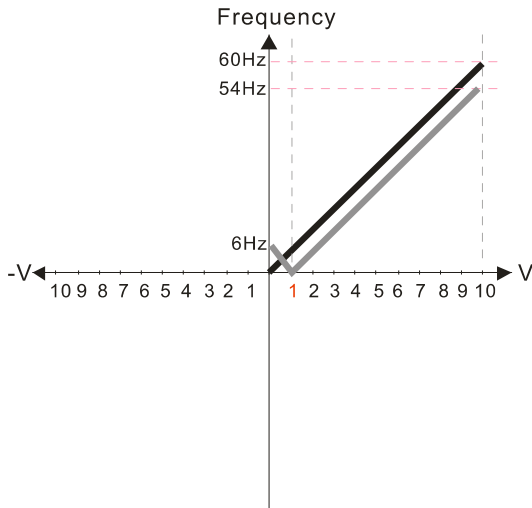

Pr.03-03=10%

Pr.03-07~03-09 (Positive/Negative Bias Mode)

- 0: No bias
- 1: Lower than or equal to bias
- 2: Greater than or equal to bias
- 3: The absolute value of the bias voltage while serving as the center
- 4: Serve bias as the center

Pr.03-10 (Analog Frequency Command for Reverse Run)

- 0: Negative frequency is not valid. Forward and reverse run is controlled by digital keypad or external terminal.
- 1: Negative frequency is valid. Positive frequency = forward run; negative frequency = reverse run. Direction can not be switched by digital keypad or external terminal control.

Pr.03-11 Analog Input Gain (AVI) = 100%

8.

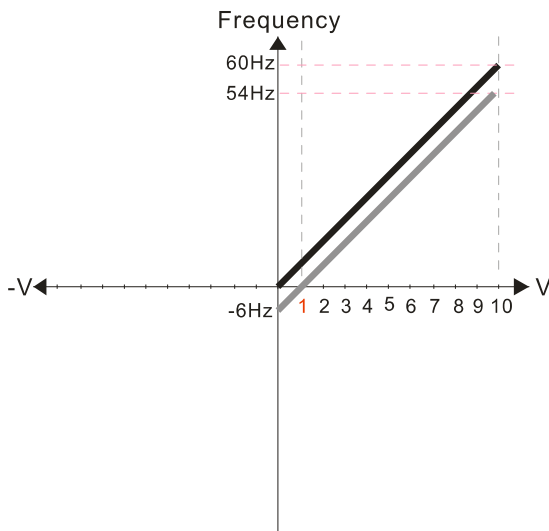

Pr.03-03=10%

Pr.03-07~03-09 (Positive/Negative Bias Mode)

- 0: No bias
- 1: Lower than or equal to bias
- 2: Greater than or equal to bias
- 3: The absolute value of the bias voltage while serving as the center
- 4: Serve bias as the center

Pr.03-10 (Analog Frequency Command for Reverse Run)

- 0: Negative frequency is not valid. Forward and reverse run is controlled by digital keypad or external terminal.
- 1: Negative frequency is valid. Positive frequency = forward run; negative frequency = reverse run. Direction can not be switched by digital keypad or external terminal control.

Pr.03-11 Analog Input Gain (AVI) = 100%

9.

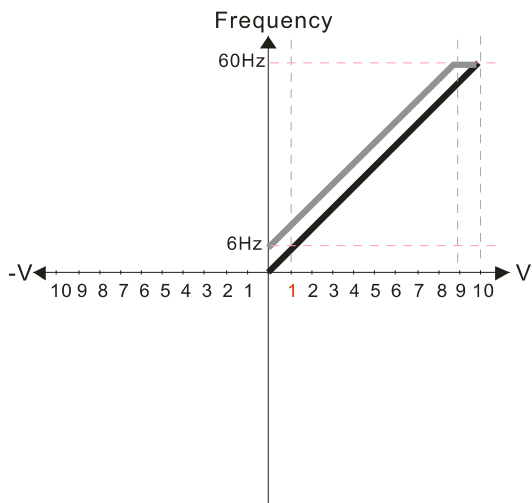

Pr.03-03=-10%

Pr.03-07~03-09 (Positive/Negative Bias Mode)

- 0: No bias
- 1: Lower than or equal to bias
- 2: Greater than or equal to bias
- 3: The absolute value of the bias voltage while serving as the center
- 4: Serve bias as the center

Pr.03-10 (Analog Frequency Command for Reverse Run)

- 0: Negative frequency is not valid. Forward and reverse run is controlled by digital keypad or external terminal.
- 1: Negative frequency is valid. Positive frequency = forward run; negative frequency = reverse run. Direction can not be switched by digital keypad or external terminal control.

Pr.03-11 Analog Input Gain (AVI)= 100%

10.

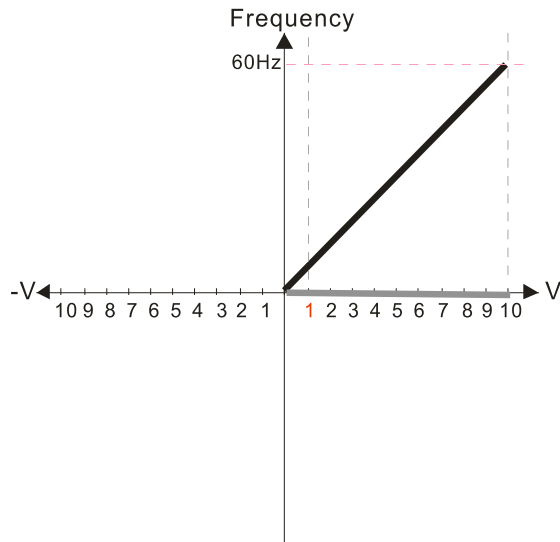

Pr.03-03=-10%

Pr.03-07~03-09 (Positive/Negative Bias Mode)

- 0: No bias
- 1: Lower than or equal to bias
- 2: Greater than or equal to bias**
- 3: The absolute value of the bias voltage while serving as the center
- 4: Serve bias as the center

Pr.03-10 (Analog Frequency Command for Reverse Run)

**0: Negative frequency is not valid. Forward and reverse run is controlled by digital keypad or external terminal.**

- 1: Negative frequency is valid. Positive frequency = forward run; negative frequency = reverse run. Direction can not be switched by digital keypad or external terminal control.

Pr.03-11 Analog Input Gain (AVI)= 100%

11.

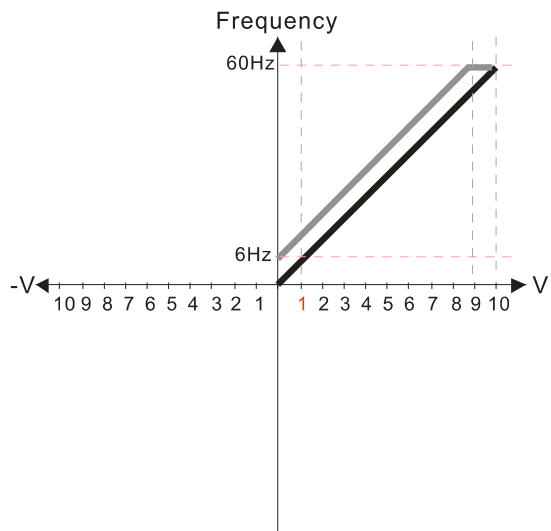

Pr.03-03=-10%

Pr.03-07~03-09 (Positive/Negative Bias Mode)

- 0: No bias
- 1: Lower than or equal to bias
- 2: Greater than or equal to bias
- 3: The absolute value of the bias voltage while serving as the center**
- 4: Serve bias as the center

Pr.03-10 (Analog Frequency Command for Reverse Run)

**0: Negative frequency is not valid. Forward and reverse run is controlled by digital keypad or external terminal.**

- 1: Negative frequency is valid. Positive frequency = forward run; negative frequency = reverse run. Direction can not be switched by digital keypad or external terminal control.

Pr.03-11 Analog Input Gain (AVI) = 100%

12.

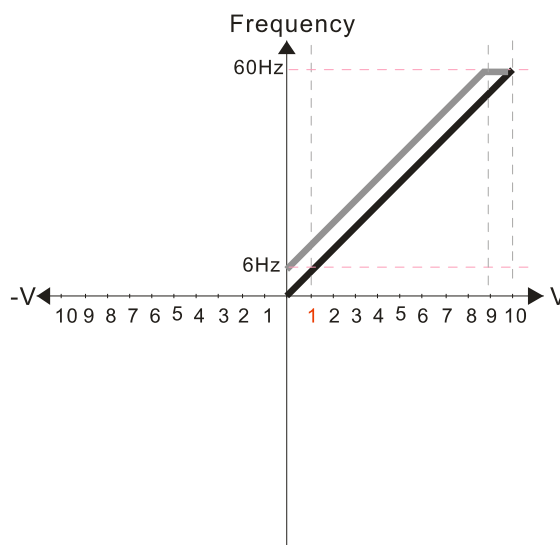

Pr.03-03=-10%

Pr.03-07~03-09 (Positive/Negative Bias Mode)

- 0: No bias
- 1: Lower than or equal to bias
- 2: Greater than or equal to bias
- 3: The absolute value of the bias voltage while serving as the center
- 4: Serve bias as the center**

Pr.03-10 (Analog Frequency Command for Reverse Run)

**0: Negative frequency is not valid. Forward and reverse run is controlled by digital keypad or external terminal.**

- 1: Negative frequency is valid. Positive frequency = forward run; negative frequency = reverse run. Direction can not be switched by digital keypad or external terminal control.

Pr.03-11 Analog Input Gain (AVI) = 100%



13.

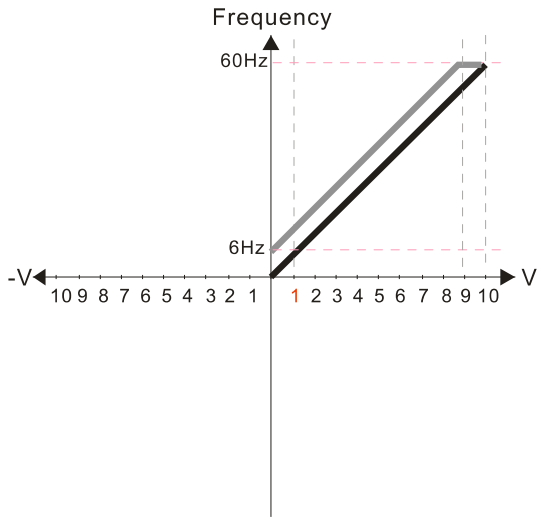

Pr.03-03=-10%

Pr.03-07~03-09 (Positive/Negative Bias Mode)

0: No bias

1: Lower than or equal to bias

2: Greater than or equal to bias

3: The absolute value of the bias voltage while serving as the center

4: Serve bias as the center

Pr.03-10 (Analog Frequency Command for Reverse Run)

0: Negative frequency is not valid.

Forward and reverse run is controlled by digital keypad or external terminal.

1: Negative frequency is valid. Positive frequency = forward run; negative frequency = reverse run. Direction can not be switched by digital keypad or external terminal control.

Pr.03-11 Analog Input Gain (AVI)= 100%

14.

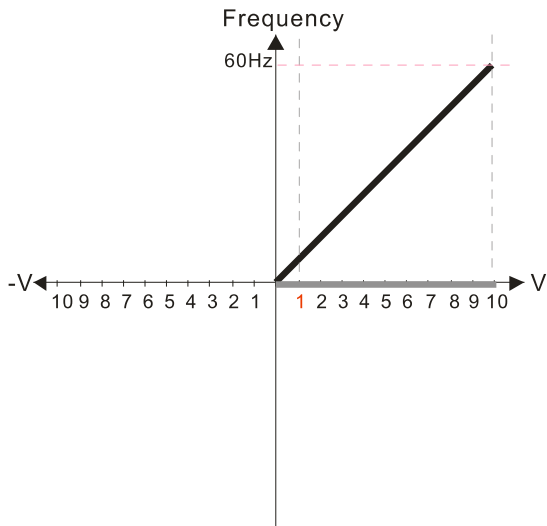

Pr.03-03=-10%

Pr.03-07~03-09 (Positive/Negative Bias Mode)

0: No bias

1: Lower than or equal to bias

2: Greater than or equal to bias

3: The absolute value of the bias voltage while serving as the center

4: Serve bias as the center

Pr.03-10 (Analog Frequency Command for Reverse Run)

0: Negative frequency is not valid.

Forward and reverse run is controlled by digital keypad or external terminal.

1: Negative frequency is valid. Positive frequency = forward run; negative frequency = reverse run. Direction can not be switched by digital keypad or external terminal control.

Pr.03-11 Analog Input Gain (AVI)= 100%

15.

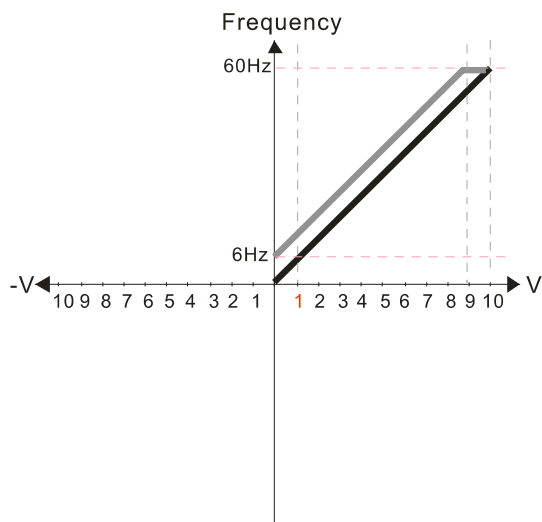

Pr.03-03=-10%

Pr.03-07~03-09 (Positive/Negative Bias Mode)

0: No bias

1: Lower than or equal to bias

2: Greater than or equal to bias

3: The absolute value of the bias voltage while serving as the center

4: Serve bias as the center

Pr.03-10 (Analog Frequency Command for Reverse Run)

0: Negative frequency is not valid.

Forward and reverse run is controlled by digital keypad or external terminal.

1: Negative frequency is valid. Positive frequency = forward run; negative frequency = reverse run. Direction can not be switched by digital keypad or external terminal control.

Pr.03-11 Analog Input Gain (AVI) = 100%

16.

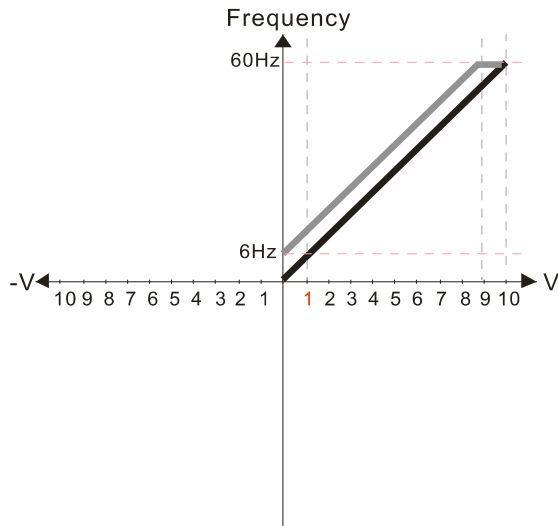

Pr.03-03=-10%

Pr.03-07~03-09 (Positive/Negative Bias Mode)

- 0: No bias
- 1: Lower than or equal to bias
- 2: Greater than or equal to bias
- 3: The absolute value of the bias voltage while serving as the center
- 4: Serve bias as the center**

Pr.03-10 (Analog Frequency Command for Reverse Run)

0: Negative frequency is not valid. Forward and reverse run is controlled by digital keypad or external terminal.

- 1: Neagitive frequency is valid. Positive frequency = forward run; negative frequency = reverse run. Direction can not be switched by digital keypad or external teriminal control.**

Pr.03-11 Analog Input Gain (AVI) = 100%

17.

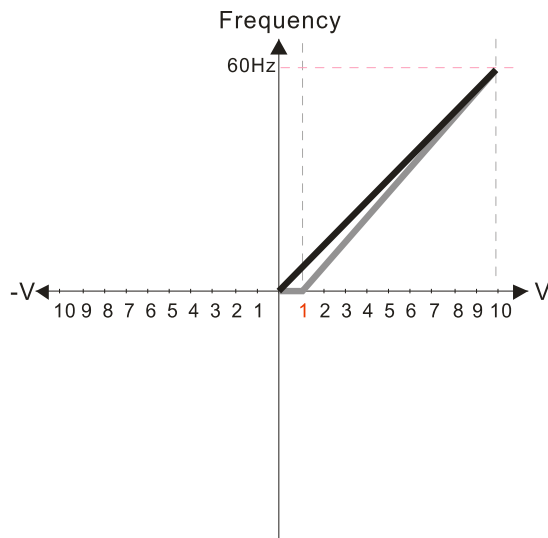

Pr.03-03=10%

Pr.03-07~03-09 (Positive/Negative Bias Mode)

- 0: No bias
- 1: Lower than or equal to bias**
- 2: Greater than or equal to bias
- 3: The absolute value of the bias voltage while serving as the center
- 4: Serve bias as the center

Pr.03-10 (Analog Frequency Command for Reverse Run)

**0: Negative frequency is not valid. Forward and reverse run is controlled by digital keypad or external terminal.**

- 1: Neagitive frequency is valid. Positive frequency = forward run; negative frequency = reverse run. Direction can not be switched by digital keypad or external teriminal control.

Pr.03-11 Analog Input Gain (AVI)= 111.1%

10/9=111.1%

18.

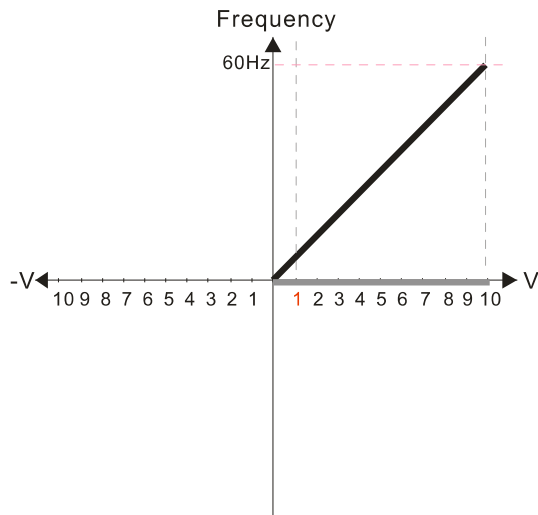

Pr.03-03=10%

Pr.03-07~03-09 (Positive/Negative Bias Mode)

- 0: No bias
- 1: Lower than or equal to bias
- 2: Greater than or equal to bias**
- 3: The absolute value of the bias voltage while serving as the center
- 4: Serve bias as the center

Pr.03-10 (Analog Frequency Command for Reverse Run)

**0: Negative frequency is not valid. Forward and reverse run is controlled by digital keypad or external terminal.**

- 1: Neagitive frequency is valid. Positive frequency = forward run; negative frequency = reverse run. Direction can not be switched by digital keypad or external teriminal control.

Pr.03-11 Analog Input Gain (AVI)=111.1%

10/9 =111.1%

19.

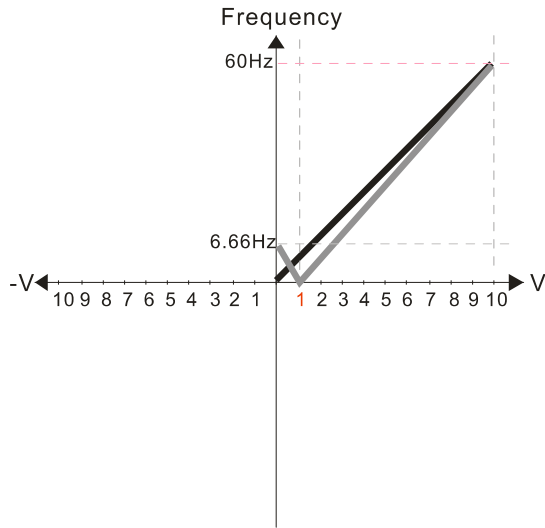

Pr.03-03=10%

Pr.03-07~03-09 (Positive/Negative Bias Mode)

- 0: No bias
- 1: Lower than or equal to bias
- 2: Greater than or equal to bias
- 3: The absolute value of the bias voltage while serving as the center
- 4: Serve bias as the center

Pr.03-10 (Analog Frequency Command for Reverse Run)

0: Negative frequency is not valid. Forward and reverse run is controlled by digital keypad or external terminal.

- 1: Neagtive frequency is valid. Positive frequency = forward run; negative frequency = reverse run. Direction can not be switched by digital keypad or external teriminal control.

Pr.03-11 Analog Input Gain (AVI) = 111.1%  
 $10/9 = 111.1\%$

20.

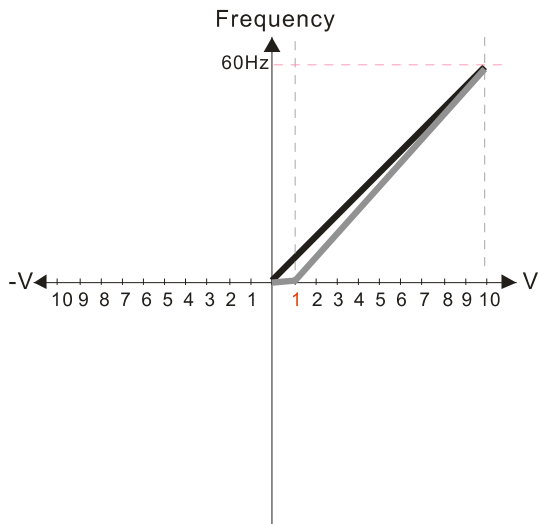

Pr.03-03=10%

Pr.03-07~03-09 (Positive/Negative Bias Mode)

- 0: No bias
- 1: Lower than or equal to bias
- 2: Greater than or equal to bias
- 3: The absolute value of the bias voltage while serving as the center
- 4: Serve bias as the center

Pr.03-10 (Analog Frequency Command for Reverse Run)

0: Negative frequency is not valid. Forward and reverse run is controlled by digital keypad or external terminal.

- 1: Neagtive frequency is valid. Positive frequency = forward run; negative frequency = reverse run. Direction can not be switched by digital keypad or external teriminal control.

Pr.03-11 Analog Input Gain (AVI) = 111.1%  
 $10/9 = 111.1\%$

21.

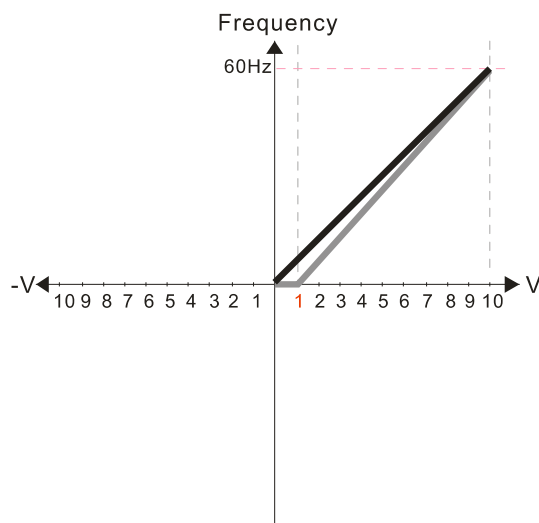

Pr.03-03=10%

Pr.03-07~03-09 (Positive/Negative Bias Mode)

- 0: No bias
- 1: Lower than or equal to bias
- 2: Greater than or equal to bias
- 3: The absolute value of the bias voltage while serving as the center
- 4: Serve bias as the center

Pr.03-10 (Analog Frequency Command for Reverse Run)

0: Negative frequency is not valid. Forward and reverse run is controlled by digital keypad or external terminal.

- 1: Neagtive frequency is valid. Positive frequency = forward run; negative frequency = reverse run. Direction can not be switched by digital keypad or external teriminal control.

Pr.03-11 Analog Input Gain (AVI) = 111.1%  
 $10/9 = 111.1\%$

22.

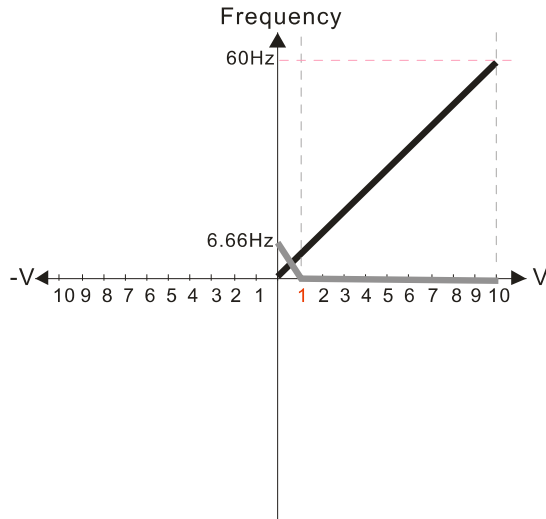

Pr.03-03=10%

Pr.03-07~03-09 (Positive/Negative Bias Mode)

- 0: No bias
- 1: Lower than or equal to bias
- 2: Greater than or equal to bias
- 3: The absolute value of the bias voltage while serving as the center
- 4: Serve bias as the center

Pr.03-10 (Analog Frequency Command for Reverse Run)

- 0: Negative frequency is not valid. Forward and reverse run is controlled by digital keypad or external terminal.
- 1: Negative frequency is valid. Positive frequency = forward run; negative frequency = reverse run. Direction can not be switched by digital keypad or external terminal control.

Pr03-11 Analog Input Gain (AVI) = 111.1%  
10/9 = 111.1%

23.

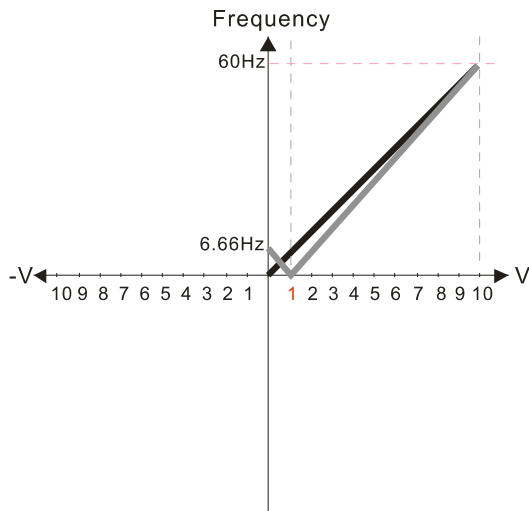

Pr.03-03=10%

Pr.03-07~03-09 (Positive/Negative Bias Mode)

- 0: No bias
- 1: Lower than or equal to bias
- 2: Greater than or equal to bias
- 3: The absolute value of the bias voltage while serving as the center
- 4: Serve bias as the center

Pr.03-10 (Analog Frequency Command for Reverse Run)

- 0: Negative frequency is not valid. Forward and reverse run is controlled by digital keypad or external terminal.
- 1: Negative frequency is valid. Positive frequency = forward run; negative frequency = reverse run. Direction can not be switched by digital keypad or external terminal control.

Pr.03-11 Analog Input Gain (AVI) = 111.1%  
10/9 = 111.1%

24.

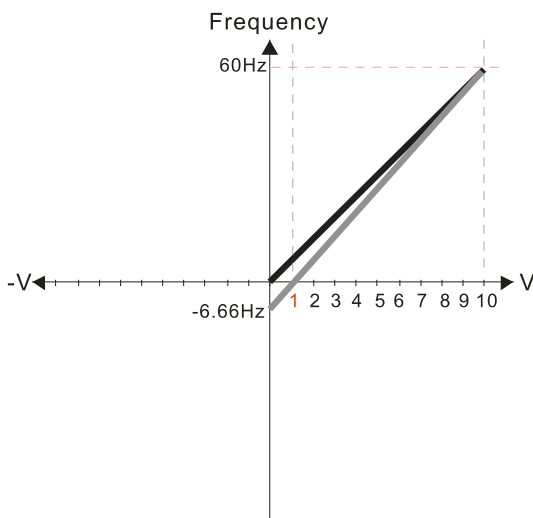

Pr.03-03=10%

Pr.03-07~03-09 (Positive/Negative Bias Mode)

- 0: No bias
- 1: Lower than or equal to bias
- 2: Greater than or equal to bias
- 3: The absolute value of the bias voltage while serving as the center
- 4: Serve bias as the center

Pr.03-10 (Analog Frequency Command for Reverse Run)

- 0: Negative frequency is not valid. Forward and reverse run is controlled by digital keypad or external terminal.
- 1: Negative frequency is valid. Positive frequency = forward run; negative frequency = reverse run. Direction can not be switched by digital keypad or external terminal control.

Pr.03-11 Analog Input Gain (AVI) = 100%  
10/9 = 111.1%

25.

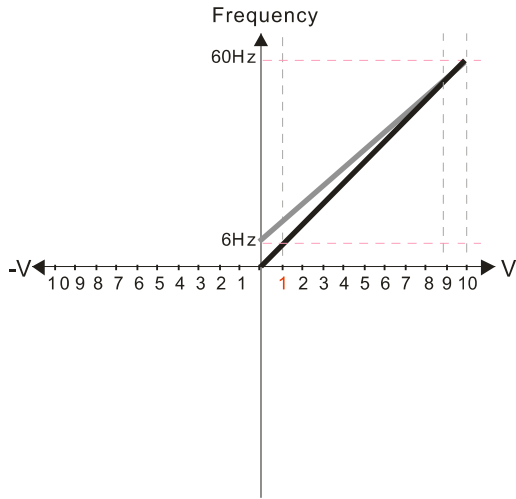

Pr.03-07~03-09 (Positive/Negative Bias Mode)

- 0: No bias
- 1: Lower than or equal to bias**
- 2: Greater than or equal to bias
- 3: The absolute value of the bias voltage while serving as the center
- 4: Serve bias as the center

Pr.03-10 (Analog Frequency Command for Reverse Run)

- 0: Negative frequency is not valid. Forward and reverse run is controlled by digital keypad or external terminal.**
- 1: Neagitive frequency is valid. Positive frequency = forward run; negative frequency = reverse run. Direction can not be switched by digital keypad or external terminal control.

Calculate the bias:

$$\frac{60-6\text{Hz}}{10\text{V}} = \frac{6-0\text{Hz}}{(0-x\text{V})} \quad x\text{V} = \frac{10}{-9} = -1.11\text{V} \quad \therefore 03-03 = \frac{-1.11}{10} \times 100\% = -11.1\%$$

$$\text{Calculate the gain: } 03-11 = \frac{10\text{V}}{11.1\text{V}} \times 100\% = 90.0\%$$

26.

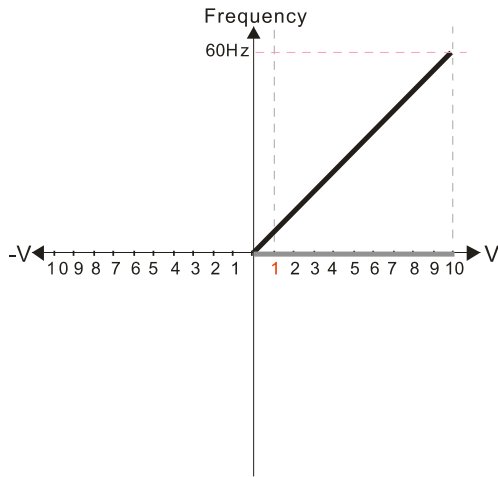

Pr.03-07~03-09 (Positive/Negative Bias Mode)

- 0: No bias
- 1: Lower than or equal to bias
- 2: Greater than or equal to bias**
- 3: The absolute value of the bias voltage while serving as the center
- 4: Serve bias as the center

Pr.03-10 (Analog Frequency Command for Reverse Run)

- 0: Negative frequency is not valid. Forward and reverse run is controlled by digital keypad or external terminal.**
- 1: Neagitive frequency is valid. Positive frequency = forward run; negative frequency = reverse run. Direction can not be switched by digital keypad or external terminal control.

Calculate the bias:

$$\frac{60-6\text{Hz}}{10\text{V}} = \frac{6-0\text{Hz}}{(0-x\text{V})} \quad x\text{V} = \frac{10}{-9} = -1.11\text{V} \quad \therefore 03-03 = \frac{-1.11}{10} \times 100\% = -11.1\%$$

$$\text{Calculate the gain: } 03-11 = \frac{10\text{V}}{11.1\text{V}} \times 100\% = 90.0\%$$

27.

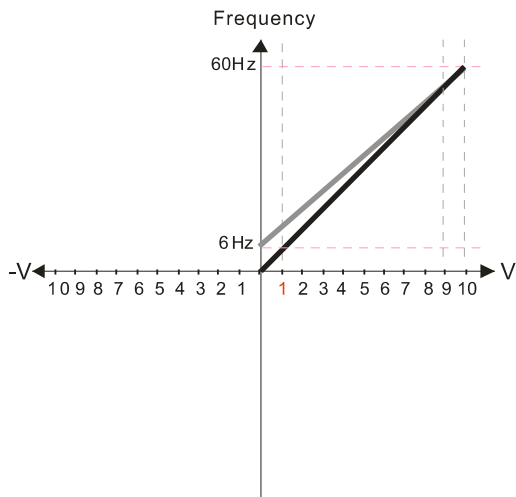

Pr.03-07~03-09 (Positive/Negative Bias Mode)

- 0: No bias
- 1: Lower than or equal to bias
- 2: Greater than or equal to bias
- 3: The absolute value of the bias voltage while serving as the center**
- 4: Serve bias as the center

Pr.03-10 (Analog Frequency Command for Reverse Run)

- 0: Negative frequency is not valid. Forward and reverse run is controlled by digital keypad or external terminal.**
- 1: Neagitive frequency is valid. Positive frequency = forward run; negative frequency = reverse run. Direction can not be switched by digital keypad or external terminal control.

Calculate the bias:

$$\frac{60-6\text{Hz}}{10\text{V}} = \frac{6-0\text{Hz}}{(0-x\text{V})} \quad x\text{V} = \frac{10}{-9} = -1.11\text{V} \quad \therefore 03-03 = \frac{-1.11}{10} \times 100\% = -11.1\%$$

$$\text{Calculate the gain: } 03-11 = \frac{10\text{V}}{11.1\text{V}} \times 100\% = 90.0\%$$

28.

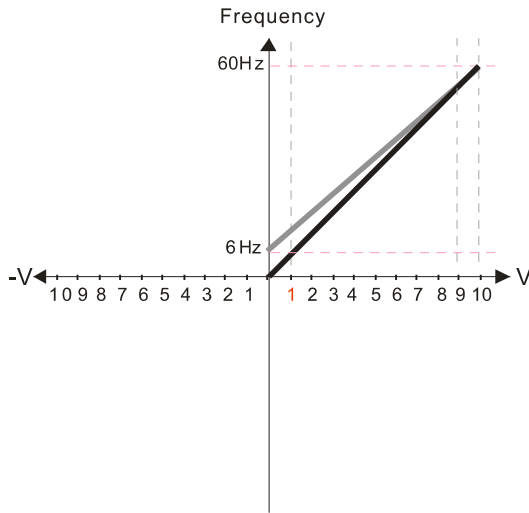

Pr.03-07~03-09 (Positive/Negative Bias Mode)

- 0: No bias
- 1: Lower than or equal to bias
- 2: Greater than or equal to bias
- 3: The absolute value of the bias voltage while serving as the center
- 4: Serve bias as the center

Pr.03-10 (Analog Frequency Command for Reverse Run)

0: Negative frequency is not valid. Forward and reverse run is controlled by digital keypad or external terminal.

- 1: Negative frequency is valid. Positive frequency = forward run; negative frequency = reverse run. Direction can not be switched by digital keypad or external terminal control.

Calculate the bias:

$$\frac{60-6\text{Hz}}{10\text{V}} = \frac{6-0\text{Hz}}{(0-x\text{V})} \quad x\text{V} = \frac{10}{-9} = -1.11\text{V} \quad \therefore 03-03 = \frac{-1.11}{10} \times 100\% = -11.1\%$$

Calculate the gain:  $03-11 = \frac{10\text{V}}{11.1\text{V}} \times 100\% = 90.0\%$

29.

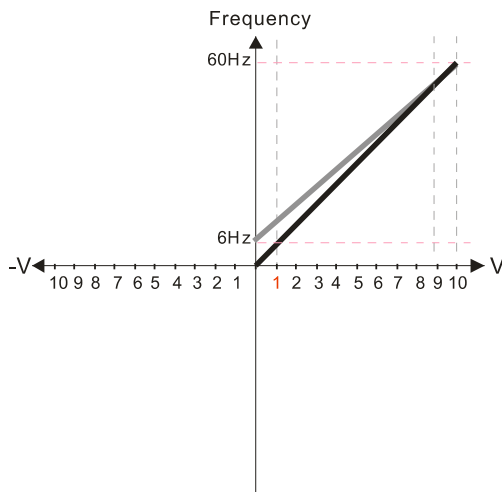

Pr.03-07~03-09 (Positive/Negative Bias Mode)

- 0: No bias
- 1: Lower than or equal to bias
- 2: Greater than or equal to bias
- 3: The absolute value of the bias voltage while serving as the center
- 4: Serve bias as the center

Pr.03-10 (Analog Frequency Command for Reverse Run)

0: Negative frequency is not valid. Forward and reverse run is controlled by digital keypad or external terminal.

- 1: Negative frequency is valid. Positive frequency = forward run; negative frequency = reverse run. Direction can not be switched by digital keypad or external terminal control.

Calculate the bias:

$$\frac{60-6\text{Hz}}{10\text{V}} = \frac{6-0\text{Hz}}{(0-x\text{V})} \quad x\text{V} = \frac{10}{-9} = -1.11\text{V} \quad \therefore 03-03 = \frac{-1.11}{10} \times 100\% = -11.1\%$$

Calculate the gain:  $03-11 = \frac{10\text{V}}{11.1\text{V}} \times 100\% = 90.0\%$

30.

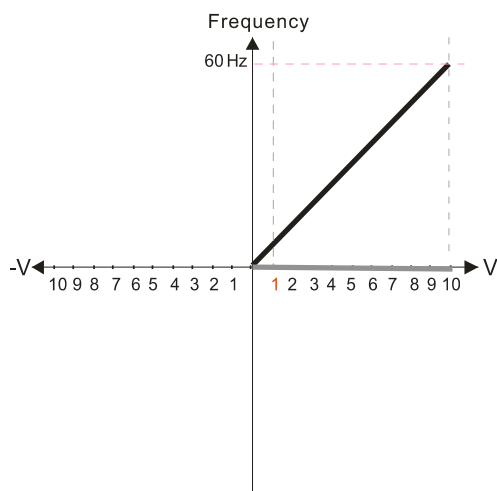

Pr.03-07~03-09 (Positive/Negative Bias Mode)

- 0: No bias
- 1: Lower than or equal to bias
- 2: Greater than or equal to bias
- 3: The absolute value of the bias voltage while serving as the center
- 4: Serve bias as the center

Pr.03-10 (Analog Frequency Command for Reverse Run)

0: Negative frequency is not valid. Forward and reverse run is controlled by digital keypad or external terminal.

- 1: Negative frequency is valid. Positive frequency = forward run; negative frequency = reverse run. Direction can not be switched by digital keypad or external terminal control.

Calculate the bias:

$$\frac{60-6\text{Hz}}{10\text{V}} = \frac{6-0\text{Hz}}{(0-x\text{V})} \quad x\text{V} = \frac{10}{-9} = -1.11\text{V} \quad \therefore 03-03 = \frac{-1.11}{10} \times 100\% = -11.1\%$$

Calculate the gain:  $03-11 = \frac{10\text{V}}{11.1\text{V}} \times 100\% = 90.0\%$

31.

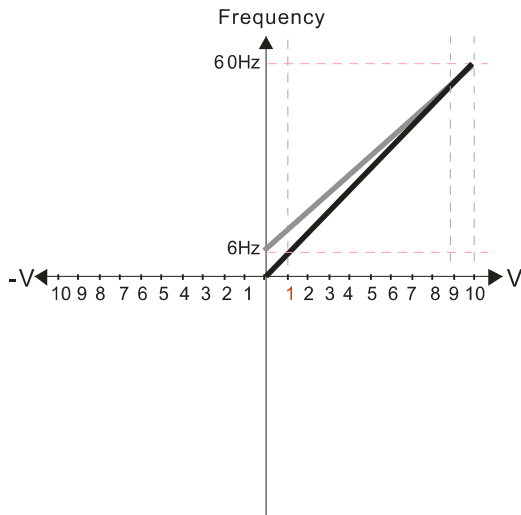

- Pr.03-07~03-09 (Positive/Negative Bias Mode)
- 0: No bias
  - 1: Lower than or equal to bias
  - 2: Greater than or equal to bias
  - 3: The absolute value of the bias voltage while serving as the center
  - 4: Serve bias as the center

- Pr.03-10 (Analog Frequency Command for Reverse Run)
- 0: Negative frequency is not valid. Forward and reverse run is controlled by digital keypad or external terminal.
  - 1: Neagitive frequency is valid. Positive frequency = forward run; negative frequency = reverse run. Direction can not be switched by digital keypad or external teriminal control.

Calculate the bias:

$$\frac{60-6\text{Hz}}{10\text{V}} = \frac{6-0\text{Hz}}{(0-x\text{V})} \quad x\text{V} = \frac{10}{-9} = -1.11\text{V} \quad \therefore 03-03 = \frac{-1.11}{10} \times 100\% = -11.1\%$$

Calculate the gain:  $03-11 = \frac{10\text{V}}{11.1\text{V}} \times 100\% = 90.0\%$

32.

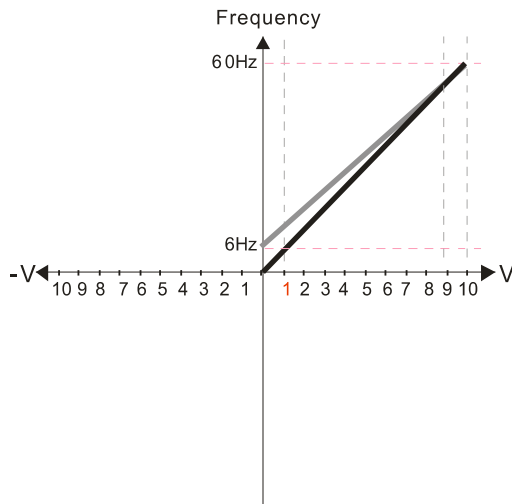

- Pr.03-07~03-09 (Positive/Negative Bias Mode)
- 0: No bias
  - 1: Lower than or equal to bias
  - 2: Greater than or equal to bias
  - 3: The absolute value of the bias voltage while serving as the center
  - 4: Serve bias as the center

- Pr.03-10 (Analog Frequency Command for Reverse Run)
- 0: Negative frequency is not valid. Forward and reverse run is controlled by digital keypad or external terminal.
  - 1: Neagitive frequency is valid. Positive frequency = forward run; negative frequency = reverse run. Direction can not be switched by digital keypad or external teriminal control.

Calculate the bias:

$$\frac{60-6\text{Hz}}{10\text{V}} = \frac{6-0\text{Hz}}{(0-x\text{V})} \quad x\text{V} = \frac{10}{-9} = -1.11\text{V} \quad \therefore 03-03 = \frac{-1.11}{10} \times 100\% = -11.1\%$$

Calculate the gain:  $03-11 = \frac{10\text{V}}{11.1\text{V}} \times 100\% = 90.0\%$

33.

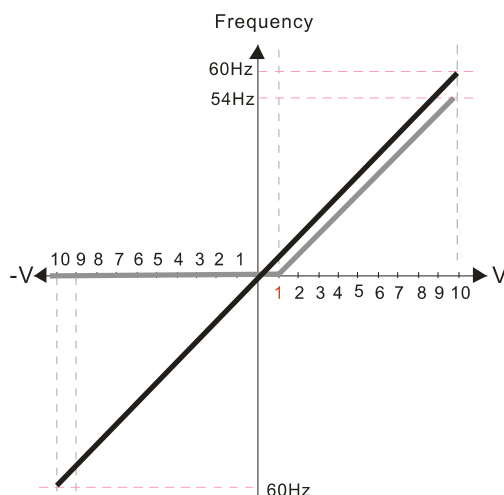

- Pr.00-21=0 (Digital keypad control and run in FWD direction)
- Pr.03-05 Analog Positive Voltage Input Bias (AUI) = 10%
- Pr.03-07~03-09 (Positive/Negative Bias Mode)
- 0: No bias
  - 1: Lower than or equal to bias
  - 2: Greater than or equal to bias
  - 3: The absolute value of the bias voltage while serving as the center
  - 4: Serve bias as the center

- Pr.03-13 Analog Positive Input Gain (AUI) = 100%
- Pr.03-14 Analog Positive Input Gain (AUI) = 100%

34.

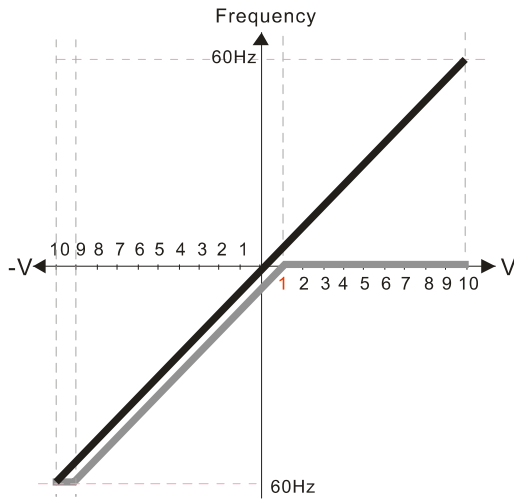

Pr.00-21=0 (Digital keypad control and run in FWD direction)  
 Pr.03-05 Analog Positive Voltage Input Bias (AUI) = 10%  
 Pr.03-07~03-09 (Positive/Negative Bias Mode)  
 0: No bias  
 1: Lower than or equal to bias  
 2: **Greater than or equal to bias**  
 3: The absolute value of the bias voltage while serving as the center  
 4: Serve bias as the center

Pr.03-13 Analog Positive Input Gain (AUI) = 100%  
 Pr.03-14 Analog Positive Input Gain (AUI) = 100%

35.

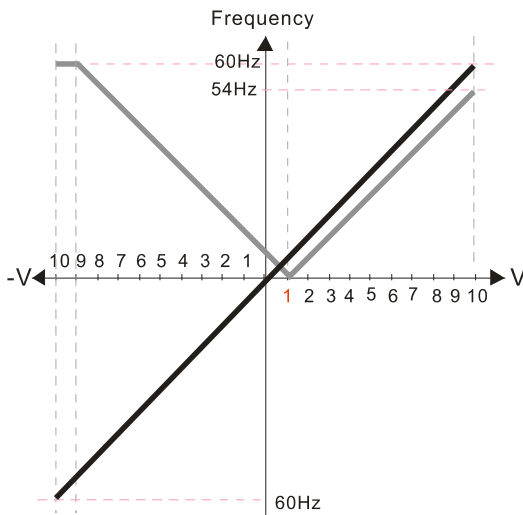

Pr.00-21=0 (Digital keypad control and run in FWD direction)  
 Pr.03-05 Analog Positive Voltage Input Bias (AUI) = 10%  
 Pr.03-07~03-09 (Positive/Negative Bias Mode)  
 0: No bias  
 1: Lower than or equal to bias  
 2: Greater than or equal to bias  
 3: **The absolute value of the bias voltage while serving as the center**  
 4: Serve bias as the center

Pr.03-13 Analog Positive Input Gain (AUI) = 100%  
 Pr.03-14 Analog Positive Input Gain (AUI) = 100%

36.

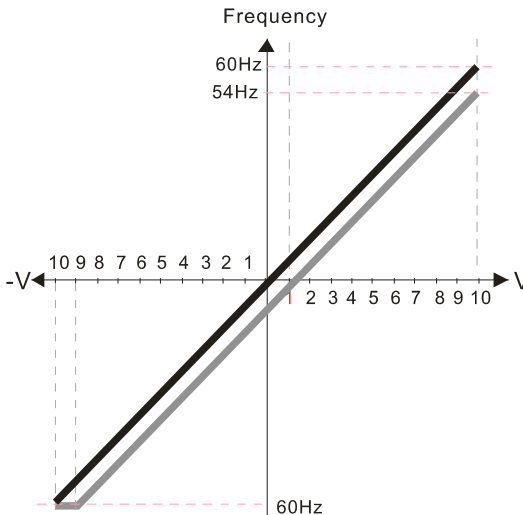

Pr.00-21=0 (Digital keypad control and run in FWD direction)  
 Pr.03-05 Analog Positive Voltage Input Bias (AUI) = 10%  
 Pr.03-07~03-09 (Positive/Negative Bias Mode)  
 0: No bias  
 1: Lower than or equal to bias  
 2: Greater than or equal to bias  
 3: The absolute value of the bias voltage while serving as the center  
 4: **Serve bias as the center**

Pr.03-13 Analog Positive Input Gain (AUI) = 100%  
 Pr.03-14 Analog Positive Input Gain (AUI) = 100%



37.

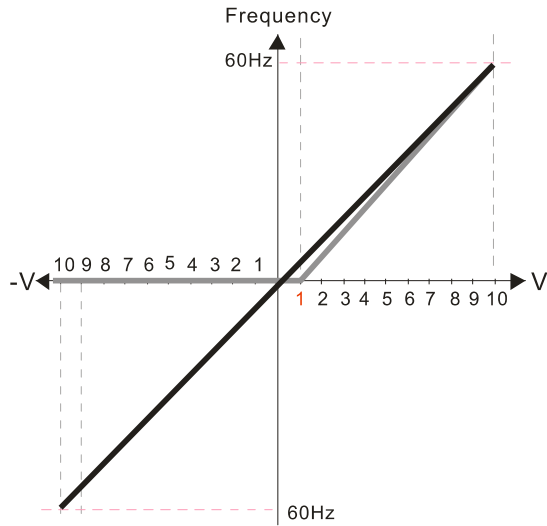

Pr.00-21=0 (Digital keypad control and run in FWD direction)  
 Pr.03-05 Analog Positive Voltage Input Bias (AUI) = 10%  
 Pr.03-07~03-09 (Positive/Negative Bias Mode)  
 0: No bias  
 1: Lower than or equal to bias  
 2: Greater than or equal to bias  
 3: The absolute value of the bias voltage while serving as the center  
 4: Serve bias as the center

Pr.03-13 Analog Positive Input Gain (AUI) = 111.1%  
 $(10/9) * 100\% = 111.1\%$   
 Pr.03-14 Analog Positive Input Gain (AUI) = 100%

38.

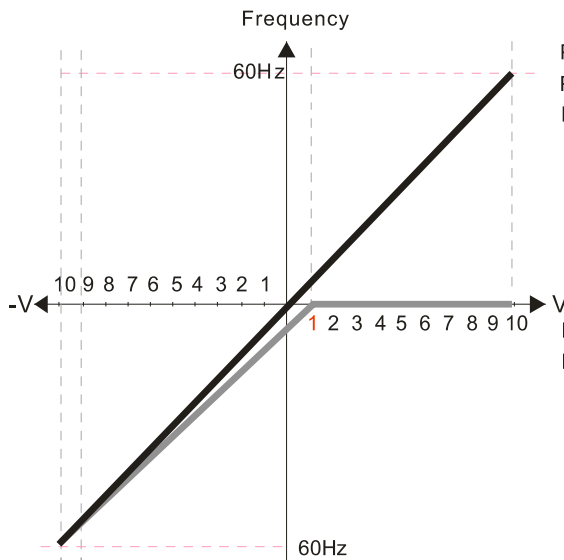

Pr.00-21=0 (Digital keypad control and run in FWD direction)  
 Pr.03-05 Analog Positive Voltage Input Bias (AUI) = 10%  
 Pr.03-07~03-09 (Positive/Negative Bias Mode)  
 0: No bias  
 1: Lower than or equal to bias  
 2: Greater than or equal to bias  
 3: The absolute value of the bias voltage while serving as the center  
 4: Serve bias as the center

Pr.03-13 Analog Positive Input Gain (AUI) = 100%  
 Pr.03-14 Analog Positive Input Gain (AUI) = 90.0%  
 $(10/11) * 100\% = 90.9\%$

39.

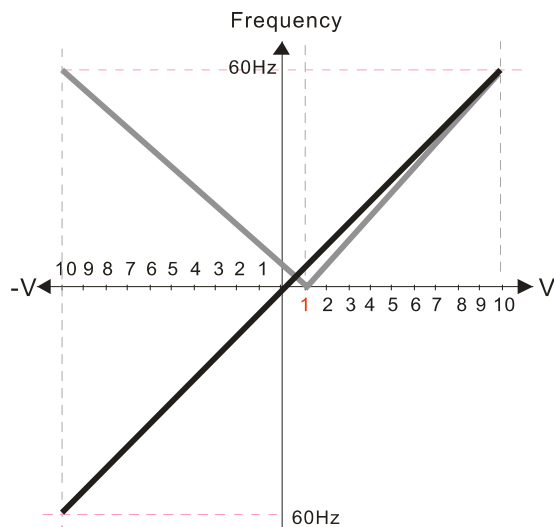

Pr.00-21=0 (Digital keypad control and run in FWD direction)  
 Pr.03-05 Analog Positive Voltage Input Bias (AUI) = 10%  
 Pr.03-07~03-09 (Positive/Negative Bias Mode)  
 0: No bias  
 1: Lower than or equal to bias  
 2: Greater than or equal to bias  
 3: The absolute value of the bias voltage while serving as the center  
 4: Serve bias as the center

Pr.03-13 Analog Positive Input Gain (AUI) = 111.1%  
 $(10/9) * 100\% = 111.1\%$   
 Pr.03-14 Analog Positive Input Gain (AUI) = 90.0%  
 $(10/11) * 100\% = 90.9\%$

40.

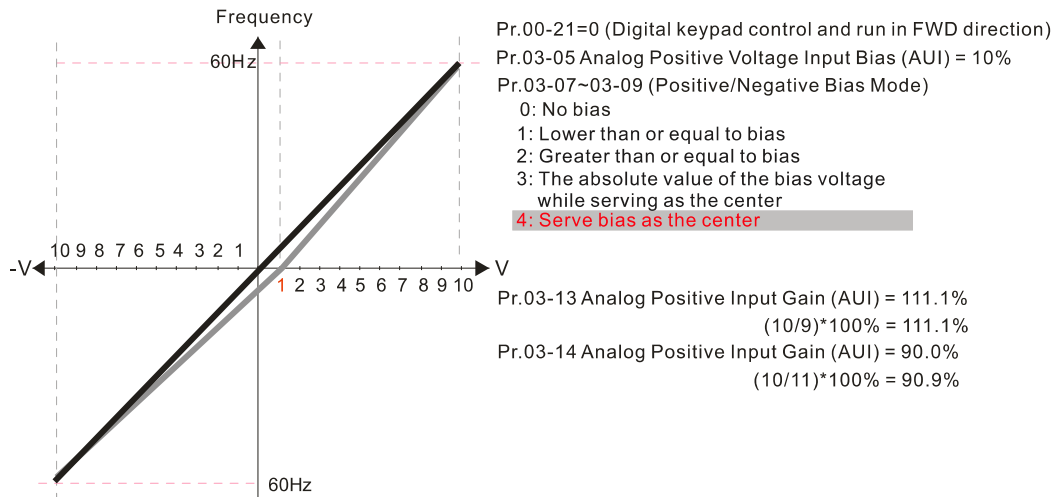

➤ **03-10** Reverse Setting when Analog Signal Input is Negative Frequency Default: 0

- Settings 0: Negative frequency is not allowed. The digital keypad or external terminal controls the forward and reverse direction.
- 1: Negative frequency is allowed. Positive frequency = run in forward direction; negative frequency = run in reverse direction. The digital keypad or external terminal control cannot switch the running direction.

📖 Use Pr.03-10 to enable running in the reverse direction command when a negative frequency (negative bias and gain) is input to the AVI or ACI analog signal input (except AUI).

📖 Condition for negative frequency (reverse)

1. Pr. 03-10 = 1
2. Bias mode = Serve bias as the center
3. Corresponded analog input gain < 0 (negative); this makes the input frequency negative.

📖 In using the additional analog input function (Pr. 03-18 = 1), when analog signal is negative after the addition, you can set this parameter to allow or not allow the reverse direction. The result after adding is restricted by the “Condition for negative frequency (reverse)”.

➤ **03-11** Analog Input Gain (AVI)

➤ **03-12** Analog Input Gain (ACI)

➤ **03-13** Analog Positive Input Gain (AUI)

➤ **03-14** Analog Negative Input Gain (AUI)

Default: 100.0

Settings -500.0–500.0 %

📖 Use Pr. 03-03–Pr. 03-14 when the frequency command source is the analog voltage or current signal.

➤ **03-15** Analog Input Filter Time (AVI)

➤ **03-16** Analog Input Filter Time (ACI)

➤ **03-17** Analog Input Filter Time (AUI)

Default: 0.01

Settings 0.00–20.00 sec.

- 📖 There is often noisy in the analog signal from AVI, ACI and AUI, which affects the stability of the control. Use these input delays to filter a noisy analog signal.
- 📖 When the time constant setting is too large, the control is stable but the control response is slow. When the time constant setting is too small, the control response is faster but the control may be unstable. For optimal setting, adjust the setting based on the control stability or the control response.

↗ **03-18** Analog Input Addition Function

Default: 0

Settings 0: Disable (AVI, ACI, AUI)  
1: Enable

- 📖 When Pr. 03-18 is set to 1:  
EX1: Pr. 03-00 = Pr. 03-01=1, Frequency command= AVI+ACI  
EX2: Pr. 03-00 = Pr. 03-01 = Pr. 03-02 = 1, Frequency command = AVI+ACI+AUI  
EX3: Pr. 03-00 = Pr. 03-02=1, Frequency command = AVI+AUI  
EX4: Pr. 03-01 = Pr. 03-02=1, Frequency command = ACI+AUI
- 📖 When Pr. 03-18 is set to 0 and the analog input setting is the same, the priority for AVI, ACI and AUI are AVI > ACI > AUI.

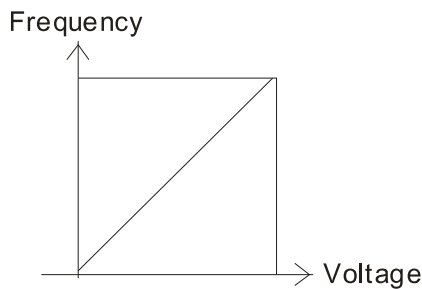

$$F_{cmd} = [(ay \pm bias) * gain] * \frac{F_{max}(01-00)}{10V \text{ or } 16mA \text{ or } 20mA}$$

Fcmd: the corresponding frequency of 10V or 20mA  
 ay : 0~10V, 4~20mA, 0~20mA  
 bias : Pr.03-03, Pr. 03-04, Pr.03-05  
 gain : Pr.03-11, Pr.03-12, Pr.03-13, Pr.03-14

↗ **03-19** Signal Loss Selection for Analog Input 4–20 mA

Default: 0

Settings 0: Disable  
1: Continue operation at the last frequency  
2: Decelerate to 0 Hz  
3: Stop immediately and display ACE

- 📖 Determines the response when the 4–20mA signal is lost, when AVIc (Pr. 03-28 = 2) or ACIc (Pr. 03-29 = 0).
- 📖 When Pr. 03-28 is not set to 2, the voltage input to AVI terminal is 0–10V or 0–20mA, and the Pr. 03-19 is invalid.
- 📖 When Pr. 03-29 is not set to 0, the voltage input to ACI terminal is 0–10V or 0–20mA, and the Pr. 03-19 is invalid.
- 📖 When the setting is 1 or 2, the keypad displays the warning code “ANL”. It keeps blinking until the ACI signal is recovered.
- 📖 When the motor drive stops, the warning condition does not continue to exist, so the warning disappears.

↗ **03-20** Multi-function Output 1 (AFM1)

Default: 0

↗ **03-23** Multi-function Output 2 (AFM2)

Default: 0

Settings 0–25

#### Function Chart

Settings	Functions	Descriptions
0	Output frequency (Hz)	Maximum frequency Pr. 01-00 is regarded as 100%.
1	Frequency command (Hz)	Maximum frequency Pr. 01-00 is regarded as 100%.
2	Motor speed (Hz)	Maximum frequency Pr. 01-00 is regarded as 100%.
3	Output current (rms)	(2.5 X rated current) is regarded as 100%
4	Output voltage	(2 X rated voltage) is regarded as 100%
5	DC BUS Voltage	450 V (900 V)=100%
6	Power factor	-1.000–1.000=100%
7	Power	(2 X rated power) is regarded as 100%
8	Output torque	Full-load torque is regarded as 100%
9	AVI	0–10V = 0–100%
10	ACI	4–20mA = 0–100%
11	AUI	-10–10V=0–100%
12	Iq current command	(2.5 X rated current) is regarded as 100%
13	Iq feedback value	(2.5 X rated current) is regarded as 100%
14	Id current command	(2.5 X rated current) is regarded as 100%
15	Id feedback value	(2.5 X rated current) is regarded as 100%
18	Torque command	Rated torque is regarded as 100%
19	PG2 frequency command	Maximum frequency Pr. 01-00 is regarded as 100%.
20	CANopen analog output	CANopen communication analog output
21	RS-485 analog output	For RS-485 (InnerCOM / MODBUS) control output
22	Communication card analog output	Communication analog output (CMC-MOD01, CMC-EIP01, CMC-PN01, CMC-DN01)
23	Constant voltage output	Pr. 03-32 and Pr. 03-33 control voltage output level. 0–100 % of Pr. 03-32 corresponds to 0–10 V of AFM1.
25	CANopen and RS-485 analog output	For CANopen and InnerCOM control output

↗ **03-21** Analog Output Gain 1 (AFM1)

Default: 100.0

↗ **03-24** Analog Output Gain 2 (AFM2)

Default: 100.0

Settings 0.0–500.0 %

📖 Adjusts the voltage level outputted to the analog meter from the analog signal (Pr.03-20) output terminal AFM of the drive.

➤ **03-22** Analog Output 1 in REV Direction (AFM1) Default: 0

➤ **03-25** Analog Output 2 in REV Direction (AFM2) Default: 0

- Settings
- 0: Absolute value of output voltage
  - 1: Reverse output 0 V; forward output 0–10 V
  - 2: Reverse output 5–0 V; forward output 5–10 V

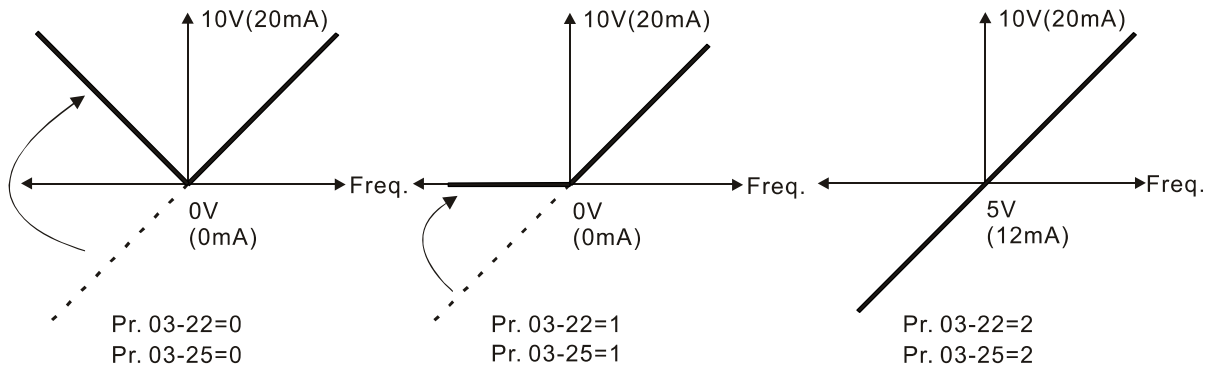

Selections for the analog output direction

➤ **03-27** AFM2 Output Bias Default: 0.00

- Settings -100.00–100.00 %

- 📖 Example 1, AFM2 0–10V is set to the output frequency, the output equation is:  
 $10V * (\text{output frequency} / \text{Pr. 01-00}) * \text{Pr. 03-24} + 10V * \text{Pr. 03-27}$
- 📖 Example 2, AFM2 0–20mA is set to the output frequency, the output equation is:  
 $20mA * (\text{output frequency} / \text{Pr. 01-00}) * \text{Pr. 03-24} + 20mA * \text{Pr. 03-27}$
- 📖 Example 3, AFM2 4–20mA is set to the output frequency, the output equation is:  
 $4mA + 16mA * (\text{output frequency} / \text{Pr. 01-00}) * \text{Pr. 03-24} + 16mA * \text{Pr. 03-27}$
- 📖 This parameter sets the corresponding voltage for the analog output 0.

➤ **03-28** AVI Terminal Input Selection Default: 0

- Settings
- 0: 0–10V
  - 1: 0–20mA
  - 2: 4–20mA

➤ **03-29** ACI Terminal Input Selection Default: 0

- Settings
- 0: 4–20mA
  - 1: 0–10V
  - 2: 0–20mA

- 📖 When you change the input mode, verify that the external terminal switch (SW3, SW4) corresponds to the setting for Pr. 03-28–Pr. 03-29.

**03-30** PLC Analog Output Terminal Status

Default: Read only

Settings Monitor the status of PLC analog output terminals

Pr. 03-30 displays the external multi-function output terminal that used by PLC.

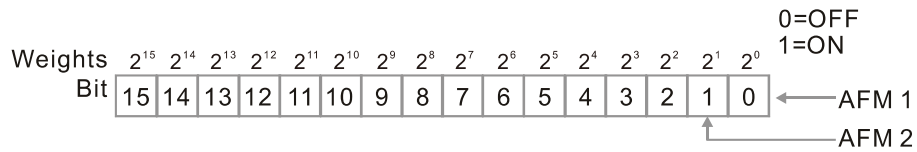

NOTE  
 $2^7=128$      $2^6=64$   
 $2^5=32$      $2^4=16$      $2^3=8$   
 $2^2=4$      $2^1=2$      $2^0=1$

For Example:

When Pr. 03-30 displays 0002h (hex), it means that AFM2 is used by PLC.

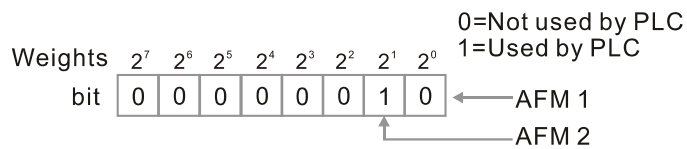

Display value  
 $2 = 1 \times 2^1 + 0 \times 2^0$   
 $= \text{bit } 1 \times 2^1 + \text{bit } 0 \times 2^0$

**03-31** AFM2 Output Selection

Default: 0

Settings 0: 0–20mA output  
 1: 4–20mA output

**03-32** AFM1 DC Output Setting Level

**03-33** AFM2 DC Output Setting Level

Default: 0.00

Settings 0.00–100.00 %

**03-35** AFM1 Filter Output Time

**03-36** AFM2 Filter Output Time

Default: 0.01

Settings 0.00–20.00 sec.

**03-44** Multi-function MO Output by AI Level Source

Default: 0

Settings 0: AVI  
 1: ACI  
 2: AUI

**03-45** AI Upper Level

Default: 50.00

Settings -100.00–100.00 %

↗ **03-46** AI Lower Level

Default: 10.00

Settings -100.00–100.00 %

- 📖 Multi-function output terminal 67 must work with Pr.03-44 to select input channels. When analog input level is higher than Pr.03-45, multi-function output acts; when analog input level is lower than Pr.03-46, multi-function output terminals stop outputting.
- 📖 When setting levels, AI upper level must be higher than AI lower level.

↗ **03-50** Analog Input Curve Selection

Default: 0

- Settings
- 0: Regular Curve
  - 1: Three-point curve of AVI
  - 2: Three-point curve of ACI
  - 3: Three-point curve of AVI & ACI
  - 4: Three-point curve of AUI
  - 5: Three-point curve of AVI & AUI
  - 6: Three-point curve of ACI & AUI
  - 7: Three-point curve of AVI & ACI & AUI

- 📖 Sets the calculation method for analog input.
- 📖 When Pr. 03-50 = 0, all analog input signal is calculated by bias and gain.
- 📖 When Pr. 03-50 = 1, AVI calculates by frequency and voltage / current (Pr. 03-51–03-56), other analog input signal calculates by bias and gain.
- 📖 When Pr. 03-50 = 2, ACI calculates by frequency and voltage / current (Pr. 03-57–03-62), other analog input signal calculates by bias and gain.
- 📖 When Pr. 03-50 = 3, AVI and ACI calculate by frequency and voltage/ current (Pr. 03-51–03-62), other analog input signal calculates by bias and gain.
- 📖 When Pr. 03-50 = 4, AVI calculates by frequency and voltage / current (Pr. 03-63–03-74), other analog input signal calculates by bias and gain.
- 📖 When Pr. 03-50 = 5, AVI and AUI calculate by frequency and voltage / current (Pr. 03-51–03-56 and 03-63–03-74), other analog input signal calculates by bias and gain.
- 📖 When Pr. 03-50 = 6, ACI and AVI calculate by frequency and voltage / current (Pr. 03-57–03-74), other analog input signal calculates by bias and gain.
- 📖 When Pr. 03-50 = 7, all analog input signal calculate by frequency and voltage / current (Pr. 03-51–03-74).

↗ **03-51** AVI Lowest Point

Default:  
0.00 / 0.00 / 4.00

- Settings
- Pr. 03-28 = 0, 0.00–10.00V
  - Pr. 03-28 = 1, 0.00–20.00mA
  - Pr. 03-28 = 2, 0.00–20.00mA

↗ <b>03-52</b>	AVI Proportional Lowest Point	Default: 0.00
	Settings -100.00–100.00 %	
↗ <b>03-53</b>	AVI Mid-Point	Default: 5.00 / 10.00 / 12.00
	Settings Pr. 03-28 = 0, 0.00–10.00 V Pr. 03-28 = 1, 0.00–20.00 mA Pr. 03-28 = 2, 0.00–20.00 mA	
↗ <b>03-54</b>	AVI Proportional Mid-Point	Default: 50.00
	Settings -100.00–100.00 %	
↗ <b>03-55</b>	AVI Highest Point	Default: 10.00 / 20.00 / 20.00
	Settings Pr. 03-28 = 0, 0.00–10.00 V Pr. 03-28 = 1, 0.00–20.00 mA Pr. 03-28 = 2, 0.00–20.00 mA	
↗ <b>03-56</b>	AVI Proportional High Point	Default: 100.00
	Settings -100.00–100.00 %	

- 📖 When Pr. 03-28 = 0, AVI setting is 0–10 V and the unit is in voltage (V).
- 📖 When Pr. 03-28 ≠ 0, AVI setting is 0–20 mA or 4–20 mA and the unit is in current (mA).
- 📖 When you set the analog input AVI to frequency command, 100% corresponds to Fmax (Pr. 01-00 maximum operation frequency).
- 📖 The requirement for these three parameters (Pr. 03-51, Pr. 03-53 and Pr. 03-55) is Pr. 03-51 < Pr. 03-53 < Pr. 03-55. The values for three proportional points (Pr. 03-52, Pr. 03-54 and Pr. 03-56) have no limits. Values between two points are calculated by a linear equation. The ACI and AUI are same as AVI.
- 📖 The output percentage 0% when the AVI input value is lower than the lowest point setting.  
Example: Pr. 03-51 = 1 V; Pr. 03-52 = 10 %. The output is 0 % when AVI input is lower than 1V. If the AVI input varies between 1V and 1.1V, the drive's output frequency is between 0% and 10%.

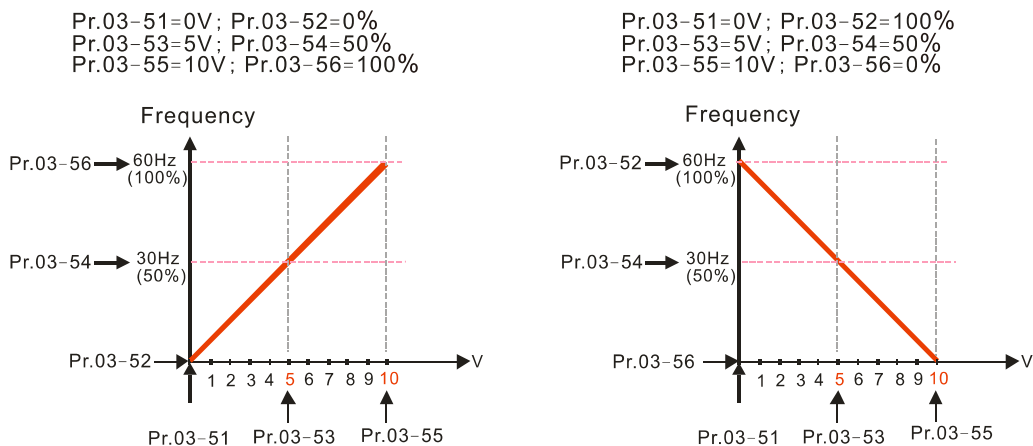



Pr.03-51=1V; Pr.03-52=10%  
 Pr.03-53=5V; Pr.03-54=50%  
 Pr.03-55=10V; Pr.03-56=100%

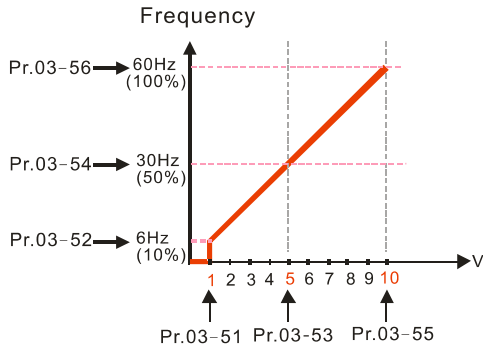

Pr.03-51=1V; Pr.03-52=10%  
 Pr.03-53=5V; Pr.03-54=50%  
 Pr.03-55=9V; Pr.03-56=100%

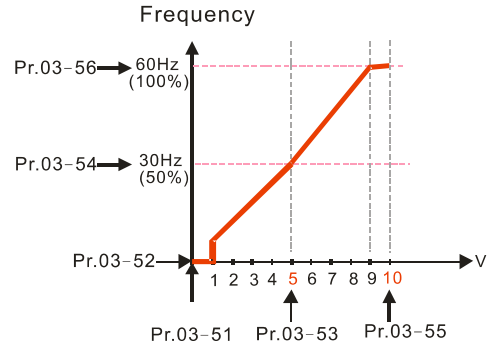

Pr.03-51=0V; Pr.03-52=10%  
 Pr.03-53=5V; Pr.03-54=50%  
 Pr.03-55=10V; Pr.03-56=100%

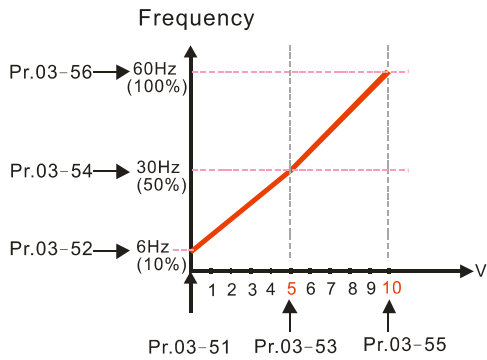

Pr.03-51=1V; Pr.03-52=0%  
 Pr.03-53=5V; Pr.03-54=50%  
 Pr.03-55=10V; Pr.03-56=100%

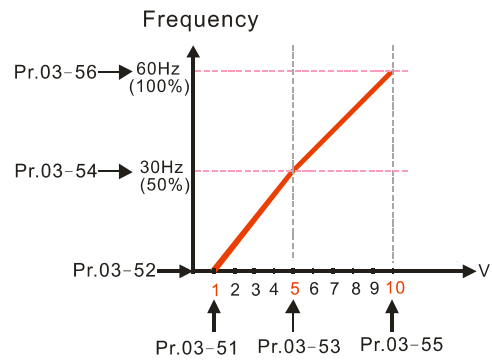

03-57 ACI Lowest Point

Default:  
 4.00 / 0.00 / 0.00

Settings Pr. 03-29 = 0, 0.00–20.0 mA  
 Pr. 03-29 = 1, 0.00–10.00 V  
 Pr. 03-29 = 2, 0.00–20.00 mA

03-58 ACI Proportional Low Point

Default: 0.00

Settings -100.00–100.00 %

03-59 ACI Mid-Point

Default:  
 12.00 / 5.00 / 10.00

Settings Pr. 03-29 = 0, 0.00–20.00 mA  
 Pr. 03-29 = 1, 0.00–10.00 V  
 Pr. 03-29 = 2, 0.00–20.00 mA

03-60 ACI Proportional Mid-Point

Default: 50.00

Settings -100.00–100.00 %

↗	<b>03-61</b>	ACI Highest Point	Default: 20.00 / 10.00 / 20.00
		Settings Pr. 03-29 = 0, 0.00–20.00mA Pr. 03-29 = 1, 0.00–10.00V Pr. 03-29 = 2, 0.00–20.00mA	
↗	<b>03-62</b>	ACI Proportional Highest Point	Default: 100.00
		Settings -100.00–100.00%	
		<p>📖 When Pr. 03-29 = 1, ACI setting is 0–10V and the unit is in voltage (V). When Pr. 03-29 ≠ 1, ACI setting is 0–20mA or 4–20mA and the unit is in current (mA).</p> <p>📖 When you set the analog input ACI to frequency command, 100% corresponds to Fmax (Pr. 01-00 maximum operation frequency).</p> <p>📖 The requirement for these three parameters (Pr. 03-57, Pr. 03-59 and Pr. 03-61) is Pr. 03-57 &lt; Pr. 03-59 &lt; Pr. 03-61. The values for three proportional points (Pr. 03-58, Pr. 03-60 and Pr. 03-62) have no limits. Values between two points are calculated by a linear equation.</p> <p>📖 The output percentage is 0% when the ACI input value is lower than the lowest point setting.</p> <p>Example: Pr. 03-57 = 2 mA; Pr. 03-58 = 10 %. The output becomes 0 % when AVI input is lower than 2 mA. If the ACI input varies between 2 mA and 2.1 mA, the drive's output frequency oscillates between 0 % and 10%.</p>	
↗	<b>03-63</b>	Positive AUI Voltage Lowest Point	Default: 0.00
		Settings 0.00–10.00 V	
↗	<b>03-64</b>	Positive AUI Voltage Proportional Lowest Point	Default: 0.00
		Settings -100.00–100.00 %	
↗	<b>03-65</b>	Positive AUI Voltage Mid-Point	Default: 5.00
		Settings 0.00–10.00 V	
↗	<b>03-66</b>	Positive AUI Voltage Proportional Mid-Point	Default: 50.00
		Settings -100.00–100.00 %	
↗	<b>03-67</b>	Positive AUI Voltage Highest Point	Default: 10.00
		Settings 0.00–10.00 V	
↗	<b>03-68</b>	Positive AUI Voltage Proportional Highest Point	Default: 100.00
		Settings -100.00–100.00 %	

📖 When you set the positive voltage AUI to the frequency command, 100% corresponds to Fmax (Pr. 01-00 maximum operation frequency) and the motor runs in the forward direction.

The requirement for these three parameters (Pr. 03-63, Pr. 03-65 and Pr. 03-67) is Pr. 03-63 < Pr. 03-65 < Pr. 03-67. The values for three proportional points (Pr. 03-64, Pr. 03-66 and Pr. 03-68) have no limits. Values between two points are calculated by a linear equation.

Positive AUI input voltage is lower than Low Point, output proportional is 0%.

For example:

Pr. 03-63 = 1V; Pr. 03-64 = 10%. The output will become 0% when the input is lower than 1V. If the AUI input varies between 1V and 1.1V, the drive's output frequency oscillates between 0% and 10%.

Pr. 03-51~03-68 is able to set the open circuit corresponding function of analog input value and max. operation frequency (Pr. 01-00), as shown in the figure below:

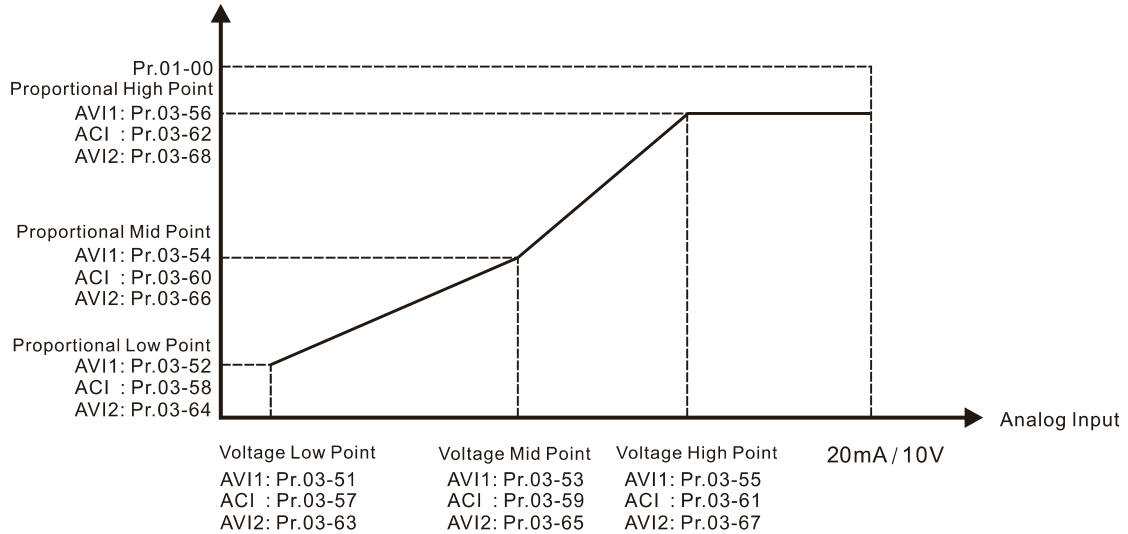

- 03-69** Negative AUI Voltage Highest Point Default: 0.00

Settings -10.00–0.00 V
- 03-70** Negative AUI Voltage Proportional Highest Point Default: 0.00

Settings -100.00–100.00 %
- 03-71** Negative AUI Voltage Mid-Point Default: -5.00



Settings -10.00–0.00 V
- 03-72** Negative AUI Voltage Proportional Mid-Point Default: -50.00

Settings -100.00–100.00 %
- 03-73** Negative AUI Voltage Lowest Point Default: -10.00

Settings -10.00–0.00 V
- 03-74** Negative AUI Voltage Proportional Lowest Point Default: -100.00

Settings -100.00–100.00 %

When you set the negative voltage AUI to frequency command, 100% corresponds to Fmax (Pr. 01-00 maximum operation frequency) and the motor runs in the reverse direction.

-  The requirement for these three parameters (Pr. 03-69, Pr. 03-71 and Pr. 03-73) is  $\text{Pr. 03-69} < \text{Pr. 03-71} < \text{Pr. 03-73}$ . The values for three proportional points (Pr. 03-70, Pr. 03-72 and Pr. 03-74) have not limits. Values between two points are calculated by a linear calculation.
-  The output % becomes 0% when the negative AUI input value is lower than the lowest point setting. For example:  
Pr. 03-69 = -1V; Pr. 03-70 = 10%, then the output becomes 0% when the AUI input is  $\geq -1\text{V}$ . If the AUI input varies between -1 V and -1.1 V, the drive's output frequency oscillates between 0% and 10%.

## 04 Multi-step Speed Parameters

✎ This parameter can be set during operation.

✎	<b>04-00</b>	1st Step Speed Frequency
✎	<b>04-01</b>	2nd Step Speed Frequency
✎	<b>04-02</b>	3rd Step Speed Frequency
✎	<b>04-03</b>	4th Step Speed Frequency
✎	<b>04-04</b>	5th Step Speed Frequency
✎	<b>04-05</b>	6th Step Speed Frequency
✎	<b>04-06</b>	7th Step Speed Frequency
✎	<b>04-07</b>	8th Step Speed Frequency
✎	<b>04-08</b>	9th Step Speed Frequency
✎	<b>04-09</b>	10th Step Speed Frequency
✎	<b>04-10</b>	11th Step Speed Frequency
✎	<b>04-11</b>	12th Step Speed Frequency
✎	<b>04-12</b>	13th Step Speed Frequency
✎	<b>04-13</b>	14th Step Speed Frequency
✎	<b>04-14</b>	15th Step Speed Frequency

Default: 0.00

Settings 0.00–599.00 Hz

📖 Use the multi-function input terminals (refer to settings 1–4 of Pr. 02-01–02-08 and Pr. 02-26–02-31 Multi-function Input Command) to select the multi-step speed command (the maximum is 15<sup>th</sup> step speed). Pr. 04-00 to Pr. 04-14 set the multi-step speed frequency as shown in the following diagram.

📖 The external terminal/digital keypad/communication controls the RUN and STOP commands with Pr.00-21.

📖 You can set each multi-step speed between 0.00–599.00 Hz during operation.

📖 Explanation for the timing diagram of the multi-step speed and external terminals

The related parameter settings are:

1. Pr. 04-00–04-14: sets the 1<sup>st</sup> to 15<sup>th</sup> multi-step speed (to set the frequency of each step speed)
2. Pr. 02-01–02-08 and Pr. 02-26–02-31: sets the multi-function input terminals (multi-step speed command 1–4)

📖 Related parameters:

- Pr. 01-22 JOG Frequency
- Pr. 02-01 Multi-function Input Command 1 (MI1)
- Pr. 02-02 Multi-function Input Command 2 (MI2)
- Pr. 02-03 Multi-function Input Command 3 (MI3)
- Pr. 02-04 Multi-function Input Command 4 (MI4)

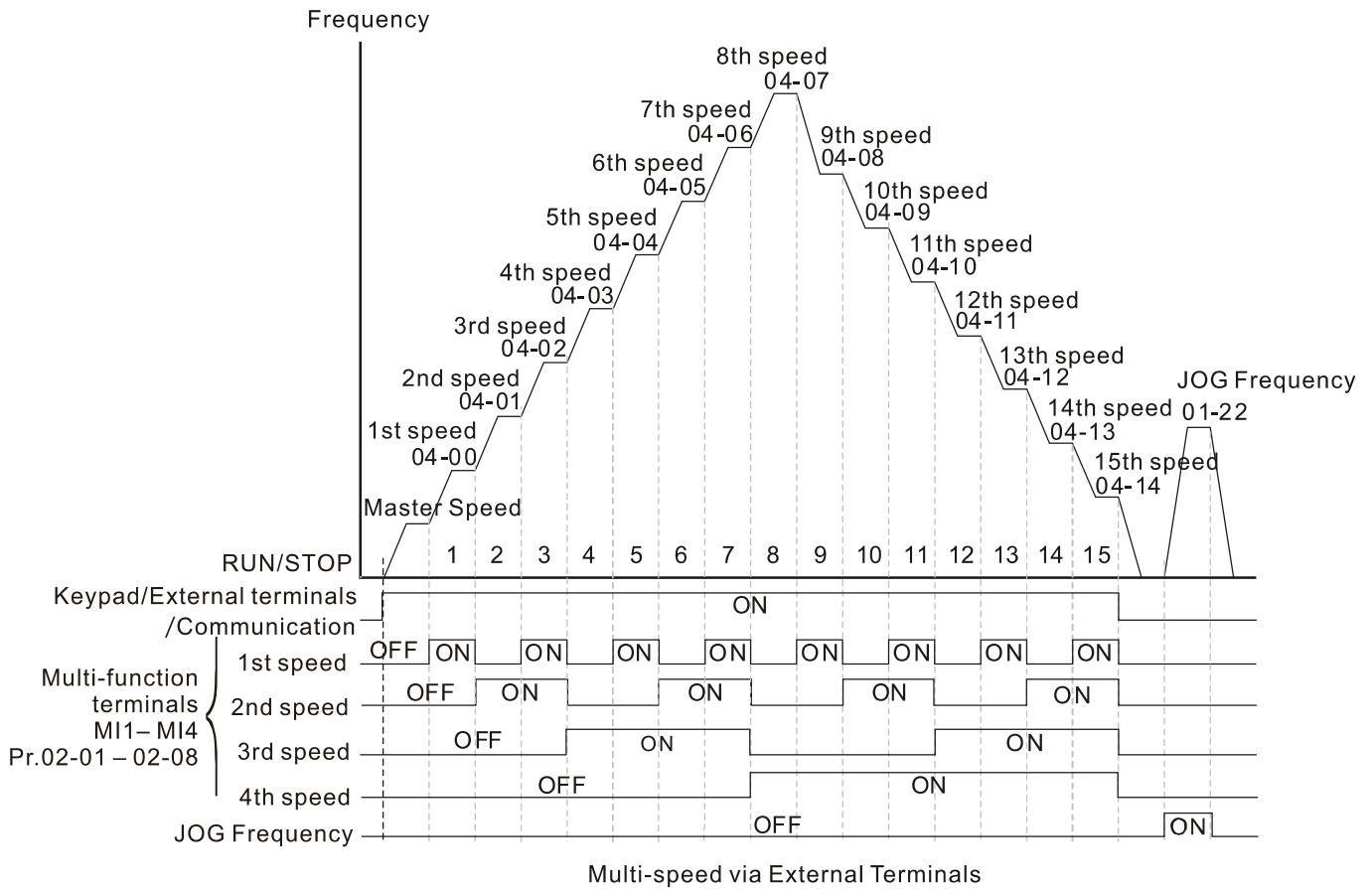

↗	<b>04-15</b>	Position Command 1 (Rotation)
↗	<b>04-17</b>	Position Command 2 (Rotation)
↗	<b>04-19</b>	Position Command 3 (Rotation)
↗	<b>04-21</b>	Position Command 4 (Rotation)
↗	<b>04-23</b>	Position Command 5 (Rotation)
↗	<b>04-25</b>	Position Command 6 (Rotation)
↗	<b>04-27</b>	Position Command 7 (Rotation)
↗	<b>04-29</b>	Position Command 8 (Rotation)
↗	<b>04-31</b>	Position Command 9 (Rotation)
↗	<b>04-33</b>	Position Command 10 (Rotation)
↗	<b>04-35</b>	Position Command 11 (Rotation)
↗	<b>04-37</b>	Position Command 12 (Rotation)
↗	<b>04-39</b>	Position Command 13 (Rotation)
↗	<b>04-41</b>	Position Command 14 (Rotation)
↗	<b>04-43</b>	Position Command 15 (Rotation)

Default: 0

Settings -30000–30000

To switch the target position for the external terminal, set the multi-function input command Pr.02-01 = 1, Pr.02-02 = 2, Pr.02-03 = 3, Pr.02-04 = 4 by selecting the P2P target position with the multi-step speed.

Setting: Target Position = Pr. 04-15 × (Pr. 10-01\*4) + Pr. 04-16

Multi-step Speed Status	Target Position of P2P			Maximum Speed of P2P	
				11-00 bit8=0	11-00 bit8=1
0000	0				
0001	Position 1	04-15	04-16	11-43	04-00
0010	Position 2	04-17	04-18		04-01
0011	Position 3	04-19	04-20		04-02
0100	Position 4	04-21	04-22	11-43	04-03
0101	Position 5	04-23	04-24		04-04
0110	Position 6	04-25	04-26		04-05
0111	Position 7	04-27	04-28		04-06
1000	Position 8	04-29	04-30	11-43	04-07
1001	Position 9	04-31	04-32		04-08
1010	Position 10	04-33	04-34		04-09
1011	Position 11	04-35	04-36		04-10
1100	Position 12	04-37	04-38		04-11
1101	Position 13	04-39	04-40		04-12
1110	Position 14	04-41	04-42		04-13
1111	Position 15	04-43	04-44	04-14	

- ↗ **04-16** Position Command 1 (Pulse)
- ↗ **04-18** Position Command 2 (Pulse)
- ↗ **04-20** Position Command 3 (Pulse)
- ↗ **04-22** Position Command 4 (Pulse)
- ↗ **04-24** Position Command 5 (Pulse)
- ↗ **04-26** Position Command 6 (Pulse)
- ↗ **04-28** Position Command 7 (Pulse)
- ↗ **04-30** Position Command 8 (Pulse)
- ↗ **04-32** Position Command 9 (Pulse)
- ↗ **04-34** Position Command 10 (Pulse)
- ↗ **04-36** Position Command 11 (Pulse)
- ↗ **04-38** Position Command 12 (Pulse)
- ↗ **04-40** Position Command 13 (Pulse)
- ↗ **04-42** Position Command 14 (Pulse)
- ↗ **04-44** Position Command 15 (Pulse)

Default: 0

Settings -32767–32767

- 📖 Refer to Pr. 02-01–02-08 (Multi-function Input Command) for the description on setting 34 (Switch between multi-step position and multi-step speed control), setting 36 (Enable multi-step position learning function) and setting 35 (Enable single-point position control).
- 📖 Multi-function input 35 (Enable single-point position control) switches between multi-step speed and multi-step position with multi-function input 34 (when enabled). You can select 16 positions.

Multi-step position corresponding	MI4	MI3	MI2	MI1	Multi-step speed corresponding
10-19	0	0	0	0	Positioning for Encoder Position
04-16 Position command 1 (pulse)	0	0	0	1	04-00 1 <sup>st</sup> step speed frequency
04-18 Position command 2 (pulse)	0	0	1	0	04-01 2 <sup>nd</sup> step speed frequency
04-20 Position command 3 (pulse)	0	0	1	1	04-02 3 <sup>rd</sup> step speed frequency

Multi-step position corresponding	MI4	MI3	MI2	MI1	Multi-step speed corresponding
04-22 Position command 4 (pulse)	0	1	0	0	04-03 4 <sup>th</sup> step speed frequency
04-24 Position command 5 (pulse)	0	1	0	1	04-04 5 <sup>th</sup> step speed frequency
04-26 Position command 6 (pulse)	0	1	1	0	04-05 6 <sup>th</sup> step speed frequency
04-28 Position command 7 (pulse)	0	1	1	1	04-06 7 <sup>th</sup> step speed frequency
04-30 Position command 8 (pulse)	1	0	0	0	04-07 8 <sup>th</sup> step speed frequency
04-32 Position command 9 (pulse)	1	0	0	1	04-08 9 <sup>th</sup> step speed frequency
04-34 Position command 10 (pulse)	1	0	1	0	04-09 10 <sup>th</sup> step speed frequency
04-36 Position command 11 (pulse)	1	0	1	1	04-10 11 <sup>th</sup> step speed frequency
04-38 Position command 12 (pulse)	1	1	0	0	04-11 12 <sup>th</sup> step speed frequency
04-40 Position command 13 (pulse)	1	1	0	1	04-12 13 <sup>th</sup> step speed frequency
04-42 Position command 14 (pulse)	1	1	1	0	04-13 14 <sup>th</sup> step speed frequency
04-44 Position command 15 (pulse)	1	1	1	1	04-14 15 <sup>th</sup> step speed frequency

↯	<b>04-50</b>	PLC Buffer 0
↯	<b>04-51</b>	PLC Buffer 1
↯	<b>04-52</b>	PLC Buffer 2
↯	<b>04-53</b>	PLC Buffer 3
↯	<b>04-54</b>	PLC Buffer 4
↯	<b>04-55</b>	PLC Buffer 5
↯	<b>04-56</b>	PLC Buffer 6
↯	<b>04-57</b>	PLC Buffer 7
↯	<b>04-58</b>	PLC Buffer 8
↯	<b>04-59</b>	PLC Buffer 9
↯	<b>04-60</b>	PLC Buffer 10
↯	<b>04-61</b>	PLC Buffer 11
↯	<b>04-62</b>	PLC Buffer 12
↯	<b>04-63</b>	PLC Buffer 13
↯	<b>04-64</b>	PLC Buffer 14
↯	<b>04-65</b>	PLC Buffer 15
↯	<b>04-66</b>	PLC Buffer 16
↯	<b>04-67</b>	PLC Buffer 17
↯	<b>04-68</b>	PLC Buffer 18
↯	<b>04-69</b>	PLC Buffer 19

Default: 0

Settings 0–65535

 You can combine the PLC buffer with the built-in PLC function for a variety of applications.



↗	04-70	PLC Application Parameter 0
↗	04-71	PLC Application Parameter 1
↗	04-72	PLC Application Parameter 2
↗	04-73	PLC Application Parameter 3
↗	04-74	PLC Application Parameter 4
↗	04-75	PLC Application Parameter 5
↗	04-76	PLC Application Parameter 6
↗	04-77	PLC Application Parameter 7
↗	04-78	PLC Application Parameter 8
↗	04-79	PLC Application Parameter 9
↗	04-80	PLC Application Parameter 10
↗	04-81	PLC Application Parameter 11
↗	04-82	PLC Application Parameter 12
↗	04-83	PLC Application Parameter 13
↗	04-84	PLC Application Parameter 14
	04-85	PLC Application Parameter 15
	04-86	PLC Application Parameter 16
	04-87	PLC Application Parameter 17
	04-88	PLC Application Parameter 18
	04-89	PLC Application Parameter 19
	04-90	PLC Application Parameter 20
	04-91	PLC Application Parameter 21
	04-92	PLC Application Parameter 22
	04-93	PLC Application Parameter 23
	04-94	PLC Application Parameter 24
	04-95	PLC Application Parameter 25
	04-96	PLC Application Parameter 26
	04-97	PLC Application Parameter 27
	04-98	PLC Application Parameter 28
	04-99	PLC Application Parameter 29

Default: 0

Settings 0–65535

 Pr. 04-70–Pr. 04-99 are user-defined parameters. You can combine these 30 PLC Application Parameters with the PLC programming for a variety of applications.

## 05 Motor Parameters

✎ This parameter can be set during operation.

### 05-00 Motor Parameter Auto-Tuning

Default: 0

- Settings
- 0: No function
  - 1: Simple rolling auto-tuning for induction motor (IM)
  - 2: Static auto-tuning for induction motor
  - 4: Dynamic test for PM magnetic pole (with the running in forward direction)
  - 5: Rolling auto-tuning for PM (IPM / SPM)
  - 6: Advanced rolling auto-tuning for IM flux curve
  - 12: FOC Sensorless inertia estimation
  - 13: Static auto-tuning for PM (IPM / SPM)

📖 Refer to Section 12-2 “Adjustment and Application” for more details of motor adjustment process.

### 05-01 Full-load Current for Induction Motor 1 (A)

Default: Depending on the model power

Settings Depending on the model power

📖 Sets this value according to the rated current of the motor as indicated on the motor nameplate.

📖 The default is 90% of the drive's rated current.

Example: The rated current for a 7.5 HP (5.5 kW) is 25 A. The default is 22.5 A.

The setting range is between 40%–120% of the rated current.

(25 \* 40% = 10 A and 25 \* 120% = 30 A)

### ✎ 05-02 Rated Power for Induction Motor 1 (kW)

Default: Depending on the model power

Settings 0.00–655.35 kW

📖 Sets the rated power for motor 1. The default is the drive's power value.

### ✎ 05-03 Rated Speed for Induction Motor 1 (rpm)

Default: Depending on the motor pole number

Settings 0–xxxx (Depending on the motor pole number)

📖 Sets the rated speed for the motor as indicated on the motor nameplate.



📖 Pr. 01-01 and Pr. 05-04 determine the maximum rotor speed for IM.

For example: Pr. 01-01=20Hz, Pr. 05-04=2, according to the equation  $120 \times 20 \text{ Hz} / 2 = 1200 \text{ rpm}$  and take integers. Due to the slip of the IM, the maximum setting value for Pr. 05-03 is 1199rpm (1200rpm – 1).

**05-04** Number of Poles for Induction Motor 1

Default: 4

Settings 2–64

-  Sets the number poles for the motor (must be an even number).
-  Set up Pr. 01-01 and Pr. 05-03 before setting up Pr. 05-04 to make sure the motor operates normally. Pr. 01-01 and Pr. 05-03 determine the maximum set up number poles for the IM.  
For example: Pr. 01-01 = 20 Hz and Pr. 05-03 = 39 rpm, according to the equation  $120 \times 20\text{Hz} / 39\text{rpm} = 61.5$  and take even number, the number of poles is 60. Therefore, Pr. 05-04 can be set to the maximum of 60 poles.

**05-05** No-load Current for Induction Motor 1 (A)

Default: Depending on the model power

Settings 0.0–Pr. 05-01 default

-  For model with 110kW and above, default setting is 20% of motor rated current.

**05-06** Stator Resistance (Rs) for Induction Motor 1

Default: Depending on the model power

Settings 0.000–65.535 Ω

**05-07** Rotor Resistance (Rr) for Induction Motor 1

Default: 0.000

Settings 0.000–65.535 Ω

**05-08** Magnetizing Inductance (Lm) for Induction Motor 1**05-09** Stator Inductance (Lx) for Induction Motor 1

Default: 0.0

Settings 0.0–6553.5 mH

**05-13** Full-load Current for Induction Motor 2 (A)

Default: Depending on the model power

Settings Depending on the model power

-  Set this value according to the rated current of the motor as indicated on the motor nameplate. The default 90% of the drive's rated current.  
Example: The rated current for a 7.5 HP (5.5 kW) motor is 25 A. The default is 22.5 A.  
The setting range is between 40 %–120 % of rated current.  
 $25 * 40 \% = 10 \text{ A}$  and  $25 * 120 \% = 30 \text{ A}$

↗ **05-14** Rated Power for Induction Motor 2 (kW)

Default: Depending on the model power

Settings 0.00–655.35 kW

---

📖 Set the rated power for motor 2. The default is the drive's power value.

↗ **05-15** Rated Speed for Induction Motor 2 (rpm)

Default: Depending on the motor pole number

Settings 0–xxxx (Depending on the motor pole number)

---

📖 Sets the rated speed for the motor as indicated on the motor nameplate.

📖 Pr. 01-01 and Pr. 05-04 determine the maximum rotor speed of IM.

For example: Pr. 01-01 = 20Hz, Pr. 05-04 = 2, according to the equation  $120 \times 20 \text{ Hz} / 2 = 1200$  rpm and take integers. Due to the slip of the IM, the maximum setting value for Pr. 05-15 is 1199 rpm ( $1200 \text{ rpm} - 1$ ).

**05-16** Number of poles for Induction Motor 2

Default: 4

Settings 2–64

---

📖 Sets the number of poles for the motor (must be an even number).

📖 Set up Pr. 01-35 and Pr. 05-15 before setting up Pr. 05-16 to make sure the motor operates normally. Pr. 01-35 and Pr. 05-15 determine the maximum set up number of poles.

For example: Pr. 01-35 = 20 Hz and Pr. 05-15 = 39 rpm, according to the equation  $120 \times 20\text{Hz} / 39 \text{ rpm} = 61.5$  and take even number, the number of poles is 60. Therefore, Pr. 05-16 can be set to the maximum of 60 poles.

**05-17** No-load Current for Induction Motor 2 (A)

Default: Depending on the model power

Settings 0.00–Pr. 05-13 default

---

📖 For model with 110kW and above, default setting is 20% of motor rated current.

**05-18** Stator Resistance (Rs) for Induction Motor 2

Default: Depending on the model power

Settings 0.000–65.535 Ω

---

**05-19** Rotor Resistance (Rr) for Induction Motor 2

Default: 0.000

Settings 0.000–65.535 Ω

---

**05-20** Magnetizing Inductance (Lm) for Induction Motor 2

**05-21** Stator Inductance (Lx) for Induction Motor 2

Default: 0.0

Settings 0.0–6553.5 mH

**05-22** Induction Motor 1/ 2 Selection

Default: 1

Settings 1: Motor 1  
2: Motor 2

📖 Sets the motor currently operated by the AC motor drive.

⚡ **05-23** Frequency for Y-connection / Δ-connection Switch for an Induction Motor

Default: 60.00

Settings 0.00–599.00 Hz

**05-24** Y-connection / Δ-connection Switch for Induction Motor

Default: 0

Settings 0: Disable  
1: Enable

⚡ **05-25** Delay Time for Y-connection / Δ-connection Switch for an Induction Motor

Default: 0.200

Settings 0.000–60.000 sec.

📖 You can apply Pr. 05-23–Pr. 05-25 in a wide range of motors, and the motor coil executes the Y-connection / Δ-connection switch as required. The wide range motors are related to the motor design. In general, the motor has higher torque with low speed Y-connection, and has higher speed with high speed Δ-connection).

📖 Pr. 05-24 enables and disables the switch of Y-connection / Δ-connection.

📖 When you set Pr. 05-24 as 1, the drive uses the Pr. 05-23 setting and current motor frequency, and switches the current motor to Y-connection or Δ-connection. You can switch the relevant motor parameter settings simultaneously.

📖 Pr. 05-25 sets the switch delay time of Y-connection / Δ-connection.

📖 When the output frequency reaches Y-connection / Δ-connection switch frequency, the drive delays according to Pr. 05-25 before activating the multi-function output terminals.

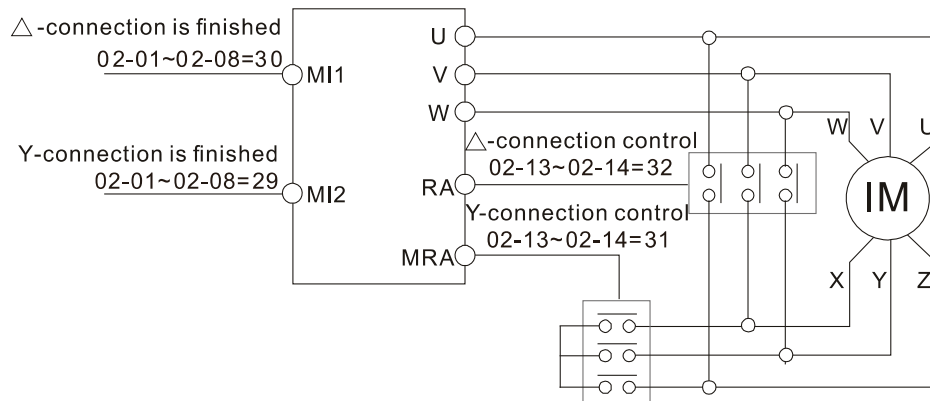

Y-△ connection switch: can be used for wide range motor

Y-connection for low speed: higher torque can be used for rigid tapping

△-connection for high speed: higher torque can be used for high-speed drilling

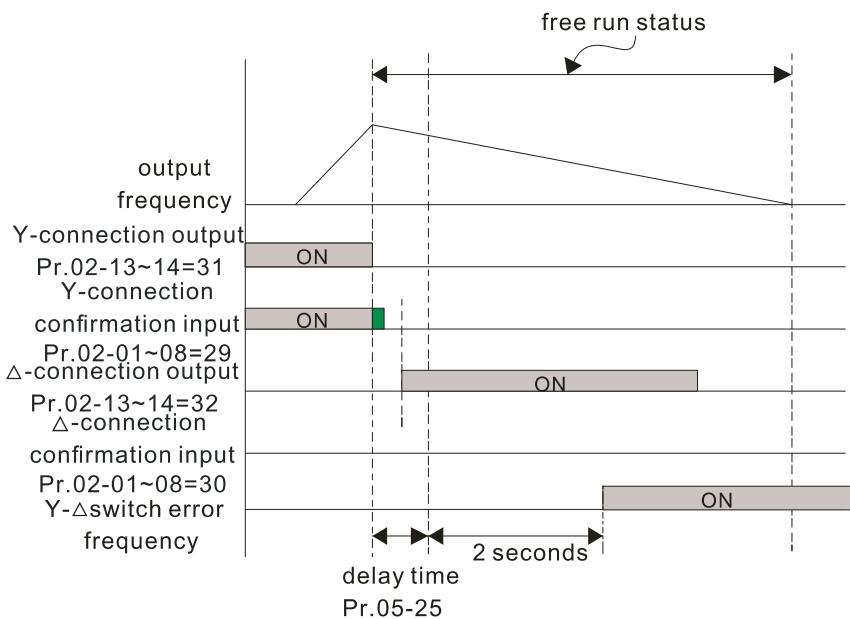
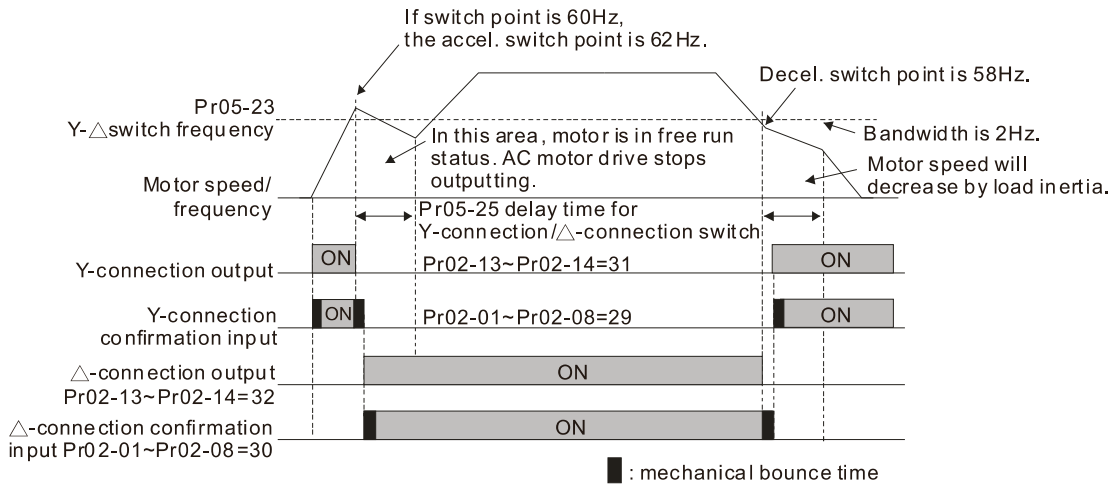

**05-28** Accumulated Watt-hour for a Motor (W-hour)

Default: 0.0

Settings Read only

**05-29** Accumulated Watt-hour for a Motor in Low Word (kW-hour)

Default: 0.0

Settings Read only

**05-30** Accumulated Watt-hour for a Motor in High Word (MW-hour)

Default: 0

Settings Read only

Pr.05-28–05-30 records the amount of power consumed by the motors. The accumulation begins when the drive is activated and the record is saved when the drive stops or turns OFF. The amount of consumed watts continues to accumulate when the drive is activated again. To clear the accumulation, set Pr. 00-02 as 5 to return the accumulation record to 0.

The accumulated total watts of the motor per hour = Pr. 05-30 x 1000000 + Pr. 05-29 x 1000 + Pr. 05-28 Wh

Example: When Pr. 05-30 = 76 MWh and Pr. 05-29 = 150 kWh, Pr. 05-28 = 400 Wh (or 0.4kWh), the accumulated total kilowatts of the motor per hour = 76 x 1000000 + 150 x 1000 + 40 = 76150400Wh = 76150.4kWh

<b>05-31</b>	Accumulated Motor Operation Time (Min)	Default: 0
	Settings 0–1439	

<b>05-32</b>	Accumulated Motor Operation Time (Day)	Default: 0
	Settings 0–65535	

 Use Pr. 05-31 and Pr. 05-32 to record the motor operation time. To clear the operation time, set Pr. 05-31 and Pr. 05-32 as 00. An operation time shorter than 60 seconds is not recorded.

<b>05-33</b>	Induction Motor (IM) or Permanent Magnet Synchronous Motor Selection	Default: 0
	Settings 0: IM (Induction Motor) 1: SPM (Surface permanent magnet motor) 2: IPM (Interior permanent magnet motor)	

<b>05-34</b>	Full-load current for a Permanent Magnet Motor	Default: Depending on the model power
	Settings Depending on the model power	

 Sets the full-load current for the motor according to motor's nameplate. The default is 90% of the drive's rated current.

 For example: The rated current of a 7.5 HP (5.5 kW) is 25 A. The default is 22.5A. The setting range is between 40%–120% of rated current.  
 $25 * 40 \% = 10 \text{ A}$  and  $25 * 120 \% = 30 \text{ A}$

 <b>05-35</b>	Rated Power for a Permanent Magnet Motor	Default: Depending on the model power
	Settings 0.00–655.35 kW	

 Sets the rated power for the permanent magnet synchronous motor. The default is the drive's power value.

 <b>05-36</b>	Rated speed for a Permanent Magnet Motor	Default: 2000
	Settings 0–65535 rpm	

<b>05-37</b>	Pole number for a Permanent Magnet Motor	Default: 10
	Settings 0–65535	

<b>05-38</b>	System Inertia for a Permanent Magnet Motor	Default: Depending on the motor power
	Settings 0.0–6553.5 kg-cm <sup>2</sup>	

 Default values are as below:

Rated Power [kW]	0.4	0.75	1.5	2.2	3.7	5.5	7.5	9.3	11
Rotor inertia [kg-cm <sup>2</sup> ]	1.2	3.0	6.6	15.8	25.7	49.6	82.0	121.6	177.0
Rated Power [kW]	14.1	18.2	27	33	40	46	54	54 and above	
Rotor inertia [kg-cm <sup>2</sup> ]	211.0	265.0	308.0	527.0	866.0	1082.0	1267.6	1515.0	

**05-39** Stator Resistance for a Permanent Magnet Motor

Default: 0.000

Settings 0.000–65.535 Ω

**05-40** Permanent Magnet Motor Ld

Default: 0.00

Settings 0.00–655.35 mH

**05-41** Permanent Magnet Motor Lq

Default: 0.00

Settings 0.00–655.35 mH

✎ **05-42** PG Offset Angle for a Permanent Magnet Motor

Default: 0

Settings 0.0–360.0°

📖 When you set Pr. 05-00 as 4, the drive detects the offset angle and writes it into Pr. 05-42.

✎ **05-43** Ke Parameter of a Permanent Magnet Motor

Default: 0

Settings 0–65535 V / krpm

📖 Permanent magnet motor parameter Ke ( $V_{\text{phase, rms}} / \text{krpm}$ )

📖 When Pr. 05-00 = 5, parameter Ke is calculated according to the motor's actual operation.

📖 When Pr. 05-00 = 13, parameter Ke is automatically calculated according to the motor power, current and rotor speed.



## 06 Protection Parameters

↗ This parameter can be set during operation.

### ↗ 06-00 Low Voltage Level

Default:

Settings	230V series:	Default:
	Frame A–D (including D0): 150.0–220.0 V <sub>DC</sub>	180.0
	Frame E and above: 190.0–220.0 V <sub>DC</sub>	200.0
	460V series:	
	Frame A–D (including D0): 300.0–440.0 V <sub>DC</sub>	360.0
	Frame E and above: 380.0–440.0 V <sub>DC</sub>	400.0
	575V series: 420.0–520.0 V <sub>DC</sub>	470.0
	690V series: 450.0–660.0 V <sub>DC</sub>	480.0

📖 Sets the Low Voltage (Lv) level. When the DC BUS voltage is lower than Pr. 06-00, the drive stops output and the motor free runs to a stop.

📖 If the Lv fault is triggered during operation, the drive stops output and the motor free runs to a stop. There are three Lv faults: LvA (Lv during acceleration), Lvd (Lv during deceleration), and Lvn (Lv in constant speed) that are triggered according to the status of acceleration or deceleration. You must press RESET to clear the Lv fault. The drive automatically restarts if you set to restart after momentary power loss (refer to Pr.07-06 Restart after Momentary Power Loss and Pr.07-07 Allowed Power Loss Duration for details).

📖 If the Lv fault is triggered when the drive is in STOP status, the drive displays LvS (Lv during stop), which is not recorded, and the drive restarts automatically when the input voltage is higher than Pr. 06-00 + Lv return level (as listed below).

Lv Return Level	230V	460V	575V	690V
Frame A–D	30V <sub>DC</sub>	60V <sub>DC</sub>	100V <sub>DC</sub>	100V <sub>DC</sub>
Frame E–H	40V <sub>DC</sub>	80V <sub>DC</sub>		120V <sub>DC</sub>

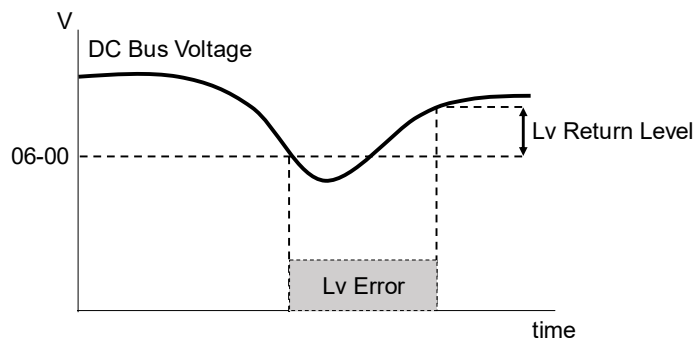

### ↗ 06-01 Over-voltage Stall Prevention

Default:

380.0/760.0/920.0/1087.0

Settings	230V series: 0.0–450.0 V <sub>DC</sub>
	460V series: 0.0–900.0V <sub>DC</sub>
	575V series: 0.0–920.0 V <sub>DC</sub>
	690V series: 0.0–1087.0 V <sub>DC</sub>
	0: Disabled

Setting Pr. 06-01 to 0.0 disables the over-voltage stall prevention function (connected with braking unit or braking resistor). Use this setting when braking units or resistors are connected to the drive.

Setting Pr.06-01 to a value > 0 enables the over-voltage stall prevention. This setting refers to the power supply system and loading. If the setting is too low, then over-voltage stall prevention is easily activated, which may increase the deceleration time.

Related parameters:

- Pr. 01-13, Pr. 01-15, Pr. 01-17, Pr. 01-19 Deceleration Time 1–4
- Pr. 02-13–Pr. 02-14 Multiple-function Output (Relay 1 and 2)
- Pr. 02-16–Pr. 02-17 Multiple-function output (MO 1 and 2)
- Pr. 06-02 Selection for Over-voltage Stall Prevention.

## 06-02 Selection for Over-voltage Stall Prevention

Default: 0

Settings 0: Traditional over-voltage stall prevention

1: Smart over-voltage stall prevention

Use this function when you are unsure about the load inertia. When stopping under normal load, the over-voltage does not occur during deceleration and meet the deceleration time setting. Sometimes it may not stop due to over-voltage during decelerating to STOP when the load regenerative inertia increases. In this case, the AC motor drive extends the deceleration time automatically until the drive stops.

When you set Pr.06-02 to 0, during deceleration the motor exceeds the synchronous speed due to load inertia. In this case, the motor becomes an electrical generator. The DC BUS voltage may exceed its maximum allowable value due to motor regeneration in some situations, such as loading inertia being too high or deceleration time being set too short. When you enable traditional over-voltage stall prevention and the DC BUS voltage detected is too high, the drive stops decelerating (output frequency remains unchanged) until the DC BUS voltage drops below the setting value.

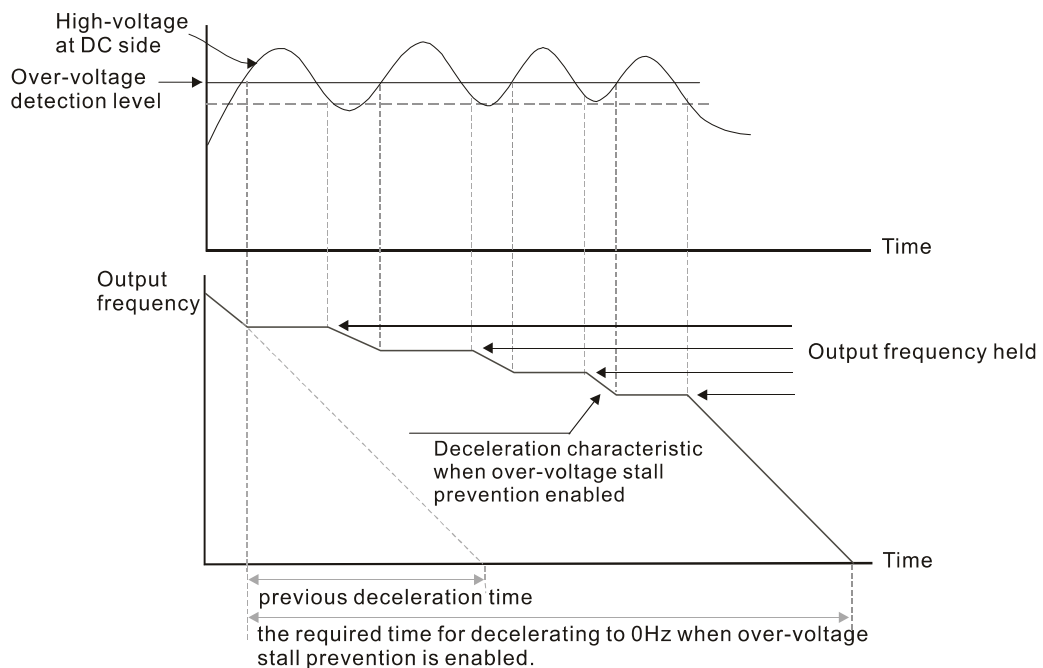

When you set Pr. 06-02 to 1, to use smart over-voltage stall prevention during deceleration, the drive maintains the DC BUS voltage when decelerating and prevents the drive from ov.

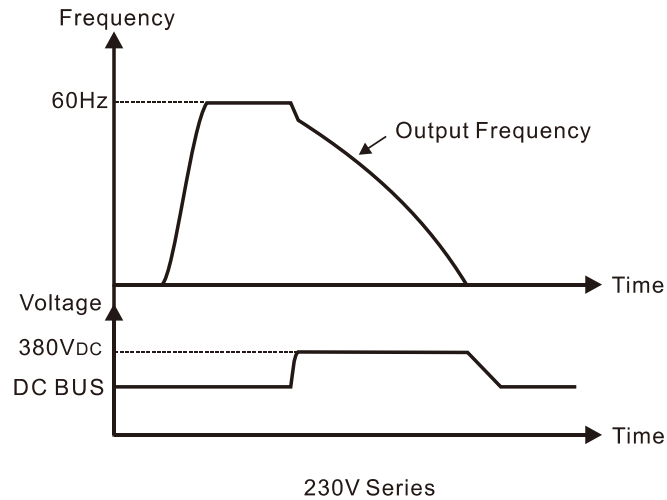

When you enable the over-voltage stall prevention, the drive’s deceleration time is longer than the setting.

If you encounter any problem with deceleration time, refer to the following guides for troubleshooting.

1. Increase the deceleration time to a suitable value.
2. Install a brake resistor (refer to Section 7-1 All Brake Resistors and Brake Units Used in AC motor Drives for details) to dissipate the electrical energy that is regenerated from the motor.

Related parameters:

- Pr. 01-13, Pr. 01-15, Pr. 01-17, Pr. 01-19 Deceleration Time 1–4
- Pr. 02-13–Pr. 02-14 Multiple-function Output (Relay 1 and 2)
- Pr. 02-16–Pr. 02-17 Multiple-function Output (MO1 and 2)
- Pr. 06-01 Over-voltage Stall Prevention.

**06-03** Over-current Stall Prevention during Acceleration

Settings	230V/460V series	
	Normal duty: 0–160% (100%: drive’s rated current)	Default: 120
	Heavy duty: 0–180% (100%: drive’s rated current)	Default: 120
	575V/690V series	
	Light duty: 0–125% (100%: drive’s rated current)	Default: 120
	Normal duty: 0–150% (100%: drive’s rated current)	Default: 120
	Heavy duty: 0–180% (100%: drive’s rated current)	Default: 150

This parameter only works in VF, VFPG, and SVC control mode.

If the motor load is too large or the drive’s acceleration time is too short, the output current of the drive may be too high during acceleration, and it may cause motor damage or trigger protection functions (oL or oc). Use this parameter to prevent these situations.

During acceleration, the output current of the drive may increase abruptly and exceed the value of Pr. 06-03. In this case, the drive stops accelerating and keeps the output frequency constant, and then continues to accelerate until the output current decreases.

- 📖 When you enable the over-current stall prevention, the drive's acceleration time is longer than the setting.
- 📖 When the over-current stall prevention occurs because the motor capacity is too small or operates in the default, decrease the Pr.06-03 setting value.
- 📖 When you encounter any problem with the acceleration time, refer to the following guides for troubleshooting.
  1. Increase the acceleration time to a suitable value.
  2. Set Pr. 01-44 Auto Acceleration / Deceleration Setting to 1, 3 or 4 (auto-acceleration).

📖 Related parameters:

- Pr. 01-12, Pr. 01-14, Pr. 01-16, Pr. 01-18 Acceleration Time 1–4
- Pr. 01-44 Auto Acceleration / Deceleration Setting
- Pr. 02-13–02-14 Multi-function Output 1 (RY1 and RY2)
- Pr. 02-16–02-17 Multi-function Output (MO1 and 2)

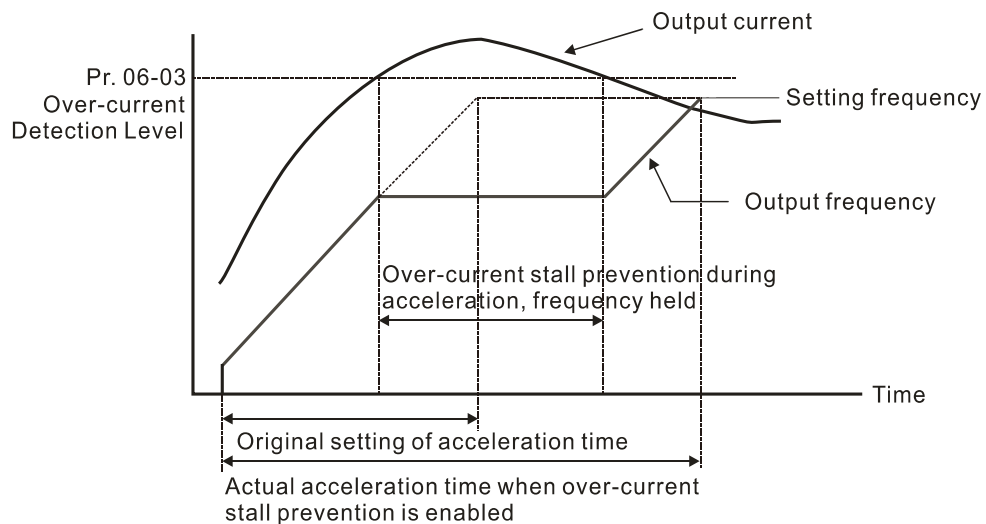

## 🔪 06-04 Over-current Stall Prevention during Operation

Settings 230V/460V series

Normal duty: 0–160% (100%: drive's rated current) Default: 120

Heavy duty: 0–180% (100%: drive's rated current) Default: 120

575V/690V series

Light duty: 0–125% (100%: drive's rated current) Default: 120

Normal duty: 0–150% (100%: drive's rated current) Default: 120

Heavy duty: 0–180% (100%: drive's rated current) Default: 150

- 📖 This parameter only works in VF, VFPG, and SVC control modes.
- 📖 This is a protection for the drive to decrease output frequency automatically when the motor over-loads abruptly during constant motor operation.
- 📖 If the output current exceeds the setting value for Pr. 06-04 when the drive is operating, the drive decreases output frequency (according to Pr. 06-05) to prevent the motor from stalling. If the output current is lower than the setting value for Pr. 06-04, the drive accelerates (according to Pr. 06-05) again to the setting frequency.

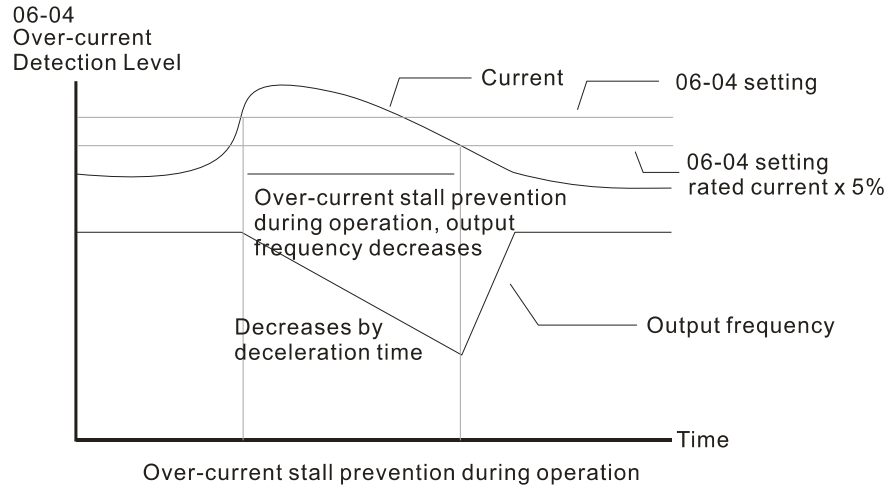

**06-05** Acceleration / Deceleration Time Selection of Stall Prevention at Constant Speed Default: 0

- Settings
- 0: By current acceleration / deceleration time
  - 1: By the 1<sup>st</sup> acceleration / deceleration time
  - 2: By the 2<sup>nd</sup> acceleration / deceleration time
  - 3: By the 3<sup>rd</sup> acceleration / deceleration time
  - 4: By the 4<sup>th</sup> acceleration / deceleration time
  - 5: By automatic acceleration / deceleration

📖 Sets the acceleration / deceleration time selection when stall prevention occurs at constant speed.

**06-06** Over-torque Detection Selection (OT1) Default: 0

- Settings
- 0: No function
  - 1: Continue operation after over-torque detection during constant speed operation
  - 2: Stop after over-torque detection during constant speed operation
  - 3: Continue operation after over-torque detection during RUN
  - 4: Stop after over-torque detection during RUN

**06-09** Over-torque Detection Selection (OT2) Default: 0

- Settings
- 0: No function
  - 1: Continue operation after over-torque detection during constant speed operation
  - 2: Stop after over-torque detection during constant speed operation
  - 3: Continue operation after over-torque detection during RUN
  - 4: Stop after over-torque detection during RUN

📖 When you set Pr. 06-06 and Pr. 06-09 to 1 or 3, a warning message displays, but there is no error record.

📖 When you set Pr. 06-06 and Pr. 06-09 to 2 or 4, a warning message displays and there is an error record.

- ↗ **06-07** Over-torque Detection Level (OT1) Default: 120  
 Settings 10–250% (100% corresponds to the rated current of the drive)
- ↗ **06-08** Over-torque Detection Level (OT1) Default: 0.1  
 Settings 0.0–60.0 sec.
- ↗ **06-10** Over-torque Detection Level (OT2) Default: 120  
 Settings 10–250% (100% corresponds to the rated current of the drive)
- ↗ **06-11** Over-torque Detection Time (OT2) Default: 0.1  
 Settings 0.0–60.0 sec.

📖 When the output current exceeds the over-torque detection level (Pr. 06-07 or Pr. 06-10) and exceeds the over-torque detection time (Pr. 06-08 or Pr. 06-11), the over-torque detection follows the setting of Pr. 06-06 and Pr. 06-09.

📖 When you set Pr. 06-06 or Pr. 06-09 to 1 or 3, an ot1 / ot2 warning displays while the drive keeps running. The warning remains on until the output current is smaller than 5% of the over-torque detection level.

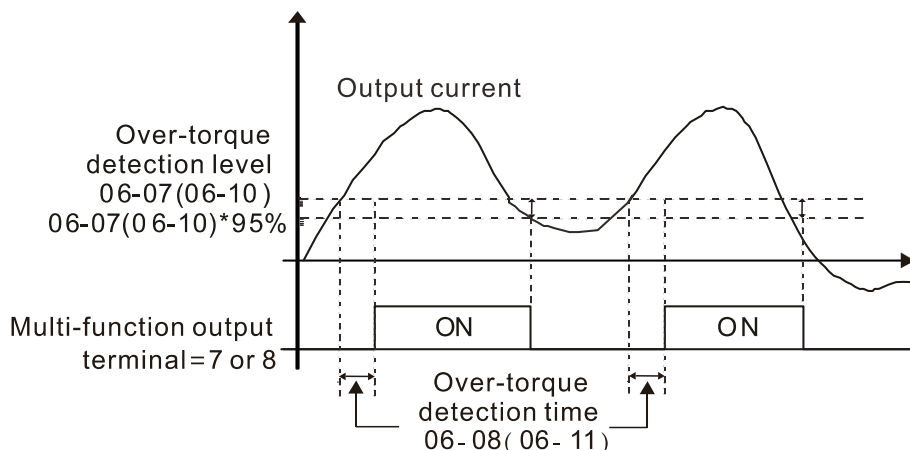

📖 When you set Pr. 06-06 or Pr. 06-09 to 2 or 4, an ot1 / ot2 warning displays and the drive stops running after over-torque detection. The drive keeps running after you manually reset it.

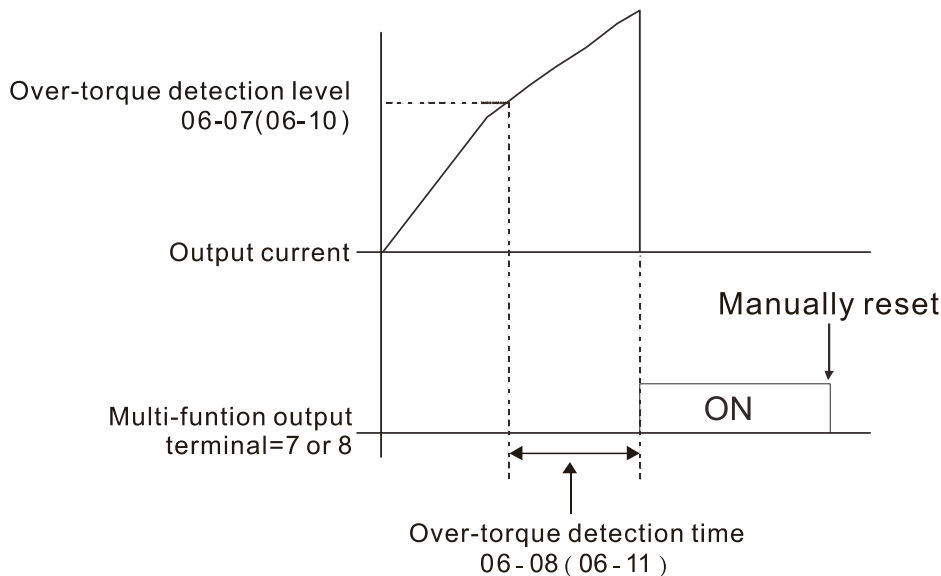

↗ **06-12** Current Limit

Default: 170

Settings 0–250% (100% corresponds to the rated current of the drive)

- 📖 Sets the maximum output current of the drive. Use Pr.11-17–Pr.11-20 to set the drive’s output current limit.
- 📖 When setting the control mode as VF, SVC or VFPG, if the output frequency of the drive reaches this current limit, the output frequency decreases automatically. It works like the current stall prevention.

↗ **06-13** Electronic Thermal Relay Selection (Motor 1)

↗ **06-27** Electronic Thermal Relay Selection (Motor 2)

Default: 2

Settings 0: Inverter motor (with external forced cooling)  
 1: Standard motor (motor with fan on the shaft)  
 2: Disable

- 📖 Prevents self-cooled motor from overheating under low speed. Use an electronic thermal relay to limit the drive’s output power.
- 📖 Setting the parameter to 0 is suitable for an inverter motor (motor fan using an independent power supply). For this kind of motor, there is no significant correlation between cooling capacity and motor speed. Therefore, the action of electronic thermal relays remains stable in low speed to ensure the load capability of the motor in low speed.
- 📖 Setting the parameter to 1 is suitable for standard motor (motor fan is fixed on the rotor shaft). For this kind of motor, the cooling capacity is lower in low speed; therefore, the action of an electronic thermal relay reduces the action time to ensure the life of motor.
- 📖 When the power is cycled frequently, if the power is switched OFF, the electronic thermal relay protection is reset; therefore even setting the parameter to 0 or 1 may not protect the motor well. If there are several motors connected to one drive, install an electronic thermal relay in each motor.

↗ **06-14** Electronic Thermal Relay Action Time 1 (Motor 1)

↗ **06-28** Electronic Thermal Relay Action Time 2 (Motor 2)

Default: 60.0

Settings 30.0–600.0 sec.

- 📖 Set the parameter to 150% of motor rated current and use with the setting of Pr.06-14 and Pr.06-28 to prevent motor damage due to overheating. When it reaches the setting, the drive displays “EoL1 / EoL2”, and the motor free runs to stop.
- 📖 Use this parameter to set the action time of the electronic thermal relay. It works based on the I<sup>2</sup>t characteristic curve of electronic thermal relay, the output frequency and current of the drive, and the operation time to prevent the motor from overheating.

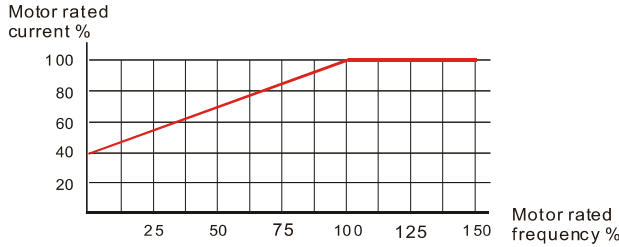

Motor cooling curve with shaft-fixed fan

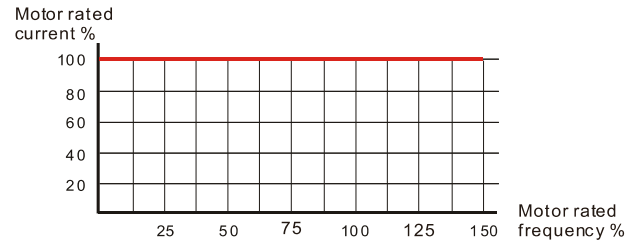

Motor cooling curve with independent fan

The action of electronic thermal relay depends on the setting for Pr. 06-13 and Pr. 06-27.

1. Pr. 06-13 or Pr. 06-27 set to 0 (using inverter motor):

When the output current of motor drive is higher than 150% of motor rated current (refer to the motor cooling curve with independent fan), motor drive starts to count the time. The electronic thermal relay acts when the accumulated time exceeds Pr. 06-14 or Pr. 06-28.

2. Pr. 06-13 or Pr. 06-27 is set to 1 (using standard motor):

When the output current of the drive is higher than 150% of the motor rated current (refer to the motor cooling curve with shaft-fixed fan), the drive starts to count the time. The electronic thermal relay acts when the accumulated time exceeds Pr. 06-14 or Pr. 06-28.

3. If the motor's rated current (Pr. 05-01) is not set, then set 90% of the drive's rated current (Pr. 00-01) as the default value of this parameter.

The actual electronic thermal relay action time adjusts according to the drive output current (shown as the motor loading rate %). The action time is short when the current is high, and the action time is long when the current is low. Refer to the following chart: (The motor cooling curve with shaft-fixed fan and motor cooling curve with independent fan F = 50 Hz are the same one.)

Operation time  
(sec.)

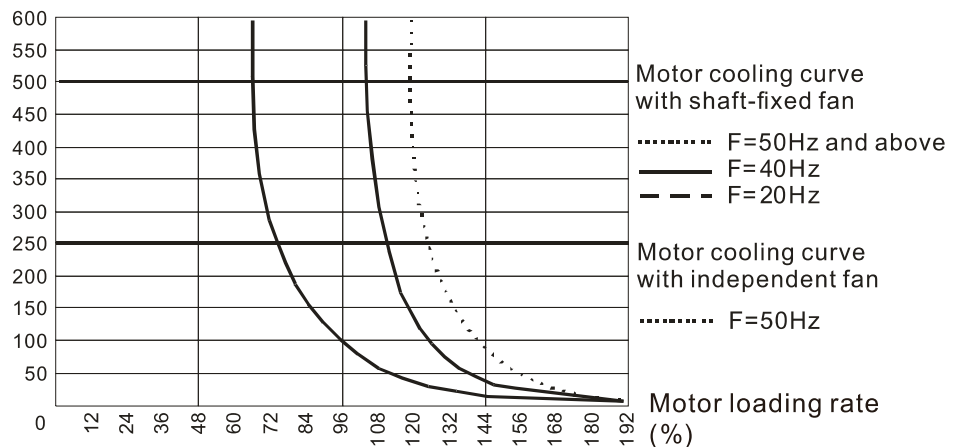

**06-15** Temperature Level Over-heat (oH) Warning

Default: 105.0

Settings 0.0–110.0°C

If Pr. 06-15 is set to 110°C, when the temperature reaches 110°C, the drive stops with an IGBT over-heat fault.

For Frame C and above, when IGBT temperature is above Pr. 06-15 minus 15°C, the cooling fan enhances performance to 100%; however, when IGBT temperature is below 35°C of Pr. 06-15 and the temperature of CAP is below 10°C of capacitor oH warning level (Pr. 06-51), the cooling fan resets. The temperature 35°C is the criterion if Pr. 06-15 is set below 35°C.



↗ **06-16** Stall Prevention Limit Level (Weak Magnetic Area Current Stall Prevention Level)

Default: 100

Settings 0–100% (Refer to Pr. 06-03, Pr. 06-04)

- 📖 Sets the over-current stall prevention level when operation frequency is larger than Pr.01-01. This parameter only works during acceleration.
- 📖 Example: Pr. 06-03 = 150%, Pr. 06-04 = 100% and Pr. 06-16 = 80%, when the operation frequency is larger than Pr. 01-01, the over-current stall prevention Level during acceleration is:  
Pr. 06-03 × Pr. 06-16 = 150 × 80% = 120%.
- 📖 Pr. 06-16 is invalid when the over-current stall prevention activates according to Pr. 06-04 at constant speed.

**06-17** Fault Record 1

**06-18** Fault Record 2

**06-19** Fault Record 3

**06-20** Fault Record 4

**06-21** Fault Record 5

**06-22** Fault Record 6

Settings

0: No fault record

1: Over-current during acceleration (ocA)

2: Over-current during deceleration (ocd)

3: Over-current during constant speed(ocn)

4: Ground fault (GFF)

5: IGBT short-circuit (occ)

6: Over-current at stop (ocS)

7: Over-voltage during acceleration (ovA)

8: Over-voltage during deceleration (ovd)

9: Over-voltage during constant speed (ovn)

10: Over-voltage at stop (ovS)

11: Low-voltage during acceleration (LvA)

12: Low-voltage during deceleration (Lvd)

13: Low-voltage during constant speed (Lvn)

14: Low-voltage at stop (LvS)

15: Phase loss protection (OrP)

16: IGBT over-heat (oH1)

17: Capacitance over-heat (oH2)

18: tH1o (TH1 open: IGBT over-heat protection error)

19: tH2o (TH2 open: capacitance over-heat protection error)

21: Drive over-load (oL)



22: Electronics thermal relay protection 1 (EoL1)









23: Electronics thermal relay protection 2 (EoL2)

24: Motor PTC overheat (oH3) (PTC / PT100)

- 26: Over-torque 1 (ot1)
- 27: Over-torque 2 (ot2)
- 28: Low current (uC)
- 29: Home limit error (LMIT)
- 30: Memory write-in error (cF1)
- 31: Memory read-out error (cF2)
- 33: U-phase current detection error (cd1)
- 34: V-phase current detection error (cd2)
- 35: W-phase current detection error (cd3)
- 36: Clamp current detection error (Hd0)
- 37: Over-current detection error (Hd1)
- 38: Over-voltage detection error (Hd2)
- 39: IGBT short-circuit detection error (Hd3)
- 40: Auto-tuning error (AUE)
- 41: PID feedback loss (AFE)
- 42: PG feedback error (PGF1)
- 43: PG feedback loss (PGF2)
- 44: PG feedback stall (PGF3)
- 45: PG slip error (PGF4)
- 48: Analog current input loss (ACE)
- 49: External fault input (EF)
- 50: Emergency stop (EF1)
- 51: External Base Block (bb)
- 52: Password error (PcodE)
- 54: Communication error (CE1)
- 55: Communication error (CE2)
- 56: Communication error (CE3)
- 57: Communication error (CE4)
- 58: Communication Time-out (CE10)
- 60: Brake transistor error (bF)
- 61: Y-connection /  $\Delta$ -connection switch error (ydc)
- 62: Deceleration Energy Backup error (dEb)
- 63: Slip error (oSL)
- 64: Electromagnet switch error (ryF)
- 65: PG Card Error (PGF5)
- 68: Sensorless estimated speed have wrong direction
- 69: Sensorless estimated speed is over speed
- 70: Sensorless estimated speed deviated
- 71: Watchdog
- 72: Channel 1 (STO1–SCM1) safety loop error (STL1)
- 73: External safety gate (S1)
- 75: External brake error

- 76: Safe Torque Off (STO)
- 77: Channel 2 (STO2–SCM2) safety loop error (STL2)
- 78: Internal loop error (STL3)
- 82: U phase output phase loss (OPHL)
- 83: V phase output phase loss (OPHL)
- 84: W phase output phase loss (OPHL)
- 85: PG-02U ABZ hardware disconnection
- 86: PG-02U UVW hardware disconnection
- 87: oL3 Low frequency overload protection
- 89: RoPd initial rotor position detection error
- 90: Inner PLC function is forced to stop
- 93: CPU error
- 101: CANopen software disconnect 1 (CGdE)
- 102: CANopen software disconnect 2 (CHbE)
- 104: CANopen hardware disconnect (CbFE)
- 105: CANopen index setting error (CIdE)
- 106: CANopen slave station number setting error (CAdE)
- 107: CANopen index setting exceed limit (CFrE)
- 111: Internal communication overtime error (ictE)
- 112: PM sensorless shaft Lock error
- 142: Auto-tuning error 1 (no feedback current error) (AUE1)
- 143: Auto-tuning error 2 (motor phase loss error) (AUE2)
- 144: Auto-tuning error 3 (no-load current  $I_0$  measuring error) (AUE3)
- 148: Auto-tuning error (leakage inductance  $L_{\sigma}$  measuring error) (AUE4)

-  When the fault occurs and forces stopping, the fault is recorded in this parameter.
-  During stop with low voltage Lv (LvS warning), there is no error record. During operation with mid-low voltage Lv (LvA, Lvd, Lvn error), there is a record.
-  When dEb function is valid and enabled, the drive executes dEb and records fault code 62 to Pr. 06-17–Pr. 06-22 simultaneously.

		Fault Output Option 1
		Fault Output Option 2
		Fault Output Option 3
		Fault Output Option 4

Default: 0

Settings 0–65535 sec. (refer to bit table for fault code)

-  Use these parameters with multi-function output terminal (set to 35–38) for the specific requirement. When the fault occurs, the corresponding terminals activate. Convert the binary value to decimal value before you enter the value for Pr. 06-23–Pr. 06-26.

Fault Code	bit0	bit1	bit2	bit3	bit4	bit5	bit6
	current	Volt.	OL	SYS	FBK	EXI	CE
0: No fault record							
1: Over-current during acceleration (ocA)	•						
2: Over-current during deceleration (ocd)	•						
3: Over-current during constant speed(ocn)	•						
4: Ground fault (GFF)	•						
5: IGBT short-circuit (occ)	•						
6: Over-current at stop (ocS)	•						
7: Over-voltage during acceleration (ovA)		•					
8: Over-voltage during deceleration (ovd)		•					
9: Over-voltage during constant speed (ovn)		•					
10: Over-voltage at stop (ovS)		•					
11: Low-voltage during acceleration (LvA)		•					
12: Low-voltage during deceleration (Lvd)		•					
13: Low-voltage during constant speed (Lvn)		•					
14: Low-voltage at stop (LvS )		•					
15: Phase loss protection (OrP)		•					
16: IGBT over-heat (oH1)			•				
17: Capacitance over-heat (oH2)			•				
18: tH1o (TH1 open)			•				
19: tH2o (TH2 open)			•				
21: Drive over-load (oL)			•				
22: Electronics thermal relay protection 1 (EoL1)			•				
23: Electronics thermal relay 2 protection (EoL2)			•				
24: Motor PTC overheat (oH3) (PTC / PT100)			•				
26: Over-torque 1 (ot1)			•				
27: Over-torque 2 (ot2)			•				
28: Low current (uC)	•						
29: Home limit error (LMIT)						•	
30: Memory write-in error (cF1)				•			
31: Memory read-out error (cF2)				•			
33: U-phase current detection error (cd1)				•			
34: V-phase current detection error (cd2)				•			
35: W-phase current detection error (cd3)				•			
36: Clamp current detection error (Hd0)				•			
37: Over-current detection error (Hd1)				•			
38: Over-voltage detection error (Hd2)				•			
39: IGBT short-circuit detection error (Hd3)				•			
40: Auto-tuning error (AUE)				•			

Fault Code	bit0	bit1	bit2	bit3	bit4	bit5	bit6
	current	Volt.	OL	SYS	FBK	EXI	CE
41: PID feedback loss (AFE)					•		
42: PG feedback error (PGF1)					•		
43: PG feedback loss (PGF2)					•		
44: PG feedback stall (PGF3)					•		
45: PG slip error (PGF4)					•		
48: Analog current input loss (ACE)					•		
49: External fault input (EF)						•	
50: Emergency stop (EF1)						•	
51: External Base Block (bb)						•	
52: Password error (Pcod)				•			
54: Communication error (CE1)							•
55: Communication error (CE2)							•
56: Communication error (CE3)							•
57: Communication error (CE4)							•
58: Communication time-out (CE10)							•
60: Brake transistor error (bF)						•	
61: Y-connection/ $\Delta$ -connection switch error (ydc)						•	
62: Deceleration Energy Backup error (dEb)		•					
63: Slip error (oSL)						•	
64: Electromagnet switch error (ryF)						•	
65: PG Card Error (PGF5)						•	
68: Sensorless estimated speed have wrong direction					•		
69: Sensorless estimated speed is over speed					•		
70: Sensorless estimated speed deviated					•		
72: Channel 1 (STO1–SCM1) safety loop error (STL1)				•			
73: External safety gate S1				•			
75: external brake error						•	
76: Safe Torque Off (STO)				•			
77: Channel 2 (STO2–SCM2) safety loop error (STL2)				•			
78: Internal loop error (STL3)				•			
82: U phase output phase loss (OPHL)	•						
83: V phase output phase loss (OPHL)	•						
84: W phase output phase loss (OPHL)	•						
85: PG-02U ABZ hardware disconnection					•		
86: PG-02U UVW hardware disconnection					•		

Fault Code	bit0	bit1	bit2	bit3	bit4	bit5	bit6
	current	Volt.	OL	SYS	FBK	EXI	CE
89: Initial rotor position detection error					•		
90: Inner PLC function is forced to stop				•			
101: CANopen software disconnect 1 (CGdE)							•
102: CANopen software disconnect 2 (CHbE)							•
104: CANopen hardware disconnect (CbFE)							•
105: CANopen index setting error (CIdE)							•
106: CANopen slave station number setting error (CAdE)							•
107: CANopen index setting exceed limit (CFrE)							•
111: Internal communication overtime error (ictE)							•
112: PM sensorless shaft Lock error					•		

### 06-29 PTC Detection Selection / PT100 Motion

Default: 0

- Settings
- 0: Warn and continue operation
  - 1: Warn and ramp to stop
  - 2: Warn and coast to stop
  - 3: No warning

 Sets the operation mode of a drive after you set Pr. 06-29 to define PTC / PT100 / KTY84 detection.

### 06-30 PTC Level / KTY84 Level

Default: 50.0

Settings 0.0–100.0 %

 When Pr. 06-86 = 0, the setting range is 0.0–100.0, with unit %, and the default is 50.0%.

When Pr. 06-86 = 1, the setting range is 0.0–150.0, with unit °C, and the default is 125.0°C

 Sets AVI/ACI/AUI analog input function Pr. 03-00–03-02 to 6 [Positive Temperature Coefficient (P.T.C.) thermistor input value].

 The AUI terminal does not support KTY84-130.

 Use this to set the PTC / KTY84 level, the corresponding value for 100% is the analog input maximum value.

 When Pr. 06-86 is set as KTY84, Pr. 06-30 setting range and the unit changes automatically.

### 06-31 Frequency Command for Malfunction

Default: Read only

Settings 0.00–599.00 Hz

 When a malfunction occurs, check the current frequency command. If it happens again, it overwrites the previous record.

**06-32** Output Frequency at Malfunction

Default: Read only

Settings 0.00–599.00 Hz

 When a malfunction occurs, check the current output frequency. If it happens again, it overwrites the previous record.

**06-33** Output Voltage at Malfunction

Default: Read only

Settings 0.0–6553.5 V

 When a malfunction occurs, check the current output voltage. If it happens again, it overwrites the previous record.

**06-34** DC Voltage at Malfunction

Default: Read only

Settings 0.0–6553.5 V

 When a malfunction occurs, check the current DC voltage. If it happens again, it overwrites the previous record.

**06-35** Output Current at Malfunction

Default: Read only

Settings 0.0–6553.5 Amp

 When a malfunction occurs, check the current output current. If it happens again, it overwrites the previous record.

**06-36** IGBT Temperature at Malfunction

Default: Read only

Settings -3276.7–3276.7°C

 When a malfunction occurs, check the current IGBT temperature. If it happens again, it overwrites the previous record.

**06-37** Capacitance Temperature at Malfunction

Default: Read only

Settings -3276.7–3276.7°C

 When a malfunction occurs, check the current capacitance temperature. If it happens again, it overwrites the previous record.

**06-38** Motor Speed in rpm at Malfunction

Default: Read only

Settings -32767–32767 rpm

 When a malfunction occurs, check the current motor speed in rpm. If it happens again, it overwrites the previous record.

**06-39** Torque Command at Malfunction

Default: Read only

Settings -32767–32767%

When a malfunction occurs, check the current torque command. If it happens again, it overwrites the previous record.

**06-40** Status of the Multi-function Input Terminal at Malfunction

Default: Read only

Settings 0000h–FFFFh

**06-41** Status of the Multi-function Output Terminal at Malfunction

Default: Read only

Settings 0000h–FFFFh

When a malfunction occurs, check the status of multi-function input / output terminals. If it happens again, it overwrites the previous record.

**06-42** Drive Status at Malfunction

Default: Read only

Settings 0000h–FFFFh

When a malfunction occurs, check the current drive status (communication address 2101H). If it happens again, it overwrites the previous record.

↗ **06-44** STO Latch Selection

Default: 0

Settings 0: STO latch  
1: STO no latch

Pr. 06-44 = 0: STO Alarm Latch. After you clear the cause of the STO Alarm, use a Reset command to clear the STO Alarm.

Pr. 06-44 = 1: STO Alarm no Latch. After you clear the cause of the STO Alarm, the STO Alarm clears automatically.

All of STL1–STL3 errors are “Alarm Latch” mode (in STL1–STL3 mode, the Pr. 06-44 function is no effective).

↗ **06-45** Treatment to Output Phase Loss Protection (OPHL)

Default: 3

Settings 0: Warn and continue operation  
1: Warn and ramp to stop  
2: Warn and coast to stop  
3: No warning

The OPHL protect function is active when the setting is not 3.

↗ **06-46** Detection Time of Output Phase Loss

Default: 3.000

Settings 0.000–65.535 sec.



↗ **06-47** Current Detection Level for Output Phase Loss Default: 1.00  
 Settings 0.00–100.00%

↗ **06-48** DC Brake Time of Output Phase Loss Default: 0.000  
 Settings 0.000–65.535 sec.

📖 Setting Pr. 06-48 to 0 disables the OPHL detection function.

📖 Status 1: The drive is in operation

When any phase is less than the Pr. 06-47 setting, and exceeds the Pr. 06-46 setting time, the drive executes according to the Pr. 06-45 setting.

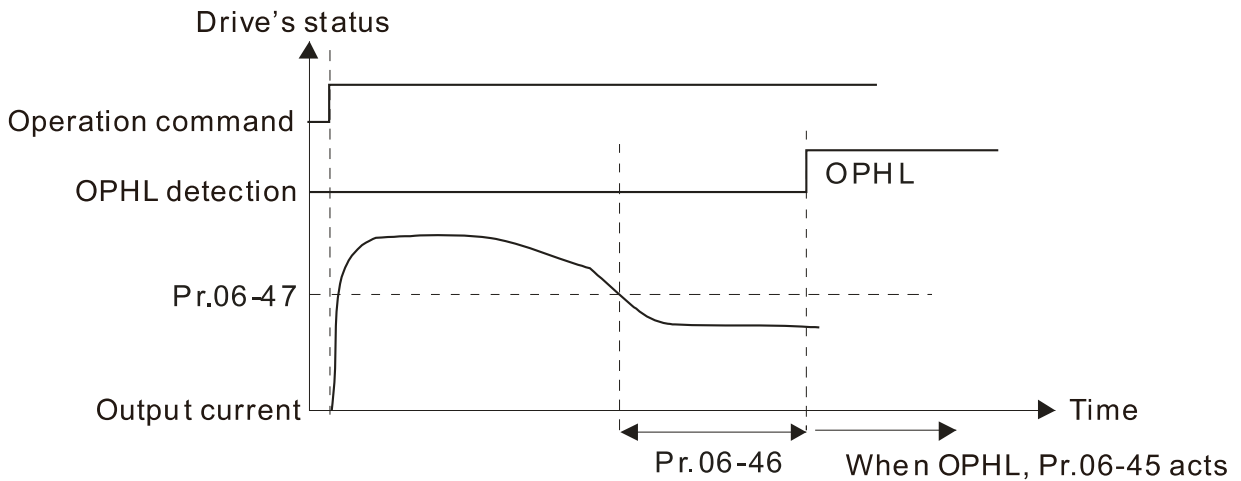

📖 Status 2: The drive is in STOP; Pr. 06-48 = 0 ; Pr. 07-02 ≠ 0

After the drive starts, the DC brake operates according to Pr. 07-01 and Pr. 07-02. During this period, OPHL detection is not active. After the DC brake action is completed, the drive starts to run, and enables the OPHL protection as mentioned above for status 1.

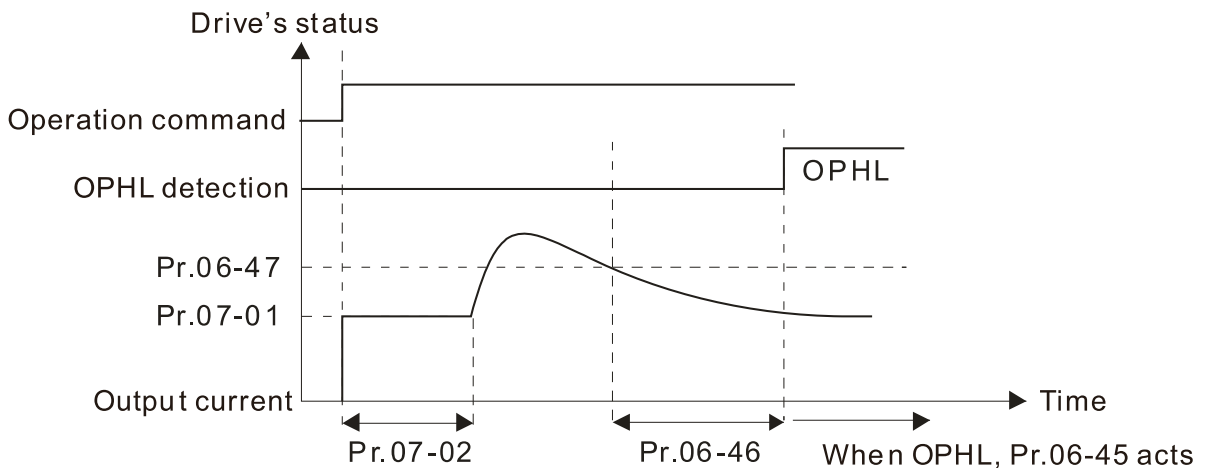

📖 Status 3: The drive is in STOP; Pr. 06-48 ≠ 0; Pr. 07-02 ≠ 0

When the drive starts, it executes Pr. 06-48 first, and then executes Pr. 07-02 (DC brake). The DC brake current level in this state includes two parts: one is 20 times the Pr. 06-47 setting value in Pr. 06-48 setting time; the other is the Pr. 07-01 setting value in Pr. 07-02 setting time. In this period, if an OPHL happens within the time for Pr. 06-48, the drive executes the Pr. 06-45 setting after the drive starts counting for half the time of Pr. 06-48.

Status 3-1: Pr. 06-48 ≠ 0, Pr. 07-02 ≠ 0 (No OPHL detected before operation)

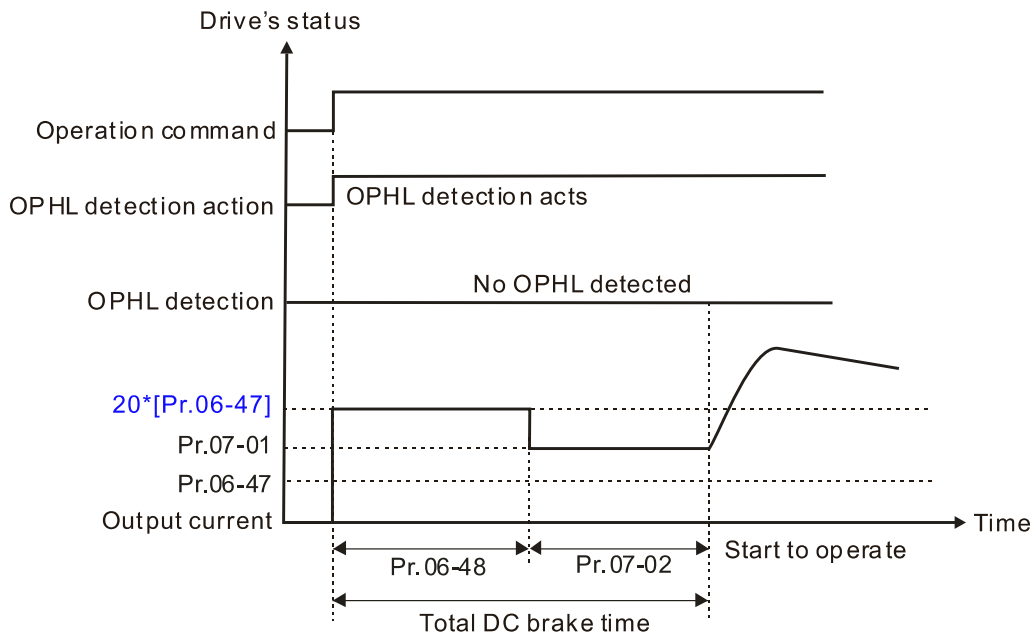

Status 3-2: Pr. 06-48≠0, Pr. 07-20≠0 (OPHL detected before operation)

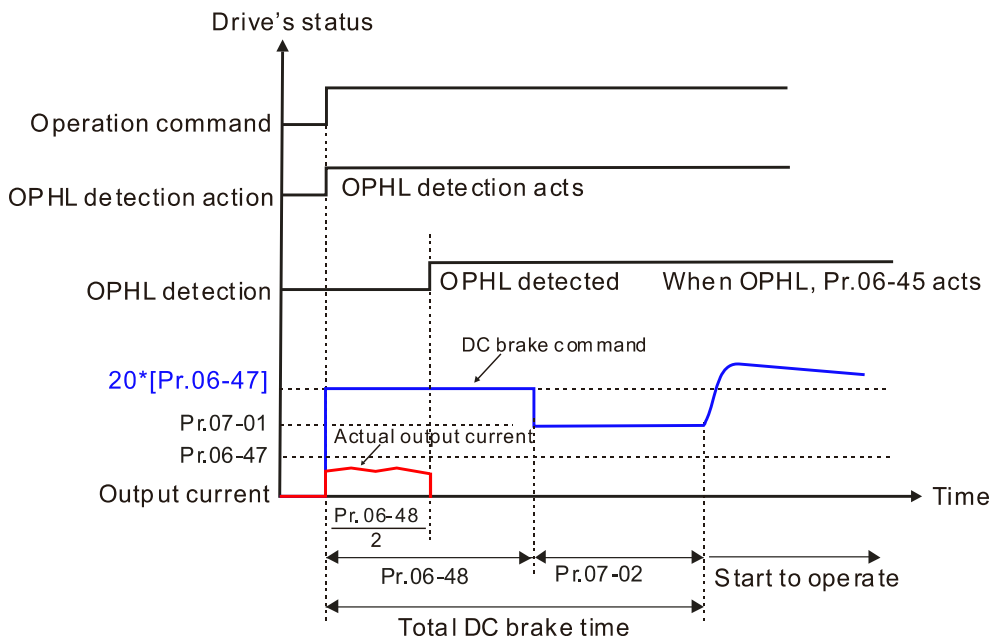

📖 Status 4: The drive is in STOP; Pr. 06-48 ≠ 0; Pr. 07-02 = 0

When the drive starts, it executes Pr. 06-48 as the DC brake. The DC brake current level is 20 times the Pr. 06-47 setting value. In this period, if an OPHL happens within the time for Pr. 06-48, the drive executes the Pr. 06-45 setting after the drive starts counting for half the time of Pr.06-48.

Status 4-1: Pr. 06-48 ≠ 0, Pr. 07-02 = 0 (No OPHL detected before operation)

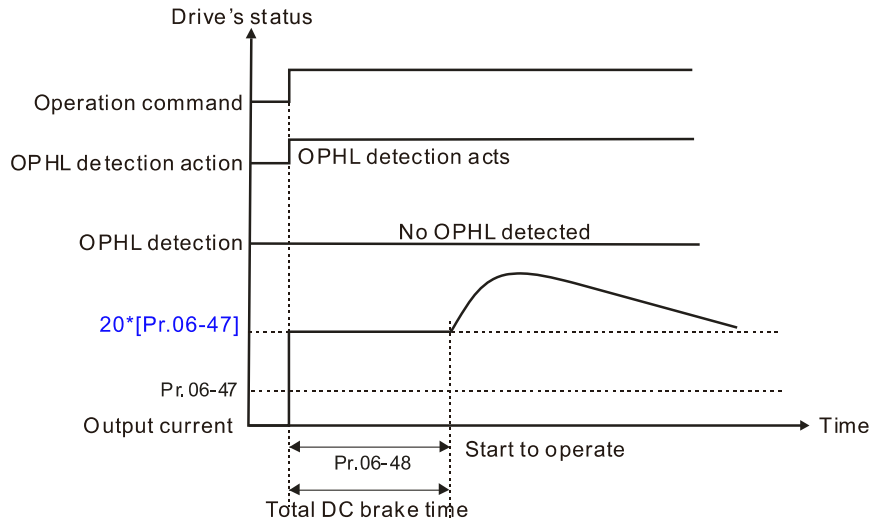

Status 4-2: Pr. 06-48 ≠ 0, Pr. 07-02 = 0 (OPHL detected before operation)

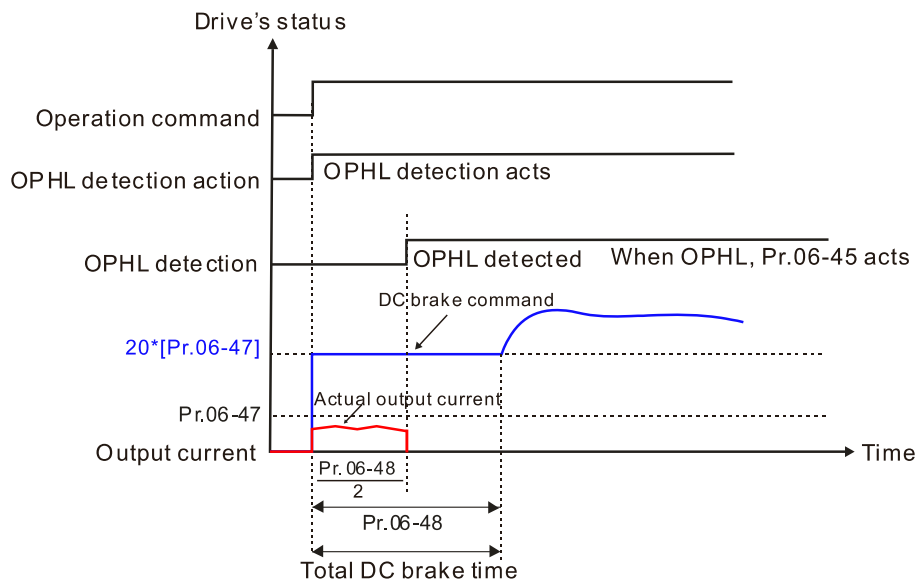

⚡ **06-49** LvX Auto-reset Default: 0

Settings 0: Disable  
1: Enable

⚡ **06-50** Time for Input Phase Loss Detection Default: 0.20

Settings 0.00–600.00 sec.

**06-51** Capacitor oH Warning Level

Default: Depending  
on the model power

Settings 0.0–110.0 degree

 Sets the over-heat warning level of the drive's internal DCBUS capacitor.

 When the setting is less than 10.0 degree, the drive uses its internal capacitor oH warning level.

**06-52** Ripple of Input Phase Loss

Default:  
30.0/60.0/75.0/90.0

Settings 230V series: 0.0–160.0 V<sub>DC</sub>

460V series: 0.0–320.0 V<sub>DC</sub>

575V series: 0.0–400.0 V<sub>DC</sub>

690V series: 0.0–480.0 V<sub>DC</sub>

**06-53** Detected Input Phase Loss (OrP) Action

Default: 0

Settings 0: Warn and ramp to stop

1: Warn and coast to stop

 When the drive detects the DC BUS ripple exceeds the setting for Pr. 06-52, and lasts for the time of Pr. 06-50 plus 30 seconds, the drive executes the input phase loss protection according to Pr. 06-53.

 During the time of Pr. 06-50 plus 30 seconds, if the DCBUS ripple drops lower than the setting for Pr. 06-52, the Orp protection recalculates.

**06-55** Derating Protection

Default: 0

Settings 0: Constant rated current and limit carrier wave by load current and temperature

1: Constant carrier frequency and limit load current by setting carrier wave

2: Constant rated current (same as setting 0), but close current limit

 The maximum output frequency and its corresponded carrier frequency lower limit under each control mode:

- VF, SVC and VFPG: 600Hz, 6K
- FOCPG: 600Hz, 12K
- FOC sensorless (IM): 300Hz, 6K
- FOC sensorless (PM): 500Hz, 10K

 Setting 0:

When the operating point is greater than the derating curve, the rated current is constant, and carrier frequency (Fc) output by the drive decreases automatically according to the ambient temperature, overload output current and overload time. If overloads are not frequent, and the concern is only about the carrier frequency operating with the rated current for a long time, and changes to the carrier wave due to short overload are acceptable, set to 0.

Refer to Section 9-7 “Derating Curve of Ambient Temperature” for the level of carrier frequency. Take VFD007C43A Normal Duty for example: ambient temperature 50°C, UL Open Type, and independent installation. When the carrier frequency is set to 15kHz, it corresponds to 75% of the rated output current. When the output current is higher than this value, it automatically decreases the carrier wave according to the ambient temperature, output current and overload time. At this time, the overload capacity of the drive is still 120% of the rated current.

 Setting 1:

When the operating point exceeds derating curve 1, the carrier frequency is fixed to the set value. Select this mode if the change of carrier wave and motor noise caused by ambient temperature and frequent overload are not acceptable. Refer to Pr.00-17.

Refer to Section 9-7 “Derating Curve of Ambient Temperature” for the derating level of the rated current. Take VFD007C43A Normal Duty for example, when the carrier frequency maintains at 15kHz, the rated current decreases to 72%. The oL protection executes when the current is  $120\% \times 72\% = 86\%$  for one minute; therefore, it must operate by the curve to keep the carrier frequency.

 Setting 2:

The protection method and action are the same as setting it to 0, but this disables the current limit when output current is the derating ratio  $\times 180\%$  (default value). The advantage is that this can provide a higher starting output current when the carrier frequency setting is higher than the default. The disadvantage is that the carrier wave derates easily when it overloads.

Example: when Pr. 06-55 = 0 or 1, over-current stall prevention level = ratio \* Pr. 06-03. When Pr. 06-55 = 2, the over-current stall prevention level = Pr. 06-03.

 Use with the settings for Pr. 00-16 and Pr. 00-17.

 The ambient temperature also affects the derating; refer to Section 9-7 “Ambient Temperature Derating Curve”. Take VFD007C43A Normal Duty for example, ambient temperature 50°C, UL Open Type, and independent installation. When the carrier frequency is set to 15kHz, it corresponds to 72% of the rated output current. The ambient temperature 60°C corresponds to  $72\% \times 80\%$  of the rated output current.

 **06-56** PT100 Voltage Level 1 Default: 5.000  
 Settings 0.000–10.000 V

 **06-57** PT100 Voltage Level 2 Default: 7.000  
 Settings 0.000–10.000V

 Condition settings: Pr. 06-57 > Pr. 06-56.

 **06-58** PT100 Level 1 Frequency Protection Default: 0.00  
 Settings 0.00–599.00 Hz

06-59 PT100 Activation Level 1 Protection Frequency Delay Time

Default: 60

Settings 0–6000 sec.

PT100 operation instructions

- (1) Use voltage type analog input (AVI, AUI, and ACI voltage 0–10 V) and select PT100 mode.
- (2) Select one of the voltage type analog inputs below: (a) AVI (Pr. 03-00=11), (b) AUI (Pr. 03-02=11), or (c) ACI (Pr. 03-01=11 and Pr. 03-29=1).
- (3) When selecting Pr. 03-01 = 11 and Pr. 03-29 = 1, you must switch SW4 to 0–10V for the external I/O board.
- (4) The AFM2 outputs constant voltage or current, then Pr. 03-23 = 23. You must switch AFM2 SW2 to 0–20mA for the external I/O board, and set AFM2 output level to 45% (Pr. 03-33 = 45%) of 20 mA = 9 mA.
- (5) Use Pr. 03-33 to adjust the constant voltage or constant current of the AFM2 output; the setting range is 0–100.00%.
- (6) There are two types of action levels for PT100. The diagram below shows the PT100 protecting action.

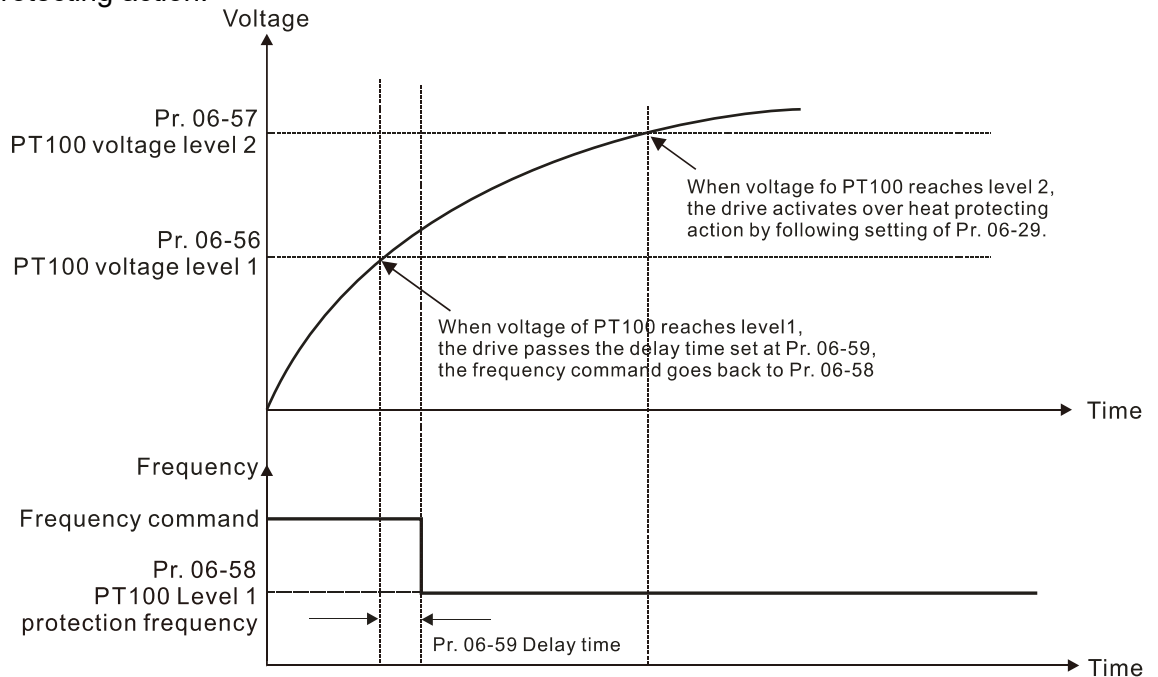

(7) PT100 wiring diagram:

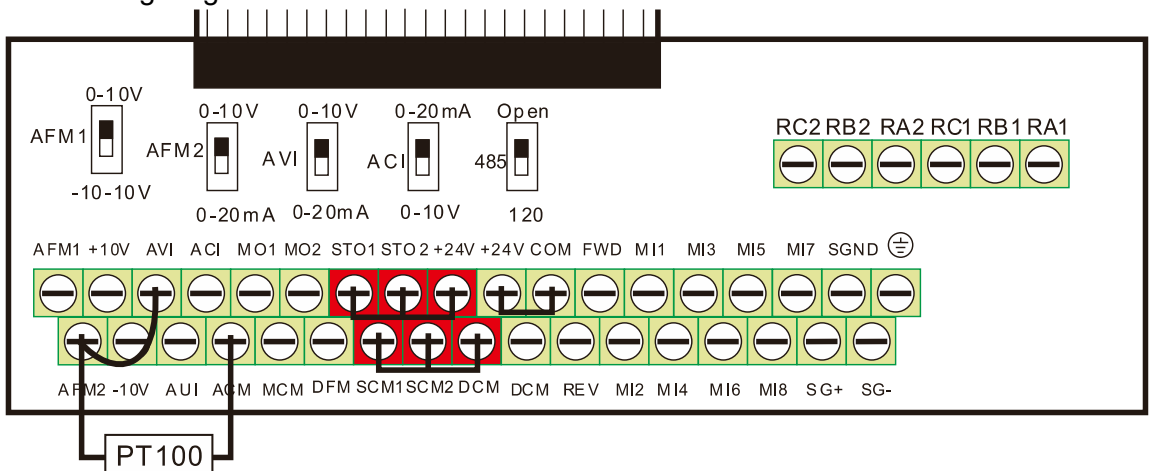



Figure 1

 When Pr. 06-58 = 0.00Hz, PT100 function is disabled.

Example:

When using PT100, if the motor temperature is higher than 135°C (275°F), the drive starts to count the delay time for auto-deceleration (Pr. 06-59). The drive decreases the motor frequency to the setting for Pr. 06-58 when it reaches the delay time count value. The drive operates at the frequency set for Pr.06-58 until the motor temperature is lower than 135°C (275°F). If the motor temperature is higher than 150°C (302°F), the drive automatically decelerates to STOP and displays the warning “oH3”.

Set up process:

1. Switch AFM2 to 0–20mA on the I/O control terminal block. (Refer to Figure 1, PT100 wiring diagram)
2. Wiring (Refer to Figure 1, PT100 wiring diagram):  
 Connect external terminal AFM2 to (+)  
 Connect external terminal ACM to (-)  
 Connect external terminals AFM2 and AVI to “short-circuit”
3. Set Pr. 03-00 = 11, Pr. 03-23 = 23 or Pr. 03-33 = 45% (9mA)
4. Refer to the RTD temperature and resistance comparison table  
 Temperature = 135°C, resistance = 151.71Ω; input current: 9mA, voltage: about 1.37V<sub>DC</sub>  
 Temperature = 150°C, resistance = 157.33Ω; input current: 9mA, voltage: about 1.42V<sub>DC</sub>
5. When the RTD temperature > 135°C, the drive decelerates to the specified operation frequency automatically. Then, Pr. 06-56 = 1.37 and Pr. 06-58 = 10 Hz. When Pr. 06-58 = 0, it disables the specified operation frequency.
6. When the RTD temperature > 150°C, the drive outputs a fault, decelerates to STOP, and displays the warning “oH3”. Then, Pr. 06-57 = 1.42 and Pr. 06-29 = 1 (warn and ramp to stop).

 **06-60** Software Detection GFF Current Level Default: 60.0

Settings 0.0–6553.5 %

 **06-61** Software Detection GFF Filter Time Default: 0.10

Settings 0.00–655.35 sec.

 When the drive detects that the unbalanced three-phase output current is higher than the setting for Pr. 06-60, GFF protection activates. The drive then stops output.

 **06-62** dEb Reset Bias Level Default: 20.0 / 40.0

Settings 230V series: 0.0–100.0 V<sub>DC</sub>  
 460V series: 0.0–200.0 V<sub>DC</sub>

 Prevents action vibration caused by dEb action level = reset level. dEb active level + Pr. 06-62 = dEb reset bias level.

<b>06-63</b>	Operation Time of Fault Record 1 (Day)
<b>06-65</b>	Operation Time of Fault Record 2 (Day)
<b>06-67</b>	Operation Time of Fault Record 3 (Day)
<b>06-69</b>	Operation Time of Fault Record 4 (Day)

Default: Read only

Settings 0–65535 days

<b>06-64</b>	Operation Time of Fault Record 1 (Min.)
<b>06-66</b>	Operation Time of Fault Record 2 (Min.)
<b>06-68</b>	Operation Time of Fault Record 3 (Min.)
<b>06-70</b>	Operation Time of Fault Record 4 (Min.)

Default: Read only

Settings 0–1439 min.

📖 If there is any malfunctions when the drive operates, Pr. 06-17–Pr. 06-22 records the malfunctions, and Pr. 06-63–Pr. 06-70 records the operation time for four sequential malfunctions. Check if there is any problem with the drive according to the interval of the recorded fault.

Example:

The first error: ocA occurs after motor drive operates for 1000 minutes.

The second error: ocd occurs after another 1000 minutes.

The third error: ocn occurs after another 1000 minutes.

The fourth error: ocA occurs after another 1000 minutes.

The fifth error: ocd occurs after another 1000 minutes.

The sixth error: ocn occurs after another 1000 minutes.

Then Pr.06-17–06-22 and Pr.06-63–06-70 are recorded as follows:

	1 <sup>st</sup> fault	2 <sup>nd</sup> fault	3 <sup>rd</sup> fault	4 <sup>th</sup> fault	5 <sup>th</sup> fault	6 <sup>th</sup> fault
Pr.06-17	ocA	ocd	ocn	ocA	ocd	ocn
Pr.06-18	0	ocA	ocd	ocn	ocA	ocd
Pr.06-19	0	0	ocA	ocd	ocn	ocA
Pr.06-20	0	0	0	ocA	ocd	ocn
Pr.06-21	0	0	0	0	ocA	ocd
Pr.06-22	0	0	0	0	0	ocA
Pr.06-63	0	1	2	2	3	4
Pr.06-64	1000	560	120	1120	680	240
Pr.06-65	0	0	1	2	2	3
Pr.06-66	0	1000	560	120	1120	680
Pr.06-67	0	0	0	1	2	2
Pr.06-68	0	0	1000	560	120	1120
Pr.06-69	0	0	0	0	1	2
Pr.06-70	0	0	0	1000	560	120

※By examining the time record, you can see that that the last fault (Pr.06-17) happened after the drive ran for 4 days and 240 minutes.



⚡ **06-71** Low Current Setting Level Default: 0.0

Settings 0.0–100.0 %

⚡ **06-72** Low Current Detection Time Default: 0.00

Settings 0.00–360.00 sec.

⚡ **06-73** Low Current Action Default: 0

- Settings
- 0: No function
  - 1: Warn and coast to stop
  - 2: Warn and ramp to stop by the 2<sup>nd</sup> deceleration time
  - 3: Warn and continue operation

- 📖 The drive operates according to the setting for Pr. 06-73 when the output current is lower than the setting for Pr. 06-71 and when the time of the low current exceeds the detection time for Pr. 06-72. Use this parameter with the external multi-function output terminal 44 (for low current output).
- 📖 The low current detection function does not execute when drive is in sleep or standby status.
- 📖 Sets Pr. 06-71 low current level according to the drive's rated current, the equation is  $\text{Pr. 00-01 (drive's rated current)} \times \text{Pr. 06-71 (low current setting level)\%} = \text{low current detection level (A)}$ . The drive changes the setting for Pr. 00-01 (rated current) according to the setting for Pr. 00-16 (load selection).

⚡ **06-86** PTC Type Default: 0

- Settings
- 0: PTC
  - 1: KTY84-130

- 📖 When using KTY84-130, a divider resistance (2kΩ , power > 1/4W, ±0.1%) is needed.
- 📖 Wiring diagram is as below:

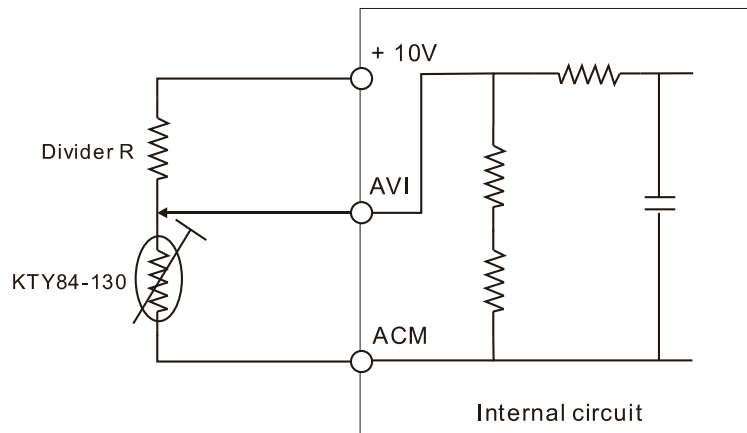

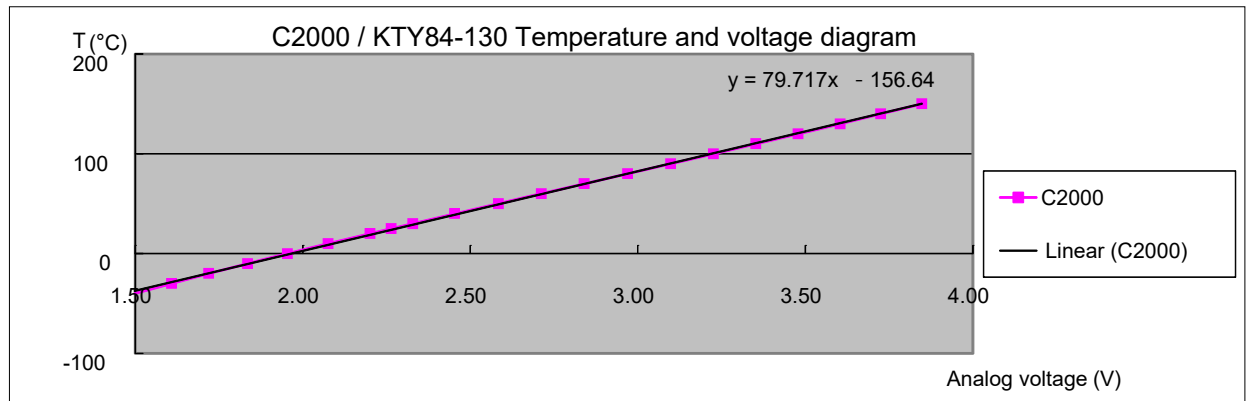

- 📖 When the temperature exceeds the setting level, an oH3 error occurs to the drive. Reset conditions: when the temperature is below the trigger level  $-5^{\circ}\text{C}$ , the oH3 error is cleared.
- 📖 When the KTY is not connected, or the KTY is burned, the calculated temperature is beyond  $-40$ – $150^{\circ}\text{C}$ , the temperature is displayed as its lower limit ( $-40^{\circ}\text{C}$ ) or upper limit ( $150^{\circ}\text{C}$ ) without additional error information. At this time, the drive still trips up the oH3 error, check if the installation is correct.
- 📖 When the temperature detection warning occurs to the KTY-84, select the action according to Pr. 06-29.

## 07 Special Parameters

✎ This parameter can be set during operation.

### ✎ 07-00 Software Brake Level

Default:

370.0/740.0/895.0/1057.0

Settings 230V series: 350.0–450.0 V<sub>DC</sub>  
 460V series: 700.0–900.0 V<sub>DC</sub>  
 575V series: 850.0–1116.0 V<sub>DC</sub>  
 690V series: 939.0–1318.0 V<sub>DC</sub>

📖 Sets the brake transistor level for the DC BUS voltage. Choose a suitable brake resistor to achieve the best deceleration. Refer to Chapter 7 Optional Accessories for information about brake resistors.

📖 This parameter is only valid for the models below 30kW of 460 series and 22kW of 230 series.

### ✎ 07-01 DC Brake Current Level

Default: 0

Settings 0–100%

📖 Sets the level of the DC brake current output to the motor during start-up and stop. When you set the DC brake current percentage, the rated current is regarded as 100%. Start with a low DC brake current level, and increase it slowly until the proper brake torque is reached. However, to avoid burning the motor, the DC brake current can NOT exceed the rated current. Therefore, DO NOT use the DC brake for mechanical retention, otherwise injury or accident may occur.

📖 The PM has the magnetic field itself, using the DC brake may possibly cause the motor run in a reverse direction, therefore, it is not recommended to use DC brake for PM.

### ✎ 07-02 DC Brake Time at RUN

Default: 0.0

Settings 0.0–60.0 sec.

📖 The motor may continue rotating after the drive stops output due to external forces or the inertia of the motor itself. If you use the drive with the motor rotating, it may cause motor damage or trigger drive protection due to over-current. This parameter outputs DC current, generating torque to force the motor stop to get a stable start before motor operation. This parameter determines the duration of the DC brake current output to the motor when the drive starts up. Setting this parameter to 0.0 disables the DC brake at start-up.

📖 The PM has the magnetic field itself, using the DC brake may possibly cause the motor run in a reverse direction, therefore, it is not recommended to use DC brake for PM. Use Pr. 10-49 zero voltage command to force the motor decelerate or to stop.

### ✎ 07-03 DC Brake Time at STOP

Default: 0.0

Settings 0.0–60.0 sec.

📖 The motor may continue rotating after the drive stops output due to external forces or the inertia of the motor itself. This parameter outputs DC current, generating torque to force the drive stop after the drive stops output to make sure that the motor stops.

📖 This parameter determines the duration of the DC brake current output to the motor when braking. To enable DC brake at STOP, set Pr. 00-22 (Stop Method) to 0 (ramp to stop). The DC brake is invalid when Pr. 07-03 is set to 0.0.

📖 Related parameters: Pr. 00-22 Stop Method, Pr. 07-04 DC Brake Frequency at STOP.

### 🚩 **07-04** DC Brake Frequency at STOP

Default: 0.00

Settings 0.00–599.00 Hz

📖 This parameter determines the start frequency of the DC brake before the drive ramps to stop. When this setting is less than Pr.01-09 (Start-up Frequency), the start frequency of the DC brake starts from the minimum frequency.

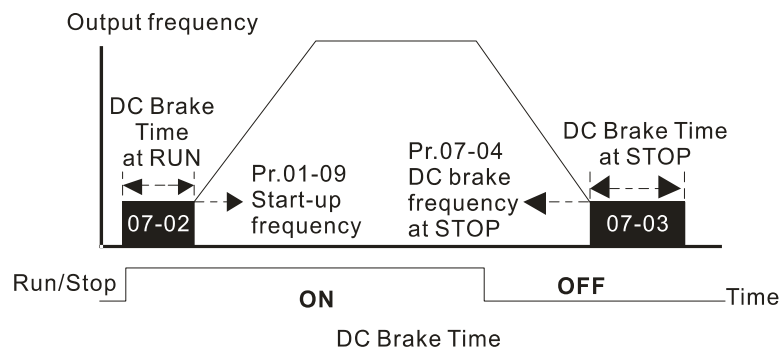

📖 Use the DC brake before running the motor when the load is movable at stop, such as with fans and pumps. The motor is in free operating status and in unknown rotation direction before the drive starts up. Execute the DC brake before you start the motor.

📖 Use DC Brake at STOP when you need to brake the motor quickly or to control the positioning, such as with cranes or cutting machines.

### 🚩 **07-05** Voltage Increasing Gain

Default: 100

Settings 1–200%

📖 When using speed tracking, adjust Pr. 07-05 to slow down the increasing voltage gain if there are errors such as oL or oc; however, the speed tracking time will be longer.

### 🚩 **07-06** Restart after Momentary Power Loss

Default: 0

Settings 0: Stop operation

1: Speed tracking by speed before the power loss

2: Speed tracking by minimum output frequency

📖 Determines the operation mode when the drive restarts from a momentary power loss.

📖 The power system connected to the drive may power off momentarily due to many reasons. This function allows the drive to keep outputting after the drive is repowered and does not cause the drive to stop.

📖 Setting 1: Frequency tracking begins before momentary power loss and accelerates to the master Frequency command after the drive output frequency and motor rotator speed are synchronous. Use this setting when there is a lot of inertia with little resistance on the motor load.

For example, in equipment with a large inertia flywheel, there is NO need to wait until the flywheel stops completely after a restart to execute the operation command; therefore, it saves time.

- 📖 Setting 2: Frequency tracking starts from the minimum output frequency and accelerates to the master Frequency command after the drive output frequency and motor rotator speed are synchronous. Use this setting when there is little inertia and large resistance.
- 📖 In PG control mode, the AC motor drive executes the speed tracking function automatically according to the PG speed when this setting is NOT set to 0.
- 📖 This function is only valid when the RUN command is enabled.

↗ **07-07** Allowed Power Loss Duration Default: 2.0

Settings 0.0–20.0 sec.

- 📖 Determines the maximum time of allowable power loss. If the duration of a power loss exceeds this parameter setting, the AC motor drive stops output.
- 📖 Pr.07-06 is valid when the maximum allowable power loss time is  $\leq 20$  seconds and the AC motor drive displays “Lv”. If the AC motor drive is powered off due to overload, even if the maximum allowable power loss time is  $\leq 20$  seconds, the operation mode set in Pr.07-06 does not execute.

↗ **07-08** Base block Time Default: Depending on the model power

Settings 0.0–5.0 sec.

- 📖 When momentary power loss is detected, the AC motor drive blocks its output and then waits for a specified period of time (determined by Pr. 07-08, called Base Block Time) before resuming operation. Set this parameter to the time that allows the residual voltage at the output side to decrease to 0 V before activating the drive again.
- 📖 This parameter is not only for the B.B. time, but also is the re-start delay time after free run.
- 📖 The RUN command during a free run operation is memorized, and runs or stops with the last frequency command after the delay time.
- 📖 This delay time is only applicable in “Re-start after coast to stop” status, and does not limit ramp to stop. The coast to stop can be caused by various control command source, or by errors.
- 📖 Following table is the recommended setting for re-start delay time of each model power. You must set Pr. 07-08 according to this table (the default of each model power is based on this table as well).

kW	007	015	022	037	055	075	110	150	185	220	300	370	450	550	750	900
HP	1	2	3	5	7.5	10	15	20	25	30	40	50	60	75	100	120
Delay time (sec.)	0.3	0.4	0.5	0.6	0.7	0.8	0.9	1	1.1	1.2	1.3	1.4	1.5	1.6	1.7	1.8

kW	1100	1320	1600	1850	2200	2800	3150	3550	4000	5000
HP	150	175	215	250	300	375	425	475	536	650
Delay time (sec.)	1.9	2	2.1	2.2	2.3	2.4	2.5	2.6	2.7	2.8

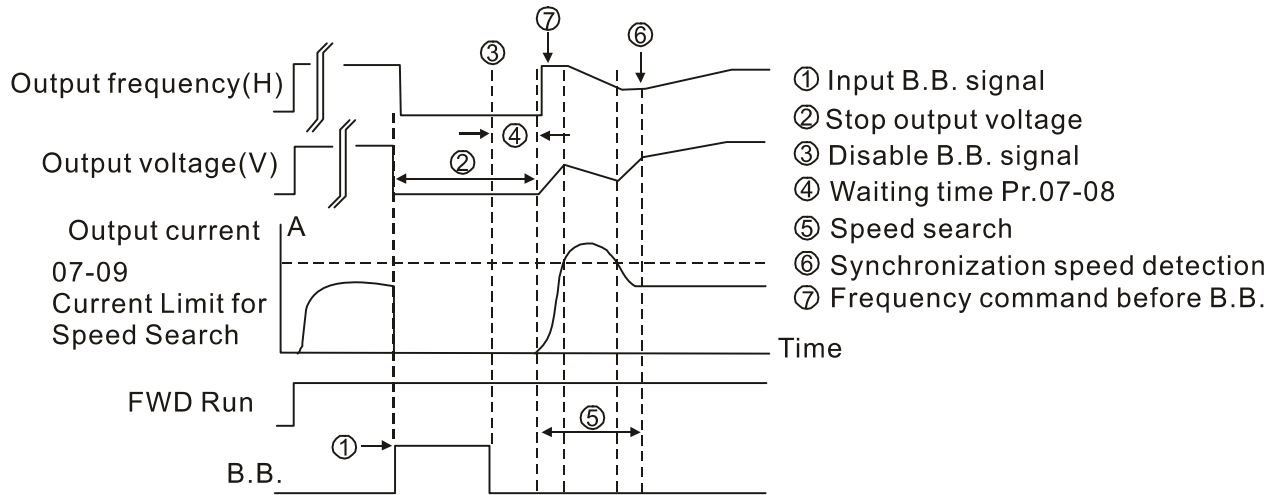

B.B. Search with last output frequency downward timing chart

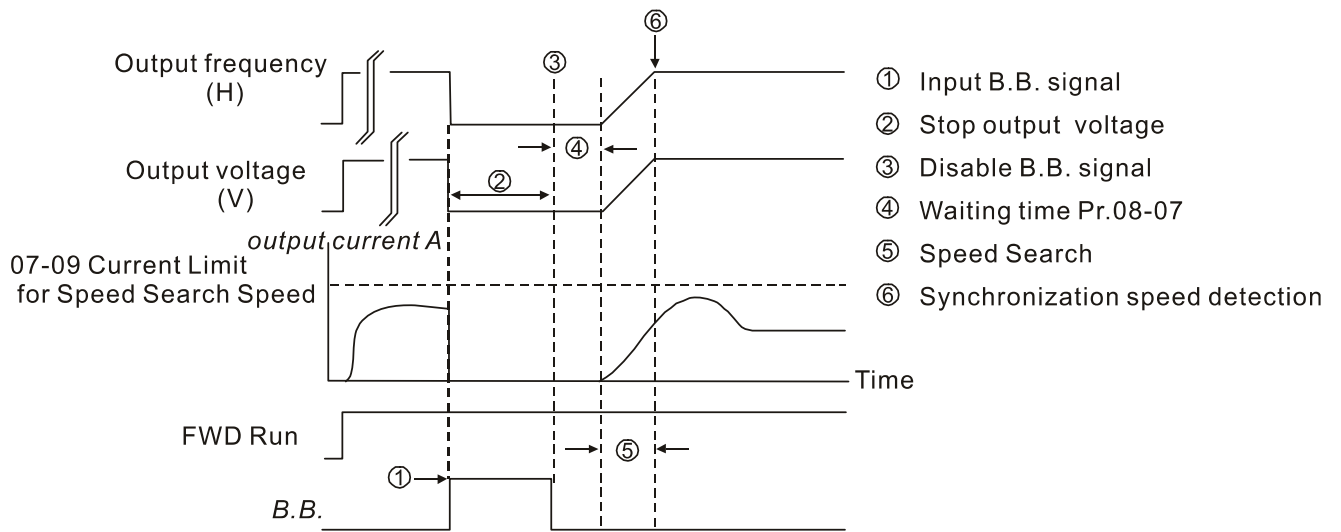

B.B. Search with minimum output frequency upward timing chart

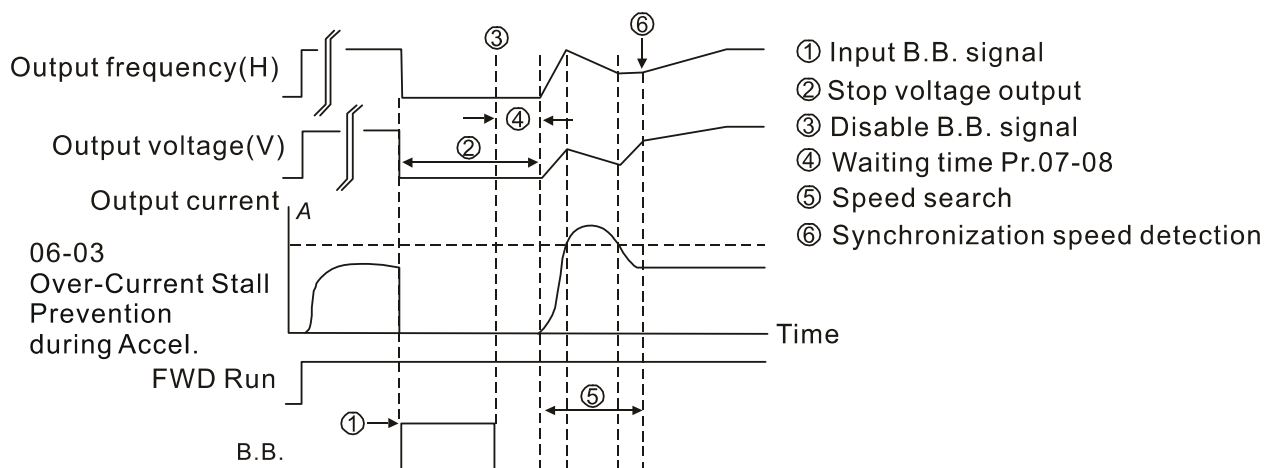

B.B. Search with minimum output frequency upward timing chart

### ↗ **07-09** Current Limit of Speed Tracking

Default: 100

Settings 20–200%

- 📖 The AC motor drive executes speed tracking only if the output current is greater than the value set in Pr. 07-09.
- 📖 The maximum current for speed tracking affects the synchronous time. The larger the parameter setting is, the faster the synchronization occurs. However, if the parameter setting is too large, the overload protection function may be activated.

### ↗ **07-10** Restart after Fault Action

Default: 0

Settings 0: Stop operation  
 1: Speed tracking by current speed  
 2: Speed tracking by minimum output frequency

- 📖 In PG control mode, the AC motor drive executes the speed tracking function automatically according to the PG speed when this setting is NOT set to 0.
- 📖 Faults include: bb, oc, ov and occ. To restart after oc, ov and occ, you can NOT set Pr. 07-11 to 0.

### ↗ **07-11** Number of Times of Restart after Fault

Default: 0

Settings 0–10

- 📖 After fault (oc, ov and occ) occurs, the AC motor drive can reset and restart automatically up to 10 times. When Pr. 07-11 is set to 0, the auto-reset / restart function is disabled after fault. The drive re-starts according to the setting for Pr. 07-10.
- 📖 If the number of faults exceeds the Pr. 07-11 setting, the drive does not reset and restart until you press “RESET” manually and execute the operation command again.

### ↗ **07-12** Speed Tracking during Start-up

Default: 0

Settings 0: Disable  
 1: Speed tracking by maximum output frequency  
 2: Speed tracking by motor frequency at start  
 3: Speed tracking by minimum output frequency

- 📖 Speed tracking is suitable for punch, fans and other large inertia loads. For example, a mechanical punch usually has a large inertia flywheel, and the general stop method is coast to stop. If it needs to be restarted again, the flywheel may take 2–5 minutes or longer to stop. This parameter setting allows you to start the flywheel operating again without waiting until the flywheel stops completely. If you can use the speed feedback function (PG + Encoder), this speed tracking function will be faster and more accurate. Set Pr. 07-09 as the target of the output current (the maximum current of speed tracking).
- 📖 In PG control mode, the AC motor drive executes the speed tracking function automatically according to the PG speed when this setting is NOT set to 0.

When using PM, Pr. 07-12  $\neq$  0, the speed tracking function is enabled. When Pr. 07-12 = 1, 2 or 3, the output frequency converts to the actual rotor speed from zero-speed.

## 07-13 dEb Function Selection

Default: 0

Settings 0: Disable

1: dEb with auto-acceleration / auto-deceleration, the drive does not output the frequency after the power is restored.

2: dEb with auto acceleration / auto-deceleration, the drive outputs the frequency after the power is restored.

3: dEb low-voltage control, then increase to  $350V_{DC} / 700V_{DC}$  and decelerate to stop

4: dEb high-voltage control of  $350V_{DC} / 700V_{DC}$  and decelerate to stop

dEb (Deceleration Energy Backup) lets the motor decelerate to stop when momentary power loss occurs. When the power loss is instantaneous, use this function to let the motor decelerate to zero speed. If the power recovers at this time, the drive restarts the motor after the dEb return time.

Lv return level: Default value depends on the drive power model

Frame A, B, C, D = Pr. 06-00 + 60V/30V (230V series)

Frame E and above = Pr. 06-00 + 80V/40V (230V series)

Lv level: Default = Pr. 06-00

During dEb operation, other protection such as ryF, ov, oc, occ and EF may interrupt it, and these error codes are recorded.

The STOP (RESET) command does not work during the dEb auto-deceleration, and the drive continues decelerating to stop. To make the drive coast to stop immediately, use another function (EF) instead.

The B.B. function does not work when executing dEb. The B.B. function is enabled after the dEb function finishes.

Even though the Lv warning does not display during dEb operation, if the DC BUS voltage is lower than the Lv level, MOx = 10 (Low voltage warning) still operates.

The following explains the dEb action:

When the DC voltage drops below the dEb setting level, the dEb function starts to work (soft start relay remains closed), and the drive executes auto-deceleration.

- Situation 1: Momentary power loss, or power current too low and unstable, or power supply sliding down because of sudden heavy load.

Pr. 07-13=1, "dEb active, DC BUS voltage returns, output frequency does not return" and power recovers.

When the power recovers and DC BUS voltage exceeds the dEb return level, the drive linearly decelerates to 0 Hz and stops. The keypad displays the "dEb" warning until you manually reset it, so that you can see the reason for the stop.



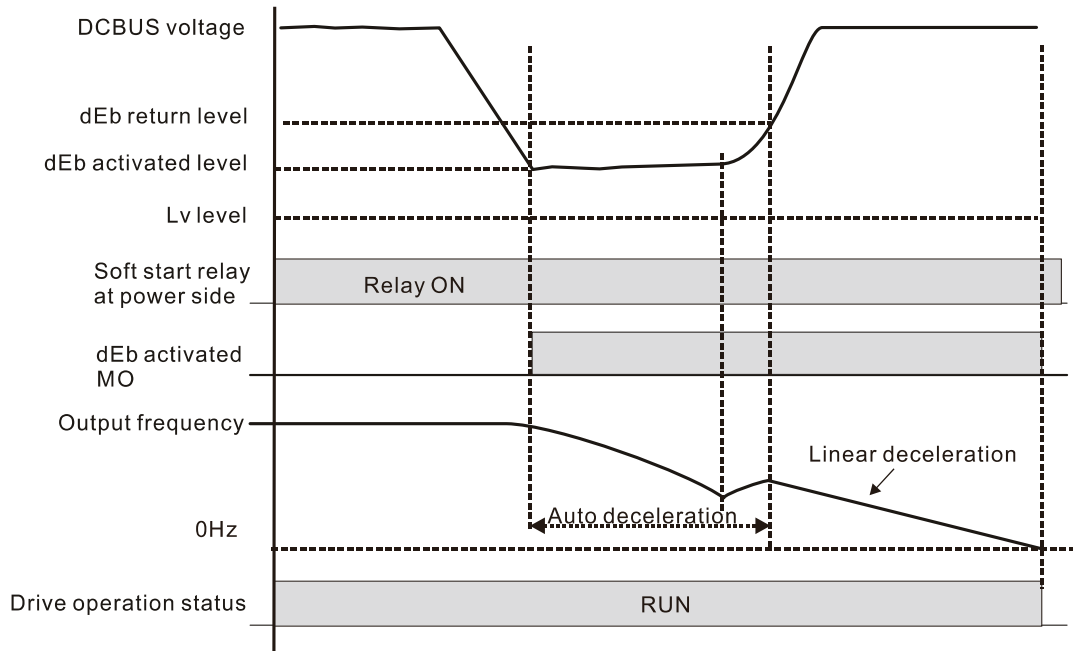

- Situation 2: Momentary power loss, or power current too low and unstable, or power supply sliding down because of sudden heavy load.

Pr. 07-13=2 “dEb active, DC BUS voltage returns, output frequency returns” and power recovers.

During the dEb deceleration (includes 0 Hz run), if the power recovers higher than dEb return level, the drive maintains the frequency for the set time of Pr. 07-14 (default = 3 sec.) and then accelerates again. The dEb warning on the keypad clears automatically.

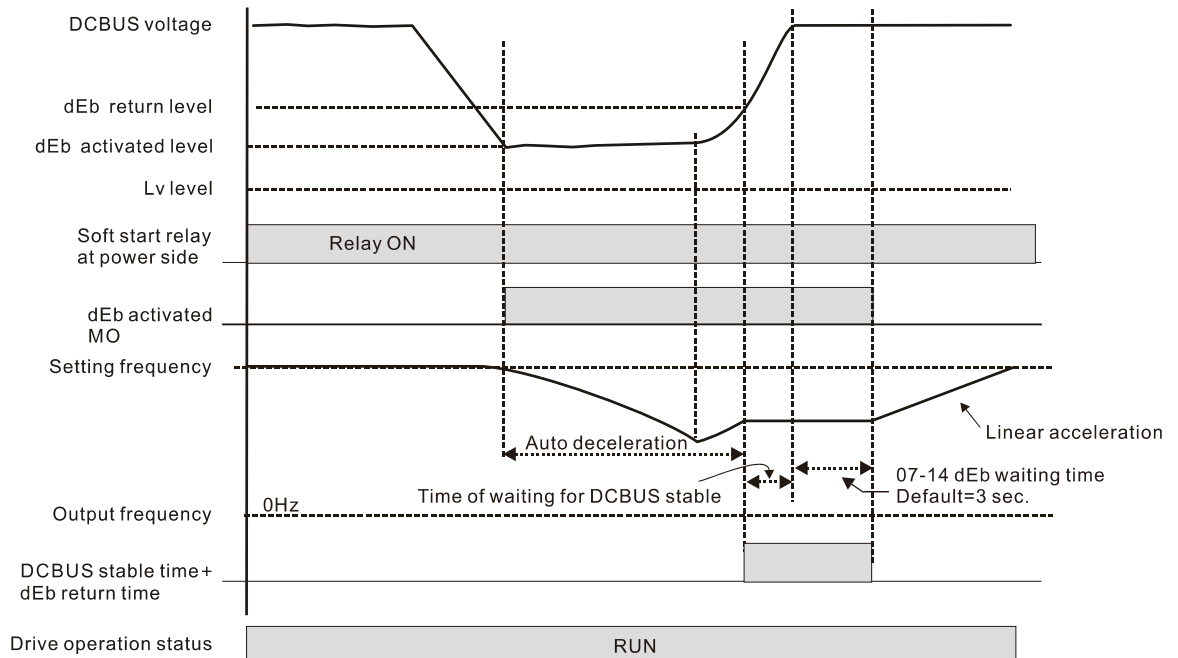

- Situation 3: Power supply unexpected shut down or power loss

Pr. 07-13=1 “dEb active, DC BUS voltage returns, the output frequency does not return” and the power does not recover.

The keypad displays the “dEb” warning and stops after decelerating to the lowest running frequency. When the DC BUS voltage is lower than the Lv level, the drive disconnects the soft start relay until the power completely runs out.

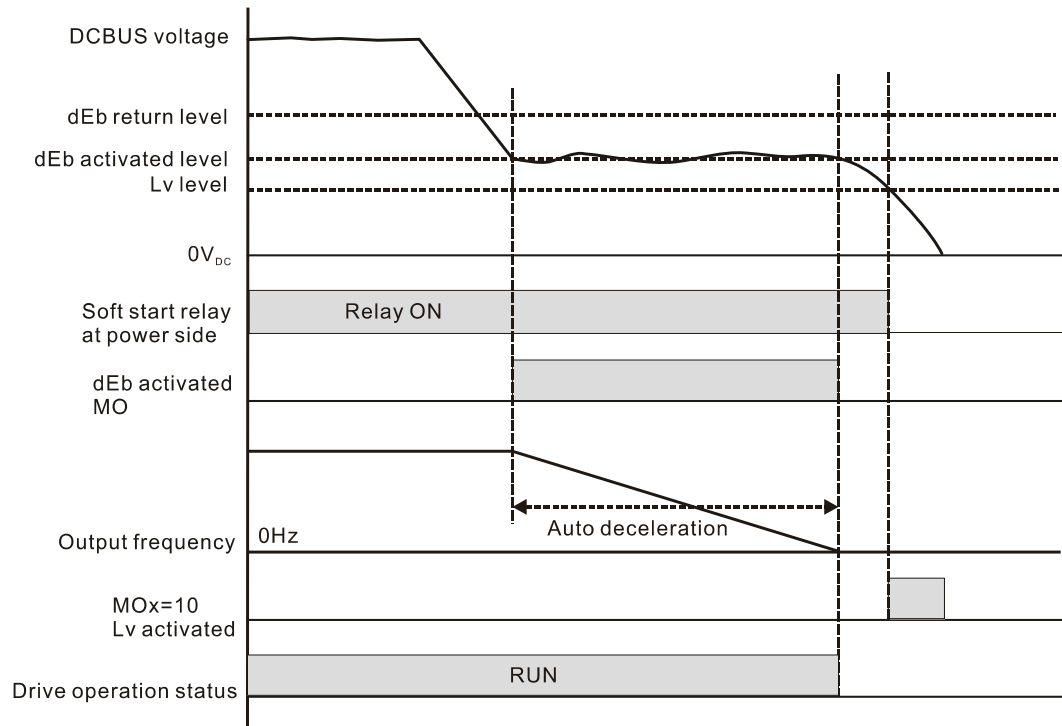

- Situation 4:

Pr. 07-13=2 “dEb active, DCBUS voltage returns, the output frequency returns” and power does not recover.

The drive decelerates to 0 Hz. The DC BUS voltage continues to decrease until the voltage is lower than the Lv level, and then the drive disconnects the soft start relay. The keypad displays “dEb” warning until the drive completely runs out of power.

- Situation 5:

Pr. 07-13=2 “dEb low voltage control, when the speed is lower than 1/4 rated motor speed, DCBUS voltage rises to 350V<sub>DC</sub> / 700V<sub>DC</sub>, the drive ramps to stop.

The drive decelerates to 0 Hz. The DC BUS voltage continues to decrease until the voltage is lower than the Lv level, and then the drive disconnects the soft start relay. The soft start relay closes again after the power recovers and the DC BUS voltage is higher than the Lv return level. When the DC BUS voltage is higher than the dEb return level, the drive maintains the frequency for the set time of Pr. 07-14 (default = 3 sec.) and starts to accelerate linearly, and the dEb warning on the keypad clears automatically.

- Situation 6:

Pr. 07-13=4, dEb high-voltage control

When dEb occurs, the DC BUS voltage control level rises to 350V<sub>DC</sub> / 700V<sub>DC</sub> to ramp to stop. Even though the power recovers and the frequency does not return, dEb activates until the motor decelerates to 0 Hz.

- (1) When dEb activates, it sends dEb warning. When the output frequency reaches 0Hz, the operation status is STOP and disables the dEb function, the dEb warning continues.
- (2) If power does not recover, the DC BUS voltage drops until reaches the Lv level, the drive LvS error occurs (keypad displays LvS error that covers the dEb display), the Soft Start Relay will be OFF.

↗ **07-14** dEb Function Reset Time Default: 3.0  
 Settings 0.0–25.0 sec.

📖 dEb (Deceleration Energy Backup) lets the motor decelerate to stop when momentary power loss occurs. When the power loss is instantaneous, use this function to let the motor decelerate to zero speed.

↗ **07-15** Dwell Time at Acceleration Default: 0.00  
 Settings 0.00–600.00 sec.

↗ **07-17** Dwell Time at Deceleration Default: 0.00  
 Settings 0.00–600.00 sec .

↗ **07-16** Dwell Frequency at Acceleration Default: 0.00  
 Settings 0.00–599.00 Hz

↗ **07-18** Dwell Frequency at Deceleration Default: 0.00  
 Settings 0.00–599.00 Hz

📖 In the heavy load situation, Dwell can make stable output frequency temporarily, such as crane or elevator.

📖 When the load is heavier, use Pr. 07-15–Pr. 07-18 to avoid ov or oc protection.

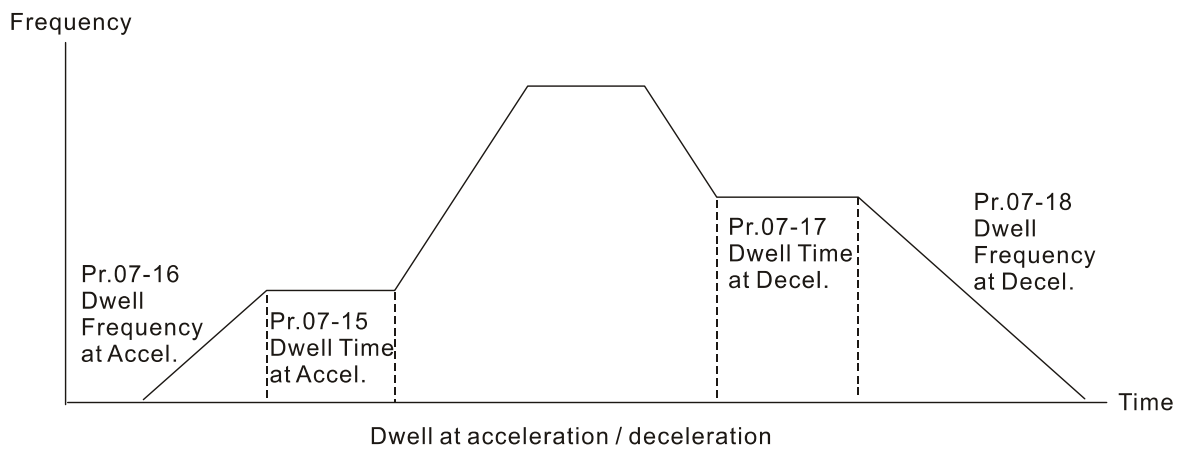

## 07-19 Fan Cooling Control

Default: 0

- Settings
- 0: Fan always ON
  - 1: Fan is OFF after AC motor drive stops for one minute
  - 2: Fan is ON when AC motor drive runs; fan is OFF when AC motor drive stops
  - 3: Fan turns ON when temperature (IGBT) reaches around 60°C
  - 4: Fan always OFF

 Use this parameter to control the fan.

 0: Fan runs immediately when the drive power is turned ON.

 1: Fan runs when AC motor drive runs. One minute after AC motor drive stops, the fan is OFF.

 2: Fan runs when AC motor drive runs and stops immediately when AC motor drive stops.

 3: When temperature of the IGBT or capacitance is higher than 60°C, the fan runs.

When temperature of the IGBT and capacitance are both lower than 40°C, the fan stops.

 4: Fan is always OFF

 The control parameters for the applicable fan of each frame are as below:

Frame	Heat Sink Fan	Capacitor Fan
A	Pr. 07-19	No capacitor fan
B	Pr. 07-19	Pr. 07-19
C	Pr. 07-19	Pr. 07-19 230V series: always ON
D0	Pr. 07-19	Pr. 07-19
D	Pr. 07-19	ON
E	Pr. 07-19	Pr. 07-19
F	Pr. 07-19	Pr. 07-19
G	Pr. 07-19	No capacitor fan
H	Pr. 07-19	No capacitor fan

## 07-20 Emergency Stop (EF) & Force to Stop Selection

Default: 0

- Settings
- 0: Coast to stop
  - 1: Stop by the 1<sup>st</sup> deceleration time
  - 2: Stop by the 2<sup>nd</sup> deceleration time
  - 3: Stop by the 3<sup>rd</sup> deceleration time
  - 4: Stop by the 4<sup>th</sup> deceleration time
  - 5: System deceleration
  - 6: Automatic deceleration

 When the multi-function input terminal is set to EF input (setting 10) or force to stop (setting 18) and the terminal contact is ON, the drive stops according to the setting of this parameter.

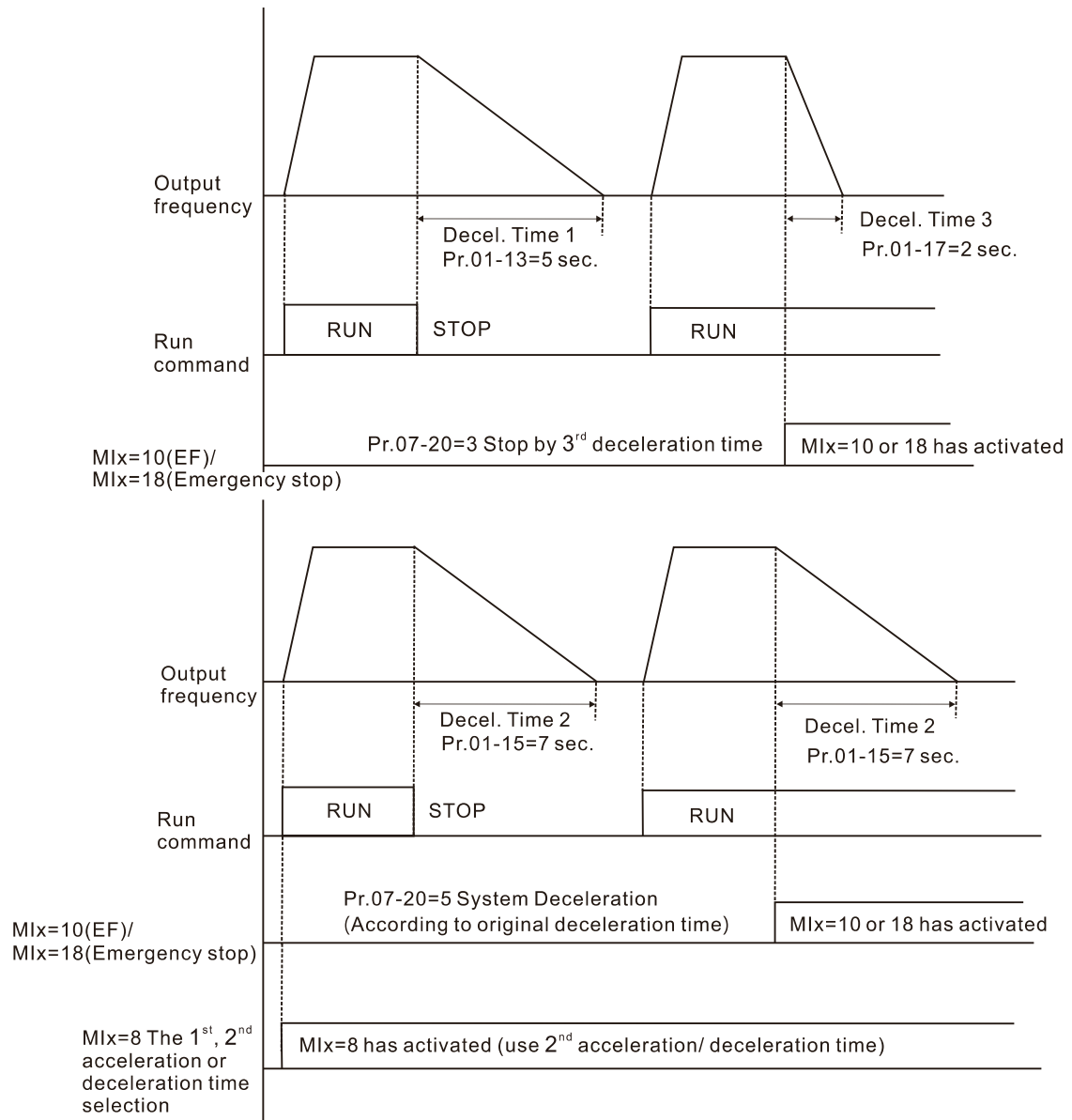

**07-21 Automatic Energy-saving Selection**

Default: 0

Settings 0: Disable  
1: Enable

When energy-saving is enabled, the motor acceleration operates with full voltage. During constant speed operation, it automatically calculates the best voltage value according to the load power. This function is not suitable for fluctuating loads or loads which are nearly full during operation.

When the output frequency is constant (that is, constant operation), the output voltage decreases automatically as the load decreases. Therefore, the drive operates with minimum multiplication of voltage and current (electric power).

**FOCPG IM:**

Steady-speed: Torque current is lower than rated current for 0.35 times and entry into energy saving mode after 5 seconds.

Return: Torque current is higher than 0.5 times of rated current.

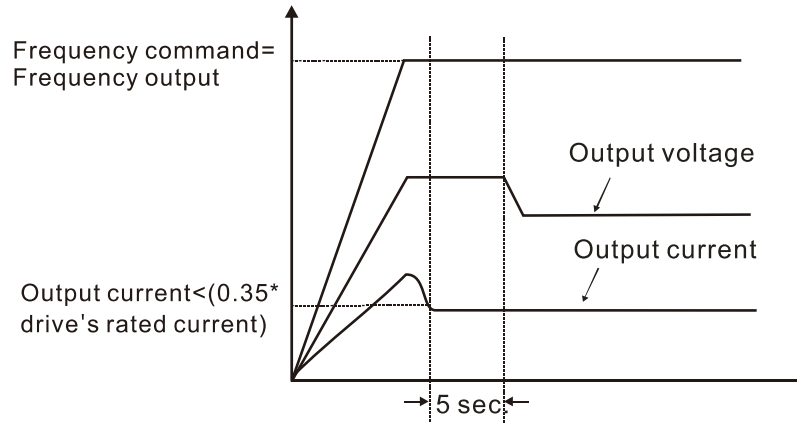

📖 VF, VFPG, SVC mode:

Steady-speed: When output is light load, entry into energy saving mode after 5 seconds.

Return: When the drive is continuously adding loads, or in non-steady speed status.

📖 FOCPM and FOC sensorless control mode, disable.

### 🔪 07-22 Energy-saving Gain

Default: 100

Settings 10–1000%

📖 When Pr. 07-21 is set to 1, use this parameter to adjust the energy-saving gain. The default is 100%. If the result is not satisfactory, adjust it by decreasing the setting value. If the motor oscillates, then increase the setting value.

📖 In certain applications such as high speed spindles, the temperature rise in the motor is a major concern. When the motor is not in working state, reduce the motor current to a lower level. Reduce this parameter setting to meet this requirement.

### 🔪 07-23 Auto Voltage Regulation (AVR) Function

Default: 0

Settings 0: Enable AVR

1: Disable AVR

2: Disable AVR during deceleration

📖 The rated voltage of the motor is usually  $200V_{AC}$ – $240V_{AC}$  ( $380V_{AC}$ – $480V_{AC}$ ), 60Hz/50Hz and the input voltage of the AC motor drive may vary between  $170V_{AC}$ – $264V_{AC}$  ( $323V_{AC}$ – $528V_{AC}$ ), 50Hz/60Hz. Therefore, when the AC motor drive is used without the AVR function, the output voltage is the same as the input voltage. When the motor runs at the voltage exceeding 12%–20% of the rated voltage, it causes higher temperature, damaged insulation, and unstable torque output, which result in losses due to shorter motor lifetime.

📖 The AVR function automatically regulates the output voltage of the AC motor drive to the motor rated voltage. For example, if the V/F curve is set at  $200V_{AC} / 50\text{Hz}$  and the input voltage is at  $200V_{AC}$  to  $264V_{AC}$ , then the drive automatically reduces the output voltage to the motor to a maximum of  $200V_{AC} / 50\text{Hz}$ . If the input voltage is at  $170V_{AC}$  to  $200V_{AC}$ , the output voltage to motor and input power are in direct proportion.

📖 0: When the AVR function is enabled, the drive calculates the output voltage according to the actual DC BUS voltage. The output voltage does NOT change when the DC BUS voltage changes.

- 📖 1: When the AVR function is disabled, the drive calculates the output voltage according to the actual DC BUS voltage. The DC BUS voltage changes the output voltage, and may cause insufficient or over-current or shock.
- 📖 2: the drive disables the AVR function when decelerating to stop, and may accelerate to brake.
- 📖 When the motor ramps to stop, the deceleration time is shorter when setting this parameter to 2 with auto-acceleration and deceleration, and the deceleration is quicker and more stable.
- 📖 When the control mode is set as FOC PG or TQCPG, it is recommended to set this parameter to 0 (enable AVR).

↗ **07-24** Torque Command Filter Time (V/F and SVC Control Mode) Default: 0.500

Settings 0.001–10.000 sec.

- 📖 When the setting is too long, the control is stable but the control response is delayed. When the setting is too short, the response is quick but the control may be unstable. Adjust the setting according to the stability of the control and response times.

↗ **07-25** Slip Compensation Filter Time (V/F and SVC Control Mode) Default: 0.100

Settings 0.001–10.000 sec.

- 📖 Change the compensation response time with Pr.07-24 and Pr.07-25.
- 📖 If you set Pr.07-24 and Pr.07-25 to 10 seconds, the compensation response time is the slowest; however, the system may be unstable if you set the time too short.

↗ **07-26** Torque Compensation Gain (V/F and SVC control mode) Default: 0

Settings IM: 0–10 (when Pr. 05-33 = 0)  
PM: 0–5000 (when Pr. 05-33 = 1 or 2)





- 📖 Only applicable in IMVF and PMSVC control mode.
- 📖 With a large motor load, a part of drive output voltage is absorbed by the stator winding resistor; therefore, the air gap magnetic field is insufficient. This causes insufficient voltage at motor induction and results in excessive output current but insufficient output torque. Auto-torque compensation can automatically adjust the output voltage according to the load and keep the air gap magnetic fields stable to get the optimal operation
- 📖 In the V/F control, the voltage decreases in direct proportion with decreasing frequency. It reduces the torque decrease at low speed due to the AC impedance while the DC resistor is unchanged. The auto-torque compensation function increases the output voltage at low frequency to get a higher starting torque.
- 📖 When the compensation gain is set too large, it may cause motor over-flux and result in a too large output current, overheating the motor or triggering the protection function.
- 📖 This parameter affects the output current when the drive runs. But the effect is smaller at the low-speed area.
- 📖 Set this parameter higher when the no-load current is too large, but the motor may vibrate if the setting is too high. If the motor vibrates when operating, reduce the setting.

### 07-27 Slip Compensation Gain (V/F and SVC control mode)

Default: 0.00

(1.00 in SVC mode)

Settings 0.00–10.00

-  The induction motor needs constant slip to produce magnetic torque. It can be ignored at higher motor speeds, such as rated speed or 2–3% of slip.
-  In operation, the slip and the synchronous frequency are in reverse proportion to produce the same magnetic torque. The slip is larger with the reduction of synchronous frequency. The motor may stop when the synchronous frequency decreases to a specific value. Therefore, the slip seriously affects the motor speed accuracy at low speed.
-  In another situation, when you use an induction motor with the drive, the slip increases when the load increases. It also affects the motor speed accuracy.
-  Use this parameter to set the compensation frequency, and reduce the slip to maintain the synchronous speed when the motor runs at the rated current in order to improve the accuracy of the drive. When the drive output current is higher than Pr.05-05 (No-load Current of Induction Motor 1 (A)), the drive compensates the frequency with this parameter.
-  This parameter is set to 1.00 automatically when Pr.00-11 (Speed Control Method) is changed from V/F mode to vector mode. Apply the slip compensation after load and acceleration. Increase the compensation value from small to large gradually; add the output frequency with motor rated slip \* Pr.07-27 (Slip Compensation Gain) when the motor is at the rated load. If the actual speed ratio is slower than expected, increase the parameter setting value; otherwise, decrease the setting value.

### 07-29 Slip Deviation Level

Default: 0

Settings 0.0–100.0%

0: No detection

### 07-30 Over Slip Deviation Detection Time

Default: 1.0

Settings 0.0–10.0 sec.

### 07-31 Over Slip Deviation Treatment

Default: 0

Settings

- 0: Warn and continue operation
- 1: Warn and ramp to stop
- 2: Warn and coast to stop
- 3: No warning

-  Pr. 07-29 to Pr. 07-31 set the allowable slip level / time and the over-slip action when the drive is running.



↗ **07-32** Motor Shock Compensation Factor

Default: 1000

Settings 0–10000  
0: Disable

📖 If there are current wave motions in the motor in some specific area, setting this parameter can effectively improve this situation. When running with high frequency or PG, set this parameter to 0. When the current wave motion occurs in low frequency and high-power, increase the value for Pr. 07-32.

↗ **07-33** Auto-restart Interval of Fault

Default: 60.0

Settings 0.0–6000.0 sec.

📖 When a reset / restart occurs after a fault, the drive uses Pr. 07-33 as a timer and starts counting the numbers of faults within this time period. Within this period, if the number of faults does not exceed the setting for Pr. 07-11, the counting clears and starts from 0 when the next fault occurs.

↗ **07-38** PMSVC Voltage Feedback Forward Gain

Default: 1.00

Settings 0.50–2.00

📖 Adjusts the PMSVC voltage feedback forward gain, and to meet the demand of rapid feedback application.

📖 Pr. 07-38=1.00 means forward feedback =  $K_e \cdot \text{motor rotor speed}$

📖 Refer to Section 12-2 “PMSVC adjustment” for details.

↗ **07-62** dEb Gain (Kp)

Default: 8000

Settings 0–65535

↗ **07-63** dEb Gain (Ki)

Default: 150

Settings 0–65535

📖 Sets the PI gain of DC BUS voltage controller when the dEb function activates.

📖 If the DCBUS voltage drops too fast, or the speed vibration occurs during deceleration after the dEb function activates, adjust Pr. 07-62 and Pr. 07-63. Increase the Kp setting to accelerate the control response, but the vibration may occurs if the setting is too large. Use Ki parameter to decrease the steady-state error to zero, increase the setting to accelerate the response speed.

# 08 High-function PID Parameters

⚡ This parameter can be set during operation.

## ⚡ 08-00 Terminal Selection of PID Feedback

Default:0

- Settings
- 0: No function
  - 1: Negative PID feedback: by analog input (Pr. 03-00–03-02)
  - 2: Negative PID feedback: by PG card pulse input, without direction (Pr. 10-02)
  - 3: Negative PID feedback: by PG card pulse input, with direction (Pr. 10-02)
  - 4: Positive PID feedback: by analog input (Pr. 03-00–03-02)
  - 5: Positive PID feedback: by PG card pulse input, without direction (Pr. 10-02)
  - 6: Positive PID feedback: by PG card pulse input, with direction (Pr. 10-02)
  - 7: Negative PID feedback: by communication protocol
  - 8: Positive PID feedback: by communication protocol

📖 Pr. 08-00 ≠ 0 enables the PID function.

📖 Negative feedback means:

+target value – feedback. The detection value increases by increasing the output frequency.

📖 Positive feedback means:

-target value + feedback. The detection value decreases by increasing the output frequency.

📖 When Pr. 08-00 ≠ 7 neither ≠ 8, the input value is disabled. The value of the setting does not remain the same after the drive is off.

📖 Related applicable parameters: Pr. 00-20, Pr. 03-00–03-02

When enable the PID function (Pr. 08-00 ≠ 0), if Pr. 00-20 is set to 2 “External analog input”, Pr. 03-00–03-02 need to be set to 4 “PID target value” accordingly.

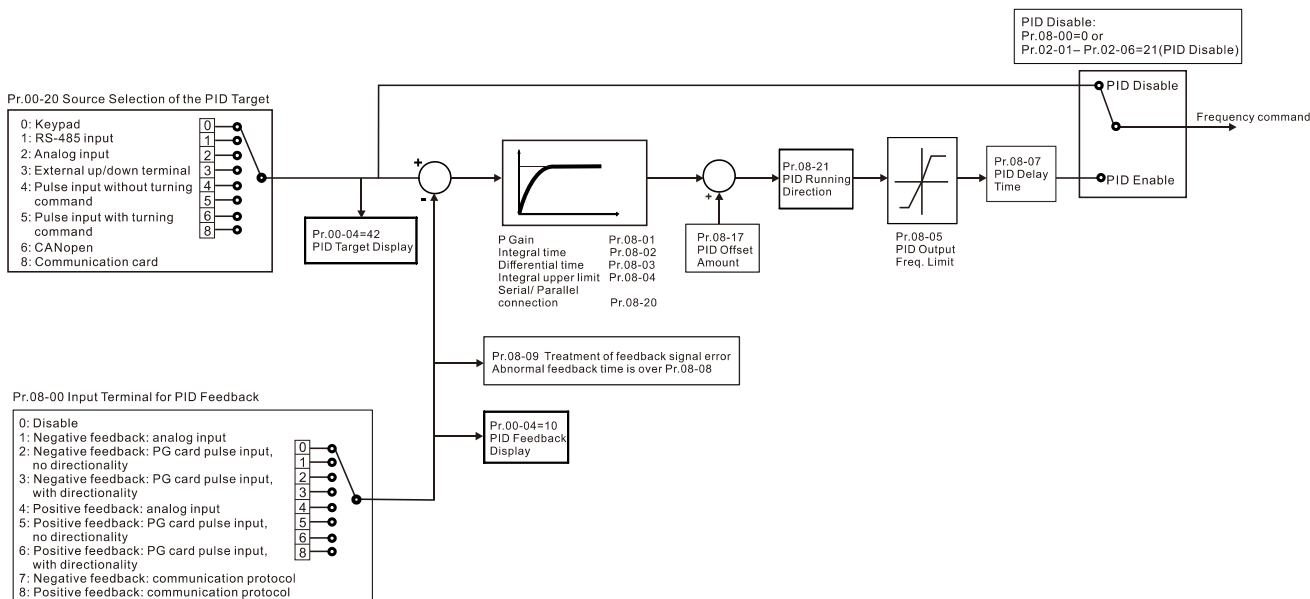

**00-20** Master Frequency Command (AUTO) Source / Source Selection of the PID Target

Default: 0

- Settings
- 0: Digital keypad
  - 1: RS-485 serial communication
  - 2: External analog input (Refer to Pr. 03-00)
  - 3: External UP/DOWN terminal
  - 4: Pulse input without direction command (Pr. 10-16 without direction), use with PG card
  - 5: Pulse input with direction command (Pr. 10-16), use with PG card
  - 6: CANopen communication card
  - 8: Communication card (does not include CANopen card)

↗ **03-00** Analog Input Selection (AVI)

↗ **03-01** Analog Input Selection (ACI)

↗ **03-02** Analog Input Selection (AUI)

Default: 0

Settings

4: PID target value

**Common applications for PID control:**

- 📖 Flow control: Use a flow sensor to feedback the flow data and perform accurate flow control.
- 📖 Pressure control: Use a pressure sensor to feedback the pressure data and perform precise pressure control.
- 📖 Air volume control: Use an air volume sensor to feedback the air volume data to achieve excellent air volume regulation.
- 📖 Temperature control: Use a thermocouple or thermistor to feedback temperature data for comfortable temperature control.
- 📖 Speed control: Use a speed sensor or encoder to feedback motor shaft speed or input another machine speed as a target value for closed loop speed control of the master-slave operation. Pr.10-00 sets the PID set point source (target value).

**PID control loop:**

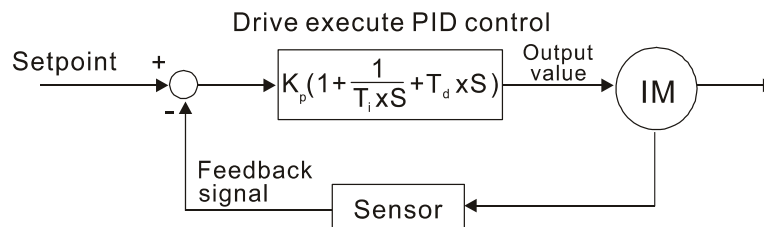

$K_p$ : Proportional gain (P)    $T_i$ : Integral time (I)    $T_d$ : Derivative control (D)   S: Operator

### Concept of PID control

#### Proportional gain (P):

The output is proportional to input. With only proportional gain control, there is always a steady-state error.

Adjustment: Turn off the  $T_i$  and  $T_d$ , or remain  $T_i$  and  $T_d$  in constant value, then adjust the proportional gain (P).

Increase: Faster status feedback, but excessive adjustment will increase the overshoot.

Decrease: Smaller overshoot, but excessive adjustment will slow down the transient response.

#### Integral time (I):

The controller output is proportional to the integral of the controller input. To eliminate the steady-state error, add an “integral part” to the controller. The integral time controls the relation between integral part and the error. The integral part increases over time even if the error is small. It gradually increases the controller output to eliminate the error until it is zero. This stabilizes the system without a steady-state error by using proportional gain control and integral time control.

Adjustment: The integral time (I) accumulates from the time difference, if the vibration cycle is longer than the setting for integral time, the integration enhances. Increase the integral time (I) to reduce the vibration.

Increase: Reduce the overshoot, excessive adjustment causes worse transient response.

Decrease: Faster transient response, but the transient time will be longer, and takes more time to achieve the steady state. Excessive adjustment causes larger overshoot.

#### Differential control (D):

The controller output is proportional to the differential of the controller input. During elimination of the error, oscillation or instability may occur. Use the differential control to suppress these effects by acting before the error. That is, when the error is near zero, the differential control should be zero. Use proportional gain (P) and differential control (D) to improve the system state during PID adjustment.

Adjustment: When the vibration cycle is shorter and continuous, it means that the differential time setting is too large, and causes excessive output. Decrease the setting of D gain to reduce the vibration. If the D gain is set to 0, adjust the PID control again.

### Using PID control in a constant pressure pump feedback application:

Set the application’s constant pressure value (bar) to be the set point of PID control. The pressure sensor sends the actual value as the PID feedback value. After comparing the PID set point and PID feedback, an error displays. The PID controller calculates the output by using proportional gain (P), integral time (I) and differential time (D) to control the pump. It controls the drive to use a different pump speed and achieves constant pressure control by using a 4–20mA signal corresponding to 0–10 bar as feedback to the drive.

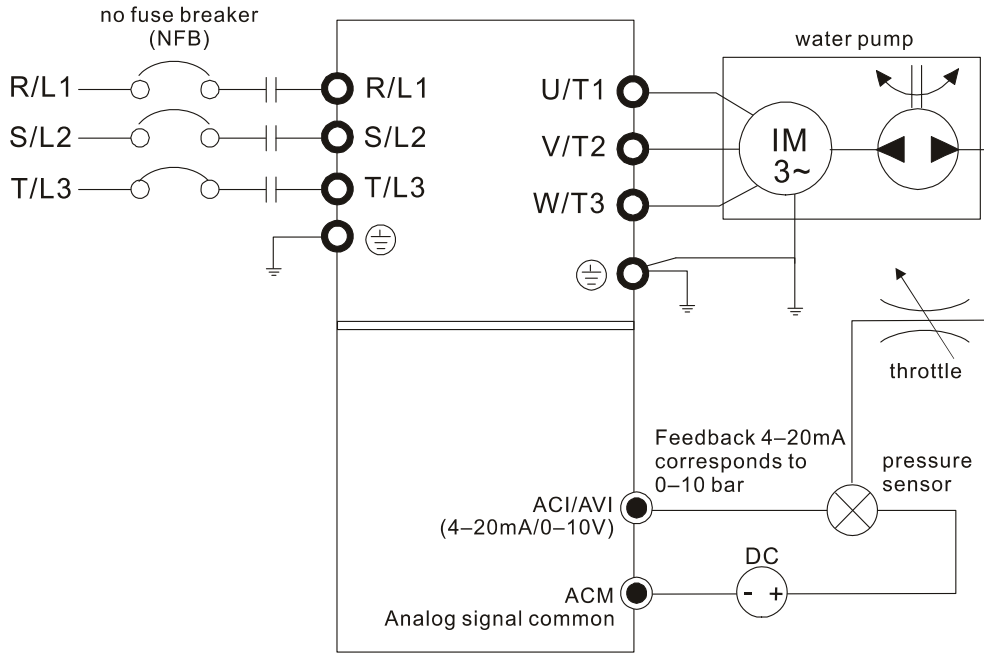

- Pr. 00-04 = 10 (Display PID feedback (b) (%)).
- Pr. 01-12 Acceleration Time is set as according to actual conditions.
- Pr. 01-13 Deceleration Time is set as according to actual conditions.
- Pr. 00-21 = 0 to operate through the digital keypad.
- Pr. 00-20 = 0, the digital keypad controls the set point.
- Pr. 08-00 = 1 (Negative PID feedback from analog input)
- ACI analog input Pr. 03-01 = 5, PID feedback signal.
- Pr. 08-01–08-03 is set according to actual conditions:
  - If there is no vibration in the system, increase Pr. 08-01 (Proportional Gain (P))
  - If there is no vibration in the system, decrease Pr. 08-02 (Integral Time (I))
  - If there is no vibration in the system, increase Pr. 08-03 (Differential Time(D))

📖 Refer to Pr. 08-00 to Pr. 08-21 for PID parameter settings.

🔪 **08-01** Proportional Gain (P) Default: 1.0

Settings 0.0–500.0

- 📖 1.0: Kp gain is 100%; if the setting is 0.5, Kp gain is 50%.
- 📖 Determines the deviation response of Proportional gain (P). Eliminates the system error; usually used to decrease the error and get faster response speed. it also reduces the steady-state error. But if you set the value too high, it may cause system oscillation and instability.
- 📖 If you set the other two gains (I and D) to zero, proportional control is the only effective parameter.

🔪 **08-02** Integral Time (I) Default: 1.00

Settings 0.00–100.00 sec.

0.00: No integral

- 📖 Use the integral controller to eliminate the error during stable system operation. The integral control does not stop working until the error is zero. The integral is affected by the integral time.

The smaller the integral time, the stronger integral action. It is helpful to reduce overshoot and oscillation for a stable system. Accordingly, the speed to lower the steady-state error decreases. The integral control is often used with the other two controls for the PI controller or PID controller.

- 📖 Sets the integral time of the I controller. When the integral time is long, there is a small I controller gain, with slower response and slow external control. When the integral time is short, there is a large I controller gain, with faster response and rapid external control.
- 📖 When the integral time is too short, it may cause system oscillation.
- 📖 Set Integral Time to 0.00 to disable Pr. 08-02.

### ↗ **08-03** Differential Time (D)

Default: 0.00

Settings 0.00–1.00 sec.

- 📖 Use the differential controller to show the system error change, as well as to preview the change in the error. You can use the differential controller to eliminate the error in order to improve the system state. Using a suitable differential time can reduce overshoot and shorten adjustment time; however, the differential operation increases noise interference. Note that a too large differential causes more noise interference. In addition, the differential shows the change and the output is 0 when there is no change. Note that you cannot use the differential control independently. You must use it with the other two controllers for the PD controller or PID controller.
- 📖 Sets the D controller gain to determine the error change response. Using a suitable differential time reduces the P and I controllers overshoot to decrease the oscillation for a stable system. A differential time that is too long may cause system oscillation.
- 📖 The differential controller acts on the change in the error and cannot reduce the interference. Do not use this function when there is significant interference.

### ↗ **08-04** Upper Limit of Integral Control

Default: 100.0

Settings 0.0–100.0%











- 📖 Defines an upper bound for the integral gain (I) and therefore limits the master frequency. The formula is: Integral upper bound = Maximum Operation Frequency (Pr. 01-00) x Pr. 08-04 %.
- 📖 An excessive integral value causes a slow response due to sudden load changes and may cause motor stall or machine damage.

### ↗ **08-05** PID Output Command Limit

Default: 100.0

Settings 0.0–110.0%

- 📖 Defines the percentage of the output frequency limit during the PID control. The formula is Output Frequency Limit = Maximum Operation Frequency (Pr. 01-00) x Pr. 08-05 %.

-  **08-06** PID Feedback Value by Communication Protocol Default: Read only  
 Settings -200.00%–200.00%
- 
-  Use communication to set the PID feedback value when the PID feedback input is set to communication (Pr.08-00 = 7 or 8).
-  **08-07** PID Delay Time Default: 0.0  
 Settings 0.0–35.0 sec.
- 
-  **08-20** PID Mode Selection Default: 0  
 Settings 0: Serial connection  
 1: Parallel connection
- 
-  0: Serial connection, use conventional PID control structure.  
 1: Parallel connection, the proportional gain, integral gain and differential gain are independent.  
 You can customize the P, I and D value to fit your application.
-  Pr. 08-07 determines the primary low pass filter time when in PID control. Setting a large time constant may slow down the drive's response rate.
-  PID control output frequency is filtered with a primary low pass function. This function can filter a mix frequencies. A long primary low pass time means the filter degree is high and a short primary low pass time means the filter degree is low.
-  Inappropriate delay time setting may cause system error.
-  PI Control:  
 Controlled only by the P action, so the deviation cannot be entirely eliminated. In general, to eliminate residual deviations, the P + I controls. When you use the PI control, it eliminates the deviation caused by the targeted value changes and the constant external interferences. However, if the I action is too powerful, it delays the response when there is rapid variation. You can use the P action by itself to control the loading system with the integral components.
-  PD Control:  
 When deviation occurs, the system immediately generates an operation load that is greater than the load generated only by the D action to restrain deviation increment. If the deviation is small, the effectiveness of the P action decreases as well. The control objects include applications with integral component loads, which are controlled by the P action only. Sometimes, if the integral component is functioning, the whole system may vibrate. In this case, use the PD control to reduce the P action's vibration and stabilize the system. In other words, this control is useful with no brake function's loading over the processes.
-  PID Control:  
 Use the I action to eliminate the deviation and the D action to reduce vibration; then combine this with the P action for the PID control. Use the PID method for a control process with no deviations, high accuracies and a stable system.

Serial Connection

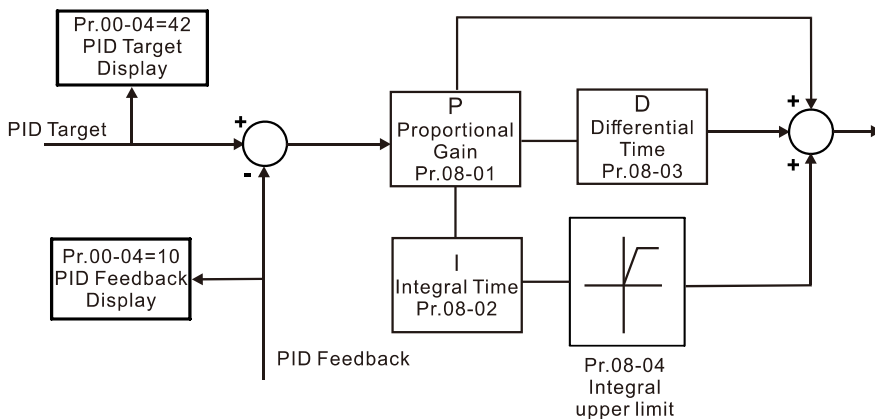

Parallel Connection

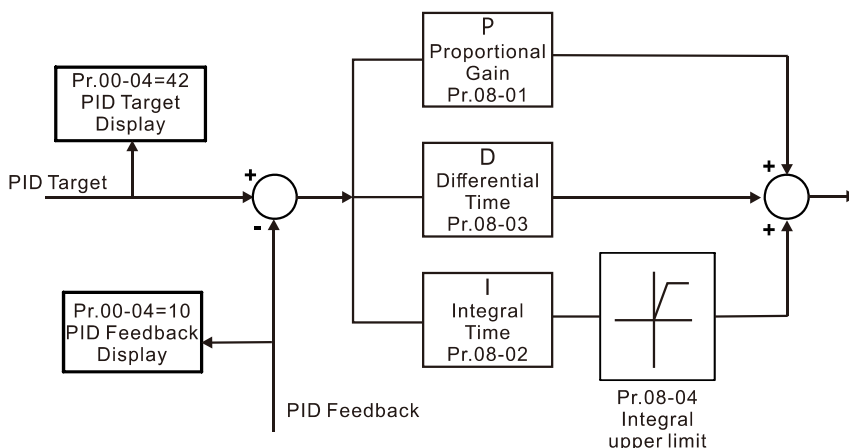

**08-08** Feedback Signal Detection Time Default: 0.0

Settings 0.0–3600.0 sec.

- Pr. 08-08 is valid only for ACI 4–20mA.
- This parameter sets the detection time for abnormal PID signal feedback. Setting the detection time to 0.0 disables the detection function.

**08-09** Feedback Signal Fault Treatment Default: 0

Settings 0: Warn and continue operation  
 1: Warn and ramp to stop  
 2: Warn and coast to stop  
 3: Warn and operate at last frequency

- This parameter is valid only for ACI 4–20mA.
- AC motor drive acts when the analog PID feedback is abnormal.

**08-10** Sleep Reference Default: 0.00

Settings 0.00–599.00 Hz





- Determines the sleep frequency, and if the sleep time and the wake-up frequency are enabled or disabled. Pr. 08-10 = 0: Disabled; Pr. 08-10 ≠ 0: Enabled.



### 08-11 Wake-up Frequency

Default: 0.00

Settings 0.00–599.00 Hz

-  When Pr. 08-18 = 0, the unit for Pr. 08-10 and that for Pr. 08-11 switch to frequency. The settings are become 0–600.00 Hz.
-  When Pr. 08-18=1, the unit for Pr. 08-10 and that for Pr. 08-11 switch to percentage. The settings then are to 0–200.00%.
-  The percentage is based on the current command value, not the maximum value. For example, if the maximum value is 100 kg, and the current value is 30kg, then if Pr. 08-11 = 40%, the value is 12 kg.
-  Pr. 08-10 uses the same logic for calculation.

### 08-12 Sleep Time

Default: 0.0

Settings 0.0–6000.0 sec.

-  When the frequency command is smaller than the sleep frequency and less than the sleep time, the frequency command is equal to the sleep frequency. However, the frequency command remains at 0.00 Hz until the frequency command becomes equal to or larger than the wake-up frequency.

### 08-13 PID Deviation Level



Default: 10.0

Settings 1.0–50.0%

### 08-14 PID Deviation Time

Default: 5.0

Settings 0.1–300.0 sec.

-  When the PID control function is normal, it should calculate the value within a period of time that is close to the target value.
-  Refer to the PID control diagram for details. When executing PID feedback control, if  $|\text{PID reference target value} - \text{detection value}| > \text{Pr. 08-13 PID Deviation Level}$  and exceeds Pr. 08-14 setting, it is judged as a PID control fault, and the multi-function output MOx = 15 (PID feedback error) activates.

### 08-15 PID Feedback Filter Time



Default: 5.0

Settings 0.1–300.0 sec.

### 08-16 PID Compensation Selection

Default: 0

Settings 0: Parameter setting (Pr. 08-17)  
1: Analog input

-  0: The setting for Pr. 08-17 gives the PID compensation value.
-  1: Set the analog input (Pr. 03-00–03-02) to 13, then the PID compensation value of analog input is displayed on Pr. 08-17. At this time, Pr. 08-17 is read only).

### 08-17 PID Compensation

Default: 0.0

Settings -100.0–100.0%

- 📖 The PID compensation value = maximum PID target value × Pr. 08-17. For example, if the maximum operation frequency Pr. 01-00 = 60.00 Hz, Pr. 08-17 = 10.0%, the PID compensation value increases the output frequency 6.00Hz.  $60.00\text{Hz} \times 100.00\% \times 10.0\% = 6.00\text{Hz}$

### 08-18 Sleep Mode Function Setting

Default: 0

Settings 0: Refer to PID output command  
1: Refer to PID feedback signal

- 📖 0: The unit for Pr. 08-10 and that for Pr. 08-11 switch to frequency. The settings then are between 0–599.00 Hz.
- 📖 1: The unit for Pr. 08-10 and that for Pr. 08-11 switch to percentage. The settings then are between 0–200.00%.

### 08-19 Wake-up Integral Limit

Default: 50.0

Settings 0.0–200.0%

- 📖 The wake-up integral limit for the drive prevents suddenly running at high speed when the drive wakes up. The wake-up integral frequency limit = (Pr. 01-00 × Pr. 08-19%)
- 📖 Reduces the reaction time from sleep to wake-up.

### 08-21 Enable PID to Change the Operation Direction

Default: 0

Settings 0: Operation direction cannot be changed  
1: Operation direction can be changed

### 08-22 Wake-up Delay Time

Default: 0.00

Settings 0.00–600.00 sec.

- 📖 Refer to Pr. 08-18 for more information.

### 08-23 PID Control Flag

Default: 0000h

Settings bit0 = 1, PID running in reverse follows the setting for Pr. 00-23  
bit0 = 0, PID running in reverse follows PID's calculated value  
bit1 = 1, second decimal place of PID Kp  
bit1 = 0, first decimal place of PID Kp

- 📖 bit0 = 1: Valid when enables PID running in reverse (Pr. 08-21 = 1).
- 📖 bit0 = 0, if the PID calculated value is positive, the direction is forward. If the PID calculated value is negative, the direction is reverse.

There are three scenarios for sleep and wake-up frequency. Refer to following explanations:

1) Frequency Command (PID is not in use, Pr. 08-00 = 0, only works in VF mode)

When the output frequency  $\leq$  the sleep frequency, and the drive reaches the preset sleep time, then the the drive is in sleep mode.

When the frequency command reaches the wake-up frequency, the drive starts to count the wake-up delay time. When the drive reaches the wake-up delay time, the drive begins acceleration time to reach the frequency command value.

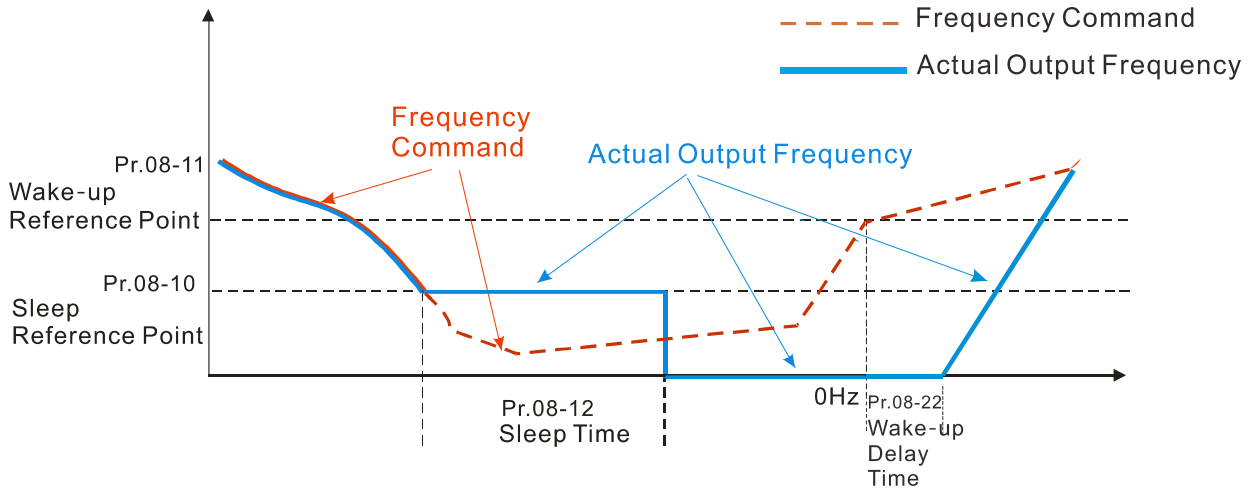

2) Frequency Command Calculation of the Internal PID (Use PID, Pr. 08-00≠0 and Pr. 08-18=0)

When the PID calculation reaches the sleep frequency, the drive starts to count the sleep time and the output frequency starts to decrease. If the drive exceeds the preset sleep time, it goes directly to sleep mode (0Hz). If the drive does not reach the sleep time, it remains at the lower limit (if there is a preset of lower limit.), or it remains at the lowest output frequency set at Pr. 01-07 and waits to reach the sleep time before it goes into sleep mode (0Hz).

When the calculated frequency command reaches the wake-up frequency, the drive starts to count the wake-up delay time. Once it reaches the wake-up delay time, the drive starts the acceleration time to reach the PID frequency command value.

Internal PID Calculation Frequency Command

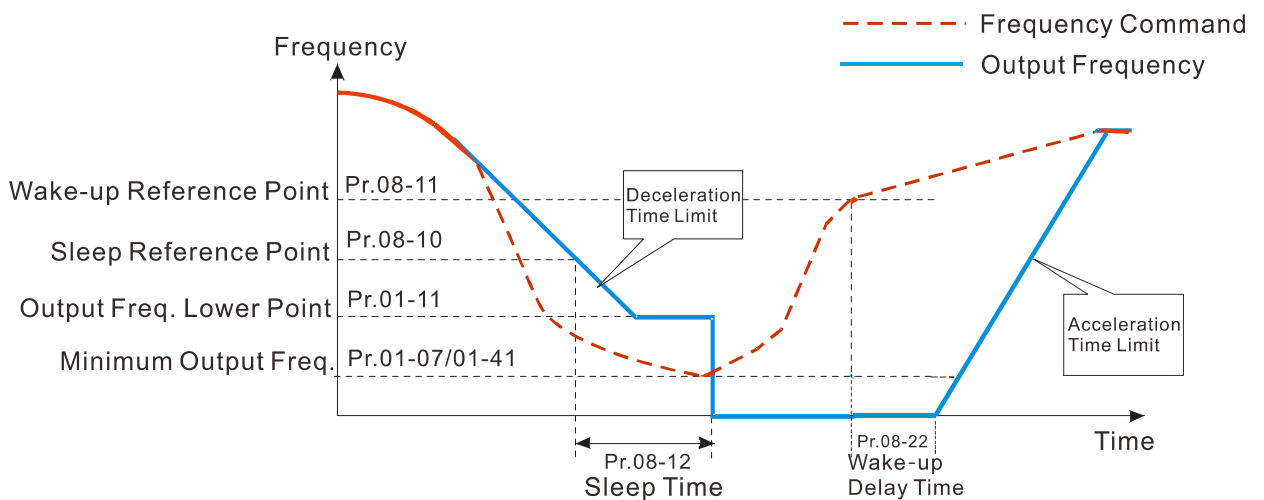

3) PID Feedback Rate Percentage (Use PID, Pr. 08-00 ≠ 0 and Pr. 08-18 = 1)

When the PID feedback rate reaches the sleep level percentage, the drive starts to count the sleep time. The output frequency also decreases. If the drive exceeds the preset sleep time, it goes to sleep mode (0 Hz). If the drive does not reach the sleep time, it remains at the lower limit (if there is a preset of lower limit.), or it remains at the lowest output frequency set for Pr.01-07 and waits to reach the sleep time before going into sleep mode (0 Hz).

When the PID feedback value reaches the wake-up percentage, the drive starts to count the wake-up delay time. Once it reaches the wake-up delay time, the drive starts the acceleration time to reach the PID frequency command value.

Example 01: PID negative feedback

- Pr. 08-10 must > Pr. 08-11
- 30kg is the reference
- Set the parameter:  
 Pr. 03-00 = 5 (AVI is PID feedback)  
 Pr. 08-00 = 1 (PID negative feedback: AVI simulation input function select)  
 Pr. 08-10 = 40% (Sleep reference: 12kg = 40%\*30kg)  
 Pr. 08-11 = 20% (Wake-up reference: 6kg = 20%\*30kg)  
 Case 01: If feedback >12kg, frequency decreases.  
 Case 02: If feedback <6kg, frequency increases.

Area	PID Physical quantity
Sleep area	>12kg, the drive goes into sleep or goes into sleep
Excessive area	between 6kg and 12kg, the drive remains in current state
Wake-up area	<6kg, the drive wakes-up motor wakes-up

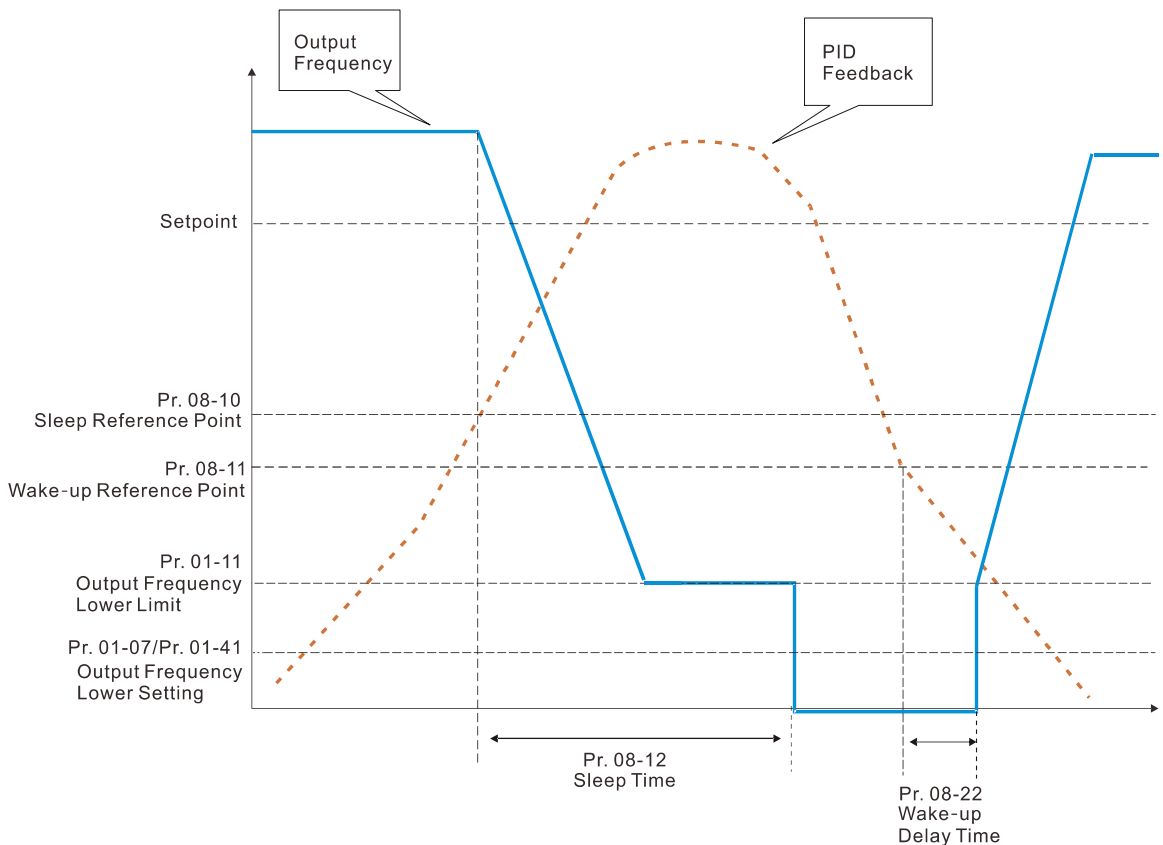

Example 02: PID positive feedback

- Pr. 08-10 must < Pr. 08-11
- 30kg is the reference
- Set the parameter:  
 Pr. 03-00 = 5 (AVI is PID feedback)  
 Pr. 08-00 = 4 (PID positive feedback: AVI simulation input function select)  
 Pr. 08-10 = 110% (Sleep reference:  $33\text{kg} = 110\% \cdot 30\text{kg}$ )  
 Pr. 08-11 = 120% (Wake-up reference:  $36\text{kg} = 120\% \cdot 30\text{kg}$ )

Case 01: If feedback < 33kg, frequency decreases.

Case 02: If feedback > 36kg, frequency increases.

Area	PID Physical quantity
Sleep area	>36kg, the drive goes into sleepmotor goes into sleep
Excessive area	between 33kg and 36kg, the drive remains in the current state
Wake-up area	<33kg, the drive wakes-up

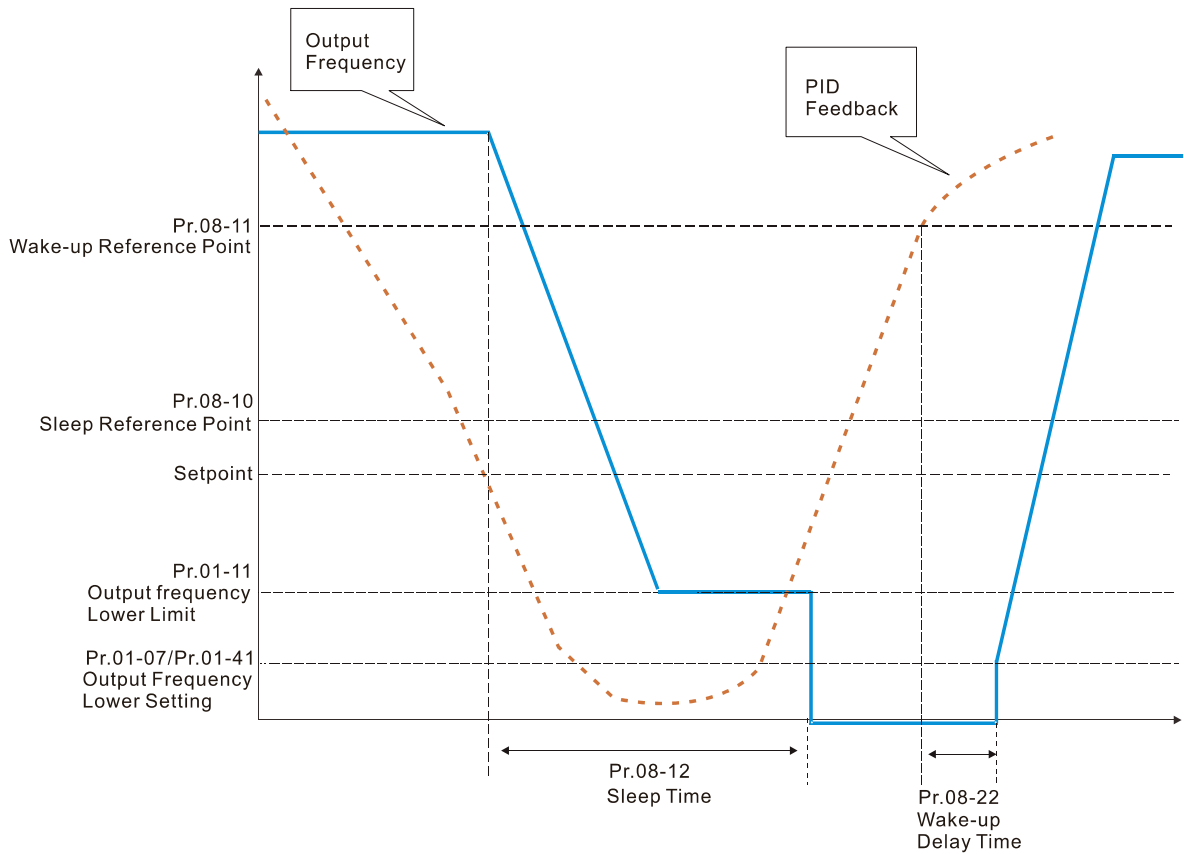

## 09 Communication Parameters

✎ The parameter can be set during the operation.

When using communication devices, connects AC drive with PC by using Delta IFD6530 or IFD6500.

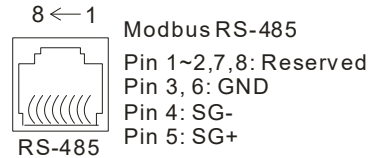

### ✎ 09-00 Communication Address

Default: 1

Settings 1–254

📖 If RS-485 serial communication controls the AC motor drive, you must set the communication address for this drive in this parameter. Each AC motor drive's communication address must be different.

### ✎ 09-01 COM1 Transmission Speed

Default: 9.6

Settings 4.8–115.2Kbps

📖 Sets the transmission speed of the computer and the drive.

📖 Options are 4.8Kbps, 9.6Kbps, 19.2Kbps, 38.4Kbps, 57.6Kbps, and 115.2Kbps; otherwise, the transmission speed is set to the default 9.5Kbps.

### ✎ 09-02 COM1 Transmission Fault Treatment

Default: 3

Settings 0: Warn and continue operation

1: Warn and ramp to stop

2: Warn and coast to stop

3: No warning and continue operation

📖 Sets the response for Modbus communication errors in with the host. Set the detection time in Pr. 09-03.

### ✎ 09-03 COM1 Time-out Detection

Default: 0.0

Settings 0.0–100.0 sec.

📖 Sets the communication transmission time-out.

### ✎ 09-04 COM1 Communication Protocol

Default: 1

Settings 1 : 7, N, 2 (ASCII)

2 : 7, E, 1 (ASCII)

3 : 7, O, 1 (ASCII)

4 : 7, E, 2 (ASCII)

5 : 7, O, 2 (ASCII)

6 : 8, N, 1 (ASCII)

7 : 8, N, 2 (ASCII)

- 8 : 8, E, 1 (ASCII)
- 9 : 8, O, 1 (ASCII)
- 10 : 8, E, 2 (ASCII)
- 11 : 8, O, 2 (ASCII)
- 12 : 8, N, 1 (RTU)
- 13 : 8, N, 2 (RTU)
- 14 : 8, E, 1 (RTU)
- 15 : 8, O, 1 (RTU)
- 16 : 8, E, 2 (RTU)
- 17 : 8, O, 2 (RTU)

 Control by PC (Computer Link)

When using the RS-485 serial communication interface, you must specify each drive's communication address in Pr. 09-00. The computer then implements control using the drives' individual addresses.

 MODBUS ASCII (American Standard Code for Information Interchange): Each byte of data is the combination of two ASCII characters. For example, one byte of data: 64 Hex, shown as '64' in ASCII, consists of '6' (36Hex) and '4' (34Hex).

**1. Code Description**

The communication protocol is in hexadecimal, ASCII: "0"... "9", "A"... "F", every hexadecimal value represents an ASCII code. The following table shows some examples.

Character	'0'	'1'	'2'	'3'	'4'	'5'	'6'	'7'
ASCII code	30H	31H	32H	33H	34H	35H	36H	37H

Character	'8'	'9'	'A'	'B'	'C'	'D'	'E'	'F'
ASCII code	38H	39H	41H	42H	43H	44H	45H	46H

**2. Data Format**

10-bit character frame (For ASCII):

(7, N, 2)

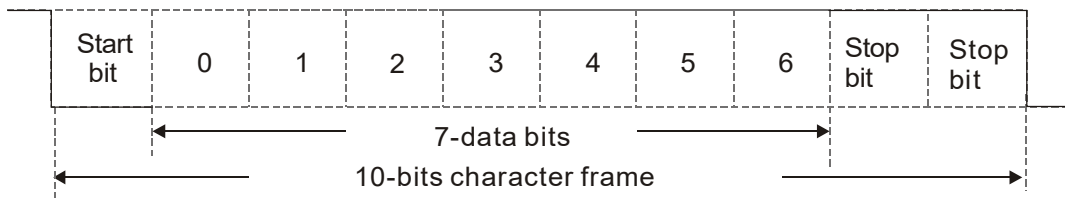

(7, E, 1)

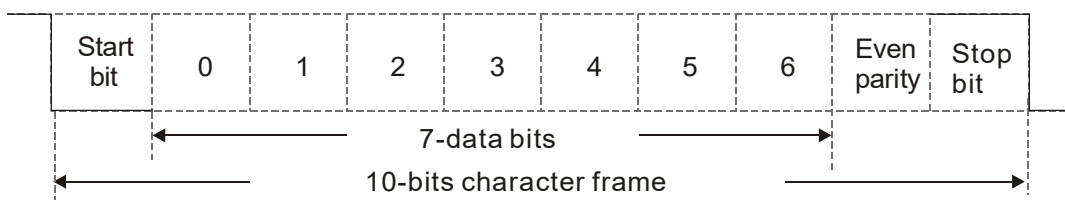

(7, O, 1)

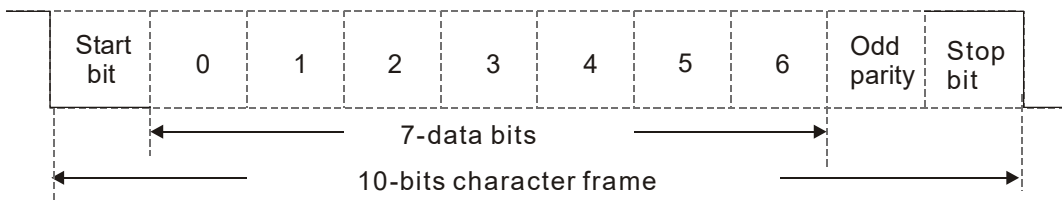

11-bit character frame (For RTU):

(8, N, 2)

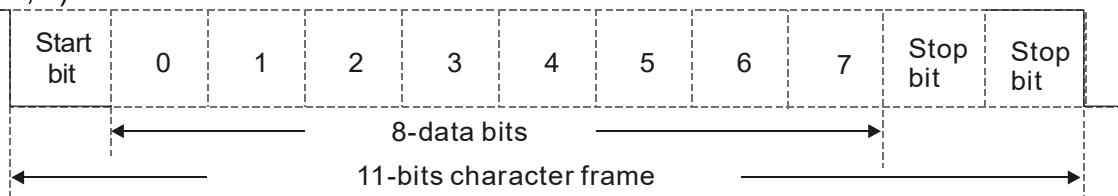

(8, E, 1)

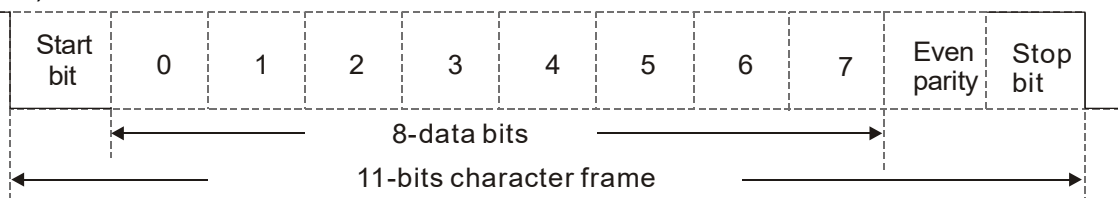

(8, O, 1)

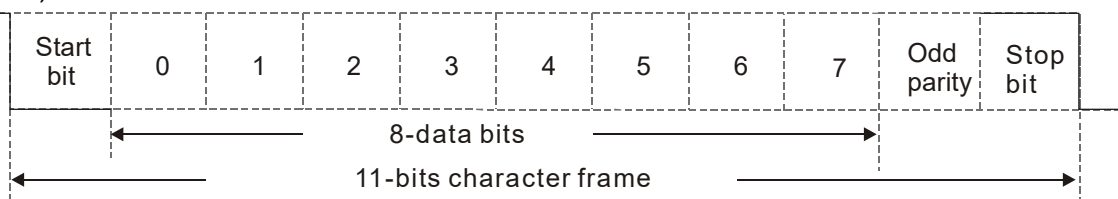

### 3. Communication Protocol

Communication Data Frame:

ASCII mode:

STX	Start character = ':' (3AH)
Address High	Communication address: one 8-bit address consists of 2 ASCII codes
Address Low	
Function High	Command code: one 8-bit command consists of 2 ASCII codes
Function Low	
DATA (n-1)	Contents of data: n x 8-bit data consists of 2n ASCII codes n ≤ 16, maximum of 32 ASCII codes (20 sets of data)
.....	
DATA 0	
LRC Check High	LRC checksum: one 8-bit checksum consists of 2 ASCII codes
LRC Check Low	
END High	End characters: END1= CR (0DH), END0= LF(0AH)
END Low	



**RTU mode:**

START	Defined by a silent interval of more than 10 ms
Address	Communication address: 8-bit address
Function	Command code: 8-bit command
DATA (n-1)	Contents of data: N × 8-bit data, n ≤ 16
.....	
DATA 0	
CRC Check Low	CRC checksum: one 16-bit checksum consists of 2 8-bit characters
CRC Check High	
END	Defined by a silent interval of more than 10 ms

Communication Address (Address)

- 00H: broadcast to all AC motor drives
- 01H: AC motor drive of address 01
- 0FH: AC motor drive of address 15
- 10H: AC motor drive of address 16
- :
- FEH: AC motor drive of address 254

Function (Function code) and DATA (data characters)

- 03H: read data from a register
- 06H: write to a single register

Example: Reading two continuous data from register address 2102H, AMD address is 01H.

**ASCII mode:**

Command Message:		Response Message	
STX	‘.’	STX	‘.’
Address	‘0’	Address	‘0’
	‘1’		‘1’
Function	‘0’	Function	‘0’
	‘3’		‘3’
Starting register	‘2’	Number of register (count by byte)	‘0’
	‘1’		‘4’
	‘0’	Content of starting register 2102H	‘1’
	‘2’		‘7’
Number of register (count by word)	‘0’	Content of register 2103H	‘7’
	‘0’		‘0’
	‘0’		‘0’
	‘2’		‘0’
LRC Check	‘D’	LRC Check	‘0’
	‘7’		‘7’
END	CR	END	‘1’
	LF		CR
			LF

**RTU mode:**

Command Message:		Response Message	
Address	01H	Address	01H
Function	03H	Function	03H
Starting data register	21H	Number of register (count by byte)	04H
	02H		Content of register address 2102H
Number of register (count by word)	00H		17H
	02H		70H
CRC Check Low	6FH	Content of register address 2103H	00H
CRC Check High	F7H		00H
		CRC Check Low	FEH
		CRC Check High	5CH

06H: single write, write single data to a register.

Example: Writing data 6000 (1770H) to register 0100H. AMD address is 01H.

**ASCII mode:**

Command Message:		Response Message	
STX	‘.’	STX	‘.’
Address	‘0’	Address	‘0’
	‘1’		‘1’
Function	‘0’	Function	‘0’
	‘6’		‘6’
Target register	‘0’	Target register	‘0’
	‘1’		‘1’
	‘0’		‘0’
	‘0’		‘0’
Register content	‘1’	Register content	‘1’
	‘7’		‘7’
	‘7’		‘7’
	‘0’		‘0’
LRC Check	‘7’	LRC Check	‘7’
	‘1’		‘1’
END	CR	END	CR
	LF		LF

**RTU mode:**

Command Message:		Response Message	
Address	01H	Address	01H
Function	06H	Function	06H
Target register	01H	Target register	01H
	00H		00H
Register content	17H	Register content	17H
	70H		70H
CRC Check Low	86H	CRC Check Low	86H
CRC Check High	22H	CRC Check High	22H

10H: write multiple registers (write multiple data to registers). The system can write up to 20 sets of data simultaneously.

Example: Set the multi-step speed of an AC motor drive (address is 01H),

Pr. 04-00 = 50.00 (1388H), Pr. 04-01 = 40.00 (0FA0H).

**ASCII Mode**

Command Message:		Response Message	
STX	'.'	STX	'.'
ADR 1	'0'	ADR 1	'0'
ADR 0	'1'	ADR 0	'1'
CMD 1	'1'	CMD 1	'1'
CMD 0	'0'	CMD 0	'0'
Target register	'0'	Target register	'0'
	'5'		'5'
	'0'		'0'
	'0'		'0'
Number of register (count by word)	'0'	Number of register (count by word)	'0'
	'0'		'0'
	'2'		'2'
Number of register (count by byte)	'0'	LRC Check	'E'
	'4'		'8'
The first data content	'1'	END	CR
	'3'		LF
	'8'		
	'8'		
The second data content	'0'		
	'F'		
	'A'		
LRC Check	'0'		
	'9'		
END	'A'		
	CR		
	LF		

**RTU mode:**

Command Message:		Response Message:	
ADR	01H	ADR	01H
CMD	10H	CMD	10H
Target register	05H	Target register	05H
	00H		00H
Number of register (Count by word)	00H	Number of register (Count by word)	00H
	02H		02H
Quantity of data (byte)	04	CRC Check Low	41H
The first data content	13H	CRC Check High	04H
	88H		
The second data content	0FH		
	A0H		
CRC Check Low	'9'		
CRC Check High	'A'		

Check sum

ASCII mode:

LRC (Longitudinal Redundancy Check) is calculated by summing up the values of the bytes from ADR1 to last data character then calculating the hexadecimal representation of the 2's-complement negation of the sum.

Example:

01H + 03H + 21H + 02H + 00H + 02H = 29H, the 2's-complement negation of 29H is D7H.

RTU mode:

CRC (Cyclical Redundancy Check) is calculated by the following steps:

**Step 1:** Load a 16-bit register (called CRC register) with FFFFh.

**Step 2:** Exclusive OR the first 8-bit byte of the command message with the low order byte of the 16-bit CRC register, putting the result in the CRC register.

**Step 3:** Examine the LSB of CRC register.

**Step 4:** If the LSB of CRC register is 0, shift the CRC register one bit to the right, fill MSB with zero, then repeat step 3. If the LSB of CRC register is 1, shift the CRC register one bit to the right, fill MSB with zero, Exclusive OR the CRC register with the polynomial value A001H, then repeat step 3.

**Step 5:** Repeat step 3 and 4 until you perform eight shifts. This processes a complete 8-bit byte.

**Step 6:** Repeat step 2 through 5 for the next 8-bit byte of the command message. Continue doing this until all bytes are processed. The final contents of the CRC register are the CRC value. When transmitting the CRC value in the message, the upper and lower bytes of the CRC value must be swapped, that is, the lower order byte is transmitted first.

The following is an example of CRC generation using C language. The function takes two arguments:

Unsigned char\* data ← a pointer to the message buffer

Unsigned char length ← the quantity of bytes in the message buffer

The function returns the CRC value as a type of unsigned integer.

Unsigned int crc\_chk(unsigned char\* data, unsigned char length)

```
{
    int j;
    unsigned int reg_crc=0xffff;
    while(length--){
        reg_crc ^= *data++;
        for(j=0;j<8;j++){
            if(reg_crc & 0x01){ /* LSB(b0)=1 */
                reg_crc=(reg_crc>>1) ^ 0xa001;
            }else{
                reg_crc=reg_crc >>1;
            }
        }
    }
    return reg_crc;          // return register CRC
}
```

#### 4. Address list

AC motor drive parameters

Modbus address	Function
GGnnH	GG is the parameter group, nn is the parameter number; for example, the address of Pr. 04-10 is 040AH.

Control command (20xx)

Modbus address	R/W	Function	
2000H	RW	bit1-0	00B: No function
			01B: Stop
			10B: Run
			11B: JOG + RUN
		bit3-2	Reserved
		bit5-4	00B: No function
			01B: FWD
			10B: REV
			11B: Change direction
		bit7-6	00B: 1 <sup>st</sup> acceleration / deceleration
			01B: 2 <sup>nd</sup> acceleration / deceleration
			10B: 3 <sup>rd</sup> acceleration / deceleration
			11B: 4 <sup>th</sup> acceleration / deceleration
		bit11-8	000B: Master speed
0001B: 1 <sup>st</sup> Step speed frequency			
0010B: 2 <sup>nd</sup> Step speed frequency			
0011B: 3 <sup>rd</sup> Step speed frequency			
0100B: 4 <sup>th</sup> Step speed frequency			
0101B: 5 <sup>th</sup> Step speed frequency			
0110B: 6 <sup>th</sup> Step speed frequency			
0111B: 7 <sup>th</sup> Step speed frequency			
1000B: 8 <sup>th</sup> Step speed frequency			
1001B: 9 <sup>th</sup> Step speed frequency			
1010B: 10 <sup>th</sup> Step speed frequency			
1011B: 11 <sup>th</sup> Step speed frequency			
1100B: 12 <sup>th</sup> Step speed frequency			
1101B: 13 <sup>th</sup> Step speed frequency			
1110B: 14 <sup>th</sup> Step speed frequency			
1111B: 15 <sup>th</sup> Step speed frequency			
bit12	1: Enable bit06-11 function		
bit15	Reserved		
2001H	RW	Frequency command (XXX.XX Hz)	
2002H	RW	bit0	1: E.F. ON
		bit1	1: Reset
		bit2	1: Base block (B.B) ON
		bit15-3	Reserved

Status monitor read only (21xx)

Modbus address	R/W	Function
2100H	R	High byte: Warn Code Low Byte: Error Code

Modbus address	R/W	Function
2101H	R	bit1–0 AC motor drive operation status 00B: Drive stops 01B: Drive decelerating 10B: Drive standby 11B: Drive operating
		bit2 1 : JOG Command
		bit4–3 Operation Direction 00B: FWD run 01B: From REV run to FWD run 10B: From FWD run to REV run 11B: REV run
		bit8 1: Master frequency controlled by communication interface
		bit9 1: Master frequency controlled by analog/external signal
		bit10 1: Operation command controlled by communication interface
		bit11 1: Parameter locked
		bit12 1: Enable to copy parameters from keypad
bit15–13 Reserved		
2102H	R	Frequency command (XXX.XX Hz)
2103H	R	Output frequency (XXX.XX Hz)
2104H	R	Output current (XX.XX A). When current is higher than 655.35, it shifts the decimal as (XXX.X A). The decimal can refer to High byte of 211F.
2105H	R	DC BUS Voltage (XXX.X V)
2106H	R	Output voltage (XXX.X V)
2107H	R	Current step number of multi-step speed operation
2108H	R	Reserved
2109H	R	Counter value
210AH	R	Power factor angle (XXX.X)
210BH	R	Output torque (XXX.X %)
210CH	R	Actual motor speed (XXXXXX rpm)
210DH	R	Number of PG feedback pulses (0–65535)
210EH	R	Number of PG2 pulse commands (0–65535)
210FH	R	Power output (X.XXX kW)
2116H	R	Multi-function display (Pr. 00-04)
211BH	R	Maximum Operation Frequency (Pr. 01-00) or Maximum User-defined Value (Pr. 00-26) When Pr. 00-26 is 0, this value is equal to Pr. 01-00 setting When Pr. 00-26 is not 0, and the command source is keypad, this value = Pr. 00-24 * Pr. 00-26 / Pr. 01-00 When Pr. 00-26 is not 0, and the command source is 485, this value = Pr. 09-10 * Pr. 00-26 / Pr. 01-00
211FH	R	High byte: decimal of current value (display)

## Status monitor read only (22xx)

Modbus address	RW	Function
2200H	R	Display output current (A). When current is higher than 655.35, it shifts the decimal as (XXX.X A). The decimal can refer to High byte of 211F.
2201H	R	Display counter value (c)
2202H	R	Actual output frequency (XXXXXX Hz)
2203H	R	DC BUS voltage (XXX.X V)
2204H	R	Output voltage (XXX.X V)

Modbus address	RW	Function
2205H	R	Power angle (XXX.X)
2206H	R	Display actual motor speed kW of U, V, W (XXXXXX kW)
2207H	R	Display motor speed in rpm estimated by the drive or encoder feedback (XXXXXX rpm)
2208H	R	Display positive/negative output torque in %, estimated by the drive (t0.0: positive torque, -0.0: negative torque) (XXX.X %)
2209H	R	Display PG feedback (see NOTE 1 in Pr. 00-04)
220AH	R	PID feedback value after enabling PID function (XXX.XX %)
220BH	R	Display signal of AVI analog input terminal, 0–10V corresponds to 0.00–100.00% (1.) (see NOTE 2 in Pr. 00-04)
220CH	R	Display signal of ACI analog input terminal, 4–20mA / 0–10V corresponds to 0.00–100.00% (2.) (see NOTE 2 in Pr. 00-04)
220DH	R	Display signal of AUI analog input terminal, -10V–10V corresponds to -100.00–100% (3.) (see NOTE 2 in Pr. 00-04)
220EH	R	IGBT temperature of drive power module (XXX.X °C)
220FH	R	The temperature of capacitance (XXX.X °C)
2210H	R	The status of digital input (ON/OFF), refer to Pr. 02-12 (see NOTE 3 in Pr. 00-04)
2211H	R	The status of digital output (ON/OFF), refer to Pr. 02-18 (see NOTE 4 in Pr. 00-04)
2212H	R	The multi-step speed that is executing (S)
2213H	R	The corresponding CPU pin status of digital input (d.) (see NOTE 3 in Pr. 00-04)
2214H	R	The corresponding CPU pin status of digital output (O.) (see NOTE 4 in Pr. 00-04)
2215H	R	Number of actual motor revolution (PG1 of PG card) (P.) it starts from 9 when the actual operation direction is changed or the keypad displays at stop is 0. The maximum is 65535
2216H	R	Pulse input frequency (PG2 of PG card) (XXX.XX Hz)
2217H	R	Pulse input position (PG card PG2), the maximum setting is 65535.
2218H	R	Position command tracing error
2219H	R	Display times of counter overload (XXX.XX %)
221AH	R	GFF (XXX.XX %)
221BH	R	DCBUS voltage ripples (XXX.X V)
221CH	R	PLC register D1043 data (C)
221DH	R	Number of poles of a permanent magnet motor
221EH	R	User page displays the value in physical measure
221FH	R	Output Value of Pr. 00-05 (XXX.XX Hz)
2220H	R	Number of motor turns when drive operates (saves when drive stops, and resets to zero when operating)
2221H	R	Operating position of the motor (saves when drive stops, and resets to zero when operating)
2222H	R	Fan speed of the drive (XXX %)
2223H	R	Control mode of the drive 0: speed mode 1: torque mode
2224H	R	Carrier frequency of the drive (XX kHz)
2225H	R	Reserve
2226H	R	Drive status 00b: No direction bit1–0 01b: Forward 10b: Reverse bit3–2 01b: Drive ready 10b: Error bit4 0b: Motor drive did not output 1b: Motor drive did output

Modbus address	RW	Function
		bit5 0b: No alarm 1b: Alarm
2227H	R	Drive's estimated output torque (positive or negative direction) (XXXX Nt-m)
2228H	R	Torque command (XXX.X %)
2229H	R	kWh display (XXXX.X)
222AH	R	PG2 pulse input in Low Word
222BH	R	PG2 pulse input in High Word
222CH	R	Motor actual position in Low Word
222DH	R	Motor actual position in High Word
222EH	R	PID reference (XXX.XX %)
222FH	R	PID offset (XXX.XX %)
2230H	R	PID output frequency (XXX.XX Hz)
2231H	R	Hardware ID

## Remote IO (26xx)

Modbus address	RW	Function
2601H	R	Each bit corresponds to different terminal input contact
2602H	R	Each bit corresponds to different terminal input contact
2603H– 2640H	R	Reserved
2641H	RW	Each bit corresponds to different terminal output contact
2642H– 2660H	R	Reserved
2661H	R	AVI proportional value
2662H	R	ACI proportional value
2663H	R	AUI proportional value
2664H– 266AH	R	Reserved
266BH	R	Expansion card AI10, 0.0–100.0 % (EMC-A22A)
266CH	R	Expansion card AI11, 0.0–100.0 % (EMC-A22A)
266DH– 26A0H	R	Reserved
26A1H	RW	AFM1 output proportional value
26A2H	RW	AFM2 output proportional value
26A3H– 26AAH	R	Reserved
26ABH	RW	Expansion card AO10, 0.0–100.0 % (EMC-A22A)
26ACH	RW	Expansion card AO11, 0.0–100.0 % (EMC-A22A)

**5. Exception response:**

When the drive is using the communication connection, if an error occurs, the drive responds to the error code and sets the highest bit (bit 7) of code to 1 (function code AND 80H) then responds to the control system to signal that an error occurred.

If the keypad displays “CE-XX” as a warning message, “XX” is the error code at that time. Refer to the table of error codes for communication error for reference.



Example:

ASCII mode:		RTU mode:	
STX	“:”	Address	01H
Address	‘0’	Function	86H
	‘1’	Exception code	02H
Function	‘8’	CRC Check Low	C3H
	‘6’	CRC Check High	A1H
Exception code	‘0’		
	‘2’		
LRC Check	‘7’		
	‘7’		
END	CR		
	LF		

The explanation of exception codes:

Error code	Explanation
1	Function code is not supported or unrecognized.
2	Address is not supported or unrecognized.
3	Data is not correct or unrecognized.
4	Fail to execute this function code

↘ **09-09** Communication Response Delay Time Default: 2.0

Settings 0.0–200.0ms

📖 Sets the response delay time after the AC motor drive receives a communication command as shown in the following.

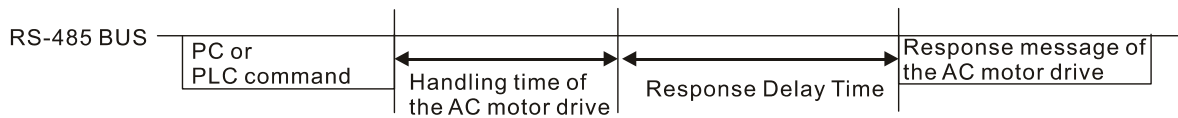

↘ **09-10** Communication Main Frequency Default: 60.00

Settings 0.00–599.00Hz

📖 When you set Pr. 00-20 to 1 (RS-485 serial communication), the AC motor drive saves the last frequency command into Pr. 09-10 when there is abnormal power off or momentary power loss. After the drive reboots when power is restored, it checks the frequency in Pr. 09-10 if no new frequency command is input. When a frequency command of RS-485 changes (the frequency command source must be set as Modbus), this parameter also changes.

- ↘ **09-11** Block Transfer 1
- ↘ **09-12** Block Transfer 2
- ↘ **09-13** Block Transfer 3
- ↘ **09-14** Block Transfer 4
- ↘ **09-15** Block Transfer 5
- ↘ **09-16** Block Transfer 6
- ↘ **09-17** Block Transfer 7
- ↘ **09-18** Block Transfer 8
- ↘ **09-19** Block Transfer 9

↗	<b>09-20</b>	Block Transfer 10
↗	<b>09-21</b>	Block Transfer 11
↗	<b>09-22</b>	Block Transfer 12
↗	<b>09-23</b>	Block Transfer 13
↗	<b>09-24</b>	Block Transfer 14
↗	<b>09-25</b>	Block Transfer 15
↗	<b>09-26</b>	Block Transfer 16

Default: 0000h

## Settings 0000–FFFFh

- 📖 There is a group of block transfer parameters available in the AC motor drive (Pr. 09-11–Pr. 09-26). Using communication code 03H, you can store the parameters (Pr. 09-11–Pr. 09-26) that you want to read.
- 📖 For example: according to the Address List (as shown in the table below), Pr. 01-42 is shown as 012A. Set Pr. 09-11 to 012Ah (the minimum voltage of Pr. 01-42 M2 is 2.0V), and use Pr. 09-11 (communication address 090B) to read the communication parameter, the read value is 2.0.

AC motor drive parameters	GGnnH	GG is the parameter group, nn is the parameter number; for example, the address of Pr. 04-10 is 040AH.
---------------------------	-------	--

**09-30** Communication Decoding Method

Default: 1

Settings 0: Decoding Method 1 (20xx)

1: Decoding Method 2 (60xx)

		Decoding Method 1	Decoding Method 2
Source of Operation Control	Digital Keypad	Digital keypad controls the drive action regardless of decoding method 1 or 2.	
	External Terminal	External terminal controls the drive action regardless of decoding method 1 or 2.	
	RS-485	Refer to address: 2000h–20FFh	Refer to address: 6000h–60FFh
	CANopen	Refer to index: 2020-01h–2020-FFh	Refer to index:2060-01h–2060-FFh
	Communication Card	Refer to address: 2000h–20FFh	Refer to address: 6000h–60FFh
	PLC	PLC command controls the drive action regardless of decoding method 1 or 2.	

**09-31** Internal Communication Protocol

Default: 0

Settings 0: Modbus 485

- 1: Internal Communication Slave 1
- 2: Internal Communication Slave 2
- 3: Internal Communication Slave 3
- 4: Internal Communication Slave 4
- 5: Internal Communication Slave 5
- 6: Internal Communication Slave 6
- 7: Internal Communication Slave 7
- 8: Internal Communication Slave 8

-10: Internal Communication Master

-12: Internal PLC Control

 When it is defined as internal communication, refer to Section 16-10 for Main Control Terminal of Internal Communication.

 When it is defined as internal PLC control, refer to Section 16-12 for Remote IO control application (using MODRW).

**09-33** PLC Command Force to 0

Default: 0

- Settings
- bit0: Before PLC scan, set the PLC target frequency = 0
  - bit1: Before PLC scan, set the PLC target torque = 0
  - bit2: Before PLC scan, set the speed limit of torque control mode = 0

 Defines whether to clear the frequency command or speed command to 0 before the PLC scan time sequence.

**09-35** PLC Address

Default: 2

- Settings 1–254

**09-36** CANopen Slave Address

Default: 0

- Settings
- 0: Disable
  - 1–127

**09-37** CANopen Speed

Default: 0

- Settings
- 0: 1Mbps
  - 1: 500Kbps
  - 2: 250Kbps
  - 3: 125Kbps
  - 4: 100Kbps (Delta only)
  - 5: 50Kbps

**09-39** CANopen Warning Record

Default: Read only

- Settings
- bit0: CANopen Guarding Time-out
  - bit1: CANopen Heartbeat Time-out
  - bit2: CANopen SYNC Time-out
  - bit3: CANopen SDO Time-out
  - bit4: CANopen SDO buffer overflow
  - bit5: CANopen hardware disconnection warning (Can Bus OFF)
  - bit6: Error protocol of CANopen
  - bit8: The setting values of CANopen indexes are fail
  - bit9: The setting value of CANopen address is fail
  - bit10: The checksum value of CANopen indexes is fail

<b>09-40</b>	CANopen Decoding Method	Default: 1
	Settings 0: Disable (Delta-defined decoding method) 1: Enable (CANopen DS402 Standard protocol)	
<b>09-41</b>	CANopen Communication Status	Default: 0
	Settings 0: Node Reset State 1: Com Reset State 2: Boot up State 3: Pre-operation State 4: Operation State 5: Stop State	
<b>09-42</b>	CANopen Control Status	Default: Read Only
	Settings 0: Not ready for use state 1: Inhibit start state 2: Ready to switch on state 3: Switched on state 4: Enable operation state 7: Quick stop active state 13: Error reaction activation state 14: Error state	
<b>09-45</b>	CANopen Master Function	Default: 0
	Settings 0: Disable 1: Enable	
<b>09-46</b>	CANopen Master Address	Default: 100
	Settings 0–127	
<b>09-60</b>	Communication Card Identification	Default: Read only
	Settings 0: No communication card 1: DeviceNet Slave 2: Profibus-DP Slave 3: CANopen Slave / Master 4: MODBUS-TCP Slave 5: EtherNet / IP Slave 6: EtherCAT 12: PROFINET	

<b>09-61</b>	Firmware Version of Communication Card	Default: Read only
	Settings Read only	
<b>09-62</b>	Product Code	Default: Read only
	Settings Read only	
<b>09-63</b>	Error Code	Default: Read only
	Settings Read only	
<b>09-70</b>	Communication Card Address (for DeviceNet and PROFIBUS)	Default: 1
	Settings DeviceNet: 0–63 Profibus-DP: 1–125	
<b>09-71</b>	Communication Card Speed Setting (for DeviceNet)	Default: 2
	Settings Standard DeviceNet: 0: 125Kbps 1: 250Kbps 2: 500Kbps 3: 1Mbps (Delta only) Non-standard DeviceNet: (Delta only) 0: 10Kbps 1: 20Kbps 2: 50Kbps 3: 100Kbps 4: 125Kbps 5: 250Kbps 6: 500Kbps 7: 800Kbps 8: 1Mbps	
<b>09-72</b>	Other Communication Card Speed Setting (for DeviceNet)	Default: 0
	Settings 0: Standard DeviceNet In this mode, the baud rate can only be 125Kbps, 250Kbps, 500Kbps in standard DeviceNet speed. 1: Non-standard DeviceNet In this mode, the baud rate of DeviceNet can be the same as that for CANopen (0–8).	

 Use with Pr. 09-71.

 Setting 0: The baud rate can only be set to 125Kbps, 250Kbps and 500Kbps.

 Setting 1: The DeviceNet communication rate can be the same as that for CANopen (setting 0–8).

✎ **09-75** Communication Card IP Configuration (for MODBUS TCP)

Default: 0

Settings 0: Static IP  
1: Dynamic IP (DHCP)

---

 Setting 0: Set the IP address manually.

 Setting 1: IP address is automatically set by the host controller.

✎ **09-76** Communication Card IP Address 1 (for MODBUS TCP)

✎ **09-77** Communication Card IP Address 2 (for MODBUS TCP)

✎ **09-78** Communication Card IP Address 3 (for MODBUS TCP)

✎ **09-79** Communication Card IP Address 4 (for MODBUS TCP)

Default: 0

Settings 0–65535

---

 Use Pr. 09-76–09-79 with a communication card.

✎ **09-80** Communication Card Address Mask 1 (for MODBUS TCP)

✎ **09-81** Communication Card Address Mask 2 (for MODBUS TCP)

✎ **09-82** Communication Card Address Mask 3 (for MODBUS TCP)

✎ **09-83** Communication Card Address Mask 4 (for MODBUS TCP)

Default: 0

Settings 0–65535

---

✎ **09-84** Communication Card Gateway Address 1 (for MODBUS TCP)

✎ **09-85** Communication Card Gateway Address 2 (for MODBUS TCP)

✎ **09-86** Communication Card Gateway Address 3 (for MODBUS TCP)

✎ **09-87** Communication Card Gateway Address 4 (for MODBUS TCP)

Default: 0

Settings 0–65535

---

✎ **09-88** Communication Card Password (Low word) (for MODBUS TCP)

✎ **09-89** Communication Card Password (High word) (for MODBUS TCP)

Default: 0

Settings 0–99

---

✎ **09-90** Reset Communication Card (for MODBUS TCP)

Default: 0

Settings 0: Disable  
1: Reset, return to default

---

↗ **09-91** Additional Settings for the Communication Card (for MODBUS TCP)

Default: 1

Settings bit0: Enable IP Filter

bit1: Enable internet parameters (1bit)

When IP address is set, this bit is enabled. After updating the communication card parameters, this bit changes to disabled.

bit2: Enable login password (1bit)

When you enter the login password, this bit is enabled. After updating the communication card parameters, this bit changes to disable.

---

**09-92** Communication Card Status (for MODBUS TCP)

Default: 0

Settings bit0: Enable password

When the communication card is set with a password, this bit is enabled. When the password is cleared, this bit is disabled.

---

## 10 Speed Feedback Control Parameters

✎ This parameter can be set during operation.

In this parameter group, ASR stands for Adjust Speed Regulator and PG stands for Pulse Generator.

**10-00**

Encoder Type Selection

Default: 0

- Settings
- 0: Disabled
  - 1: ABZ
  - 2: ABZ (Delta encoder for Delta Servo motor)
  - 3: Resolver
  - 4: ABZ/UVW
  - 5: MI8 single phase pulse input

- 📖 When using PG expansion card EMC-PG01L or EMC-PG01O, set Pr.10-00=1. These expansion cards are applicable for induction motor (IM) only.
- 📖 When using EMC-PG01U, set Pr. 10-00=2 (Delta encoder), and make sure SW1 is switched to D (Delta type). If the setting for Pr. 10-00, Pr. 10-01 and Pr. 10-02 has changed, please turn off the drive's power and reboot to prevent permanent magnetic motor (PM) stall. This mode is recommended to use for PM.
- 📖 When using EMC-PG01U, set Pr. 10-00=4 (Standard ABZ/UVW Encoder), and make sure SW1 is switched to S (Standard Type). This mode is applicable for both IM and PM.
- 📖 When using EMC-PG01R, set Pr. 10-00=3, and set Pr. 10-01 to 1024 ppr, then set Pr. 10-30 after verifying the pole numbers of the resolver.
- 📖 When using MI8 single-phase pulse input as frequency command, the Pr. 10-02 must set to "5: Single-phase input". The drive calculates the MI8 single-phase pulse input speed when the control modes are VF, VFPG, SVC, IM/PM FOC Sensorless and IM/PM TQC Sensorless. If you use the MI8 single-phase pulse input for speed feedback in closed-loop control, you can only use it in VFPG closed-loop control mode.

**10-01**

Encoder Pulses per Revolution

Default: 600

Settings 1–20000

- 📖 This parameter sets the encoder pulses per revolution (ppr). It is a feedback control signal source when using PG. The encoder sets the number of pulses for the motor rotating through one rotation. The A/B phase cycle generates the pulse number.
- 📖 This setting is also the encoder resolution. The speed control is more accurate with higher resolution.
- 📖 If you set this parameter incorrectly, it may cause motor stall, drive over-current, or a magnetic pole origin detection error for the PM in closed-loop control. When using the PM, you must perform the pole zero point detection (Pr.05-00 = 4) again if you modify the content of this parameter.



## 10-02 Encoder Input Type Setting

Default: 0

Settings 0: Disable

1: A/B phase pulse input, run forward if the A-phase leads the B-phase by 90 degrees.

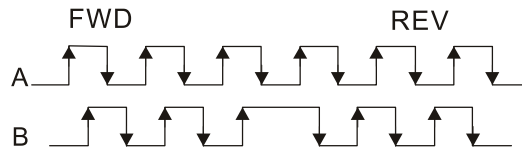

2: A/B phase pulse input, run forward if the B-phase leads the A-phase by 90 degrees.

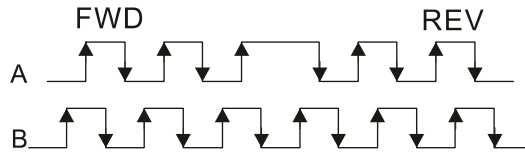

3: Phase A is a pulse input and phase B is a direction input (L = reverse direction, H = forward direction).

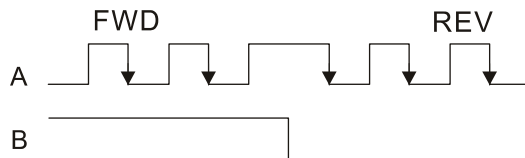

4: Phase A is a pulse input and phase B is a direction input (L = forward direction, H = reverse direction).

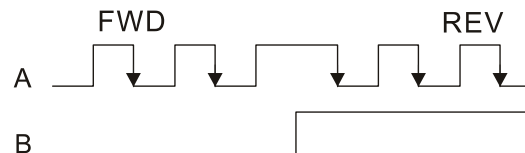

5: Single-phase input



Position control: the PG2 pulse affects the PG1 pulse tracking position.

1. When PG2 is single-pulse, and PG1 is A/B phase pulse, the frequency of position control should be  $(\text{input pps} \times 2) / (\text{PG1 ppr} \times 4)$  at constant speed.
2. When PG2 and PG1 are either single-pulse (or both A/B phase pulse), the frequency of position control should be  $(\text{input pps} \times 2) / (\text{PG1 ppr} \times 2)$  at constant speed.
3. Due to the edge trigger of the pulse input, the input of A/B phase pulse should be read as 4 times of the frequency; and the single-phase input should be read as twice of the frequency. For inputs with the same pps, the single-phase tracking frequency will be half of the double-phase frequency.



Velocity control: PG2 acts according to the setting for Pr. 10-01 (PG1 ppr), and will not be affected by PG1 pulse (single-phase input or A/B phase pulse). When the setting for Pr. 10-00, Pr.

10-01 and Pr. 10-02 are changed, cycle the power of the motor drive.

1. The speed formula is (input ppr) / (PG1 ppr), when PG1 ppt = 2500, PG2 is single-phase input, and the input pps is 1000 (1000 pulse per second), the speed should be  $(1000 / 2500) = 0.40\text{Hz}$ .
2. The same pps inputs of A/B phase pulse or single-phase pulse input should get the same frequency command.

### 10-03 Frequency Division Output Setting (Denominator)

Default: 1

Settings 1–255

📖 Sets the denominator for the frequency division of the PG card feedback and output. When you set it to 2 with feedback 1024 ppr, PG OUT (pulse output) of PG card is  $1024 / 2 = 512$  ppr.

### 10-04 Electrical Gear at Load Side A1

### 10-05 Electrical Gear at Motor Side B1

### 10-06 Electrical Gear at Load Side A2

### 10-07 Electrical Gear at Motor Side B2

Default: 100

Settings 1–65535

📖 Use Pr. 10-04–Pr. 10-07 with the multi-function input terminal (set to 48) to switch to Pr. 10-04–Pr. 10-05 or Pr. 10-06–Pr. 10-07, as the following shows.

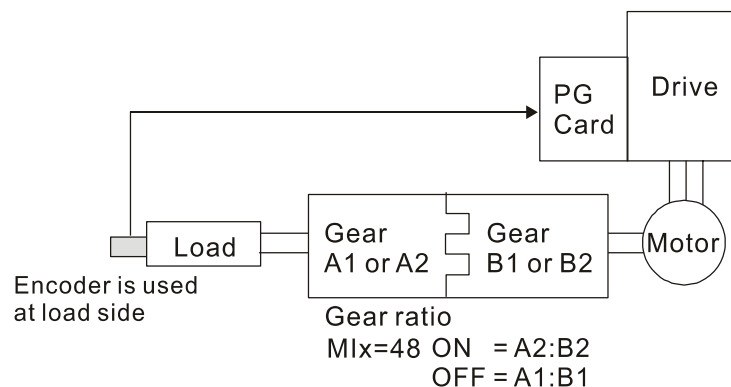

### 10-08 Treatment for Encoder / Speed Observer Feedback Fault

Default: 2

Settings 0: Warn and continue operation

1: Warn and ramp to stop

2: Warn and coast to stop

### 10-09 Detection Time of Encoder / Speed Observer Feedback Fault

Default: 1.0

Settings 0.0–10.0 sec.

0: Disable

📖 When there is an encoder loss, an encoder signal error, a pulse signal setting error or a signal error, if the duration exceeds the detection time for the encoder feedback fault (Pr. 10-09), the encoder signal error occurs. Refer to Pr. 10-08 for encoder feedback fault treatment.

 When the speed controller signal is abnormal, if time exceeds the detection time for the encoder feedback fault (Pr. 10-09), the feedback fault occurs. Refer to Pr. 10-08 for the encoder feedback fault treatment.

 **10-10** Encoder / Speed Observer Stall Level

Default: 115

Settings 0–120%  
0: No function

 This parameter determines the maximum encoder feedback signal allowed before a fault occurs. The maximum operation frequency for Pr.01-00 = 100%

 **10-11** Detection Time of Encoder / Speed Observer Stall

Default: 0.1

Settings 0.0–2.0 sec.

 **10-12** Encoder / Speed Observer Stall Action

Default: 2

Settings 0: Warn and continue operation  
1: Warn and ramp to stop  
2: Warn and coast to stop

 When the drive output frequency exceeds the encoder/ speed observer stall level (Pr. 10-10), the drive start to count the time. When the error time exceeds the encoder/ speed observer stall detection time (Pr. 10-11), the drive implements the encoder stall treatment.

 **10-13** Encoder / Speed Observer Slip Range

Default: 50

Settings 0–50%  
0: Disable

 **10-14** Detection Time of Encoder/ Speed Observer Slip

Default: 0.5

Settings 0.0–10.0 sec.

 **10-15** Encoder / Speed Observer Stall and Slip Error Action

Default: 2

Settings 0: Warn and continue operation  
1: Warn and ramp to stop  
2: Warn and coast to stop

 This parameter acts on the settings for Pr. 10-13–Pr. 10-15:  
When the value of (rotation speed – motor frequency) exceeds the Pr. 10-13 setting, and the detection time exceeds Pr. 10-14; the drive starts to count the time. If the detection time exceeds Pr. 10-14, the encoder feedback signal error occurs. Refer to Pr.10-15 for the encoder stall and slip error treatment.

**10-16** Pulse Input Type Setting

Default: 0

Settings 0: Disable

1: A/B phase pulse input, run forward if the A-phase leads the B-phase by 90 degrees.

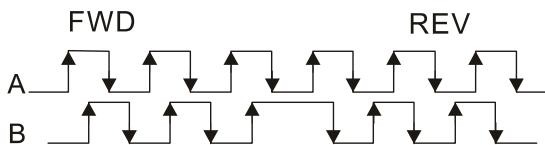

2: A/B phase pulse input, run forward if the B-phase leads the A-phase by 90 degrees.

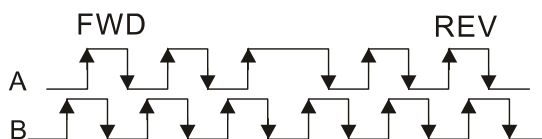

3: Phase A is a pulse input and phase B is a direction input (L = reverse direction, H = forward direction).

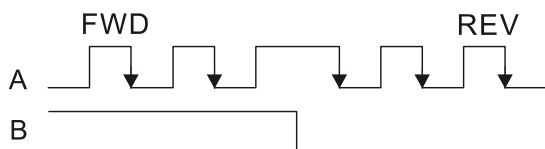

4: Phase A is a pulse input and phase B is a direction input (L = forward direction, H = reverse direction).

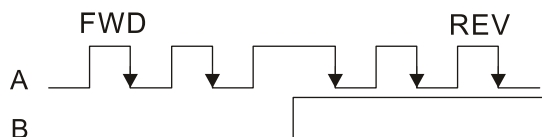

5: MI8 single-phase pulse input

When this setting is different from the Pr. 10-02 setting and the source of the frequency command is pulse input (Pr. 00-20 set to 4 or 5), it causes a four-time frequency problem .

Example:

Assume that Pr. 10-01=1024, Pr. 10-02=1, Pr. 10-16=3, Pr. 00-20=5, Mlx = 37 and ON, then the pulse needed to rotate the motor one revolution is 4096 (1024\*4).

Assume that Pr. 10-01=1024, Pr. 10-02=1, Pr. 10-16=1, Pr. 00-20=5, Mlx = 37 and ON, the pulse needed to rotate the motor one revolution is 1024 (1024\*1).

Position control diagram

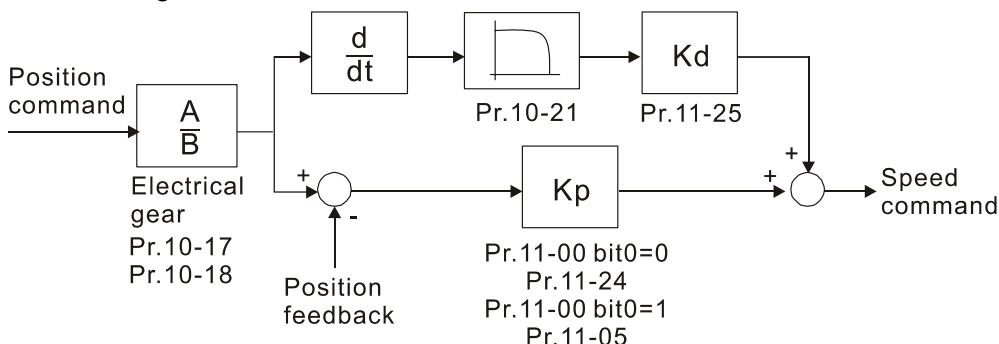

- 📖 Setting procedure of MI8 single-phase pulse input:  
Pr. 00-20=4, Pulse input without direction command  
Pr.10-01 set as the ppr number of each rotation.  
Pr.10-16=5, MI8 single-phase pulse input

📖 MI8 input and PG2 input could both exist at the same time. But PG card Pr. 10-00 and Pr. 10-16 cannot be set as MI8 at the same time.

↗ **10-17** Electrical Gear A

↗ **10-18** Electrical Gear B

Default: 100

Settings 1–65535

📖 Rotation speed = pulse frequency / encoder pulses (Pr. 10-01) \* Electrical Gear A / Electrical Gear B.

↗ **10-19** Positioning for Encoder Position

Default: 0

Settings -32767–2400

- 📖 Determines the internal position in the position mode.
- 📖 Use this with the multi-function input terminal setting = 35 (enable position control).
- 📖 When set to 0, it is the Z-phase position of the encoder.
- 📖 The setting range is affected by Pr. 10-01 and Pr. 10-02.

Example:

When Pr. 10-01 = 2500, Pr. 10-02 = 1 or 2, the setting range for Pr. 10-19 is -32767–10000.

When Pr. 10-01 = 1024, Pr. 10-02 = 1 or 2, the setting range for Pr. 10-19 is -32767–4096.

When Pr. 10-01 = 2500, Pr. 10-02 = 3, 4 or 5, the setting range for Pr. 10-19 is -32767–2500.

↗ **10-20** Error Range for Encoder Position Reached

Default: 10

Settings 0–65535 pulses

📖 This parameter determines the range for the internal positioning position reached.

Example:

When you set the position for Pr.10-19 (Positioning for Encoder Position) and Pr.10-20 to 1000, it reaches the position if the position is between 990–1010 after positioning.

↗ **10-21** Filter Time (PG2)

Default: 0.100

Settings 0.000–65.535 sec.

📖 When you set Pr. 00-20 to 5 and the multi-function input terminal to 37 (OFF), the system treats the pulse command as a Frequency command. Use this parameter to suppress the speed command jump.

### 10-24 FOC & TQC Function Control

Default: 0

- Settings bit0: ASR controller under torque control  
(0: use PI as ASR; 1: use P as ASR)
- bit11: Activate DC brake when executing the zero torque command  
(0: ON; 1: OFF)
- bit12: FOC Sensorless mode, crossing zero means the speed goes from negative to positive or positive to negative  
(0: determined by stator frequency; 1: determined by speed command)
- bit15: Direction control in open-loop status  
(0: Switch ON direction control; 1: Switch OFF direction control)

 Set bit = 0 for closed-loop; any other bit setting for open-loop.

### 10-25 FOC Bandwidth for Speed Observer

Default: 40.0

Settings 20.0–100.0Hz

 Setting the speed observer to a higher bandwidth could shorten the speed response time but creates greater noise interference during the speed observation.

### 10-26 FOC Minimum Stator Frequency

Default: 2.0

Settings 0.0–10.0% fN

 Use this parameter to set the stator frequency minimum level in operation status. This setting ensures the stability and accuracy of observer and avoids interferences from voltage, current and motor parameter. fN is the motor rated frequency.

### 10-27 FOC Low-pass Filter Time Constant

Default: 50

Settings 1–1000ms

 This parameter sets the low-pass filter time constant of a flux observer at start-up. If you cannot activate the motor during high speed operation, lower the setting for this parameter.

### 10-28 FOC Gain of Excitation Current Rise Time

Default: 100

Settings 33–100%Tr (Tr: rotor time constant)

 Sets the drive's excitation current rise time when it activates in sensorless torque mode. When the drive's activation time is too long in torque mode, adjust this parameter to a shorter time value.

### 10-29 Top Limit of Frequency Deviation

Default: 20.00

Settings 0.00–200.00Hz

 Limits the maximum frequency deviation.

 If you set this parameter too high, an abnormal feedback malfunction occurs.

 If the application needs a higher setting for Pr. 10-29, note that a higher setting results in larger motor slip, which causes a PG Error (PGF3, PGF4). In this case, you can set Pr. 10-10 and Pr. 10-13 to 0 to disable PGF3 and PGF4 detection, but you must make sure the PG wiring and application are correct; otherwise, it may lose the instant PG protection. Pr. 10-29 setting too high is not commonly done.

**10-30** Resolver Pole Pair Default: 1

Settings 1–50

---

 To use the Pr. 10-30 function, you must set Pr. 10-00=3 (Resolver Encoder) first.

**10-31** I/F Mode, Current Command Default: 40

Settings 0–150% of motor rated current

---

 Sets the current command for the drive in low speed area (low speed area: frequency command < Pr. 10-39). When the motor stalls on heavy-duty start-up or forward/ reverse with load, increase the parameter value. If the inrush current is too high and causes oc stall, then decrease the parameter value.

**10-32** PM FOC Sensorless Speed Estimator Bandwidth Default: 5.00

Settings 0.00–600.00Hz

---

 Sets the speed estimator bandwidth. Adjust the parameter to change the stability and the accuracy of the motor speed.

 If there is low frequency vibration (the waveform is similar to sine wave) during the process, then increase the bandwidth. If there is high frequency vibration (the waveform shows extreme vibration and is like a spur), then decrease the bandwidth.

**10-34** PM Sensorless Speed Estimator Low-pass Filter Gain Default: 1.00

Settings 0.00–655.35

---

 Changes the response speed of the speed estimator.

 If there is low frequency vibration (the waveform is similar to the sine wave) during the process, then increase the gain. If there is high frequency vibration (the waveform shows extreme vibration and is like a spur), then decrease the gain.

**10-35** ARM (Kp) Gain Default: 1.00

Settings 0.00–3.00

---

**10-36** ARM (Ki) Gain Default: 0.20

Settings 0.00–3.00

---

 Active Magnetic Regulator Kp / Ki, affects the response of magnetic regulation in the low magnetic area.

 If entering the low magnetic area and the input voltage (or DC BUS) plummets (e.g. an unstable power net causes instant insufficient voltage, or a sudden load that makes DC BUS drop), which causes the ACR diverge and oc, then increase the gain. If the Id value of a spur creates large noise in high-frequency output current, decrease the gain to reduce the noise. Decrease the gain will slow down the response.

### **10-37** PM Sensorless Control Word

Default: 0000h



Settings 0000–FFFFh

bit No.	Function	Description
2	Choose a control mode to start.	0: Start in IF mode 1: Start in VF mode
3	Choose a mode to stop.	0: Stop in IF mode 1: Stop in VF mode
5	Choose a control mode to stop	0: When lower than Pr. 10-40, coast to stop 1: When lower than Pr. 10-40, ramp to stop

### **10-39** Frequency Point to Switch from I/F Mode to PM Sensorless Mode

Default: 20.00



Settings 0.00–599.00Hz

-  Sets the frequency for the switch point from low frequency to high frequency.
-  If the switch point is too low, the motor does not generate enough back-EMF to let the speed estimator measure the rotor right position and speed, and causes stall and oc when running at the switch point frequency
-  If the switch point is too high, the active area of I/F is too wide, which generates more current and cannot save energy. If the current value for Pr. 10-31 is too high, the high switch point makes the drive continue to output with the setting value for Pr. 10-31.

### **10-40** Frequency Point to Switch from PM Sensorless Mode to I/F Mode

Default: 20.00

Settings 0.00–599.00Hz

-  Sets the switch point from high frequency to low frequency.
-  If the switch point is too low, the motor does not generate enough back-EMF to let the speed estimator measure the rotor right position and speed when running at the switch point frequency.
-  If the switch point is too high, the active area of I/F is too wide, which generates more current and cannot save energy. If the current of Pr. 10-31 is too high, the high switch point makes the drive continue to output with the setting value for Pr. 10-31).

### **10-41** I/F Mode, Id Current Low Pass-Filter Time

Default: 0.2

Settings 0.0–6.0 sec.



-  Sets the filter time for Pr. 10-31. Smoothly increases the magnetic field to the current command setting value under the I/F mode.



 If you want to slowly increase the size of Id, increase the filter time to avoid a Step phenomenon occurs when starting current output. When decrease the filter time (minimum value is 0), the current rises faster, then a Step phenomenon occurs.

 **10-42** Initial Angle Detection Pulse Value Default: 1.0

Settings 0.0–3.0

-  The angle detection is fixed to 3: Use the pulse injection method to start. The parameter influences the value of the pulse during the angle detection. The larger the pulse, the higher the accuracy of rotator's position. A larger pulse might cause oc.
-  Increase the parameter when the running direction and the command are opposite during start-up. If oc occurs at start-up, then decrease the parameter.
-  Refer to Section 12-2 Adjustment & Application for detailed motor adjustment procedure.

**10-43** PG Card Version Default: Read only





Settings 0.00–655.35

 Corresponding version reference:

PG02U	21.XX
PG01U	31.XX
PG01O / PG01L	11.XX
PG02O / PG02L	14.XX
PG01R	41.XX



 **10-49** Zero Voltage Time during Start-up Default: 00.000

Settings 00.000–60.000 sec.

-  This parameter is valid only when the setting of Pr. 07-12 (Speed Tracking during Start-up) = 0.
-  When the motor is in static status at start-up, this increases the accuracy when estimating angles. In order to put the motor in static state, set the three-phase drive output to 0 V to the motor. The Pr. 10-49 setting time is the length of time when three-phase output at 0 V.
-  It is possible that even when you apply this parameter, the motor cannot go into the static state because of inertia or some external force. If the motor does not go into the static state in 0.2 seconds, increase this setting value appropriately.
-  If Pr. 10-49 is too high, the start-up time is longer. If it is too low, then the braking performance is weak.

 **10-50** Reverse Angle Limit (Electrical Angle) Default: 10.00

Settings 0.00–30.00 degree

-  When the drive is running forward, if a sudden reverse run occurs and the reverse angle exceeds the setting for Pr. 10-50, then a ScRv error occurs.
-  This parameter is valid only when the setting of Pr. 07-28 =11 (enable textile machine).
-  If the estimated tolerance of start-up angle detection is larger, and causes a reverse run of the motor, this parameter can limit the reverse angle.

- Decrease the parameter setting to prevent large reverse angle. If the tolerance is bigger, then increase the parameter setting. If the load is too large at this moment, it may cause oc.

### 10-51 Injection Frequency

Default: 500

Settings 0–1200Hz

- This parameter is a high frequency injection command in IPM-HFI-sensorless control mode and usually you do not need to adjust it. If a motor's rated frequency (for example, 400Hz) is too close to the frequency setting for this parameter (that is, the Default of 500Hz), it affects the accuracy of the angle detection. Refer to the setting for Pr. 01-01 before you adjust this parameter.
- If the setting value for Pr. 00-17 is lower than Pr. 10-51\*10, then increase the frequency of the carrier wave.
- Pr. 10-51 is valid only when Pr. 10-53=2.

### 10-52 Injection Magnitude

Default:

15.0/ 30.0/ 30.0/ 30.0

Settings 0.0–200.0V  
 230V series: 0.0–100.0V  
 460V series: 0.0–200.0V  
 575V series: 0.0–200.0V  
 690V series: 0.0–200.0V

- The parameter is the magnitude command for the high frequency injection signal in IPM Sensorless control mode.
- Increasing the parameter can increase the accuracy of the angle estimation, but the electromagnetic noise might be louder if the setting value is too high.
- The system uses this parameter when the motor's parameter is "Auto". This parameter influences the angle estimation accuracy.
- When the ratio of the salient pole ( $L_q/L_d$ ) is lower, increase Pr. 10-52 to make the angle detection more accurate.
- Pr. 10-52 is valid only when Pr. 10-53=2.

### 10-53 PM Initial Rotor Position Detection Method

Default: 0

Settings 0: Disable  
 1: Internal 1/4 rated current attracting the rotor to zero degrees  
 2: High frequency injection  
 3: Pulse injection

- Set to 2 for IPM; set to 3 for SPM. If these settings cause problems, then set the parameter to 1.

# 11 Advanced Parameters

✎ This parameter can be set during operation.

In this parameter group, ASR stands for Adjust Speed Regulator

**11-00** System Control

Default: 0000h

- Settings bit0: Auto-tuning for ASR and APR
- bit1: Inertia estimate (only in FOCPG mode)
- bit2: Zero servo
- bit6: 0Hz linear-cross
- bit7: Save or do not save the frequency
- bit8: Maximum speed for point-to-point position control

📖 bit0=0: Manual adjustment for ASR and APR gain, Pr. 11-06–Pr. 11-11 are valid and Pr. 11-03–Pr. 11-05 are invalid.

bit0=1: Auto-adjustment for ASR and APR gain, the system automatically generates an ASR setting, Pr. 11-06–Pr. 11-11 are invalid and Pr. 11-03–Pr. 11-05 are valid.

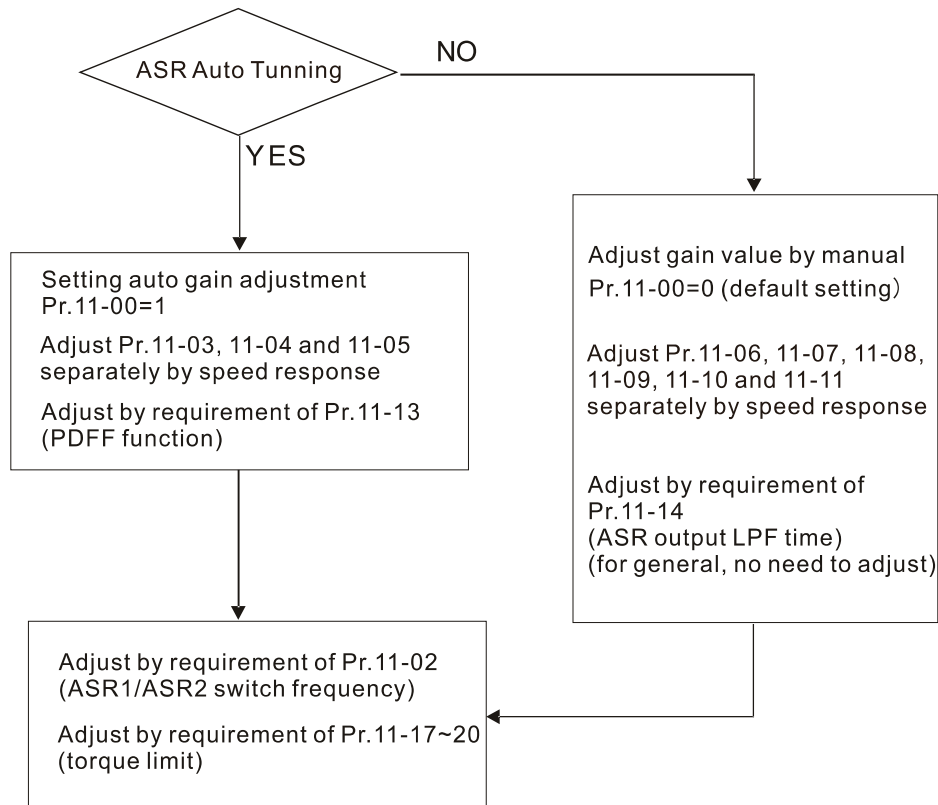

📖 When the drive needs to keep a certain torque at zero-speed, or it needs a steady frequency output at extreme low speed, increase Pr. 11-05 zero-speed bandwidth appropriately. When the speed is in high-speed area, if the output current trembles seriously and makes the drive vibrate, then decrease the high-speed bandwidth.

For example:

Manual gain	Response: [Pr. 11-10, Pr. 11-11] > [Pr. 11-06, Pr. 11-07] > [Pr. 11-08, Pr. 11-09]
Auto gain	Pr. 11-05 = 15 Hz, Pr. 11-03 = 10 Hz, Pr. 11-04 = 8 Hz

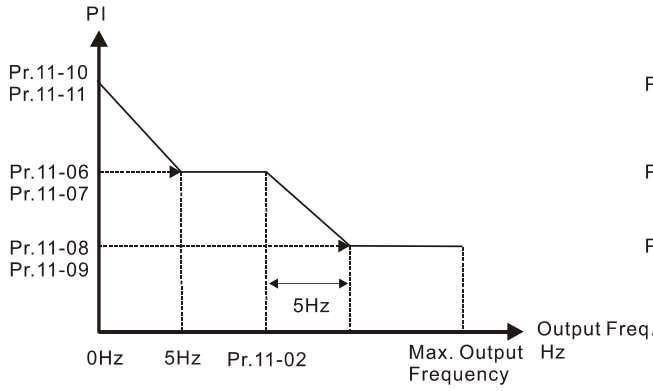

ASR adjustment- manual gain

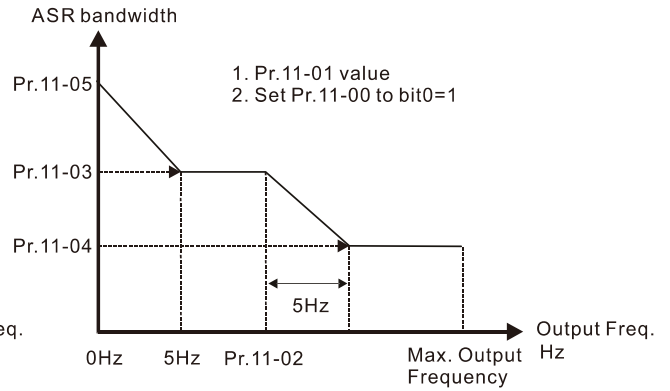

ASR adjustment- auto gain

bit1=0: no function.

bit1=1: Inertia estimation function is enabled. bit1 setting would not activate the estimation process, set Pr. 05-00=12 to begin FOC/TQC Sensorless inertia estimating.

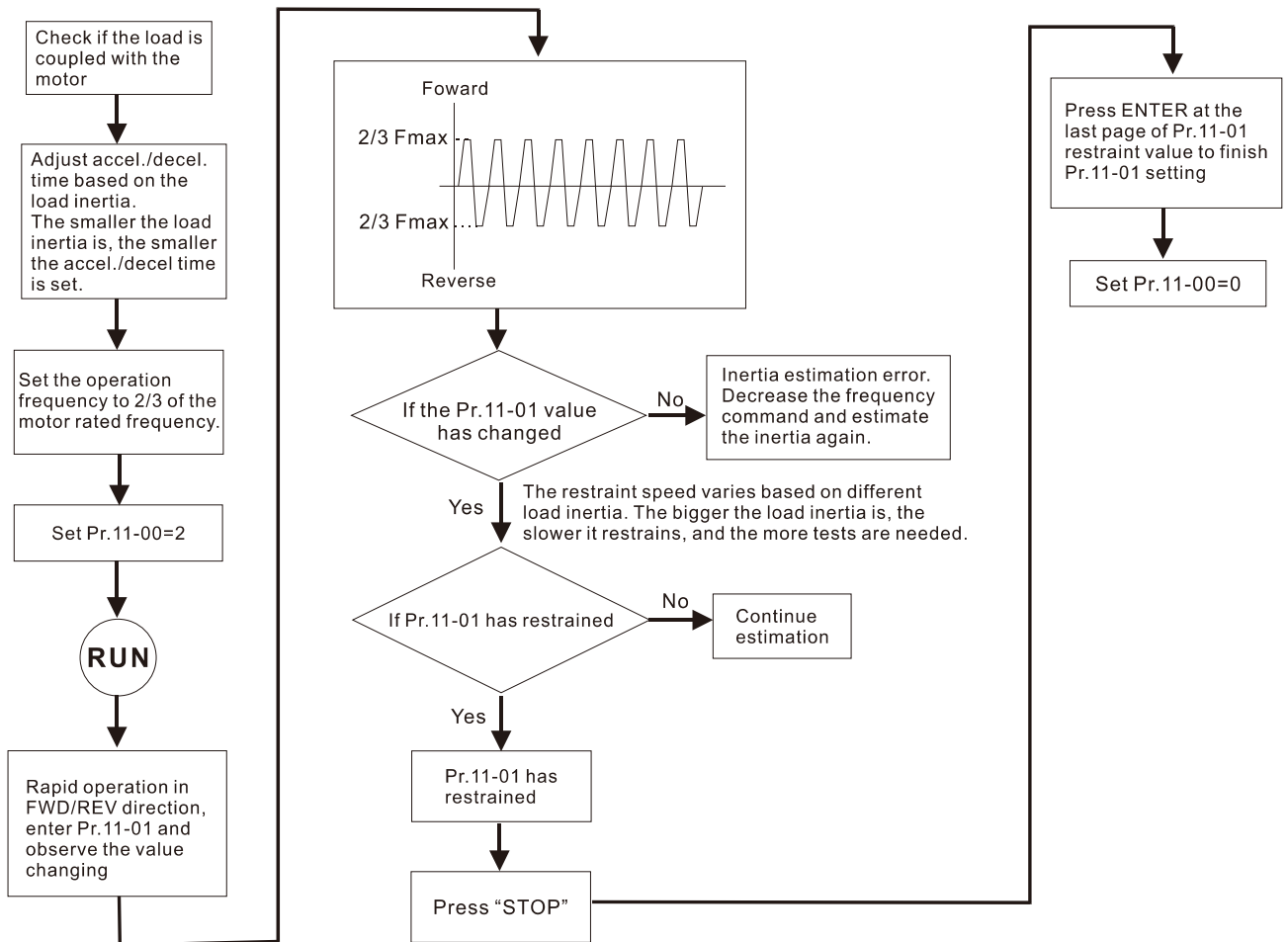

bit2=0: no function.

bit2=1: when frequency command is less than Fmin (Pr. 01-07), it will use the zero-servo function as position control.

bit6 0Hz linear-cross function: keeps the S-Curve in linear-cross the 0Hz point when the S acceleration/ deceleration curves (Pr. 01-24–Pr. 01-27) are set, and the forward/ reverse run cross 0Hz.

bit6=1: The S acceleration/ deceleration curves (Pr. 01-24–Pr. 01-27) do NOT affect the drive

starts and stops. Forward / reverse rotation crosses the zero point in linear.

bit6=0: The S acceleration / deceleration curves (Pr. 01-24–Pr. 01-27) affect the drive starts and stops. Forward / reverse rotation crosses the zero point after the S-Curve.

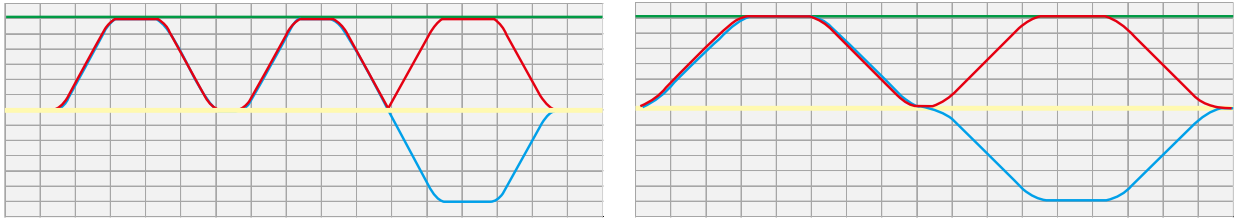

Output frequency

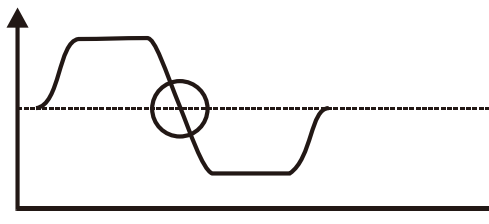

Pr. 11-00 bit6=1

Output frequency

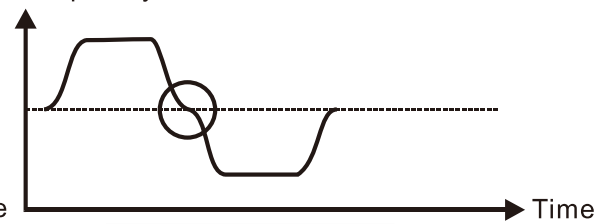

Pr. 11-00 bit6=1

- 📖 bit 7=0: Save the frequency before power is OFF. When power is ON again, the saved frequency is displayed.
- bit7=1: Do not save the frequency before power is OFF. When power is ON again, 0.00 Hz is the displayed frequency.
- 📖 bit8=0: Pr. 11-43 sets the maximum speed for point-to-point position control
- bit8=1: The external multi-speed terminal sets the maximum speed for point-to-point position control. When the external multi-speed terminal is 0, Pr. 11-43 sets the maximum speed.

**11-01** Per Unit of System Inertia

Default: 256

Settings 1–65535 (256=1PU)

- 📖 To get the system inertia from Pr. 11-01, user needs to set Pr. 11-00 to bit1 = 1 and execute continuous forward/reverse running.
- 📖 When Pr. 11-01 = 256, it is 1PU. So if you use a 2HP motor, the 2HP motor inertia is 4.3 kg-cm<sup>2</sup> according to the table below. If Pr. 11-01 = 10000 after tuning, the system inertia is (10000 / 256) x 4.3 kg-cm<sup>2</sup>.
- 📖 Perform the operation test with load based on the inertia after tuning. Run the motor in acceleration, deceleration, and steady speed and observe the values. If values between speed feedback and speed command are close, steady-state error is small and overshoot is less, then this inertia is a better one.
- 📖 If the Iq current command from ASR has high-frequency glitch, then decrease the setting. If the response time of sudden loading is too slow, then increase the setting.
- 📖 When using torque mode as the control mode, perform the tuning with speed mode first to see if the tuned inertia can work normally. After verifying with speed mode, change the control mode to torque mode.

Unit of induction motor system inertia is kg-cm<sup>2</sup>:

Power	Setting	Power	Setting	Power	Setting
1HP	2.3	25HP	142.8	175HP	2150.0
2HP	4.3	30HP	176.5	250HP	2800.0
3HP	8.3	40HP	202.5	300HP	3550.0
5HP	14.8	50HP	355.5	375HP	5139.0
7.5HP	26.0	60HP	410.8	425HP	5981.0
10HP	35.8	75HP	494.8	475HP	7053.0
12HP	54.8	100HP	1056.5	600HP	9643.0
15HP	74.3	125HP	1275.3	650HP	10734.0
20HP	95.3	150HP	1900.0	750HP	13000.0

The base value for induction motor system inertia is set by Pr. 05-38 and the unit is in kg-cm<sup>2</sup>.

### 11-02 ASR1 / ASR2 Switch Frequency

Default: 7.00

Settings 5.00–599.00Hz

 Sets the low-speed and high-speed ASR switching point in the FOC area. Provides flexibility to meet two needs: in the high-speed region of the estimator switch point it has a high response, and in the low-speed region of the estimator switch point it has a lower response. The recommended switching point is higher than Pr. 10-39.

 A low setting does not cover Pr. 10-39. If the setting is too high, the high-speed range is too narrow.

### 11-03 ASR1 Low-speed Bandwidth

Default: 10

Settings 1–40Hz (IM) / 1–100Hz (PM)

### 11-04 ASR2 High-speed Bandwidth

Default: 10

Settings 1–40Hz (IM) / 1–100Hz (PM)

### 11-05 Zero-speed Bandwidth

Default: 10

Settings 1–40Hz (IM) / 1–100Hz (PM)

 After estimating inertia and setting Pr. 11-00 bit0=1 (auto-tuning), you can adjust Pr. 11-03, Pr. 11-04 and Pr. 11-05 separately according to the speed response. The larger the setting value, the faster the response. Pr. 11-02 is the switch frequency for the low-speed / high-speed bandwidth.

 The position control pulse command (MIx=37) and P2P position control Kp gain can adjust Pr. 11-05. The higher the value, the lower the steady-state error.

### 11-06 ASR 1 Gain

Default: 10

Settings 0–40 Hz (IM) / 1–100Hz (PM)

### 11-07 ASR 1 Integral Time

Default: 0.100

Settings 0.000–10.000 sec.

↗	<b>11-08</b> ASR 2 Gain	Default: 10
	Settings 0–40 Hz (IM) / 0–100Hz (PM)	
↗	<b>11-09</b> ASR 2 Integral Time	Default: 0.100
	Settings 0.000–10.000 sec.	
↗	<b>11-10</b> ASR Gain of Zero Speed	Default: 10
	Settings 0–40 Hz (IM) / 0–100Hz (PM)	
↗	<b>11-11</b> ASR Integral Time of Zero Speed	Default: 0.100
	Settings 0.000–10.000 sec.	
↗	<b>11-12</b> ASR Speed Feed Forward Gain	Default: 0
	Settings 0–150%	

- 📖 This function enables when Pr. 11-00 bit0 = 1.
- 📖 Increase the setting for Pr.11-12 to reduce the command tracking difference, and improve the speed response. Use this function for speed tracking applications.
- 📖 Set Pr.11-01 correctly to get excellent improvement of the speed response.

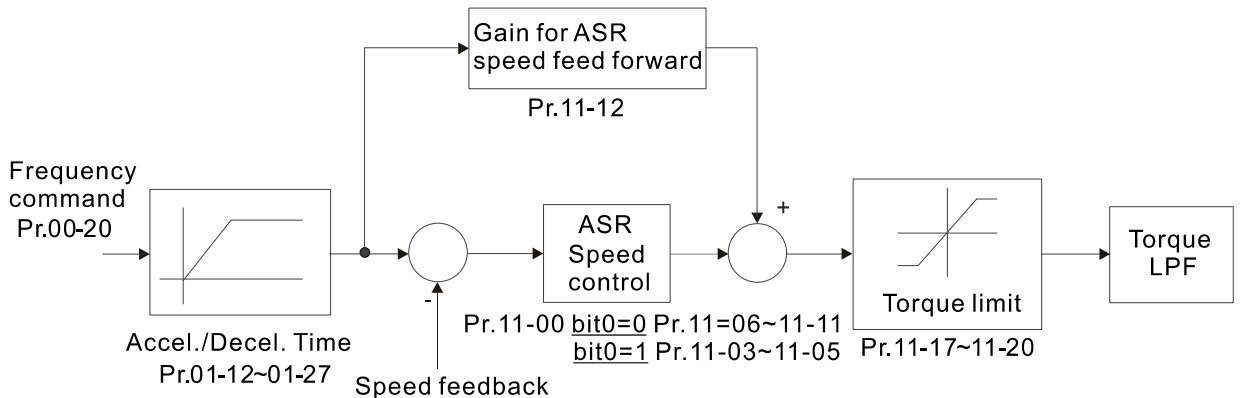

↗	<b>11-13</b> PDF Gain Value	Default: 30
	Settings 0–200%	

- 📖 This parameter is invalid when Pr. 05-24 = 1.
- 📖 This parameter is valid only when Pr. 11-00 bit0 = 1.
- 📖 After you finish estimating and set Pr. 11-00 bit0=1 (auto-tuning), use Pr. 11-13 to reduce overshoot, but a shift of the curve may occur earlier. Set Pr. 11-13 = 0, when the acceleration time fits the applicable demand, but an overshoot occurs, increase Pr. 11-13 to “the best acceleration without overshoot”.
- 📖 Increase Pr. 11-13 to improve the overshoot of speed tracking, but an excessive value may reduce the transient response.
- 📖 Increase Pr. 11-13 to enhance the system stiffness in high-speed steady state, and reduce the speed transient fluctuation at suddenly loading.

📖 Set Pr.11-01 correctly to get excellent improvement of the speed response.

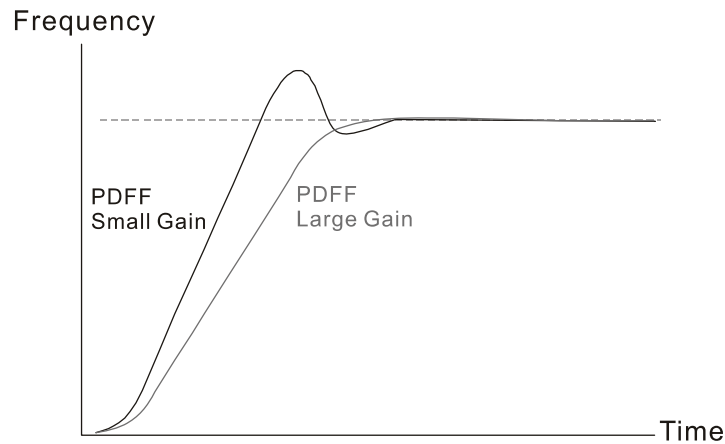

↗ **11-14** ASR Output Low-pass Filter Time

Default: 0.008

Settings 0.000–0.350 sec.

📖 Use this to set the ASR command filter time.

↗ **11-15** Notch Filter Depth

Default: 0

Settings 0–20db

↗ **11-16** Notch Filter Frequency

Default: 0.00

Settings 0.00–200.00Hz

📖 Sets the resonance frequency of mechanical system and suppresses the mechanical system resonance.

📖 The higher the setting value for Pr. 11-15, the better the mechanical resonance is suppressed.

📖 The notch filter frequency is the mechanical frequency resonance.

↗ **11-17** Forward Motor Torque Limit Quadrant I

↗ **11-18** Forward Regenerative Torque Limit Quadrant II

↗ **11-19** Reverse Motor Torque Limit Quadrant III

↗ **11-20** Reverse Regenerative Torque Limit Quadrant IV

Default: 500

Settings 0–500%

📖 FOC PG & FOC Sensorless mode:

The drive rated current = 100%. The setting value for Pr. 11-17–Pr. 11-20 is compared with Pr. 03-00 = 7, 8, 9, 10. The minimum of the comparison result is the torque limit. Refer to the torque limit diagram below.

📖 TQCPG and TQC Sensorless mode:

The function of Pr. 11-17–Pr. 11-20 is the same as FOC; however, in this case, the torque command limits the output torque. The minimum value between Pr. 11-17–11-20 and Pr. 06-12 becomes the current output torque limit.

📖 VF, VFPG and SVC mode:



Pr. 11-17–Pr. 11-20 limit the output current, the percentage base value is the drive’s rated current (not the motor’s rated current). The minimum value between Pr. 11-17–11-20 and Pr.06-12 becomes the current output limit. In acceleration and steady state operation, when the output current reaches the limit, the ocA (over-current during acceleration) protection or over-current stall prevention under steady-state operation acts. The output frequency drops, and recovers when the output current is lower than the limit value.

📖 Calculation equation for the motor rated torque:

$$\text{Motor rated torque} = T(N.M) = \frac{P(W)}{\omega(rad/s)}; P(W) \text{ value} = \text{Pr. 05-02 (Pr. 05-14)};$$

$$\omega(rad/s) \text{ value} = \text{Pr. 05-03 (Pr. 05-15)}; \frac{RPM \times 2\pi}{60} = rad/s$$

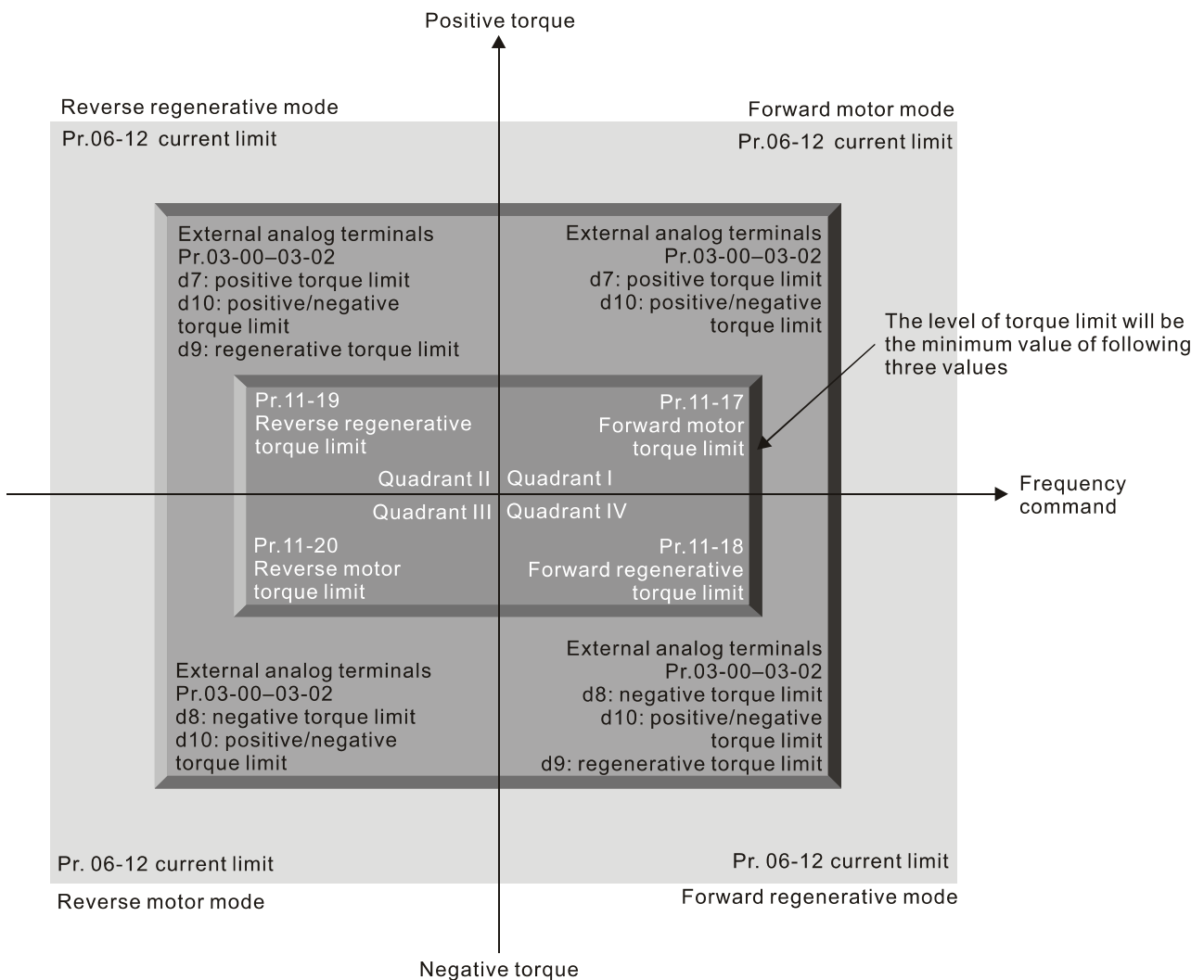

📖 The control mode is based on 100% motor rated current except for these four modes:  
IM: VF, VFPG, SVC / PM: PMSVC modes.

⚡ **11-21** Flux Weakening Curve for Motor 1 Gain Value

Default: 90

Settings 0–200%

### 11-22 Flux Weakening Curve for Motor 2 Gain Value

Default: 90

Settings 0–200%

- 📖 Adjusts the output voltage for the flux-weakening curve.
- 📖 For the spindle application, use this adjustment method:
  1. Use it to adjust the output voltage when exceeding rated frequency.
  2. Monitor the output voltage.
  3. Adjust the Pr. 11-21 (motor 1) or Pr. 11-22 (motor 2) setting to make the output voltage reach the motor rated voltage.
  4. The larger the setting value, the greater the output voltage.

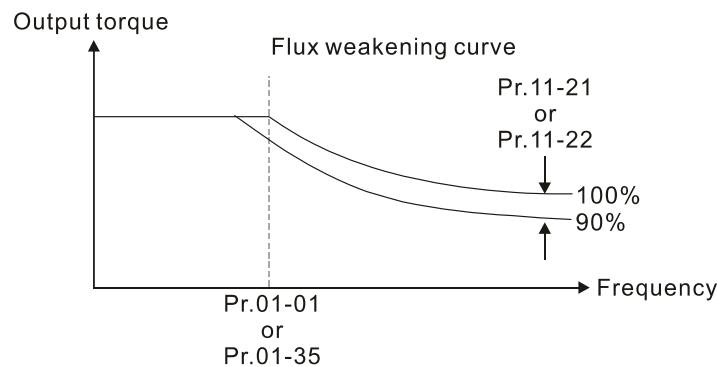

### 11-23 Flux Weakening Area Speed Response

Default: 65

Settings 0: Disable  
0–150%

- 📖 Controls the speed in the flux weakening area. The larger the value set for Pr. 11-23, the faster the acceleration/deceleration. In general, you do not need to adjust this parameter.

### 11-24 APR Gain

Default: 10.00

Settings 0.00–40.00 (IM) / 0–100.00Hz (PM)

- 📖 Sets the Kp gain of the internal position (Mlx=35).

### 11-25 Gain Value for the APR Feed Forward

Default: 30

Settings 0–100

- 📖 This applies only to the internal position (Mlx = 35) and position control pulse command (Mlx = 37). A larger value can shorten the pulse differential and speed up the position response; however, it may cause overshoot.

### 11-26 APR Curve Time

Default: 3.00

Settings 0.00–655.35 sec.

- 📖 This is valid when the multi-function input terminal is set to 35 (ON). The larger the setting value, the longer the position time.

➤ **11-27** Max. Torque Command

Default: 100

Settings 0–500%

- 📖 Determines the upper limit of the torque command (motor rated torque is 100%).
- 📖 Calculation equation for the motor rated torque:

Motor rated torque:  $T(N.M) = \frac{P(W)}{\omega(rad/s)}$ ; P(W) value = Pr. 05-02 (Pr. 05-14);

$\omega(rad/s)$  value = Pr. 05-03 (Pr. 05-15);  $\frac{RPM \times 2\pi}{60} = rad/s$

➤ **11-28** Torque Offset Source

Default: 0

- Settings
- 0: Disable
  - 1: Analog signal input (Pr. 03-00)
  - 2: Pr. 11-29
  - 3: Controlled by external terminal (Pr. 11-30–Pr. 11-32)

- 📖 Determines the source for the torque offset.
- 📖 When it is set to 3 (external terminal control), the torque offset source follows Pr. 11-30, Pr. 11-31 or Pr. 11-32 as the combination of MIx setting as 31, 32 or 33 commands. Refer to the following chart:

Normally open (N.O.) contact: ON= contact closed, OFF= contact open

Pr. 11-32	Pr. 11-31	Pr. 11-30	Torque Offset
MIx = 33 (Low)	MIx = 32 (Mid)	MIx = 31 (High)	
OFF	OFF	OFF	None
OFF	OFF	ON	Pr. 11-30
OFF	ON	OFF	Pr. 11-31
OFF	ON	ON	Pr. 11-30 + Pr. 11-31
ON	OFF	OFF	Pr. 11-32
ON	OFF	ON	Pr. 11-30 + Pr. 11-32
ON	ON	OFF	Pr. 11-31 + Pr. 11-32
ON	ON	ON	Pr. 11-30 + Pr. 11-31 + Pr. 11-32

➤ **11-29** Torque Offset Setting













Default: 0.0

Settings -100.0%–100.0%

- 📖 Determines the torque offset command. The motor rated torque is 100%.
- 📖 The calculation equation for the motor rated torque:

Motor rated torque:  $T(N.M) = \frac{P(W)}{\omega(rad/s)}$ ; P(W) value = Pr. 05-02 (Pr. 05-14);

$\omega(rad/s)$  value = Pr. 05-03 (Pr. 05-15);  $\frac{RPM \times 2\pi}{60} = rad/s$

-  **11-30** High Torque Compensation Default: 30.0  
 Settings -100.0%–100.0%
- 
-  **11-31** Middle Torque Compensation Default: 20.0  
 Settings -100.0%–100.0%
- 
-  **11-32** Low Torque Compensation Default: 10.0  
 Settings -100.0%–100.0%
- 
-  When Pr. 11-28 is set to 3, the torque-offset source uses Pr. 11-30, Pr. 11-31 or Pr. 11-32 determined by the multi-function input terminals setting (31, 32 or 33). The motor rated torque is 100%.
-  The calculation equation for the motor rated torque:
- Motor rated torque:  $T(N.M) = \frac{P(W)}{\omega(rad/s)}$ ; P(W) value = Pr. 05-02 (Pr. 05-14);
- $\omega(rad/s)$  value = Pr. 05-03 (Pr. 05-15);  $\frac{RPM \times 2\pi}{60} = rad/s$
- 
-  **11-33** Torque Command Source Default: 0  
 Settings 0: Digital Keypad  
 1: RS-485 communication (Pr. 11-34)  
 2: Analog signal input (Pr. 03-00)  
 3: CANopen  
 5: Communication expansion card
- 
-  When you set Pr. 11-33 to 0 or 1, set the torque command in Pr. 11-34.
-  When you set Pr. 11-33 to 2, 3 or 5, Pr. 11-34 only displays the torque command.
- 
-  **11-34** Torque Command Default: 0.0  
 Settings -100.0–100.0% (Pr. 11-27=100%)
- 
-  This parameter is for the torque command. When you set Pr. 11-27 to 250% and Pr. 11-34 to 100%, the actual torque command =  $250 \times 100\% = 250\%$  motor rated torque.
-  The drive saves the setting before power is OFF.
- 
-  **11-35** Torque Command Filter Time Default: 0.000  
 Settings 0.000–1.000 sec.
- 
-  When the setting is too long, the control is stable but the control response is delayed. When the setting is too short, the response is quick but the control may be unstable. Adjust the setting according to the stability of the control and response for the application.

**11-36** Speed Limit Selection

Default: 0

Settings 0: Set by Pr. 11-37 (Forward Speed Limit) and Pr. 11-38 (Reverse Speed Limit)

1: Set by Pr. 11-37, Pr. 11-38 and Pr. 00-20 (Source of Master Frequency Command)

2: Set by Pr. 00-20 (Source of Master Frequency Command).

Speed limit function: when you use the torque control mode, if the torque command is greater than the load, the motor accelerates until the motor speed equals the speed limit. At this time, it switches to speed control mode to stop acceleration.

Pr. 11-36=1:

When the torque command is positive, the forward speed limit is Pr. 00-20 and the reverse speed limit is Pr. 11-38.

When the torque command is negative, the forward speed limit is Pr. 11-37 and the reverse speed limit is Pr. 00-20.

For example: In an unwind application, the torque command direction is different from the motor operating direction, and this indicates that the load drives the motor. The speed limit must be Pr. 11-37 or Pr. 11-38. In normal applications, when the motor drives the load and the torque command is in the same direction as the speed limit, only then you can set the speed limit according to Pr. 00-20.

About the keypad display, refer to the LED function descriptions in Chapter10 “Digital Keypad”. In torque control, the F page of keypad displays the present speed limit value.

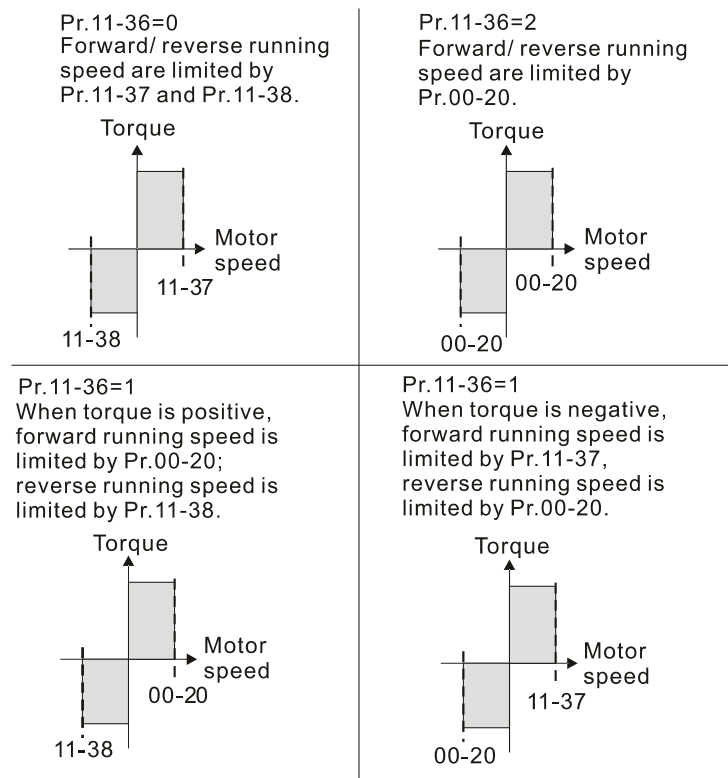

**11-37** Forward Speed Limit (Torque Mode)

Default: 10

Settings 0–120%

**11-38** Reverse Speed Limit (Torque Mode)

Default: 10

Settings 0–120%

These parameters define the speed limit in the forward and reverse directions in torque mode (Pr. 01-00 maximum operation frequency = 100%).

**11-39** Zero Torque Command Mode Selection

Default: 0

Settings 0: Torque mode  
1: Speed mode

This parameter is only valid in TQCPG IM and TQCPG PM, and it defines the mode when the speed limit is 0% or 0Hz.

When you set Pr. 11-39 to 0, and the speed limit is 0% or 0Hz, the motor generates an excitation current, and the torque command Pr. 11-34 limits the torque.

When you set Pr. 11-39 to 1, and the speed limit is 0% or 0Hz, the AC motor drive can generate output torque through the speed controller (the torque limit is Pr. 06-12), and the control mode changes from TQC + PG to FOC + PG mode. The motor has a holding torque. If the speed command is not 0, the drive automatically changes it to 0.

**11-40** Point-to-Point Position Control Command Source

Default: 0

Settings 0: External terminal  
2: RS-485  
3: CANopen  
5: Communication card

**11-42** System Control Flag

Default: 0000h

Settings 0000–FFFFh

bit No.	Function	Description
0	Current limit selection of the speed control in torque mode	0: The speed control in torque mode, the maximum current limit is the torque command. 1: The speed control in torque mode, the maximum current limit is Pr. 06-12.
1	FWD / REV action control	0: FWD/ REV cannot be controlled by Pr. 02-12 bit0 & 1 1: FWD/ REV can be controlled by Pr. 02-12 bit0 & 1

**11-43** Point- to-Point Position Control Maximum Frequency

Default: 10.00

Settings 0.00–599.00Hz

**11-44** Point-to-Point Position Control Acceleration Time

Default: 1.00

Settings 0.00–655.35 sec.

**11-45** Point-to-Point Position Control Deceleration Time

Default: 3.00

Settings 0.00–655.35 sec.

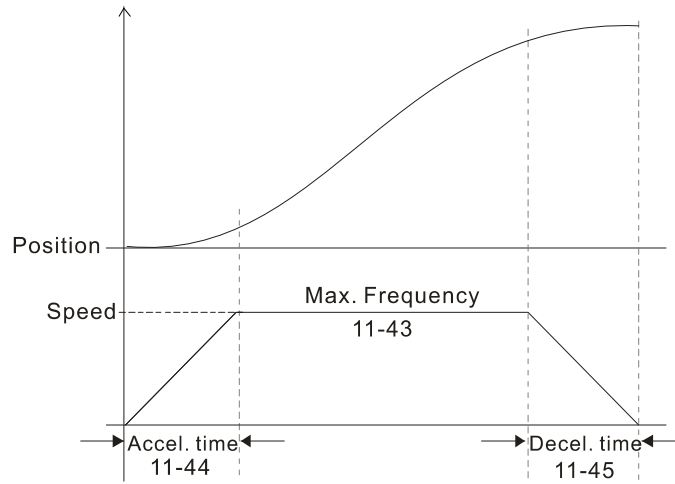

**11-46** Torque Output Filter Gain

Default: 0.050

Settings 0.000–65.535

- Sets the filter gain of the torque output display (keypad display and communication read), including Pr. 00-04 = 8 displays the output torque (%) that the drive calculates, the output torque (XXX.X %) of communication address 210B and the positive / negative output torque (%) that 2208 drive calculates (XXX.X %).

# 13 Application Parameters by Industry

✎ This parameter can be set during operation.

**13-00** Application Selection

Default: 0

- Settings
- 0: Disabled
  - 1: User-defined Parameter
  - 2: Compressor (IM)
  - 3: Fan
  - 4: Pump
  - 10: Air Handling Unit, AHU

 Note: after you select the macro, some of the default values adjust automatically according to the application selection.

 Group setting 02: Compressor (IM)

The following table lists the relevant compressor application parameters.

Pr.	Explanation	Settings
00-11	Speed control mode	0 (V/F control)
00-16	Load selection	0 (Normal load)
00-17	Carrier frequency	Default setting
00-20	Master frequency command source (AUTO) / Source selection of the PID target	2 (External analog input)
00-21	Operation command source (AUTO)	1 (External terminals)
00-22	Stop method	0 (Ramp to stop)
00-23	Control of motor direction	1 (Disable reverse)
01-00	Maximum operation frequency	Default setting
01-01	Output frequency of motor 1	Default setting
01-02	Output voltage of motor 1	Default setting
01-03	Mid-point frequency 1 of motor 1	Default setting
01-04	Mid-point voltage 1 of motor 1	Default setting
01-05	Mid-point frequency 2 of motor 1	Default setting
01-06	Mid-point voltage 2 of motor 1	Default setting
01-07	Minimum output frequency of motor 1	Default setting
01-08	Minimum output voltage of motor 1	Default setting
01-11	Output frequency lower limit	20 (Hz)
01-12	Acceleration time 1	20 (s)
01-13	Deceleration time 1	20 (s)
03-00	Analog input selection (AVI)	0 (No function)
03-01	Analog input selection (ACI)	1 (Frequency command)
05-01	Full-load current for induction motor 1 (A)	Default setting
05-03	Rated speed for induction motor 1 (rpm)	Default setting
05-04	Number of poles for induction motor 1	Default setting



 Group setting 03: Fan

The following table lists the relevant fan setting application parameters.

Pr.	Explanation	Settings
00-11	Speed control mode	0 (V/F control)
00-16	Load selection	0 (Normal load)
00-17	Carrier frequency	Default setting
00-20	Master frequency command source (AUTO) / Source selection of the PID target	2 (External analog input)
00-21	Operation command source (AUTO)	1 (External terminals)
00-22	Stop method	1 (Coast to stop)
00-23	Control of motor direction	1 (Disable reverse)
00-30	Master frequency command (HAND) source	0 (Digital keypad)
00-31	Operation Command (HAND) source	0 (Digital keypad)
01-00	Maximum operation frequency	Default setting
01-01	Output frequency of motor 1	Default setting
01-02	Output voltage of motor 1	Default setting
01-03	Mid-point frequency 1 of motor 1	Default setting
01-04	Mid-point voltage 1 of motor 1	Default setting
01-05	Mid-point frequency 2 of motor 1	Default setting
01-06	Mid-point voltage 2 of motor 1	Default setting
01-07	Minimum output frequency of motor 1	Default setting
01-08	Minimum output voltage of motor 1	Default setting
01-10	Output frequency upper limit	50 (Hz)
01-11	Output frequency lower limit	35 (Hz)
01-12	Acceleration time 1	15 (s)
01-13	Deceleration time 1	15 (s)
01-43	V/F curve selection	2 (Second V/F curve)
02-05	Multi-function input command 5 (MI5)	16 (Rotating speed command from ACI)
03-00	Analog input selection (AVI)	1 (Frequency command)
03-01	Analog input selection (ACI)	1 (Frequency command)
03-28	AVI terminal input selection	0 (0–10 V)
03-29	ACI terminal input selection	1 (0–10 V)
03-31	AFM output selection	0 (0–10 V)
03-50	Analog input curve selection	1 (three-point curve of AVI)
07-06	Restart after momentary power loss	2 (Speed tracking by minimum output frequency)
07-11	Number of times of restart after fault	5 (times)
07-33	Auto-restart interval of fault	60 (s)

 Group setting 04: Pump

The following table lists the relevant pump setting application parameters.

Pr.	Explanation	Settings
00-11	Speed control mode	0 (V/F control)
00-16	Load Selection	0 (Normal load)
00-20	Master frequency command source (AUTO) / Source selection of the PID target	2 (External analog input)
00-21	Operation command source (AUTO)	1 (External terminals)
00-23	Control of motor direction	1 (Disable reverse)
01-00	Maximum operation frequency	Default setting
01-01	Output frequency of motor 1	Default setting
01-02	Output voltage of motor 1	Default setting
01-03	Mid-point frequency 1 of motor 1	Default setting
01-04	Mid-point voltage 1 of motor 1	Default setting
01-05	Mid-point frequency 2 of motor 1	Default setting
01-06	Mid-point voltage 2 of motor 1	Default setting
01-07	Minimum output frequency of motor 1	Default setting
01-08	Minimum output voltage of motor 1	Default setting
01-10	Output frequency upper limit	50 (Hz)
01-11	Output frequency lower limit	35 (Hz)
01-12	Acceleration time 1	15 (s)
01-13	Deceleration time 1	15 (s)
01-43	V/F curve selection	2 (Second V/F curve)
07-06	Restart after momentary power loss	2 (Speed tracking by minimum output frequency)
07-11	Number of times of restart after fault	5
07-33	Auto-restart interval of fault	60 (s)

 Group setting 10: Air Handling Unit, AHU

The following table lists the relevant AHU setting application parameters.

Pr	Explanation	Settings
00-04	Content of multi-function display	2
00-11	Speed control mode	0 (V/F control)
00-16	Load Selection	0 (Normal load)
00-20	Master frequency command source (AUTO) / Source selection of the PID target	2 or 0
00-21	Operation command source (AUTO)	1 or 0
00-22	Stop method	1 (Coast to stop)
00-23	Control of motor direction	1 (Disable reverse)
00-30	Master frequency command (HAND) source	0 (Digital keypad)
00-31	Operation Command (HAND) source	0 (Digital keypad)
01-00	Maximum operation frequency	50
01-01	Output frequency of motor 1	50
01-02	Output voltage of motor 1	380
01-07	Minimum output frequency of motor 1	0.1
01-10	Output frequency upper limit	50
01-11	Output frequency lower limit	35
01-34	Zero-speed mode	2
01-43	V/F curve selection	2
02-05	Multi-function input command 5 (MI5)	16 or 17
02-13	Multi-function output 1 RLY1	11
02-14	Multi-function output 2 RLY2	1
03-00	Analog input selection (AVI)	1
03-01	Analog input selection (ACI)	1
03-02	Analog input selection (AUI)	1
03-28	AVI terminal input selection	0
03-29	ACI terminal input selection	1
03-20	Multi-function output 1 (AFM1)	0
03-23	Multi-function output 2 (AFM2)	0
03-31	AFM2 output selection	0 or 1
03-50	Analog input curve selection	4 (three-point curve of AUI)
07-06	Restart after momentary power loss	2 (Speed tracking by minimum output frequency)
07-11	Number of times of restart after fault	5 (times)
07-33	Auto-restart interval of fault	60 (s)

## 14 Extension Card Parameter

✎ This parameter can be set during operation.

✎ **14-00** Extension Card Input Terminal Selection (AI10)

✎ **14-01** Extension Card Input Terminal Selection (AI11)

Default: 0

- Settings
- 0: Disable
  - 1: Frequency command
  - 2: Torque command (torque limit in speed mode)
  - 3: Torque compensation command
  - 4: PID target value
  - 5: PID feedback signal
  - 6: Thermistor (PTC / KTY-84) input value
  - 7: Positive torque limit
  - 8: Negative torque limit
  - 9: Regenerative torque limit
  - 10: Positive / negative torque limit
  - 11: PT100 thermistor input value
  - 13: PID compensation amount

 When the setting for Pr. 14-00 and Pr. 14-01 are the same, the AI10 is selected first.

✎ **14-08** Analog Input Filter Time (AI10)

✎ **14-09** Analog Input Filter Time (AI11)

Default: 0.01

Settings 0.00–20.00 sec.

 The input analog signal of terminal AI1 and AI2 often includes interferences, which will affect the stability of the control. Use these input delays to filter a noisy analog signal.

 When the setting for the time constant is too large, the control is stable but the control response is slow. When the setting for time constant is too small, the control response is faster but the control may be unstable. For optimal setting, adjust the setting according to the control stability or the control response.

✎ **14-10** Analog Input 4–20mA Signal Loss Selection (AI10)

✎ **14-11** Analog Input 4–20mA Signal Loss Selection (AI11)

Default: 0

- Settings
- 0: Disable
  - 1: Continue operation at the last frequency
  - 2: Decelerate to 0Hz
  - 3: Stop immediately and display ACE

 This parameter determines the treatment when the 4–20 mA signal is lost, when Pr. 14-18 = 2, Pr. 14-19 = 2.

- 📖 When the setting for Pr. 14-18 or Pr. 14-19 are 0 or 1, the voltage input to AVI and ACI terminal is 0–10 V or 4–20 mA. At this moment, Pr. 14-10 and Pr. 14-11 are invalid.
- 📖 Setting 1 or 2: Displays the warning code “ANL” on the keypad. It continues blinking until the lost ACI signal is recovered.
- 📖 When the motor drive stops, the warning condition does not continue to exist, so the warning disappears.

↗ **14-12** Extension Card Output Terminal Selection (AO10)

↗ **14-13** Extension Card Output Terminal Selection (AO11)

Default: 0

Settings 0–23

📖 Refer to the function chart below for details setting.

Function Chart

Settings	Functions	Descriptions
0	Output frequency (Hz)	Maximum frequency Pr.01-00 is processed as 100%.
1	Frequency command (Hz)	Maximum frequency Pr.01-00 is processed as 100%.
2	Motor speed (Hz)	Maximum frequency Pr.01-00 is processed as 100%.
3	Output current (rms)	(2.5 × rated current) is processed as 100%
4	Output voltage	(2 × rated voltage) is processed as 100%
5	DC BUS voltage	450V (900V)=100%
6	Power factor	-1.000–1.000=100%
7	Power	(2 × rated power) is processed as 100%
8	Torque	Full load torque = 100%
9	AVI	0–10 V = 0–100%
10	ACI	4–20 mA = 0–100%
11	AUI	-10–10V = 0–100%
12	Iq current command	(2.5 × rated current) is processed as 100%
13	Iq feedback value	(2.5 × rated current) is processed as 100%
14	Id current command	(2.5 × rated current) is processed as 100%
15	Id feedback value	(2.5 × rated current) is processed as 100%
18	Torque command	Rated torque of motor = 100%
19	PG2 frequency command	Maximum frequency Pr.01-00 is processed as 100%.
20	CANopen analog output	For CANopen communication analog output
21	RS-485 analog output	For RS-485 (InnerCOM / MODBUS) analog output
22	Communication card analog output	For communication analog output (CMC-MOD01, CMC-EIP01, CMC-PN01, CMC-DN01)
23	Constant voltage output	Pr. 03-32 controls the voltage output level. 0–100% of Pr. 03-32 corresponds to 0–10V of AFM.
25	CANopen and RS-485 analog output	For CANopen and InnerCOM control output

↗ **14-14** Analog Output 1 Gain (AO10)

↗ **14-15** Analog Output 1 Gain (AO11)

Default: 100.0

Settings 0.0–500.0%

📖 Adjusts the voltage level outputted to the analog meter from the analog signal (Pr. 14-12, Pr. 14-13) output terminal AFM of the drive.

↗ **14-16** Analog Output 1 in REV Direction (AO10)

↗ **14-17** Analog Output 1 in REV Direction (AO11)

Default: 0

Settings 0: Absolute output voltage value

1: Reverse output 0V; forward output 0–10V

2: Reverse output 5–0V; forward output 5–10V

📖 Determines the voltage reverse output when AO10 and AO11 are set as 0–10 V (Pr. 14-36 = 2, Pr. 14-37 = 2).

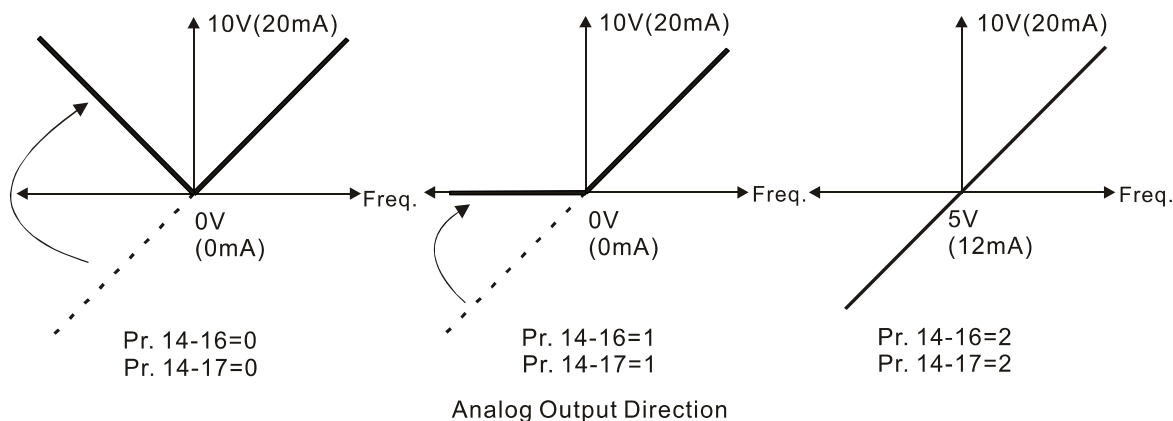

↗ **14-18** Extension Card Input Selection (AI10)

Default: 0

Settings 0: 0–10V (AVI10)

1: 0–20mA (ACI10)

2: 4–20mA (ACI10)

↗ **14-19** Extension Card Input Selection (AI11)

Default: 0

Settings 0: 0–10V (AVI11)

1: 0–20mA (ACI11)

2: 4–20mA (ACI11)

📖 When you change the input mode, verify that the switch position of external terminal (AI10, AI11) is correct.

↗ **14-20** AO10 DC Output Setting Level

↗ **14-21** AO11 DC Output Setting Level

Default: 0.00

Settings 0.00–100.00%

↗ **14-22** AO10 Filter Output Time

↗ **14-23** AO11 Filter Output Time

Default: 0.01

Settings 0.00–20.00 sec.

---

↗ **14-36** AO10 Output Selection

↗ **14-37** AO11 Output Selection

Default: 0

Settings 0: 0–10V

1: 0–20mA

2: 4–20mA

---

# 12-2 Adjustment & Application

## 12-2-1 Standard IM Motor Adjustment Procedure

Flow chart

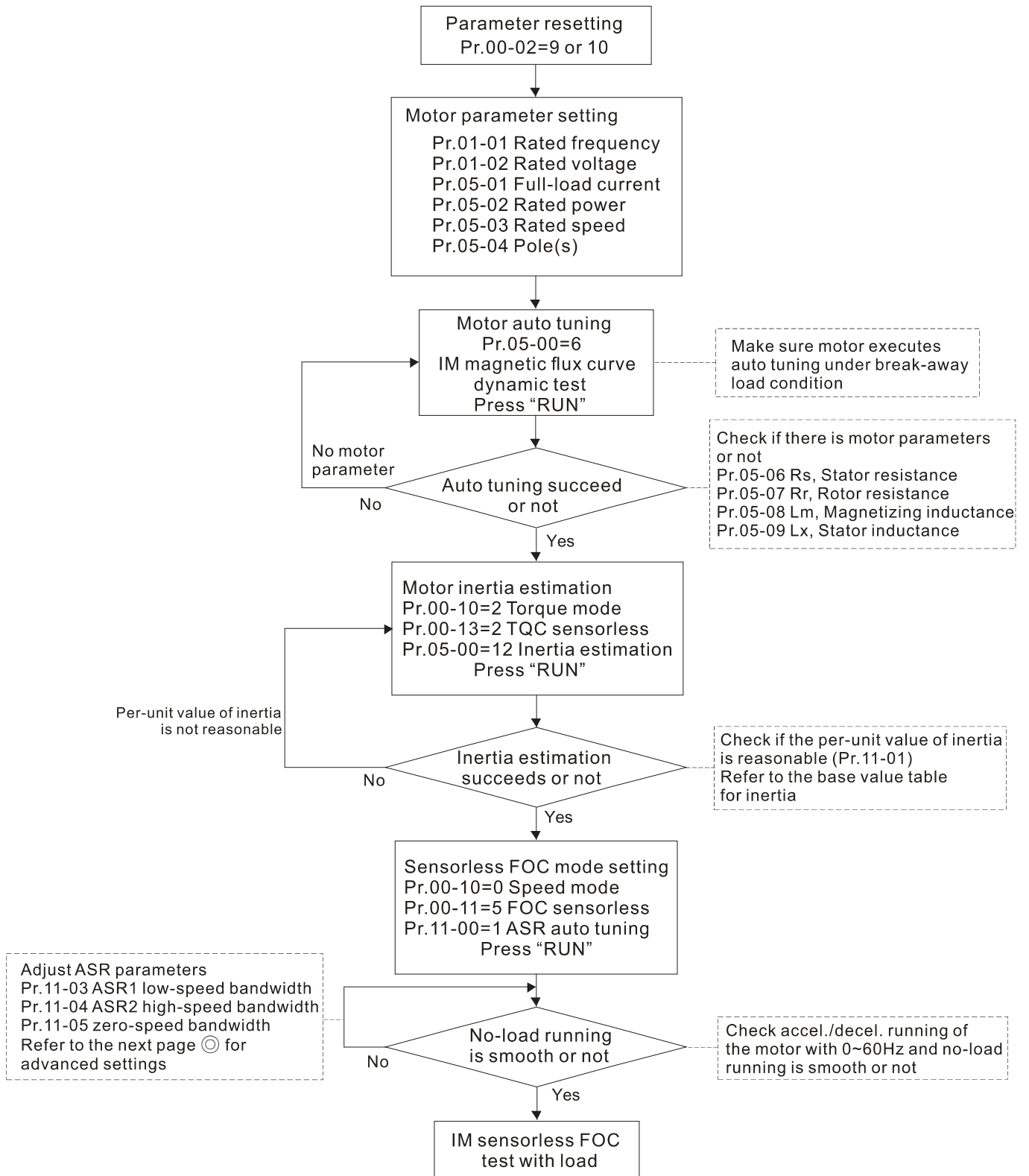



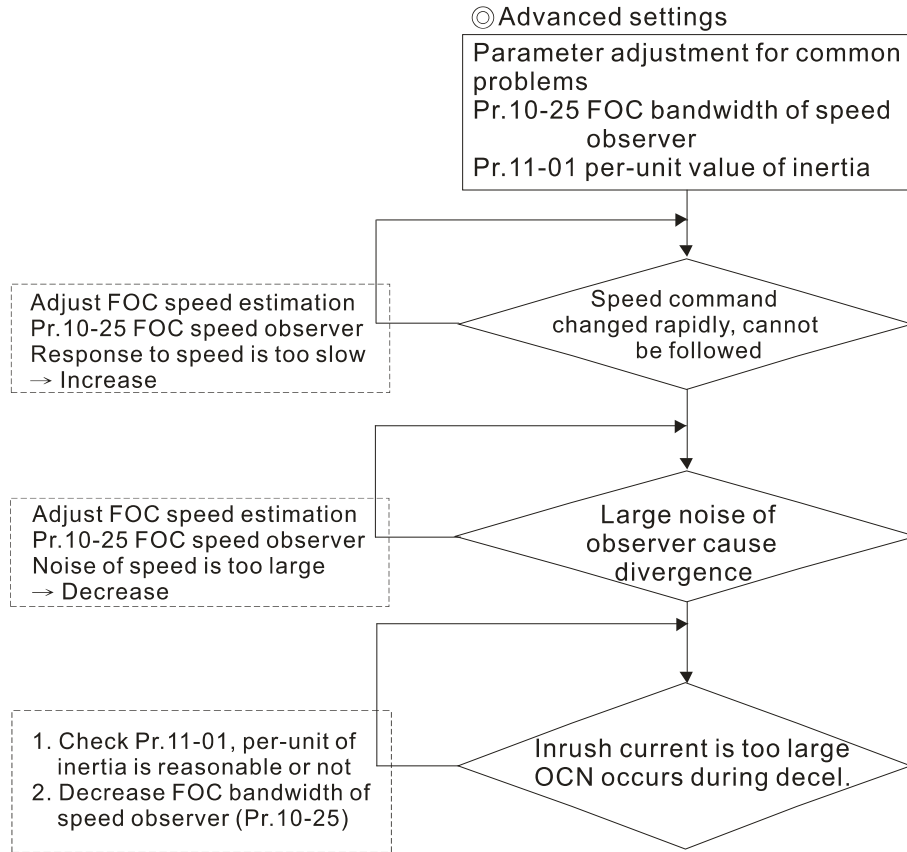

FOC sensorless control diagram

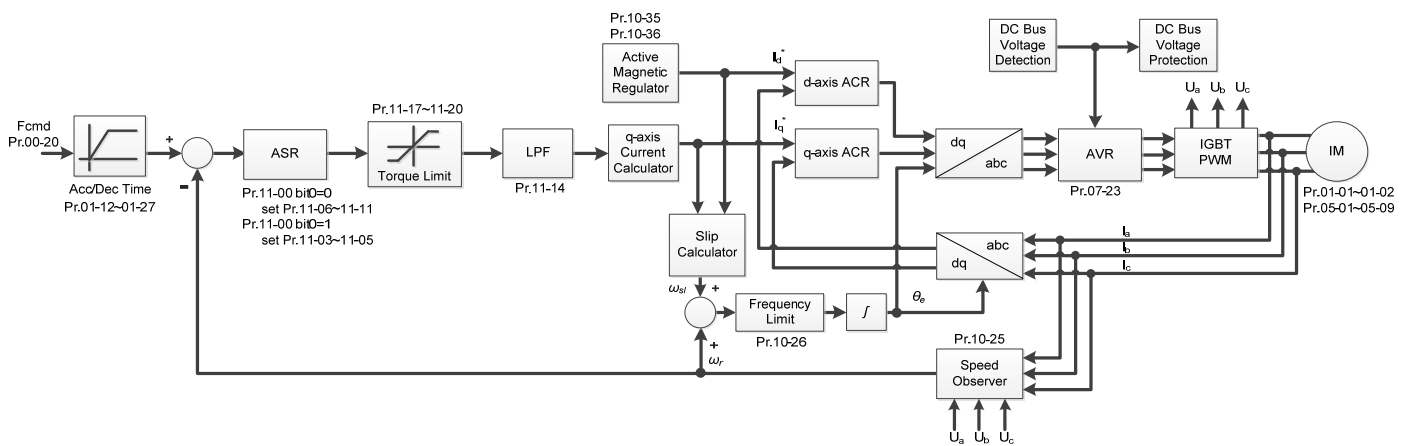

Adjustment procedure

1. Parameter reset to default, **Pr.00-02 = 10 or 9**  
 (To avoid other parameters that are not related affecting the motor controlling)
2. Set up motor parameters according to the nameplate on the motor
  - Pr. 01-01 Output Frequency of Motor 1
  - Pr. 01-02 Output Voltage of Motor 1
  - Pr. 05-01 Full-load Current for Induction Motor 1
  - Pr. 05-02 Rated Power for Induction Motor 1
  - Pr. 05-03 Rated Speed for Induction Motor 1
  - Pr. 05-04 Number of Poles for Induction Motor 1

3. Press "RUN" to start auto-tuning of IM magnetic flux curve dynamic test for Pr.05-00 = 1 or 6 (motor is running). Make sure the motor executes auto-tuning under break-away load condition. Check if there are motor parameters after auto-tuning.

Pr. 05-06 Stator Resistance (Rs) for Induction Motor 1

Pr. 05-07 Rotor Resistance (Rr) for Induction Motor 1

Pr. 05-08 Magnetizing Inductance (Lm) for Induction Motor 1

Pr. 05-09 Stator Inductance (Lx) for Induction Motor 1

4. Execute estimation of the motor inertia (optional). Press "RUN" to start the estimation after finishing the settings for the parameters mentioned below.

Pr. 00-10 = 2, torque mode

Pr. 00-13 = 2, TQC sensorless

Pr. 05-00 = 12, FOC sensorless inertia estimation (motor is running)

After inertia estimation is finished, check if the estimated value for Pr. 11-01 is reasonable, refer to the base value table below. (Unit: kg-cm<sup>2</sup>)

Power	Setting	Power	Setting	Power	Setting
1HP	2.3	25HP	142.8	175HP	2150.0
2HP	4.3	30HP	176.5	250HP	2800.0
3HP	8.3	40HP	202.5	300HP	3550.0
5HP	14.8	50HP	355.5	375HP	5139.0
7.5HP	26.0	60HP	410.8	425HP	5981.0
10HP	35.8	75HP	494.8	475HP	7053.0
12HP	54.8	100HP	1056.5	600HP	9643.0
15HP	74.3	125HP	1275.3	650HP	10734.0
20HP	95.3	150HP	1900.0	750HP	13000.0

5. Execute IM sensorless FOC mode, set up the following parameters:

Pr. 00-10 = 0, set as speed mode

Pr. 00-11 = 5, set as FOC sensorless mode

Pr. 11-00 bit0 =1, use ASR gain auto-tuning

Press "RUN" and start the **Test with no-load**. Accelerate the motor to the rated speed, and then decelerate to stop, check if the motor runs smoothly.

**If the motor runs smoothly, then the setting for IM Sensorless FOC is completed.**

**If the motor does not run smoothly, or fails to start at low-frequency, then refer to the following steps for adjustment.**

6. Select auto-tuning gain (Pr. 11-00 bit0=1), adjust ASR parameters according to the speed response.

Pr. 11-00 bit0 =1, use auto-tuning for ASR

Pr. 11-03 ASR1 low-speed bandwidth (When the acceleration of low-speed cannot follow the acceleration command, increase the low-speed bandwidth)

Pr. 11-04 ASR2 high-speed bandwidth (When the acceleration in high speed causes vibration or cannot follow the acceleration command, increase high-speed bandwidth)

Pr. 11-05 Zero-speed bandwidth (If the response of start-up is slow or incapable, increase zero-speed bandwidth)

The bigger the setting value for ASR bandwidth, the faster the response.

The low-speed bandwidth cannot be set too high, or the observer will diverge.

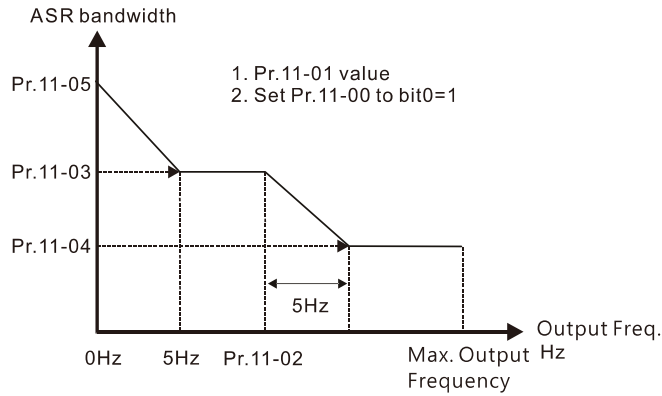

ASR adjustment- auto gain

7. Adjust the setting of FOC speed observer and per-unit value of inertia (common problems)

- Pr. 10-25: Set up FOC bandwidth of speed observer
  - Situation 1. Speed command changes rapidly, but speed response cannot follow.  
(Speed response is too slow→ Increase the setting value)
  - Situation 2. The noise of the observer is too large, and causes the operation diverged.  
(Speed noise is too large→Decrease)
- Pr. 11-01: Set up per unit of system inertia
  - Situation 1. The inrush current is too high at start-up, and causes an oc error.
  - Situation 2. An ocn error occurs during RUN or STOP, and the motor runs randomly.
    - ◆ Check Pr. 11-01 whether the JM per-unit of system inertia is too large.
    - ◆ Decrease Pr. 10-25 FOC bandwidth for speed observer, or Pr. 11-05 zero-speed bandwidth.

8. Related parameters

**00-11** Speed Control Mode

Default: 0

- Settings
- 0: IMVF (IM V/F control)
  - 1: IMVFPG (IM V/F control+ Encoder)
  - 2: IM/PM SVC(IM/PM space vector control)
  - 3: IMFOCPG (IM FOC + Encoder)
  - 4: PMFOCPG (PM FOC + Encoder)
  - 5: IMFOC Sensorless (IM FOC sensorless)
  - 6: PM Sensorless (PM FOC sensorless)
  - 7: IPM Sensorless (Interior PM FOC sensorless)

**01-01** Output Frequency of Motor 1 (Base Frequency and Motor Rated Frequency)

Default: 60.00 / 50.00

Settings 0.00–599.00Hz

📖 Set this value according to the motor’s rated frequency from the motor’s nameplate. If the motor’s rated frequency is 60Hz, set the value to 60Hz. If the motor’s rated frequency is 50Hz, set the value to 50Hz.

**01-02** Output Voltage of Motor 1 (Base Frequency and Motor Rated Frequency)

Default:

200.0/ 400.0/ 575.0/ 660.0

Settings 230V series: 0.0–255.0V  
 460V series: 0.0–510.0V  
 575V series: 0.0–637.0V  
 690V series: 0.0–765.0V

 Set this value according to the motor's rated voltage from the motor's nameplate. If the motor's rated voltage is 220V, set the value to 220.0V. If the motor's rated voltage is 200V, set the value to 200.0V.

 There is a wide variety of motors, but the power system for each country is difference. The convenient and economical way to solve this problem is to use an AC motor drive, which can deal with different voltages and frequencies, while supporting the original characteristic and life of the motor.

**05-00** Motor Parameter Auto-tuning

Default: 0

Settings 0: No function  
 1: Simple rolling auto-tuning for induction motor (IM)  
 2: Static auto-tuning for induction motor (IM)  
 4: Dynamic test for PM magnetic pole (with the running in forward direction)  
 5: Rolling auto-tuning for PM (IPM / SPM)  
 6: Advanced rolling auto-tuning for IM flux curve  
 12: FOC Sensorless inertia estimation  
 13: Static auto-tuning for PM (IPM / SPM)

 **05-02** Rated Power for Induction Motor 1 (kW)

Default: Depending on the model power

Settings 0.00–655.35 kW

 Sets the rated power for motor 1. The default is the drive's power value.

 **05-03** Rated Speed for Induction Motor 1 (rpm)

Default: Depending on the motor pole number

Settings 0–XXXX (Depending on the motor pole number)

 Sets the rated speed for the motor as indicated on the motor nameplate.



 Pr. 01-01 and Pr. 05-04 determine the maximum rotor speed for IM.

For example: Pr. 01-01=20Hz, Pr. 05-04=2, according to the equation  $120 \times 20 \text{ Hz} / 2 = 1200 \text{ rpm}$  and take integers. Due to the slip of the IM, the maximum setting value for Pr. 05-03 is 1199rpm (1200rpm – 1).

**05-04** Number of Poles for Induction Motor 1

Default: 4

Settings 2–64

-  Sets the number poles for the motor (must be an even number).
-  Set up Pr. 01-01 and Pr. 05-03 before setting up Pr. 05-04 to make sure the motor operates normally. Pr. 01-01 and Pr. 05-03 determine the maximum set up number poles for the IM. For example: Pr. 01-01 = 20 Hz and Pr. 05-03 = 39 rpm, according to the equation  $120 \times 20\text{Hz} / 39 \text{ rpm} = 61.5$  and take even number, the number of poles is 60. Therefore, Pr. 05-04 can be set to the maximum of 60 poles.

**05-05** No-load Current for Induction Motor 1 (A)

Default: Depending on the model power

Settings 0 to the factory setting in Pr.05-01

-  For model with 110kW and above, default setting is 20% of motor rated current.

**05-06** Stator Resistance( $R_s$ ) for Induction Motor 1

Default: Depending on the model power

Settings 0.000–65.535 $\Omega$ **05-07** Rotor Resistance( $R_r$ ) for Induction Motor 1

Default: 0.000

Settings 0.000–65.535 $\Omega$ **05-08** Magnetizing Inductance ( $L_m$ ) for Induction Motor 1**05-09** Stator inductance ( $L_x$ ) for Induction Motor 1

Default: 0.0

Settings 0.0–6553.5mH

 **10-25** FOC Bandwidth for Speed Observer

Default:40.0

Settings 20.0–100.0Hz

-  Setting the speed observer to a higher bandwidth could shorten the speed response time, but creates greater noise interference during the speed observation.

**11-00** System Control

Default: 0000h

Settings

- bit0: Auto-tuning for ASR and APR
- bit1: Inertia estimate (only in FOCPG mode)
- bit2: Zero servo
- bit6: 0Hz linear-cross
- bit7: Save or do not save the frequency
- bit8: Maximum speed for point-to-point position control

bit0 = 0: Manual adjustment for ASR and APR gain, Pr. 11-06–Pr. 11-11 are valid and Pr. 11-03–Pr. 11-05 are invalid.

bit0 = 1: Auto-tuning for ASR and APR gain, the system automatically generates an ASR setting, Pr. 11-06–Pr. 11-11 are invalid and Pr. 11-03–Pr. 11-05 are valid.

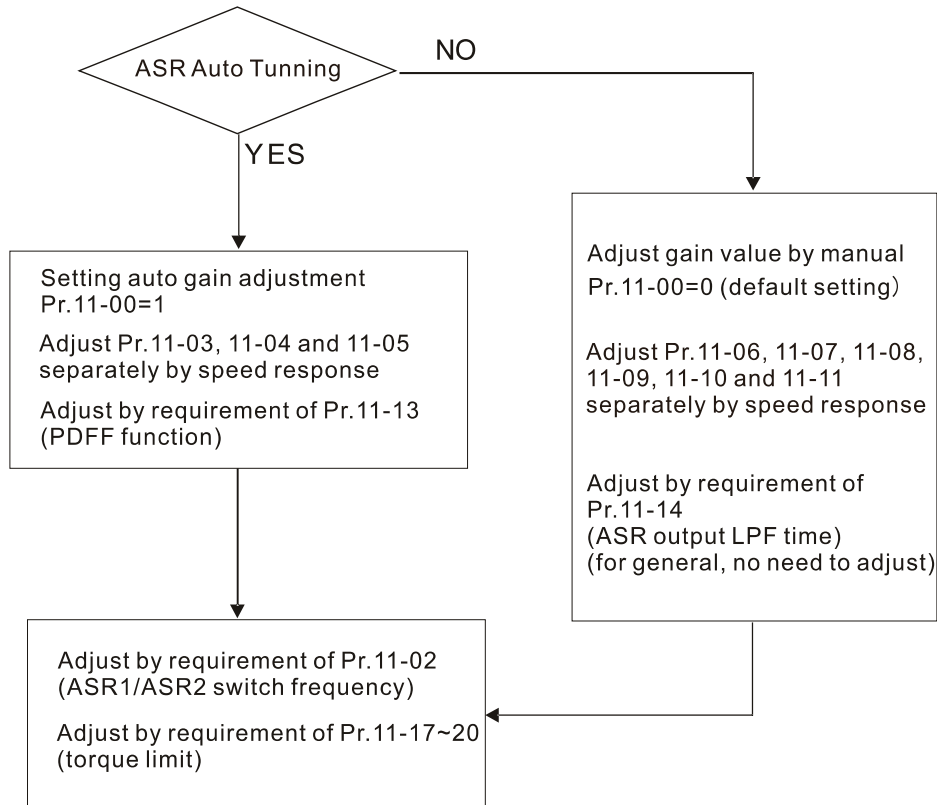

When the drive needs to keep a certain torque at zero-speed, or it needs a steady frequency output at extreme low speed, increase Pr. 11-05 zero-speed bandwidth appropriately. When the speed is in high-speed area, if the output current trembles seriously and makes the drive vibrate, then decrease the high-speed bandwidth.

For example:

Manual gain	Response: [Pr. 11-10, Pr. 11-11] > [Pr. 11-06, Pr. 11-07] > [Pr. 11-08, Pr. 11-09]
Auto gain	Pr. 11-05 = 15 Hz, Pr. 11-03 = 10 Hz, Pr. 11-04 = 8 Hz

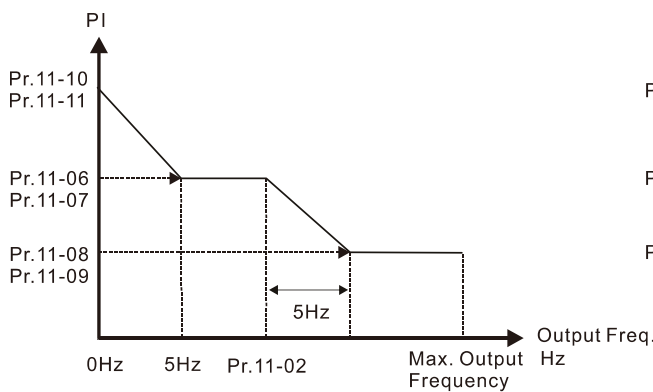

ASR adjustment- manual gain

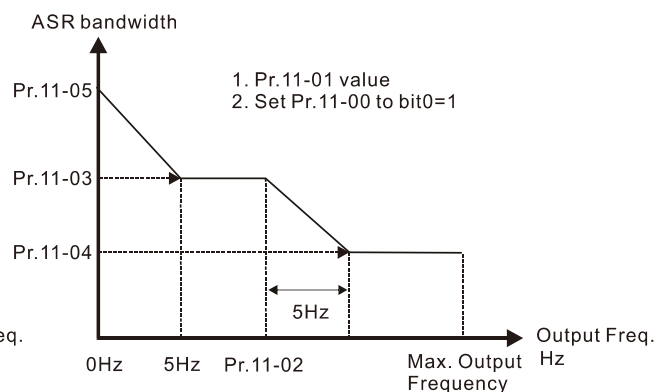

ASR adjustment- auto gain

📖 bit1 = 0: no function.

bit1 = 1: Inertia estimation function is enabled. bit1 setting would not activate the estimation process, set Pr. 05-00 = 12 to begin FOC / TQC Sensorless inertia estimating.

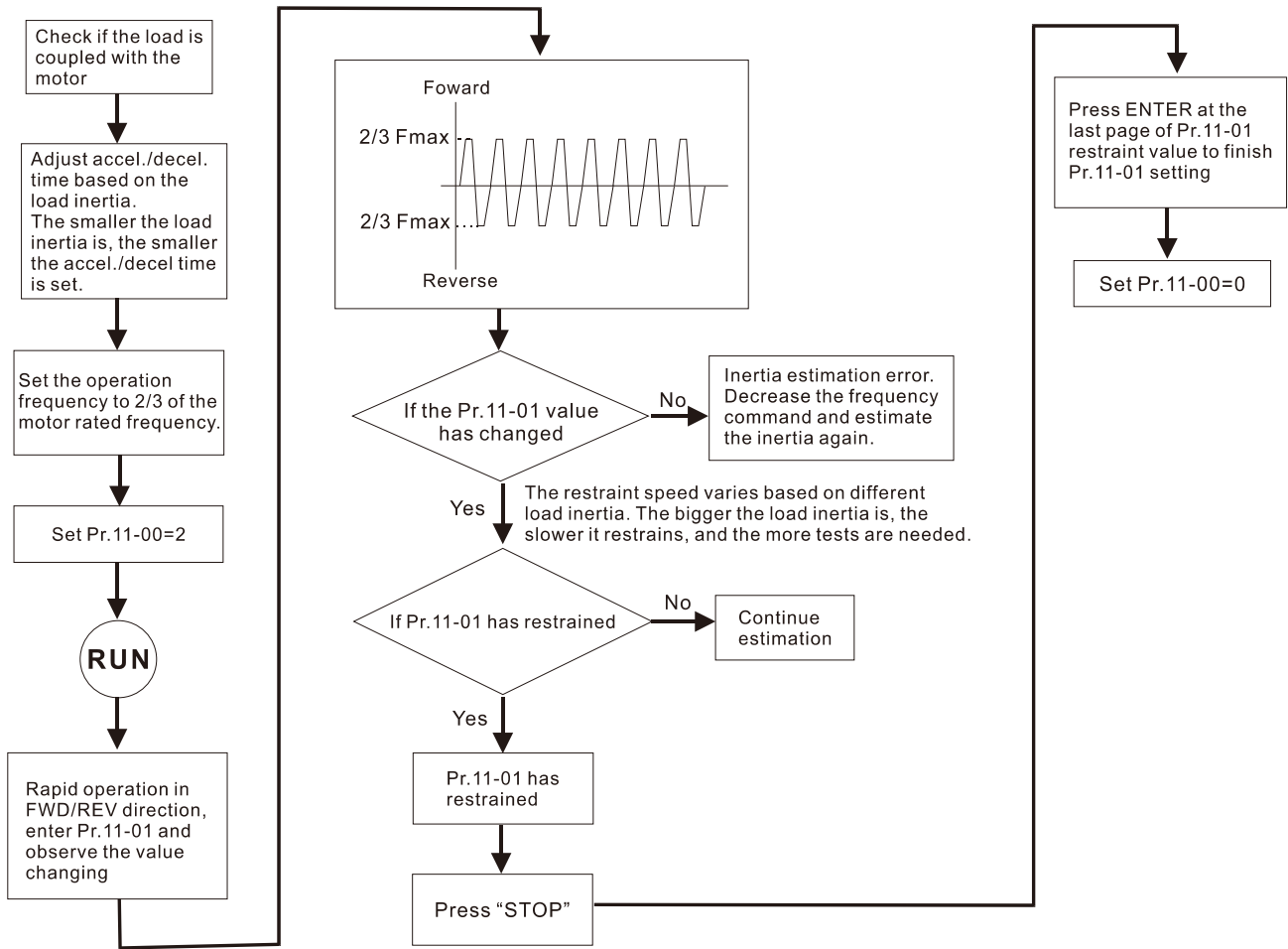

**11-01** Per Unit of System Inertia

Default: 256

Settings 1-65535 (256=1PU)

- 📖 To get the system inertia from Pr.11-01, user needs to set Pr.11-00 to bit1=1 and execute continuous forward / reverse running.
- 📖 When Pr. 11-01 = 256, it is 1PU. So if you use a 2HP motor, the 2HP motor inertia is 4.3 kg-cm<sup>2</sup> according to the table below. If Pr. 11-01 = 10000 after tuning, the system inertia is (10000 / 256) x 4.3 kg-cm<sup>2</sup>.
- 📖 Perform the operation test with load based on the inertia after tuning. Run the motor in acceleration, deceleration, and steady speed and observe the values. If values between speed feedback and speed command are close, steady-state error is small and overshoot is less, then this inertia is a better one.
- 📖 When using torque mode as the control mode, perform the tuning with speed mode first to see if the tuned inertia can work normally. After verifying with speed mode, change the control mode to torque mode.
- 📖 If the Iq current command from ASR has high-frequency glitch, then decrease the setting. If the response time of sudden loading is too slow, then increase the setting.

Unit of induction motor system inertia is kg-cm<sup>2</sup>:

Power	Setting	Power	Setting	Power	Setting
1HP	2.3	25HP	142.8	175HP	2150.0
2HP	4.3	30HP	176.5	250HP	2800.0
3HP	8.3	40HP	202.5	300HP	3550.0
5HP	14.8	50HP	355.5	375HP	5139.0
7.5HP	26.0	60HP	410.8	425HP	5981.0
10HP	35.8	75HP	494.8	475HP	7053.0
12HP	54.8	100HP	1056.5	600HP	9643.0
15HP	74.3	125HP	1275.3	650HP	10734.0
20HP	95.3	150HP	1900.0	750HP	13000.0

The base value for PM system inertia is set by Pr.05-38 and the unit is in kg-cm<sup>2</sup>.

### 11-02 ASR1 / ASR2 Switch Frequency

Default: 7.00

Settings 5.00–599.00Hz

 Sets the low-speed and high-speed ASR switching point in the FOC area. Provides flexibility to meet two needs: in the high-speed region of the estimator switch point it has a high response, and in the low-speed region of the estimator switch point it has a lower response. The recommended switching point is higher than Pr. 10-39.

 A low setting does not cover Pr. 10-39. If the setting is too high, the high-speed range is too narrow.

### 11-03 ASR1 Low-speed Bandwidth

Default: 10

Settings 1–40Hz (IM) / 1–100Hz (PM)

### 11-04 ASR2 High-speed Bandwidth

Default: 10

Settings 1–40Hz (IM) / 1–100Hz (PM)

### 11-05 Zero-speed Bandwidth

Default: 10

Settings 1–40Hz (IM) / 1–100Hz (PM)

 After estimating inertia and setting Pr.11-00 bit0=1 (auto-tuning), you can adjust Pr.11-03, Pr. 11-04 and Pr. 11-05 separately according to the speed response. The larger the setting value, the faster response you. Pr. 11-02 is the switch frequency for the low-speed / high-speed bandwidth.

 The position control pulse command (Mlx=37) and P2P position control Kp gain can adjust Pr. 11-05. The higher the value, the lower the steady-state error.



12-2-2 Standard PM Motor Adjustment Procedure

12-2-2-1 Pr.00-11=4 PM FOC+PG

1. Control Diagram

(A) PM FOC+PG Control Diagram (applicable for C2000 V2.04 and above)

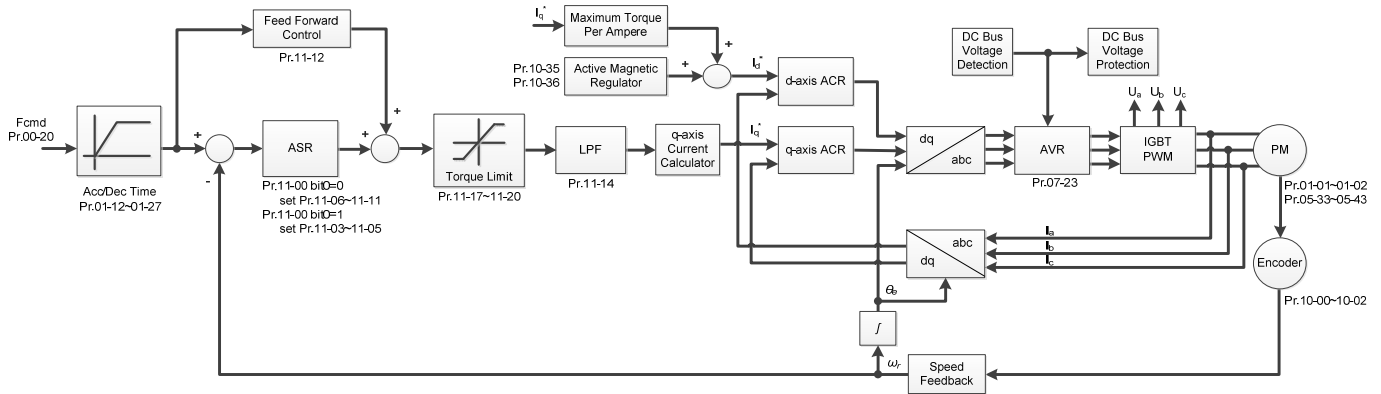

(B) PM TQC+PG Control Diagram (applicable for C2000 V2.04 and above)

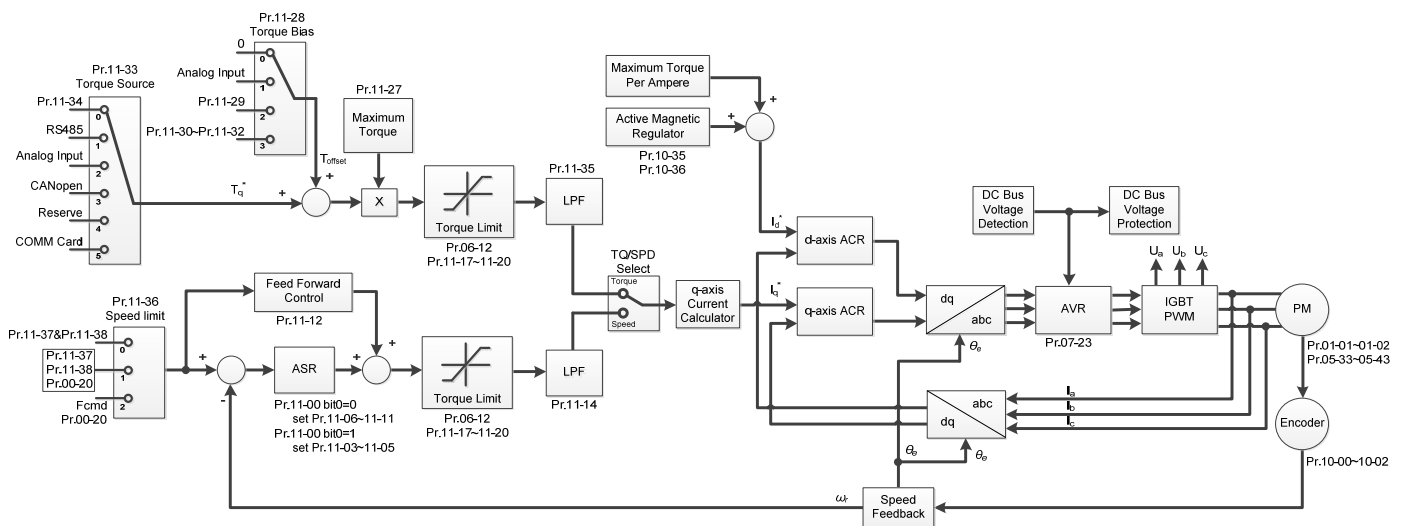

2. PM FOC+PG Adjustment Procedure (\* the number marked on the procedure corresponds to the number of following adjustment explanations)

 PM FOC+PG Motor Parameter Adjustment Procedure

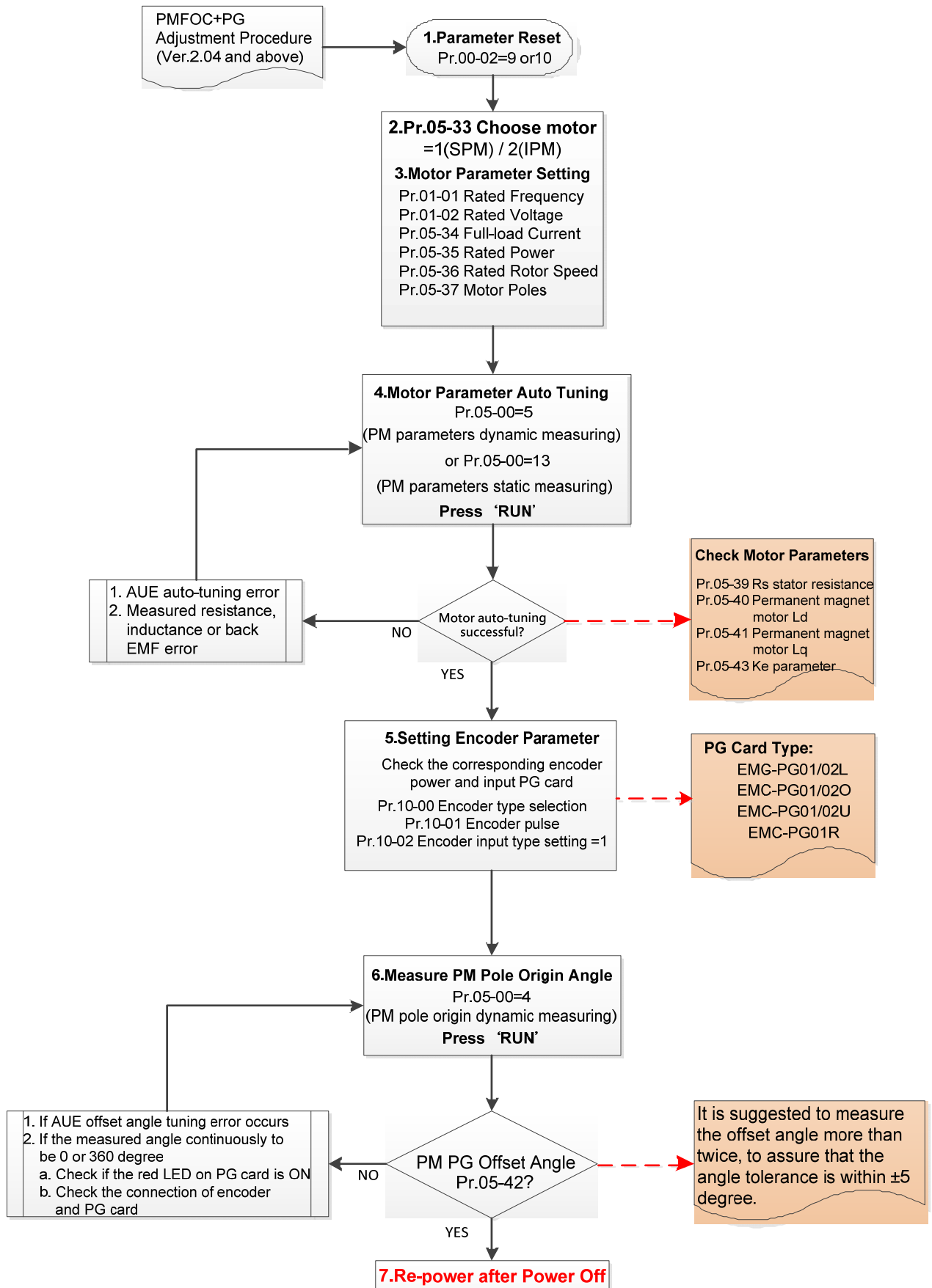

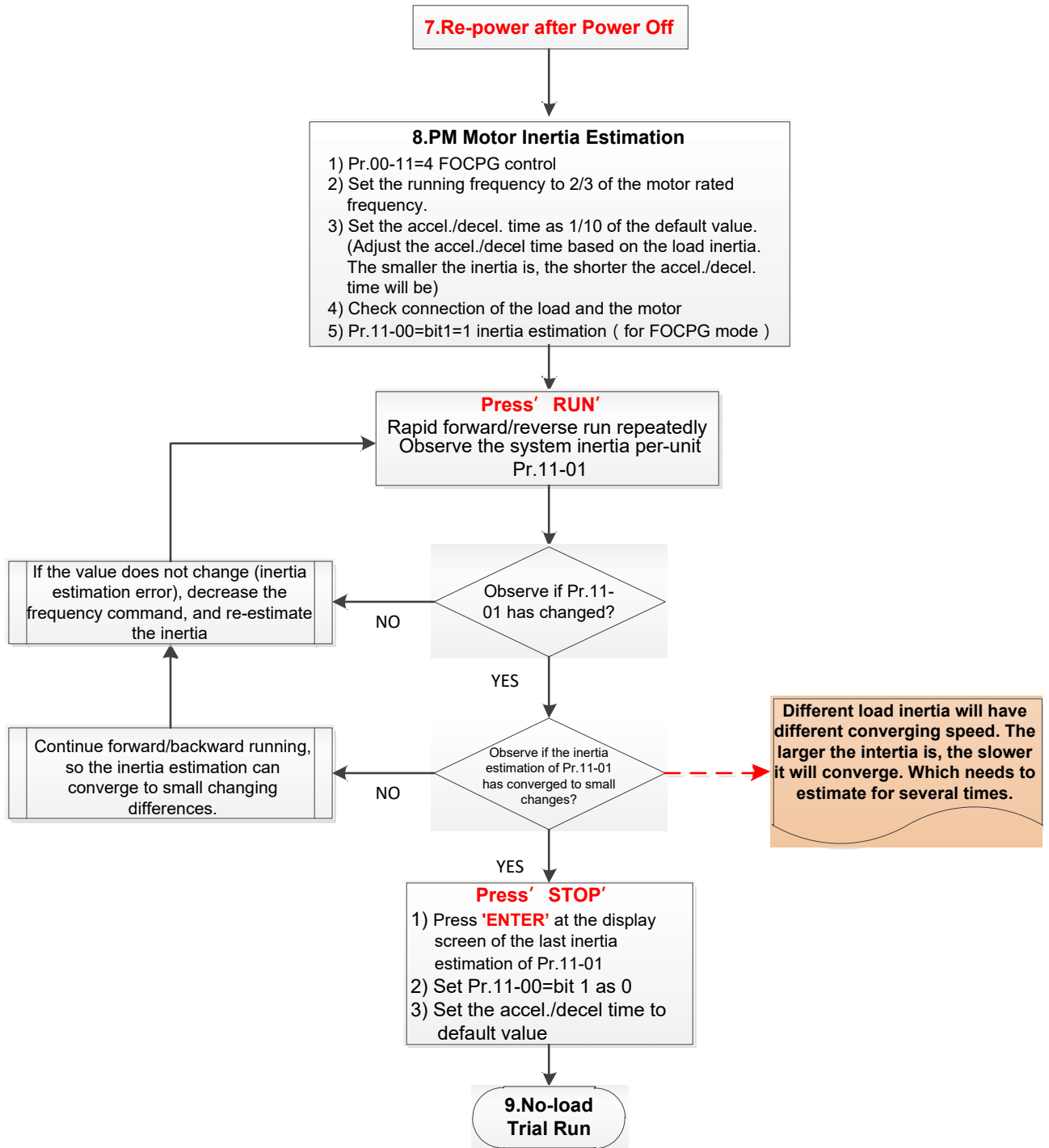

Basic Motor Parameters Adjustment

1. Parameter reset:  
Pr.00-02=9 (50Hz) or 10 (60Hz), reset parameter to the default value.
2. Select IPM motor type:  
Pr.05-33=1 (SPM) or 2 (IPM)
3. Motor nameplate parameter setting:

Parameter	Description
Pr.01-01	Rated frequency (Hz)
Pr.01-02	Rated voltage (V <sub>AC</sub> )
Pr.05-33	PM motor type (IPM or SPM)
Pr.05-34	Rated current (A)

Parameter	Description
Pr.05-35	Rated power (kW)
Pr.05-36	Rated rotor speed (RPM)
Pr.05-37	Number of poles for the motor (poles)

#### 4. PM parameter auto-tuning:

Rolling auto-tuning for PM (without load) Pr.05-00=5 or static auto-tuning for PM (Pr.05-00=13)

Set Pr.05-00=5 or 13 and press “RUN” key to finish motor auto-tuning, then you will get the following parameters:

Parameter	Description
Pr.05-39	Stator resistance for a permanent magnet motor ( $\Omega$ )
Pr.05-40	Permanent magnet motor Ld (mH)
Pr.05-41	Permanent magnet motor Lq (mH)
Pr.05-43	Ke parameter of a permanent magnet motor ( $V_{\text{phase}} \cdot \text{rms} / \text{krpm}$ ) (When Pr.05-00=5, the Ke parameter is measured based on the actual motor rotation.) (When Pr.05-00=13, the Ke parameter is automatically calculated based on the motor power, current and rotor speed.)

If an auto-tuning error (AUE) occurs, refer to Section 14 “Error Codes and Descriptions” for further treatment.

AUE Error (code)	Description
AUE (40)	Auto-tuning error
AUE1 (142)	Auto-tuning error 1 (No feedback current error)
AUE2 (143)	Auto-tuning error 2 (Motor phase loss error)
AUE3 (144)	Auto-tuning error 3 (No-load current $I_0$ measuring error)
AUE4 (148)	Auto-tuning error 4 (Leakage inductance $L_{\text{sigma}}$ measuring error)

#### 5. Set encoder parameter

Check the encoder power and input type, make sure it is used with correct PG card.

PG Card Type			
EMC-PG01L	EMC-PG01O	EMC-PG01U	EMC-PG01R
EMC-PG02L	EMC-PG02O	EMC-PG02U	-

Related parameters:

- (1) Pr. 10-00: Encoder type selection
- (2) Pr. 10-01: Encoder pulses per revolution
- (3) Pr. 10-02: Encoder input type setting = 1 (Phases A and B are pulse inputs, forward direction if A-phase leads B-phase by 90 degrees)

#### 6. Measure the initial magnetic pole angle of PM

- (1) Set Pr.05-00=4 (dynamic test for PM magnetic pole)
- (2) Press “RUN” key to proceed the PM magnetic pole measurement, and to get the offset angle.

Note 1: It is suggested to measure the offset angle more than twice, to make sure the angle tolerance is within  $\pm 5$  degree.

Note 2: Verify the encoder and PG card are connected in the right order.

7. Cycle the power.
8. Execute inertia estimation for PM
  - (1) Set Pr. 00-11 = 4 FOCPG control.
  - (2) Set the operation frequency command to 2/3 of the motor's rated frequency.
  - (3) Set the acceleration / deceleration time (Pr. 01-12, Pr. 01-13) to 1/10 of the default time.  
(Adjust the acceleration / deceleration time according to the load inertia. The smaller the load inertia, the shorter the acceleration / deceleration time is set).
  - (4) Check if the load and the motor is connected.
  - (5) Set Pr. 11-00 bit1 = 1 inertia estimate (only in FOCPG mode).
  - (6) Press "RUN" key to proceed the inertia  
Quickly run the motor in forward and reverse direction repeatedly, and observe the inertia estimated value of Pr. 11-01 for the keypad.
    - a. If the system inertial estimated value of Pr. 11-01 does not change ( = default 256), it means the inertia estimation is wrong. Reduce the frequency command and estimate the inertia again.
    - b. If the system inertia estimated value of Pr. 11-01 is still a lot different from the estimated value of FWD/REV operation, continue the estimation in forward / reverse operating direction to restraint the estimated inertia to small difference.
  - (7) Press "STOP" key to obtain the estimated inertia value:
    - a. Press "ENTER" to confirm the input value at the displayed page of the last estimated inertia value of Pr. 11-01.
    - b. Set Pr.11-01 bit1 = 0, return the control mode to speed mode.
    - c. Set the acceleration / deceleration time (Pr. 01-12, Pr. 01-13) back to the default value.

II. PM FOC+PG No-load/ Light-load Adjustment Procedure

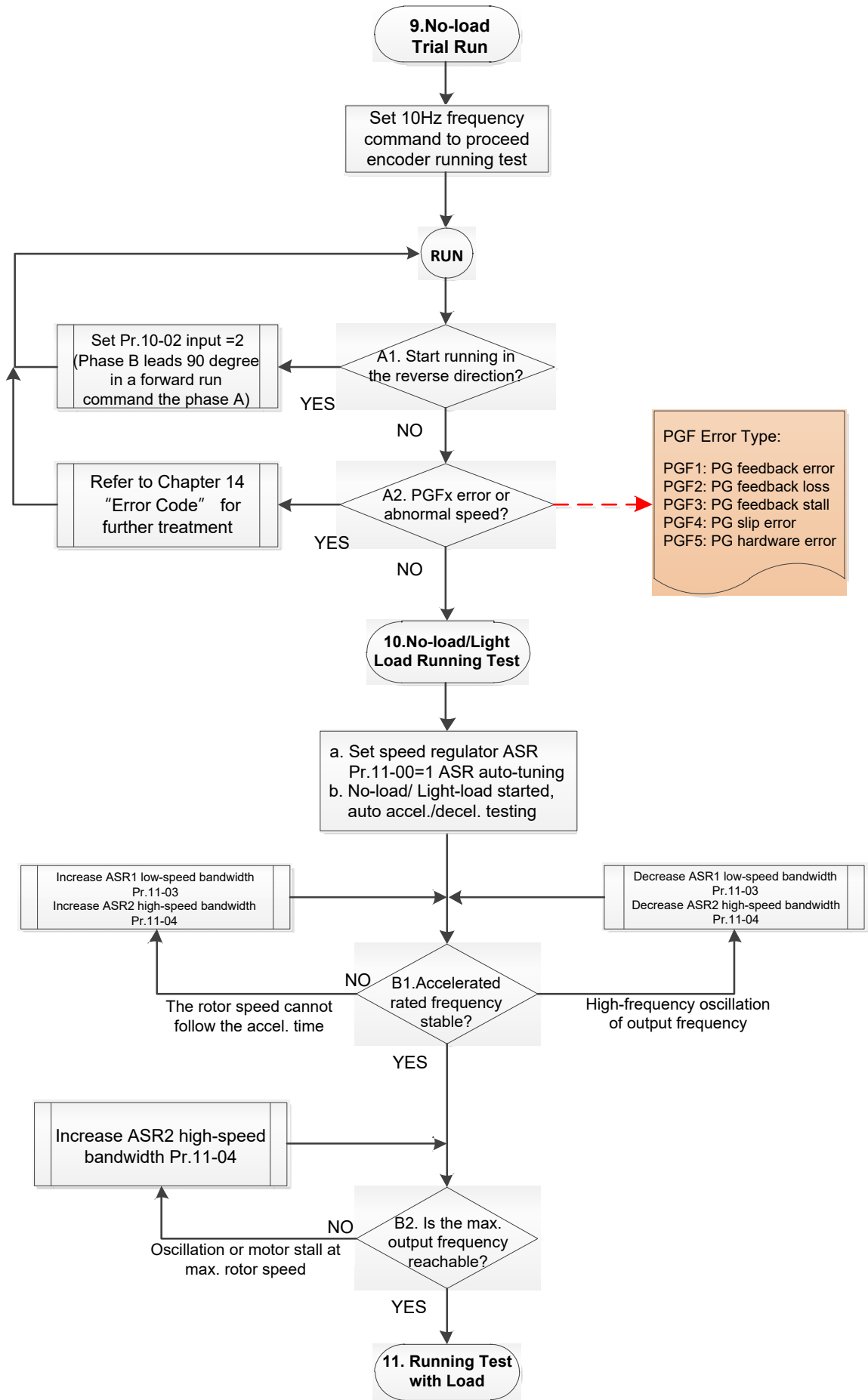

📖 No-load/ Light duty Running Adjustment

9. No-load trial run

Set the frequency command to 10Hz to proceed the encoder running test:

A1. If the motor starts in a reverse direction.

If the motor starts in a reverse direction, set the encoder input type Pr. 10-02 = 2 (phases A and B are pulse inputs, forward direction if B-phase leads A-phase by 90 degrees.)

A2. Observe if a PGFx error is displayed on the keypad, or the motor runs in an abnormal speed.

If the PGFx error is displayed or the motor runs in an abnormal speed, refer to Section 14 “Fault Codes and Descriptions” or the following table for PGFx error type and further treatment.

PGF Error (code)	Description	Solution
PGF1 (42)	PG feedback error	Check parameter setting of Pr.10-00–10-02
PGF2 (43)	PG feedback loss	Check the wiring of encoder and PG card
PGF3 (44)	PG feedback stall	Check the wiring of encoder and PG card
PGF4 (45)	PG slip error	Check the pulse setting of Pr.10-01 Check the wiring of encoder and PG card
PGF5 (65)	PG hardware error	Check if the PG card is installed on the correct slot position Check the setting parameter of the encoder

10. No-load / light duty running test

- a. Set the speed regulator (ASR) as Pr.11-00=1, and set the ASR gain as auto-tuning.
- b. Start the motor with no-load / light duty and proceed acceleration / deceleration test.

B1. Accelerate to the rated frequency and observe if the motor runs stably.

- If the output rotor speed cannot follow the acceleration time, increase Pr.11-04 (ASR2 high-speed bandwidth) or Pr.11-03 (ASR1 low-speed bandwidth).
- If a high-frequency oscillation occurs in the output frequency, decrease Pr.11-04 (ASR2 high-speed bandwidth) or Pr.11-03 (ASR1 low-speed bandwidth).

B2. Accelerate the motor to the maximum frequency and observe if it runs stably.

If an oscillation occurs or motor stalls at maximum rotor speed during operation, increase Pr.11-04 (ASR2 high-speed bandwidth) or Pr.00-17 (Carrier frequency).

Setting curve of speed regulator (ASR) and related parameter:

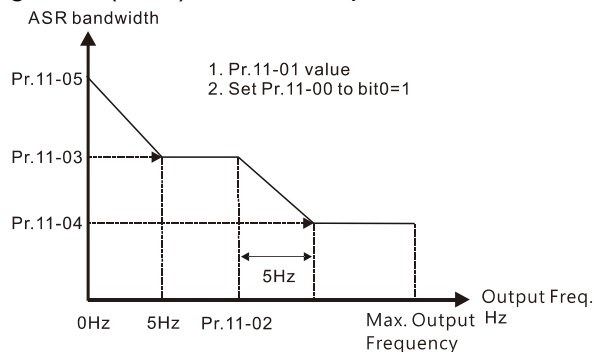

ASR adjustment- auto gain

Parameter	Description	Default
Pr.11-00	System control	0
Pr.11-01	Per unit of system inertia	256
Pr.11-02	ASR1/ASR2 switch frequency (it is suggested to set the switch frequency higher than Pr.10-39)	7Hz
Pr.11-03	ASR1 low-speed bandwidth	10Hz
Pr.11-04	ASR2 high-speed bandwidth	10Hz
Pr.11-05	ASR zero-speed bandwidth	10Hz

 PM FOC+PG With-load starting adjustment procedure

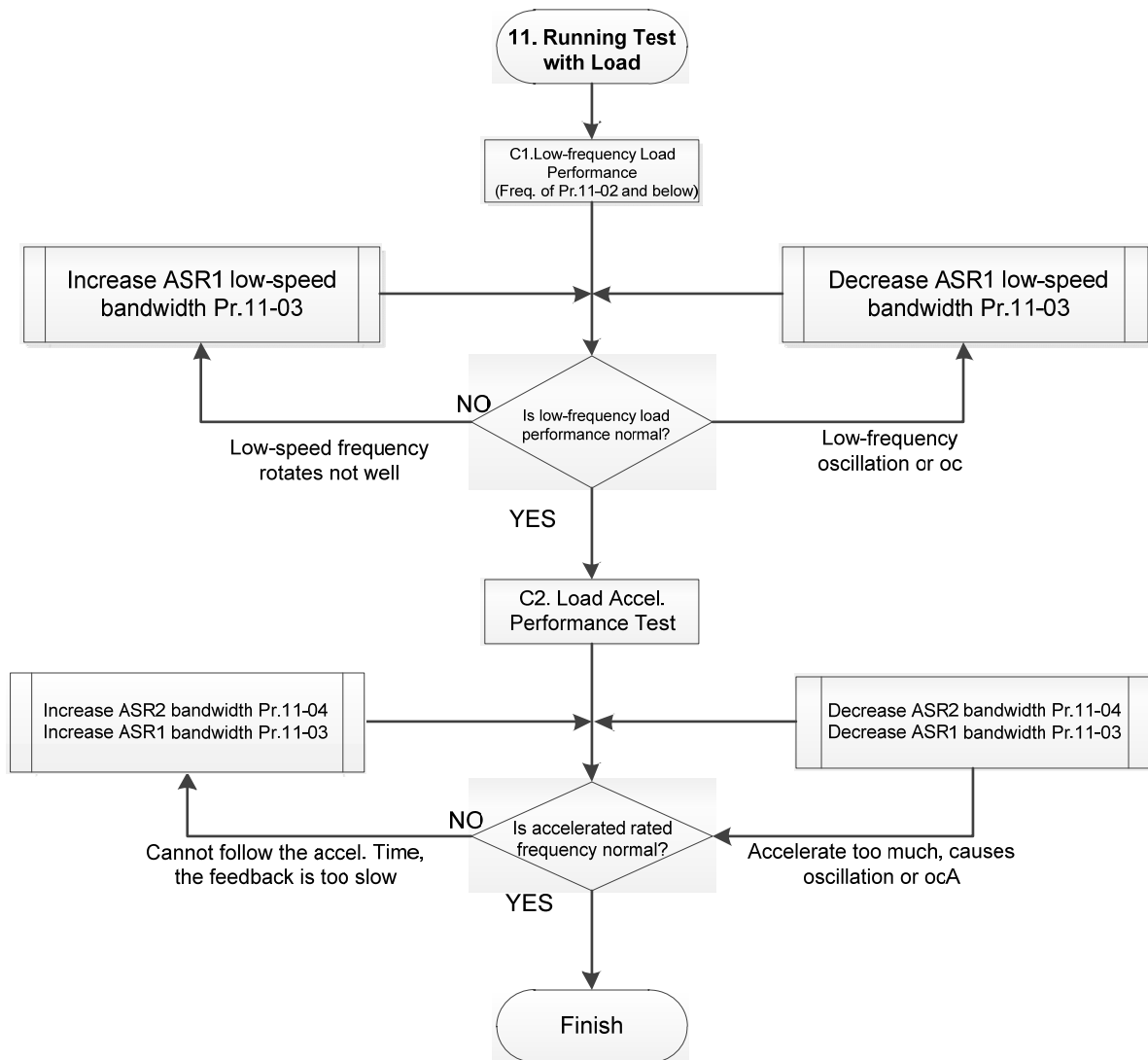

 With-load Operation Adjustment:

C1. Low-frequency load performance, when the drive operates under ASR1/ASR2 switch frequency (Pr.11-02):

- If the low-speed frequency cannot start-up with load or the rotor speed is not smooth, increase Pr.11-03 (ASR1 low-speed bandwidth), or increase Pr.11-01 (Per-unit system inertia).
- If an oscillation or over current (oc) error occurs at low-speed frequency, decrease Pr.11- (ASR1 low-speed bandwidth) or decrease Pr.11-01 (Per-unit system inertia).



- C2. With-load accelerating performance testing in heavy-load status, accelerate the motor to the rated rotor speed according to the acceleration time.
- a. If the motor rotor speed cannot follow the acceleration time, and the response is too slow, increase Pr.11-04 (ASR2 high-speed bandwidth) and Pr.11-03 (ASR1 low-speed bandwidth); if the response speed is still not enough, increase 10% of the per-unit system inertia for Pr.11-01 each time.
  - b. If an excessive acceleration causes an oscillation or ocA error, decrease Pr.11-04 (ASR2 high-speed bandwidth) and Pr.11-03 (ASR1 low-speed bandwidth).

12-2-2-2 PM FOC+PG Adjustment Parameters

Refer to Section 12-1 “Description of Parameter Settings” for detailed information.

Parameter	Description	Unit	Default	Setting Range
<b>Encoder Setting Parameters</b>				
Pr.10-00	Encoder type selection	N/A	0	0–5
Pr.10-01	Encoder pulses per revolution	ppr	600	1–20000
Pr.10-02	Encoder input type setting	N/A	0	0–5
<b>Motor Performance Control Parameters</b>				
Pr.11-00	System control	bit	0	0–8
Pr.11-01	Per-unit of system inertia	N/A	256	1–65535
Pr.11-02	ASR1 / ASR2 switch frequency	Hz	7	5.00–599
Pr.11-03	ASR1 low-speed bandwidth	Hz	10	1–100 (PM) 1–40 (IM)
Pr.11-04	ASR2 high-speed bandwidth	Hz	10	1–100 (PM) 1–40 (IM)
Pr.11-05	Zero-speed bandwidth	Hz	10	1–100 (PM) 1–40 (iM)

12-2-3 PM Motor Adjustment (PM SVC)

12-2-3-1 Permanent magnet motor space vector control (PM SVC) Pr. 00-11 = 2

1. Control Diagram

PM SVC control diagram (applicable for C2000 V2.04 and above)

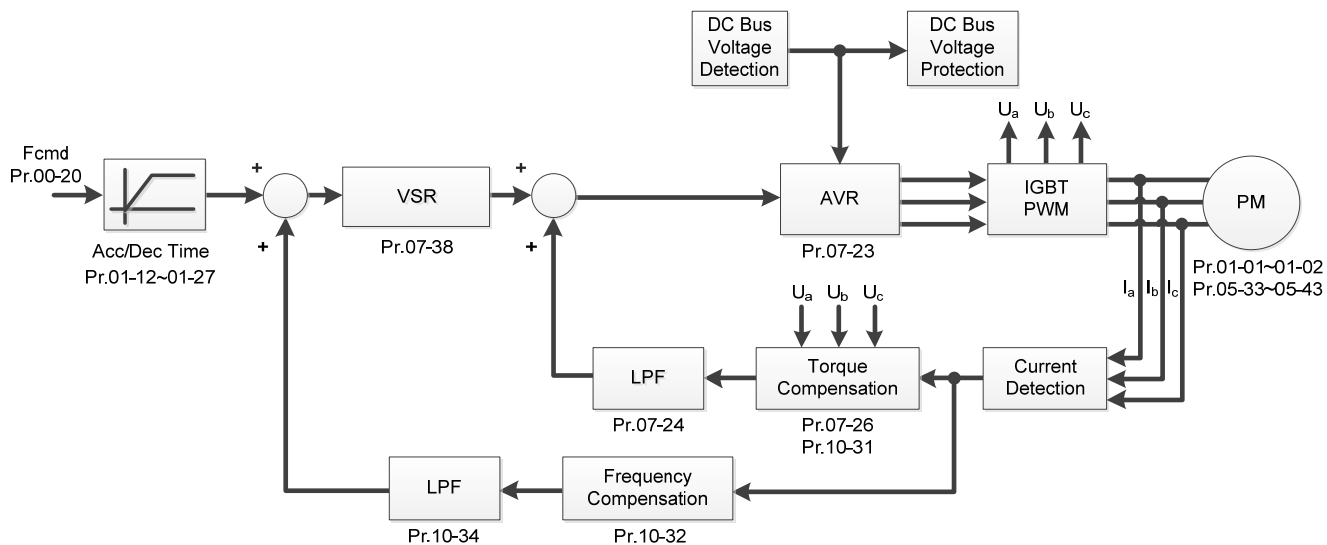

2. PM SVC Adjustment Procedure (\* the number marked on the procedure corresponds to the number of following adjustment explanations)

I. PM SVC motor parameters adjustment

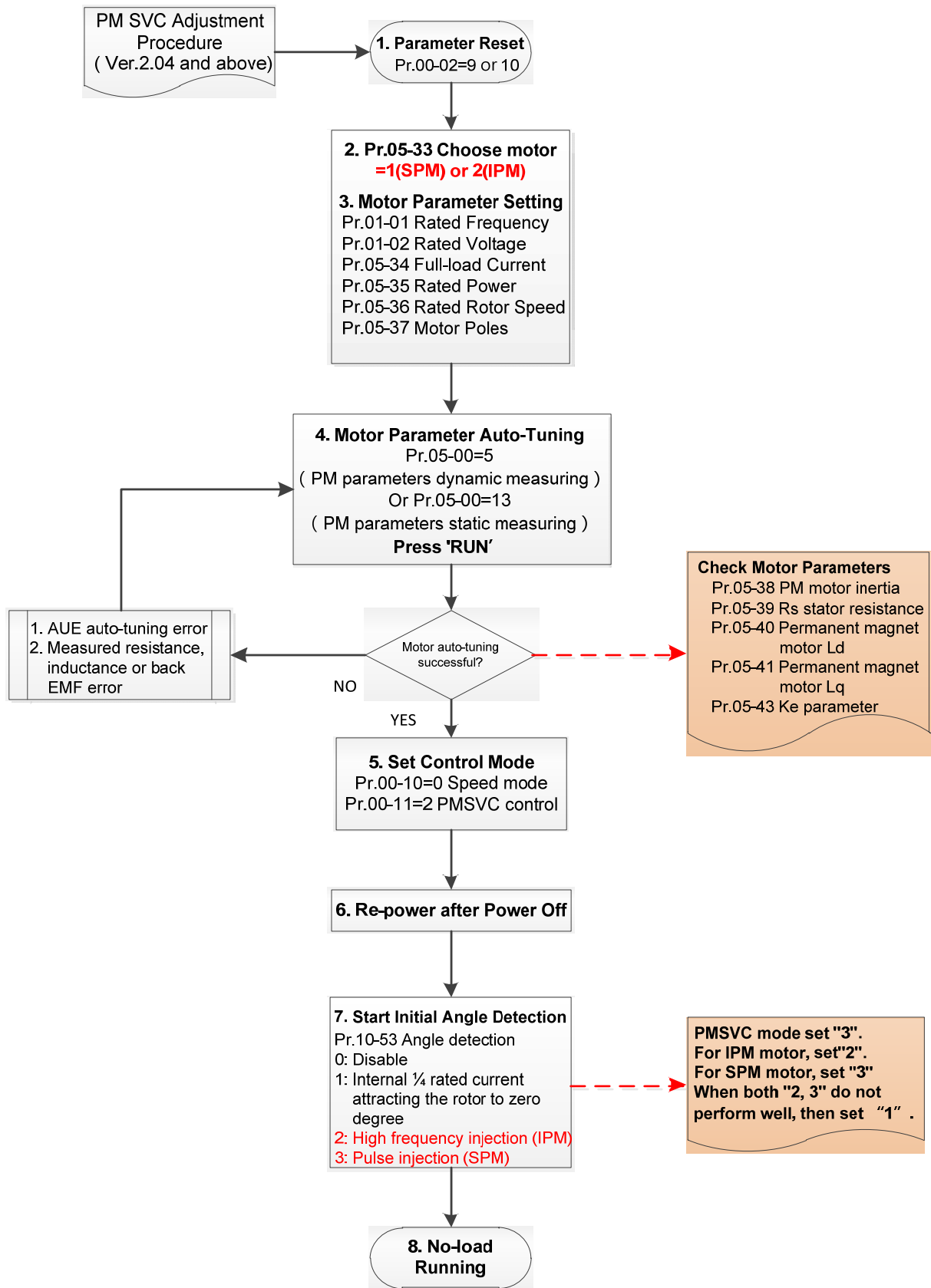

## Basic Motor Parameters Adjustment

### 1. Parameter reset:

Pr.00-02=9 (50Hz) or 10 (60Hz), reset parameter to the default value.

### 2. Select PM motor type:

Pr.05-33=1 (SPM) or 2 (IPM)

### 3. Motor nameplate parameter setting:

Parameter	Description
Pr.01-01	Rated frequency (Hz)
Pr.01-02	Rated voltage ( $V_{AC}$ )
Pr.05-33	PM motor type (IPM or SPM)
Pr.05-34	Rated current (A)
Pr.05-35	Rated power (kW)
Pr.05-36	Rated rotor speed (RPM)
Pr.05-37	Number of poles for the motor (poles)

### 4. PM parameter auto-tuning:

Rolling auto-tuning for PM (without load) Pr.05-00=5 or static auto-tuning for PM (Pr.05-00=13)

Set Pr.05-00=5 or 13 and press "RUN" key to finish motor auto-tuning, then you will get the following parameters:

Parameter	Description
Pr.05-38	System inertia for a permanent magnet motor ( $\text{kg}\cdot\text{cm}^2$ )
Pr.05-39	Stator resistance for a permanent magnet motor ( $\Omega$ )
Pr.05-40	Permanent magnet motor $L_d$ (mH)
Pr.05-41	Permanent magnet motor $L_q$ (mH)
Pr.05-43	Ke parameter of a permanent magnet motor ( $V_{\text{phase}} \cdot \text{rms} / \text{krpm}$ ) (When Pr.05-00=5, the Ke parameter is measured based on the actual motor rotation.) (When Pr.05-00=13, the Ke parameter is automatically calculated based on the motor power, current and rotor speed.)

If an auto-tuning error (AUE) occurs, refer to Section 14 "Error Codes and Descriptions" for further treatment.

AUE Error (code)	Description
AUE (40)	Auto-tuning error
AUE1 (142)	Auto-tuning error 1 (No feedback current error)
AUE2 (143)	Auto-tuning error 2 (Motor phase loss error)
AUE3 (144)	Auto-tuning error 3 (No-load current $I_0$ measuring error)
AUE4 (148)	Auto-tuning error 4 (Leakage inductance $L_{\text{sigma}}$ measuring error)

### 5. Set control mode

Control mode for the drive: Pr. 00-10 = 0: Speed mode

Control mode for the motor: Pr. 00-11 = 2: PM SVC mode

### 6. After setting the control mode, cycle the power.

7. Measure the initial magnetic pole angle of PM

Set Pr.10-53 PM initial rotor position detection method

0: Disable

1: Internal 1/4 rated current attracting the rotor to zero degrees

2: High frequency injection

3: Pulse injection

(Set to 2 for IPM; set to 3 for SPM. If these settings cause problems, then set the parameter to 1.)

II. PMSVC Adjustment for Operation without Load / with Light duty

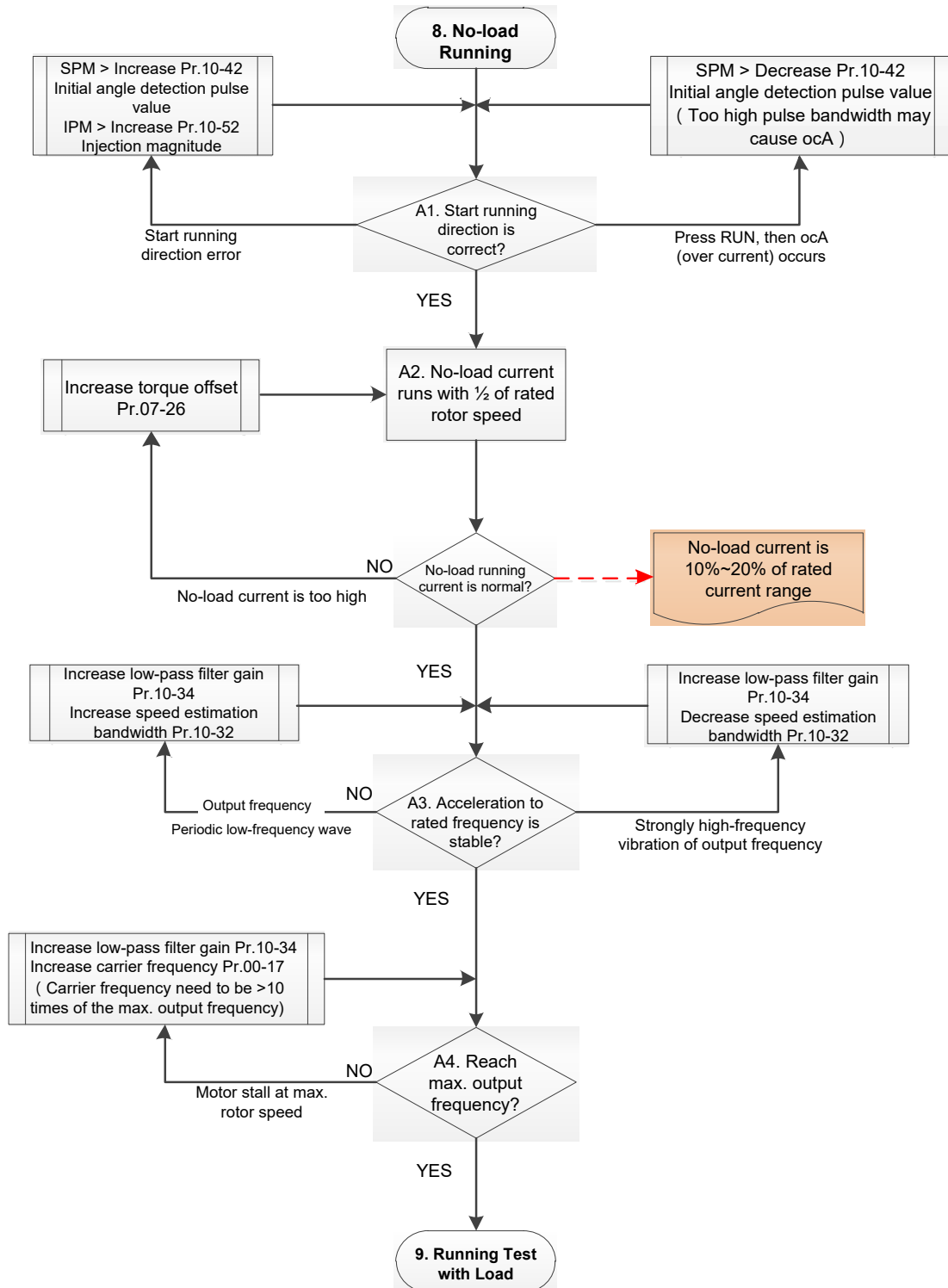

 Adjustment for Operation with Light duty

8. Start the motor with no-duty / light-duty, and operates to 1/2 of the rated rotor speed

A1. Start operation direction:

a. If the start operation direction is wrong

SPM: increase the current proportion for Pr. 10-42 (Initial angle detection pulse value) to improve the accuracy of the angle detection.

IPM: Increase the voltage for Pr. 10-52 (Injection magnitude) to improve the accuracy of the angle detection.

b. If an ocA error occurs when pressing RUN to start the motor, decrease the current proportion for Pr. 10-42 (Initial angle detection pulse value). An excessive pulse current may cause ocA error easily.

A2. Operates the motor in 1/2 of the rated rotor speed, adjust the no-load operating current

If the no-load operating current exceeds 20% of the rated current, increase Pr. 07-26 (Torque compensation gain) and observe the no-load operating current.

A3. Accelerate to rated frequency and observe if the motor operates stably.

a. If the motor output rotor speed presents periodic low-frequency wave, increase Pr. 10-34 (PM sensorless speed estimator low-pass filter gain), or increase Pr. 10-32 (PM FOC sensorless speed estimator bandwidth).

b. If the output frequency reflects high-frequency vibration, decrease Pr. 10-34 or decrease Pr. 10-32.

A4. Accelerate the motor to the maximum rotor speed, and observe if it operates stably.

If the motor stalls when accelerating to the maximum rotor speed, then increase Pr. 10-34 PM Sensorless Speed Estimator Low-pass Filter Gain, or increase Pr. 00-17 Carrier Frequency (you must set the carrier frequency larger than 10 times of the maximum output frequency)

III. PM SVC Carrier Start-up Adjustment

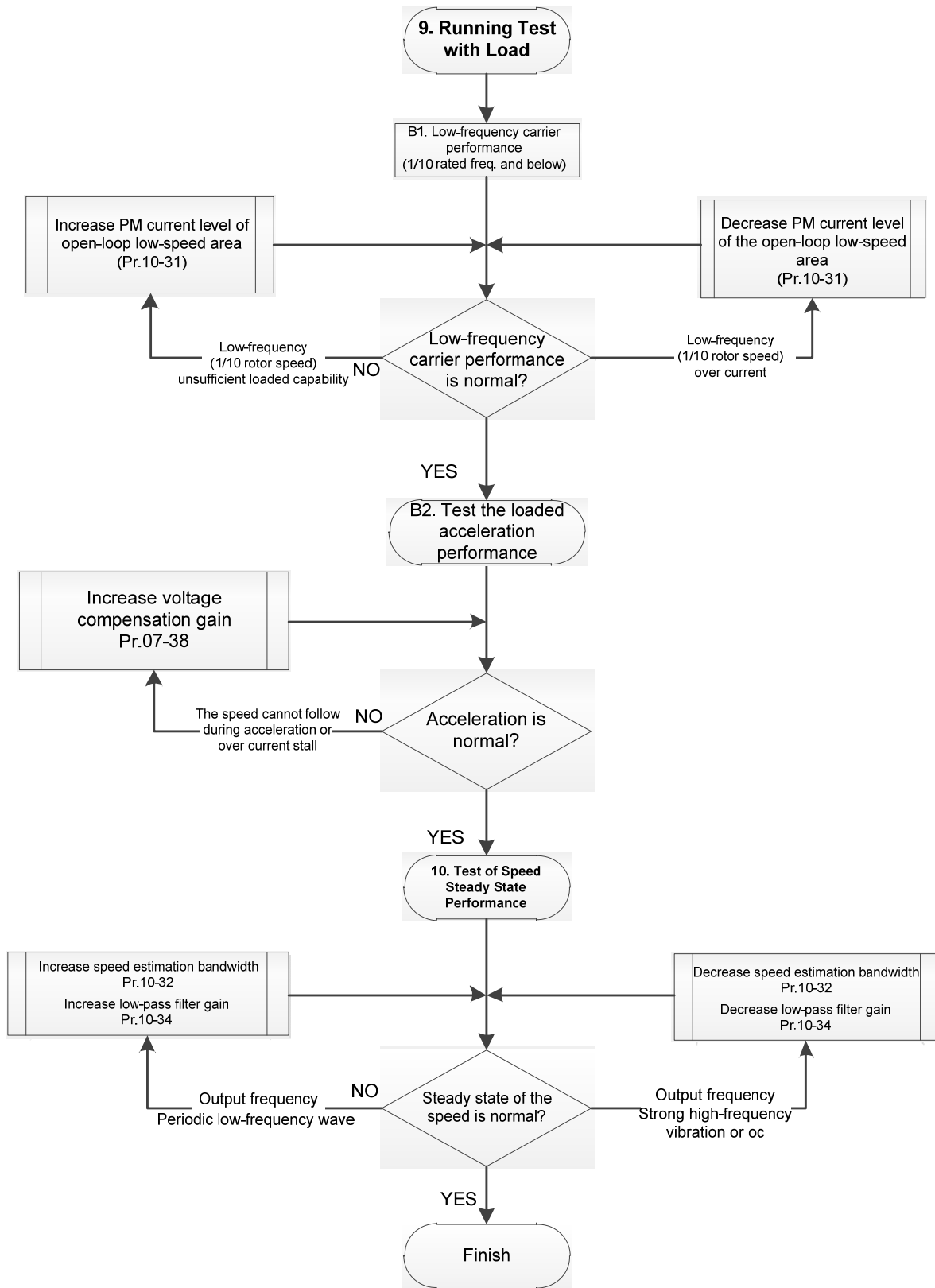

 Heavy Load Operation Adjustment

## 9. Load operating test

B1. Low-frequency loading performance is below 1/10 of rated frequency:

- a. If the low-frequency loading performance is insufficient, or the rotor speed is not smooth, increase Pr. 10-31 (Current command of I/F mode).
- b. If the low-frequency current is large, decrease Pr. 10-31 (Current command of I/F mode).

B2. Test the with-load accelerating performance:

When the motor operates in 1/10 of rotor speed and above, if the speed cannot follow the acceleration time during accelerating, or the current stalls, increase Pr. 07-38 (PMSVC voltage feedback forward gain).

10. Stability test at constant speed operation: if the motor operates stably at constant speed

- a. If the motor output rotor speed presents periodic low-frequency wave, increase Pr. 10-34 (PM sensorless speed estimator low-pass filter gain), or increase Pr. 10-32 (PM FOC sensorless speed estimator bandwidth).
- b. If the output frequency reflects high-frequency vibration, decrease Pr. 10-34 or decrease Pr. 10-32.

## 12-2-3-2 PMSVC Related Parameters

Refer to Section 12-1 Description of Parameter Settings for more details.

Parameter	Description	Unit	Default	Setting Range
Pr.07-24	Torque command filter time	sec.	0.5	0.001–10
Pr.07-26	Torque compensation gain	N/A	0	0–5000
Pr.07-38	PMSVC voltage feedback forward gain	N/A	1.0	0.5–2.0
Pr.10-31	I/F mode, current command	%	40	0–150
Pr.10-32	PM FOC sensorless speed estimator bandwidth	Hz	5.00	0.00–600
Pr.10-34	PM sensorless speed estimator low-pass filter gain	N/A	1.00	0.00–655.35
Pr.10-39	Frequency point to switch from I/F mode to PM sensorless mode	Hz	20.00	0.00–599.00
Pr.10-40	Frequency point to switch from PM sensorless mode to V/F mode	Hz	20.00	0.00–599.00
Initial Angle Estimating Parameters				
Pr.10-42	Initial angle detection pulse value	N/A	1.0	0.0–3.0
Pr.10-51	Injection frequency	Hz	500	0–1200
Pr.10-52	Injection magnitude	V	15.0 / 30.0	0.0–200.0
Pr.10-53	PM initial rotor position detection method 0: Disable 1: Internal 1/4 rated current attracting the rotor to zero degrees 2: High frequency injection 3: Pulse injection	N/A	0	0–3



## 12-2-4 IPM Adjustment

### 12-2-4-1 Pr.00-11=7 Interior PM FOC sensorless vector control (IPM sensorless)

#### 1. Control Diagram

IPM sensorless FOC mode (applicable for C2000 V2.04 and above)

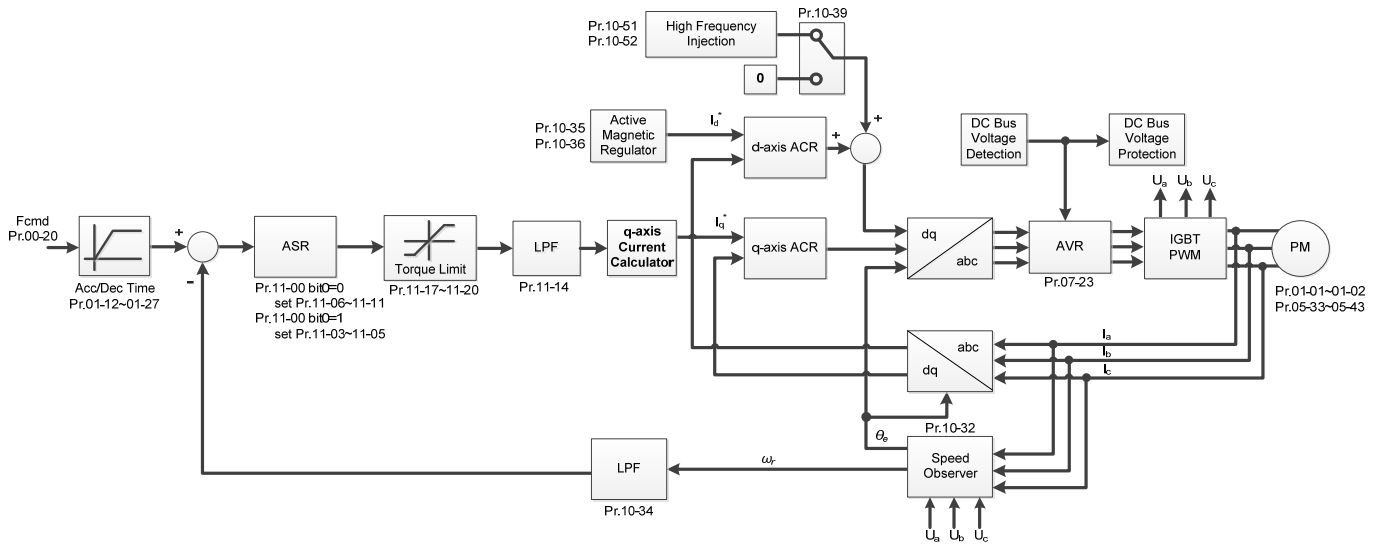

- ※ PM Sensorless FOC control is the control method dedicated for IPM, it uses the high salient pole characteristic ( $L_q > L_d$ ) of IPM to detect the positions of NS magnetic poles. By doing this, it calculates the motor's rotor position at low-speed frequency.

2. IPM Sensorless FOC Control Adjustment Procedure (\* the number marked on the procedure corresponds the number of following adjustment explanations)

I. IPM Sensorless FOC Mode Motor Parameters Adjustment

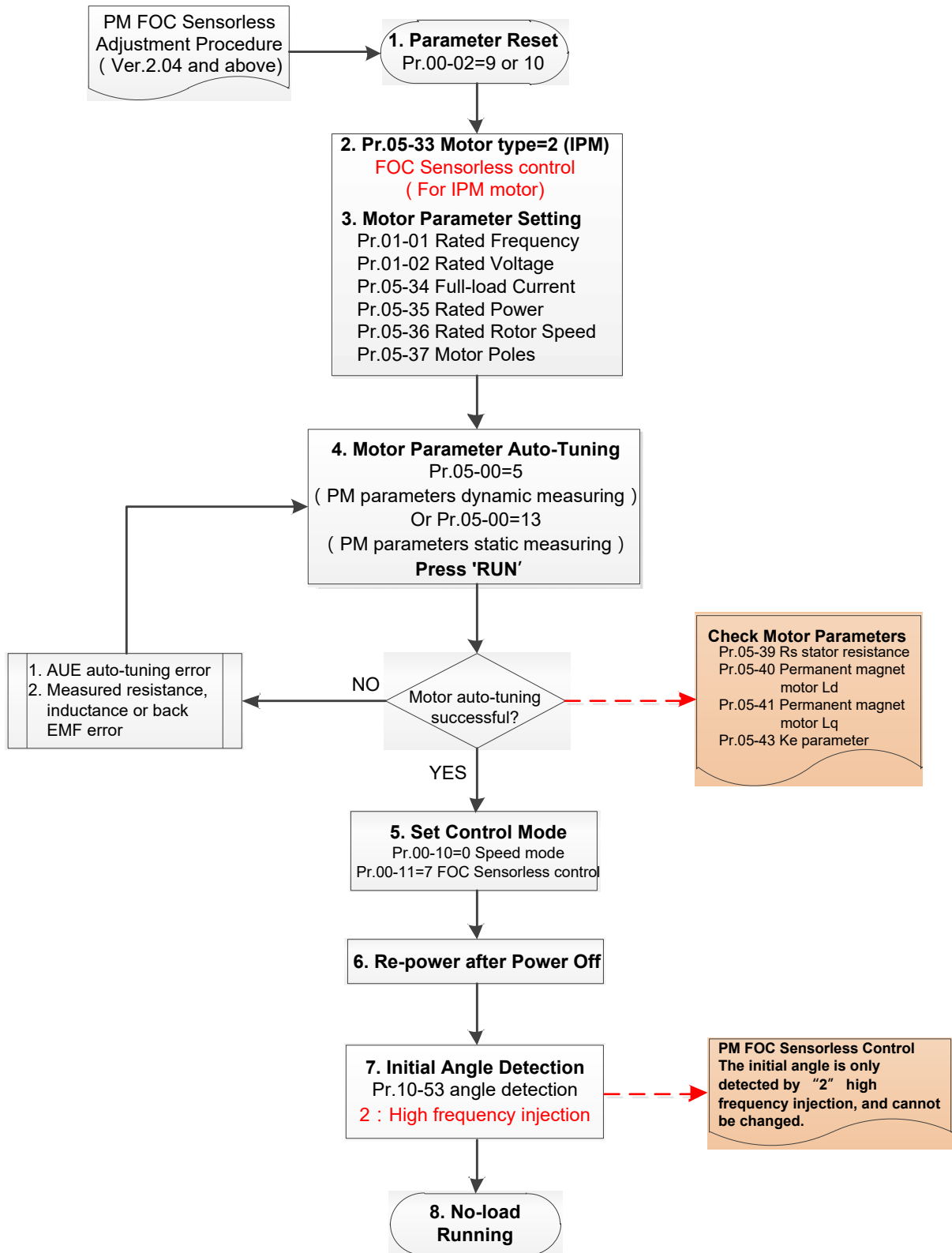

 Basic Motor Parameters Adjustment

1. Parameter reset:  
Pr.00-02=9 (50Hz) or 10 (60Hz), reset parameter to the default value.
2. Select IPM motor type:  
Pr.05-33=2 (IPM)

3. Motor nameplate parameter setting:

Parameter	Description
Pr.01-01	Rated frequency (Hz)
Pr.01-02	Rated voltage (V <sub>AC</sub> )
Pr.05-33	PM motor type (IPM or SPM)
Pr.05-34	Rated current (A)
Pr.05-35	Rated power (kW)
Pr.05-36	Rated rotor speed (RPM)
Pr.05-37	Number of poles for the motor (poles)

4. PM parameter auto-tuning:

Rolling auto-tuning for PM (without load) Pr.05-00=5 or static auto-tuning for PM (Pr.05-00=13)

Set Pr.05-00=5 or 13 and press “RUN” key to finish motor auto-tuning, then you will get the following parameters:

Parameter	Description
Pr.05-39	Stator resistance for a permanent magnet motor ( $\Omega$ )
Pr.05-40	Permanent magnet motor Ld (mH)
Pr.05-41	Permanent magnet motor Lq (mH)
Pr.05-43	Ke parameter of a permanent magnet motor ( $V_{\text{phase}} \cdot \text{rms} / \text{krpm}$ ) (When Pr.05-00=5, the Ke parameter is measured based on the actual motor rotation.) (When Pr.05-00=13, the Ke parameter is automatically calculated based on the motor power, current and rotor speed.)

If an auto-tuning error (AUE) occurs, refer to Section 14 “Error Codes and Descriptions” for further treatment.

AUE Error (code)	Description
AUE (40)	Auto-tuning error
AUE1 (142)	Auto-tuning error 1 (No feedback current error)
AUE2 (143)	Auto-tuning error 2 (Motor phase loss error)
AUE3 (144)	Auto-tuning error 3 (No-load current $I_0$ measuring error)
AUE4 (148)	Auto-tuning error 4 (Leakage inductance $L_{\text{sigma}}$ measuring error)

5. Set control mode

Control mode for the drive: Pr. 00-10 = 0: Speed mode

Control mode for the motor: Pr. 00-11 = 7: Interior PM FOC Sensorless

6. After auto-tuning, cycle the power.
7. Measure the initial magnetic pole angle of PM  
When Pr.00-11=7 PM FOC Sensoreless mode, the initial magnetic pole angle detection method is high frequency injection.

II. IPM Sensorless FOC Mode – No-load / Light-duty Adjustment

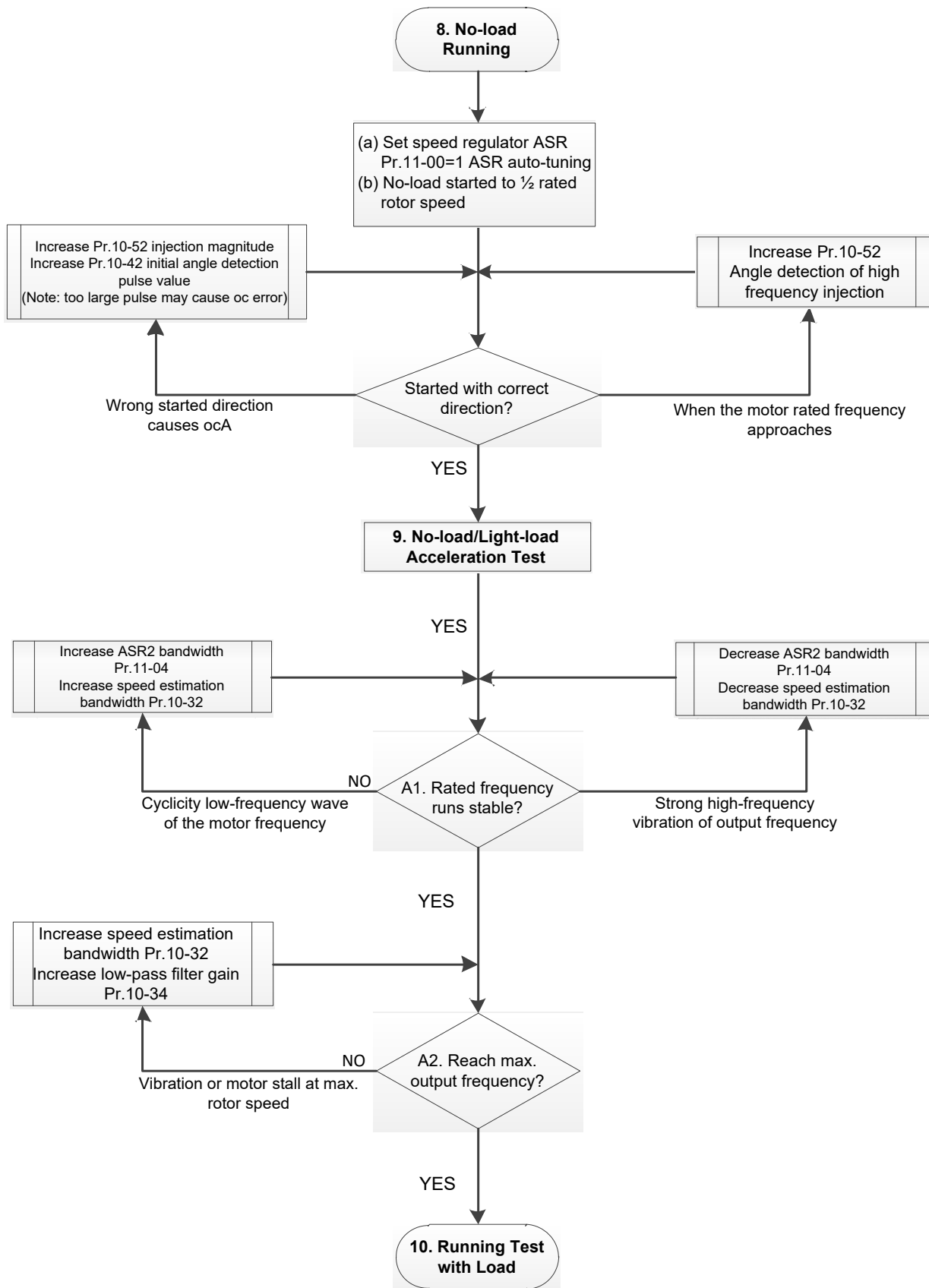

 No-load / Light-duty Operation Adjustment

8. Start the motor with no-duty

(a) Set Pr.11-00 = 1 Auto-tuning for ASR and APR

(b) Start the motor without load, and operates the motor to 1/2 of rated rotor speed

- a. If the start direction is wrong, starting rotation is not smooth (ocA) or the motor salient ratio (Lq / Ld) is low, increase Pr. 10-52 (Injection Magnitude) and Pr. 10-42 (Initial Angel Detection Pulse Value) to improve the accuracy of the angle detection.
- b. If Pr. 10-51 (Injection frequency) is close to the rated motor frequency (Pr. 01-01), then increase Pr.10-51 to avoid the angle detection difference caused by motor rated frequency.

9. Acceleration test with no-duty / light-duty

A1. Accelerate to rated frequency and observe if the motor operates stably.

- a. If the motor output rotor speed presents periodic low-frequency wave, increase Pr. 11-04 (ASR2 high-speed bandwidth), or increase Pr. 10-32 (PM FOC sensorless speed estimator bandwidth).
- b. If the output frequency reflects high-frequency vibration, decrease Pr.11-04 or decrease Pr.10-32.

A2. Accelerate the motor to the maximum frequency, and observe if it operates stably.

If the motor stalls when accelerating to the maximum rotor speed, increase Pr.10-32 (PM FOC sensoress speed estimator bandwidth) and Pr.10-34 (PM sensorless speed estimator low-pass filter gain).

※ Setting curve of speed regulator (ASR) and related parameters:

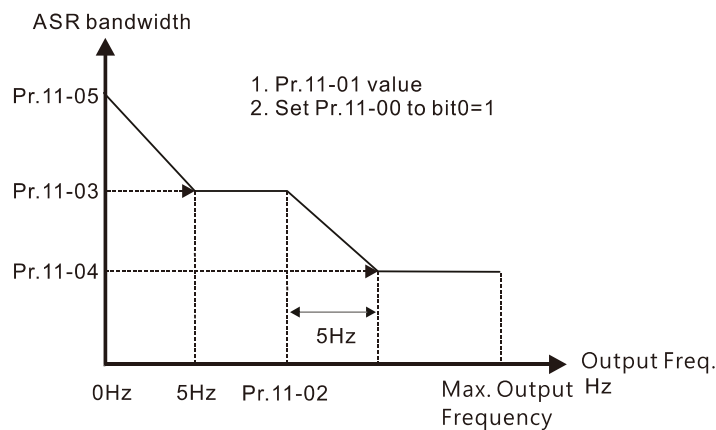

ASR adjustment- auto gain

Parameter	Description	Default
Pr.11-00	System control	0
Pr.11-01	Per unit of system inertia	256
Pr.11-02	ASR1 / ASR2 switch frequency (it is suggested to set the switch frequency higher than Pr.10-39)	7Hz
Pr.11-03	ASR1 low-speed bandwidth	10Hz
Pr.11-04	ASR2 high-speed bandwidth	10Hz
Pr.11-05	Zero-speed bandwidth	10Hz

III. IPM Sensorless FOC Mode – Load Starting Adjustment

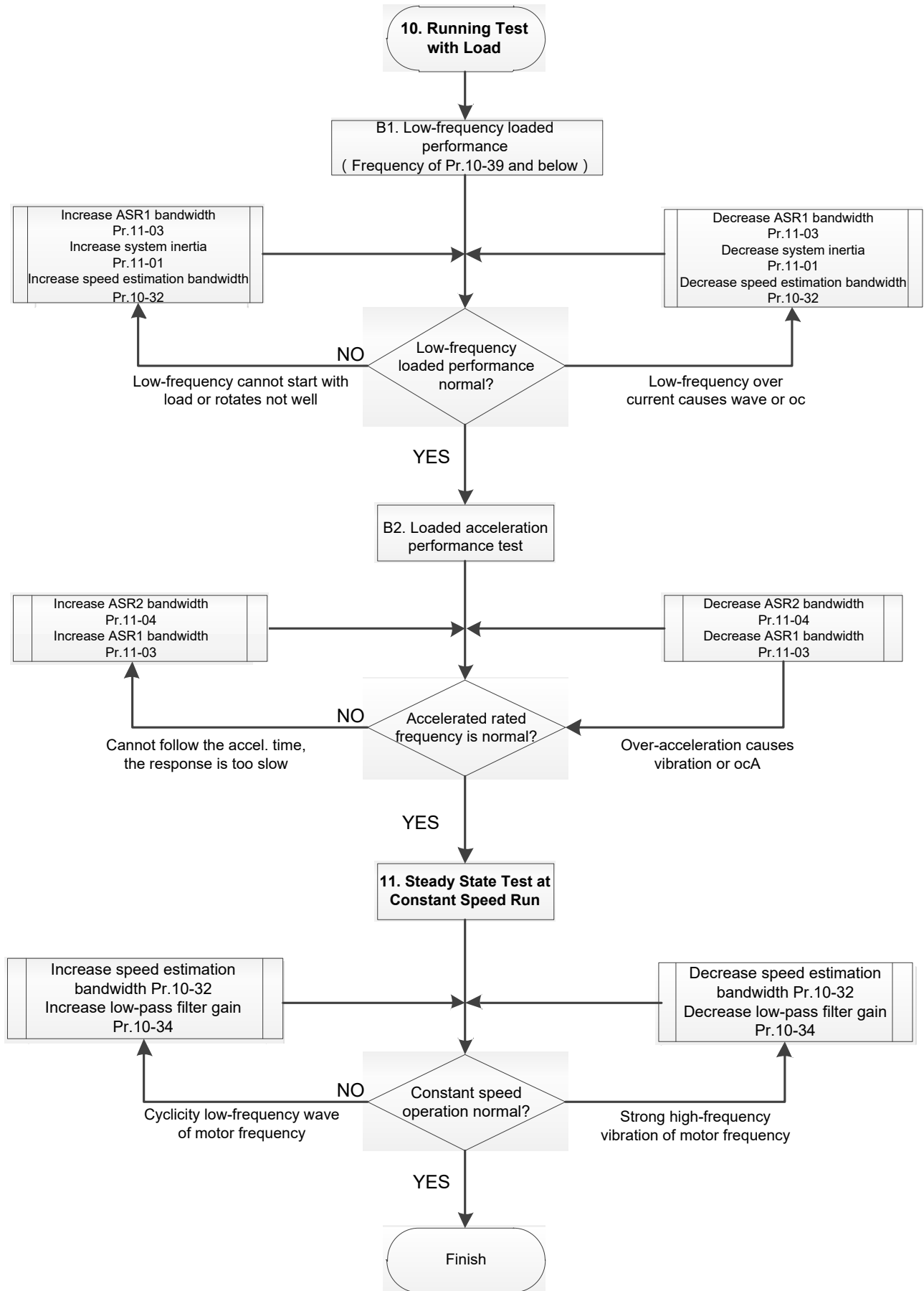

 Load Operation Adjustment

## 10. Load operating test

B1. Low-frequency loading performance, when the switch frequency is below Pr.10-39:

- a. When the low-frequency cannot start the motor with load, or the rotor speed is not smooth, increase Pr.11-03 (ASR1 low-speed bandwidth) or Pr.11-01 (Per-unit of system inertia); if the above adjustment cannot meet the requirement, then increase Pr.10-32 (PM FOC sensorless speed estimator bandwidth).
- b. When frequency outputs, low-frequency operating current is large or an oc error occurs, decrease Pr.11-03 and Pr.11-01; or decrease Pr.10-32.

B2. Acceleration performance test under heavy-duty status, accelerate the motor to rated rotor speed according to the acceleration time:

- a. If the motor cannot follow the acceleration time, and the response is too slow, increase Pr.11-04 (ASR2 high-speed bandwidth) and Pr.11-03 (ASR1 low-speed bandwidth).
- b. If an excessive acceleration causes vibration or ocA error, decrease Pr.11-04 and Pr.11-03.

11. Stability test at constant speed operation: if the motor operates stably at constant speed

- a. If the motor output rotor speed presents periodic low-frequency wave, increase Pr. 10-34 (PM sensorless speed estimator low-pass filter gain), or increase Pr. 10-32 (PM FOC sensorless speed estimator bandwidth).
- b. If the output frequency reflects high-frequency vibration, decrease Pr. 10-34 or decrease Pr. 10-32.

## 12-2-4-2 IPM sensorless FOC Mode Related Parameters:

Refer to Section 12-1 Description of Parameter Settings for more details.

Parameter	Description	Unit	Default	Setting Range
Pr.10-32	PM FOC sensorless speed estimator bandwidth	Hz	5.00	0.00–600
Pr.10-34	PM sensorless speed estimator bandwidth	N/A	1.00	0.00–655.35
Pr.10-35	AMR (Kp) gain	N/A	1.00	0.00–3.00
Pr.10-36	AMR (Ki) gain	N/A	0.20	0.00–3.00
Pr.10-39	Frequency point to switch from I/F mode to PM sensorless mode	Hz	20.00	0.00–599
Pr.10-40	Frequency point to switch from PM sensorless mode to V/F mode	Hz	20.00	0.00–599
Pr.10-42	Initial angle detection pulse value	N/A	1.0	0.0–3.0
Initial Angle Estimating Parameters				
Pr.10-51	Injection frequency (for IPM)	Hz	500	0–1200
Pr.10-52	Injection magnitude (for IPM)	V	15.0 / 30.0	0.0–200.0
Pr.10-53	PM initial rotor position detection method	N/A	0	0–3
Motor Performance Control Parameters				
Pr.11-00	System control	bit	0	0–8
Pr.11-02	ASR1 / ASR2 switch frequency	Hz	7	5.00–599
Pr.11-03	ASR1 low-speed bandwidth	Hz	10	1–100 (PM) 1–40 (IM)
Pr.11-04	ASR2 high-speed bandwidth	Hz	10	1–100 (PM) 1–40 (IM)
Pr.11-05	Zero-speed bandwidth	Hz	10	1–100 (PM) 1–40 (IM)

# Chapter 13 Warning Codes

①	Warning	①	Display error signal
②	CE01	②	Abbreviate error code
③	Comm. Error 1	③	Display error description

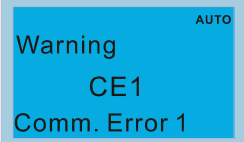
ID No.	Display on LCM Keypad	Warning Name	Description
1		Communication error 1 (CE1)	RS-485 Modbus illegal function code
<b>Action and Reset</b>			
Action level		When the function code is not 03, 06, 10 and 63	
Action time		Immediately act	
Warning setting parameter		N/A	
Reset method		“Warning” occurs when Pr. 09-02=0 and the motor drive keeps running. The drive resets automatically when receiving the correct function code.	
Reset condition		Immediately reset	
Record		N/A	
Cause		<b>Corrective Actions</b>	
Incorrect communication command from upper unit		Check if the communication command is correct.	
Malfunction caused by interference		Verify the wiring and grounding of the communication circuit. It is recommended to separate the communication circuit from the main circuit, or wire in 90 degree for effective anti-interference performance.	
Different communication setting from the upper unit		Check if the setting for Pr. 09-02 is the same as the setting for the upper unit.	
Disconnection or bad connection of the cable		Check the cable and replace it if necessary.	

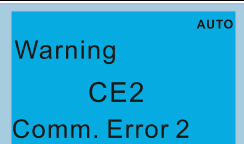
ID No.	Display on LCM Keypad	Warning Name	Description
2		Communication error 2 (CE2)	RS-485 Modbus illegal data address
<b>Action and Reset</b>			
Action level		When the input data address is incorrect	
Action time		Immediately act	
Warning setting parameter		N/A	
Reset method		“Warning” occurs when Pr. 09-02=0 and the motor drive keeps running. The drive resets automatically when receiving the correct data address.	
Reset condition		Immediately reset	
Record		N/A	
Cause		<b>Corrective Actions</b>	
Incorrect communication command from upper unit		Check if the communication command is correct.	
Malfunction caused by interference		Verify the wiring and grounding of the communication circuit. It is recommended to separate the communication circuit from the main circuit, or wire in 90 degree for effective anti-interference performance.	
Different communication setting from the upper unit		Check if the setting for Pr. 09-02 is the same as the setting for the upper unit.	
Disconnection or bad connection of the cable		Check the cable and replace it if necessary.	

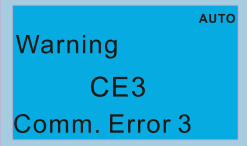

ID No.	Display on LCM Keypad	Warning Name	Description
3		Communication error 3 (CE3)	RS-485 Modbus illegal data value
<b>Action and Reset</b>			
Action level		When the length of communication data is too long	
Action time		Immediately act	
Warning setting parameter		N/A	
Reset method		“Warning” occurs when Pr. 09-02=0 and the motor drive keeps running. The drive resets automatically when receiving the correct communication data value.	
Reset condition		Immediately reset	
Record		N/A	
Cause		<b>Corrective Actions</b>	
Incorrect communication command from upper unit		Check if the communication command is correct.	
Malfunction caused by interference		Verify the wiring and grounding of the communication circuit. It is recommended to separate the communication circuit from the main circuit, or wire in 90 degree for effective anti-interference performance.	
Different communication setting from the upper unit		Check if the setting for Pr. 09-02 is the same as the setting for the upper unit.	
Disconnection or bad connection of the cable		Check the cable and replace it if necessary.	

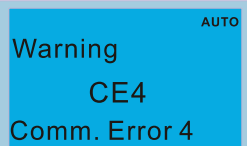
ID No.	Display on LCM Keypad	Warning Name	Description
4		Communication error 4 (CE4)	RS-485 Modbus data is written to read-only address
<b>Action and Reset</b>			
Action level		When the data is written to read-only address	
Action time		Immediately act	
Warning setting parameter		N/A	
Reset method		“Warning” occurs when Pr. 09-02=0 and the motor drive keeps running. The drive resets automatically when receiving the correct written address of communication data.	
Reset condition		Immediately reset	
Record		N/A	
Cause		<b>Corrective Actions</b>	
Incorrect communication command from upper unit		Check if the communication command is correct.	
Malfunction caused by interference		Verify the wiring and grounding of the communication circuit. It is recommended to separate the communication circuit from the main circuit, or wire in 90 degree for effective anti-interference performance.	
Different communication setting from the upper unit		Check if the setting for Pr. 09-02 is the same as the setting for the upper unit.	
Disconnection or bad connection of the cable		Check the cable and replace it if is necessary.	

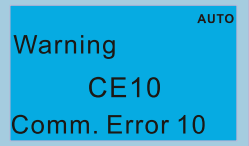
ID No.	Display on LCM Keypad	Warning Name	Description
5		Communication error 10 (CE10)	RS-485 Modbus transmission time-out
<b>Action and Reset</b>			
Action level	When the communication time exceeds the detection time of Pr. 09-03 communication time-out		
Action time	Setting for Pr. 09-03		
Warning setting parameter	N/A		
Reset method	"Warning" occurs when Pr. 09-02=0 and the motor drive keeps running. The drive resets automatically when receiving the next communication packet.		
Reset condition	Immediately reset		
Record	N/A		
Cause	<b>Corrective Actions</b>		
The upper unit does not transmit the communication command within Pr. 09-03 setting time	Check if the upper unit transmits the communication command within the setting time for Pr. 09-03.		
Malfunction caused by interference	Verify the wiring and grounding of the communication circuit. It is recommended to separate the communication circuit from the main circuit, or wire in 90 degree for effective anti-interference performance.		
Different communication setting from the upper unit	Check if the setting for Pr.09-02 is the same as the setting for the upper unit.		
Disconnection or bad connection of the cable	Check the cable and replace it if necessary.		

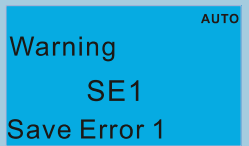
ID No.	Display on LCM Keypad	Warning Name	Description
7		Save error 1 (SE1)	Keypad COPY error 1: Keypad copy time-out
<b>Action and Reset</b>			
Action level	"SE1" warning occurs when the keypad does not transmit the COPY command to the drive, and does not transmit any data to the drive again in 10 ms at the time you copy the parameters to the drive.		
Action time	10 ms		
Warning setting parameter	N/A		
Reset method	Manual reset		
Reset condition	Immediately reset		
Record	N/A		
Cause	<b>Corrective Actions</b>		
Communication connection error	SE1: The causes of error are mostly communication problems between the keypad and control board. Potential causes include communication signal interference and the unacceptable communication command to the Slave. Check if the error occurs randomly, or only occurs when copying certain parameters (the error displays on the upper right corner of the copy page). If you cannot clear the error, please contact Delta.		
Keypad error			
Control board error			

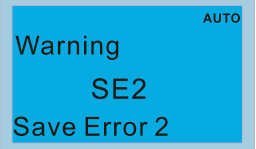
ID No.	Display on LCM Keypad	Warning Name	Description
8		Save error 2 (SE2)	Keypad COPY error 2: parameter writing error
<b>Action and Reset</b>			
Action level	"SE2" warning occurs when writing the parameters incorrectly at the time you copy parameters to the drive. For example, you copy the new firmware version with added parameters to the drive with old firmware version.		
Action time	N/A		
Warning setting parameter	N/A		
Reset method	Manual reset		
Reset condition	Immediately reset		
Record	N/A		
Cause	<b>Corrective Actions</b>		
Add new parameters to the new firmware version.	SE2: In this stage, the copied data has been transmitted to the Slave. The Slave compares and processes the copied data, and then saves the data to the Data ROM. During the process, the data error (should be attribution error) may occur, or the data cannot be saved to EEPROM. At this time, the warning occurs. It is suggested to check the status of Data ROM and remove the error causes first. If you cannot clear the error, please contact Delta.		
Malfunction caused by interference	Verify the wiring and grounding of the main circuit, control circuit and the encoder for effective anti-interference performance.		

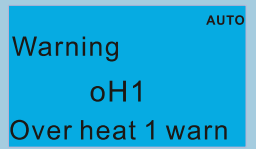
ID No.	Display on LCM Keypad	Warning Name	Description
9		IGBT over-heating warning (oH1)	The AC motor drive detects over-heating of IGBT, and over the protection level of oH1 warning. (When Pr. 06-15 is higher than the IGBT over-heating level, the drive shows oH1 error without displaying oH1 warning.)
<b>Action and Reset</b>			
Action level	Pr. 06-15		
Action time	"oH1" warning occurs when IGBT temperature is higher than Pr. 06-15 setting value.		
Warning setting parameter	N/A		
Reset method	Auto-reset		
Reset condition	The drive auto-resets when IGBT temperature is lower than oH1 warning level minus (-) 5°C		
Record	N/A		
Cause	<b>Corrective Actions</b>		
Check if the ambient temperature or temperature inside the cabinet is too high, or if there is obstruction in the ventilation hole of the control cabinet.	<ol style="list-style-type: none"> <li>1. Check the ambient temperature.</li> <li>2. Regularly inspect the ventilation hole of the control cabinet.</li> <li>3. Change the installed place if there are heating objects, such as braking resistors, in the surroundings.</li> <li>4. Install/ add cooling fan or air conditioner to lower the temperature inside the cabinet.</li> </ol>		
Check if there is any obstruction on the heat sink or if the fan is running	Remove the obstruction or replace the cooling fan.		
Insufficient ventilation space	Increase ventilation space of the drive.		
Check if the drive matches the corresponded loading	<ol style="list-style-type: none"> <li>1. Decrease loading.</li> <li>2. Decrease the carrier.</li> <li>3. Replace with a drive with larger capacity.</li> </ol>		
The drive has run 100% or more of the rated output for a long time	Replace with a drive with larger capacity.		

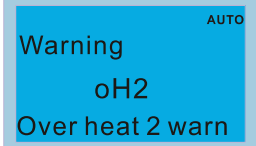
ID No.	Display on LCM Keypad	Warning Name	Description
10		Capacitor over-heat warning (oH2)	The drive has detected over heat of the capacitor
<b>Action and Reset</b>			
Action level		oH2 error level minus (–) 5°C	
Action time		The oH2 warning occurs when the capacitor temperature is higher than oH2 warning level	
Warning setting parameter		N/A	
Reset method		Auto-reset	
Reset condition		The drive auto-resets when the capacitor temperature is lower than oH2 error level minus (–) 10°C	
Record		N/A	
Cause		<b>Corrective Actions</b>	
Check if the ambient temperature or temperature inside the cabinet is too high, or if there is obstruction in the ventilation hole of the control cabinet.		<ol style="list-style-type: none"> <li>1. Check the ambient temperature.</li> <li>2. Regularly inspect the ventilation hole of the control cabinet.</li> <li>3. Change the installed place if there are heating objects, such as braking resistors, in the surroundings.</li> <li>4. Install/ add cooling fan or air conditioner to lower the temperature inside the cabinet.</li> </ol>	
Check if there is any obstruction on the heat sink or if the fan is running		Remove the obstruction or replace the cooling fan.	
Insufficient ventilation space		Increase ventilation space of the drive.	
Check if the drive matches the corresponded loading		<ol style="list-style-type: none"> <li>1. Decrease loading.</li> <li>2. Decrease the carrier.</li> <li>3. Replace with a drive with larger capacity.</li> </ol>	
The drive has run 100% or more of the rated output for a long time		Replace with a drive with larger capacity.	
Unstable power		Install reactor(s).	
The load changes frequently		Reduce the changes of the load.	

## oH1/ oH2 warning level

Model	oH1	oH2	oH warning oH1 warning = (Pr.06-15)	
VFD007C23A	110	95	oH1 Warning = oH1 – 5 oH2 Warning = oH2 – 5	
VFD015C23A				
VFD022C23A				
VFD037C23A		100		
VFD055C23A		80		
VFD075C23A				
VFD110C23A				
VFD150C23A		75		
VFD185C23A		65		
VFD220C23A				
VFD300C23A/E				
VFD370C23A/E				
VFD450C23A/E				
VFD550C23A/E				
VFD750C23A/E		110		95
VFD900C23A/E				
VFD007C43A/E	110		100	
VFD015C43A/E				
VFD022C43A/E			105	
VFD037C43A/E			100	
VFD040C43A/E				
VFD055C43A/E				
VFD075C43A/E		80		

Model	oH1	oH2	oH warning oH1 warning = (Pr.06-15)																
VFD110C43A/E	110	80	oH1 Warning = oH1 – 5 oH2 Warning = oH2 – 5																
VFD150C43A/E		85																	
VFD185C43A/E				65															
VFD220C43A/E					70														
VFD300C43A/E						70													
VFD370C43S/U							70												
VFD450C43S/U								70											
VFD550C43A/E									70										
VFD750C43A/E										70									
VFD900C43A/E											70								
VFD1100C43A/E												70							
VFD1320C43A/E													70						
VFD1600C43A/E														70					
VFD1850C43A/E															70				
VFD2200C43A/E																70			
VFD2800C43A/E																	70		
VFD3150C43A/E																		70	
VFD3550C43A/E																			70
VFD4500C43A/E	70																		
VFD015C53A		100	85																
VFD022C53A		105		70															
VFD037C53A		100																	
VFD055C53A					70														
VFD075C53A						70													
VFD110C53A							70												
VFD150C53A								70											
VFD185C63B			90						85	oH1 Warning = oH1 – 5 oH2 Warning = oH2 – 5									
VFD220C63B				85															
VFD300C63B		65																	
VFD370C63B					70														
VFD450C63B			110																
VFD550C63B				70															
VFD750C63B		70																	
VFD900C63B					70														
VFD1100C63B						70													
VFD1320C63B							70												
VFD1600C63B	70																		
VFD2000C63B								70											
VFD2500C63B									70										
VFD3150C63B											70								
VFD4000C63B												70							
VFD4500C63B													70						
VFD5600C63B			70																
VFD6300C63B				70															

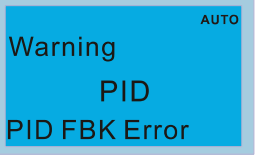
ID No.	Display on LCM Keypad	Warning Name	Description
11		PID feedback error (PID)	PID feedback loss (warning for analog feedback signal; works only when PID enables)
<b>Action and Reset</b>			
Action level	When the analog input is lower than 4mA (only detects analog input of 4–20mA)		
Action time	Pr. 08-08		
Warning setting parameter	Pr. 08-09 0: Warn and keep operation 1: Warn and ramp to stop 2: Warn and coast to stop 3: Warn and operate at last frequency		
Reset method	Auto	"Warning" occurs when Pr. 08-09=0 or 3. The "Warning" automatically clears when the feedback signal is larger than 4mA.	
	Manual	"Error" occurs when Pr. 08-09=1 or 2. You must reset manually.	
Reset condition	Immediately reset		
Record	Records when Pr. 08-09=1 or 2 ("Error"). Does not record when Pr. 08-09=3 ("Warning").		
Cause	<b>Corrective Actions</b>		
Loose or broken PID feedback wiring	Tighten the terminals again. Replace with a new cable.		
Feedback device malfunction	Replace with a new feedback device.		
Hardware error	If the PID error still occurs after checking all the wiring, return to the factory for repair.		

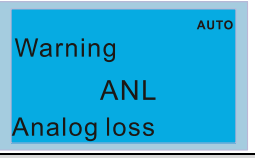
ID No.	Display on LCM Keypad	Warning Name	Description
12		ACI analog signal loss (AnL)	Analog input current loss (including all analog 4–20mA signals)
<b>Action and Reset</b>			
Action level	When the analog input is lower than 4mA (only detects analog input 4–20mA)		
Action time	Immediately act		
Warning setting parameter	Pr. 03-19 0: Disable 1: Continue operation at the last frequency (warning, keypad displays ANL) 2: Decelerate to 0Hz (warning, keypad displays ANL) 3: Stop immediately and display ACE		
Reset method	Auto	"Warning" occurs when Pr. 03-19=1 or 2. The "Warning" automatically clears when the analog input signal is larger than 4mA.	
	Manual	"Error" occurs when Pr. 03-19=3. You must reset manually.	
Reset condition	Immediately reset		
Record	Does not record when Pr. 03-19=1 or 2 ("Warning").		
Cause	<b>Corrective Actions</b>		
Loose or broken ACI wiring	Tighten the terminals again. Replace with a new cable.		
External device error	Replace new device.		
Hardware error	If the AnL error still occurs after checking all the wiring, return to the factory for repair.		

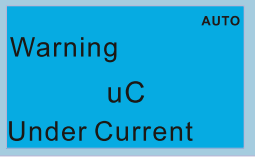
ID No.	Display on LCM Keypad	Warning Name	Description
13		Under current (uC)	Low current
<b>Action and Reset</b>			
Action level		Pr. 06-71	
Action time		Pr. 06-72	
Warning setting parameter		Pr. 06-73 0: No function 1: Warn and coast to stop 2: Warn and ramp to stop by 2 <sup>nd</sup> deceleration time 3: Warn and operation continue	
Reset method		Auto	"Warning" occurs when Pr. 06-73=3. The "Warning" automatically clears when the output current is > (Pr. 06-71+0.1A). "Error" occurs when Pr. 06-73=1 and 2. You must reset manually.
		Manual	
Reset condition		Immediately reset	
Record		Does not record when Pr. 06-73=3 and uC displays "Warning".	
Cause		<b>Corrective Actions</b>	
Broken motor cable		Exclude the connection issue of the motor and its load.	
Improper setting for the low current protection		Set the proper settings for Pr. 06-71, Pr. 06-72 and Pr. 06-73.	
Low load		Check the loading status. Make sure the loading matches the motor capacity.	

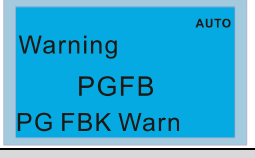
ID No.	Display on LCM Keypad	Warning Name	Description
15		PG feedback warning (PGFb)	PG feedback error warning
<b>Action and Reset</b>			
Action level		Motor runs in a reverse direction to the direction of frequency command	
Action time		Pr. 10-09	
Warning setting parameter		Pr. 10-08=0 0: Warn and operation continue 1: Warn and ramp to stop 2: Warn and coast to stop	
Reset method		Auto-reset	
Reset condition		"Warning" automatically clears when the drive stops	
Record		N/A	
Cause		<b>Corrective Actions</b>	
Incorrect encoder parameter setting		Reset encoder parameter (Pr. 10-02).	
Check if the connection of encoder is loss		Wiring again.	
Broken PG card or PG encoder		Replace with a new PG card or encoder.	
Malfunction caused by interference		Verify wiring of the control circuit, and wiring/grounding of the main circuit to prevent interference.	

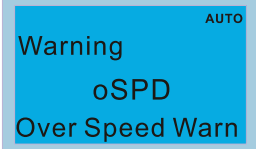
ID No.	Display on LCM Keypad	Warning Name	Description
17		Over speed warning (oSPd)	Over speed warning
<b>Action and Reset</b>			
Action level		The encoder feedback speed > Pr. 10-10	
Action time		Pr. 10-11	
Warning setting parameter		Pr. 10-12=0 0: Warn and keep operation	
Reset method		"Warning" automatically clears when the drive stops	
Reset condition		"Warning" automatically clears when the drive stops	
Record		N/A	
Cause		<b>Corrective Actions</b>	
Improper setting for Pr. 10-25 FOC bandwidth of speed observer		Decrease setting value for Pr. 10-25.	
Improper bandwidth setting for ASR speed controller		Increase the bandwidth setting for ASR speed controller.	
Incorrect motor parameter setting		Reset motor parameter and run parameter tuning.	
Malfunction caused by interference		Verify wiring of the control circuit, and wiring/grounding of the main circuit to prevent interference.	

ID No.	Display on LCM Keypad	Warning Name	Description
18		Deviation Warning (dAvE)	Over speed deviation warning
<b>Action and Reset</b>			
Action level		Pr. 10-13	
Action time		Pr. 10-14	
Warning setting parameter		Pr. 10-15=0 0: Warn and keep operation	
Reset method		"Warning" automatically clears when the drive stops	
Reset condition		After the drive stops	
Record		N/A	
Cause		<b>Corrective Actions</b>	
Improper parameter setting for the slip error		Reset proper value for Pr. 10-13 and Pr. 10-14.	
Improper setting for ASR parameter and acceleration/ deceleration		Reset ASR parameters. Set proper accel./ decel. time.	
Accel./ Decel. time is too short		Reset proper accel./ decel. time.	
Motor locked		Remove the causes of motor locked.	
Mechanical brake is not released		Check the active timing of the system.	
Incorrect parameter setting of torque limit (Pr. 06-12, Pr. 11-17-20)		Adjust to proper setting value.	
Malfunction caused by interference		Verify wiring of the control circuit, and wiring/grounding of the main circuit to prevent interference.	



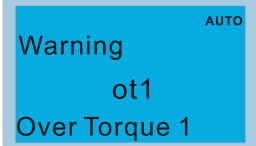

ID No.	Display on LCM Keypad	Warning Name	Description
19		Phase loss (PHL)	Input phase loss warning
<b>Action and Reset</b>			
Action level		One of the phases outputs less than Pr. 06-47	
Action time		Pr. 06-46	
Warning setting parameter		Pr. 06-45=0 0: Warn and keep operation	
Reset method		"Warning" automatically clears when the drive stops	
Reset condition		After the drive stops	
Record		N/A	
<b>Cause</b>		<b>Corrective Actions</b>	
Phase loss of the input power		Verify wiring of the main circuit.	
Single phase power input on a three-phase model		Use the model with voltage that matches the power.	
The power voltage has changed		If the power of main circuit works well, check if the MC of the main circuit is broken. Cycle the power after verifying the power is normal. If PHL still occurs, return to the factory for repair.	
Loose wiring terminal of input power		Tighten the terminal screws with the torque listed in the user manual.	
Check if the input cable of 3-phase power is broken		Make sure the wiring is correct. Replace the broken part of the cable.	
The voltage of input power has changed		Check setting for Pr. 06-50 (Time for Input Phase Loss Detection) and Pr. 06-52 (Ripple of Input Phase Loss).	
Unbalance three-phase of the input power		Check the status of 3-phase power.	

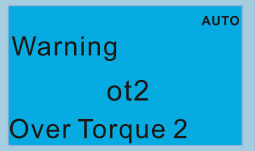
ID No.	Display on LCM Keypad	Warning Name	Description
20		Over-torque 1 (ot1)	Over-torque 1 warning
<b>Action and Reset</b>			
Action level		Pr. 06-07	
Action time		Pr. 06-08	
Warning setting parameter		Pr. 06-06=1 or 3 0: No function 1: Continue operation after over-torque detection during constant speed operation 2: Stop after over-torque detection during constant speed operation 3: Continue operation after over-torque detection during RUN 4: Stop after over-torque detection during RUN	
Reset method		When input current < (Pr. 06-07 – 5%), the Ot1 warning automatically clears	
Reset condition		When input current < (Pr. 06-07 – 5%), the Ot1 warning automatically clears	
Record		N/A	
<b>Cause</b>		<b>Corrective Actions</b>	
Incorrect parameter setting		Configure the settings for Pr. 06-07 and Pr. 06-08 again.	
Mechanical error (e.g. mechanical lock due to over-torque)		Remove the causes of malfunction.	
The load is too large		Decrease the loading. Replace with a motor with larger capacity.	
Accel./ Decel. time and working cycle is too short		Increase the setting values for Pr. 01-12–01-19 (accel./ decel. time)	
V/F voltage is too high		Adjust the settings for Pr. 01-01–01-08 (V/F curve), especially the setting value for the mid-point voltage (if the mid-point voltage is set too small, the load capacity decreases at low-speed).	
The motor capacity is too small		Replace with a motor with larger capacity.	
Over-load during low-speed operation		Decrease the loading during low-speed operation. Increase the motor capacity.	
The torque compensation is too large		Adjust the torque compensation value (Pr. 07-26 torque compensation gain) until the output current decreases and the motor does not stall.	
Improper parameter settings for the speed tracking function (including restart after momentary power loss and restart after fault)		Correct the parameter settings for speed tracking. Start the speed tracking function. Adjust the maximum current for Pr. 07-09 speed tracking.	

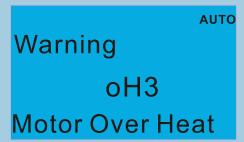
ID No.	Display on LCM Keypad	Warning Name	Description
21		Over-torque (ot2)	Over-torque 2 warning
<b>Action and Reset</b>			
Action level		Pr. 06-10	
Action time		Pr. 06-11	
Warning setting parameter		Pr. 06-09=1 or 3 0: No function 1: Continue operation after over-torque detection during constant speed operation 2: Stop after over-torque detection during constant speed operation 3: Continue operation after over-torque detection during RUN 4: Stop after over-torque detection during RUN	
Reset method		When output current < (Pr. 06-10 – 5%), the Ot2 warning automatically clears	
Reset condition		When output current < (Pr. 06-10 – 5%), the Ot2 warning automatically clears	
Record		N/A	
Cause		<b>Corrective Actions</b>	
Incorrect parameter setting		Configure the settings for Pr. 06-10 and Pr. 06-11	
Mechanical error (e.g. mechanical lock due to over-torque)		Remove the causes of malfunction.	
The load is too large		Decrease the loading. Replace with a motor with larger capacity.	
Accel./ Decel. time and working cycle is too short		Increase the setting values for Pr. 01-12–01-19 (accel./ decel. time)	
V/F voltage is too high		Adjust the V/F curve (Motor 2, Pr. 01-35–01-42), especially the setting value for the mid-point voltage (if the mid-point voltage is set too small, the load capacity decreases at low-speed).	
The motor capacity is too small		Replace with a motor with larger capacity.	
Over-load during low-speed operation		Decrease the loading during low-speed operation. Increase the motor capacity.	
The torque compensation is too large		Adjust the torque compensation value (Pr. 07-26 torque compensation gain) until the output current decreases and the motor does not stall.	
Improper parameter settings for the speed tracking function (including restart after momentary power loss and restart after fault)		Correct the parameter settings for speed tracking. Start speed tracking function. Adjust the maximum current for Pr. 07-09 speed tracking.	

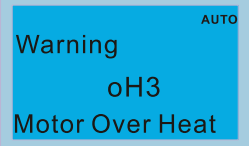
ID No.	Display on LCM Keypad	Warning Name	Description
22_1		Motor over-heating (oH3) PTC	Motor over-heating warning. The AC motor drive detects the temperature inside the motor is too high
<b>Action and Reset</b>			
Action level		Pr. 03-00=6 (PTC), PTC input level > Pr. 06-30 (default=50%)	
Action time		Immediately act	
Warning setting parameter		Error treatment: Pr. 06-29 0: Warn and keep operating 1: Warn and ramp to stop 2: Warn and coast to stop 3: No warning  When Pr. 06-29=0 and when the temperature is $\leq$ Pr. 06-30 level, the oH3 warning automatically clears. When Pr. 06-29=0 ("Warning"), it automatically resets.	
Reset method		When Pr. 06-29=0, oH3 displays "Warning". When the temperature is $\leq$ Pr. 06-30 level, the oH3 warning automatically clears.	
Reset condition		When the temperature is $\leq$ Pr. 06-30 level, the oH3 warning automatically clears.	
Record Cause		N/A	
		<b>Corrective Actions</b>	
Motor locked		Clear the motor lock status.	
The load is too large		Decrease the loading. Replace with a motor with larger capacity.	
Ambien temperature is too high		Change the installed place if there are heating devices in the surroundings. Install/ add cooling fan or air conditioner to lower the ambient temperature.	
Motor cooling system error		Check the cooling system to make it work normally.	
Motor fan error		Replace the fan.	
Operates at low-speed too long		Decrease low-speed operation time. Change to dedicated motor for the drive. Increase the motor capacity.	
Accel./ Decel. time and working cycle is too short		Increase setting values for Pr. 01-12-01-19 (accel./ decel. time).	
V/F voltage is too high		Adjust settings for Pr. 01-01-01-08 (V/F curve), especially the setting value for the mid-point voltage (if the mid-point voltage is set too small, the load capacity decreases at low-speed).	
Check if the motor rated current matches the motor nameplate		Configure the correct rated current value of the motor again.	
Check if the PTC is properly set and wired		Check the connection between PTC thermistor resistor and the heat protection.	
Check if the setting for stall prevention is correct		Set the stall prevention to the proper value.	
Unbalance three-phase impedance of the motor		Replace the motor.	
Harmonics is too high		Use remedies to reduce harmonics.	

ID No.	Display on LCM Keypad	Warning Name	Description
22_2		Motor over-heating (oH3) PT100	Motor over-heating warning. The AC motor drive detects the temperature inside the motor is too high.
<b>Action and Reset</b>			
Action level	Pr. 03-00=11 (PT100), PT100 input level > Pr. 06-57 (default=7V)		
Action time	Immediately act		
Warning setting parameter	Error treatment: Pr. 06-29 0: Warn and keep operating 1: Warn and ramp to stop 2: Warn and coast to stop 3: No warning  When Pr. 06-29=0 and when the temperature is < Pr. 06-56 level, the oH3 warning automatically clears. If the temperature is between Pr. 06-56 and Pr. 06-57, the frequency outputs according to the operating frequency setting for Pr. 06-58.		
Reset method	When Pr. 06-29=0, oH3 displays "Warning". When the temperature is < Pr. 06-56 level, the oH3 warning automatically clears.		
Reset condition	When the temperature is < Pr. 06-56 level, the oH3 warning automatically clears.		
Record	N/A		
Cause	<b>Corrective Actions</b>		
Motor locked	Clear the motor lock status.		
The load is too large	Decrease loading. Replace with a motor with larger capacity.		
Ambien temperature is too high	Change the installed place if there are heating devices in the surroundings. Install/ add cooling fan or air conditioner to lower the ambient temperature.		
Motor cooling system error	Check the cooling system to make it work normally.		
Motor fan error	Replace the fan.		
Operates at low-speed too long	Decrease low-speed operation time. Change to dedicated motor for the drive. Increase the motor capacity.		
Accel./ Decel. time and working cycle is too short	Increase the setting values for Pr. 01-12-01-19 (accel./ decel. time).		
V/F voltage is too high	Adjust the settings for Pr. 01-01-01-08 (V/F curve), especially the setting value for the mid-point voltage (if the mid-point voltage is set too small, the load capacity decreases at low-speed).		
Check if the motor rated current matches the motor nameplate	Configure the correct rated current value of the motor again.		
Check if the PT100 is properly set and wired	Check the connection between PT100 thermistor resistor and the heat protection.		
Check if the setting for stall prevention is correct	Set the stall prevention to the proper value.		
Unbalance three-phase impedance of the motor	Replace the motor.		
Harmonics is too high	Use remedies to reduce harmonics.		

ID No.	Display on LCM Keypad	Warning Name	Description
24		Over slip warning (oSL)	Over slip warning. By using the maximum slip (Pr. 10-29) as the base, when the drive outputs at constant speed, and the F>H or F<H exceeds Pr. 07-29 level and Pr. 07-30 setting time, 100% Pr. 07-29 = Pr. 10-29.
<b>Action and Reset</b>			
Action level		When the drive outputs at constant speed, and F>H or F<H exceeds the Pr. 07-29 level	
Action time		Pr. 07-30	
Warning setting parameter		Pr. 07-31=0 Warning 0: Warn and keep operation 1: Warn and ramp to stop 2: Warn and coast to stop 3: No warning	
Reset method		When Pr. 07-31=0 and when the drive outputs at constant speed, and F>H or F<H no longer exceeds the Pr. 07-29 level, the oSL warning automatically clears.	
Reset condition		N/A	
Record		N/A	
Cause		<b>Corrective Actions</b>	
Check if the motor parameter is correct		Check the motor parameter.	
The load is too large		Decrease the loading.	
Check if the settings for Pr. 07-29, Pr. 07-30 and Pr. 10-29 are properly set		Check the parameter settings for oSL protection.	

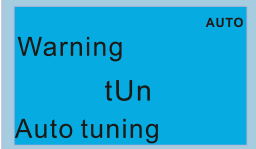
ID No.	Display on LCM Keypad	Warning Name	Description
25		Auto tuning (tUn)	Parameter auto-tuning is processing. When running auto-tuning, the keypad displays "tUn".
<b>Action and Reset</b>			
Action level		When running Pr. 05-00 motor parameter auto-tuning, the keypad displays "tUn".	
Action time		N/A	
Warning setting parameter		N/A	
Reset method		When auto-tuning is finished and no error occurs, the warning automatically clears.	
Reset condition		When auto-tuning is finished and no error occurs.	
Record		N/A	
Cause		<b>Corrective Actions</b>	
The motor parameter is running auto-tuning		When the auto-tuning is finished, the warning automatically clears.	

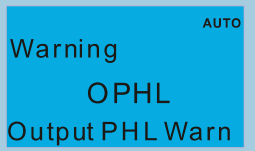
ID No.	Display on LCM Keypad	Warning Name	Description
28		Output phase loss (OPHL)	Output phase loss
<b>Action and Reset</b>			
Action level	Pr. 06-47		
Action time	N/A		
Warning setting parameter	Pr. 06-45 0: Warn and keep operating 1: Warn and ramp to stop 2: Warn and coast to stop 3: No warning		
Reset method	If Pr. 06-45 is set to 0, the OPHL warning automatically clears after the drive stops.		
Reset condition	N/A		
Record	N/A		
Cause	<b>Corrective Actions</b>		
Unbalanced three-phase impedance of the motor	Replace the motor.		
Check if the wiring is incorrect	Check the cable. Replace the cable.		
Check if the motor is a single-phase motor	Choose a three-phase motor.		
Check if the current sensor is broken	Check if the control board cable is loose. If yes, reconnect the cable and run the drive to test. If the error still occurs, return to the factory for repair. Check if the three-phase current is balanced with a current clamp meter. If the current is balanced and the OPHL error still shows on the display, return to the factory for repair.		
If capacity of the drive is larger than the motor	Choose the matches capacity of the drive and motor.		

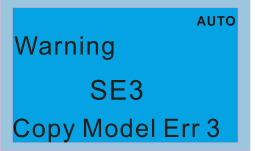
ID No.	Display on LCM Keypad	Warning Name	Description
30		Copy model error 3 (SE3)	Keypad COPY error 3: copy model error
<b>Action and Reset</b>			
Action level	"SE3" warning occurs when different drive identity codes are found during copying parameters.		
Action time	Immediately act when the error is detected		
Warning setting parameter	N/A		
Reset method	Manual reset		
Reset condition	N/A		
Record	N/A		
Cause	<b>Corrective Actions</b>		
Keypad copy between different power range drives	It is mainly to prevent parameter copies between different HP/models.		

ID No.	Display on LCM Keypad	Warning Name	Description
36	Warning CGdn Guarding T-out	CANopen guarding time-out (CGdn)	CANopen guarding time-out 1
<b>Action and Reset</b>			
Action level	When CANopen Node Guarding detects that one of the slaves does not response, the CGdn error displays. The upper unit sets factor and time during configuration.		
Action time	The time that upper unit sets during configuration		
Warning setting parameter	N/A		
Reset method	Manual reset		
Reset condition	The upper unit sends a reset package to clear this fault.		
Record	N/A		
Cause	<b>Corrective Actions</b>		
The guarding time is too short, or less detection times	Increase the guarding time (Index 100C) and detection times.		
Malfunction caused by interference	<ol style="list-style-type: none"> <li>1. Verify the wiring and grounding of the communication circuit. It is recommended to separate the communication circuit from the main circuit, or wire in 90 degree for effective anti-interference performance.</li> <li>2. Make sure the communication circuit is wired in series.</li> <li>3. Use CANopen cable or add terminating resistance.</li> </ol>		

ID No.	Display on LCM Keypad	Warning Name	Description
37	Warning CHbn Heartbeat T-out	CANopen heartbeat error (CHbn)	CANopen heartbeat error
<b>Action and Reset</b>			
Action level	When CANopen Heartbeat detects that one of the slaves does not response, the CHbn error shows. The upper unit sets the confirming time of producer and consumer during configuration.		
Action time	The upper unit sets the confirming time of producer and consumer during configuration.		
Warning setting parameter	N/A		
Reset method	Manual reset		
Reset condition	The upper unit sends a reset package to clear this fault		
Record	When Pr. 00-21≠3, CHbn is a "Warning", and the warning is not recorded		
Cause	<b>Corrective Actions</b>		
The heartbeat time is too short	Increase heartbeat time (Index 1016)		
Malfunction caused by interference	<ol style="list-style-type: none"> <li>1. Verify the wiring and grounding of the communication circuit. It is recommended to separate the communication circuit from the main circuit, or wire in 90 degree for effective anti-interference performance.</li> <li>2. Make sure the communication circuit is wired in series.</li> <li>3. Use CANopen cable or add terminating resistance.</li> </ol>		
Communication cable is broken or bad connected	Check or replace the communication cable.		

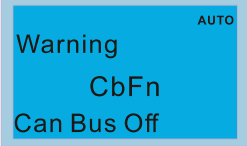

ID No.	Display on LCM Keypad	Warning Name	Description
39		CANopen bus off error (CbFn)	CANopen BUS off error
<b>Action and Reset</b>			
Action level		Hardware	When CANopen card is not installed, CbFn fault will occur.
		Software	When the master received wrong communication package, CbFn fault will occur. Too much interference on BUS When the CAN_H and CAN_L communication cable is short, the master receives wrong package, and CbFn fault occurs.
Action time		Immediately act when the fault is detected	
Warning setting parameter		N/A	
Reset method		Manual Reset	
Reset condition		Cycle the power	
Record		When Pr. 00-21≠3, CbFn is a "Warning", and the warning is not recorded	
Cause		Corrective Actions	
Check if the CANopen card is installed		Make sure the CANopen card is installed.	
Check if the CANopen speed is correct		Reset CANopen speed (Pr. 09-37)	
Malfunction caused by interference		<ol style="list-style-type: none"> <li>1. Verify the wiring and grounding of the communication circuit. It is recommended to separate the communication circuit from the main circuit, or wire in 90 degree for effective anti-interference performance.</li> <li>2. Make sure the communication circuit is wired in series.</li> <li>3. Use CANopen cable or add terminating resistance.</li> </ol>	
Communication cable is broken or bad connected		Check or replace the communication cable.	

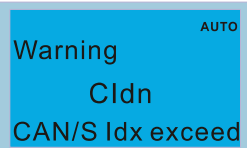
ID No.	Display on LCM Keypad	Warning Name	Description
40		CANopen index error (CIdn)	CANopen Index error
<b>Action and Reset</b>			
Action level		CANopen communication Index error	
Action time		Immediately act when the fault is detected	
Warning setting parameter		N/A	
Reset method		Manual Reset	
Reset condition		Upper unit sends a reset package to clear this fault	
Record		When Pr. 00-21≠3, CIdn is a "Warning", and the warning is not recorded	
Cause		Corrective Actions	
Incorrect setting of CANopen index		Reset CANopen Index (Pr. 00-02=7)	

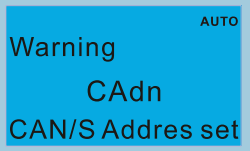
ID No.	Display on LCM Keypad	Warning Name	Description
41		CANopen station address error (CAdn)	CANopen station address error (only supports 1–127)
<b>Action and Reset</b>			
Action level		CANopen station address error	
Action time		Immediately act when the fault is detected	
Warning setting parameter		N/A	
Reset method		Manual Reset	
Reset condition		Pr. 00-02=7	
Record		When Pr. 00-21≠3, CAdn is a “Warning”, and the warning is not recorded	
Cause		<b>Corrective Actions</b>	
Incorrect setting of CANopen station address		<ol style="list-style-type: none"> <li>1. Disable CANopen (Pr. 09-36=0)</li> <li>2. Reset CANopen (Pr. 00-02=7)</li> <li>3. Reset CANopen station address (Pr. 09-36)</li> </ol>	

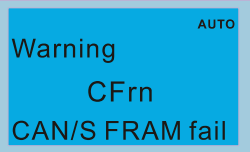
ID No.	Display on LCM Keypad	Warning Name	Description
42		CANopen memory error (CFrn)	CANopen memory error
<b>Action and Reset</b>			
Action level		When the user update firmware version of the control board, the FRAM internal data will not be changed, then CFrn fault will occur.	
Action time		Immediately act when the fault is detected	
Warning setting parameter		N/A	
Reset method		Manual Reset	
Reset condition		Pr. 00-02=7	
Record		When Pr. 00-21≠3, CFrn is a “Warning”, and the warning is not recorded	
Cause		<b>Corrective Actions</b>	
CANopen internal memory error		<ol style="list-style-type: none"> <li>1. Disable CANopen (Pr. 09-36=0)</li> <li>2. Reset CANopen (Pr. 00-20=7)</li> <li>3. Reset CANopen station address (Pr. 09-36)</li> </ol>	

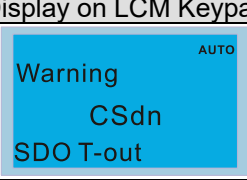
ID No.	Display on LCM Keypad	Warning Name	Description
43		CANopen SDO time-out (CSdn)	SDO transmission time-out (only shows on master station)
<b>Action and Reset</b>			
Action level		When the CANopen master transmits SDO command, and the Slave response "time-out", CSdn warning will occur.	
Action time		Immediately act when the fault is detected	
Warning setting parameter		N/A	
Reset method		When the master resends a SDO command and receives the response, the warning automatically clears.	
Reset condition		N/A	
Record		N/A	
<b>Cause</b>		<b>Corrective Actions</b>	
Slave is not connected		Connect slave and CANopen BUS.	
The synchronize cycle is set too short		Increase the synchronization time (Index 1006)	
Malfunction caused by interference		<ol style="list-style-type: none"> <li>1. Verify the wiring and grounding of the communication circuit. It is recommended to separate the communication circuit from the main circuit, or wire in 90 degree for effective anti-interference performance.</li> <li>2. Make sure the communication circuit is wired in series.</li> <li>3. Use CANopen cable or add terminating resistance.</li> </ol>	
Disconnection or bad connection of the communication cable		Check the status of the cable, or replace the cable.	

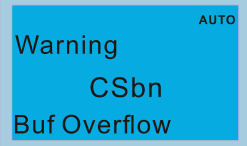
ID No.	Display on LCM Keypad	Warning Name	Description
44		CANopen SDO receives register overflow (CSbn)	CANopen SDO receives register overflow
<b>Action and Reset</b>			
Action level		The upper unit sends too much SDO and causes buffer overflow	
Action time		Immediately act when the fault is detected	
Warning setting parameter		N/A	
Reset method		The upper unit sends a reset package to clear the warning.	
Reset condition		N/A	
Record		N/A	
<b>Cause</b>		<b>Corrective Actions</b>	
Too much SDO from the upper unit		Check if the master sends too much SDO command. Make sure the master sends SDO command according to the command format.	

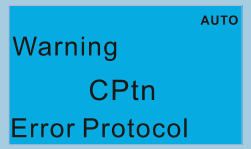
ID No.	Display on LCM Keypad	Warning Name	Description
46		CANopen format error (CPtn)	CANopen protocol format error
<b>Action and Reset</b>			
Action level	The slave detects that data from the upper unit cannot be recognized, and then shows CPtn warning		
Action time	Immediately displays when the fault is detected		
Warning setting parameter	N/A		
Reset method	The upper unit sends a reset packet to clear the warning		
Reset condition	N/A		
Record	N/A		
Cause	<b>Corrective Actions</b>		
The upper unit sends incorrect communication packet	Make sure the master sends the packet based on CANopen DS301 standard command format.		

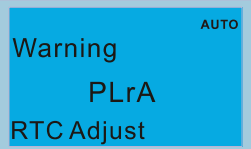
ID No.	Display on LCM Keypad	Warning Name	Description
47		RTC adjust (PLrA)	PLC (RTC) is not adjusted
<b>Action and Reset</b>			
Action level	When using RTC function for PLC program, and PLC detects unreasonable RTC time, PLrA warning displays.		
Action time	Immediately displays when the fault is detected		
Warning setting parameter	N/A		
Reset method	Auto	Stops the PLC and runs again, the warning automatically clears	
	Manual	Manual reset to clear this warning	
Reset condition	Cycle the power		
Record	N/A		
Cause	<b>Corrective Actions</b>		
When using RTC function for PLC program, and the drive is power off over 7 days or KPC-CC01 does not connect to the drive for a long time, the RTC time is different with the internal calculated time when re-connect the keypad to the drive.	<ol style="list-style-type: none"> <li>1. Stop the PLC program and restart it.</li> <li>2. Adjust the RTC time and cycle the power.</li> </ol>		
KPC-CC01 does not adjust the RTC time	Adjust the RTC time and cycle the power.		
PLC detects unreasonable RTC time	<ol style="list-style-type: none"> <li>1. Stop the PLC program and restart it.</li> <li>2. Cycle the power.</li> </ol>		
Replace with a new KPC-CC01	<ol style="list-style-type: none"> <li>1. Stop the PLC program and restart it.</li> <li>2. Cycle the power.</li> </ol>		

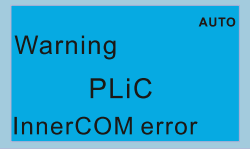
ID No.	Display on LCM Keypad	Warning Name	Description
48		InnerCOM error (PLiC)	InnerCOM error
<b>Action and Reset</b>			
Action level		N/A	
Action time		N/A	
Warning setting parameter		N/A	
Reset method		N/A	
Reset condition		When InnerCOM is back to normal condition, the warning automatically clears	
Record		N/A	
Cause		<b>Corrective Actions</b>	
Communication cable is loose		Check the connection of the communication cable	
Malfunction caused by interference		Verify the wiring and grounding of the communication circuit. It is recommended to separate the communication circuit from the main circuit, or wire in 90 degree for effective anti-interference performance. It recommended to install terminal resistor(s) on the first and the last unit of the communication circuit.	

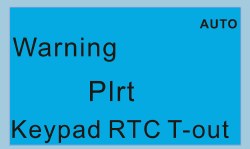
ID No.	Display on LCM Keypad	Warning Name	Description
49		Keypad RTC time-out (PLrt)	PLC (RTC) error
<b>Action and Reset</b>			
Action level		N/A	
Action time		N/A	
Warning setting parameter		N/A	
Reset method		N/A	
Reset condition		Cycle the power	
Record		N/A	
Cause		<b>Corrective Actions</b>	
KPC-CC01 is not connected to the control board while using the RTC function		Do not remove the KPC-CC01 keypad while using RTC function.	

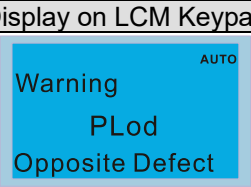
ID No.	Display on LCM Keypad	Warning Name	Description
50		PLC opposite defect (PLOd)	PLC download error warning
<b>Action and Reset</b>			
Action level	During PLC downloading, the program source code detects incorrect address (e.g. the address exceeds the range), then the PLOd warning shows.		
Action time	Immediately displays when the fault is detected		
Warning setting parameter	N/A		
Reset method	Check if the program is correct and re-download the program. If the fault does not exist, the warning automatically clears.		
Reset condition	N/A		
Record	N/A		
Cause	<b>Corrective Actions</b>		
Incorrect component number is found when downloading the PLC program	Use the correct component number.		

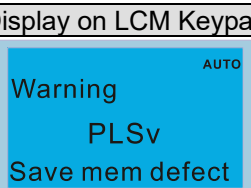
ID No.	Display on LCM Keypad	Warning Name	Description
51		PLC save memory error (PLSv)	Data error during PLC operation
<b>Action and Reset</b>			
Action level	The program detects incorrect written address (e.g. the address has exceeds the range) during PLC operation, then the PLSv warning shows.		
Action time	Immediately displays when the fault is detected		
Warning setting parameter	N/A		
Reset method	Check if the program is correct and re-download the program. If the fault does not exist, the warning automatically clears.		
Reset condition	N/A		
Record	N/A		
Cause	<b>Corrective Actions</b>		
An incorrect written address is detected during PLC operation	Make sure the write-in address is correct and re-download the program.		

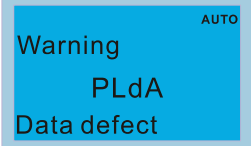
ID No.	Display on LCM Keypad	Warning Name	Description
52		Data defect (PLdA)	Data error during PLC operation
<b>Action and Reset</b>			
Action level		The program detects incorrect write-in address when translating the program source code, then PLSv warning acts.	
Action time		Immediately displays when the fault is detected	
Warning setting parameter		N/A	
Reset method		Check if the program is correct and re-download the program. If the fault does not exist, the warning automatically clears.	
Reset condition		N/A	
Record		N/A	
Cause		<b>Corrective Actions</b>	
During PLC operation, the external Modbus has written/read incorrect data to internal PLC program		Check if the upper unit transmits the correct command	

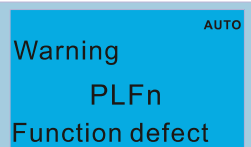
ID No.	Display on LCM Keypad	Warning Name	Description
53		Function defect (PLFn)	PLC download function code error
<b>Action and Reset</b>			
Action level		The program detects incorrect command (unsupported command) during PLC downloading, then PLFn warning acts.	
Action time		Immediately displays when the fault is detected	
Warning setting parameter		N/A	
Reset method		Check if the program is correct and re-download the program. If the fault does not exist, the warning automatically clears.	
Reset condition		N/A	
Record		N/A	
Cause		<b>Corrective Actions</b>	
Unsupported command has used while downloading the program		Check if the firmware of the drive is the old version. If yes, please contact Delta.	

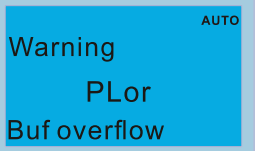
ID No.	Display on LCM Keypad	Warning Name	Description
54		PLC buffer overflow (PLor)	PLC register overflow
<b>Action and Reset</b>			
Action level	When PLC runs the last command and the command exceeds the maximum capacity of the program, the PLor warning shows.		
Action time	Immediately displays when the fault is detected		
Warning setting parameter	N/A		
Reset method	Check if the program is correct and re-download the program. If the fault does not exist, the warning automatically clears.		
Reset condition	N/A		
Record	N/A		
Cause	<b>Corrective Actions</b>		
The program detects source code error during PLC operation	<ol style="list-style-type: none"> <li>1. Disable PLC</li> <li>2. Delete PLC program (Pr. 00-02=6)</li> <li>3. Enable PLC</li> <li>4. Re-download PLC program</li> </ol>		

ID No.	Display on LCM Keypad	Warning Name	Description
55		Function defect (PLFF)	Function code error during PLC operation
<b>Action and Reset</b>			
Action level	The program detects incorrect command (unsupported command) during PLC operation, then PLFF warning shows.		
Action time	Immediately displays when the fault is detected		
Warning setting parameter	NA		
Reset method	Check if the program is correct and re-download the program. If the fault does not exist, the warning automatically clears.		
Reset condition	N/A		
Record	N/A		
Cause	<b>Corrective Actions</b>		
The PLC runs an incorrect command during operation	When starting the PLC function and there is no program in the PLC, the PLFF warning shows. This is a normal warning, please download the program.		

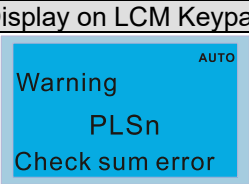

ID No.	Display on LCM Keypad	Warning Name	Description
56		Checksum error (PLSn)	PLC checksum error
<b>Action and Reset</b>			
Action level	PLC checksum error is detected after power on, then PLSn warning shows		
Action time	Immediately displays when the fault is detected		
Warning setting parameter	NA		
Reset method	Check if the program is correct and re-download the program. If the fault does not exist, the warning automatically clears.		
Reset condition	N/A		
Record	N/A		
Cause	<b>Corrective Actions</b>		
The program detects checksum error during PLC operation	<ol style="list-style-type: none"> <li>1. Disable PLC</li> <li>2. Remove PLC program (Pr. 00-02=6)</li> <li>3. Enable PLC</li> <li>4. Re-download PLC program</li> </ol>		

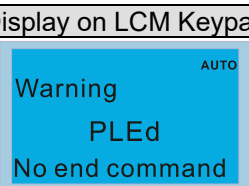
ID No.	Display on LCM Keypad	Warning Name	Description
57		No end command (PLEd)	PLC end command is missing
<b>Action and Reset</b>			
Action level	The “End” command is missing until the last command is executed, the PLEd warning shows		
Action time	Immediately displays when the fault is detected		
Warning setting parameter	NA		
Reset method	Check if the program is correct and re-download the program. If the fault does not exist, the warning automatically clears.		
Reset condition	N/A		
Record	N/A		
Cause	<b>Corrective Actions</b>		
There is no “END” command during PLC operation	<ol style="list-style-type: none"> <li>1. Disable PLC</li> <li>2. Remove PLC program (Pr. 00-02=6)</li> <li>3. Enable PLC</li> <li>4. Re-download PLC program</li> </ol>		

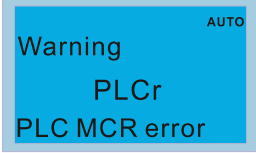
ID No.	Display on LCM Keypad	Warning Name	Description
58		PLC MCR error (PLCr)	PLC MCR command error
<b>Action and Reset</b>			
Action level	The MC command is detected during PLC operation, but there is no corresponded MCR command, then the PLCr warning shows.		
Action time	Immediately displays when the fault is detected		
Warning setting parameter	NA		
Reset method	Check if the program is correct and re-download the program. If the fault does not exist, the warning automatically clears.		
Reset condition	N/A		
Record	N/A		
Cause	<b>Corrective Actions</b>		
The MC command is continuously used for more than 9 times	The MC command cannot be used continuously for 9 times. Check and reset the program, then re-download the program.		

ID No.	Display on LCM Keypad	Warning Name	Description
59		PLC download fail (PLdF)	PLC download fail
<b>Action and Reset</b>			
Action level	PLC download fail due to momentary power loss during the downloading, when power is ON again, PLdF warning shows.		
Action time	Immediately displays when the fault is detected		
Warning setting parameter	NA		
Reset method	Check if the program is correct and re-download the program. If the fault does not exist, the warning automatically clears.		
Reset condition	N/A		
Record	N/A		
Cause	<b>Corrective Actions</b>		
PLC download is forced to stop, so the program write-in is incompleted	Check if there is any error in the program and re-download the PLC program		

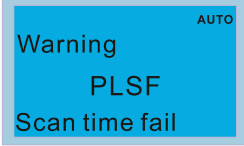
ID No.	Display on LCM Keypad	Warning Name	Description
60		PLC scan time fail (PLSF)	PLC scan time exceeds the maximum allowable time
<b>Action and Reset</b>			
Action level		When the PLC scan time exceeds the maximum allowable time (400ms), PLSF warning shows.	
Action time		Immediately displays when the fault is detected	
Warning setting parameter		NA	
Reset method		Check if the program is correct and re-download the program. If the fault does not exist, the warning automatically clears.	
Reset condition		N/A	
Record		N/A	
<b>Cause</b>		<b>Corrective Actions</b>	
The PLC scan time exceeds the maximum allowable time (400ms)		Check if the source code is correct and re-download the program	

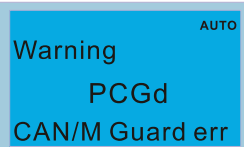
ID No.	Display on LCM Keypad	Warning Name	Description
61		CAN/M guarding error (PCGd)	CANopen Master guarding error
<b>Action and Reset</b>			
Action level		When CANopen Master Node Guarding detects that one of the Slaves does not response, the PCGd warning will display	
Action time		Immediately displays when the fault is detected	
Warning setting parameter		NA	
Reset method		Check if the program is correct and re-download the program. If the fault does not exist, the warning automatically clears.	
Reset condition		N/A	
Record		N/A	
<b>Cause</b>		<b>Corrective Actions</b>	
Slave is not connected or CANopen BUS cable is not connected		Connect the Slave and CANopen BUS	
Malfunction caused by interference		<ol style="list-style-type: none"> <li>1. Verify wiring/grounding of the communication circuit. It is recommended to separate the communication circuit from the main circuit, or wire in 90 degree for effective anti-interference performance.</li> <li>2. Make sure the communication circuit is wired in series.</li> <li>3. Use CANopen cable or add terminating resistance.</li> </ol>	
Communication cable is broken or bad connected		Check or replace the communication cable.	

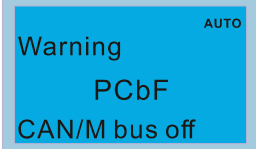
ID No.	Display on LCM Keypad	Warning Name	Description
62		CAN/M BUS off (PCbF)	CANopen Master BUS off
<b>Action and Reset</b>			
Action level	When the CANopen master detects error packets more than 255 during the BUS off detection, or when the CANopen card is not installed, the PCbF warning displays. If the BUS cable is not connected, the drive will not receive issues packet, and the PCbF warning will not display.		
Action time	Immediately displays when the fault is detected		
Warning setting parameter	NA		
Reset method	Cycle the power		
Reset condition	N/A		
Record	N/A		
Cause	<b>Corrective Actions</b>		
Malfunction caused by interference	<ol style="list-style-type: none"> <li>1. Verify wiring/grounding of the communication circuit. It is recommended to separate the communication circuit from the main circuit, or wire in 90 degree for effective anti-interference performance.</li> <li>2. Make sure the communication circuit is wired in series.</li> <li>3. Use CANopen cable or add terminating resistance.</li> </ol>		
Communication cable is broken or bad connected	Check or replace the communication cable.		

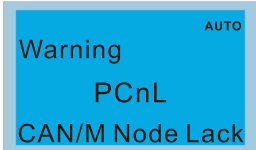
ID No.	Display on LCM Keypad	Warning Name	Description
63		CAN/M node lack (PCnL)	CANopen Master node error
<b>Action and Reset</b>			
Action level	When the CANopen master configures different setting nodes from the actual nodes, the PCnL warning displays.		
Action time	Immediately displays when the fault is detected		
Warning setting parameter	N/A		
Reset method	When connect BUS to the original slave, or change the configured node numbers to meet the actual node quantity, the warning automatically clears.		
Reset condition	N/A		
Record	N/A		
Cause	<b>Corrective Actions</b>		
The configured node quantity is different from the actual nodes	Connect BUS to the original slave, or change the configured node numbers to meet the actual node quantity		
Communication cable is broken or bad connected	Check or replace the communication cable.		

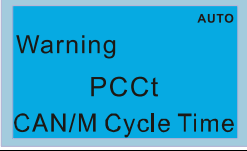
ID No.	Display on LCM Keypad	Warning Name	Description
64		CAN/M cycle time-out (PCct)	CANopen Master cycle time-out
<b>Action and Reset</b>			
Action level		When the transmitted packet from CANopen master exceeds the maximum allowable quantity in a certain time, the PCct warning displays.	
Action time		Immediately displays when the fault is detected	
Warning setting parameter		N/A	
Reset method		The warning automatically clears when changing the configuration and re-executing the program.	
Reset condition		N/A	
Record		N/A	
<b>Cause</b>		<b>Corrective Actions</b>	
When the transmitted packet from CANopen master exceeds the maximum allowable quantity in a certain time		Increase the time setting of D1090 synchronization cycle	

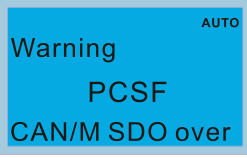
ID No.	Display on LCM Keypad	Warning Name	Description
65		CAN/M SDO over (PCSF)	CANopen Master SDO overflow
<b>Action and Reset</b>			
Action level		When the CANopen master transmits too much SDO that causes buffer overflow, the PCSF warning displays	
Action time		Immediately displays when the fault is detected	
Warning setting parameter		N/A	
Reset method		Cycle the power, or stop the PLC and run the PLC again	
Reset condition		N/A	
Record		N/A	
<b>Cause</b>		<b>Corrective Actions</b>	
Internal PLC transmits too much SDO at once		The PLC program needs to confirm receiving the SDO feedback data before sending another SDO command.	

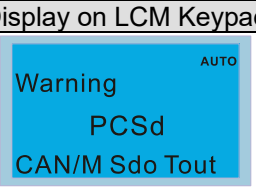
ID No.	Display on LCM Keypad	Warning Name	Description
66		CAN/M SDO time-out (PCSd)	CANopen Master SDO time-out
<b>Action and Reset</b>			
Action level		When the CANopen master sends a SDO command, and the BUS is too busy to transmit the command, PCSd warning displays.	
Action time		Immediately displays when the fault is detected	
Warning setting parameter		N/A	
Reset method		The warning automatically clears when the SDO transmits normally.	
Reset condition		N/A	
Record		N/A	
Cause		<b>Corrective Actions</b>	
When the CANopen master transmits a SDO command, and does not receive feedback from the Slave within 1 sec.		Check if the Slave responds within 1 second.	

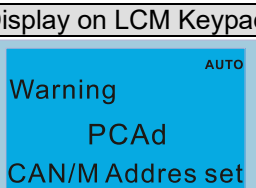
ID No.	Display on LCM Keypad	Warning Name	Description
67		CAN/M address error (PCAd)	CANopen Master station address error
<b>Action and Reset</b>			
Action level		When the CANopen master detects an incorrect or repeated station address from the Slave, the PCAd warning displays.	
Action time		Immediately displays when the fault is detected	
Warning setting parameter		N/A	
Reset method		The warning automatically clears when reset the station address and run the program again.	
Reset condition		N/A	
Record		N/A	
Cause		<b>Corrective Actions</b>	
When the CANopen master detects an incorrect or repeated station address from the Slave		Set the correct slave station address.	

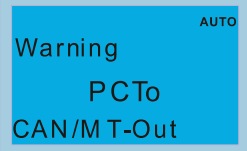
ID No.	Display on LCM Keypad	Warning Name	Description
68		CAN/M time-out (PCTo)	When the drive receives an incorrect packet, it means that there is interference or the command from the upper unit does not meet the CANopen command format.
<b>Action and Reset</b>			
Action level		N/A	
Action time		Immediately acts when receiving the command	
Warning setting parameter		N/A	
Reset method		The warning automatically clears after receives another normal packet	
Reset condition		N/A	
Record		N/A	
<b>Cause</b>		<b>Corrective Actions</b>	
Malfunction caused by interference		<ol style="list-style-type: none"> <li>1. Verify wiring/grounding of the communication circuit. It is recommended to separate the communication circuit from the main circuit, or wire in 90 degree for effective anti-interference performance.</li> <li>2. Make sure the communication circuit is wired in series.</li> <li>3. Use CANopen cable or add terminating resistance.</li> </ol>	
The command from the upper unit does not meet the CANopen format		Please contact Delta for further confirmation.	

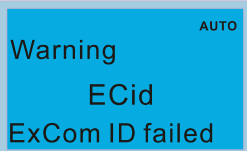
ID No.	Display on LCM Keypad	Warning Name	Description
70		ExCom ID fail (ECid)	Duplicate MAC ID error Node address setting error
<b>Action and Reset</b>			
Action level		Duplicate setting of MAC ID Node address setting error	
Action time		N/A	
Warning setting parameter		N/A	
Reset method		Correct the setting and cycle the power	
Reset condition		N/A	
Record		N/A	
<b>Cause</b>		<b>Corrective Actions</b>	
The setting address exceeds the range (0-63)		Check the address setting of the communication card (Pr. 09-70)	
The speed setting exceeds the range		Standard: 0-2, non-standard: 0-7	
The address is duplicated with other nodes on the BUS		Reset the address	

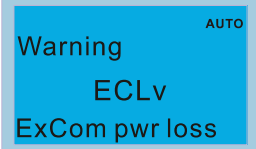
ID No.	Display on LCM Keypad	Warning Name	Description
71		ExCom power loss (ECLv)	Low voltage of communication card
<b>Action and Reset</b>			
Action level		The 5V power that drive provides to communication card is to low	
Action time		Immediately acts	
Warning setting parameter		N/A	
Reset method		Re-power	
Reset condition		N/A	
Record		N/A	
Cause		<b>Corrective Actions</b>	
The 5V power that drive provides to communication card is to low		<ol style="list-style-type: none"> <li>Switch the communication card to other C2000 drives and observe if there is ECLv warning shown. If yes, replace with a new communication card; if not, replace the drive.</li> <li>Use another communication card to test if the ECLv warning has shown as well. If not, replace the card; if yes, replace the drive.</li> </ol>	
The card is loose		Make sure the communication card is well inserted.	

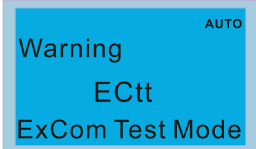
ID No.	Display on LCM Keypad	Warning Name	Description
72		ExCom test mode (ECtt)	Communication card is in the test mode
<b>Action and Reset</b>			
Action level		Communication card is in the test mode	
Action time		Immediately acts	
Warning setting parameter		N/A	
Reset method		Cycle the power and enter the normal mode	
Reset condition		N/A	
Record		N/A	
Cause		<b>Corrective Actions</b>	
Communication command error		Cycle the power	

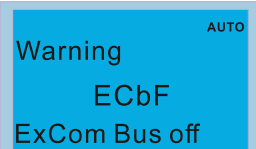
ID No.	Display on LCM Keypad	Warning Name	Description
73		ExCom Bus off (ECbF)	The communication card detects too much errors in the BUS, then enters the BUS-OFF status and stop communicating
<b>Action and Reset</b>			
Action level		When the drive detects BUS-off (for DeviceNet)	
Action time		Immediately acts	
Warning setting parameter		N/A	
Reset method		Cycle the power	
Reset condition		N/A	
Record		N/A	
Cause		<b>Corrective Actions</b>	
Poor connection of the cable		Re-connect the cable	
Bad quality of the cable		Replace the cable	

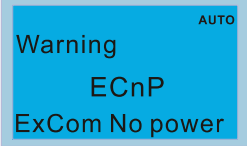

ID No.	Display on LCM Keypad	Warning Name	Description
74		ExCom no power (ECnP)	There is no power supply on the DeviceNet
<b>Action and Reset</b>			
Action level		There is no power supply on the DeviceNet	
Action time		Immediately acts	
Warning setting parameter		N/A	
Reset method		Re-power	
Reset condition		N/A	
Record		N/A	
Cause		<b>Corrective Actions</b>	
The drive detects that DeviceNet has no power		Check if the cable and power is normal. If yes, return to the factory for repair.	

ID No.	Display on LCM Keypad	Warning Name	Description
75		ExCom factory defect (ECFF)	Factory default setting error
<b>Action and Reset</b>			
Action level		Factory default setting error	
Action time		Immediately acts	
Warning setting parameter		N/A	
Reset method		Cycle the power	
Reset condition		N/A	
Record		N/A	
Cause		<b>Corrective Actions</b>	
Factory default setting error		Use DCISoft to reset to the default value.	

ID No.	Display on LCM Keypad	Warning Name	Description
76		ExCom inner error (ECiF)	Serious internal error
<b>Action and Reset</b>			
Action level		Internal memory saving error	
Action time		Immediately acts	
Warning setting parameter		N/A	
Reset method		Cycle the power	
Reset condition		N/A	
Record		N/A	
Cause		<b>Corrective Actions</b>	
Noise interference		Verify wiring of the control circuit, and wiring/grounding of the main circuit to prevent interference. Cycle the power.	
The memory is broken		Reset to the default value and check if the error still exists. If yes, replace the communication card.	

ID No.	Display on LCM Keypad	Warning Name	Description
77	Warning ECio ExCom IONet brk	ExCom IO Net break (ECio)	IO connection break off
<b>Action and Reset</b>			
Action level		IO connection between the communication card and the master is broken off	
Action time		Immediately acts	
Warning setting parameter		N/A	
Reset method		Manual reset	
Reset condition		Immediately reset	
Record		N/A	
Cause		<b>Corrective Actions</b>	
The cable is loose		Re-install the cable	
Incorrect parameter setting for master communication		Check the setting for master communication parameter	

ID No.	Display on LCM Keypad	Warning Name	Description
78	Warning ECPP ExCom Pr data	ExCom Parameter data error (ECPP)	Profibus parameter data error
<b>Action and Reset</b>			
Action level		N/A	
Action time		N/A	
Warning setting parameter		N/A	
Reset method		Manual reset	
Reset condition		Immediately reset	
Record		N/A	
Cause		<b>Corrective Actions</b>	
The GSD file is incorrect		Get the correct GSD file from the software	

ID No.	Display on LCM Keypad	Warning Name	Description
79	Warning ECPi ExCom Conf data	ExCom configuration data error (ECPi)	Profibus configuration data error
<b>Action and Reset</b>			
Action level		N/A	
Action time		N/A	
Warning setting parameter		N/A	
Reset method		Manual reset	
Reset condition		Immediately reset	
Record		N/A	
Cause		<b>Corrective Actions</b>	
The GSD file is incorrect		Get the correct GSD file from the software	

ID No.	Display on LCM Keypad	Warning Name	Description
80	Warning ECEF ExCom Link fail	Ethernet link fail (ECEF)	Ethernet cable is not connected
<b>Action and Reset</b>			
Action level		Hardware detection	
Action time		Immediately acts	
Warning setting parameter		N/A	
Reset method		Manual reset	
Reset condition		N/A	
Record		N/A	
Cause		<b>Corrective Actions</b>	
Ethernet cable is loose		Re-connect the cable	
Bad quality of Ethernet cable		Replace the cable	

ID No.	Display on LCM Keypad	Warning Name	Description
81	Warning ECto ExCom Inr T-out	Communication time-out (ECto)	Communication time-out for communication card and the upper unit
<b>Action and Reset</b>			
Action level		N/A	
Action time		N/A	
Warning setting parameter		N/A	
Reset method		N/A	
Reset condition		CMC-EC01: auto resets when the communication with the upper unit is back to normal	
Record		N/A	
Cause		<b>Corrective Actions</b>	
Communication card is not connected with the upper unit		Check if the connection of the communication cable is correct	
Communication error of the upper unit		Check if the communication of the upper unit is normal	

ID No.	Display on LCM Keypad	Warning Name	Description
82	Warning ECCS ExCom Inr CRC	Checksum error (ECCS)	Checksum error for communication card and the drive
<b>Action and Reset</b>			
Action level		Software detection	
Action time		N/A	
Warning setting parameter		N/A	
Reset method		Manual reset	
Reset condition		Immediately resets	
Record		N/A	
Cause		<b>Corrective Actions</b>	
Noise interference		Verify wiring of the control circuit, and wiring/grounding of the main circuit to prevent interference.	

ID No.	Display on LCM Keypad	Warning Name	Description
83	Warning E CrF ExCom Rtn def	Return defect (ECrF)	Communication card returns to the default setting
Action and Reset			
Action level		Communication card returns to the default setting	
Action time		N/A	
Warning setting parameter		N/A	
Reset method		Manual reset	
Reset condition		Immediately resets	
Record		N/A	
Cause		Corrective Actions	
Communication card is returning to default setting		No actions.	

ID No.	Display on LCM Keypad	Warning Name	Description
84	Warning E Co0 ExCom MTCP over	Modbus TCP over (Eco0)	MODBUS TCP exceeds maximum communication value
Action and Reset			
Action level		Hardware detection	
Action time		Immediately acts	
Warning setting parameter		N/A	
Reset method		Manual reset	
Reset condition		Immediately resets	
Record		N/A	
Cause		Corrective Actions	
The Master communication value is more than the allowable quantity of the communication card		Reduce Master communication value	
The upper unit is online without communicating, and does not break off the MODBUS TCP link, causes occupy connection		Revise program of upper unit, the communication should be break off when it is not used for a long time	
A new MODBUS TCP connection is built every time when the upper unit is connected to the communication card, which caused occupy connection		Revise program of upper unit: use the same MODBUS TCP connection when connected to the same communication card	

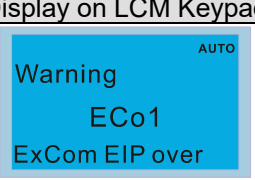
ID No.	Display on LCM Keypad	Warning Name	Description
85		EtherNet/IP over (ECo1)	Ethernet/IP exceeds maximum communication value
<b>Action and Reset</b>			
Action level		Hardware detection	
Action time		Immediately acts	
Warning setting parameter		N/A	
Reset method		Manual reset	
Reset condition		Immediately resets	
Record		N/A	
Cause		<b>Corrective Actions</b>	
The Master communication value is more than the allowable quantity of the communication card		Reduce Master communication value	
The upper unit is online without communicating, and does not break off the MODBUS TCP link, causes occupy connection		Revise program of upper unit, the communication should be break off when it is not used for a long time	
A new MODBUS TCP connection is built every time when the upper unit is connected to the communication card, which caused occupy connection		Revise program of upper unit: use the same MODBUS TCP connection when connected to the same communication card	

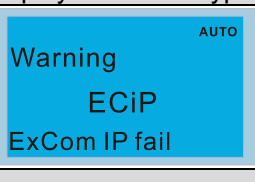
ID No.	Display on LCM Keypad	Warning Name	Description
86		IP fail (ECiP)	IP setting error
<b>Action and Reset</b>			
Action level		Software detection	
Action time		Immediately acts	
Warning setting parameter		N/A	
Reset method		Manual reset	
Reset condition		Immediate reset	
Record		N/A	
Cause		<b>Corrective Actions</b>	
IP conflict		Reset IP	
DHCP IP configuration error		MIS check if DHCP Server works normally	

ID No.	Display on LCM Keypad	Warning Name	Description
87	Warning EC3F ExCom Mail fail	Mail fail (EC3F)	Mail warning: Alarm mail will be sent when the communication card establishes alarm conditions
<b>Action and Reset</b>			
Action level		Communication card establishes alarm conditions	
Action time		Immediately acts	
Warning setting parameter		N/A	
Reset method		Manual reset	
Reset condition		Immediately resets	
Record		N/A	
Cause		<b>Corrective Actions</b>	
Communication card establishes alarm conditions		No actions	

ID No.	Display on LCM Keypad	Warning Name	Description
88	Warning Ecby ExCom Busy	ExCom busy (ECbY)	Communication card busy: too much packets are received
<b>Action and Reset</b>			
Action level		Software detection	
Action time		N/A	
Warning setting parameter		N/A	
Reset method		Manual reset	
Reset condition		N/A	
Record		N/A	
Cause		<b>Corrective Actions</b>	
Communication packets are too much for the communication card to process		Reduce communication packets	

ID No.	Display on LCM Keypad	Warning Name	Description
89	Warning ECCb ExCom Card break	ExCom card break (ECCb)	Communication card break off warning
<b>Action and Reset</b>			
Action level		Communication card break off	
Action time		The time between communication card break off and ECCb displays: 1. EtherNet/IP: 3 sec. 2. Modbus TCP: 3 sec. 3. DeviceNet: 1 sec. 4. PROFIBUS: 1 sec. 5. EtherCAT: 0.1 sec.	
Warning setting parameter		N/A	
Reset method		Auto resets after communication card is re-installed	
Reset condition		Immediately resets	
Record		N/A	
Cause		<b>Corrective Actions</b>	
Communication card break off		Re-install communication card	

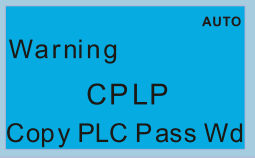
ID No.	Display on LCM Keypad	Warning Name	Description
90		Copy PLC: password error (CPLP)	Copy PLC password error. When KPC-CC01 is processing PLC copy and the PLC password is incorrect, the CPLP warning shows.
<b>Action and Reset</b>			
Action level		PLC password is incorrect	
Action time		Immediately acts	
Warning setting parameter		N/A	
Reset method		Manual reset	
Reset condition		Directly resets	
Record		N/A	
Cause		<b>Corrective Actions</b>	
PLC password is incorrect		Reset and enter correct PLC password	

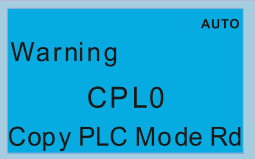
ID No.	Display on LCM Keypad	Warning Name	Description
91		Copy PLC: Read mode error (CPL0)	Copy PLC Read mode error
<b>Action and Reset</b>			
Action level		When copy PLC read mode with incorrect process	
Action time		Immediately acts	
Warning setting parameter		N/A	
Reset method		Manual reset	
Reset condition		Directly resets	
Record		N/A	
Cause		<b>Corrective Actions</b>	
When copy PLC read mode and the process is incorrect		Cycle the power and copy PLC read mode again	

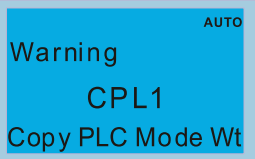
ID No.	Display on LCM Keypad	Warning Name	Description
92		Copy PLC: Write mode (CPL1)	Copy PLC write mode error
<b>Action and Reset</b>			
Action level		Copy PLC write mode with incorrect process	
Action time		Immediately acts	
Warning setting parameter		N/A	
Reset method		Manual reset	
Reset condition		Directly resets	
Record		N/A	
Cause		<b>Corrective Actions</b>	
When copy PLC write mode and the process is incorrect		Cycle the power and copy PLC read mode again	

ID No.	Display on LCM Keypad	Warning Name	Description
93	Warning CPLv Copy PLC Version	Copy PLC: version error (CPLv)	Copy PLC version error. When non-C2000 built-in PLC is copied to C2000 drive, the CPLv warning shows
Action and Reset			
Action level		Software detection	
Action time		Immediately acts	
Warning setting parameter		N/A	
Reset method		Manual reset	
Reset condition		Directly resets	
Record		N/A	
Cause		Corrective Actions	
Non-C2000 PLC program is copied to C2000		Check if the copied PLC program is for C2000. Use the correct C2000 PLC program.	

ID No.	Display on LCM Keypad	Warning Name	Description
94	Warning CPLS Copy PLC Size	Copy PLC: size error (CPLS)	Copy PLC Capacity size error
Action and Reset			
Action level		Software detection	
Action time		Immediately acts	
Warning setting parameter		N/A	
Reset method		Manual reset	
Reset condition		Directly resets	
Record		N/A	
Cause		Corrective Actions	
The PLC copied to C2000 exceeds the allowable capacity		Check if the copied PLC program is for C2000 Use C2000 PLC program with correct capacity	

ID No.	Display on LCM Keypad	Warning Name	Description
95	Warning CPLF Copy PLC Func	Copy PLC: PLC function (CPLF)	KPC-CC01 Copy PLC function should be executed when PLC is off
Action and Reset			
Action level		Software detection	
Action time		Immediately acts	
Warning setting parameter		N/A	
Reset method		Manual reset	
Reset condition		Directly resets	
Record		N/A	
Cause		Corrective Actions	
PLC function is enabled when KPC-CC01 is running copy PLC		Disable PLC function first, then run the PLC copy function again	

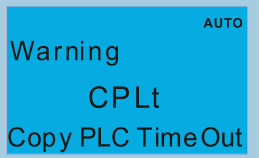

ID No.	Display on LCM Keypad	Warning Name	Description
96		Copy PLC: time-out (CPLt)	Copy PLC time out
<b>Action and Reset</b>			
Action level		Software detection	
Action time		Immediately acts	
Warning setting parameter		N/A	
Reset method		Manual reset	
Reset condition		Directly resets	
Record		N/A	
Cause		<b>Corrective Actions</b>	
KPC-CC01 is removed while copying PLC program		The KPC-CC01 cannot be removed during the PLC copy process	

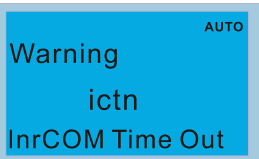
ID No.	Display on LCM Keypad	Warning Name	Description
101		InrCOM time-out (ictn)	Internal communication time-out
<b>Action and Reset</b>			
Action level		When Pr. 09-31=(-1) – (-10) (no -9) and the internal communication between Master and Slave is abnormal, the ictn warning shows.	
Action time		Immediately acts	
Warning setting parameter		N/A	
Reset method		Auto-reset	
Reset condition		The warning automatically clears when the communication is back to normal condition	
Record		N/A	
Cause		<b>Corrective Actions</b>	
Malfunction caused by interference		Verify wiring/grounding of the communication circuit. It is recommended to separate the communication circuit from the main circuit, or wire in 90 degree for effective anti-interference performance.	
Different communication conditions with the upper unit		Check if the setting for Pr. 09-02 is the same as the setting for upper unit	
Communication cable break off or not connected well		Check the cable status or replace the cable	

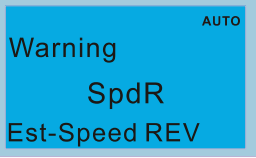
ID No.	Display on LCM Keypad	Warning Name	Description
105		Estimated speed reverse (SpdR)	Estimated speed is in a reverse direction with motor actual running direction
<b>Action and Reset</b>			
Action level		Software detection	
Action time		Pr. 10-09	
Warning setting parameter		Pr. 10-08 0: Warn and keep operation 1: Warn and coast to stop 2: Warn and ramp to stop	
Reset method		Manual reset	
Reset condition		Immediately resets	
Record		N/A	
Cause		<b>Corrective Actions</b>	
The motor runs in reverse direction at start		Check if the motor is hold when started, or start the motor with speed source.	
The difference between motor parameter measured Rr and Rs value is too large		Normally the Rr value of IM is Rs*0.7. If there is much difference of the measured value (e.g. Rr=Rs*0.3), proceed the motor parameter auto-tuning again.	
Insufficient output torque is dragged to the reverse direction by the load.		Increase the current limit of Pr. 06-12, so as to increase the output torque.	

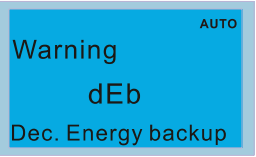
ID No.	Display on LCM Keypad	Warning Name	Description
123		Deceleration energy backup (dEb)	Deceleration energy backup
<b>Action and Reset</b>			
Action level		Software detection	
Action time		N/A	
Warning setting parameter		0: Disable 1: dEb with auto accel./decel., the output frequency will not return after power reply. 2: dEb with auto accel./decel., the output frequency will return after power reply. 3: dEb low-voltage control, then increase to 350V <sub>DC</sub> /700V <sub>DC</sub> and decelerate to stop. 4: dEb high-voltage control of 350V <sub>DC</sub> /700V <sub>DC</sub> and decelerate to stop	
Reset method		Manual reset	
Reset condition		Immediately resets	
Record		N/A	
Cause		<b>Corrective Actions</b>	
Instantaneous power off or low voltage and unstable/ sudden heavy load of the power that cause the voltage drop		Check the power consumption	
Unexpected power off		Check the power consumption	

[This page intentionally left blank]

# Chapter 14 Fault Codes and Descriptions

① Warning	AUTO	① Display error signal
② ocA		② Abbreviate error code
③ Oc at accel		③ Display error description

\* : Refer to setting of Pr. 06-17–Pr. 06-22.

ID*	Display on LCM Keypad	Fault Name	Fault Descriptions
1		Over-current during acceleration (ocA)	Output current exceeds 2.4 times of rated current during acceleration. When ocA occurs, the drive closes the gate of the output immediately, the motor runs freely, and the display shows an ocA error.
<b>Action and Reset</b>			
	Action level	240% of rated current	
	Action time	Immediately act	
	Fault treatment parameter	N/A	
	Reset method	Manual reset	
	Reset condition	Reset in 5 sec. after the fault is cleared	
	Record	Yes	
	Cause	<b>Corrective Actions</b>	
	Acceleration time is too short	1. Increase the acceleration time 2. Increase the acceleration time of S curve 3. Set auto-acceleration and auto-deceleration parameter (Pr. 01-44) 4. Set over-current stall prevention function (Pr. 06-03) 5. Replace the drive with a larger capacity model.	
	Short circuit at motor output due to poor insulation wiring	Check the motor cable and remove causes of the short circuits, or replace the cable before turning on the power.	
	Check for possible burnout or aging insulation of the motor	Check the motor insulation value with megger. Replace the motor if the insulation is poor.	
	The load is too large.	Check if the output current during the whole working process exceeds the AC motor drive's rated current. If yes, replace the AC motor drive with a larger capacity model.	
	Impulsive change of the load	Reduce the load or increase the capacity of AC motor drive.	
	Use special motor or motor with larger capacity than the drive	Check the motor capacity (the rated current on the motor's nameplate should $\leq$ the rated current of the drive)	
	Use ON/OFF controller of an electromagnetic contactor at the output (U/V/W) of the drive	Check the action timing of the contactor and make sure it is not turned ON/OFF when the drive outputs the voltage.	
	V/F curve setting error	Adjust V/F curve setting and frequency/voltage. When the fault occurs, and the frequency voltage is too high, reduce the voltage.	
	Torque compensation is too large	Adjust the torque compensation (refer to Pr.07-26 torque compensation gain) until the output current reduces and the motor does not stall.	
	Malfunction caused by interference	Verify the wiring of the control circuit and wiring/grounding of the main circuit to prevent interference.	
	The motor starts when in free run	Enable the speed tracking during start-up of Pr. 07-12.	
	Improper parameter settings for the speed tracking function (including restart after momentary power loss and restart after fault)	Correct the parameter settings for speed tracking. 1. Start the speed tracking function. 2. Adjust the maximum current for Pr. 07-09 speed tracking.	
	Incorrect combination of control mode and used motor	Check the settings for Pr. 00-11 control mode: 1. For IM, Pr. 00-11=0, 1, 2, 3, 5 2. For PM, Pr. 00-11=4, 6, or 7	
	The length of motor cable is too long	Increase AC motor drive's capacity. Install AC reactor(s) on the output side (U/V/W).	

Hardware failure	<p>The ocA occurs due to short circuit or ground fault at the output side of the drive. Check for possible short circuits between terminals with the electric meter: B1 corresponds to U, V, W; DC- corresponds to U, V, W; ⊕ corresponds to U, V, W.</p> <p>If short circuit occur, return to the factory for repair.</p>
Check if the setting for stall prevention is correct	Set the stall prevention to the proper value.

ID*	Display on LCM Keypad	Fault Name	Fault Descriptions
2		Over-current during deceleration (ocd)	Output current exceeds 2.4 times of rated current during deceleration. When ocd occurs, the drive closes the gate of the output immediately, the motor runs freely, and the display shows an ocd error.
<b>Action and Reset</b>			
Action level		240% of rated current	
Action time		Immediately act	
Fault treatment parameter		N/A	
Reset method		Manual reset	
Reset condition		Reset in 5 sec. after the fault is cleared	
Record		Yes	
<b>Cause</b>		<b>Corrective Actions</b>	
Deceleration time too short		<ol style="list-style-type: none"> <li>1. Increase the deceleration time</li> <li>2. Increase the deceleration time of S-curve</li> <li>3. Set auto-acceleration and auto-deceleration parameter (Pr. 01-44)</li> <li>4. Set over-current stall prevention function (Pr. 06-03)</li> <li>5. Replace the drive with a larger capacity model</li> </ol>	
Check if the mechanical brake of the motor activates too early		Check the action timing of the mechanical brake	
Short-circuit at motor output due to poor insulation wiring		Check the motor cable and remove causes of the short circuits, or replace the cable before turning on the power.	
Check for possible burnout or aging insulation of the motor		Check the motor insulation value with megger. Replace the motor if the insulation is poor.	
The load is too large		Check if the output current during the whole working process exceeds the AC motor drive's rated current. If yes, replace the AC motor drive with a larger capacity model.	
Impulsive change of the load		Reduce the load or increase the capacity of AC motor drive.	
Use special motor or motor with larger capacity than the drive		Check the motor capacity (the rated current on the motor's nameplate should $\leq$ the rated current of the drive)	
Use ON/OFF controller of an electromagnetic contactor at the output (U/V/W) of the drive		Check the action timing of the contactor and make sure it is not turned ON/OFF when the drive outputs the voltage.	
V/F curve setting error		Adjust V/F curve settings and frequency/voltage. When the fault occurs, and the frequency voltage is too high, reduce the voltage.	
Torque compensation is too large		Adjust the torque compensation (refer to Pr.07-26 torque compensation gain) until the output current reduces and the motor does not stall.	
Malfunction caused by interference		Verify the wiring of the control circuit and wiring/grounding of the main circuit to prevent interference.	
The length of motor cable is too long		Increase AC motor drive's capacity Install AC reactor(s) on the output side (U/V/W)	
Hardware error		The ocd occurs due to short circuit or ground fault at the output side of the drive. Check for possible short circuits between terminals with the electric meter: B1 corresponds to U, V, W; DC- corresponds to U, V, W; $\oplus$ corresponds to U, V, W. If short circuits occur, return to the factory for repair.	
Check if the setting of stall prevention is correct		Set the stall prevention to the proper value.	

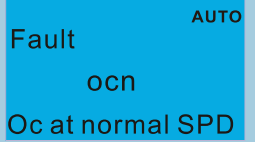
ID*	Display on LCM Keypad	Fault Name	Fault Descriptions
3		Over-current during steady operation (ocn)	Output current exceeds 2.4 times of the rated current during constant speed. When ocn occurs, the drive closes the gate of the output immediately, the motor runs freely, and the display shows an ocn error.
<b>Action and Reset</b>			
Action level		240% of rated current	
Action time		Immediately act	
Fault treatment parameter		N/A	
Reset method		Manual reset	
Reset condition		Reset in 5 sec. after the fault is cleared	
Record		Yes	
<b>Cause</b>		<b>Corrective Actions</b>	
Short-circuit at motor output due to poor insulation wiring		Check the motor cable and remove causes of the short circuits, or replace the cable before turning on the power.	
Check for possible shaft lock, burnout or aging insulation of the motor		Troubleshoot the motor shaft lock. Check the motor insulation value with megger. Replace the motor if the insulation is poor.	
Impulsive change of the load		Reduce the load or increase the capacity of AC motor drive.	
Use special motor or motor with larger capacity than the drive		Check motor capacity (the rated current on the motor's nameplate should $\leq$ the rated current of the drive)	
Use ON/OFF controller of an electromagnetic contactor at the output (U/V/W) of the drive		Check the action timing of the contactor and make sure it is not turned ON/OFF when the drive outputs the voltage.	
V/F curve setting error		Adjust V/F curve settings and frequency/voltage. When the fault occurs, and the frequency voltage is too high, reduce the voltage.	
Over-torque offset value too high		Adjust over-torque offset value (Refer to Pr. 07-26 torque compensation gain), until the output current is reduced and not motor stall.	
Torque compensation is too large.		Adjust the torque compensation (refer to Pr.07-26 torque compensation gain) until the output current reduces and the motor does not stall.	
Malfunction caused by interference		Verify the wiring of the control circuit and wiring/grounding of the main circuit to prevent interference.	
The length of motor cable is too long		Increase the AC motor drive's capacity. Install AC reactor(s) on the output side (U/V/W).	
Hardware failure		The ocn occurs due to short circuit or ground fault at the output side of the drive. Check for possible short circuit between terminals with the electric meter: B1 corresponds to U, V, W; DC- corresponds to U, V, W; $\oplus$ corresponds to U, V, W. If short circuits occur, return to the factory for repair.	

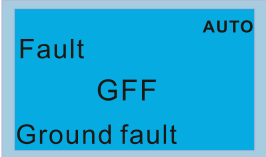
ID*	Display on LCM Keypad	Fault Name	Fault Descriptions
4		Ground fault (GFF)	When (one of) the output terminal(s) is grounded, short circuit current is larger than Pr. 06-60 setting value, and the detection time is longer than Pr. 06-61 time setting, GFF occurs. NOTE: the short circuit protection is provided for AC motor drive protection, not to protect the user.
<b>Action and Reset</b>			
Action level		Pr. 06-60 (Default = 60%)	
Action time		Pr. 06-61 (Default = 0.10 sec.)	
Fault treatment parameter		N/A	
Reset method		Manual reset	
Reset condition		Reset in 5 sec. after the fault is cleared	
Record		Yes	
Cause		<b>Corrective Actions</b>	
Motor burnout or aging insulation occurred		Check the motor insulation value with megger. Replace the motor if the insulation is poor.	
Short circuit due to broken cable		Troubleshoot the short circuit. Replace the cable.	
Larger stray capacitance of the cable and terminal $\oplus$		If the motor cable length exceeds 100m, decrease the setting value for carrier frequency. Take remedies to reduce stray capacitance.	
Malfunction caused by interference		Verify the grounding and wiring of the communication circuit. It is recommended to separate the communication circuit from the main circuit, or wire in 90 degree for effective sufficient anti-interference performance.	
Hardware failure		Cycle the power after checking the status of motor, cable and cable length. If GFF still exists, return to the factory for repair.	

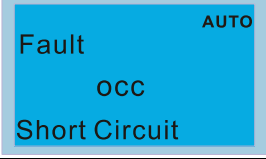
ID*	Display on LCM Keypad	Fault Name	Fault Descriptions
5		IGBT short circuit between upper bridge and lower bridge (occ)	Short-circuit is detected between upper bridge and lower bridge of the IGBT module
<b>Action and Reset</b>			
Action level		Hardware protection	
Action time		Immediately act	
Fault treatment parameter		N/A	
Reset method		Manual reset	
Reset condition		Reset in 5 sec. after the fault is cleared	
Record		Yes	
Cause		<b>Corrective Actions</b>	
IGBT error		Check the motor wiring.	
Short-circuit detecting circuit error		Cycle the power, if occ still exists, return to the factory for repair.	

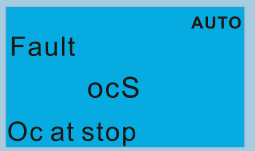

ID*	Display on LCM Keypad	Fault Name	Fault Descriptions
6		Over-current at stop (ocS)	Over-current or hardware failure in current detection at stop. Cycle the power after ocS occurs. If the hardware failure occurs, the display shows cd1, cd2 or cd3.
<b>Action and Reset</b>			
Action level		240% of rated current	
Action time		Immediately act	
Fault treatment parameter		N/A	
Reset method		Manual reset	
Reset condition		Reset in 5 sec. after the fault is cleared	
Record		Yes	
Cause		<b>Corrective Actions</b>	
Malfunction caused by interference		Verify the wiring of the control circuit and wiring/grounding of the main circuit to prevent interference.	
Hardware failure		Check if other error code such as cd1–cd3 occur after cycling the power. If yes, return to the factory for repair.	

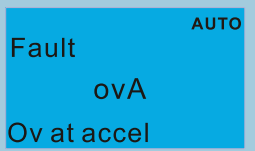
ID*	Display on LCM Keypad	Fault Name	Fault Descriptions
7		Over-voltage during acceleration (ovA)	DC BUS over-voltage during acceleration. When ovA occurs, the drive closes the gate of the output, the motor runs freely, and the display shows an ovA error.
<b>Action and Reset</b>			
Action level		230V series: 410V <sub>DC</sub> 460V series: 820V <sub>DC</sub> 575V series: 1116V <sub>DC</sub> 690V series: 1318V <sub>DC</sub>	
Action time		Immediately act when DC BUS voltage is higher than the level	
Fault treatment parameter		N/A	
Reset method		Manual reset	
Reset condition		Reset only when DC BUS voltage is lower than 90% of the over-voltage level	
Record		Yes	
Cause		<b>Corrective Actions</b>	
Acceleration is too slow (e.g. when lifting load decreases acceleration time)		Decrease the acceleration time Use brake unit or DC BUS Replace the drive with a larger capacity model.	
The setting for stall prevention level is smaller than no-load current		The setting for stall prevention level should be larger than no-load current	
Power voltage is too high		Check if the input voltage is within the rated AC motor drive input voltage range, and check for possible voltage spikes.	
ON/OFF switch action of phase-in capacitor in the same power system		If the phase-in capacitor or active power supply unit acts in the same power system, the input voltage may surge abnormally in a short time. In this case, install an AC reactor.	
Regenerative voltage of motor inertia		Use over-voltage stall prevention function (Pr. 06-01) Use auto-acceleration and auto-deceleration setting (Pr. 01-44) Use a brake unit or DC BUS	
Acceleration time is too short		Check if the over-voltage warning occurs after acceleration stops. When the warning occurs, do the following: 1. Increase the acceleration time 2. Set Pr. 06-01 over-voltage stall prevention 3. Increase setting value for Pr. 01-25 S-curve acceleration arrival time 2	
Motor ground fault		The ground short circuit current charges the capacitor in the main circuit through the power. Check if there is ground fault on the motor cable, wiring box and its internal terminals. Troubleshoot the ground fault.	
Incorrect wiring of brake resistor or brake unit		Check the wiring of brake resistor and brake unit.	
Malfunction caused by interference		Verify the wiring of the control circuit and wiring/grounding of the main circuit to prevent interference.	

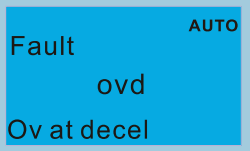
ID*	Display on LCM Keypad	Fault Name	Fault Descriptions
8		Over-voltage during deceleration (ovd)	DC BUS over-voltage during deceleration. When ovd occurs, the drive closes the gate of the output immediately, the motor runs freely, and the display shows an ovd error.
<b>Action and Reset</b>			
Action level	230V series: 410V <sub>DC</sub> 460V series: 820V <sub>DC</sub> 575V series: 1116V <sub>DC</sub> 690V series: 1318V <sub>DC</sub>		
Action time	Immediately act when DC BUS voltage is higher than the level		
Fault treatment parameter	N/A		
Reset method	Manual reset		
Reset condition	Reset only when DC BUS voltage is lower than 90% of the over-voltage level		
Record	Yes		
Cause	<b>Corrective Actions</b>		
Deceleration time is too short, causing too large regenerative energy of the load	<ol style="list-style-type: none"> <li>1. Increase the setting value of Pr. 01-13, Pr. 01-15, Pr. 01-17 and Pr. 01-19 (deceleration time)</li> <li>2. Connect brake resistor, brake unit or DC BUS on the drive.</li> <li>3. Reduce the brake frequency.</li> <li>4. Replace the drive with a larger capacity model.</li> <li>5. Use S-curve acceleration/deceleration.</li> <li>6. Use over-voltage stall prevention (Pr. 06-01).</li> <li>7. Use auto-acceleration and auto-deceleration (Pr. 01-44).</li> <li>8. Adjust braking level (Pr. 07-01 or the bolt position of the brake unit).</li> </ol>		
The setting for stall prevention level is smaller than no-load current	The setting for stall prevention level should be larger than no-load current		
Power voltage is too high	Check if the input voltage is within the rated AC motor drive input voltage range, and check for possible voltage spikes.		
ON/OFF switch action of phase-in capacitor in the same power system	If the phase-in capacitor or active power supply unit acts in the same power system, the input voltage may surge abnormally in a short time. In this case, install an AC reactor.		
Motor ground fault	The ground short circuit current charges the capacitor in the main circuit through the power. Check if there is ground fault on the motor cable, wiring box and its internal terminals. Troubleshoot the ground fault.		
Incorrect wiring of brake resistor or brake unit	Check the wiring of brake resistor or brake unit.		
Malfunction caused by interference	Verify the wiring of the control circuit and wiring/grounding of the main circuit to prevent interference.		

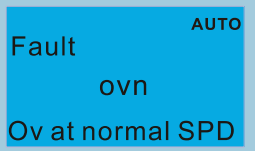
ID*	Display on LCM Keypad	Fault Name	Fault Descriptions
9		Over-voltage at constant speed (ovn)	DC BUS over-voltage at constant speed. When ovn occurs, the drive closes the gate of the output immediately, the motor runs freely, and the display shows an ovn error.
<b>Action and Reset</b>			
Action level	230V series: 410V <sub>DC</sub> 460V series: 820V <sub>DC</sub> 575V series: 1116V <sub>DC</sub> 690V series: 1318V <sub>DC</sub>		
Action time	Immediately act when DC BUS voltage is higher than the level		
Fault treatment parameter	N/A		
Reset method	Manual reset		
Reset condition	Reset only when DC BUS voltage is lower than 90% of over-voltage level		
Record	Yes		
Cause	<b>Corrective Actions</b>		
Impulsive change of the load	<ol style="list-style-type: none"> <li>1. Connect brake resistor, brake unit or DC BUS to the drive.</li> <li>2. Reduce the load.</li> <li>3. Replace to drive with a larger capacity model.</li> <li>4. Adjust braking level (Pr. 07-01 or bolt position of the brake unit).</li> </ol>		
The setting for stall prevention level is smaller than no-load current	The setting of stall prevention level should be larger than no-load current		
Regenerative voltage of motor inertia	Use over-voltage stall prevention function (Pr. 06-01) Use a brake unit or DC BUS		
Power voltage is too high	Check if the input voltage is within the rated AC motor drive input voltage range, and check for possible voltage spikes.		
ON/OFF switch action of phase-in capacitor in the same power system	If the phase-in capacitor or active power supply unit acts in the same power system, the input voltage may surge abnormally in a short time. In this case, install an AC reactor.		
Motor ground fault	The ground short-circuit current charges the capacitor in the main circuit through the power. Check if there is ground fault on the motor cable, wiring box and its internal terminals. Troubleshoot the ground fault.		
Incorrect wiring of brake resistor or brake unit	Check the wiring of brake resistor or brake unit.		
Malfunction caused by interference	Verify the wiring of the control circuit and wiring/grounding of the main circuit to prevent interference.		

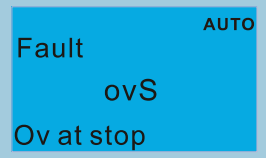
ID*	Display on LCM Keypad	Fault Name	Fault Descriptions
10		Over-voltage at stop (ovS)	Over-voltage at stop
<b>Action and Reset</b>			
Action level	230V series: 410V <sub>DC</sub> 460V series: 820V <sub>DC</sub> 575V series: 1116V <sub>DC</sub> 690V series: 1318V <sub>DC</sub>		
Action time	Immediately act when DC BUS voltage is higher than the level		
Fault treatment parameter	N/A		
Reset method	Manual reset		
Reset condition	Reset only when DC BUS voltage is lower than 90% of over-voltage level		
Record	Yes		
Cause	<b>Corrective Actions</b>		
Power voltage is too high	Check if the input voltage is within the rated AC motor drive input voltage range, and check for possible voltage spikes.		
ON/OFF switch action of phase-in capacitor in the same power system	If the phase-in capacitor or active power supply unit activates in the same power system, the input voltage may surge abnormally in a short time. In this case, install an AC reactor.		
Incorrect wiring of brake resistor or brake unit	Check the wiring of brake resistor or brake unit.		
Malfunction caused by interference	Verify the wiring of the control circuit and wiring/grounding of the main circuit to prevent interference.		
Hardware failure in voltage detection	Check if other error code such as cd1–cd3 occur after cycling the power. If yes, return to the factory for repair.		
Motor ground fault	The ground short circuit current charges the capacitor in the main circuit through the power. Check if there is ground fault on the motor cable, wiring box and its internal terminals. Troubleshoot the ground fault.		

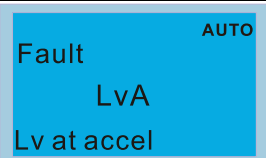
ID*	Display on LCM Keypad	Fault Name	Fault Descriptions
11		Low-voltage during acceleration (LvA)	DC BUS voltage is lower than Pr. 06-00 setting value during acceleration
<b>Action and Reset</b>			
Action level	Pr. 06-00 (Default = depending on the model)		
Action time	Immediately act when DC BUS voltage is lower than Pr. 06-00		
Fault treatment parameter	N/A		
Reset method	Manual reset		
Reset condition	Reset when DC BUS voltage is higher than Pr. 06-00 + 30V (Frame A–D) / 40V (Frame E and below)		
Record	Yes		
Cause	<b>Corrective Actions</b>		
Power-off	Improve power supply condition.		
Power voltage changes	Adjust voltage to the power range of the drive		
Start up the motor with large capacity	Check the power system. Increase the capacity of power equipment.		
The load is too large	Reduce the load. Increase the drive capacity. Increase the acceleration time.		
DC BUS	Install DC reactor(s).		
Check if there is short-circuit plate or any DC reactor installed between terminal +1 and +2	Connect short circuit plate or DC reactor between terminal +1 and +2. If the error still exists, return to the factory for repair.		

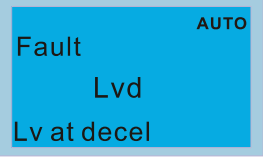
ID*	Display on LCM Keypad	Fault Name	Fault Descriptions
12		Low-voltage during deceleration (Lvd)	DC BUS voltage is lower than Pr. 06-00 setting value during deceleration
<b>Action and Reset</b>			
Action level		Pr. 06-00 (Default = depending on the model)	
Action time		Immediately act when DC BUS voltage is lower than Pr. 06-00	
Fault treatment parameter		NA	
Reset method		Manual reset	
Reset condition		Reset when DC BUS voltage is higher than Pr. 06-00 + 30V (Frame A–D) / 40V (Frame E and above)	
Record		Yes	
<b>Cause</b>		<b>Corrective Actions</b>	
Power-off		Improve power supply condition.	
Power voltage changes		Adjust voltage to the power range of the drive.	
Start up the motor with large capacity		Check the power system. Increase the capacity of power equipment.	
Sudden load		Reduce the load. Increase the drive capacity.	
DC BUS		Install DC reactor(s).	

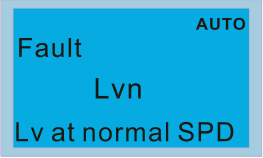
ID*	Display on LCM Keypad	Fault Name	Fault Descriptions
13		Low-voltage at constant speed (Lvn)	DC BUS voltage is lower than Pr. 06-00 setting value at constant speed
<b>Action and Reset</b>			
Action level		Pr. 06-00 (Default = depending on the model)	
Action time		Immediately act when DCBUS voltage is lower than Pr. 06-00	
Fault treatment parameter		NA	
Reset method		Manual reset	
Reset condition		Reset when DCBUS voltage is higher than Pr. 06-00 + 30V (Frame A–D) / 40V (Frame E and above)	
Record		Yes	
<b>Cause</b>		<b>Corrective Actions</b>	
Power-off		Improve power supply condition.	
Power voltage changes		Adjust voltage to the power range of the drive	
Start up the motor with large capacity		Check the power system. Increase the capacity of power equipment.	
Sudden load		Reduce the load. Increase the drive capacity.	
DC BUS		Install DC reactor(s).	

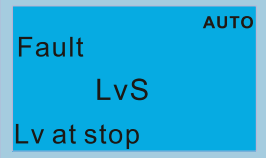
ID*	Display on LCM Keypad	Fault Name	Fault Descriptions
14		Low-voltage at stop (LvS)	<ol style="list-style-type: none"> <li>DC BUS voltage is lower than Pr. 06-00 setting value at stop</li> <li>Hardware failure in voltage detection</li> </ol>
<b>Action and Reset</b>			
Action level		Pr. 06-00 (Default = depending on the model)	
Action time		Immediately act when DCBUS voltage is lower than Pr. 06-00	
Fault treatment parameter		N/A	
Reset method		Manual/ auto 230V series: Frame A–D = Lv level + 30V <sub>DC</sub> + 500ms Frame E and above = Lv level + 40V <sub>DC</sub> + 500ms 460V series: Frame A–D = Lv level + 60V <sub>DC</sub> + 500ms Frame E and above = Lv level + 80V <sub>DC</sub> + 500ms 575V series: Frame A–D = Pr. 06-00 + 100.0V <sub>DC</sub> Frame E and above = Pr. 06-00 + 120.0V <sub>DC</sub> 690V series: Frame A–D = Pr. 06-00 + 100.0V <sub>DC</sub> Frame E and above = Pr. 06-00 + 100.0V <sub>DC</sub>	
Reset condition		500ms	
Record		Yes	
Cause		<b>Corrective Actions</b>	
Power-off		Improve power supply condition.	
Incorrect drive models		Check if the power specification matches the drive.	
Power voltage changes		Adjust voltage to the power range of the drive. Cycle the power after checking the power. If LvS error still exists, return to the factory for repair.	
Start up the motor with large capacity		Check the power system. Increase the capacity of power equipment.	
DC BUS		Install DC reactor(s).	

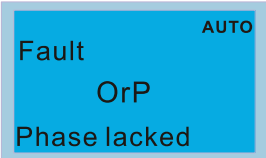
ID*	Display on LCM Keypad	Fault Name	Fault Descriptions
15		Phase loss protection (OrP)	Phase loss of power input
<b>Action and Reset</b>			
Action level		DC BUS is lower than Pr. 07-00, and DC BUS ripple is higher than Pr. 06-52	
Action time		N/A	
Fault treatment parameter		Pr. 06-53	
Reset method		Manual reset	
Reset condition		Immediately reset when DCBUS is higher than Pr. 07-00	
Record		Yes	
Cause		<b>Corrective Actions</b>	
Phase loss of input power		Correctly install the wiring of the main circuit power.	
Single phase power input to three-phase model		Choose the model whose power matches the voltage.	
Power voltage changes		If the main circuit power works normally, verify the main circuit. Cycle the power after checking the power, if OrP error still exists, return to the factory for repair.	
Loose wiring terminal of input power		Tighten the terminal screws according to the torque described in the user manual.	
The input cable of three-phase power is cut off		Wire correctly. Replace the cut off cable.	
Input power voltage changes too much		Verify the setting value for Pr. 06-50 Time for Input Phase Loss Detection and Pr. 06-52 Ripple of Input Phase Loss	
Unbalanced three-phase of input power		Check the power three-phase status.	

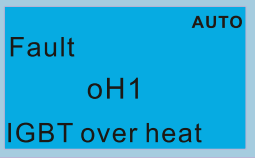
ID*	Display on LCM Keypad	Fault Name	Fault Descriptions
16		IGBT overheating (oH1)	IGBT temperature exceeds the protection level
<b>Action and Reset</b>			
Action level	When Pr.06-15 is higher than the IGBT overheating protection level, oH1 error occurs instead of oH1 warning.		
Action time	IGBT temperature exceeds the protection level for more than 100ms, oH1 error occurs.		
Fault treatment parameter	N/A		
Reset method	Manual reset		
Reset condition	Reset only when IGBT temperature is lower than oH1 error level minus (-) 10°C		
Record	Yes		
<b>Cause</b>	<b>Corrective Actions</b>		
Check if the ambient temperature or temperature inside the control cabinet is too high, or if there is obstruction in the ventilation hole of the control cabinet.	<ol style="list-style-type: none"> <li>1. Check ambient temperature.</li> <li>2. Regularly inspect the ventilation hole of the control cabinet.</li> <li>3. Change the installed place if there are heating objects, such as braking resistors, in the surroundings.</li> <li>4. Install/ add cooling fan or air conditioner to lower the temperature inside the cabinet.</li> </ol>		
Check if there is any obstruction on the heat sink or if the fan is running.	Remove the obstruction or replace the cooling fan.		
Insufficient ventilation space	Increase ventilation space of the drive.		
Check if the drive matches the corresponding load	<ol style="list-style-type: none"> <li>1. Reduce the load</li> <li>2. Reduce the carrier</li> <li>3. Replace the drive with a larger capacity model.</li> </ol>		
The drive has run 100% or more than 100% of the rated output for a long time	Replace the drive with a larger capacity model.		

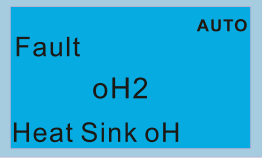
ID*	Display on LCM Keypad	Fault Name	Fault Descriptions
17		Heatsink overheating (oH2)	Capacitance temperature exceeds the protection level
<b>Action and Reset</b>			
Action level		Refer to the table below for oH2 level of each models	
Action time		When capacitance temperature exceeds the protection level for more than 100ms, oH2 error occurs	
Fault treatment parameter		N/A	
Reset method		Manual reset	
Reset condition		Reset when capacitance temperature is lower than oH2 error level minus (-) 10°C	
Record		Yes	
Cause		<b>Corrective Actions</b>	
Check if the ambient temperature or temperature inside the control cabinet is too high, or if there is obstruction in the ventilation hole of the control cabinet.		<ol style="list-style-type: none"> <li>1. Check ambient temperature.</li> <li>2. Regularly inspect the ventilation hole of the control cabinet.</li> <li>3. Change the installed place if there are heating objects, such as braking resistors, in the surroundings.</li> <li>4. Install/ add cooling fan or air conditioner to lower the temperature inside the cabinet.</li> </ol>	
Check if there is any obstruction on the heat sink or if the fan is running.		Remove the obstruction or replace the cooling fan.	
Insufficient ventilation space		Increase ventilation space of the drive.	
Check if the drive matches the corresponding load		<ol style="list-style-type: none"> <li>1. Reduce the load</li> <li>2. Reduce the carrier</li> <li>3. Replace the drive with a larger capacity model.</li> </ol>	
The drive has run 100% or more than 100% of the rated output for a long time		Replace the drive with a larger capacity model.	
Unstable power		Install reactor(s)	
Load changes frequently		Reduce load changes	

## oH1/ oH2 warning level

Model	oH1	oH2	oH warning oH1 warning = (Pr.06-15)
VFD007C23A	110	95	oH1 Warning = oH1 – 5 oH2 Warning = oH2 – 5
VFD015C23A			
VFD022C23A			
VFD037C23A		100	
VFD055C23A			
VFD075C23A		80	
VFD110C23A			
VFD150C23A			
VFD185C23A		75	
VFD220C23A			
VFD300C23A/E		65	
VFD370C23A/E			
VFD450C23A/E			
VFD550C23A/E			
VFD750C23A/E			
VFD900C23A/E			
VFD007C43A/E	110	95	oH1 Warning = oH1 – 5 oH2 Warning = oH2 – 5
VFD015C43A/E			
VFD022C43A/E		100	
VFD037C43A/E			
VFD040C43A/E		105	
VFD055C43A/E			
VFD075C43A/E		100	
VFD110C43A/E			
		80	

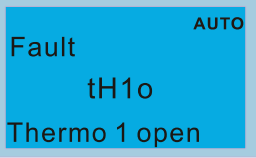

Model	oH1	oH2	oH warning oH1 warning = (Pr.06-15)	
VFD150C43A/E	110	80	oH1 Warning = oH1 – 5 oH2 Warning = oH2 – 5	
VFD185C43A/E		85		
VFD220C43A/E				
VFD300C43A/E				
VFD370C43S/U				
VFD450C43S/U				
VFD550C43A/E				
VFD750C43A/E				
VFD900C43A/E				
VFD1100C43A/E				
VFD1320C43A/E				
VFD1600C43A/E				
VFD1850C43A/E				
VFD2200C43A/E				
VFD2800C43A/E				70
VFD3150C43A/E				
VFD3550C43A/E				
VFD4500C43A/E				
VFD015C53A	100		85	oH1 Warning = oH1 – 5 oH2 Warning = oH2 – 5
VFD022C53A	105			
VFD037C53A	100	70		
VFD055C53A				
VFD075C53A				
VFD110C53A				
VFD150C53A				
VFD185C63B	90	85	oH1 Warning = oH1 – 5 oH2 Warning = oH2 – 5	
VFD220C63B				
VFD300C63B				
VFD370C63B				
VFD450C63B	100	65		
VFD550C63B				
VFD750C63B	110			
VFD900C63B				
VFD1100C63B				
VFD1320C63B				
VFD1600C63B				
VFD2000C63B				
VFD2500C63B				
VFD3150C63B				70
VFD4000C63B				
VFD4500C63B				
VFD5600C63B				
VFD6300C63B				

ID*	Display on LCM Keypad	Fault Name	Fault Descriptions
18		IGBT temperature detection failure (tH1o)	IGBT hardware failure in temperature detection
<b>Action and Reset</b>			
Action level		NTC broken or wiring failure	
Action time		When the IGBT temperature is higher than the protection level, and detection time exceeds 100ms, the tH1o protection activates.	
Fault treatment parameter		N/A	
Reset method		Manual reset	
Reset condition		Immediately reset	
Record		Yes	
Cause		<b>Corrective Actions</b>	
Hardware failure		Wait for 10 minutes, and then cycle the power. Check if tH1o protection still exists. If yes, return to the factory for repair.	

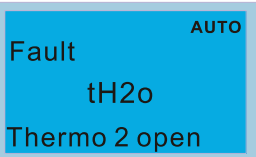
ID*	Display on LCM Keypad	Fault Name	Fault Descriptions
19		Capacitor hardware error (tH2o)	Hardware failure in capacitor temperature detection
<b>Action and Reset</b>			
Action level		NTC broken or wiring failure	
Action time		When the IGBT temperature is higher than the protection level, and detection time exceeds 100ms, the tH2o protection activates.	
Fault treatment parameter		N/A	
Reset method		Manual reset	
Reset condition		Immediately reset	
Record		Yes	
Cause		<b>Corrective Actions</b>	
Hardware failure		Wait for 10 minutes, and then cycle the power. Check if tH2o protection still exists. If yes, return to the factory for repair.	

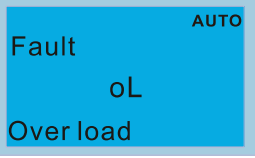
ID*	Display on LCM Keypad	Fault Name	Fault Descriptions
21		Over load (oL)	The AC motor drive detects excessive drive output current. The overload capacity sustains for 1 minute when the drive outputs 120% of the drive's rated output current.
<b>Action and Reset</b>			
Action level		Based on over load curve and derating curve.	
Action time		When the load is higher than the protection level and exceeds allowable time, the oL protection activates.	
Fault treatment parameter		N/A	
Reset method		Manual reset	
Reset condition		Reset in 5 sec. after the fault is cleared	
Record		Yes	
<b>Cause</b>		<b>Corrective Actions</b>	
The load is too large		Reduce the load	
Accel./Decel. time or the working cycle are too short		Increase the setting value for Pr. 01-12-01-19 (accel./decel time)	
V/F voltage is too high		Adjust the settings for Pr.01-01-01-08 (V/F curve), especially the setting value for the mid-point voltage (if the mid-point voltage is set too low, the load capacity decreases at low speed). Refer to the V/F curve selection of Pr.01-43.	
The capacity of the drive is too small		Replace the drive with a larger capacity model.	
Overload during low-speed operation		Reduce the load during low-speed operation. Increase the drive capacity. Decrease the carrier frequency of Pr. 00-17.	
Torque compensation is too large		Adjust the torque compensation (refer to Pr. 07-26 Torque Compensation Gain) until the output current reduces and the motor does not stall.	
Check if the setting for stall prevention is correct.		Set the stall prevention to the proper value.	
Output phase loss		Check the status of three-phase motor. Check if the cable is broken or the screws are loose.	
Improper parameter settings for the speed tracking function (including restart after momentary power loss and restart after fault)		Correct the parameter settings for speed tracking. 1. Start the speed tracking function. 2. Adjust the maximum current for Pr.07-09 speed tracking.	

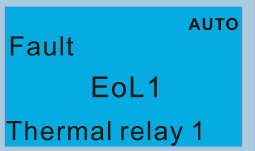
ID*	Display on LCM Keypad	Fault Name	Fault Descriptions
22		Electronics thermal relay 1 protection (EoL1)	Electronics thermal relay 1 protection. The drive coasts to stop once it activates.
<b>Action and Reset</b>			
Action level		Start counting when output current > 105% of motor 1 rated current	
Action time		Pr. 06-14 (if the output current is larger than 105% of motor 1 rated current again within 60 sec., the counting time reduces and is less than Pr. 06-14)	
Fault treatment parameter		N/A	
Reset method		Manual reset	
Reset condition		Reset in 5 sec. after the fault is cleared	
Record		Yes	
<b>Cause</b>		<b>Corrective Actions</b>	
The load is too large		Reduce the load.	
Accel./Decel. time or the working cycle is too short		Increase the setting values for Pr. 01-12–01-19 (Accel./Decel time)	
V/F voltage is too high		Adjust the settings for Pr.01-01–01-08 (V/F curve), especially the setting value for the mid-point voltage (if the mid-point voltage is set too low, the load capacity decreases at low speed). Refer to the V/F curve selection of Pr.01-43.	
Overload during low-speed operation. When using a general motor, even it operates below rated current, an overload may still occur during low-speed operation.		Decrease low-speed operation time. Replace the drive with a dedicated to VFD model. Increase the motor capacity.	
When using VFD dedicated motors, Pr. 06-13=0 (electronic thermal relay selection motor 1 = inverter motor)		Pr. 06-13=1 electronic thermal relay selection motor 1 = standard motor (motor with fan on the shaft).	
Incorrect value of electronic thermal relay		Reset to the correct motor rated current.	
The maximum motor frequency is set too low		Reset to the correct motor rated frequency.	
One drive to multiple motors		Set Pr. 06-13=2 electronic thermal relay selection motor 1= disable, and install thermal relay on each motor.	
Check if the setting for stall prevention is correct.		Set the stall prevention to the proper value.	
Torque compensation is too large		Adjust the torque compensation (refer to Pr.07-26 torque compensation gain) until the current reduces and the motor does no stall.	
Motor fan error		Check the status of the fan, or replace the fan.	
Unbalanced three-phase impedance of the motor		Replace the motor.	

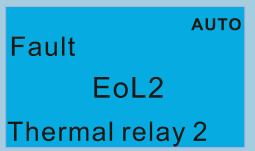
ID*	Display on LCM Keypad	Fault Name	Fault Descriptions
23		Electronic thermal relay 2 protection (EoL2)	Electronic thermal relay 2 protection. The drive coasts to stop once it activates.
<b>Action and Reset</b>			
Action level		Start counting when output current > 105% of motor 2 rated current	
Action time		Pr. 06-28 (If the output current is larger than 105% of motor 2 rated current again within 60 sec., the counting time reduces and is less than Pr. 06-28)	
Fault treatment parameter		N/A	
Reset method		Manual reset	
Reset condition		Reset in 5 sec. after the fault is cleared	
Record		Yes	
<b>Cause</b>		<b>Corrective Actions</b>	
The load is too large		Reduce the load	
Accel./Decel. time or the working cycle are too short		Increase the setting values for Pr.01-12-01-19 (accel./decel. time)	
V/F voltage is too high		Adjust the settings for Pr.01-01-01-08 (V/F curve), especially the setting value for the mid-point voltage (if the mid-point voltage is set too low, the load capacity decreases at low speed). Refer to the V/F curve selection setting of Pr.01-43.	
Overload during low-speed operation. When using general motor, even it operates below rated current, an overload may still occur during low-speed operation.		Decrease low-speed operation time. Replace the drive with a dedicated to VFD model. Increase the motor capacity.	
When using VFD dedicated motors, Pr. 06-27=0 (electronic thermal relay selection motor 2 = 0 inverter motor)		Pr. 06-27=1 Electronic thermal relay selection motor 2 = standard motor (motor with fan on the shaft).	
Incorrect value of electronic thermal relay		Reset to the correct motor rated current.	
The maximum motor frequency is set too low		Reset to the correct motor rated frequency.	
One drive to multiple motors		Set Pr. 06-27=2 Electronic thermal relay selection motor 2 = disable, and install thermal relay on each motor.	
Check if the setting for stall prevention is correct.		Set the stall prevention to the proper value.	
Torque compensation is too large		Adjust the torque compensation (refer to Pr.07-26 torque compensation gain) until the current reduces and the motor does no stall.	
Motor fan error		Check the status of the fan, or replace the fan.	
Unbalanced three-phase impedance of the motor		Replace the motor.	

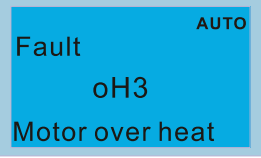
ID*	Display on LCM Keypad	Fault Name	Fault Descriptions
24_1		Motor overheating (oH3) PTC	Motor overheating (PTC) (Pr. 03-00 – Pr. 03-02=6 PTC), when PTC input > Pr. 06-30, the fault treatment acts according to Pr. 06-29.
<b>Action and Reset</b>			
Action level		PTC input value > Pr. 06-30 setting (Default = 50%)	
Action time		Immediately act	
Fault treatment parameter		Pr. 06-29 0: Warn and keep operation 1: Warn and ramp to stop 2: Warn and coast to stop 3: No warning	
Reset method		When Pr. 06-29=0, oH3 is a “Warning”. The “Warning” is automatically cleared. When Pr. 06-29=1 or 2, oH3 is a “Fault”. You must reset manually.	
Reset condition		Immediately reset	
Record		When Pr. 06-29=1 or 2, oH3 is a “Fault”, and the fault is recorded.	
Cause		<b>Corrective Actions</b>	
Motor shaft lock		Remove the shaft lock.	
The load is too large		Reduce the load. Increase the motor capacity.	
Ambient temperature is too high		Change the installed place if there are heating devices in the surroundings. Install/ add cooling fan or air conditioner to lower the ambient temperature.	
Motor cooling system error		Check the cooling system to make it work normally.	
Motor fan error		Replace the fan.	
Operate at low-speed too long.		Decrease low-speed operation time. Replace the motor with a dedicated to VFD model. Increase the motor capacity.	
Accel./Decel. time and working cycle are too short		Increase the setting values for Pr. 01-12–01-19 (accel./decel. time)	
V/F voltage is too high		Adjust settings for Pr.01-01–01-08 (V/F curve), especially the setting value for the mid-point voltage (if the mid-point voltage is set too low, the load capacity decreases at low speed).	
Check if the motor rated current matches that on the motor nameplate.		Reset to the correct motor rated current.	
Check if the PTC is properly set and wired.		Check the connection between PTC thermistor and the heat protection.	
Check if the setting for stall prevention is correct.		Set the stall prevention to the proper value.	
Unbalanced three-phase impedance of the motor		Replace the motor.	
Harmonics are too high.		Use remedies to reduce harmonics.	

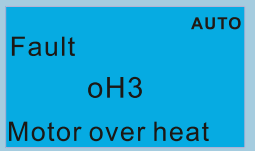
ID*	Display on LCM Keypad	Fault Name	Fault Descriptions
24_2		Motor overheating (oH3) PT100	Motor overheating (PT100) (Pr. 03-00 – Pr. 03-02=11 PT100). When PT100 input > Pr. 06-57 (default = 7V), the fault treatment acts according to Pr. 06-29.
<b>Action and Reset</b>			
Action level		PT100 input value > Pr. 06-57 setting (default = 7V)	
Action time		Immediately act	
Fault treatment parameter		Pr. 06-29 0: Warn and keep operation 1: Warn and ramp to stop 2: Warn and coast to stop 3: No warning	
Reset method		When Pr. 06-29=0 and the temperature < Pr. 06-56, oH3 is automatically cleared. When Pr. 06-29=1 or 2, oH3 is a “Fault”. You must reset manually.	
Reset condition		Immediately reset	
Record		When Pr. 06-29=1 or 2, oH3 is a “Fault”, and the fault is recorded.	
Cause		<b>Corrective Actions</b>	
Motor shaft lock		Remove the shaft lock.	
The load is too large		Reduce the load. Increase the motor capacity.	
Ambient temperature is too high		Change the installed place if there are heating devices in the surroundings. Install/ add cooling fan or air conditioner to lower the ambient temperature.	
Motor cooling system error		Check the cooling system to make it work normally.	
Motor fan error		Replace the fan.	
Operate at low-speed too long		Decrease low-speed operation time. Replace the motor with a dedicated to VFD model. Increase the motor capacity.	
Accel./Decel. time and working cycle are too short		Increase the setting values for Pr. 01-12–Pr.01-19 (accel./decel. time)	
V/F voltage is too high		Adjust settings for Pr.01-01–01-08 (V/F curve), especially the setting value for the mid-point voltage (if the mid-point voltage is set too low, the load capacity decreases at low speed).	
Check if the motor rated current matches that on the motor nameplate.		Reset to the correct motor rated current.	
Check if the PT100 is properly set and wired.		Check connection of PT100 thermistor.	
Check if the setting for stall prevention is correct.		Set the stall prevention to the proper value.	
Unbalanced three-phase impedance of the motor		Replace the motor.	
Harmonics are too high		Use remedies to reduce harmonics.	

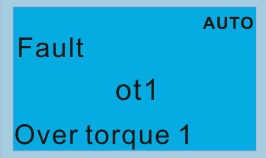
ID*	Display on LCM Keypad	Fault Name	Fault Descriptions
26		Over torque 1 (ot1)	When output current exceeds the over-torque detection level (Pr.06-07) and exceeds over-torque detection time (Pr.06-08), and when Pr.06-06 or Pr.06-09 is set to 2 or 4, the ot1 error displays.
<b>Action and Reset</b>			
Action level		Pr. 06-07	
Action time		Pr. 06-08	
Fault treatment parameter		Pr. 06-06 0: No function 1: Continue operation after Over-torque detection during constant speed operation 2: Stop after Over-torque detection during constant speed operation 3: Continue operation after Over-torque detection during RUN 4: Stop after Over-torque detection during RUN	
Reset method Reset condition		Auto	When Pr. 06-06=1 or 3, ot1 is a "Warning". The warning is automatically cleared when the output current < (Pr. 06-07 – 5%)
		Manual	When Pr. 06-06=2 or 4, ot1 is a "Fault". You must reset manually.
Record		Immediately reset	
Active level		When Pr. 06-06=2 or 4, ot1 is a "Fault", and the fault is recorded.	
Cause		<b>Corrective Actions</b>	
Incorrect parameter setting		Reset Pr. 06-07 and Pr. 06-08	
Mechanical failure (e.g. over-torque, mechanical lock)		Remove the causes of malfunction.	
The load is too large		Reduce the load. Replace the motor with a larger capacity model.	
Accel./Decel. time and working cycle are too short		Increase the setting values for Pr. 01-12–Pr. 01-19 (accel./decel. time)	
V/F voltage is too high		Adjust settings for Pr.01-01–01-08 (V/F curve), especially the setting value for the mid-point voltage (if the mid-point voltage is set too low, the load capacity decreases at low speed).	
The motor capacity is too small		Replace the motor with a larger capacity model.	
Overload during low-speed operation		Decrease low-speed operation time. Increase the motor capacity.	
Torque compensation is too large		Adjust the torque compensation (refer to Pr.07-26 torque compensation gain) until the current reduces and the motor does no stall.	
Improper parameter settings for speed tracking function (including restart after momentary power loss and restart after fault)		Correct the parameter settings for speed tracking. 1. Start the speed tracking function. 2. Adjust the maximum current for Pr.07-09 speed tracking.	

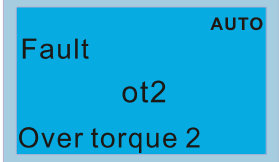

ID*	Display on LCM Keypad	Fault Name	Fault Descriptions
27		Over torque 2 (ot2)	When output current exceeds the over-torque detection level (Pr.06-10) and exceeds over-torque detection time (Pr.06-11), and when Pr.06-09 is set to 2 or 4, the ot2 error displays.
<b>Action and Reset</b>			
Action level		Pr. 06-10	
Action time		Pr. 06-11	
Fault treatment parameter		Pr. 06-09 0: No function 1: Continue operation after Over-torque detection during constant speed operation 2: Stop after Over-torque detection during constant speed operation 3: Continue operation after Over-torque detection during RUN 4: Stop after Over-torque detection during RUN	
Reset method Reset condition		Auto	When Pr. 06-09=1 or 3, ot2 is a "Warning". The warning is automatically cleared when the output current < (Pr. 06-10 – 5%).
		Manual	When Pr. 06-09=2 or 4, ot2 is a "Fault". You must reset manually.
Record		Immediately reset	
Active level		When Pr. 06-09=2 or 4, ot2 is a "Fault", and the fault is recorded.	
<b>Cause</b>		<b>Corrective Actions</b>	
Incorrect parameter setting		Reset Pr. 06-07 and Pr. 06-08	
Mechanical failure (e.g. over-torque, mechanical lock)		Remove the causes of malfunction.	
The load is too large.		Reduce the load. Replace the motor with a larger capacity model.	
Accel./Decel. time and working cycle are too short		Increase the setting values for Pr.01-12–01-19 (accel./decel. time).	
V/F voltage is too high		Adjust the settings for Pr.01-01–01-08 (V/F curve), especially the setting value for the mid-point voltage (if the mid-point voltage is set too low, the load capacity decreases at low speed).	
The motor capacity is too small		Replace the motor with a larger capacity model.	
Overload during low-speed operation		Decrease low-speed operation time. Increase the motor capacity.	
Torque compensation is too large		Adjust the torque compensation (refer to Pr.07-26 torque compensation gain) until the current reduces and the motor does no stall.	
Improper parameter settings for speed tracking function (including restart at momentary power loss and restart after fault)		Correct the parameter settings for speed tracking. 1. Start the speed tracking function. 2. Adjust the maximum current for Pr.07-09 speed tracking.	

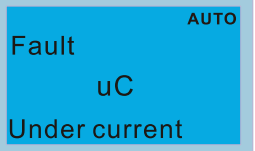
ID*	Display on LCM Keypad	Fault Name	Fault Descriptions
28		Under current (uC)	Low current detection
<b>Action and Reset</b>			
Action level	Pr. 06-71		
Action time	Pr. 06-72		
Fault treatment parameter	Pr. 06-73 0: No function 1: warn and coast to stop 2: warn and ramp to stop by 2 <sup>nd</sup> deceleration time 3: warn and operation continue		
Reset method	Auto	When Pr. 06-73=3, uC is a "Warning". The warning is automatically cleared when the output current > (Pr. 06-71+0.1A).	
Reset condition	Manual	When Pr. 06-73=1 or 2, uC is a "Fault". You must reset manually.	
Record	Immediately reset		
Active level	When Pr. 06-71=1 or 2, uC is a "Fault", and the fault is recorded.		
Cause	<b>Corrective Actions</b>		
Motor cable disconnection	Troubleshoot the connection between the motor and the load.		
Improper setting of low-current protection	Reset Pr. 06-71, Pr. 06-72 and Pr. 06-73 to proper settings.		
The load is too low	Check the load status. Check if the motor capacity matches the load.		

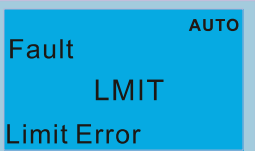
ID*	Display on LCM Keypad	Fault Name	Fault Descriptions
29		Limit Error (LMIT)	When Mlx=45 (forward run limit) or Mlx=44 (backward run limit) act during operation, LMIT error shows.
<b>Action and Reset</b>			
Action level	Mlx=44 (backward run limit) or Mlx=45(forward run limit)		
Action time	Immediately act		
Fault treatment parameter	N/A		
Reset method	Manual reset		
Reset condition	Immediately reset		
Record	Yes		
Cause	<b>Corrective Actions</b>		
The limit ON/OFF switch is on incorrect position	Install the limit ON/OFF switch to correct position.		
Deceleration time is too long, causing the motor cannot stop at limited position	Reduce deceleration time. Adjust setting values for brake level (Pr. 07-01 or the insert position on the brake unit).		
The motor cannot stop due to over-voltage stall prevention	Reset the over-voltage stall prevention.		
Malfunction caused by interference	Verify wiring of the control circuit and wiring/grounding of the main circuit to prevent interference.		

ID*	Display on LCM Keypad	Fault Name	Fault Descriptions
30	<div style="border: 1px solid black; padding: 5px; width: fit-content;"> <span style="float: right; font-size: small;">AUTO</span>                     Fault                      cF1                      EEPROM write err                 </div>	EEPROM write error (cF1)	Internal EEPROM cannot be programmed
<b>Action and Reset</b>			
Action level		Firmware internal detection	
Action time		cF1 acts immediately when the drive detects the fault	
Fault treatment parameter		N/A	
Reset method		Manual reset	
Reset condition		Immediately reset	
Record		Yes	
Cause		<b>Corrective Actions</b>	
Internal EEPROM cannot be programmed		Press "RESET" key or reset the parameter to the default setting, if cF1 still exists, return to the factory for repair. Cycle the power, if cF1 still exists, return to the factory for repair.	

ID*	Display on LCM Keypad	Fault Name	Fault Descriptions
31	<div style="border: 1px solid black; padding: 5px; width: fit-content;"> <span style="float: right; font-size: small;">AUTO</span>                     Fault                      cF2                      EEPROM read err                 </div>	EEPROM read error (cF2)	Internal EEPROM cannot be read
<b>Action and Reset</b>			
Action level		Firmware internal detection	
Action time		cF2 acts immediately when the drive detects the fault	
Fault treatment parameter		N/A	
Reset method		Manual reset	
Reset condition		Immediately reset	
Record		Yes	
Cause		<b>Corrective Actions</b>	
Internal EEPROM cannot be read		Press "RESET" key or reset the parameter to the default setting, if cF2 still exists, return to the factory for repair. Cycle the power, if cF2 error still exists, return to the factory for repair.	

ID*	Display on LCM Keypad	Fault Name	Fault Descriptions
33	<div style="border: 1px solid black; padding: 5px; width: fit-content;"> <span style="float: right; font-size: small;">AUTO</span>                     Fault                      cd1                      Ias sensor err                 </div>	U-phase error (cd1)	U-phase current detection error when power is ON
<b>Action and Reset</b>			
Action level		Hardware detection	
Action time		cd1 acts immediately when the drive detects the fault	
Fault treatment parameter		N/A	
Reset method		Power-off	
Reset condition		N/A	
Record		Yes	
Cause		<b>Corrective Actions</b>	
Hardware failure		Cycle the power. If cd1 still exists, return to the factory for repair.	

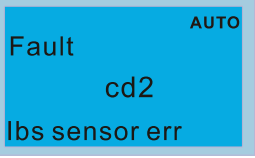
ID*	Display on LCM Keypad	Fault Name	Fault Descriptions
34		V-phase error (cd2)	V-phase current detection error when power ON
<b>Action and Reset</b>			
Action level		Hardware detection	
Action time		cd2 acts immediately when the drive detects the fault	
Fault treatment parameter		N/A	
Reset method		Power-off	
Reset condition		N/A	
Record		Yes	
Cause		<b>Corrective Actions</b>	
Hardware failure		Cycle the power. If cd2 still exists, return to the factory for repair.	

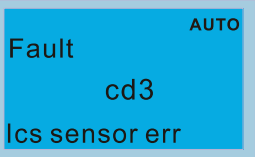
ID*	Display on LCM Keypad	Fault Name	Fault Descriptions
35		W-phase error (cd3)	W-phase current detection error when power ON
<b>Action and Reset</b>			
Action level		Hardware detection	
Action time		cd3 acts immediately when the drive detects the fault	
Fault treatment parameter		N/A	
Reset method		Power-off	
Reset condition		N/A	
Record		Yes	
Cause		<b>Corrective Actions</b>	
Hardware failure		Cycle the power. If cd3 still exists, return to the factory for repair.	

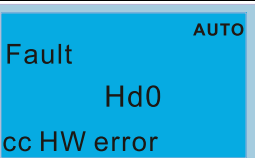
ID*	Display on LCM Keypad	Fault Name	Fault Descriptions
36		cc hardware failure (Hd0)	cc (current clamp) hardware protection error when power is ON
<b>Action and Reset</b>			
Action level		Hardware detection	
Action time		Hd0 acts immediately when the drive detects the fault	
Fault treatment parameter		N/A	
Reset method		Power-off	
Reset condition		N/A	
Record		Yes	
Cause		<b>Corrective Actions</b>	
Hardware failure		Cycle the power. If Hd0 still exists, return to the factory for repair.	

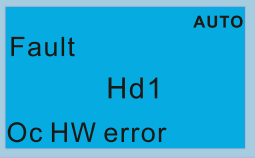
ID*	Display on LCM Keypad	Fault Name	Fault Descriptions
37		Oc hardware error (Hd1)	oc hardware protection error when power is ON
<b>Action and Reset</b>			
Action level		Hardware detection	
Action time		Hd1 acts immediately when the drive detects the fault	
Fault treatment parameter		N/A	
Reset method		Power-off	
Reset condition		N/A	
Record		Yes	
Cause		<b>Corrective Actions</b>	
Hardware failure		Cycle the power. If Hd1 still exists, return to the factory for repair.	

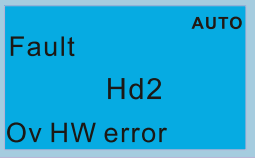
ID*	Display on LCM Keypad	Fault Name	Fault Descriptions
38		ov hardware error (Hd2)	ov hardware protection error when power is ON
<b>Action and Reset</b>			
Action level		Hardware detection	
Action time		Hd2 acts immediately when the drive detects the fault	
Fault treatment parameter		N/A	
Reset method		Power-off	
Reset condition		N/A	
Record		Yes	
Cause		<b>Corrective Actions</b>	
Hardware failure		Cycle the power. If Hd2 still exists, return to the factory for repair.	

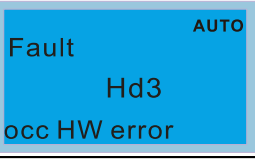
ID*	Display on LCM Keypad	Fault Name	Fault Descriptions
39		occ hardware error (Hd3)	Protection error of occ IGBT short-circuit detection when power is ON
<b>Action and Reset</b>			
Action level		Hardware detection	
Action time		Hd3 acts immediately when the drive detects the fault	
Fault treatment parameter		N/A	
Reset method		Power-off	
Reset condition		N/A	
Record		Yes	
Cause		<b>Corrective Actions</b>	
Hardware failure		Cycle the power. If Hd3 still exists, return to the factory for repair.	

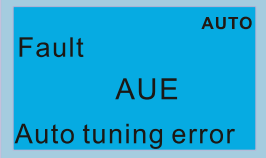
ID*	Display on LCM Keypad	Fault Name	Fault Descriptions
40		Auto-tuning error (AUE)	Motor auto-tuning error
<b>Action and Reset</b>			
Action level		Hardware detection	
Action time		Immediately act	
Fault treatment parameter		N/A	
Reset method		Manual reset	
Reset condition		Immediately reset	
Record		Yes	
Cause		<b>Corrective Actions</b>	
Press "STOP" key during auto-tuning		Re-execute auto-tuning.	
Incorrect motor capacity (too large or too small) and parameter setting		Check motor capacity and related parameters. Set the correct parameters, that is Pr. 01-01–Pr. 01-02. Set Pr.01-00 larger than motor rated frequency.	
Incorrect motor wiring		Check the wiring.	
Motor shaft lock		Remove the cause of motor shaft lock.	
The electromagnetic contactor is ON at output side (U/V/W) of the drive		Make sure the electromagnetic valve is OFF.	
The load is too large.		Reduce the load. Replace the motor with a larger capacity model.	
Accel./Decel. time is too short		Increase the setting values for Pr. 01-12–Pr. 01-19 (Accel./Decel. time).	

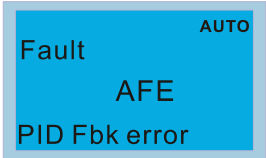
ID*	Display on LCM Keypad	Fault Name	Fault Descriptions
41		PID loss ACI (AFE)	PID feedback loss (analog feedback signal is only valid when the PID function is enabled)
<b>Action and Reset</b>			
Action level		When the analog input < 4mA (only detects 4–20mA analog input)	
Action time		Pr. 08-08	
Fault treatment parameter		Pr. 08-09 0: warn and keep operation 1: warn and ramp to stop 2: warn and coast to stop 3: warn and operate at last frequency	
Reset method		Auto	When Pr. 08-09=3 or 4, AFE is a "Warning". When the feedback signal is > 4mA, the "Warning" is automatically cleared.
		Manual	When Pr. 08-09=1 or 2, AFE is a "Fault". You must reset manually.
Reset condition		Immediately reset	
Record		When Pr. 08-09=1 or 2, AFE is a "Fault", and the fault is recorded; when Pr. 08-09=3 or 4, AFE is a "Warning", and the warning is not recorded.	
Cause		<b>Corrective Actions</b>	
PID feedback cable is loose or cut off		Tighten the terminal. Replace the cable with a new one.	
Feedback device failure		Replace the device with a new one.	
Hardware failure		Check all the wiring. If AFE fault still exists, return to the factory for repair.	

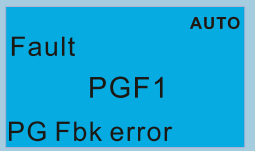
ID*	Display on LCM Keypad	Fault Name	Fault Descriptions
42		PG feedback error (PGF1)	The motor runs in a reverse direction to the frequency command direction.
<b>Action and Reset</b>			
Action level		Software detection	
Action time		Pr. 10-09	
Fault treatment parameter		Pr. 10-08 0: warn and keep operation 1: warn and ramp to stop 2: warn and coast to stop	
Reset method		Manual reset	
Reset condition		Immediately reset	
Record		Yes	
Cause		<b>Corrective Actions</b>	
Incorrect parameter setting of encoder		Reset encoder parameter (Pr. 10-02).	
Check wiring of the encoder		Re-wire the encoder.	
PG card or PG encoder failure		Replace PG card or encoder with a new one.	
Malfunction caused by interference		Verify wiring of the control circuit and wiring/grounding of the main circuit to prevent interference.	

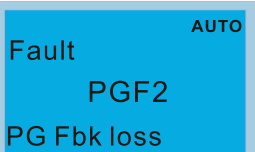
ID*	Display on LCM Keypad	Fault Name	Fault Descriptions
43		PG feedback loss (PGF2)	Pr. 10-00 and Pr. 10-02 is not set in the PG control mode. When press "RUN" key, PGF2 fault occurs.
<b>Action and Reset</b>			
Action level		Software detection	
Action time		Immediately act	
Fault treatment parameter		N/A	
Reset method		Manual reset	
Reset condition		Immediately reset	
Record		Yes	
Cause		<b>Corrective Actions</b>	
Incorrect setting of encoder parameter		Reset encoder parameters (Pr. 10-00 and Pr. 10-02)	
Incorrect selection of the control mode		Choose the correct control mode.	

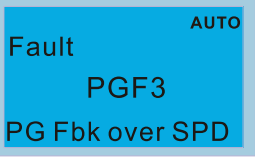
ID*	Display on LCM Keypad	Fault Name	Fault Descriptions
44		PG feedback stall (GF3)	Under PG mode, when the motor frequency exceeds the encoder observer stall level (Pr. 10-10) and starts to count, the fault time is longer than the detection time of encoder observer stall (Pr. 10-11), then PGF3 fault occurs.
<b>Action and Reset</b>			
Action level		Pr. 10-10	
Action time		Pr. 10-11	
Fault treatment parameter		Pr. 10-12 0: warn and keep operation 1: warn and ramp to stop 2: warn and coast to stop	
Reset method		Manual reset	
Reset condition		Immediately reset	
Record		Yes	
Cause		<b>Corrective Actions</b>	
Incorrect setting of encoder parameter		Reset encoder parameter (Pr. 10-01)	
Pr. 01-00 is set too small		Set proper value for Pr. 01-00.	
Incorrect setting for ASR parameters and accel./decel. time		Reset ASR parameters. Set correct accel./decel. time.	
Incorrect setting for PG feedback stall		Reset proper values for Pr. 10-10 and Pr. 10-11	

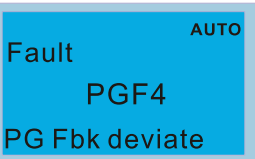
ID*	Display on LCM Keypad	Fault Name	Fault Descriptions
45		PG slip error (PGF4)	Under PG mode, when the motor frequency exceeds encoder observer slip range (Pr. 10-13) and starts to count, the fault time is longer than the detection time of encoder observer slip (Pr. 10-14), PGF4 fault occurs.
<b>Action and Reset</b>			
Action level		Pr. 10-13	
Action time		Pr. 10-14	
Fault treatment parameter		Pr. 10-15 0: warn and keep operation 1: warn and ramp to stop 2: warn and coast to stop	
Reset method		Auto	When Pr. 10-15=0, PGF4 is a "Warning", when the deviation between output frequency and motor frequency is smaller than the encoder observer slip range, the warning is automatically cleared.
		Manual	When Pr. 10-15=1 or 2, PGF4 is a "Fault". You must reset manually.
Reset condition		Immediately reset	
Record		When Pr. 10-15=1 or 2, PGF4 is a "Fault", and the fault is recorded.	
Cause		<b>Corrective Actions</b>	
Incorrect settings for PG feedback parameters		Reset correct values for Pr. 10-13 and Pr. 10-14.	
Incorrect settings for ASR parameters and accel./decel. time		Reset ASR parameters. Set correct accel./decel. time.	
Incorrect settings of encoder parameters		Reset encoder parameters (Pr. 10-01).	
Accel./Decel. time is too short		Reset proper accel./decel. time.	
Incorrect settings of torque limit parameters (Pr. 06-12, Pr. 11-17-20)		Reset proper setting values for Pr. 06-12 and Pr. 11-17-Pr. 17-20.	
Motor shaft lock		Remove causes of motor shaft lock.	
Mechanical brake is not released		Check the action sequence of the system.	

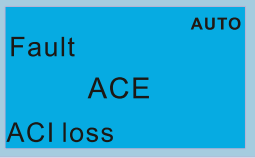

ID*	Display on LCM Keypad	Fault Name	Fault Descriptions
48		ACI loss (ACE)	Analog input loss (including all the 4–20mA analog signal)
<b>Action and Reset</b>			
Action level	When the analog input is < 4mA (only detects 4–20mA analog input)		
Action time	Immediately act		
Fault treatment parameter	Pr. 03-19 0: Disable 1: Continue operation at the last frequency (warning, ANL is displayed on the keypad) 2: Decelerate to stop (warning, ANL is displayed on the keypad) 3: Stop immediately and display ACE		
Reset method	Auto	When Pr. 03-19=1 or 2, ACE is a “Warning”. When analog input signal is > 4mA, the warning is automatically cleared.	
	Manual	When Pr. 03-19=3, ACE is a “Fault”. You must reset manually.	
Reset condition	Immediately reset		
Record	When Pr. 03-19=3, ACE is a “Fault”, and the fault is recorded.		
Cause	<b>Corrective Actions</b>		
ACI cable is loose or cut off	Tighten the terminal. Replace the cable with a new one.		
External device failure	Replace the device with a new one.		
Hardware failure	Check all the wiring. If ACE still exists, return to the factory for repair.		

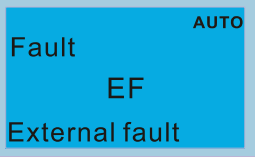
ID*	Display on LCM Keypad	Fault Name	Fault Descriptions
49		External fault (EF)	External fault. When the drive decelerates based on the setting of Pr. 07-20, the EF fault displays on the keypad.
<b>Action and Reset</b>			
Action level	MIx=EF and the MI terminal is ON		
Action time	Immediately act		
Fault treatment parameter	Pr. 07-20 0: Coast to stop 1: Stop by 1 <sup>st</sup> deceleration time 2: Stop by 2 <sup>nd</sup> deceleration time 3: Stop by 3 <sup>rd</sup> deceleration time 4: Stop by 4 <sup>th</sup> deceleration time 5: System deceleration 6: Automatic deceleration (Pr. 01-46)		
Reset method	Manual reset		
Reset condition	Manual reset only after the external fault is cleared (terminal status is recovered)		
Record	Yes		
Cause	<b>Corrective Actions</b>		
External fault	Press RESET key after the fault is cleared.		

ID*	Display on LCM Keypad	Fault Name	Fault Descriptions
50		Emergency stop (EF1)	When the contact of Mlx=EF1 is ON, the output stops immediately and displays EF1 on the keypad. The motor is in free running.
<b>Action and Reset</b>			
Action level		Mlx=EF1 and the MI terminal is ON	
Action time		Immediately act	
Fault treatment parameter		N/A	
Reset method		Manual reset	
Reset condition		Manual reset only after the external fault is cleared (terminal status is recovered)	
Record		Yes	
Cause		<b>Corrective Actions</b>	
When Mlx=EF1 activates		Verify if the system is back to normal condition, and then press "RESET" key to go back to the default.	

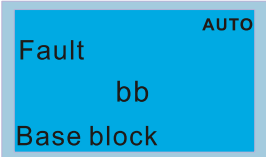
ID*	Display on LCM Keypad	Fault Name	Fault Descriptions
51		External base block (bb)	When the contact of Mlx=bb is ON, the output stops immediately and displays bb on the keypad. The motor is in free running.
<b>Action and Reset</b>			
Action level		Mlx=bb and the MI terminal is ON	
Action time		Immediately act	
Fault treatment parameter		N/A	
Reset method		The display "bb" is automatically cleared after the fault is cleared.	
Reset condition		N/A	
Record		No	
Cause		<b>Corrective Actions</b>	
When Mlx=bb activates		Verify if the system is back to normal condition, and then press "RESET" key to go back to the default.	

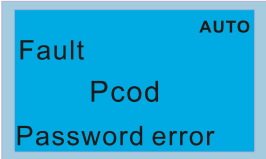
ID*	Display on LCM Keypad	Fault Name	Fault Descriptions
52		Password is locked (Pcod)	Entering the wrong password three consecutive times
<b>Action and Reset</b>			
Action level		Entering the wrong password three consecutive times	
Action time		Immediately act	
Fault treatment parameter		N/A	
Reset method		Manual reset	
Reset condition		Power-off	
Record		Yes	
Cause		<b>Corrective Actions</b>	
Incorrect password input through Pr. 00-07		<ol style="list-style-type: none"> <li>Input the correct password after rebooting the motor drive.</li> <li>If you forget the password, do the following steps: Step 1: Input 9999 and press ENTER. Step 2: Repeat step 1. Input 9999 and press ENTER. (You need to finish step 1 and step 2 within 10 seconds. If you don't finish the two steps in 10 seconds, try again.)</li> <li>The parameter settings return to the default when the "Input 9999" process is finished.</li> </ol>	

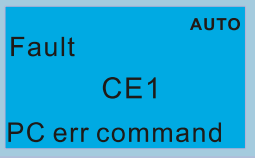
ID*	Display on LCM Keypad	Fault Name	Fault Descriptions
54		Illegal command (CE1)	Communication command is illegal
<b>Action and Reset</b>			
Action level		When the function code is not 03, 06, 10, or 63.	
Action time		Immediately act	
Fault treatment parameter		N/A	
Reset method		Manual reset	
Reset condition		Immediately reset	
Record		No	
<b>Cause</b>		<b>Corrective Actions</b>	
Incorrect communication command from the upper unit		Check if the communication command is correct.	
Malfunction caused by interference		Verify the wiring and grounding of the communication circuit. It is recommended to separate the communication circuit from the main circuit, or wire in 90 degree for effective anti-interference performance.	
Different communication setting from the upper unit		Check if the setting for Pr.09-02 is the same as the setting for the upper unit.	
Disconnection or bad connection of the cable		Check the cable and replace it if necessary.	

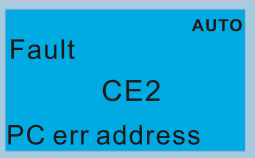
ID*	Display on LCM Keypad	Fault Name	Fault Descriptions
55		Illegal data address (CE2)	Data address is illegal
<b>Action and Reset</b>			
Action level		When the data address is correct.	
Action time		Immediately act	
Fault treatment parameter		N/A	
Reset method		Manual reset	
Reset condition		Immediately reset	
Record		No	
<b>Cause</b>		<b>Corrective Actions</b>	
Incorrect communication command from the upper unit		Check if the communication command is correct.	
Malfunction caused by interference		Verify the wiring and grounding of the communication circuit. It is recommended to separate the communication circuit from the main circuit, or wire in 90 degree for effective anti-interference performance.	
Different communication setting from the upper unit		Check if the setting for Pr.09-02 is the same as the setting for the upper unit.	
Disconnection or bad connection of the cable		Check the cable and replace it if necessary.	

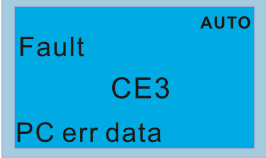
ID*	Display on LCM Keypad	Fault Name	Fault Descriptions
56		Illegal data value (CE3)	Data value is illegal
<b>Action and Reset</b>			
Action level		When the data length is too long	
Action time		Immediately act	
Fault treatment parameter		N/A	
Reset method		Manual reset	
Reset condition		Immediately reset	
Record		No	
<b>Cause</b>		<b>Corrective Actions</b>	
Incorrect communication command from the upper unit		Check if the communication command is correct.	
Malfunction caused by interference		Verify the wiring and grounding of the communication circuit. It is recommended to separate the communication circuit from the main circuit, or wire in 90 degree for effective anti-interference performance.	
Different communication setting from the upper unit		Check if the setting for Pr.09-02 is the same as the setting for the upper unit.	
Disconnection or bad connection of the cable		Check the cable and replace it if necessary.	

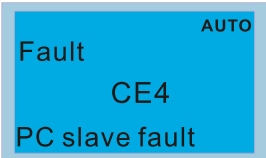
ID*	Display on LCM Keypad	Fault Name	Fault Descriptions
57		Data is written to read-only address (CE4)	Data is written to read-only address
<b>Action and Reset</b>			
Action level		When the data is written to read-only address.	
Action time		Immediately act	
Fault treatment parameter		N/A	
Reset method		Manual reset	
Reset condition		Immediately reset	
Record		No	
<b>Cause</b>		<b>Corrective Actions</b>	
Incorrect communication command from the upper unit		Check if the communication command is correct.	
Malfunction caused by interference		Verify the wiring and grounding of the communication circuit. It is recommended to separate the communication circuit from the main circuit, or wire in 90 degree for effective anti-interference performance.	
Different communication setting from the upper unit		Check if the setting for Pr.09-02 is the same as the setting for the upper unit.	
Disconnection or bad connection of the cable		Check the cable and replace it if necessary.	

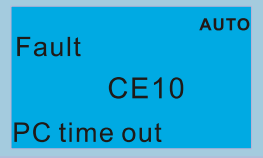
ID*	Display on LCM Keypad	Fault Name	Fault Descriptions
58		MODBUS transmission time-out (CE10)	MODBUS transmission time-out occurs
<b>Action and Reset</b>			
Action level	When the communication time exceeds the detection time for Pr.09-03 time-out.		
Action time	Pr. 09-03		
Fault treatment parameter	Pr. 09-02 0: Warn and continue operation 1: Warn and ramp to stop 2: Warn and coast to stop 3: No warning and continue operation		
Reset method	Manual reset		
Reset condition	Immediately reset		
Record	Yes		
Cause	<b>Corrective Actions</b>		
The upper unit does not transmit the communication command within Pr.09-03 setting time.	Check if the upper unit transmits the communication command within the setting time for Pr.09-03.		
Malfunction caused by interference	Verify the wiring and grounding of the communication circuit. It is recommended to separate the communication circuit from the main circuit, or wire in 90 degree for effective anti-interference performance.		
Different communication setting from the upper unit	Check if the setting for Pr.09-02 is the same as the setting for the upper unit.		
Disconnection or bad connection of the cable	Check the cable and replace it if necessary.		

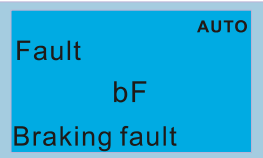
ID*	Display on LCM Keypad	Fault Name	Fault Descriptions
60		Brake transistor error (bF)	The brake transistor of the motor drive is abnormal. (for the models with built-in brake transistor)
<b>Action and Reset</b>			
Action level	Hardware detection		
Action time	Immediately act		
Fault treatment parameter	N/A		
Reset method	Manual reset		
Reset condition	Immediately reset		
Record	Yes		
Cause	<b>Corrective Actions</b>		
Hardware error	<ol style="list-style-type: none"> <li>Press "RESET" key to go back to the default. If bF still exists, return to the factory for repair.</li> <li>Power off the motor drive since the internal circuit is abnormal. Use a meter to check if it is short-circuit between B2 to DC-. If short-circuit exists, return to the factory for repair.</li> </ol>		
Malfunction caused by interference	Verify wiring/grounding of the main circuit to prevent interference.		
Using the incorrect brake resistor	Check if the resistance value of the brake resistor matches to the drive.		
Incorrect wiring of the brake resistor	Refer to the optional accessories instruction in chapter 7, and verify the wiring.		

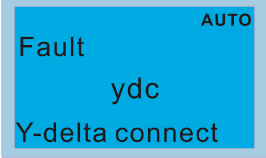
ID*	Display on LCM Keypad	Fault Name	Fault Descriptions
61		Y-connection / $\Delta$ -connection switch error (ydc)	An error occurs when Y- $\Delta$ switches
<b>Action and Reset</b>			
Action level	1. ydc occurs when the confirmation signals of Y-connection and $\Delta$ -connection are conducted at the same time. 2. If any of confirmation signals is not conducted within Pr. 05-25, ydc occurs.		
Action time	Pr. 05-25		
Fault treatment parameter	N/A		
Reset method	Manual reset		
Reset condition	Can be reset only when the confirmation signal of Y-connection is conducted if it is Y-connection, or when the confirmation signal of $\Delta$ -connection is conducted if it is $\Delta$ -connection.		
Record	Yes		
<b>Cause</b>		<b>Corrective Actions</b>	
The electromagnetic valve operates incorrectly during Y- $\Delta$ switch.		Check if the electromagnetic valve works normally. If not, replace it.	
Incorrect parameter setting		Check if related parameters are all set up and set correctly.	
The wiring of Y- $\Delta$ switch function is incorrect		Check the wiring.	

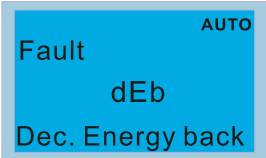
ID*	Display on LCM Keypad	Fault Name	Fault Descriptions
62		Deceleration energy backup error (dEb)	When Pr. 07-13 is not 0, and the power is suddenly off, causing the DCBUS voltage lower than the dEb action level, the dEb function acts and the motor ramps to stop. Then dEb displays on the keypad.
<b>Action and Reset</b>			
Action level	When Pr. 07-13 is not 0, and the DCBUS voltage is lower than the level of dEb.		
Action time	Immediately act		
Fault treatment parameter	N/A		
Reset method	Auto	When Pr. 07-13=2 (dEb with auto-acceleration / auto-deceleration, the drive outputs the frequency after the power is restored): dEb is automatically cleared.	
	Hand	When Pr. 07-13=1 (dEb with auto-acceleration / auto-deceleration, the drive does not output the frequency after the power is restored): The drive stops when dEb acts and the rotation speed becomes 0 Hz, then the drive can be reset manually.	
Reset condition	Auto: The fault is automatically cleared. Hand: When the drive decelerates to 0 Hz.		
Record	Yes		
<b>Cause</b>		<b>Corrective Actions</b>	
Unstable power source or the power is off		Check the power system.	
There is any other large load operates in the power system		1. Replace power system with a larger capacity. 2. Use a different power system from the large load system.	

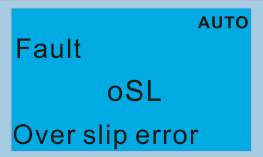
ID*	Display on LCM Keypad	Fault Name	Fault Descriptions
63		Over slip error (oSL)	On the basis of the maximum slip limit set via Pr. 10-29, the speed deviation is abnormal. When the motor drive outputs at constant speed, F>H or F<H exceeds the level set via Pr. 07-29, and it exceeds the time set via Pr. 07-30, oSL shows. oSL occurs in induction motors only.
<b>Action and Reset</b>			
Action level	Pr. 07-29 100% of Pr. 07-29 = the maximum limit of the slip frequency (Pr. 10-29)		
Action time	Pr. 07-30		
Fault treatment parameter	Pr. 07-31 0: Warn and continue operation 1: Warn and ramp to stop 2: Warn and coast to stop 3: No warning		
Reset method	Auto	Pr. 07-31=0 is a warning. When the motor drive outputs at constant speed, and F>H or F<H does not exceed the level set via Pr. 07-29 anymore, oSL warning will be cleared automatically.	
	Hand	When Pr. 07-31=1 or 2, oSL is an error, and it needs to reset manually.	
Reset condition	Immediately reset		
Record	Pr. 07-31=1 or 2, oSL is "Fault", and will be recorded.		
Cause	<b>Corrective Actions</b>		
Any of the motor parameters in parameter group 5 may be incorrect	Check the motor parameters		
Overload	Decrease the load		
Any of the setting value of Pr. 07-29, 07-30, and 10-29 is improper	Check the setting of oSL protection function related parameters		

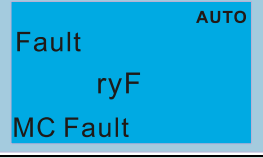
ID*	Display on LCM Keypad	Fault Name	Fault Descriptions
64		Electric valve switch error (ryF)	Electric valve switch error when executing Soft Start
<b>Action and Reset</b>			
Action level	Hardware detection (Frame D and above)		
Action time	Immediately act		
Fault treatment parameter	N/A		
Reset method	Manual reset		
Reset condition	Reset when the electric valve switch is correctly closed		
Record	Yes		
Cause	<b>Corrective Actions</b>		
The input power is abnormal	Check if the power is shut down during the drive operation? Check if the three-phase input power is normal.		
Malfunction caused by interference	Verify the wiring/grounding of the main circuit to prevent interference.		
Hardware failure	Cycle the power after checking the power. If ryF error still exists, return to the factory for repair.		

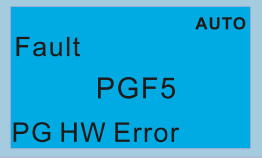
ID*	Display on LCM Keypad	Fault Name	Fault Descriptions
65		Hardware error of PG card (PGF5)	Hardware error of PG card
<b>Action and Reset</b>			
Action level	1. The PG card (PG01U/PG02U) can only be used with the permanent magnetic motor. When the power is ON and Pr. 00-04=29 pole section shows 0 or 7 (wiring error or no U/V/W signal input), the PGF5 error will be activated. 2. The drive receives the operation command right after the power is ON, meanwhile, the PG card is not ready yet.		
Action time	Immediately act		
Fault treatment parameter	N/A		
Reset method	Manual reset		
Reset condition	Reset after cycle the power.		
Record	Yes		
Cause	<b>Corrective Actions</b>		
Wiring error or there is no U/V/W signal input	Re-connect the cables correctly		
Encoder failure	Verify if it is the UVW encoder		
The setting of encoder parameter is incorrect	Choose the correct setting of Pr. 10-00		
If the motor selection switch of PG card on the correct position	Check if it is the UVW encoder or Delta encoder		
PG card selection is incorrect	Install the correct PG card		

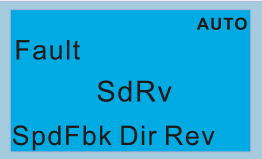
ID*	Display on LCM Keypad	Fault Name	Fault Descriptions
68		Reverse direction of the speed feedback (SdRv)	Rotating direction is different from the commanding direction detected by the sensorless
<b>Action and Reset</b>			
Action level	Software detection		
Action time	Pr. 10-09		
Fault treatment parameter	Pr. 10-08 0: Warn and keep operation 1: Warn and ramp to stop 2: Warn and coast to stop		
Reset method	Manual reset		
Reset condition	Immediately reset		
Record	When Pr. 10-08=1 or 2, SdRv is a "Fault", and the fault is recorded.		
Cause	<b>Corrective Actions</b>		
The setting of Pr.10-25 FOC bandwidth of speed observer is improper	Decrease the setting of Pr. 10-25		
The setting of motor parameter is incorrect	Reset the motor parameter and execute parameter tuning		
The motor cable is abnormal or broken	Check if the cable is well functioned or replace the cable		
A reverse force is exerted, or the motor runs in a reverse direction at start	Start speed tracking function (Pr. 07-12)		
Malfunction caused by interference	Verify the wiring of the control circuit and wiring/grounding of the main circuit to prevent interference.		

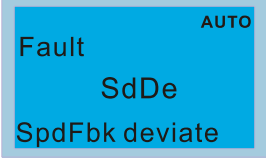

ID*	Display on LCM Keypad	Fault Name	Fault Descriptions
69		Over speed rotation feedback (SdOr)	Over speed rotation detected by sensorless
<b>Action and Reset</b>			
Action level		Pr. 10-10	
Action time		Pr. 10-11	
Fault treatment parameter		Pr. 10-12 0: Warn and keep operation 1: Warn and ramp to stop 2: Warn and coast to stop	
Reset method		Manual reset	
Reset condition		Immediately reset	
Record		When Pr. 10-12=1 or 2, SdOr is a "Fault", and the fault is recorded.	
<b>Cause</b>		<b>Corrective Actions</b>	
The setting of Pr. 10-25 FOC bandwidth of speed observer is improper		Decrease the setting of Pr. 10-25	
The setting of ASR bandwidth of speed controller is improper		Increase the bandwidth of ASR speed controller	
The setting of motor parameter is incorrect		Reset motor parameter and execute parameter tuning	
Malfunction caused by interference		Verify the wiring of the control circuit and wiring/grounding of the main circuit to prevent interference.	

ID*	Display on LCM Keypad	Fault Name	Fault Descriptions
70		Large deviation of speed feedback (SdDe)	A large deviation between the rotating speed and the command detected by the sensorless
<b>Action and Reset</b>			
Action level	Pr. 10-13		
Action time	Pr. 10-14		
Fault treatment parameter	Pr. 10-15 0: Warn and keep operation 1: Warn and ramp to stop 2: Warn and coast to stop		
Reset method	Manual reset		
Reset condition	Immediately reset		
Record	When Pr. 10-15=1 or 2, SdDe is a "Fault", and the fault is recorded.		
Cause	<b>Corrective Actions</b>		
Improper parameter setting for abnormal rotating slip function	Reset proper setting for Pr. 10-13 and Pr. 10-14		
Improper parameter setting for ASR and acceleration/deceleration	Reset ASR parameters Set proper acceleration/deceleration time		
The acceleration/deceleration time is too short	Reset proper acceleration/deceleration time		
Motor shaft lock	Remove the cause of motor shaft lock		
The mechanical brake is not released	Verify the system action timeline		
Incorrect parameter setting for torque limit (Pr. 06-12, Pr. 11-17 – 20)	Adjust the setting to proper value		
Malfunction caused by interference	Verify the wiring of the control circuit and wiring/grounding of the main circuit to prevent interference.		

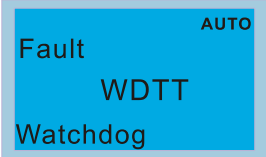
ID*	Display on LCM Keypad	Fault Name	Fault Descriptions
71		Watchdog ( WDTT )	Watchdog error
<b>Action and Reset</b>			
Action level	Hardware detection		
Action time	N/A		
Fault treatment parameter	N/A		
Reset method	Hardware failure, and cannot reset. Cycle the power.		
Reset condition	N/A		
Record	Yes		
Cause	<b>Corrective Actions</b>		
Hardware interference	Verify the wiring of the control circuit and wiring/grounding of the main circuit to prevent interference. If the WDTT fault still exists, return to the factory for repair.		

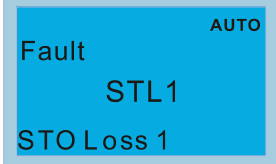
ID*	Display on LCM Keypad	Fault Name	Fault Descriptions
72		STO Loss 1 (STL1)	STO1 – SCM1 internal loop detection error
<b>Action and Reset</b>			
Action level		Hardware detection	
Action time		Immediately act	
Fault treatment parameter		N/A	
Reset method		Hardware failure, and cannot reset. Cycle the power.	
Reset condition		N/A	
Record		Yes	
Cause		<b>Corrective Actions</b>	
STO1 and SCM1 short circuit lines are not connected		Connect the short circuit line	
Hardware failure		After you make sure all the wiring is correct, if STOL fault still exists after cycling the power, please return to the factory for repair.	
Bad connection of the IO card		Check if the PIN of IO card is broken? Check if the IO card connects to the control board correctly, and if the screws are tightened well?	
The IO card does not match the version of the control board		Contact local agent or Delta	

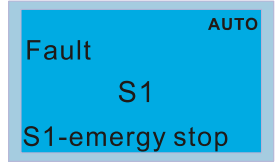
ID*	Display on LCM Keypad	Fault Name	Fault Descriptions
73		Emergency stop for external safety (S1)	Emergency stop for external safety
<b>Action and Reset</b>			
Action level		Hardware detection	
Action time		Immediately act	
Fault treatment parameter		N/A	
Reset method		Manual reset	
Reset condition		Reset only after S1 error is cleared.	
Record		Yes	
Cause		<b>Corrective Actions</b>	
The switch action of S1 and SCM (OPEN)		Reset the switch and cycle the power.	
S1 and SCM short circuit lines are not connected		Re-connect the short circuit lines	
Malfunction caused by interference		Verify the wiring/grounding of the main circuit, control circuit and encoder to prevent interference.	
Hardware failure		If S1 fault still exists after cycling the power, please return to the factory for repair.	
Poor connection of the IO card		Check if the PIN of IO card is broken? Check if the IO card connects to the control board correctly, and if the screws are tightened well?	
The IO card does not match the version of the control board		Contact local agent or Delta	

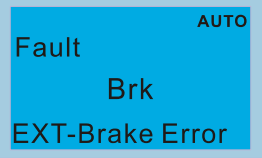
ID*	Display on LCM Keypad	Fault Name	Fault Descriptions
75		External brake error (Brk)	External mechanical brake error The MO terminal is active when MOx=12, 42, 47 or 63, but the MIx=55 does not receive signal for mechanical brake action during the set time of Pr. 02-56.
<b>Action and Reset</b>			
Action level		MIx=55 did not receive signal for the mechanical brake action during the set time of Pr. 02-56.	
Action time		Pr. 02-56	
Fault treatment parameter		N/A	
Reset method		Manual reset	
Reset condition		Immediately reset	
Record		Yes	
Cause		<b>Corrective Actions</b>	
Mechanical brake error		Verify if the mechanical brake can work correctly. Replace mechanical brake.	
Incorrect parameter setting		If there is no brake-confirming signal to use, set Pr. 02-56=0.	
Signal cable is loose or cut off		Tighten the screws. Replace the signal cable with a new one.	
The time of Pr. 02-56 is set too short		Increase the time setting of Pr. 02-56	
Malfunction caused by interference		Verify the wiring/grounding of the main circuit, control circuit and encoder to prevent interference.	

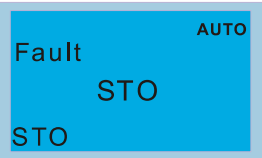
ID*	Display on LCM Keypad	Fault Name	Fault Descriptions
76		STO ( STO )	Safety Torque Off function active
<b>Action and Reset</b>			
Action level		Hardware detection	
Action time		Immediately act	
Fault treatment parameter		N/A	
Reset method		Auto	When Pr. 06-44=1 and after STO error is cleared, it automatically resets.
		Manual	When Pr. 06-44=0 and after STO error is cleared, reset it manually.
Reset condition		Reset only after STO error is cleared.	
Record		Yes	
Cause		<b>Corrective Actions</b>	
The switch action of STO1/SCM1 and STO2/SCM2 (OPEN)		Reset the switch (ON) and cycle the power	
Poor connection of the IO card		Check if the PIN of IO card is broken? Check if the IO card connects to the control board correctly, and if the screws are tightened well?	
The IO card does not match the version of the control board		Contact local agent or Delta	

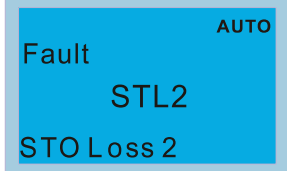
ID*	Display on LCM Keypad	Fault Name	Fault Descriptions
77		STO Loss 2 (STL2)	STO2–SCM2 internal loop detection error
<b>Action and Reset</b>			
Action level		Hardware detection	
Action time		Immediately act	
Fault treatment parameter		N/A	
Reset method		Hardware failure, and cannot reset. Cycle the power.	
Reset condition		N/A	
Record		Yes	
Cause		<b>Corrective Actions</b>	
STO2 and SCM2 short circuit lines are not connected		Connect the short circuit lines	
Hardware failure		After you make sure all the wiring is correct, if STL2 fault still exists after cycling the power, please return to the factory for repair.	
Poor connection of the IO card		Check if the PIN of IO card is broken? Check if the IO card connects to the control board correctly, and if the screws are tightened well?	
The IO card does not match the version of the control board		Contact local agent or Delta	

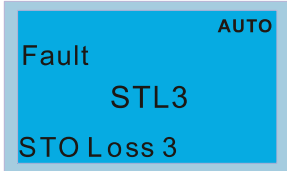
ID*	Display on LCM Keypad	Fault Name	Fault Descriptions
78		STO Loss 3 (STL3)	STO1–SCM1 and STO2–SCM2 internal loop detection error
<b>Action and Reset</b>			
Action level		Hardware detection	
Action time		Immediately act	
Fault treatment parameter		N/A	
Reset method		Hardware failure, and cannot reset. Cycle the power.	
Reset condition		N/A	
Record		Yes	
Cause		<b>Corrective Actions</b>	
STO1 and SCM1, or STO2 and SCM2 short circuit lines are not connected		Re-connect the short circuit lines	
Hardware failure		After you make sure all the wiring is correct, if STL3 fault still exists after cycling the power, please return to the factory for repair.	
Poor connection of the IO card		Check if the PIN of IO card is broken? Check if the IO card connects to the control board correctly, and if the screws are tightened well?	
The IO card does not match the version of the control board		Contact local agent or Delta	

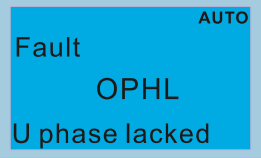
ID*	Display on LCM Keypad	Fault Name	Fault Descriptions
82		Output phase loss U phase (OPHL)	U phase output phase loss
<b>Action and Reset</b>			
Action level	Pr. 06-47		
Action time	Pr. 06-46 Pr. 06-48: Use the setting value of Pr. 06-48 first if there is DC braking function, and then use that of Pr. 06-46.		
Fault treatment parameter	Pr.06-45 0: Warn and keep operation 1: Warn and ramp to stop 2: Warn and coast to stop 3: No warning		
Reset method	Manual reset		
Reset condition	Immediately reset		
Record	Pr. 06-45=1 or 2 is "Fault", and will be recorded.		
Cause	<b>Corrective Actions</b>		
The three-phase impedance of motor is unbalanced	Replace the motor.		
The motor is wired incorrectly	Check the cable condition. Replace the cable.		
Using a single-phase motor	Choose a three-phase motor		
The current sensor is damaged	Check the flat cable of the control board. Re-do the wiring and test again if the flat cable is loose. If the fault still exists, return the unit to the factory. Verify that the three-phase current is balanced via a current clamp meter. If it is balanced and the OPHL fault still exists, return the unit to the factory		
The drive capacity is much larger than the motor capacity	Make sure the capacity of the drive and motor match to each other.		

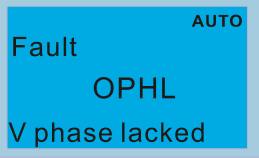
ID*	Display on LCM Keypad	Fault Name	Fault Descriptions
83		Output phase loss V phase (OPHL)	V phase output phase loss
<b>Action and Reset</b>			
Action level	Pr. 06-47		
Action time	Pr. 06-46 Pr. 06-48: Use the setting value of Pr. 06-48 first. If DC braking function activates, use that of Pr. 06-46.		
Fault treatment parameter	Pr. 06-45 0: Warn and keep operation 1: Warn and ramp to stop 2: Warn and coast to stop 3: No warning		
Reset method	Manual reset		
Reset condition	Immediately reset		
Record	When Pr. 06-45=1 or 2, OPHL is a "Fault", and the fault is recorded.		
Cause	<b>Corrective Actions</b>		
Unbalanced three-phase impedance of the motor	Replace the motor.		
Check if the wiring is incorrect	Check the cable and replace it if necessary.		
Check if the motor is a single-phase motor	Choose a three-phase motor.		
Check if the current sensor is broken	Check if the control board cable is loose. If yes, reconnect the cable and run the drive to test. If the fault still exists, return to the factory for repair. Check if the three-phase current is balanced with a current clamp meter. If the current is balanced and the OPHL fault still exists, return to the factory for repair.		
Check if the drive capacity is larger than the motor capacity	Choose the drive that matches the motor capacity		

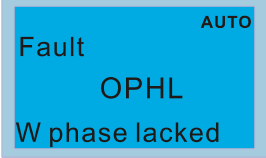
ID*	Display on LCM Keypad	Fault Name	Fault Descriptions
84		Output phase loss W phase (OPHL)	W phase output phase loss
<b>Action and Reset</b>			
Action level	Pr. 06-47		
Action time	Pr. 06-46 Pr. 06-48: Use the setting value of Pr. 06-48 first. If DC braking function activates, use that of Pr. 06-46.		
Fault treatment parameter	Pr. 06-45 0: Warn and keep operation 1: Warn and ramp to stop 2: Warn and coast to stop 3: No warning		
Reset method	Manual reset		
Reset condition	Immediately reset		
Record	When Pr. 06-45=1 or 2, OPHL is a "Fault", and the fault is recorded.		
Cause	<b>Corrective Actions</b>		
Unbalanced three-phase impedance of the motor	Replace the motor.		
Check if the wiring is incorrect	Check the cable and replace it if necessary.		
Check if the motor is a single-phase motor	Choose a three-phase motor.		
Check if the current sensor is broken	Check if the control board cable is loose. If yes, reconnect the cable and run the drive to test. If the fault still exists, return to the factory for repair. Check if the three-phase current is balanced with a current clamp meter. If the current is balanced and the OPHL fault still exists, return to the factory for repair.		
Check if the drive capacity is larger than the motor capacity	Choose the drive that matches the motor capacity		

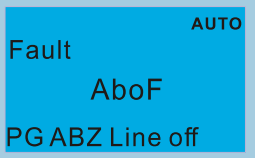

ID*	Display on LCM Keypad	Fault Name	Fault Descriptions
85		PG ABZ line off (AboF)	The ABZ line off for protection when using PG02U
<b>Action and Reset</b>			
Action level		Hardware detection	
Action time		Immediately act	
Fault treatment parameter		N/A	
Reset method		Manual reset	
Reset condition		Immediately reset	
Record		Yes	
<b>Cause</b>		<b>Corrective Actions</b>	
The PG signal cable is not connected or cut off		Check the PG signal cable	
PG card screw is loose		Tighten all the screws	
Malfunction caused by interference		Verify the wiring/grounding of the main circuit, control circuit and encoder to prevent interference.	
Hardware failure		<ol style="list-style-type: none"> <li>1. After you check the wiring, if AboF fault still exists after cycle the power, return to the factory for repair.</li> <li>2. Check if the VP power of PG card has no output, or the output voltage level is abnormal.</li> <li>3. Check if the encoder is broken.</li> </ol>	
Encoder wiring is too long, causing large voltage drop of PG card VP power.		<ol style="list-style-type: none"> <li>1. Decrease the wiring length.</li> <li>2. Power on the encoder by other power sources.</li> </ol>	

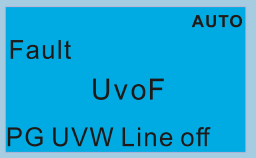
ID*	Display on LCM Keypad	Fault Name	Fault Descriptions
86		PG UVW line off (UvoF)	UVW line off for protection when using PG02U
<b>Action and Reset</b>			
Action level		Hardware detection	
Action time		Immediately act	
Fault treatment parameter		N/A	
Reset method		Manual reset	
Reset condition		Immediately reset	
Record		Yes	
<b>Cause</b>		<b>Corrective Actions</b>	
The PG signal cable is not connected or cut off		Check the PG signal cable	
PG card screw is loose		Tighten all the screws	
Malfunction caused by interference		Verify the wiring/grounding of the main circuit, control circuit and encoder to prevent interference.	
Hardware failure		<ol style="list-style-type: none"> <li>After you check the wiring, if AboF fault still exists after cycle the power, return to the factory for repair.</li> <li>Check if the VP power of PG card has no output, or the output voltage level is abnormal.</li> <li>Check if the encoder is broken.</li> </ol>	
Encoder wiring is too long, causing large voltage drop of PG card VP power.		<ol style="list-style-type: none"> <li>Decrease the wiring length.</li> <li>Power on the encoder by other power sources.</li> </ol>	

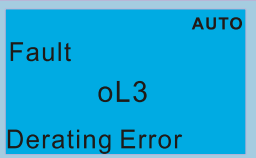
ID*	Display on LCM Keypad	Fault Name	Fault Descriptions
87		Overload protection at low frequency (oL3)	Low frequency and high current protection
<b>Action and Reset</b>			
Action level		Software detection	
Action time		Immediately act	
Fault treatment parameter		N/A	
Reset method		Manual reset	
Reset condition		Immediately reset	
Record		Yes	
<b>Cause</b>		<b>Corrective Actions</b>	
The drive operates in the low frequency range (High HP: below 15 Hz; Low HP: below 5 Hz) and IGBT temperature (High HP: 20°C; Low HP: 50°C)		<ol style="list-style-type: none"> <li>Reduce the ambient temperature of the operating drive.</li> <li>Replace the drive with a larger power model.</li> <li>Reset drive parameters or decrease carrier frequency.</li> <li>If the drive operates in V/F control mode, reduce the output voltage for low-frequency operation.</li> <li>If the drive operates in IMVF and PMSVC control mode, decrease the torque compensation gain (Pr.07-26).</li> </ol>	

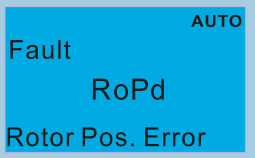
ID*	Display on LCM Keypad	Fault Name	Fault Descriptions
89		Rotor position detection error (RoPd)	Rotor position detection error protection
<b>Action and Reset</b>			
Action level		Reset the software	
Action time		Immediately act	
Fault treatment parameter		N/A	
Reset method		Manual reset	
Reset condition		Immediately reset	
Record		Yes	
<b>Cause</b>		<b>Corrective Actions</b>	
Check if the motor cable is abnormal or broken		Check or replace the cable.	
Motor coil error		Replace the motor.	
Hardware failure		IGBT broken. Return to the factory for repair.	
Drive's current feedback line error		Cycle the power. If RoPd still occurs during operation, return to the factory for repair.	

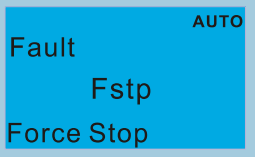
ID*	Display on LCM Keypad	Fault Name	Fault Descriptions
90		Force to stop (FStp)	Keypad forces PLC to Stop
<b>Action and Reset</b>			
Action level		When Pr. 00-32=1, STOP button on the keypad is valid. When giving the STOP command during the PLC operation, FStp fault will active.	
Action time		Immediately act	
Fault treatment parameter		N/A	
Reset method		Manual reset	
Reset condition		Immediately reset	
Record		Yes	
<b>Cause</b>		<b>Corrective Actions</b>	
Pr. 00-32=1: keypad STOP button is valid		Check if it is necessary to set Pr. 00-32=0, so the keypad STOP button is invalid.	
Press STOP button during PLC operation		Verify the timing of STOP function.	

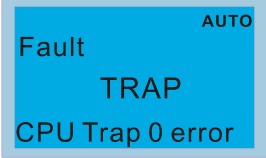
ID*	Display on LCM Keypad	Fault Name	Fault Descriptions
93		CPU error 0 (TRAP)	CPU crash
<b>Action and Reset</b>			
Action level		Hardware detection	
Action time		Immediately act	
Fault treatment parameter		N/A	
Reset method		Cannot reset, power off.	
Reset condition		N/A	
Record		Yes	
Cause		<b>Corrective Actions</b>	
Hardware interference		Verify the wiring of control circuit, and the wiring/grounding of the main circuit to prevent interference. If TRAP fault still exists, return to the factory for repair.	
Hardware failure		Return to the factory for repair.	
CPU is in an infinite loop		Cycle the power. If the TRAP fault still exists, return to the factory for repair.	

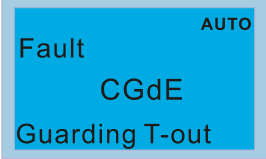
ID*	Display on LCM Keypad	Fault Name	Fault Descriptions
101		CANopen guarding error (CGdE)	CANopen guarding error
<b>Action and Reset</b>			
Action level		When CANopen Node Guarding detects that one of the slaves does not response, the CGdE fault will activate. The upper unit sets factor and time during configuration.	
Action time		The time that upper unit sets during configuration	
Fault treatment parameter		N/A	
Reset method		Manual reset	
Reset condition		The upper unit sends a reset package to clear this fault	
Record		Yes	
Cause		<b>Corrective Actions</b>	
The guarding time is too short, or less detection times		Increase the guarding time (Index 100C) and detection times	
Malfunction caused by interference		<ol style="list-style-type: none"> <li>1. Verify the wiring and grounding of the communication circuit. It is recommended to separate the communication circuit from the main circuit, or wire in 90 degree for effective anti-interference performance.</li> <li>2. Make sure the communication circuit is wired in series.</li> <li>3. Use CANopen cable or add terminating resistance.</li> </ol>	
Communication cable is broken or bad connected		Check or replace the communication cable.	

ID*	Display on LCM Keypad	Fault Name	Fault Descriptions
102		CANopen heartbeat error (CHbE)	CANopen heartbeat error
<b>Action and Reset</b>			
Action level	When CANopen Heartbeat detects that one of the slaves does not response, the CHbE fault will activate. The upper unit sets the confirming time of producer and consumer during configuration.		
Action time	The confirming time that upper unit sets for producer and consumer during configuration.		
Fault treatment parameter	N/A		
Reset method	Manual reset		
Reset condition	The upper unit sends a reset package to clear this fault		
Record	Yes		
<b>Cause</b>	<b>Corrective Actions</b>		
The heartbeat time is too short	Increase heartbeat time (Index 100C)		
Malfunction caused by interference	<ol style="list-style-type: none"> <li>1. Verify the wiring and grounding of the communication circuit. It is recommended to separate the communication circuit from the main circuit, or wire in 90 degree for effective anti-interference performance.</li> <li>2. Make sure the communication circuit is wired in series.</li> <li>3. Use CANopen cable or add terminating resistance.</li> </ol>		
Communication cable is broken or bad connected	Check or replace the communication cable.		

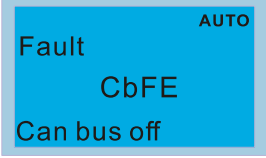
ID*	Display on LCM Keypad	Fault Name	Fault Descriptions
104		CANopen bus off error (CbFE)	CANopen bus off error
<b>Action and Reset</b>			
Action level		Hardware	When CANopen card is not installed, CbFE fault will occur.
		Software	When the master received wrong communication package, CbFE fault will occur. Too much interference on BUS When the CAN_H and CAN_L communication cable is short, the master will receive wrong package, and CbFE fault will occur.
Action level		Immediately act	
Fault treatment parameter		N/A	
Reset method		Manual reset	
Reset condition		Cycle the power	
Record		Yes	
Cause		<b>Corrective Actions</b>	
Check if the CANopen card is installed		Make sure the CANopen card is installed.	
Check if the CANopen speed is correct		Reset CANopen speed (Pr. 09-37)	
Malfunction caused by interference		<ol style="list-style-type: none"> <li>1. Verify the wiring and grounding of the communication circuit. It is recommended to separate the communication circuit from the main circuit, or wire in 90 degree for effective anti-interference performance.</li> <li>2. Make sure the communication circuit is wired in series.</li> <li>3. Use CANopen cable or add terminating resistance.</li> </ol>	
Communication cable is broken or bad connected		Check or replace the communication cable.	

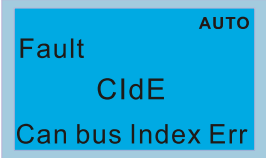
ID*	Display on LCM Keypad	Fault Name	Fault Descriptions
105		CANopen index error (CIdE)	CANopen index error
<b>Action and Reset</b>			
Action level		Software detection	
Action time		Immediately act	
Fault treatment parameter		N/A	
Reset method		Manual reset	
Reset condition		Upper unit sends a reset package to clear this fault	
Record		Yes	
Cause		<b>Corrective Actions</b>	
Incorrect setting of CANopen index		Reset CANopen Index (Pr. 00-02=7)	

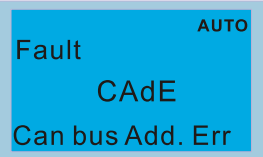
ID*	Display on LCM Keypad	Fault Name	Fault Descriptions
106		CANopen station address error (CADE)	CANopen station address error (only supports 1 – 127)
<b>Action and Reset</b>			
Action level		Software detection	
Action time		Immediately act	
Fault treatment parameter		N/A	
Reset method		Manual reset (Pr. 00-02=7)	
Reset condition		N/A	
Record		Yes	
Cause		<b>Corrective Actions</b>	
Incorrect setting of CANopen station address		<ol style="list-style-type: none"> <li>1. Disable CANopen (Pr. 09-36=0)</li> <li>2. Reset CANopen (Pr. 00-02=7)</li> <li>3. Reset CANopen station address (Pr. 09-36)</li> </ol>	

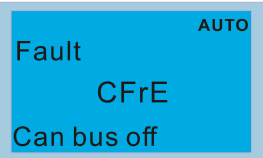
ID*	Display on LCM Keypad	Fault Name	Fault Descriptions
107		CANopen memory error (CFrE)	CANopen memory error
<b>Action and Reset</b>			
Action level		When the user update firmware version of the control board, the FRAM internal data will not be changed, and then CFrE fault will occur.	
Action time		Immediately act	
Fault treatment parameter		N/A	
Reset method		Manual reset	
Reset condition		Pr. 00-02=7	
Record		Pr. 00-21=3, the fault is recorded	
Cause		<b>Corrective Actions</b>	
CANopen internal memory error		<ol style="list-style-type: none"> <li>1. Disable CANopen (Pr. 09-36=0)</li> <li>2. Reset CANopen (Pr. 00-02=7)</li> <li>3. Reset CANopen station address (Pr. 09-36)</li> </ol>	

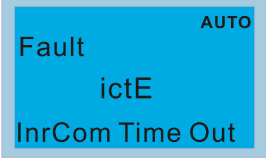
ID*	Display on LCM Keypad	Fault Name	Fault Descriptions
111		InrCOM time-out error (ictE)	Internal communication time-out
<b>Action and Reset</b>			
Action level		Pr. 09-31=-1 – -10 (there is no -9), when the internal communication between Slave and Master is abnormal, IctE fault will occur.	
Action time		Immediately act	
Fault treatment parameter		N/A	
Reset method		Automatically reset after the internal communication is normal	
Reset condition		N/A	
Record		Yes	
Cause		<b>Corrective Actions</b>	
Malfunction caused by interference		Verify the wiring and grounding of the communication circuit. It is recommended to separate the communication circuit from the main circuit, or wire in 90 degree for effective anti-interference performance.	
The communication condition is different with the upper unit		Verify the setting of Pr. 09-02 is the same as the setting of upper unit.	
Communication cable is broken or bad connected		Check or replace the communication cable.	

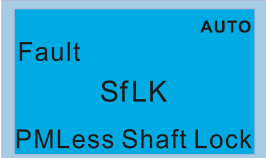
ID*	Display on LCM Keypad	Fault Name	Fault Descriptions
112		PMLess shaft lock (SfLK)	The drive has RUN command with output frequency, but the permanent magnetic motor does not turn.
<b>Action and Reset</b>			
Action level		Software detection	
Action time		3 sec.	
Fault treatment parameter		N/A	
Reset method		Manual reset	
Reset condition		Immediately reset	
Record		Yes	
Cause		<b>Corrective Actions</b>	
Improper setting of the speed observer bandwidth		Increase the setting value.	
Motor shaft lock		Remove causes of the motor shaft lock.	
Motor error (e.g. demagnetization)		Replace the motor with a new one.	

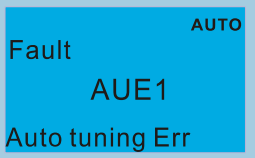

ID*	Display on LCM Keypad	Fault Name	Fault Descriptions
142		Auto-tune error 1 (AUE1)	No feedback current error when motor parameter automatically detects
<b>Action and Reset</b>			
Action level		Software detection	
Action time		Immediately act	
Fault treatment parameter		N/A	
Reset method		Manual reset	
Reset condition		Immediately reset	
Record		Yes	
Cause		<b>Corrective Actions</b>	
Motor is not wired		Wire the motor correctly	
The electromagnetic contactor is used as an open state on the output side of the drive (U/V/W).		Verify that the electromagnetic valve is closed.	

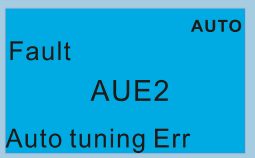
ID*	Display on LCM Keypad	Fault Name	Fault Descriptions
143		Auto-tune error 2 (AUE2)	Motor phase loss error when motor parameter automatically detects
<b>Action and Reset</b>			
Action level		Software detection	
Action time		Immediately act	
Fault treatment parameter		N/A	
Reset method		Manual reset	
Reset condition		Immediately reset	
Record		Yes	
Cause		<b>Corrective Actions</b>	
Incorrect motor wiring		Wire the motor correctly.	
Motor error		Check if the motor works normally.	
The electromagnetic contactor is used as an open state on the output side of the drive (U/V/W).		Verify that the three-phases of the electromagnetic valve are all closed.	
Motor U/V/W wire error		Check if the wires are broken.	

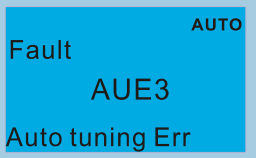
ID*	Display on LCM Keypad	Fault Name	Fault Descriptions
144		Auto-tune error 3 (AUE3)	No load current $I_0$ measurement error when motor parameter automatically detects.
<b>Action and Reset</b>			
Action level		Software detection	
Action time		Immediately act	
Fault treatment parameter		N/A	
Reset method		Manual reset	
Reset condition		Immediately reset	
Record		Yes	
Cause		<b>Corrective Actions</b>	
Incorrect settings for the motor parameter (rated current)		Check the settings for Pr. 05-01 / Pr. 05-13 / Pr. 05-34.	
Motor error		Check if the motor works normally.	

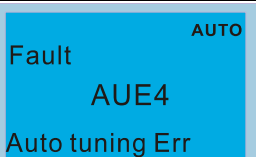
ID*	Display on LCM Keypad	Fault Name	Fault Descriptions
148		Auto-tune error 4 (AUE4)	Leakage inductance $L_{\sigma}$ measurement error when motor parameter automatically detects.
<b>Action and Reset</b>			
Action level		Software detection	
Action time		Immediately act	
Fault treatment parameter		N/A	
Reset method		Manual reset	
Reset condition		Immediately reset	
Record		Yes	
Cause		<b>Corrective Actions</b>	
Motor error		Check if the motor works normally.	
Incorrect setting of motor parameters (base frequency)		Check the setting of Pr. 01-01.	

ID*	Display on LCM Keypad	Fault Name	Fault Descriptions
170		C/B mismatch (CBM)	Control board matching error
<b>Action and Reset</b>			
Action level		N/A	
Action time		Acts when turning on the drive	
Fault treatment parameter		N/A	
Reset method		Cannot reset	
Reset condition		Cannot reset	
Record		Yes	
Cause		<b>Corrective Actions</b>	
Incorrect control board		Replace with the correct control board. If the CBM still exists, contact Delta for further confirmation.	

[This page intentionally left blank]

# ***Chapter 15 CANopen Overview***

---

- 15-1 CANopen Overview
- 15-2 Wiring for CANopen
- 15-3 CANopen Communication Interface Description
- 15-4 CANopen Supporting Index
- 15-5 CANopen Fault Code
- 15-6 CANopen LED Function

The built-in CANopen function is a kind of remote control. You can control the AC motor drive by using CANopen protocol. CANopen is a CAN-based higher layer protocol that provides standardized communication objects, including real-time data (Process Data Objects, PDO), configuration data (Service Data Objects, SDO), and special functions (Time Stamp, Sync message, and Emergency message). It also has network management data, including Boot-up message, NMT message, and Error Control message. Refer to the CiA website <http://www.can-cia.org/> for details. The content of this instruction sheet may be revised without prior notice. Consult our distributors or download the most updated version at <http://www.delta.com.tw/industrialautomation>

**Delta CANopen supporting functions:**

- Supports CAN2.0A Protocol
- Supports CANopen DS301 V4.02
- Supports DS402 V2.0.

**Delta CANopen supporting services:**

- PDO (Process Data Objects): PDO1–PDO4
- SDO (Service Data Objects):
  - Initiate SDO Download;
  - Initiate SDO Upload;
  - Abort SDO;
  - You can use the SDO message to configure the slave node and access the Object Dictionary in every node.
- SOP (Special Object Protocol):
  - Support default COB-ID in Predefined Master/Slave Connection Set in DS301 V4.02;
  - Support SYNC service;
  - Support Emergency service.
- NMT (Network Management):
  - Support NMT module control;
  - Support NMT Error control;
  - Support Boot-up.

**Delta CANopen not supporting service:**

- Time Stamp service

## 15-1 CANopen Overview

### CANopen Protocol

CANopen is a CAN-based higher layer protocol, and was designed for motion-oriented machine control networks such as handling systems. Version 4.02 of CANopen (CiA DS301) is standardized as EN50325-4. The CANopen specifications cover the application layer and communication profile (CiA DS301), as well as a framework for programmable devices (CiA DS302), recommendations for cables and connectors (CiA DS303-1), SI units, and prefix representations (CiA DS303-2).

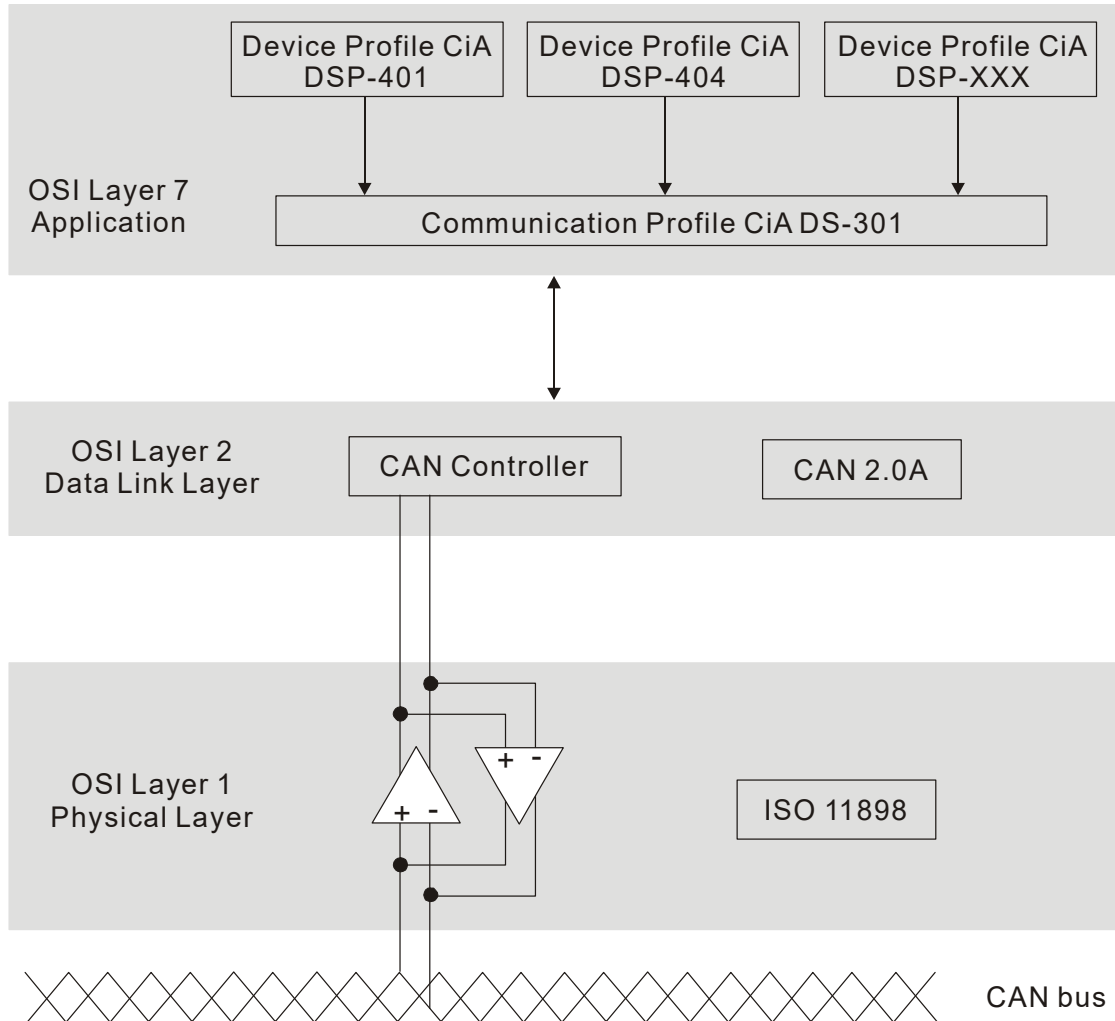

### RJ45 Pin Definition

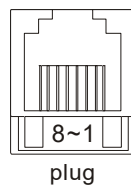

PIN	Signal	Description
1	CAN_H	CAN_H bus line (dominant high)
2	CAN_L	CAN_L bus line (dominant low)
3	CAN_GND	Ground / 0V /V-
6	CAN_GND	Ground / 0V /V-

## CANopen Communication Protocol

It has services as follows:

- NMT (Network Management Object)
- SDO (Service Data Objects)
- PDO (Process Data Object)
- EMCY (Emergency Object)

### NMT (Network Management Object)

The Network Management (NMT) follows a Master/Slave structure for executing NMT service. A network has only one NMT master, and the other nodes are slaves. All CANopen nodes have a present NMT state, and the NMT master can control the state of the slave nodes. Following shows the state diagram of a node:

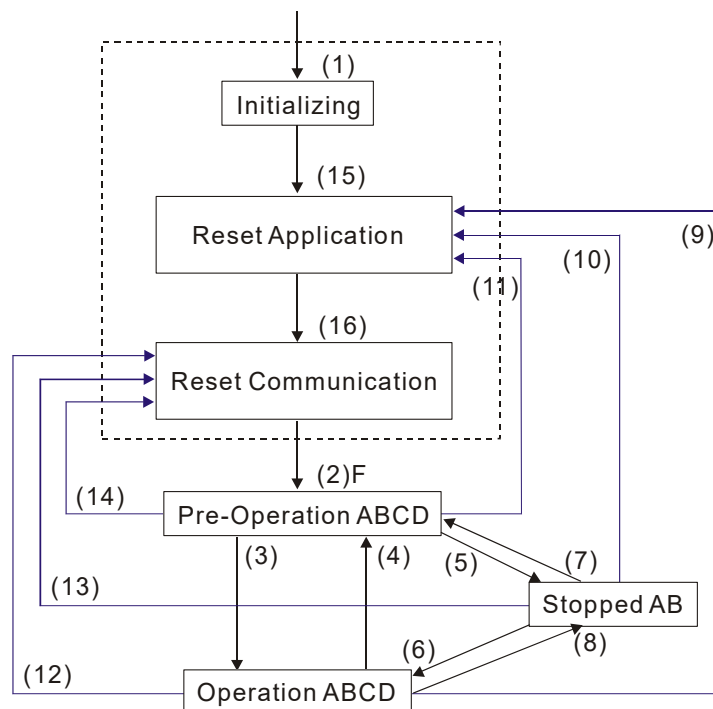

- (1) After power is applied, start in the auto-initialization state
- (2) Automatically enter the pre-operational state
- (3) (6) Start remote node
- (4) (7) Enter the pre-operational state
- (5) (8) Stop remote node
- (9) (10) (11) Reset node
- (12) (13) (14) Reset communication
- (15) Automatically enter reset application state
- (16) Automatically enter reset communication state

- A: NMT
- B: Node Guard
- C: SDO
- D: Emergency
- E: PDO
- F: Boot-up

	Initializing	Pre-Operational	Operational	Stopped
PDO			○	
SDO		○	○	
SYNC		○	○	
Time Stamp		○	○	
EMCY		○	○	
Boot-up	○			
NMT		○	○	○

## SDO (Service Data Objects)

Use SDO to access the Object Dictionary in every CANopen node using the Client/Server model. One SDO has two COB-IDs (request SDO and response SDO) to upload or download data between two nodes. There is no data limit for SDOs to transfer data, but it must transfer data by segment when the data exceeds four bytes with an end signal in the last segment.

The Object Dictionary (OD) is a group of objects in a CANopen node. Every node has an OD in the system, and OD contains all parameters describing the device and its network behavior. The access path in the OD is the index and sub-index; each object has a unique index in the OD, and has a sub-index if necessary.

## PDO (Process Data Objects)

PDO communication can be described by the producer/ consumer model. Each node of the network listens to the messages of the transmission node and distinguishes whether the message has to be processed or not after receiving the message. A PDO can be transmitted from one device to one another device or to many other devices. Every PDO has two PDO services: a TxPDO and an RxPDO. PDOs are transmitted in a non-confirmed mode. All transmission types are listed in the following table:

Type Number	PDO				
	Cyclic	Acyclic	Synchronous	Asynchronous	RTR only
0		○	○		
1–240	○		○		
241–251	Reserved				
252			○		○
253				○	○
254				○	
255				○	

Type number 0 indicates the synchronous aperiodic message between two PDO transmissions.

Type number 1–240 indicates the number of SYNC message between two PDO transmissions.

Type number 252 indicates the data is updated (but not sent) immediately after receiving SYNC.

Type number 253 indicates the data is updated immediately after receiving RTR.

Type number 254: Delta CANopen does not support this transmission format.

Type number 255 indicates the data is an asynchronous aperiodic transmission.

All PDO transmission data must be mapped to index via Object Dictionary.

## EMCY (Emergency Object)

When errors occur inside the hardware, an emergency object is triggered. An emergency object is only sent when an error occurs. As long as there is nothing wrong with the hardware, there is no emergency object warning of an error message.



## 15-2 Wiring for CANopen

Use an external adapter card EMC-COP01 for CANopen wiring to connect CANopen to a C2000. The link uses a RJ45 cable. You must terminate the two farthest ends with  $120\ \Omega$  terminating resistors as shown in the picture below.

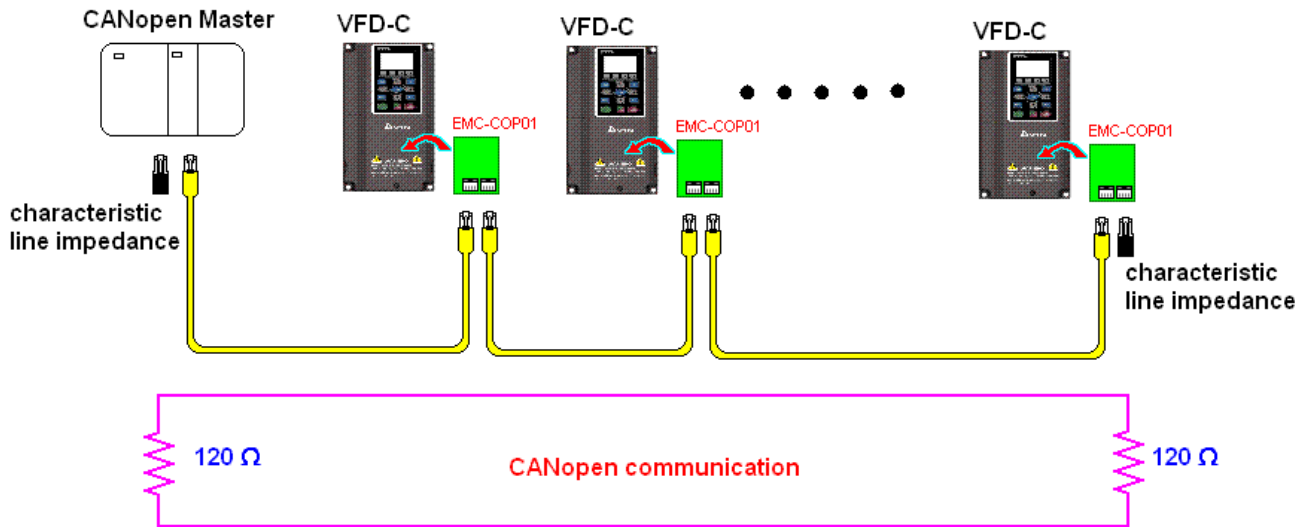

## 15-3 CANopen Communication Interface Descriptions

### 15-3-1 CANopen Control Mode Selection

There are two control modes for CANopen: the DS402 standard (Pr. 09-40 set to 1) is the default, and the Delta's standard setting (Pr. 09-40 set to 0). There are two control modes according to Delta's standard. One is the old control mode (Pr. 09-30 = 0); this control mode can only control the motor drive under frequency control. The other mode is a new standard (Pr. 09-30 = 1); this new control mode allows the motor drive to be controlled under multiple modes. The C2000 currently supports speed, torque, position and home mode. The following table shows the control mode definitions:

CANopen Control Mode Selection	Control Mode							
	Speed		Torque		Position		Home	
	Index	Description	Index	Description	Index	Description	Index	Description
DS402 standard Pr. 09-40=1	6042-00	Target Rotating Speed (RPM)	6071-00	Target Torque (%)	607A-00	Target Position	----	----
	----	----	6072-00	Max. Torque Limit (%)	----	----	----	----
Delta Standard (Old definition) Pr. 09-40=1, Pr. 09-30=0	2020-02	Target Rotating Speed (Hz)	----	----	----	----	----	----
Delta Standard (New definition) Pr. 09-40=0, Pr. 09-30=1	2060-03	Target Rotating Speed (Hz)	2060-07	Target Torque (%)	2060-05	Target Position	----	----
	2060-04	Torque Limit (%)	2060-08	Speed Limit (Hz)	----	----	----	----

CANopen Control Mode Selection	Operation Control	
	Index	Description
DS402 standard Pr. 09-40=1	6040-00	Operation Command
	----	----
Delta Standard (Old definition) Pr. 09-40=1, Pr. 09-30=0	2020-01	Operation Command
Delta Standard (New definition) Pr. 09-40=0, Pr. 09-30=1	2060-01	Operation Command
	----	----

CANopen Control Mode Selection	Other	
	Index	Description
DS402 standard Pr. 09-40=1	605A-00	Quick stop processing mode
	605C-00	Disable operation processing mode
Delta Standard (Old definition) Pr. 09-40=1, Pr. 09-30=0	----	----
Delta Standard (New definition) Pr. 09-40=0, Pr. 09-30=1	----	----
	----	----

You can use some indices in either DS402 or Delta's standard.

For example:

1. Indices that are defined as RO attributes.
2. The corresponding index of available parameter groups: (2000-00–200B-XX)
3. Accelerating / Decelerating Index: 604F 6050

## 15-3-2 DS402 Standard Control Mode

### 15-3-2-1 Related set up for an AC motor drive (following the DS402 standard)

If you want to use the DS402 standard to control the motor drive, follow these steps:

1. Wire the hardware (refer to Section 15-2 Wiring for CANopen)
2. Set the operation source: set Pr.00-21 to 3 for CANopen communication card control. (Run/stop, forward/ reverse run...etc.)
3. Set the frequency source: set Pr.00-20 to 6. Choose the source for the Frequency command from the CANopen setting.
4. Set the torque source: set Pr. 11-33. Choose the source for the Torque command from the CANopen setting.
5. Set the position source: set Pr. 11-40. Choose the source for the Position command from the CANopen setting.
6. Set DS402 for the control mode: Pr. 09-40=1
7. Set the CANopen station: set the CANopen station (range 1–127, 0 is the disable CANopen slave function) with Pr.09-36. Note: set Pr.00-02 = 7 to reset if the station number error CADE or CANopen memory error CFE appears.
8. Set the CANopen baud rate: set Pr. 09-37 (CANBUS Baud Rate: 1Mbps(0), 500Kbps(1), 250Kbps(2), 125Kbps(3), 100Kbps(4) and 50Kbps(5))
9. Set the multiple input functions to Quick Stop. You can also choose enable or disable; the default setting is disabled. If it is necessary to enable the function, set MI terminal to 53 in one of the following parameters: Pr. 02.01–Pr. 02.08 or Pr. 02.26–Pr. 02.31. (Note: This function is available in DS402 only.)

### 15-3-2-2 The status of the motor drive (by following DS402 standard)

According to the DS402 definition, the motor drive is divided into 3 blocks and 9 statuses as described below.

#### **3 blocks**

1. Power Disable: without PWM output
2. Power Enable: with PWM output
3. Fault: One or more errors have occurred.

#### **9 status**

1. Start: Power On
2. Not ready to switch on: the motor drive is initiating.
3. Switch On Disable: occurs when the motor drive finishes initiating.
4. Ready to Switch On: warming up before running.
5. Switch On: the motor drive has the PWM output, but the reference command is not effective.
6. Operation Enable: able to control normally.
7. Quick Stop Active: when there is a Quick Stop request, stop running the motor drive.
8. Fault Reaction Active: the motor drive detects conditions that might trigger error(s).
9. Fault: One or more errors have occurred in the motor drive.

When the motor drive turns on and finishes the initiation, it remains in Ready to Switch On status. To control the operation of the motor drive, change to Operation Enable status. To do this, set the control word's bit0-bit3 and bit7 of the Index 6040H and pair with Index Status Word (Status Word 0X6041). The control steps and index definition are described below:

Index 6040

15-9	8	7	6~4	3	2	1	0
Reserved	Halt	Fault Reset	Operation	Enable operation	Quick Stop	Enable Voltage	Switch On

Index 6041

15-14	13-12	11	10	9	8	7	6	5	4	3	2	1	0
Reserved	Operation	Internal limit active	Target reached	Remote	Reserved	Warning	Switch on disabled	Quick stop	Voltage enabled	Fault	Operation enable	Switch on	Ready to switch on

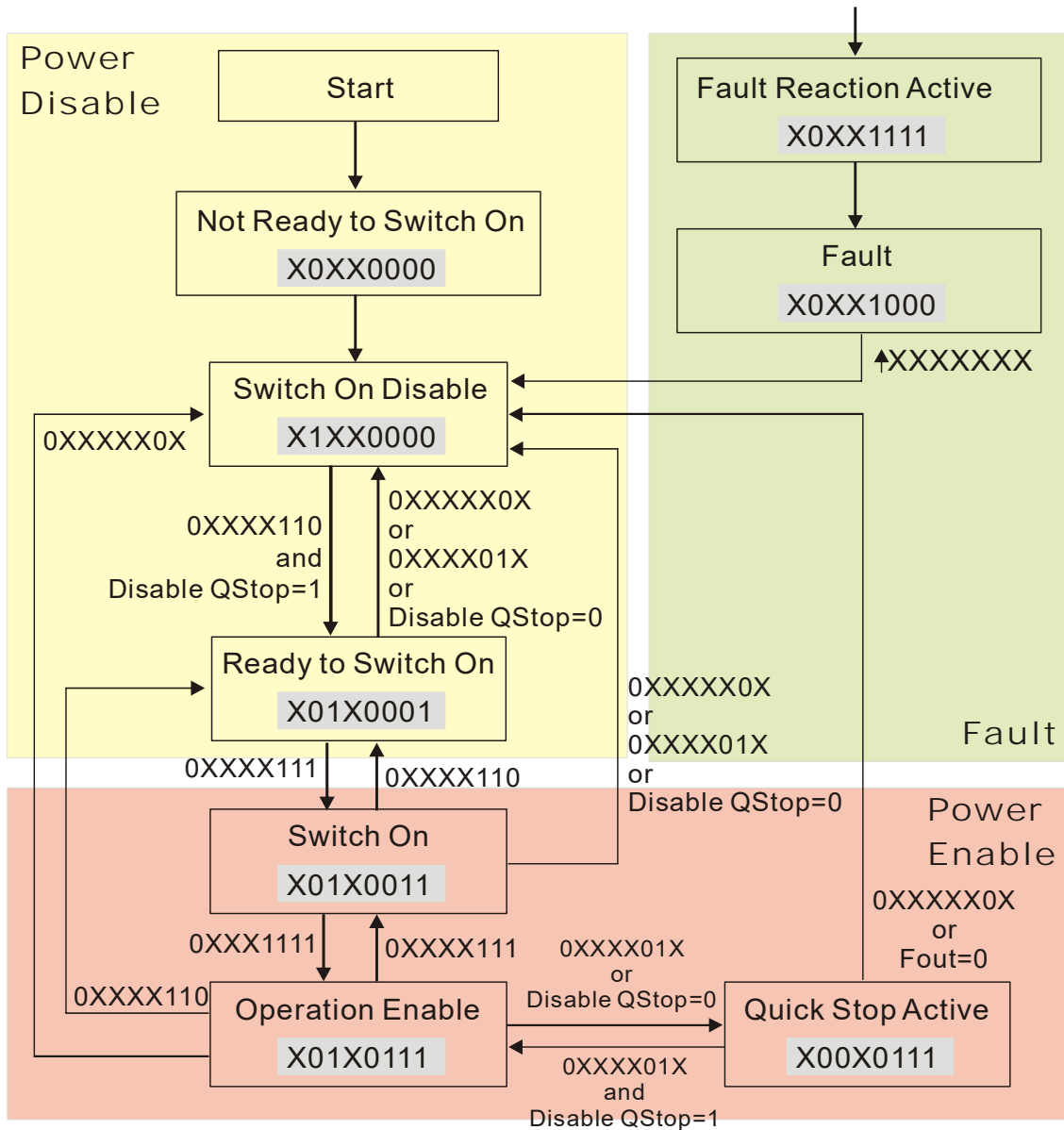

Set command 6040=0xE, then set another command 6040=0xF. Then you can switch the motor drive to Operation Enable. The Index 605A determines the lines from Operation Enable when the control mode changes from Quick Stop Active. When the setting value is 1-3, both lines are active, but when the setting value of 605A is not 1-3, once the motor drive is switched to Quick Stop Active, it is not able to switch back to Operation Enable.)

Index	Sub	Definition	Default	R/W	Size	Unit	PDO Map	Mode	note
605Ah	0	Quick stop option code	2	RW	S16		No		0: Disable drive function
									1: Slow down on slow down ramp
									2: Slow down on quick stop ramp
									5: Slow down on slow down ramp and stay in QUICK STOP
									6: Slow down on quick stop ramp and stay in QUICK STOP
7: Slow down on the current limit and stay in Quick stop									

When the control section switches from Power Enable to Power Disable, use 605C to define the stop method.

Index	Sub	Definition	Default	R/W	Size	Unit	PDO Map	Mode	note
605Ch	0	Disable operation option code	1	RW	S16		No		0: Disable drive function 1: Slow down with slow down ramp; disable the drive function

### 15-3-2-3 Various mode control method (by following DS402 standard)

The control mode of C2000 currently supports speed, torque, position and home control, and are described as below:

#### Speed mode

1. Set C2000 to speed control mode: set Index 6060 to 2.  
(The Index 6071 is available for torque limit under the speed control mode)
2. Switch to Operation Enable mode: set 6040=0xE, and then set 6040 = 0xF.
3. Set the target frequency: Set target frequency of 6042, since the operation unit of 6042 is rpm, a transform is required:

$$n = f \times \frac{120}{p}$$

n: rotation speed (rpm) (rounds/minute)  
p: motor's pole number (Pole)  
f: rotation frequency (Hz)

For example:

Set 6042H = 1500 (rpm), if the number of poles is 4 (Pr. 05-04 or Pr. 05-16), then the motor drive's operation frequency is 1500/ (120/4) = 50Hz. The 6042 is defined as a signed operation.

The plus or minus sign means to rotate clockwise or counter clockwise

4. To set acceleration and deceleration: Use 604F (Acceleration) and 6050 (Deceleration).
5. Trigger an ACK signal: in the speed control mode, the bit 6–4 of Index 6040 needs to be controlled.

It is defined as below:

Speed mode (Index 6060=2)	Index 6040			SUM
	bit 6	bit 5	bit 4	
	1	0	1	Locked at the current signal.
	1	1	1	Run to reach targeting signal.
	Other			Decelerate to 0Hz.

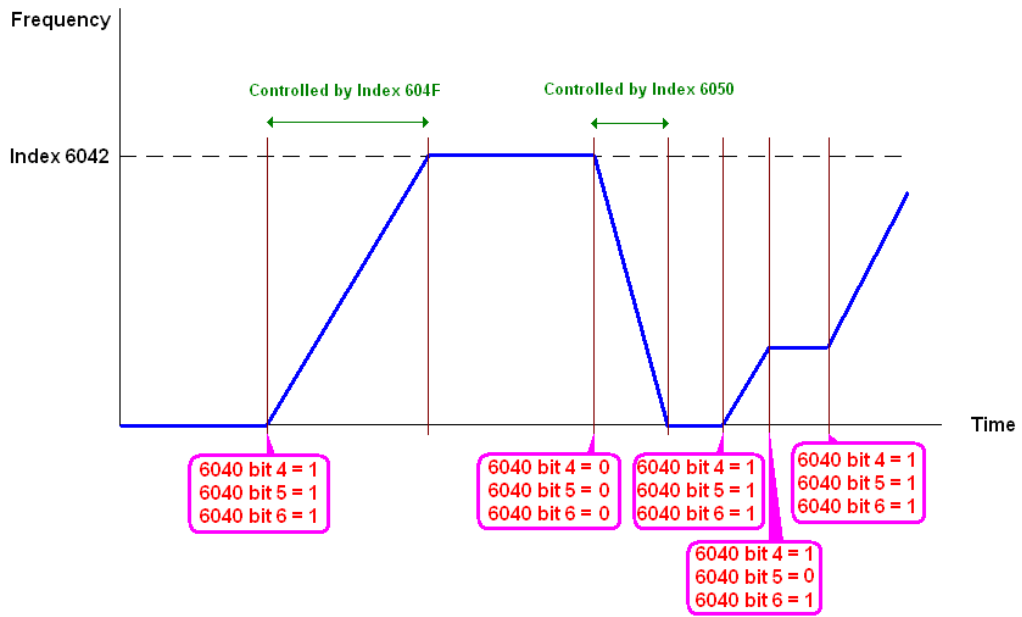

NOTE 01: Read 6043 to get the current rotation speed. (Unit: rpm)

NOTE 02: Read bit 10 of 6041 to find if the rotation speed has reached the targeting value. (0: Not reached; 1: Reached)

### Torque mode

1. Set AC motor drive to the torque mode: set Index 6060 = 4.  
(The Index 6042 is available for speed limit under the torque control mode)
2. Switch to Operation Enable mode: set 6040 = 0xE, and then set 6040 = 0xF.
3. To set targeting torque: set 6071 as targeting torque and 6072 as the largest output torque.

Torque mode (Index 6060=4)	Index 6040			SUM
	bit6	bit5	bit4	
	X	X	X	RUN to reach the targeting torque.

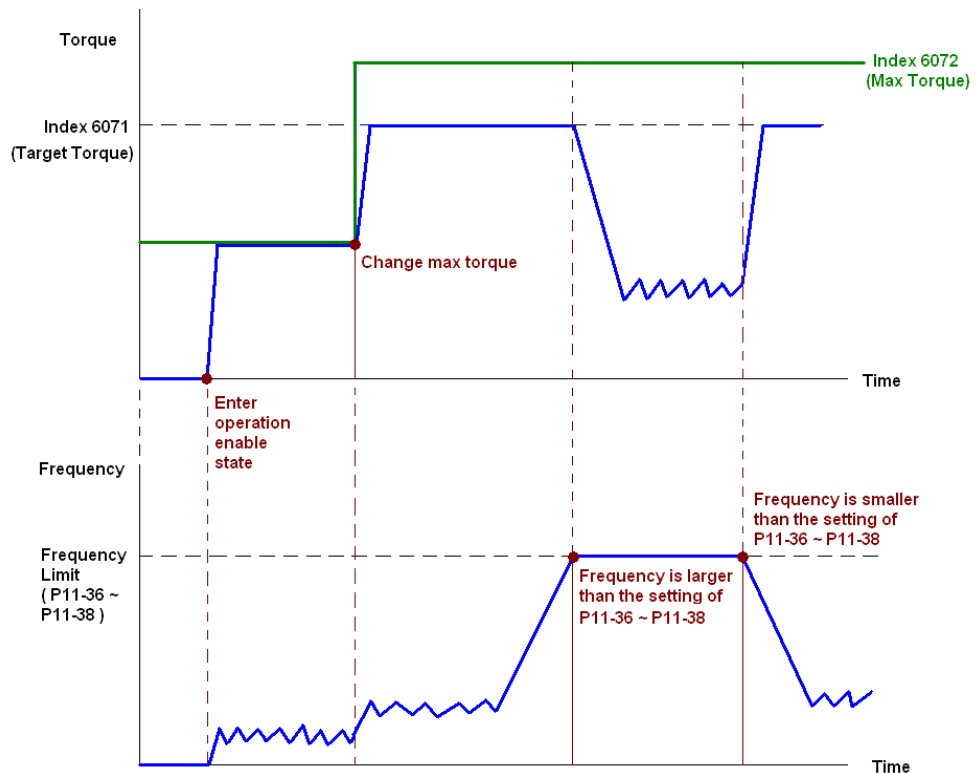

NOTE: The standard DS402 does not regulate the maximum speed limit. Therefore, if the motor drive defines the control mode of DS402, the highest speed will go with the setting of Pr. 11-36 to Pr. 11-38.

NOTE 01: Read 6077 to get the current torque. (Unit: 0.1%).

NOTE02: Read bit10 of 6041 to find if the torque has reached the targeting value. (0: Not reached; 1: Reached)

### Position mode

1. Set the parameter of a trapezium curve to define position control (Pr. 11-43 Max. Frequency of Point-to-Point Position Control, Pr. 11-44 Accel. Time of Point-to-Point Position Control and Pr. 11-45 Decel. Time of Point-to-Point Position Control)
2. Set C2000 to position control mode: set Index 6060 = 1.
3. Switch to Operation Enable mode: set 6040 = 0xE, and then set 6040 = 0xF.
4. Set targeting position: set 607A as the targeting position.
5. Trigger an ACK signal: set 6040 = 0x0F, and then set 6040 = 0x1F. (Pulse On).

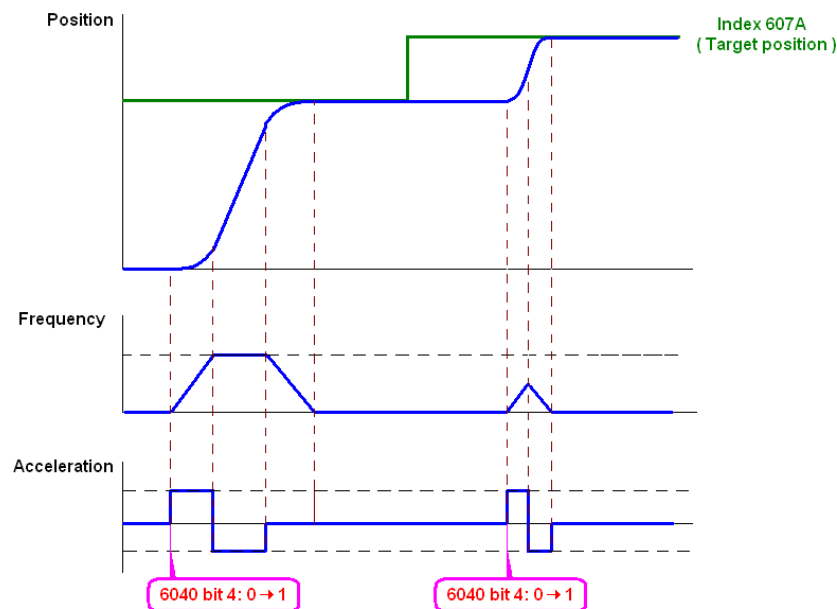

NOTE 01: Read 6064 to get the current position.

NOTE 02: Read bit10 of 6041 to find if the position reaches the targeting position. (0: Not reached, 1: reached)

NOTE 03: Read bit11 of 6041 to find if the position is over the limited area. (0: in the limit, 1: over the limit)

### Home mode

1. Set Pr. 00-12 to choose a home method.
2. Set the left and right limits correspond to the position of MI terminal.
3. Switch to Home mode: set Index 6060 = 6.
4. Switch to Operation Enable mode: set 6040 = 0xE, and then set 6040 = 0xF.
5. To trigger an ACK signal: set 6040 = 0x0F, and then set 6040 = 0x1F (Pulse On, and the motor drive will be back to home.)

NOTE 01: Read bit12 of 6041 to find if the home mode is completed. (0: Not reached, 1: reached)

## 15-3-3 Using the Delta Standard (Old definition, only supports speed mode)

## 15-3-3-1 Various mode control method (Delta Old Standard)

Follow the steps below:

1. Wire the hardware (refer to Section 15-2 Wiring for CANopen).
2. Set the operation source: set Pr. 00-21 to 3 for CANopen communication card control. (Run/stop, Forward/ reverse run....., etc.)
3. Set the frequency source: set Pr. 00-20 to 6. Choose source for the Frequency Command from the CANopen setting.
4. Set Delta Standard (Old definition, only supports speed mode) as the control mode: Pr. 09-40 = 0 and Pr. 09-30 = 0.
5. Set the CANopen station: set Pr. 09-36; the range is among 1–127. When Pr. 09-36=0, the CANopen slave function is disabled. Note: If an error appears (CAeE or CANopen memory error) as you complete the station setting, set Pr.00-02 = 7 to reset.
6. Set the CANopen baud rate: set Pr. 09-37 (CANBUS Baud Rate: 1Mbps(0), 500Kbps(1), 250Kbps(2), 125Kbps(3), 100Kbps(4) and 50Kbps(5))

## 15-3-3-2 By speed mode

1. Set the target frequency: set 2020-02, the unit is Hz, with 2 decimal places. For example, 1000 is 10.00Hz.
2. Operation control: set 2020-01 = 0002H for running, and set 2020-01 = 0001H for stopping.

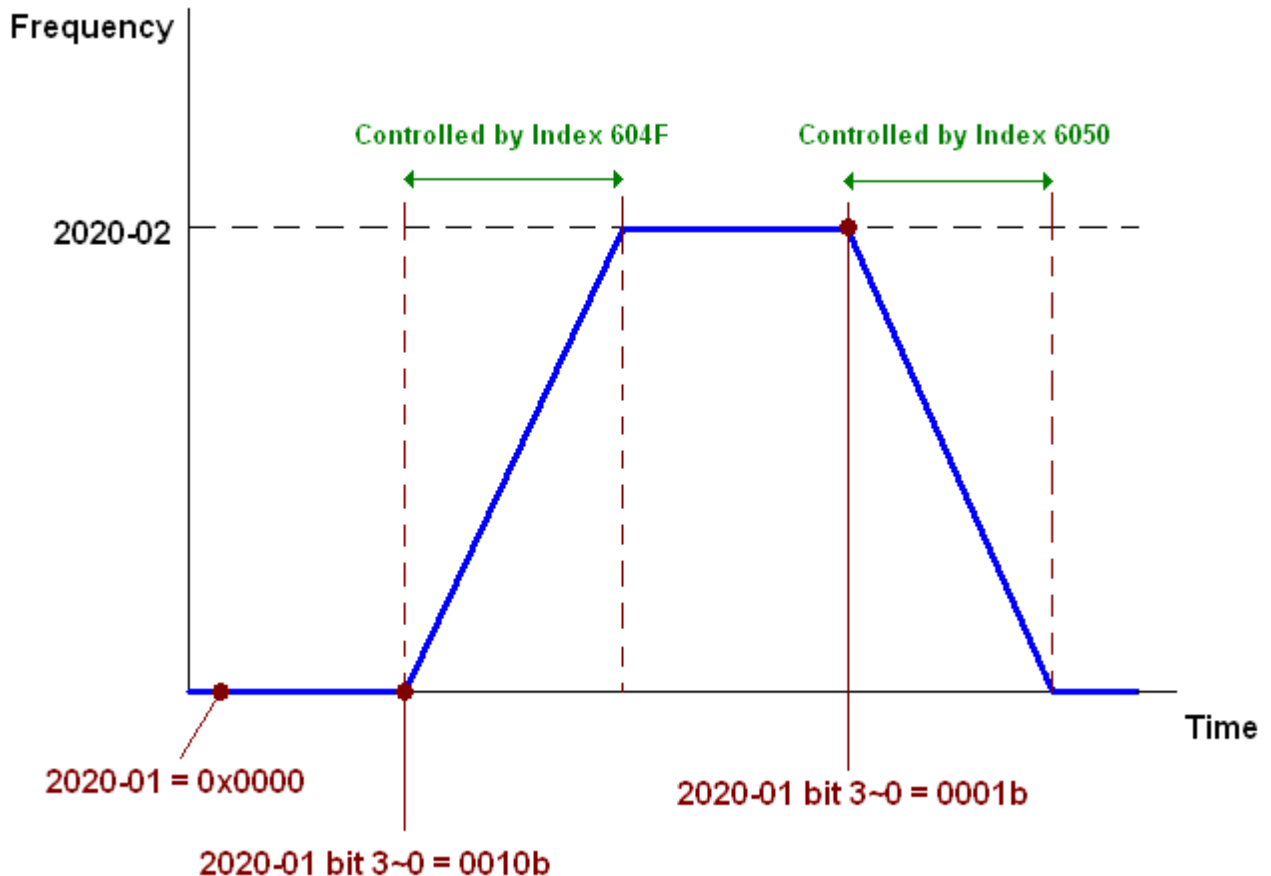



### 15-3-4 Using Delta Standard (New Definition)

#### 15-3-4-1 Related set up for an AC motor drive (Delta New Standard)

Follow the steps below:

1. Wire the hardware (refer to Section 15-2 Wiring for CANopen).
2. Set the operation source: set Pr. 00-21 to 3 for CANopen communication card control. (Run/stop, Forward/ reverse run....., etc.)
3. Set the frequency source: set Pr. 00-20 to 6. Choose the source of the Frequency Command from CANopen setting.
4. Set the torque source: set Pr. 11-33. Choose the source of the Torque Command from CANopen setting.)
5. Set the position source: set Pr.11-40=3. Choose the source of the Position Command from CANopen setting.)
6. Set Delta Standard (New definition) as the control mode: Pr. 09-40 = 0 and Pr. 09-30 = 0.
7. Set the CANopen station: set Pr. 09-36; the range is among 1–127. When Pr. 09-36=0, the CANopen slave function is disabled. (Note: If an error appears (CadE or CANopen memory error) as you complete the station setting, set Pr.00-02 = 7 to reset.
8. Set the CANopen baud rate: set Pr. 09-37 (CANBUS Baud Rate: 1Mbps(0), 500Kbps(1), 250Kbps(2), 125Kbps(3), 100Kbps(4) and 50Kbps(5))

#### 15-3-4-2 Various mode control method (Delta New Standard)

##### Speed Mode

1. Set C2000 to speed control mode: set Index6060 = 2.
2. Set the target frequency: set 2060-03, unit is Hz, with 2 decimal places. For example, 1000 is 10.00Hz.
3. Operation control: set 2060-01 = 008H for Server on, and set 2060-01 = 0081H for running.

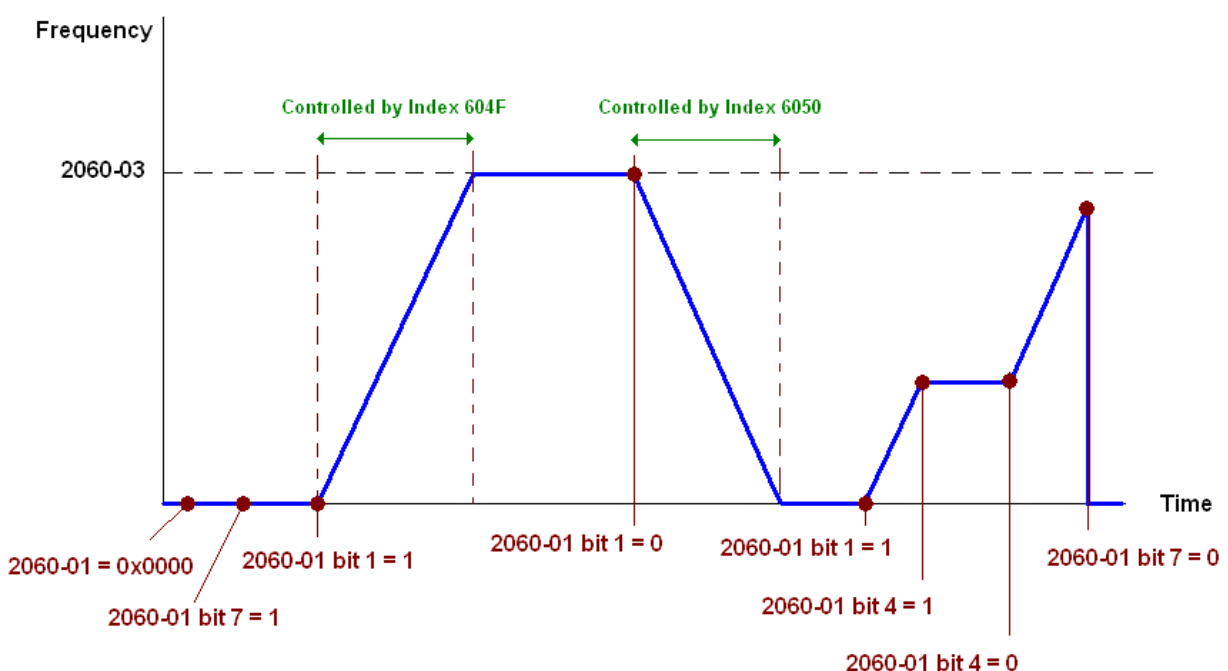

## Torque Mode

1. Set C2000 to torque control mode: set Index 6060 = 4.
2. Set the target torque: set 2060-07, unit as %, and the value is one decimal place. For example, 100 is 10.0%.
3. Operation control: set 2060-01 = 0080H starts excitation, and the drive immediately runs at the target torque.

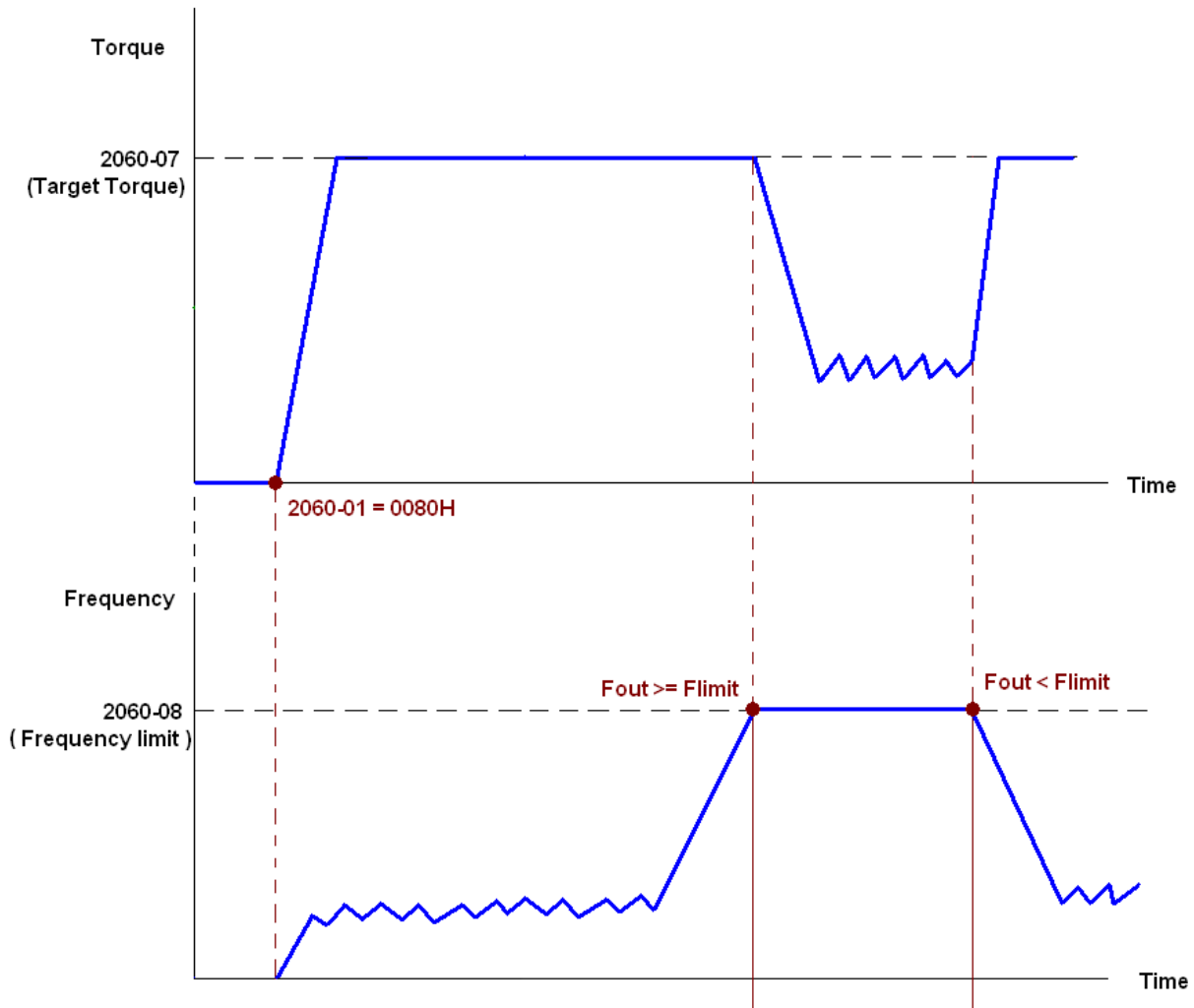

Note01: Read 2061-07 for the current torque (unit is 0.1%).

Note02: Read bit0 of 2061-01 to find if the torque has reached the set value (0: Not reached, 1: Reached).

Note 03: If the speed of the drive reaches the speed limit when torque outputs, you may reduce the output torque in order to ensure that the speed stays within the limits.

## Position Mode

1. Set the parameter of a trapezium curve to define position control (Pr. 11-43 Max. Position Control Frequency), Pr. 11-44 Accel. Time of Position Control, Pr. 11-45 Decel. Time of Position Control)
2. Set C2000 to position control mode, set Index 6060 = 1.
3. Set 2060-01 = 0080h, then motor drive starts excitation.
4. Set target position: set 2060-05 = target position.
5. Set 2060-01 = 0081h to trigger the motor drive runs to the target position.
6. Repeat step 3 to step 5 to move to another position.

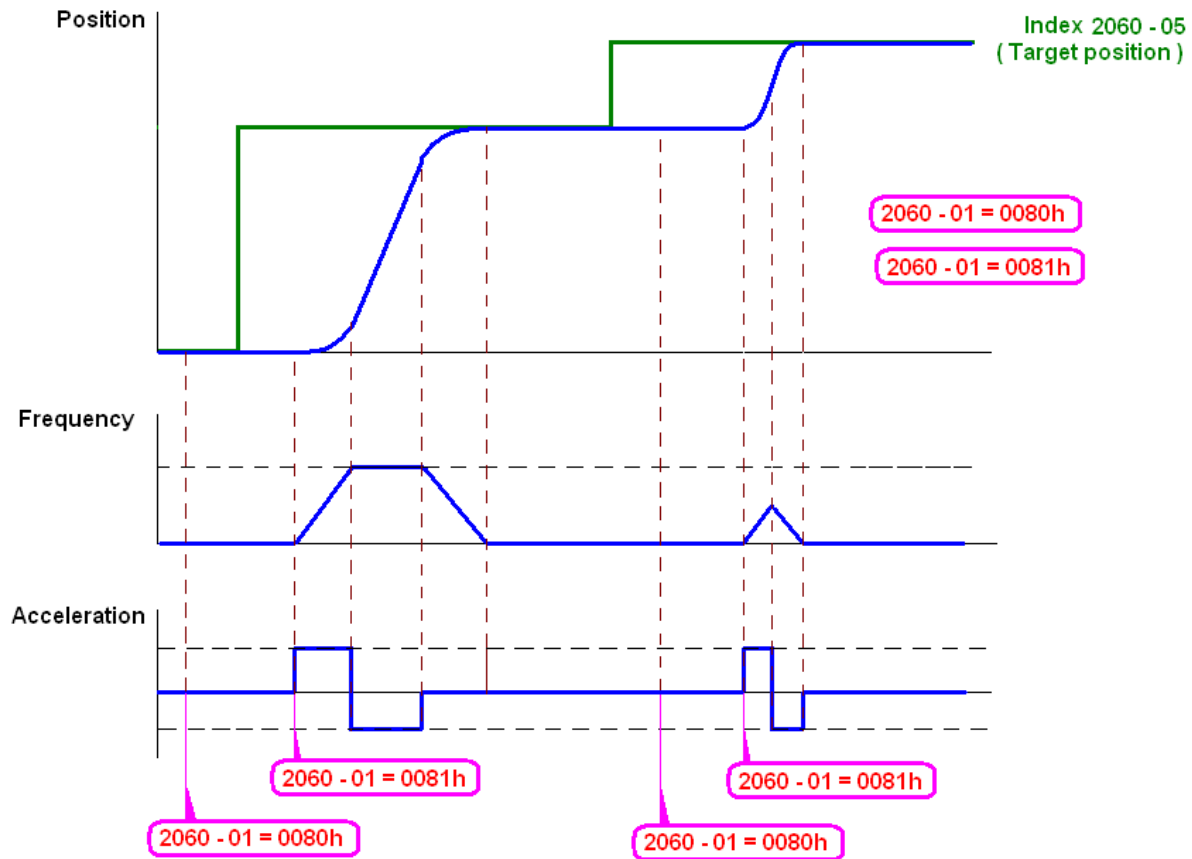

NOTE01: Read 2061-05 to get the current position.

NOTE02: Read bit0 of 2061 to find if the position has reached to the target position. (0: Not reached, 1: Reached).

**Home Mode**

1. Set Pr. 00-12 to choose the method to return home.
2. Set the left and right limits correspond to the position of MI terminal.
3. Switch to home mode: set Index 6060 = 6.
4. Set 2060-01 = 0080h, then the motor drive starts excitation.
5. Set the ACK signal: set 2060-01 = 0081h, then the motor drive starts to go back home.

NOTE 01: Read bit12 of 6041 to find if returning home is completed. (0: Not reached, 1: Reached).

## 15-3-5 DI/DO AI/AO are controlled through CANopen

To control the DO/AO of the motor drive through CANopen, follow the steps below:

1. Define the DO to be controlled by CANopen. For example, set Pr. 02-14 to control RY2.
2. Define the AO to be controlled by CANopen. For example, set Pr. 03-23 to control AFM2.
3. Control the mapping index of CANopen. To control DO, use control index 2026-41. To control AO, you will need to control 2026-AX. To set RY2 as ON, set bit1 of Index 2026-41 =1, then RY2 outputs 1. To control AFM2 output = 50.00%, set Index 2026-A2 =5000, then AFM2 outputs 50%.

The following table shows the mapping of CANopen DI/ DO/ AI/ AO:

DI:

Terminal	Related Parameters	R/W	Mapping Index
FWD	==	RO	2026-01 bit0
REV	==	RO	2026-01 bit1
MI1	==	RO	2026-01 bit2
MI2	==	RO	2026-01 bit3
MI3	==	RO	2026-01 bit4
MI4	==	RO	2026-01 bit5
MI5	==	RO	2026-01 bit6
MI6	==	RO	2026-01 bit7
MI7	==	RO	2026-01 bit8
MI8	==	RO	2026-01 bit9
MI10	==	RO	2026-01 bit10
MI11	==	RO	2026-01 bit11
MI12	==	RO	2026-01 bit12
MI13	==	RO	2026-01 bit13
MI14	==	RO	2026-01 bit14
MI15	==	RO	2026-01 bit15

DO :

Terminal	Related Parameters	R/W	Mapping Index
RY1	Pr. 02-13 = 50	RW	2026-41 bit0
RY2	Pr. 02-14 = 50	RW	2026-41 bit1
MO1	Pr. 02-16 = 50	RW	2026-41 bit3
MO2	Pr. 02-17 = 50	RW	2026-41 bit4
MO10	Pr. 02-36 = 50	RW	2026-41 bit5
RY10			2026-41 bit5
MO11	Pr. 02-37 = 50	RW	2026-41 bit6
RY11			2026-41 bit6
RY12	Pr. 02-38 = 50	RW	2026-41 bit7
RY13	Pr. 02-39 = 50	RW	2026-41 bit8
RY14	Pr. 02-40 = 50	RW	2026-41 bit9
RY15	Pr. 02-41 = 50	RW	2026-41 bit10

AI :

Terminal	Related Parameters	R/W	Mapping Index
AVI	==	RO	Value of 2026-61
ACI	==	RO	Value of 2026-62
AUI	==	RO	Value of 2026-63

AO :

Terminal	Related Parameters	R/W	Mapping Index
AFM1	Pr. 03-20 = 20	RW	Value of 2026-A1
AFM2	Pr. 03-23 = 20	RW	Value of 2026-A2

## 15-4 CANopen Supporting Index

C2000 Index:

The parameter index corresponds as shown in this example:

Index	sub-Index
2000H + Group	member+1

For example:

Pr. 10-15 (Encoder Slip Error Treatment)

Group	member
10(0AH)	- 15(0FH)

Index = 2000H + 0AH = 200A

Sub Index = 0FH + 1H = 10H

C2000 Control Index:

### Delta Standard Mode (Old Definition)

Index	Sub	Definition	Default	R/W	Size	Note						
2020H	0	Number	3	R	U8							
	1	Control word	0	RW	U16	bit1-0	00B: disable 01B: stop 10B: disable 11B: JOG Enable					
						bit3-2	Reserved					
						bit5-4	00B:disable 01B: Direction forward 10B: Reverse 11B: Switch Direction					
							bit7-6	00B: 1 <sup>st</sup> step Accel. /Decel. 01B: 2 <sup>nd</sup> step Accel. /Decel. 10B: 3 <sup>rd</sup> step Accel. /Decel. 11B: 4 <sup>th</sup> step Accel. /Decel.				
								bit11-8	0000B: Master speed 0001B: 1 <sup>st</sup> step speed 0010B: 2 <sup>nd</sup> step speed 0011B: 3 <sup>rd</sup> step speed 0100B: 4 <sup>th</sup> step speed 0101B: 5 <sup>th</sup> step speed 0110B: 6 <sup>th</sup> step speed 0111B: 7 <sup>th</sup> step speed 1000B: 8 <sup>th</sup> step speed 1001B: 9 <sup>th</sup> step speed 1010B: 10 <sup>th</sup> step speed 1011B: 11 <sup>th</sup> step speed 1100B: 12 <sup>th</sup> step speed 1101B: 13 <sup>th</sup> step speed 1110B: 14 <sup>th</sup> step speed 1111B: 15 <sup>th</sup> step speed			
						bit12			1: Enable the function of bit6-11			
						bit 15			Reserved			
						2	Freq. command (XXX.XXHz)		0	RW	U16	

Index	Sub	Definition	Default	R/W	Size	Note																													
	3	Other trigger	0	RW	U16	<table border="1"> <tr> <td>bit0</td> <td>1: E.F. ON</td> </tr> <tr> <td>bit1</td> <td>1: Reset</td> </tr> <tr> <td>bit2</td> <td>1: Base Block (B.B) ON</td> </tr> <tr> <td>bit15–3</td> <td>Reserved</td> </tr> </table>	bit0	1: E.F. ON	bit1	1: Reset	bit2	1: Base Block (B.B) ON	bit15–3	Reserved																					
bit0	1: E.F. ON																																		
bit1	1: Reset																																		
bit2	1: Base Block (B.B) ON																																		
bit15–3	Reserved																																		
2021H	0	Number	10	R	U8																														
	1	Error code	0	R	U16	High byte: Warn code Low byte: Error code																													
	2	AC motor drive status	0	R	U16	<table border="1"> <tr> <td rowspan="4">bit1–0</td> <td>00B: stop</td> </tr> <tr> <td>01B: decelerate to stop</td> </tr> <tr> <td>10B: waiting for operation command</td> </tr> <tr> <td>11B: in operation</td> </tr> <tr> <td>bit2</td> <td>1: JOG command</td> </tr> <tr> <td>bit4–3</td> <td>00B: Run forward</td> </tr> <tr> <td></td> <td>01B: switch from run in reverse to run forward</td> </tr> <tr> <td></td> <td>10B: switch from run forward to run in reverse</td> </tr> <tr> <td></td> <td>11B: Run in reverse</td> </tr> <tr> <td>bit7–5</td> <td>Reserved</td> </tr> <tr> <td>bit8</td> <td>1: Master Frequency command controlled by communication interface</td> </tr> <tr> <td>bit9</td> <td>1: Master Frequency command controlled by analog signal input</td> </tr> <tr> <td>bit10</td> <td>1: Operation command controlled by communication interface</td> </tr> <tr> <td>bit11</td> <td>1: Parameter lock</td> </tr> <tr> <td>bit12</td> <td>1: Enable the digital keypad copy parameter function</td> </tr> <tr> <td>bit15–13</td> <td>Reserved</td> </tr> </table>	bit1–0	00B: stop	01B: decelerate to stop	10B: waiting for operation command	11B: in operation	bit2	1: JOG command	bit4–3	00B: Run forward		01B: switch from run in reverse to run forward		10B: switch from run forward to run in reverse		11B: Run in reverse	bit7–5	Reserved	bit8	1: Master Frequency command controlled by communication interface	bit9	1: Master Frequency command controlled by analog signal input	bit10	1: Operation command controlled by communication interface	bit11	1: Parameter lock	bit12	1: Enable the digital keypad copy parameter function	bit15–13	Reserved
	bit1–0	00B: stop																																	
		01B: decelerate to stop																																	
		10B: waiting for operation command																																	
		11B: in operation																																	
	bit2	1: JOG command																																	
	bit4–3	00B: Run forward																																	
		01B: switch from run in reverse to run forward																																	
		10B: switch from run forward to run in reverse																																	
		11B: Run in reverse																																	
	bit7–5	Reserved																																	
	bit8	1: Master Frequency command controlled by communication interface																																	
	bit9	1: Master Frequency command controlled by analog signal input																																	
	bit10	1: Operation command controlled by communication interface																																	
	bit11	1: Parameter lock																																	
	bit12	1: Enable the digital keypad copy parameter function																																	
	bit15–13	Reserved																																	
	3	Freq. command (XXX.XXHz)	0	R	U16																														
	4	Output freq. (XXX.XXHz)	0	R	U16																														
	5	Output current (XX.XA)	0	R	U16																														
	6	DC bus voltage (XXX.XV)	0	R	U16																														
	7	Output voltage (XXX.XV)	0	R	U16																														
	8	The current segment run by the multi-segment speed command	0	R	U16																														
	9	Reserved	0	R	U16																														
	A	Display counter value (c)	0	R	U16																														
B	Display output power angle (XX.X°)	0	R	U16																															
C	Display output torque (XXX.X%)	0	R	U16																															
D	Display actual motor speed (rpm)	0	R	U16																															
E	Number of PG feedback pulses (0–65535)	0	R	U16																															
F	Number of PG2 pulse commands (0–65535)	0	R	U16																															
10	Power output (X.XXXkWh)	0	R	U16																															
17	Multi-function display (Pr.00-04)	0	R	U16																															
2022H	0	Reserved	0	R	U16																														
	1	Display output current	0	R	U16																														
	2	Display counter value	0	R	U16																														

Index	Sub	Definition	Default	R/W	Size	Note
	3	Display actual output frequency (XXX.XXHz)	0	R	U16	
	4	Display DC-BUS voltage (XXX.XV)	0	R	U16	
	5	Display output voltage (XXX.XV)	0	R	U16	
	6	Display output power angle (XX.X°)	0	R	U16	
	7	Display output power in kW	0	R	U16	
	8	Display actual motor speed (rpm)	0	R	U16	
	9	Display estimate output torque (XXX.X%)	0	R	U16	
	A	Display PG feedback	0	R	U16	
	B	Display PID feedback value after enabling PID function in % (To 2 decimal places)	0	R	U16	
	C	Display signal of AVI analog input terminal, 0–10V corresponds to 0–100% (To 2 decimal places)	0	R	U16	
	D	Display signal of ACI analog input terminal, 4–20mA/0–10V corresponds to 0–100% (To 2 decimal places)	0	R	U16	
	E	Display signal of AUI analog input terminal, -10V–10V corresponds to -100–100% (To 2 decimal places)	0	R	U16	
	F	Display the IGBT temperature of drive power module in °C	0	R	U16	
	10	Display the temperature of capacitance in °C	0	R	U16	
	11	The status of digital input (ON/OFF), refer to Pr.02-12	0	R	U16	
	12	The status of digital output (ON/OFF), refer to Pr.02-18	0	R	U16	
	13	Display the multi-step speed that is executing	0	R	U16	
	14	The corresponding CPU pin status of digital input	0	R	U16	
	15	The corresponding CPU pin status of digital output	0	R	U16	
	16	Number of actual motor revolutions (PG1 of PG card). Starts from 9 when the actual operation direction is changed, or the keypad display at stop is 0. Max. is 65535	0	R	U16	
	17	Pulse input frequency (PG2 of PG card)	0	R	U16	
	18	Pulse input position (PG card PG2), maximum setting is 65535.	0	R	U16	
	19	Position command tracing error	0	R	U16	
	1A	Display times of counter overload (0.00–100.00%)	0	R	U16	
	1B	Display GFF in %	0	R	U16	



Index	Sub	Definition	Default	R/W	Size	Note
	1C	Display DC BUS voltage ripples (Unit: V <sub>DC</sub> )	0	R	U16	
	1D	Display PLC register D1043 data	0	R	U16	
	1E	Display Pole of Permanent Magnet Motor	0	R	U16	
	1F	User page displays the value in physical measure	0	R	U16	
	20	Output Value of Pr.00-05	0	R	U16	
	21	Number of motor turns when drive operates	0	R	U16	
	22	Operation position of motor	0	R	U16	
	23	Fan speed of the drive	0	R	U16	
	24	Control mode of the drive 0: speed mode 1: torque mode	0	R	U16	
	25	Carrier frequency of the drive	0	R	U16	
	26	Reserved				
	27	Motor status				
	28	Output positive/ negative torque of motor drive calculation				
	29	Torque command				
	2A	kWh display				
	2B	PG2 pulse input low-word				
	2C	PG2 pulse input high-word				
	2D	Motor actual position low-word				
	2E	Motor actual position high-word				
	2F	PID reference target				
	30	PID bias value				
	31	PID output frequency				

## CANopen Remote IO mapping

Index	Sub	R/W	Definition
2026H	01h	R	Each bit corresponds to the different input terminals
	02h	R	Each bit corresponds to the different input terminals
	03h–40h	R	Reserved
	41h	RW	Each bit corresponds to the different output terminals
	42h–60h	R	Reserved
	61h	R	AVI proportional value (%)
	62h	R	ACI proportional value (%)
	63h	R	AUI proportional value (%)
	64h–6Ah	R	Reserved
	6Bh	R	Extension card AI10, 0.0–100.0% (EMC-A22A)
	6Ch	R	Extension card AI11, 0.0–100.0% (EMC-A22A)
	6Dh–A0h	R	Reserved
	A1h	RW	AFM1 output proportional value (%)
	A2h	RW	AFM2 output proportional value (%)
	A3h–AAh	RW	Reserved
	ABh	RW	Extension card AO10, 0.0–100.0% (EMC-A22A)
	ACh	RW	Extension card AO11, 0.0–100.0% (EMC-A22A)

Index 2026-01	bit0	bit1	bit2	bit3	bit4	bit5	bit6	bit7	bit8	bit9	bit10	bit11	bit12	bit13	bit14	bit15
1	FWD	REV	MI1	MI2	MI3	MI4	MI5	MI6	MI7	MI8						
2											MI10	MI11	MI12	MI13	MI14	MI15
3											MI10	MI11	MI12	MI13		

- 1: Control broad I/O (Standard)
- 2: Add external card, EMC-D611A
- 3: Add external card, EMC-D42A

Index 2026-41	bit0	bit1	bit2	bit3	bit4	bit5	bit6	bit7	bit8	bit9	bit10	bit11	bit12	bit13	bit14	bit15
1	RY1	RY2		MO1	MO2											
2						MO10	MO11									
3						RY10	RY11	RY12	RY13	RY14	RY15					

- 1: Control broad I/O (Standard)
- 2: Add external card, EMC-D42A
- 3: Add external card, EMC-R6AA

**Delta Standard Mode (New definition)**

Index	sub	R/W	Size	Descriptions			Speed Mode	Position Mode	Home Mode	Torque Mode	
				bit	Definition	Priority					
2060h	00h	R	U8						0: Stop Homing		
	01h	RW	U16	0	Ack	4	0: fcmd = 0 1: fcmd = Fset(Fpid)	Pulse 1: Position control	Pulse 1: Return to home		
				1	Dir	4	0: FWD run command 1: REV run command				
				2				0: Relative move 1: Absolute move			
				3	Halt	3	0: drive run till target speed is attained 1: drive stop by declaration setting			The torque target of internal decoding is set as 0, but the display of outside torque target will remain its outside setting.	
				4	Hold	4	0: drive run till target speed is attained 1: frequency stop at current frequency				
				5	JOG	4	0: JOG OFF Pulse 1: JOG RUN				
				6	Qstop	2	Quick Stop	Quick Stop	Quick Stop	Quick Stop	
				7	Power	1	0: Power OFF 1: Power ON	0: Power OFF 1: Power ON	0: Power OFF 1: Power ON	0: Power OFF 1: Power ON	
				8	Reserved						
				9	Ext Cmd2	4	0->1: Absolute position cleared	0->1: Absolute position cleared	0->1: Absolute position cleared	0->1: Absolute position cleared	
	10-14	Reserved									
	15	RST		Pulse 1: Fault code cleared	Pulse 1: Fault code cleared	Pulse 1: Fault code cleared	Pulse 1: Fault code cleared				
	02h	RW	U16		Mode Cmd		0: Speed mode 1: P2P position mode	3: Home mode	2: Torque mode		
	03h	RW	U16				Speed command (unsigned decimal)				
04h	RW	U16									
05h	RW	S32					Position command				

Index	sub	R/W	Size	Descriptions			Speed Mode	Position Mode	Home Mode	Torque Mode	
				bit	Definition	Priority					
	06h	RW									
	07h	RW	U16							Torque command (signed decimal)	
	08h	RW	U16							Speed limit (unsigned decimal)	
2061h	01h	R	U16	0	Arrive		Frequency attained	Position attained	Homing complete		Torque attained
				1	Dir		0: Motor FWD run 1: Motor REV run	0: Motor FWD run 1: Motor REV run	0: Motor FWD run 1: Motor REV run	0: Motor FWD run 1: Motor REV run	0: Motor FWD run 1: Motor REV run
				2	Warn		Warning	Warning	Warning	Warning	Warning
				3	Error		Error detected	Error detected	Error detected	Error detected	Error detected
				4							
				5	JOG		JOG	JOG	JOG	JOG	JOG
				6	Qstop		Quick stop	Quick stop	Quick stop	Quick stop	Quick stop
				7	Power On		Switch ON	Switch ON	Switch ON	Switch ON	Switch ON
	15-8										
	02h	R									
	03h	R	U16				Actual output frequency	Actual output frequency	Actual output frequency	Actual output frequency	
	04h	R									
	05h	R	S32				Actual position (absolute)	Actual position (absolute)	Actual position (absolute)	Actual position (absolute)	
06h	R										
07h	R	S16				Actual torque	Actual torque	Actual torque	Actual torque		

**DS402 Standard**

Index	Sub	Definition	Default	R/W	Size	Unit	PDO Map	Mode	Note
6007h	0	Abort connection option code	2	RW	S16		Yes		0: No action 2: Disable Voltage 3: Quick stop
603Fh	0	Error code	0	R0	U16		Yes		
6040h	0	Control word	0	RW	U16		Yes		
6041h	0	Status word	0	R0	U16		Yes		
6042h	0	vl target velocity	0	RW	S16	rpm	Yes	vl	
6043h	0	vl velocity demand	0	RO	S16	rpm	Yes	vl	
6044h	0	vl control effort	0	RO	S16	rpm	Yes	vl	
604Fh	0	vl ramp function time	10000	RW	U32	1ms	Yes	vl	Unit must be 100ms, and check if the setting is 0.
6050h	0	vl slow down time	10000	RW	U32	1ms	Yes	vl	
6051h	0	vl quick stop time	1000	RW	U32	1ms	Yes	vl	
605Ah	0	Quick stop option code	2	RW	S16		No		0: Disable drive function 1: Slow down on slow down ramp 2: Slow down on quick stop ramp 5: Slow down on slow down ramp and stay in QUICK STOP 6: Slow down on quick stop ramp and stay in QUICK STOP
605Ch	0	Disable operation option code	1	RW	S16		No		0: Disable drive function 1: Slow down with slow down ramp; disable the drive function
6060h	0	Mode of operation	2	RW	S8		Yes		1: Profile Position Mode 2: Velocity Mode 4: Torque Profile Mode

Index	Sub	Definition	Default	R/W	Size	Unit	PDO Map	Mode	Note
									6: Homing Mode
6061h	0	Mode of operation display	2	RO	S8		Yes		Same as above
6064h	0	pp Position actual value	0	RO	S32		Yes	pp	
6071h	0	tq Target torque	0	RW	S16	0.1%	Yes	tq	Valid unit: 1%
6072h	0	tq Max torque	150	RW	U16	0.1%	No	tq	Valid unit: 1%
6075h	0	tq Motor rated current	0	RO	U32	mA	No	tq	
6077h	0	tq torque actual value	0	RO	S16	0.1%	Yes	tq	
6078h	0	tq current actual value	0	RO	S16	0.1%	Yes	tq	
6079h	0	tq DC link circuit voltage	0	RO	U32	mV	Yes	tq	
607Ah	0	pp Target position	0	RW	S32	1	Yes	pp	

## 15-5 CANopen Fault Code

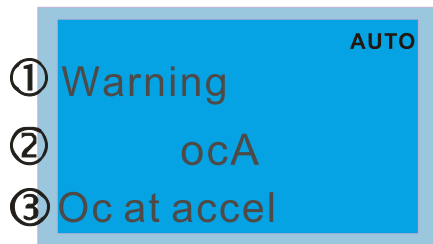

① Warning

② ocA

③ Oc at accel

① Display error signal



② Abbreviate error code

③ Display error description

\*: Refer to setting value of Pr.06-17–Pr. 06-22

ID No.*	Display	Fault code	Description	CANopen fault register (bit 0–7)	CANopen fault code
1	Fault ocA Oc at accel	0001H	Over-current during acceleration	1	2213 H
2	Fault ocd Oc at decel	0002H	Over-current during deceleration	1	2213 H
3	Fault ocn Oc at normal SPD	0003H	Over-current during steady operation	1	2214H
4	Fault GFF Ground fault	0004H	Ground fault. When one of the output terminals is grounded, the short circuit current is more than 50% of AC motor drive rated current. NOTE: The short circuit protection is provided for the AC motor drive protection, not to protect the user.	1	2240H
5	Fault occ Short Circuit	0005H	Short-circuit is detected between upper bridge and lower bridge of the IGBT module.	1	2250H
6	Fault ocS Oc at stop	0006H	Over-current at stop. Hardware failure in current detection	1	2214H
7	Fault ovA Ov at accel	0007H	Over-current during acceleration. Hardware failure in current detection	2	3210H
8	Fault ovd Ov at decel	0008H	Over-current during deceleration. Hardware failure in current detection.	2	3210H

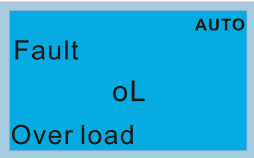
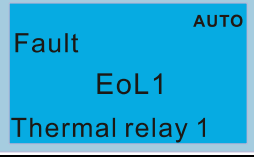
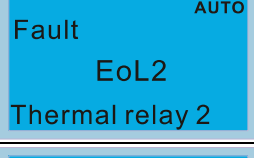
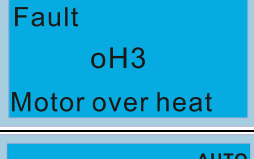
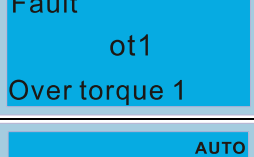
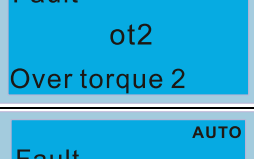
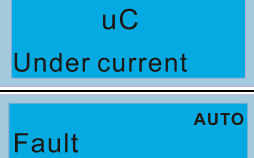
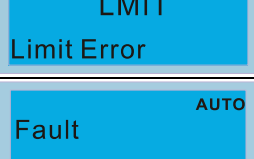
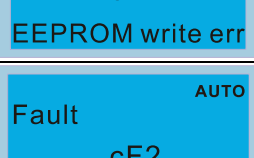
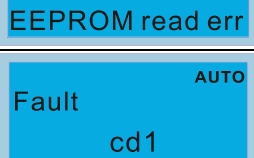
ID No.*	Display	Fault code	Description	CANopen fault register (bit 0–7)	CANopen fault code
9	Fault Ovn Ov at normal SPD	0009H	DC BUS over-voltage at constant speed	2	3210H
10	Fault ovS Ov at stop	000AH	Over-voltage at stop. Hardware failure in voltage detection	2	3210H
11	Fault LvA Lv at accel	000BH	DCBUS voltage is less than Pr.06-00 during acceleration.	2	3220H
12	Fault Lvd Lv at decel	000CH	DCBUS voltage is less than Pr.06-00 during deceleration.	2	3220H
13	Fault Lvn Lv at normal SPD	000DH	DCBUS voltage is less than Pr.06-00 at constant speed.	2	3220H
14	Fault LvS Lv at stop	000EH	DCBUS voltage is less than Pr.06-00 at stop	2	3220H
15	Fault OrP Phase lacked	000FH	Phase Loss Protection	2	3130H
16	Fault oH1 IGBT over heat	0010H	IGBT is overheated above the protection level. 1–15HP: 90°C 20–100HP: 100°C	3	4310H
17	Fault oH2 Heat Sink oH	0011H	Heat sink overheat Heat sink temperature exceeds 90°C	3	4310H
18	Fault tH1o Thermo 1 open	0012H	IGBT over-heating protection error	3	FF00H
19	Fault tH2o Thermo 2 open	0013H	Temperature detection circuit error (capacity module) CAP NTC	3	FF01H

ID No.*	Display	Fault code	Description	CANopen fault register (bit 0–7)	CANopen fault code
21	 Fault oL Over load	0015H	Overload; the AC motor drive detects excessive drive output current. NOTE: The AC motor drive can withstand up to 150% of the rated current for a maximum of 60 seconds.	1	2310H
22	 Fault EoL1 Thermal relay 1	0016H	Electronic thermal relay 1 protection	1	2310H
23	 Fault EoL2 Thermal relay 2	0017H	Electronic thermal relay 2 protection	1	2310H
24	 Fault oH3 Motor over heat	0018H	Motor overheating: the AC motor drive internal temperature exceeds the setting for Pr. 06-30 (PTC level).	3	FF20H
26	 Fault ot1 Over torque 1	001AH	When the output current exceeds the over-torque detection level (Pr. 06-07 or Pr. 06-10) and exceeds Pr. 06-08 or Pr. 06-11; when Pr. 06-06 or Pr. 06-09 is set as 2 or 4, the keypad displays these two fault codes.	3	8311H
27	 Fault ot2 Over torque 2	001BH		3	8311H
28	 Fault uC Under current	001CH	Low current detection	1	8321H
29	 Fault LMIT Limit Error	001DH	Home limit error	1	7320H
30	 Fault cF1 EEPROM write err	001EH	Cannot program internal EEPROM	5	5530H
31	 Fault cF2 EEPROM read err	001FH	Cannot read internal EEPROM	5	5530H
33	 Fault cd1 las sensor err	0021H	U-phase current error	1	FF04H

ID No.*	Display	Fault code	Description	CANopen fault register (bit 0–7)	CANopen fault code
34	Fault cd2 lbs sensor err AUTO	0022H	V-phase current error	1	FF05H
35	Fault cd3 lcs sensor err AUTO	0023H	W-phase current error	1	FF06H
36	Fault Hd0 cc HW error AUTO	0024H	cc (current clamp) hardware error	5	FF07H
37	Fault Hd1 Oc HW error AUTO	0025H	oc hardware error	5	FF08H
38	Fault Hd2 Ov HW error AUTO	0026H	ov hardware error	5	FF09H
39	Fault Hd3 occ HW error AUTO	0027H	GFF hardware error	5	FF0AH
40	Fault AUE Auto tuning error AUTO	0028H	Motor parameters auto-tuning error	1	FF21H
41	Fault AFE PID Fbk error AUTO	0029H	PID loss (ACI)	7	FF22H
42	Fault PGF1 PG Fbk error AUTO	002AH	PG feedback error	7	7301H
43	Fault PGF2 PG Fbk loss AUTO	002BH	PG feedback loss	7	7301H
44	Fault PGF3 PG Fbk over SPD AUTO	002CH	PG feedback stall	7	7301H



ID No.*	Display	Fault code	Description	CANopen fault register (bit 0–7)	CANopen fault code
45	Fault PGF4 PG Fbk deviate	002DH	PG slip error	7	7301H
48	Fault ACE ACI loss	0030H	ACI loss (ACE)	1	FF25H
49	Fault EF External fault	0031H	External Fault; when the multi-function input terminal (EF) is active, the AC motor drive stops output.	5	9000H
50	Fault EF1 Emergency stop	0032H	Emergency stop; when the multi-function input terminals MI1 to MI6 are active, the AC motor drive stops output.	5	9000H
51	Fault bb Base block	0033H	External Base Block; when the multi-function input terminal (B.B.) is active, the AC motor drive stops output.	5	9000H
52	Fault Pcod Password error	0034H	Keypad is locked after you enter the wrong password three times.	5	FF26H
54	Fault CE1 PC err command	0036H	Modbus function code error (illegal function code)	4	7500H
55	Fault CE2 PC err address	0037H	Modbus data address error [illegal data address (00 H–254 H)]	4	7500H
56	Fault CE3 PC err data	0038H	Modbus data error (illegal data value)	4	7500H
57	Fault CE4 PC slave fault	0039H	Modbus communication error (data is written to read-only address)	4	7500H

ID No.*	Display	Fault code	Description	CANopen fault register (bit 0–7)	CANopen fault code
58	Fault CE10 PC time out	003AH	Modbus transmission time-out.	5	7500H
60	Fault bF Braking fault	003CH	Brake resistor error	4	7110H
61	Fault ydc Y-delta connect	003DH	Y-connection / $\Delta$ -connection switch error	2	3330H
62	Fault dEb Dec. Energy back	003EH	Energy regeneration when decelerating	2	FF27H
63	Fault oSL Over slip error	003FH	Motor slip exceeds Pr. 05-26 and Pr. 05-27 setting	7	FF28H
64	Fault ryF MC Fault	0040H	Electric valve switch error	5	7110H
65	Fault PGF5 PG HW Error	0041H	PG Card Error	5	FF29H
68	Fault SdRv SpdFbk Dir Rev	0044H	Reverse direction of the speed feedback	7	8400H
69	Fault SdOr SpdFbk over SPD	0045H	Over speed rotation feedback	7	8400H
70	Fault SdDe SpdFbk deviate	0046H	Large deviation of speed feedback	7	8400H
72	Fault STL1 STO Loss 1	0048H	STO1–SCM1 internal loop detection error	5	5441H

ID No.*	Display	Fault code	Description	CANopen fault register (bit 0–7)	CANopen fault code
73	Fault S1 S1-emergency stop	0049H	Emergency stop for external safety	5	FF2AH
75	Fault Brk EXT-Brake Error	004BH	External brake error	5	7110H
76	Fault STO STO	004CH	Safe Torque Off function active	5	5440H
77	Fault STL2 STO Loss 2	004DH	STO2–SCM2 internal loop detection error	5	5442H
78	Fault STL3 STO Loss 3	004EH	STO1–SCM1 and STO2–SCM2 internal loop detection error	5	5443H
82	Fault OPHL U phase lacked	0052H	Output phase loss 1 (Phase U)	2	2331H
83	Fault OPHL V phase lacked	0053H	Output phase loss 2 (Phase V)	2	2332H
84	Fault OPHL W phase lacked	0054H	Output phase loss 3 (Phase W)	2	2333H
85	Fault AboF PG ABZ Line off	0055H	PG ABZ line off	5	7301H
86	Fault UvoF PG UVW Line off	0056H	PG UVW line off	5	7301H
89	Fault RoPd Rotor Pos. Error	0059H	Rotor position detection error	7	FF30H

ID No.*	Display	Fault code	Description	CANopen fault register (bit 0–7)	CANopen fault code
90	Fault Fstp Force Stop	005AH	Force to stop	7	FF2EH
101	Fault CGdE Guarding T-out	0065H	CANopen guarding error	4	8130H
102	Fault CHbE Heartbeat T-out	0066H	CANopen heartbeat error	4	8130H
104	Fault CbFE Can bus off	0068H	CANopen bus off error	4	8140H
105	Fault CIdE Can bus Index Err	0069H	CANopen index error	4	8100H
106	Fault CAde Can bus Add. Err	006AH	CANopen station address error	4	8100H
107	Fault CFrE Can bus off	006BH	CANopen memory error	4	8100H
111	Fault ictE InrCom Time Out	006FH	InrCOM internal communication special error code	4	7500H
112	Fault SfLK PMLess Shaft Lock	0070H	PMLess shaft lock	7	FF31H

### 15-6 CANopen LED Function

There are two CANopen flash signs: RUN and ERR.

RUN LED:

LED status	Condition	CANopen State
OFF	OFF	Initial
Blinking		Pre-Operation
Single flash		Stopped
ON	ON	Operation

ERR LED:

LED status	Condition / Status
OFF	No Error
Single flash	<p>One Message failure</p>
Double flash	<p>Guarding failure or heartbeat failure</p>
Triple flash	<p>SYNC failure</p>
ON	Bus off

# ***Chapter 16 PLC Function Applications***

---

- 16-1 PLC Summary
- 16-2 Notes before PLC use
- 16-3 Turn on
- 16-4 Basic principles of PLC ladder diagrams
- 16-5 Various PLC device functions
- 16-6 Introduction to the Command Window
- 16-7 Error display and handling
- 16-8 CANopen Master control applications
- 16-9 Explanation of various PLC mode controls (speed, torque, homing, and position)
- 16-10 Internal communications main node control
- 16-11 Count function using MI8
- 16-12 Modbus remote IO control applications (use MODRW)
- 16-13 Calendar Function

## 16-1 PLC Summary

### 16-1-1 Introduction

The commands provided by the C2000's built-in PLC functions, including the ladder diagram editing tool WPLSoft, as well as the usage of basic commands and applications commands, chiefly retain the operating methods of Delta's PLC DVP series.

### 16-1-2 WPLSoft ladder diagram editing tool

WPLSoft is Delta's program editing software for the DVP and C2000 programmable controllers in the Windows operating system environment. Apart from general PLC program design general Windows editing functions (such as cut, paste, copy, multiple windows, etc.), WPLSoft also provides many Chinese/ English annotation editing and other convenience functions (such as registry editing, settings, file reading, saving, and contact graphic monitoring and settings, etc.).

The following basic requirements that need to install WPLSoft editing software:

Item	System requirements
Operating system	Windows 95/98/2000/NT/ME/XP
CPU	At least Pentium 90
Memory	At least 16MB (we recommend at least 32MB)
Hard drive	Hard drive capacity: at least 100MB free space One optical drive (for use in installing this software)
Display	Resolution: 640×480, at least 16 colors; it is recommended that the screen area be set at 800×600 pixels
Mouse	Ordinary mouse or Windows-compatible device
Printer	Printer with a Windows driver program
RS-485 port	Must have at least an RS-485 port to link to the PLC
Suitable PLC models	Delta's full DVP-PLC series, VFD-C2000 series

## 16-2 Notes before PLC use

1. The PLC has a preset communications format of 7, N, 2, 9600, with node 2; the PLC node can be changed in Pr. 09-35, but this address may not be the same as the drive's address setting of Pr. 09-00.
2. The C2000 provides 2 communications serial ports that can be used to download PLC programs (see figure below). Channel 1 has a fixed communications format of 19200, 8, N, 2 RTU.

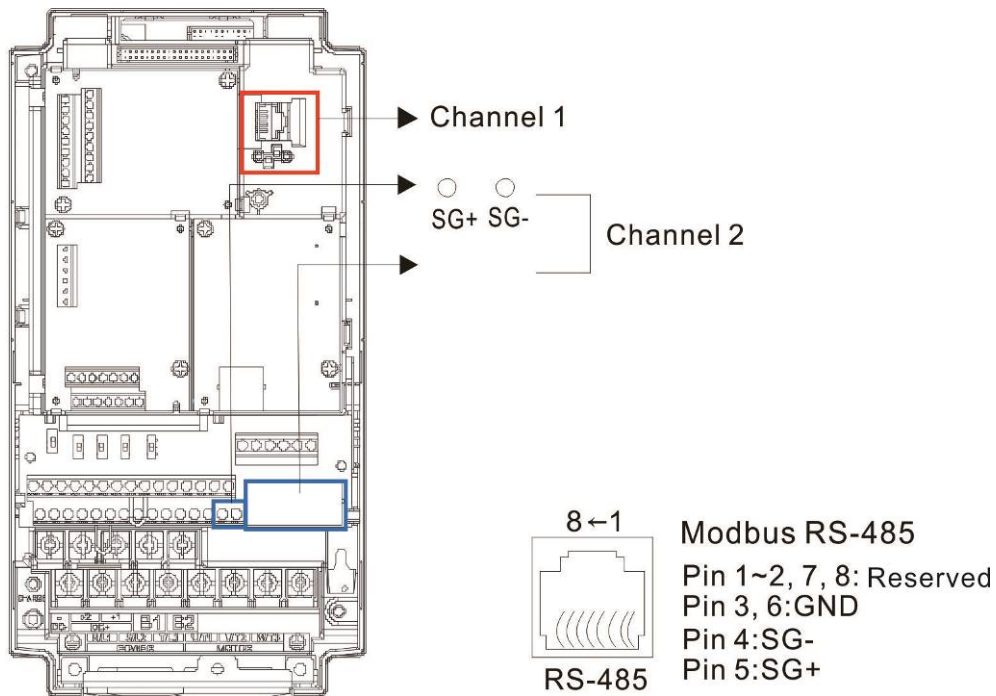

3. The client can simultaneously access data from the converter and internal PLC, which is performed through identification of the node. For instance, if the converter node is 1 and the internal PLC node is 2, then the client command will be  
 01 (node) 03 (read) 0400 (address) 0001 (1 data item), indicating that it must read the data in converter Pr. 04-00  
 02 (node) 03 (read) 0400 (address) 0001 (1 data item), indicating that it must read the data in internal PLC X0
4. The PLC program will be disabled when uploading/ downloading programs.
5. Please note when using WPR commands to write in parameters, values may be modified up to a maximum of  $10^9$  times, otherwise a memory write error will occur. The calculation of modifications is based on whether the entered value has been changed. If the entered value is left unchanged, the modifications will not increase afterwards. But if the entered value is different from before, the number of modifications will increase by one.
6. When Pr. 00-04 is set as 28, the displayed value will be the value of PLC register D1043 (see figure below):



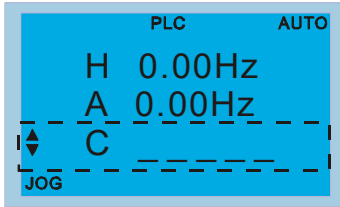

Digital Keypad KPC-CC01

Can display 0–65535

7. In the PLC Run and PLC Stop mode, the content 9 and 10 of Pr. 00-02 cannot be set and cannot be reset to the default value.
8. The PLC can be reset to the default value when Pr. 00-02 is set as 6.
9. The corresponding MI function will be disabled when the PLC writes to input contact X.
10. When the PLC controls converter operation, control commands will be entirely controlled by the PLC and will not be affected by the setting of Pr. 00-21.
11. When the PLC controls converter frequency commands (FREQ commands), frequency commands will be entirely controlled by the PLC, and will not be affected by the setting of Pr. 00-20 or the Hand ON/OFF configuration.
12. When the PLC controls converter frequency (TORQ commands), torque commands will be entirely controlled by the PLC, and will not be affected by the setting of Pr. 11-33 or the Hand ON/OFF configuration.
13. When the PLC controls converter frequency (POS commands), position commands will be entirely controlled by the PLC, and will not be affected by the setting of Pr. 11-40 or the Hand ON/OFF configuration.
14. When the PLC controls converter operation, if the keypad Stop setting is valid, this will trigger an FStP error and cause stoppage.

## 16-3 Turn on

### 16-3-1 Connect to PC

Start operation of PLC functions in accordance with the following four steps

1. After pressing the Menu key and selecting **4: PLC** on the KPC-CC01 digital keypad, press the Enter key (see figure below).

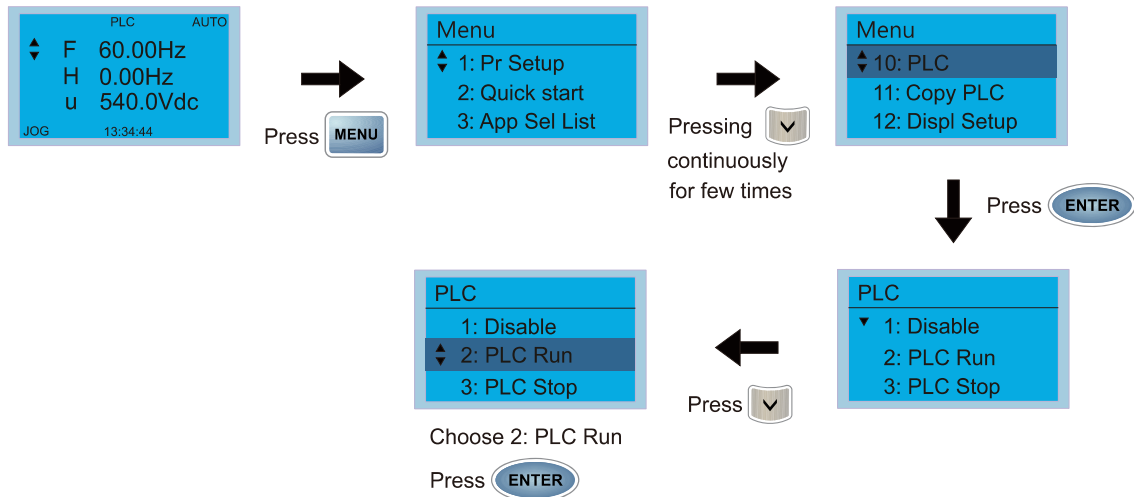

2. Wiring: Connect the drive's RJ45 communications interface to a PC via the RS-485.

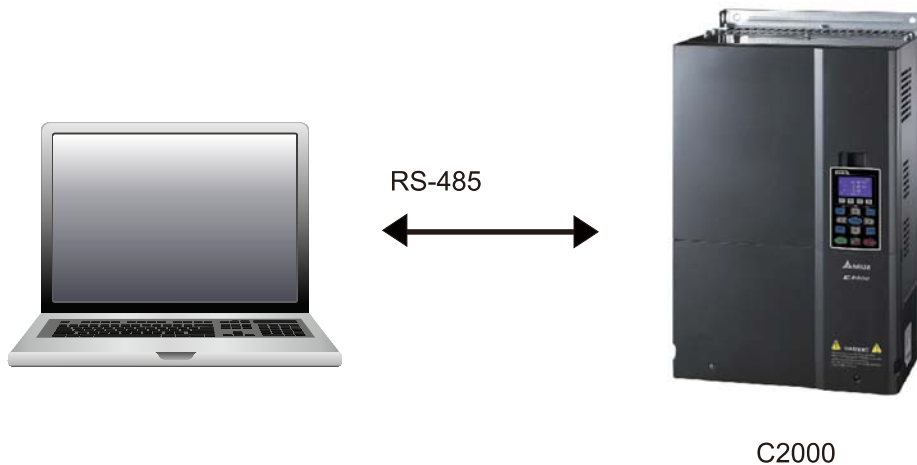

3. PLC function usage

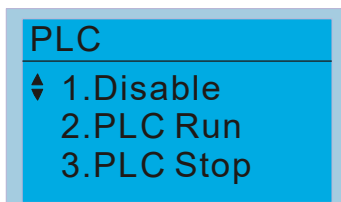

- PLC functions are as shown in the figure on the left; select item 2 and implement PLC functions.

- 1: No function (Disable)
- 2: Enable PLC (PLC Run)
- 3: Stop PLC functions (PLC Stop)

- When the external multifunctional input terminals (MI1–MI8) are in PLC Mode select bit0 (51) or PLC Mode select bit1 (52), and the terminal contact is closed or opened, it will compulsorily switch to the PLC mode, and keypad switching will be ineffective. Corresponding actions are as follows:

PLC mode	PLC Mode select bit1(52)	PLC Mode select bit0 (51)
Using KPC-CC01		
Disable	OFF	OFF
PLC Run	OFF	ON
PLC Stop	ON	OFF
Maintain previous state	ON	ON

 **NOTE**

- When input/ output terminals (FWD REV MI1–MI8, MI10–15, Relay1, Relay2, RY10–RY15, MO1–MO2, and MO10–MO11) are included in the PLC program, these input/ output terminals will only be used by the PLC. As an example, when the PLC program controls Y0 during PLC operation (PLC1 or PLC2), the corresponding output terminal relay (RA/RB/RC) will operate in accordance with the program. At this time, the multifunctional input/ output terminal setting will be ineffective. Because these terminal functions are already being used by the PLC, the DI/ DO/ AO in use by the PLC can be determined by looking at Pr. 02-52, Pr. 02-53, and Pr. 03-30.
- When the PLC's procedures use special register D1040, the corresponding AO contact AFM1 will be occupied, and AFM2 corresponding to special register D1045 will have the same situation.
- Pr. 03-30 monitors the state of action of the PLC function analog output terminal; bit0 corresponds to the AFM1 action state, and bit1 corresponds to the AFM2 action state.

### 16-3-2 I/O device explanation

Input devices:

Serial No.	X0	X1	X2	X3	X4	X5	X6	X7	X10	X11	X12	X13	X14	X15	X16	X17
1	FWD	REV	MI1	MI2	MI3	MI4	MI5	MI6	MI7	MI8						
2											MI10	MI11	MI12	MI13	MI14	MI15
3											MI10	MI11	MI12	MI13		

1: Control I/O |

2: Expansion card: EMC-D611A (D1022=4)

3: Expansion card: EMC-D42A (D1022=5)

Output devices:

Serial No.	Y0	Y1	Y2	Y3	Y4	Y5	Y6	Y7	Y10	Y11	Y12	Y13	Y14	Y15	Y16	Y17
1	RY1	RY2		MO1	MO2											
2						MO10	MO11									
3						RY10	RY11	RY12	RY13	RY14	RY15					

1: Control I/O |

2: Expansion card: EMC-D42A (D1022=5)

3: Expansion card: EMC-R6AA (D1022=6)

**RY1 / RY2 / RY3**

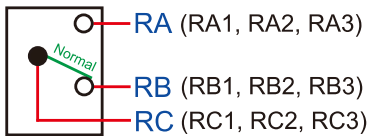

**RY10 / RY11 / RY12 / RY13 / RY14 / RY15**

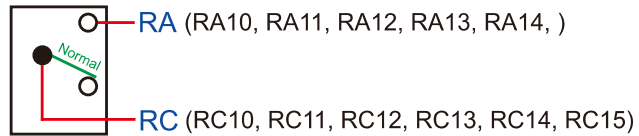

### 16-3-3 Installation WPLSoft

Download and install WPLSoft editing software in Delta's website:



After completing installation, the WPLSoft program will be installed in the designated subfolder "C:\Program Files\Delta Industrial Automation\WPLSoft x.xx".

### 16-3-4 Program writing

Step 1: Click on the WPLSoft icon to start the editing software. (See figure 16-1)



Figure 16-1 (Left: WPLSoft icon; Right: Start WPLSoft)

Step 2: The WPLSoft editing window appears (see figure 16-2 below). When running WPLSoft for the first time, before "New file" has been used, only the "File (F)," "Communications (C)," View (V)," "Options (O)," and "Help (H)" columns will appear on the function toolbar.

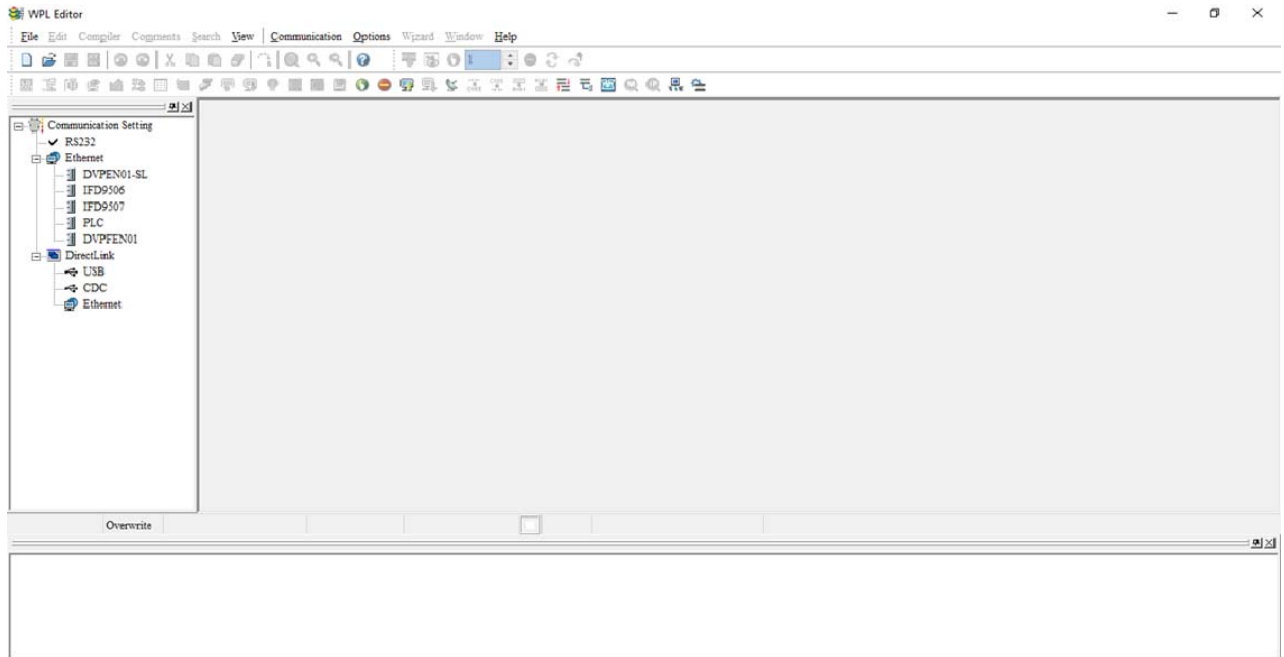

Figure 16-2

**NOTE** After running WPLSoft for the second time, the last file edited will open and be displayed in the editing window. The following figure 16-3 provides an explanation of the WPLSoft editing software window:

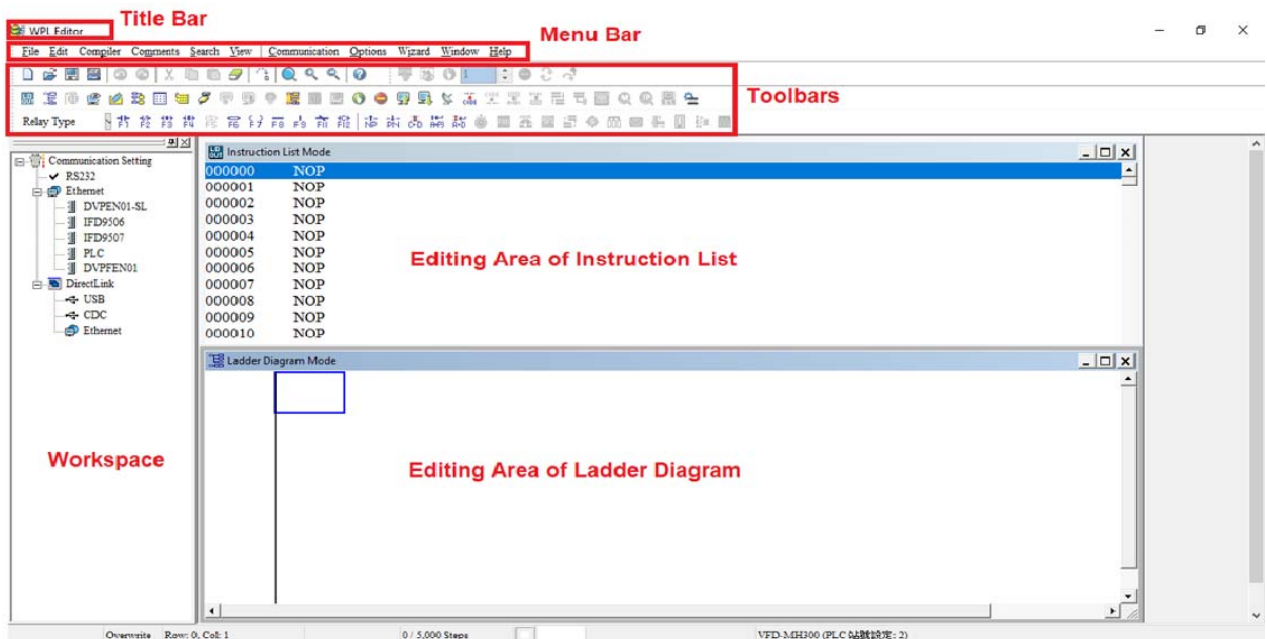



Figure 16-3

Step 3: Click on the  icon on the toolbar: opens new file (Ctrl+N), see figure 16-4 below

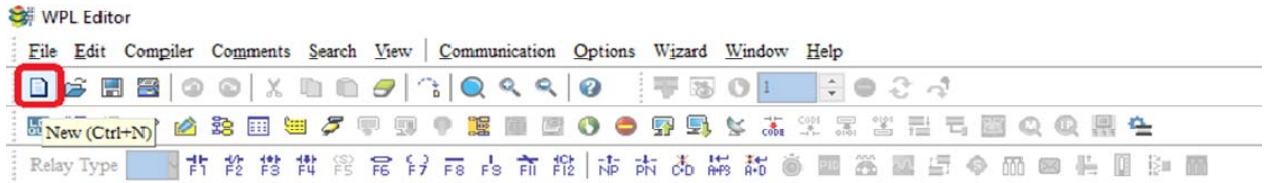



Figure 16-4

 **NOTE** You can also find “New file (N) (Ctrl+N)” in the "File (F)", as shown in figure 16-5 below.

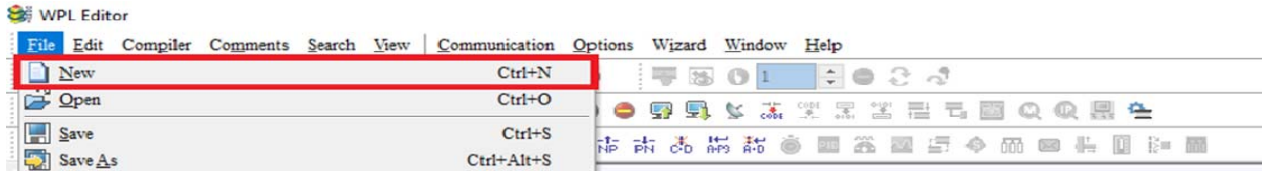

Figure 16-5

Step 4: The "Device settings" window will appear after clicking, see figure 16-6 below. You can now enter the project title and filename, and select the device and communication settings to be used.

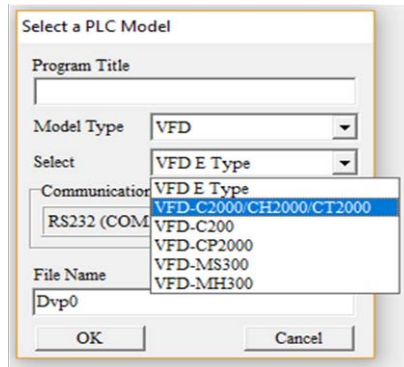

Figure 16-6

Communications settings: Perform settings in accordance with the desired communications method. See figure 16-7 below.

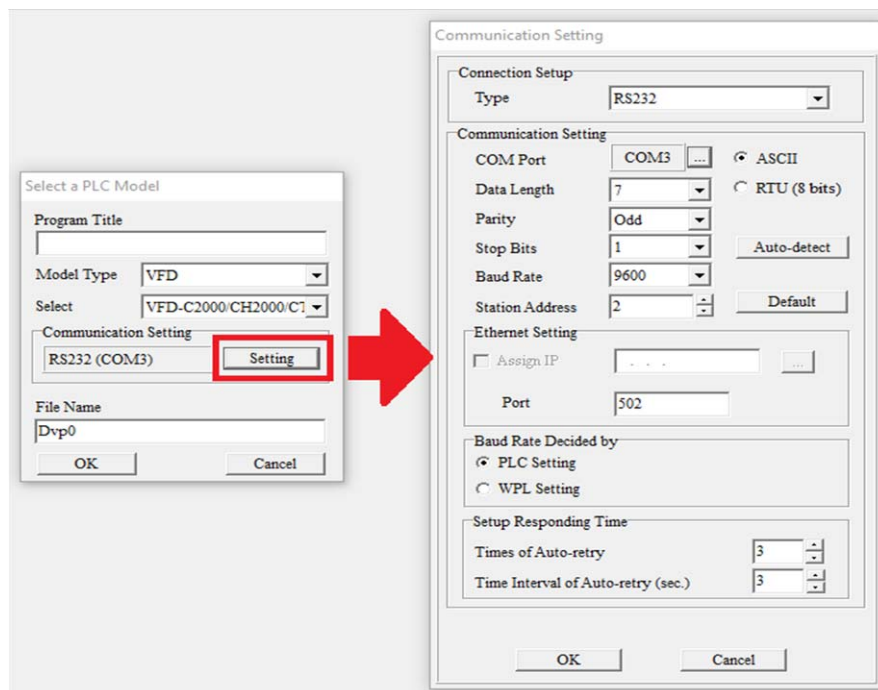

Figure 16-7

Step 5: Press Confirm after completing settings and begin program editing. There are two program editing methods; you can choose whether to perform editing in the command mode or the ladder diagram mode (see figure 16-8 below).

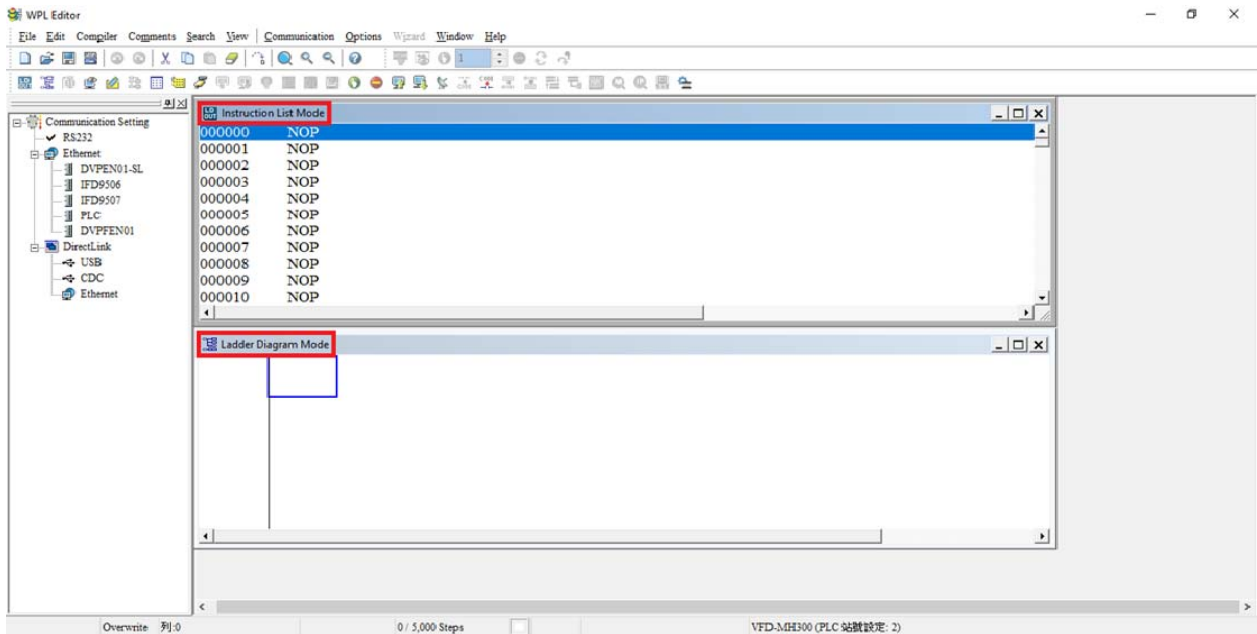

Figure 16-8

**NOTE** In ladder diagram mode, you can perform program editing using the buttons on the function icon row (see figure 16-9 below).

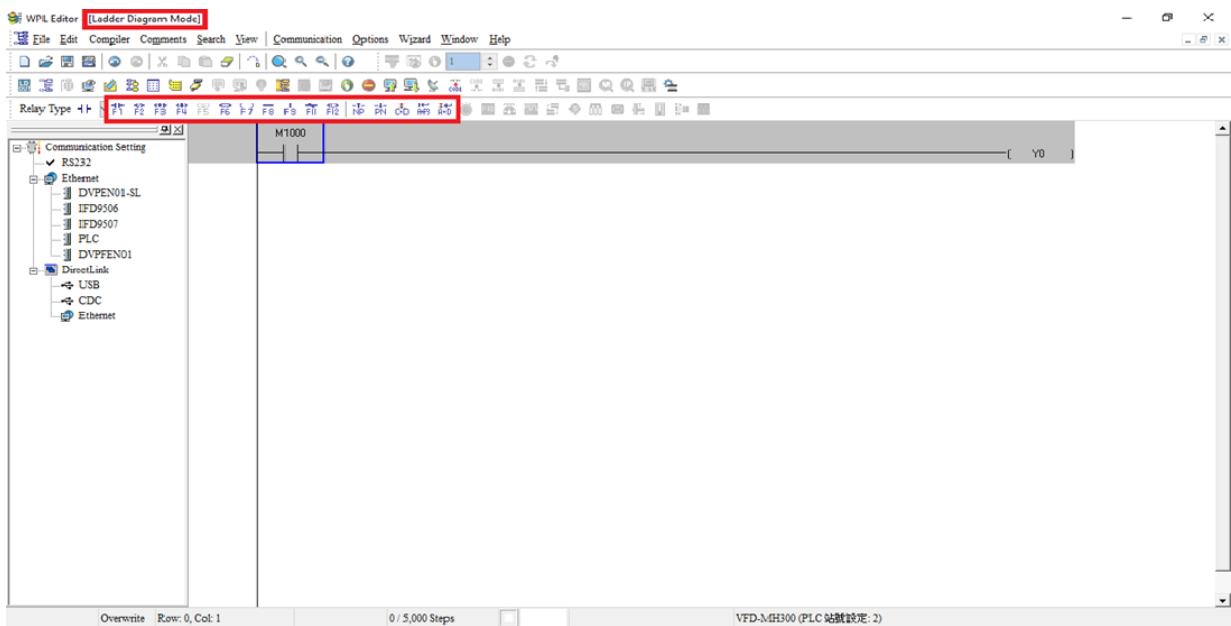

Figure 16-9

## Basic Operation-Example

Input the ladder diagram as the figure below. The following steps can be operated through the mouse or function key (F1–F12) on the keyboard.

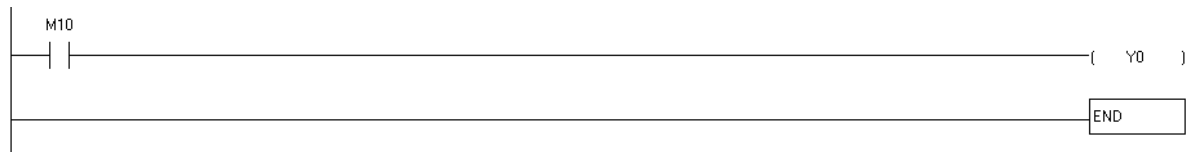

Figure 16-10

Step 1: The following screen will appear after a new file is established:

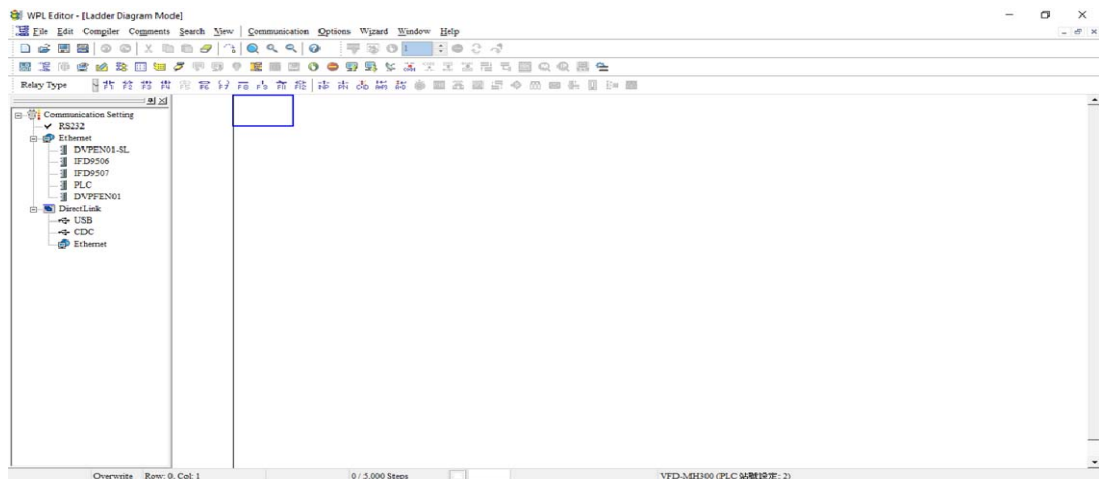



Figure 16-11

Step 2: Click on the always-open switch icon  or press the function key F1. After the name of the input device and the comment dialog box have appeared, the device name (such as "M"), device number (such as "10"), and input comments (such as "auxiliary contact") can be selected; press the OK button when finished (see figure 16-12 and 16-13 below).

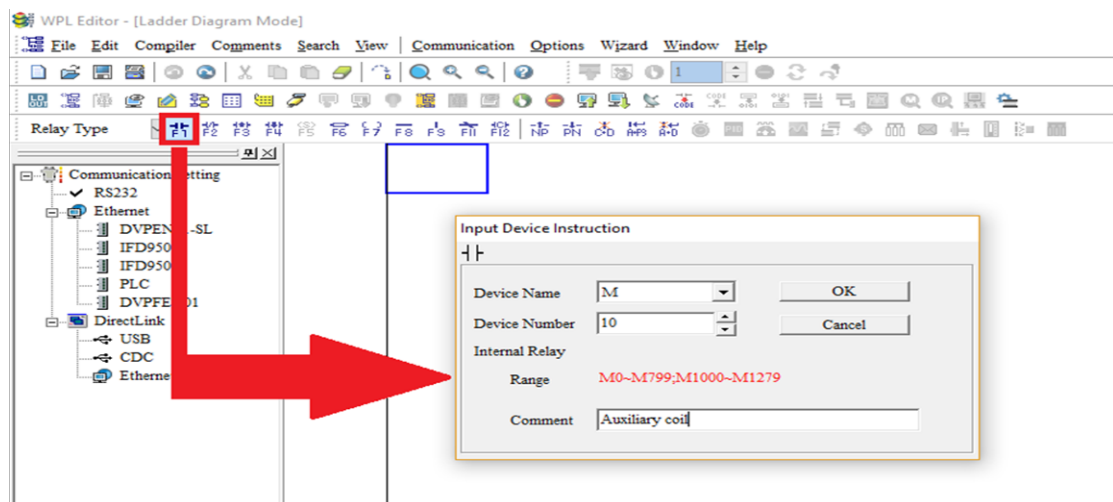

Figure 16-12



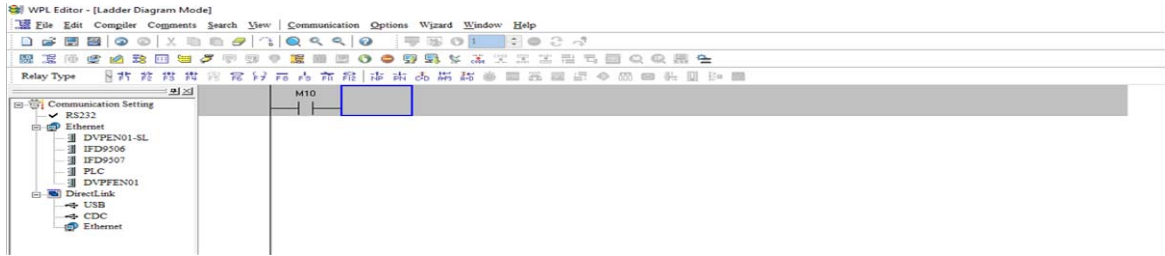



Figure 16-13

Step 3: Click on the output coil icon  or press function key F7. After the name of the input device and the comment dialog box have appeared, the device name (such as "Y"), device number (such as "0"), and input comments (such as "output coil") can be selected; press the OK button when finished (see figure 16-14 and 16-15 below).

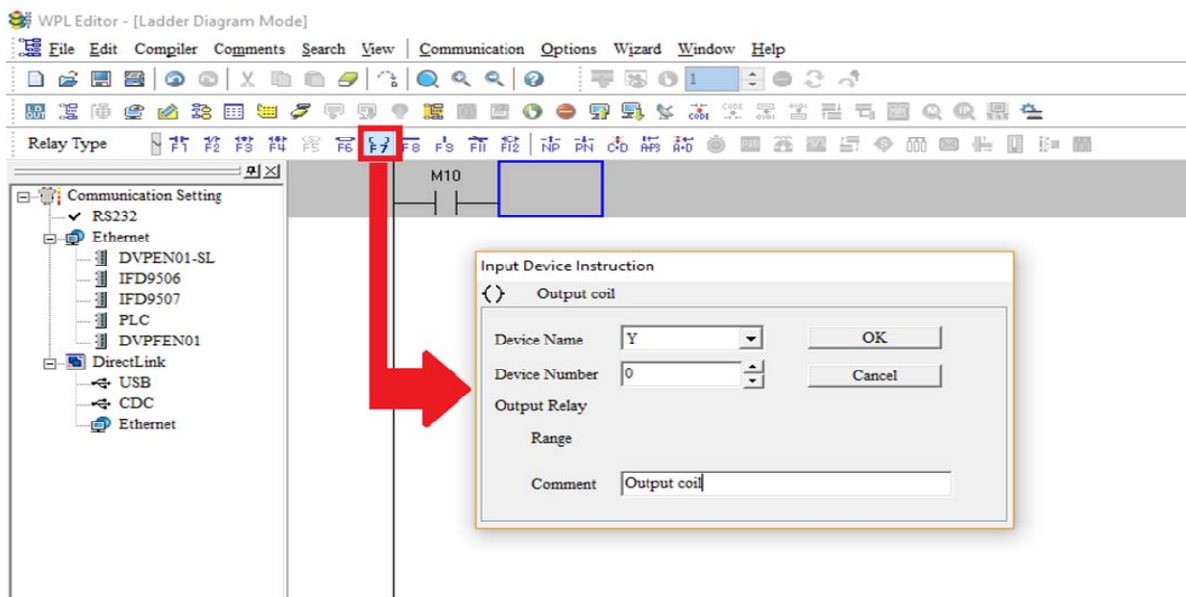

Figure 16-14

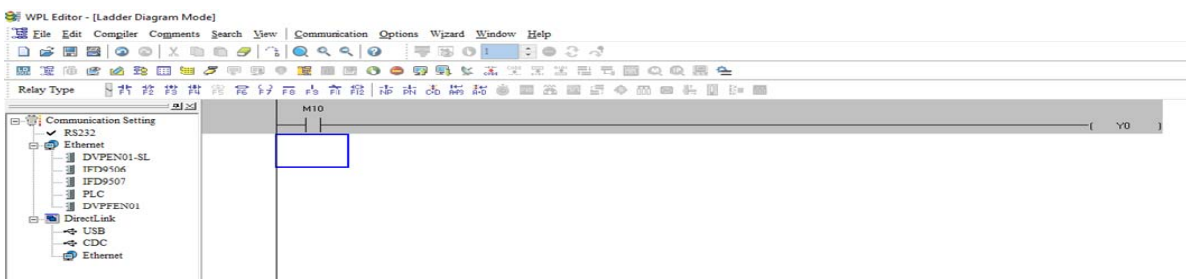

Figure 16-15

Step 4: Press “ENTER” button, when the “Input Instructions” window appears, key in “END” in the field and press the OK button (see figure 16-16 and 16-17 below).

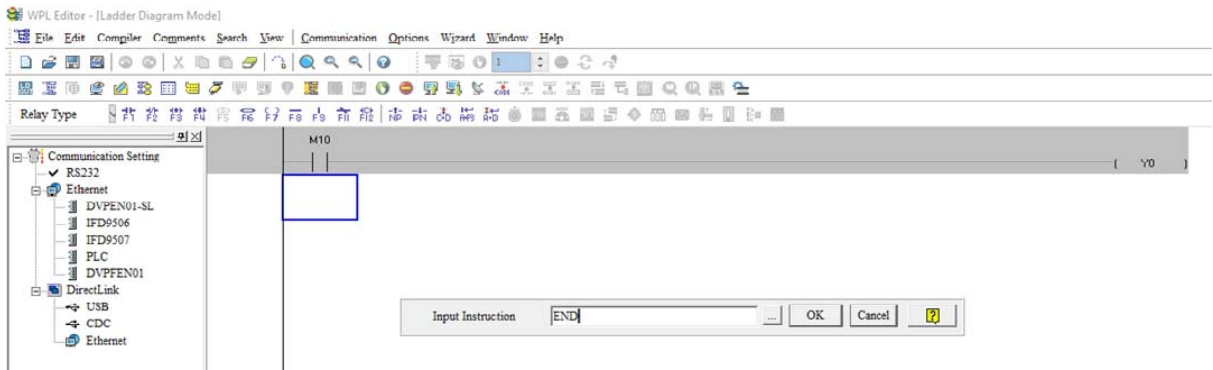

Figure 16-16

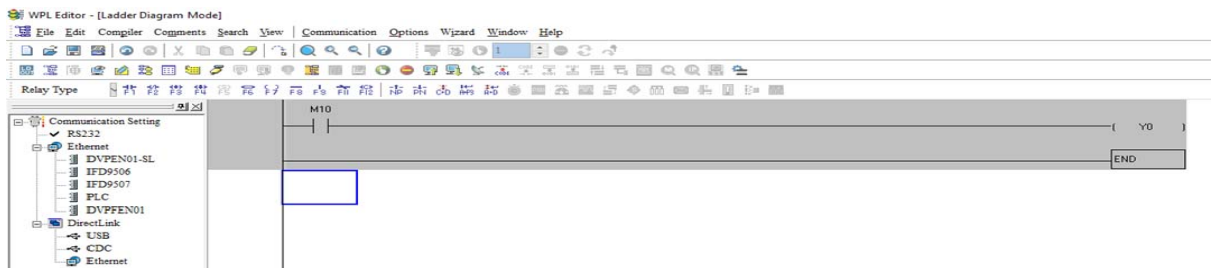



Figure 16-17

Step 5: Click on the  “Ladder diagram => Code” icon, which will compile the edited ladder diagram as a command program. After compiling, the number of steps will appear on the left side of the busbar (see figure 16-18 below).

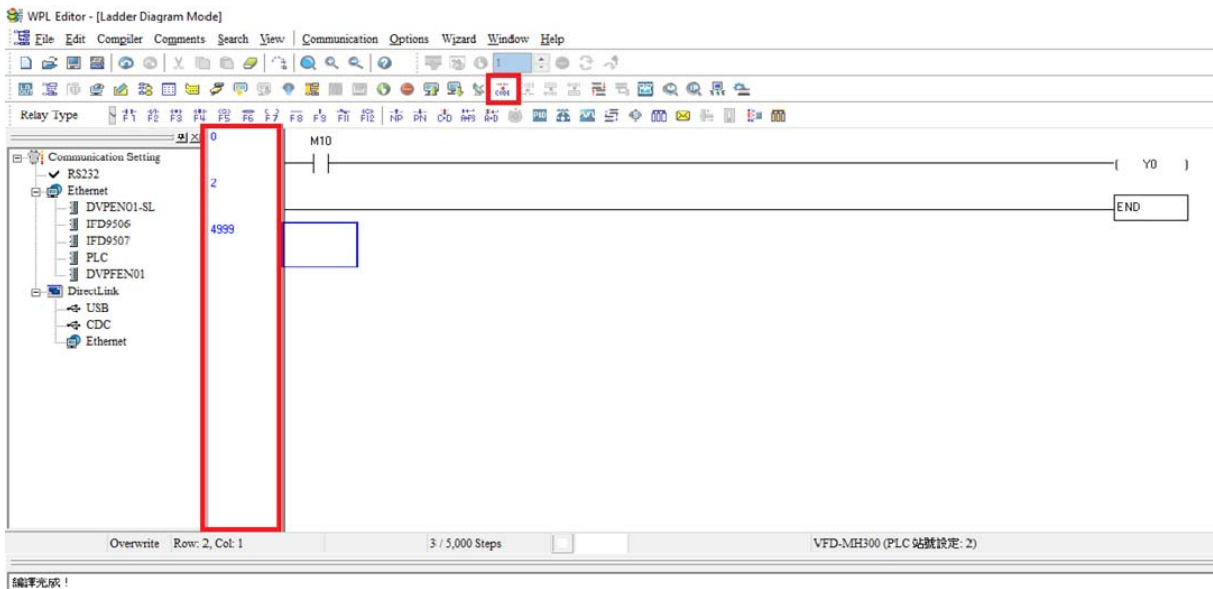





Figure 16-18

## 16-3-5 Program download

After inputting a program using WPLSoft, select compile . After completing compilation, select the  to download a program. WPLSoft will perform program download with the online PLC in the communications format specified in communications settings.

## 16-3-6 Program monitoring

While confirming that the PLC is in the Run mode, after downloading a program, click on  in the communications menu and select start ladder diagram control (see figure below)

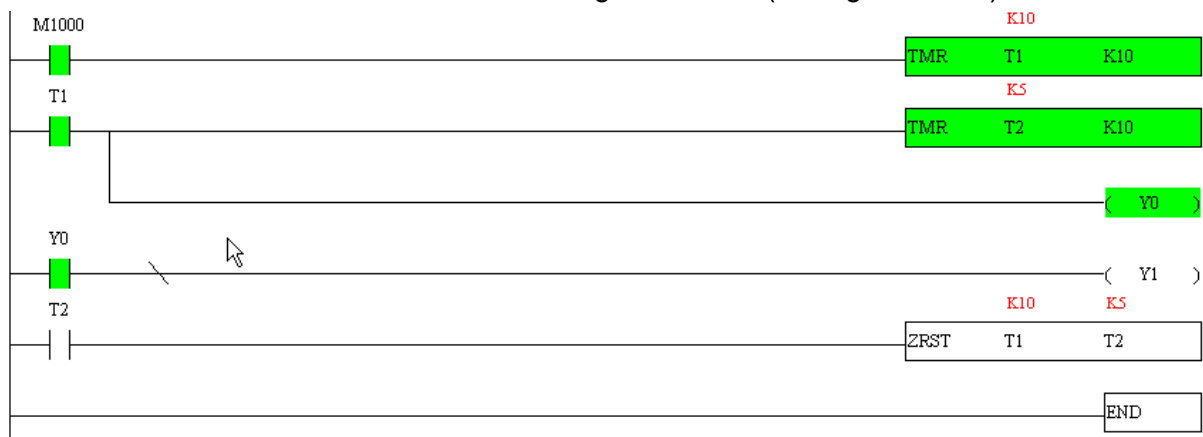

## 16-4 Basic principles of PLC ladder diagrams

### 16-4-1 Schematic diagram of PLC ladder diagram program scanning

Output results are calculated on the basis of the ladder diagram configuration (internal devices will have real-time output before results are sent to an external output point)

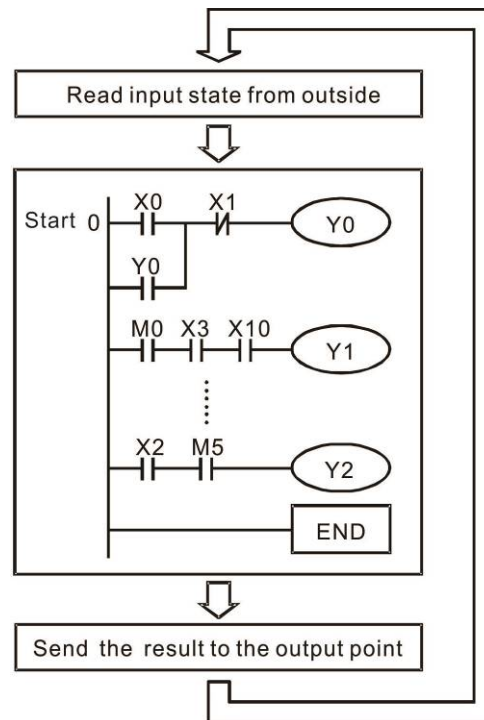

Repeated implementation

### 16-4-2 Introduction to ladder diagrams

Ladder diagrams comprise a graphic language widely applied in automatic control, and employs common electrical control circuit symbols. After a ladder diagram editor has been used to create a ladder pattern, PLC program designed is completed. The use of a graphic format to control processes is very intuitive, and is readily accepted by personnel who are familiar with electrical control circuit technology. Many of the basic symbols and actions in a ladder diagram comprise commonly seen electrical devices in conventional automatic control power distribution panels, such as buttons, switches, relays, timers, and counters.

**Internal PLC devices:** The types and quantities of internal PLC devices vary in different brands of products. Although these internal devices use the same names as conventional electrical control circuit elements such as relays, coils, and contacts, a PLC does not actually contain these physical devices, and they instead correspond to basic elements in the PLC's internal memory (bits). For instance, if a bit is 1, this may indicate that a coil is electrified, and if that bit is 0, it will indicate that the coil is not electrified. An N.O. contact (Normal Open, or contact a) can be used to directly read the value of the corresponding bit, and an N.C. contact (Normal Close, or contact b) can be used to obtain the inverse of the bit's value. Multiple relays occupy multiple bits, and 8 bits comprise one byte; two bytes comprise one word, and two words comprise a double word. When multiple relays are processing at the same time (such as addition/ subtraction or displacement, etc.), a byte, word, or double word can be used. Furthermore, a PLC contains two types of internal devices: a timer and a counter. It not only has a coil, but can count time and numerical values. Because of this, when it is necessary to process some numerical values, these values are usually in the form of bytes, words, or double words.











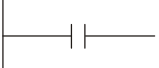
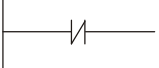
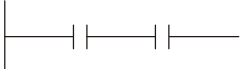

The various internal devices in a PLC all account for a certain quantity of storage units in the PLC's storage area. When these devices are used, the content of the corresponding storage area is read in the form of bits, bytes, or words.

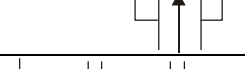
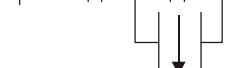

#### Introduction to the basic internal devices in a PLC

Device type	Description of Function
Input Relay	<p>An input relay constitutes the basic unit of storage in a PLC's internal memory corresponding to an external input point (which serves as a terminal connecting with an external input switch and receiving external input signals). It is driven by external input signals, to which it assigns values of 0 or 1. A program design method cannot change the input relay status, and therefore cannot rewrite the corresponding basic units of an input relay, and WPLSoft cannot be used to perform compulsory On/Off actions. A relay's contacts (contacts a and b) can be used an unlimited number of times. An input relay with no input signal must be left idle and cannot be used for some other purpose.</p> <p><input checked="" type="checkbox"/> Device indicated as: X0, X1, X7, X10, X11, etc. This device is expressed with the symbol "X" , and a device's order is indicated with an octal number. Please refer to Chapter 16-3-2 I/O device explanation for input point numbers.</p>
Output Relay	<p>An output relay constitutes the basic unit of storage in a PLC's internal memory corresponding to an external output point (which connects with an external load). It may be driven by an input relay contact, a contact on another internal device, or its own contacts. It uses one NO contact to connect with external loads or other contacts, and, like input contacts, can use the contact an unlimited number of times. An output relay with no input signal will be idle, but may be used an internal relay if needed.</p> <p><input checked="" type="checkbox"/> Device indicated as: Y0, Y1,...Y7, Y10, Y11,...etc. This device is expressed with the symbol "Y" , and a device's order is indicated with an octal number. Please refer to Chapter 16-3-2 I/O device explanation for output point numbers.</p>
Internal Relay	<p>Internal relays have no direct connection with the outside. These relays are auxiliary relays inside a PLC. Their function is the same as that of an auxiliary (central) relay in an electrical control circuit: Each auxiliary relay corresponding to a basic unit of internal storage; they can be driven by input relay contacts, output relay contacts, and the contacts of other internal devices. An internal auxiliary relay's contact can also be used an unlimited number of times. Internal relays have no outputs to outside, and must output via an output point.</p> <p><input checked="" type="checkbox"/> Device indicated as: M0, M1 to M799, etc. This device is expressed as the symbol "M" , and its order is expressed as a decimal number.</p>
Counter	<p>A counter is used to perform counting operations. A count setting value (such as the number of pulses to be counted) must be assigned when a counter is used. A counter contains a coil, contact, and a counting storage device. When the coil goes from Off to On, this indicates that the counter has an input pulse, and one is added to its count. There are 16 bits that can be employed by the user.</p> <p><input checked="" type="checkbox"/> Device indicated as: C0, C1 to C79, etc. This device is expressed as the symbol "C" , and its order is expressed as a decimal number.</p>
Timer	<p>A timer is used to complete control of timing. The timer contains a coil, contact, and a time value register. When the coil is electrified, if the preset time is reached, the contact will be actuated (contact a will close, contact b will open), and the timer's fixed value will be given by the set value. Timer has a regulated clock cycle (timing units: 100 ms). As soon as power to the coil is cut off, the contact will no longer be actuated (contact a will open, contact b will close), and the original timing value will return to zero.</p> <p><input checked="" type="checkbox"/> Device indicated as: T0, T1 to T159, etc. The device is expressed as the symbol "T" , and its order is expressed as a decimal number.</p>

Device type	Description of Function
Data register	<p>When a PLC is used to perform various types of sequence control and set time value and count value control, it most commonly perform data processing and numerical operations, and data registers are used exclusively for storage of data and various parameters. Each data register contains 16 bits of binary data, which means that it can store one word. Two data registers with adjacent numbers can be used to process double words.</p> <p><input checked="" type="checkbox"/> Device indicated as: D0, D1 to D399, etc. The device is expressed as the symbol "D" , and its order is expressed as a decimal number.</p>

### Ladder diagram images and their explanation

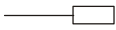
Ladder diagram structures	Explanation of commands	Command	Using Device
	NO switch, contact a	LD	X · Y · M · T · C
	NC switch, contact b	LDI	X · Y · M · T · C
	Series NO	AND	X · Y · M · T · C
	Series NC	ANI	X · Y · M · T · C
	Parallel NO	OR	X · Y · M · T · C
	Parallel NC	ORI	X · Y · M · T · C
	Positive edge-triggered switch	LDP	X · Y · M · T · C
	Negative edge-triggered switch	LDF	X · Y · M · T · C
	Positive edge-triggered series	ANDP	X · Y · M · T · C
	Negative edge-triggered series	ANDF	X · Y · M · T · C
	Positive edge-triggered parallel	ORP	X · Y · M · T · C
	Negative edge-triggered parallel	ORF	X · Y · M · T · C
	Block series	ANB	N/A
	Block parallel	ORB	N/A
	Multiple outputs	MPS MRD MPP	N/A
	Coil driven output commands	OUT	Y · M

Ladder diagram structures	Explanation of commands	Command	Using Device
	Some basic commands, applications commands	Some basic commands Applications commands	
	Inverted logic	INV	N/A

### 16-4-3 Overview of PLC ladder diagram editing

The program editing method begins from the left busbar and proceeds to the right busbar (the right busbar is omitted when editing using WPLSoft). Continue to the next row after completing each row; there is a maximum of 11 contacts on each row. If this is not sufficient, a continuous line will be generated to indicate the continued connection and more devices can be added. A continuous series of numbers will be generated automatically and identical input points can be used repeatedly. See figure below:

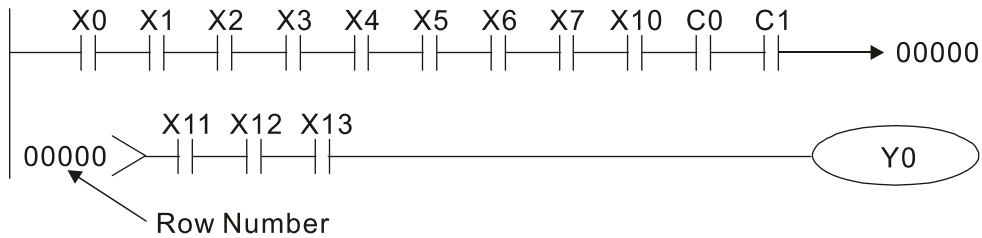

The ladder diagram programming method involves scanning from the upper left corner to the lower right corner. The coils and applications command-computing box are handled in the output, and the ladder diagram is placed on the farthest right. Taking the figure below as an example, we can gradually analyze the procedural sequence of the ladder diagram. The number in the upper right corner gives the sequential order.

Explanation of command sequence

- 1 LD X0
- 2 OR M0
- 3 AND X1
- 4 LD X3
- AND M1
- ORB
- 5 LD Y1
- AND X4
- 6 LD T0
- AND M3
- ORB
- 7 ANB
- 8 OUT Y1
- TMR T0 K10

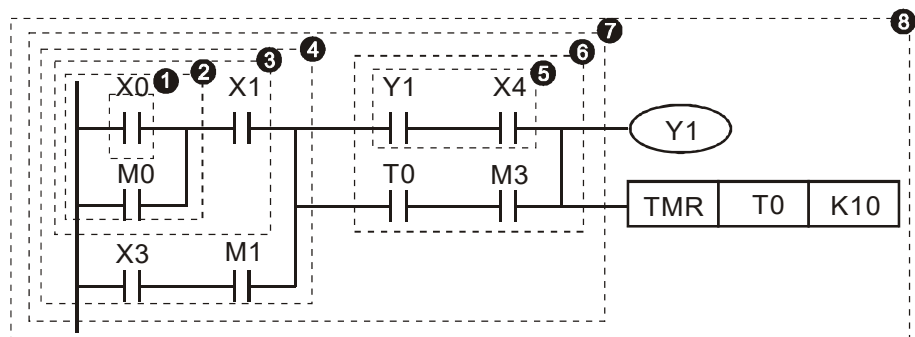

Explanation of basic structure of ladder diagrams

**LD (LDI) command:** An LD or LDI command is given at the start of a block.

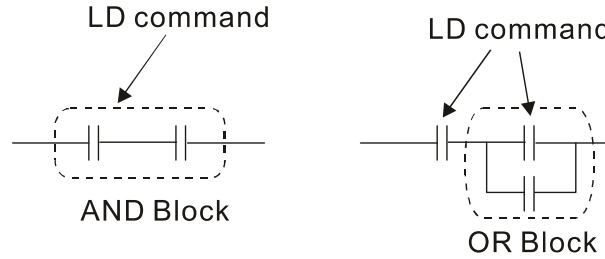

LDP and LDF have this command structure, but there are differences in their action state. LDP, LDF only act at the rising or falling edge of a conducting contact. (see figure below):

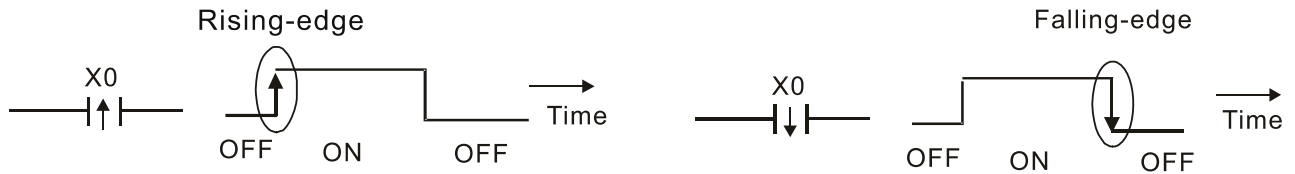

**AND (ANI) command:** A series configuration in which a single device is connected with one device or a block.



ANDP, ANDF also have structures like this, but their action occurs at the rising and falling edge.

**OR (ORI) command:** A single device is connected with one device or a block.

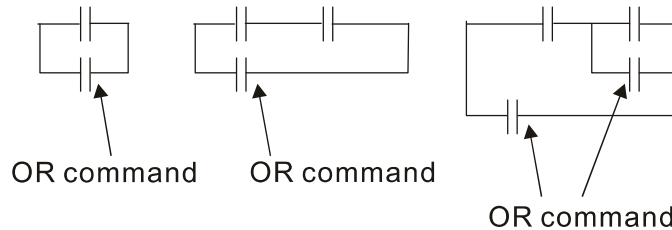

ORP, ORF also have identical structures, but their action occurs at the rising and falling edge.

**ANB command:** A configuration in which one block is in series with one device or block.

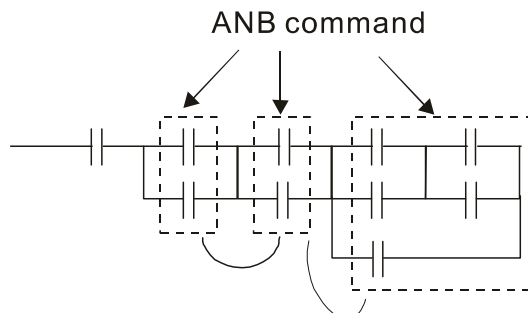



**ORB command:** A configuration in which one block is in parallel with one device or block.

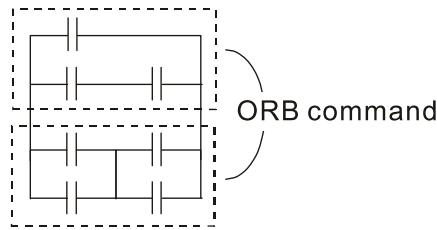

In the case of ANB and ORB operations, if a number of blocks are connected, they should be combined to form a block or network from the top down or from left to right.

**MPS, MRD, MPP commands:** Branching point memory for multiple outputs, enabling multiple, different outputs. The MPS command begins at a branching point, where the so-called branching point refers to the intersection of horizontal and vertical lines. We have to rely on the contact status along a single vertical line to determine whether the next contact can give a memory command. While each contact is basically able to give memory commands, in view of convenience and the PLC's capacity restrictions, this can be omitted from some places when converting a ladder diagram. The structure of the ladder diagram can be used to judge what kinds of contact memory commands are used.

MPS can be distinguished by use of the "┣" symbol; this command can be used consecutively for up to 8 times. The MRD command is read from branching point memory; because logic states along any one vertical line must be the same, in order to continue analysis of other ladder diagrams, the original contact status must be read.

MRD can be distinguished by use of the "┣" symbol. The MPP command is read from the starting state of the uppermost branching point, and it is read from the stack (pop); because it is the final command along a vertical line, it indicates that the state of the vertical line can be concluded.

MPP can be distinguished by use of the "┣" symbol. Although there should basically be no errors when using the foregoing analytical approach, the compiling program may sometimes omit identical state output, as shown in the following figure:

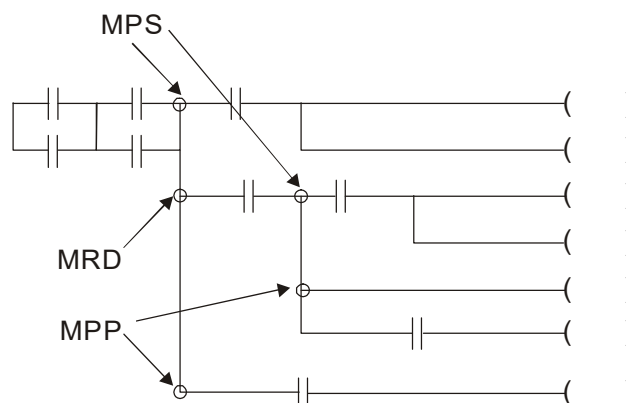

## 16-4-4 Commonly used basic program design examples

### Start, stop, and protection

Some applications may require a brief close or brief break using the buttons to start and stop equipment. A protective circuit must therefore be designed to maintain continued operation in these situations; this protective circuit may employ one of the following methods:

#### Example 1: Priority stop protective circuit

When the start NO contact X1=On, and the stop NC contact X2=Off, Y1=On; if X2=On at this time, coil Y1 will no longer be electrified, and this is therefore referred to as priority stop.

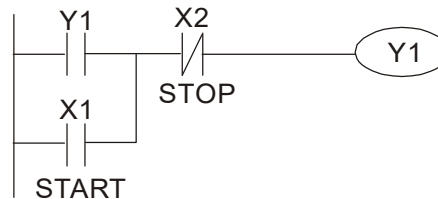

#### Example 2: Priority start protective circuit

When start NO contact X1=On, and the stop NC contact X2=Off, Y1=On, and coil Y1 will be electrified and protected. At this time, if X2=On, coil Y1 will still protect the contact and continue to be electrified, and this is therefore priority start.

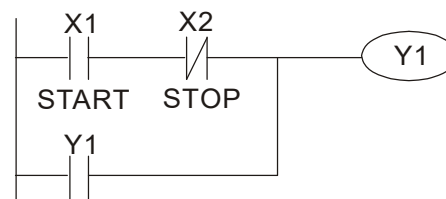

#### Example 3: Setting (SET) and reset (RST) command protective circuit

The following figure shows a protective circuit composed of RST and SET commands.

Priority stop occurs when the RST command is placed after the SET command. Because the PLC executes programs from the top down, at the end of the program, the state of Y1 will indicate whether coil Y1 is electrified. When X1 and X2 are both actuated, Y1 will lose power, and this is therefore priority stop.

Priority start occurs when the SET command is placed after the RST command. When X1 and X2 are both actuated, Y1 will be electrified, and this is therefore priority start.

Top priority of stop

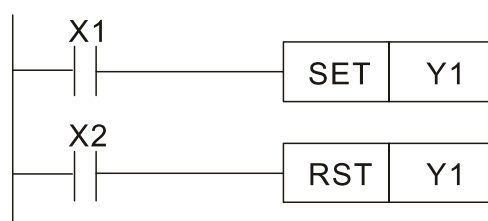

Top priority of start

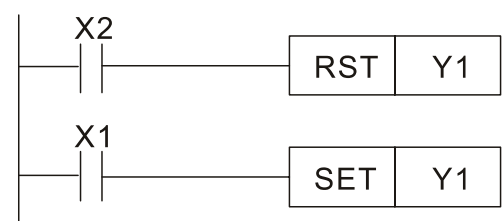

## Commonly used control circuits

### Example 4: Conditional control

X1, X3 are respectively start/ stop Y1, and X2 & X4 are respectively start/ stop Y2; all have protective circuits. Because Y1's NO contact is in series with Y2's circuit, it becomes an AND condition for the actuation of Y2. The action of Y1 is therefore a condition for the action of Y2, and Y1 must be actuated before Y2 can be actuated.

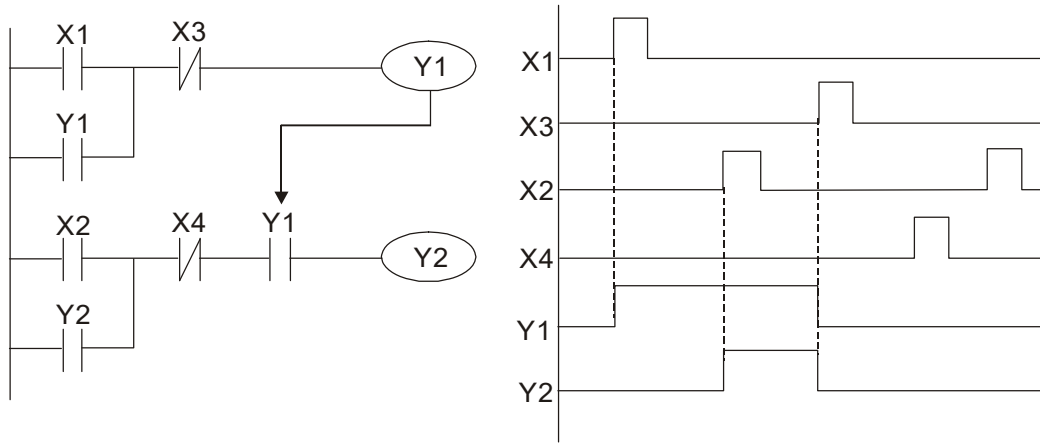

### Example 5: Interlocking control

The figure below shows an interlocking control circuit. Depending on which of the start contacts X1, X2 is valid first, the corresponding output Y1 or Y2 will be actuated, and when one is actuated, the other will not be actuated. This implies that Y1 and Y2 cannot be actuated at the same time (interlocking effect). Even if both X1 and X2 are valid at the same time, because the ladder diagram program is scanned from the top down, it is impossible for Y1 and Y2 to be actuated at same time. This ladder diagram assigns priority only to Y1.

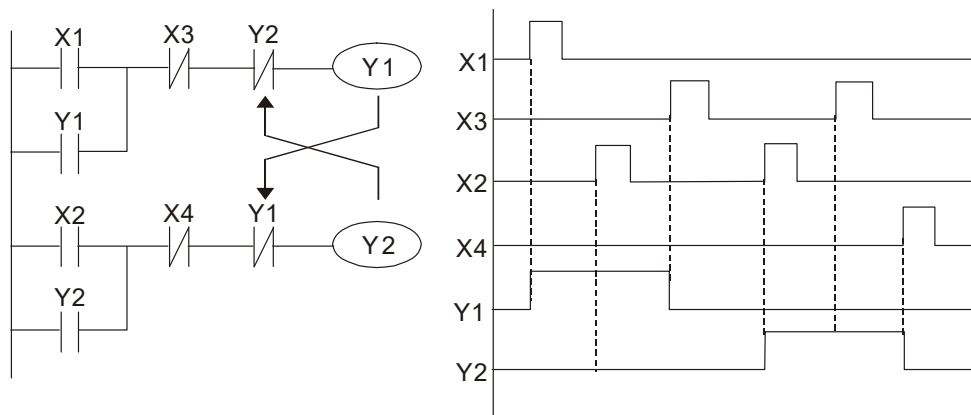

Example 6: Sequence control

If the NC contact of Y2 in the interlocking control configuration of example 5 is put in series with the Y1 circuit, so that it is an AND condition for actuation of Y1 (see figure below), not only is Y1 a condition for the actuation of Y2 in this circuit, the actuation of Y2 will also stop the actuation of Y1. This configuration confirms the actuation order of Y1 and Y2.

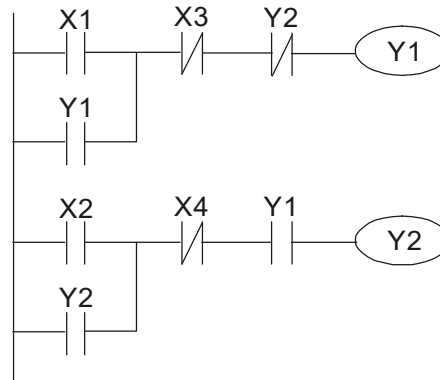

Example 7: Oscillating circuit

Oscillating circuit with a period of  $\Delta T + \Delta T$

The figure below shows a very simple ladder diagram. When starting to scan the Y1 NC contact, because the Y1 coil has lost power, the Y1 NC contact will be closed. When the Y1 coil is then scanned, it will be electrified, and the output will be 1. When the Y1 NC contact is scanned in the scanning cycle, because Y1 coil is electrified, the Y1 NC contact will be opened, the Y1 coil will then lose power, and the output will be 0. Following repeated scanning, the output of Y1 coil will have an oscillating waveform with a period of  $\Delta T$  (On) +  $\Delta T$  (Off).

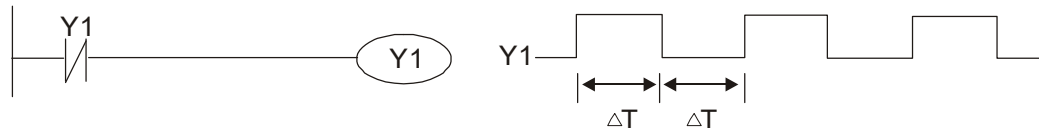

Oscillating circuit with a period of  $nT + \Delta T$

The program of the ladder diagram shown below uses timer T0 to control coil Y1's electrified time. After Y1 is electrified, it causes timer T0 to close during the next scanning cycle, which will cause the output from Y1 to have the oscillating waveform shown in the figure below. Here n is the timer's decimal setting value, and T is the clock cycle of the timer.

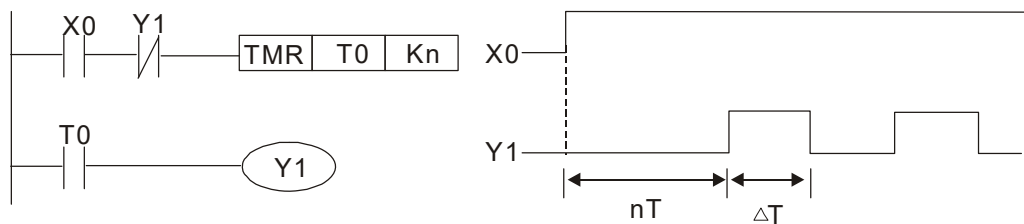

Example 8: Flashing circuit

The following figure shows an oscillating circuit of a type commonly used to cause an indicator light to flash or a buzzer to buzz. It uses two timers to control the On and Off time of Y1 coil. Here  $n_1$ ,  $n_2$  are the timing set values of T1 and T2, and T is the clock cycle of the timer.

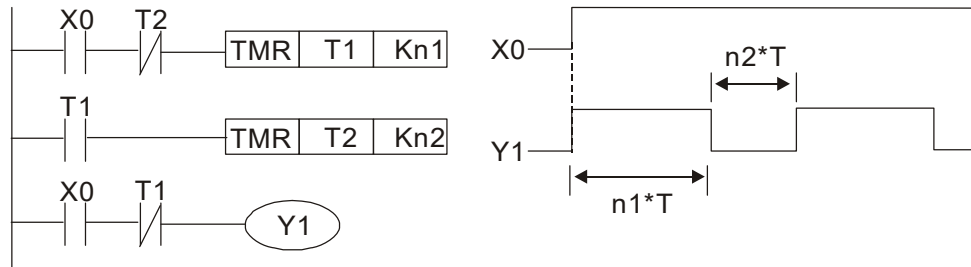

Example 9: Triggering circuit

In the figure below, a command consisting of the differential of the rising edge of X0 causes coil M0 to generate a single pulse for  $\Delta T$  (length of one scanning cycle), and coil Y1 is electrified during this scanning cycle. Coil M0 loses power during the next scanning cycle, and NC contact M0 and NC contact Y1 are both closed. This causes coil Y1 to stay in an electrified state until there is another rising edge in input X0, which again causes the electrification of coil M0 and the start of another scanning cycle, while also causing coil Y1 to lose power, etc. The sequence of these actions can be seen in the figure below. This type of circuit is commonly used to enable one input to perform two actions in alternation. It can be seen from the time sequence in the figure below that when input X0 is a square wave signal with a period of T, the output of coil Y1 will be a square wave signal with a period of 2T.

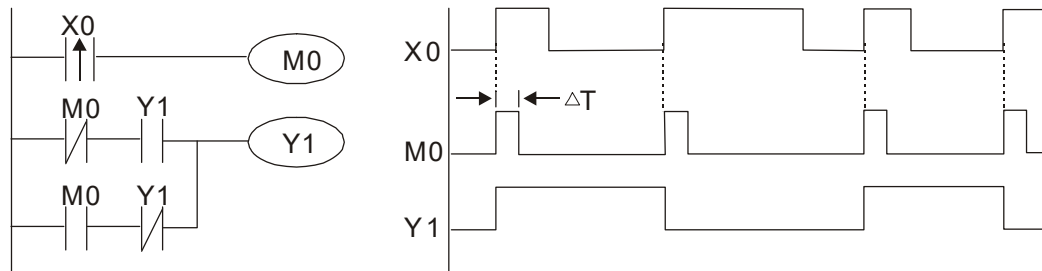

Example 10: Delay circuit

When input X0 is On, because the corresponding NC contact will be Off, the timer T10 will be in no power status, and output coil Y1 will be electrified. T10 will receive power and begin timing only after input X0 is Off, and output coil Y1 will be delayed for 100 sec. ( $K1000 \times 0.1 \text{ sec.} = 100 \text{ sec.}$ ) before losing power; please refer to the sequence of actions in the figure below.

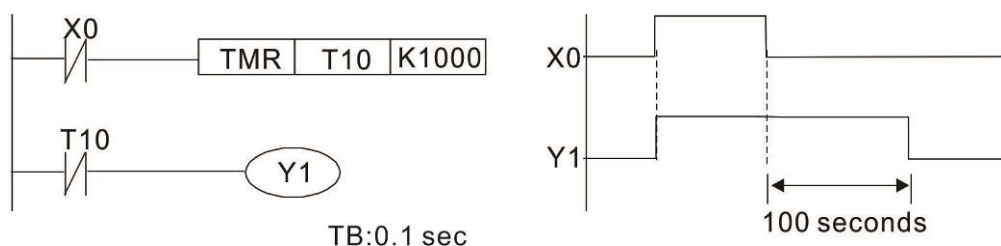

Example 11: The open/ close delay circuit is composed of two timers; output Y4 will have a delay whether input X0 is On or Off.

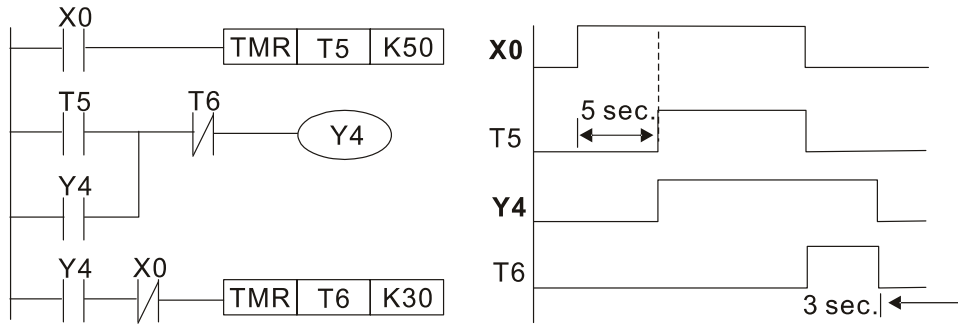

Example 12: Extended timing circuit

In the circuit in the figure on the left, the total delay time from the moment input X0 closes to the time output Y1 is electrified is  $(n_1+n_2)*T$ , where T is the clock cycle. Timers: T11, T12; clock cycle: T.

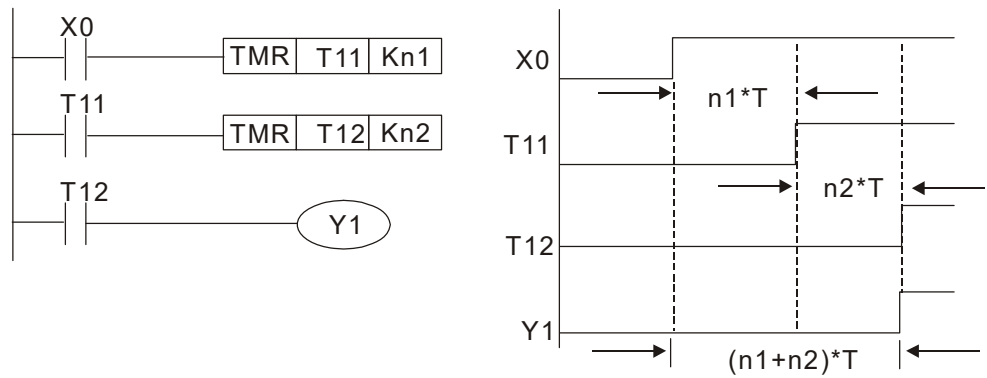

## 16-5 Various PLC device functions

Item	Specifications	Notes
Algorithmic control method	Program stored internally, alternating back-and-forth scanning method	
Input/ output control method	When it starts again after ending (after execution to the END command), the input/ output has an immediate refresh command	
Algorithmic processing speed	Basic commands (several $\mu$ s);	Applications command (1 to several tens of $\mu$ s)
Programming language	Command + ladder diagram	
Program capacity	10000 steps	
Input/ output terminal	Input (X): 10, output (Y): 4	This number of contacts constitutes C2000 input/ output contacts; other devices have different correspondences

Type	Device	Item	Range	Function	
Relay bit form	X	External input relay	X0–X17, 16 points, octal number	Total 32 points Corresponds to external input point	
	Y	External output relay	Y0–Y17, 16 points, octal number		Corresponds to external output point
	M	Auxiliary Relay	General Use	M0–M799, 800 points	Total 880 points Contact can switch On/ Off within the program
			Special purpose	M1000–M1079, 80 points	
	T	Timer	100ms timer	T0–T159, 160 points	Total 160 points Timers referred to by the TMR command; contact of the T with the same number will go On when the time is reached
C	Counter	16-bit counter, general use	C0–C79, 80 points	Total 80 points Counter referred to by the CNT command; contact of the C with the same number will go On when the count is reached	
Register word data	T	Current timer value	T0–T159, 160 points	The contact will be On when the time is reached	
	C	Current counter value	C0–C79, 16-bit counter 80 points	The counter contact will come On when the count is reached	
	D	Data Register	Used to maintain power Off	D0–D399, 400 points	Total 1400 points Used as data storage memory area
Special purpose			D1000–D1199, 200 points D2000–D2799, 800 points		
Constant	K	Decimal	Single-byte	Setting Range: K-32,768–K32,767	
		Double-byte	Setting Range: K-2,147,483,648–K2,147,483,647		
	H	Hexadecimal	Single-byte	Setting Range: H0000–HFFFF	
		Double-byte	Setting Range: H00000000–HFFFFFFFF		
Serial communications port (program write/read)			RS-485/ keypad port		
Input/output			Built-in three analog inputs and two analog outputs		
Function expansion module		Optional Accessories	EMC-D42A; EMC-R6AA; EMCD611A		
Communication Expansion Module		Optional Accessories	EMC-COP01,(CANopen)		

## 16-5-1 Introduction to device functions

### Input/ output contact functions

Input contact X functions: Input contact X is connected with an input device, and reads input signals entering the PLC. The number of times that contact a or b of input contact X is used in the program is not subject to restrictions. The On/ Off state of input contact X will change as the input device switches On and Off; a peripheral device (WPLSoft) cannot be used to force contact X On or Off.

### Output contact Y functions

The job of output contact Y is to send an On/Off signal to drive the load connected with output contact Y. Output contacts consist of two types: relays and transistors. While number of times that contact a or b of each output contact Y is used in the program is not subject to restrictions, it is recommended that the number of output coil Y be used only once in a program, otherwise the right to determine the output state when the PLC performs program scanning will be assigned to the program's final output Y circuit.

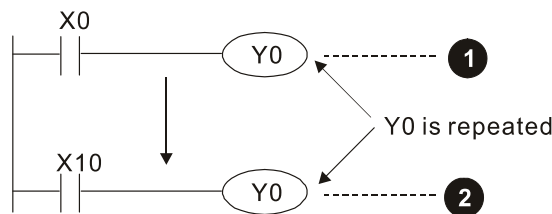

The output of Y0 will be decided by circuit ②, i.e. decided by ON/OFF of X10.

### Numerical value, constant [K]/ [H]

Constant	Single-byte	K	Decimal	K-32,768–K32,767
	Double-byte			K-2,147,483,648–K2,147,483,647
	Single-byte	H	Hexadecimal	H0000–HFFFF
	Double-byte			H00000000–HFFFFFFF

The PLC can use five types of numerical values to implement calculations based on its control tasks; the following is an explanation of the missions and functions of different numerical values.

#### Binary Number, BIN

The PLC's numerical operations and memory employ binary numbers. Binary nibbles and relevant terms are explained as follows:

bit	Bits are the fundamental units of binary values, and have a state of either 1 or 0
Nibble	Comprised of a series of 4 bits (such as b3–b0); can be used to express a one-nibble decimal number 0–9 or hexadecimal number: 0–F.
Byte	Comprised of a series of two nibbles (i.e. 8 bits, b7–b0); can express a hexadecimal number: 00–FF.
Word	Comprised of a series of two bytes (i.e. 16 bits, b15–b0); can express a hexadecimal number with four nibbles: 0000–FFFF.
Double Word	Comprised of a series of two words (i.e. 32 bits, b31–b0); can express a hexadecimal number with eight nibbles: 00000000–FFFFFFFF

Relationship between bits, digits, nibbles, words, and double words in a binary system (see figure below):



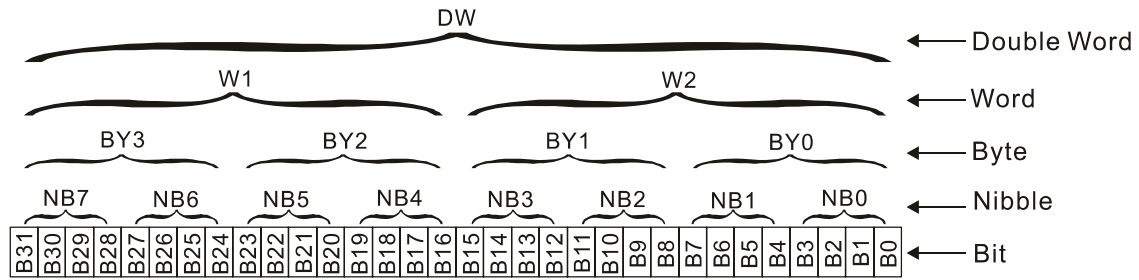

**Octal Number, OCT**

The external input and output terminals of a DVP-PLC are numbered using octal numbers

Example: External input: X0–X7 , X10–X17...(Device number table);

External output: Y0–Y7 , Y10–Y17...(Device number table)

**Decimal Number, DEC**

Decimal numbers are used for the following purposes in a PLC system:

- ☑ The setting values of timer T or counter C, such as TMR C0 K50. (K constant)
- ☑ The numbers of devices including M, T, C, or D, such as M10 or T30. (device number)
- ☑ Used as an operand in an application command, such as MOV K123 D0. (K constant)

**Binary Code Decimal, BCD**

Uses one nibble or 4 bits to express the data in a decimal number; a series of 16 bits can therefore express a decimal number with 4 nibbles. Chiefly used to read the input value of a fingerwheel numerical switch input or output a numerical value to a seven-segment display drive.

**Hexadecimal Number, HEX**

Applications of hexadecimal numbers in a PLC system: Used as operands in application commands, such as MOV H1A2B D0. (H constant)

**Constant K**

Decimal numbers are usually prefixed with a "K" in a PLC system, such as K100. This indicates that it is a decimal number with a numerical value of 100.

Exceptions: K can be combined with bit device X, Y, M, or S to produce data in the form of a nibble, byte, word, or double word, such as in the case of K2Y10 or K4M100. Here K1 represents a 4-bit combination, and K2–K4 variously represent 8, 12, and 16-bit combinations.

**Constant H**

Hexadecimal numbers are usually prefixed with the letter "H" in a PLC system, such as in the case of H100, which indicates a hexadecimal number with a numerical value of 100.

## Functions of auxiliary relays

Like an output relay Y, an auxiliary relay M has an output coil and contacts a and b, and the number of times they can be used in a program is unrestricted. Users can use an auxiliary relay M to configure the control circuit, but cannot use it to directly drive an external load. Auxiliary relays have the following two types of characteristics:

**Ordinary auxiliary relays:** Ordinary auxiliary relays will all revert to the Off state if a power outage occurs while the PLC is running, and will remain in the Off state if power is again turned down.

**Special purpose auxiliary relays:** Each special purpose auxiliary relay has its own specific use. Do not use any undefined special purpose auxiliary relays.

## Timer functions

Timers take 100 ms as their timing units. When the timing method is an upper time limit, when the current timer value = set value, power will be sent to the output coil. Timer setting values consist of decimal K values, and the data register D can also serve as a setting value.

Actual timer setting time = timing units \* set value

Counter features

Item	16-bit counter
Type	General Type
CT Direction:	Score
Setting	0–32,767
Designation of set value	Constant K or data register D
Change in current value	When the count reaches the set value, there is no longer a count
Output contact	When the count reaches the set value, the contact comes On and stays On
Reset	The current value reverts to 0 when an RST command is executed, and the contact reverts to Off
Contact actuation	All are actuated after the end of scanning

Counter functions

When a counter's counting pulse input signal goes Off→On, if the counter's current value is equal to the set value, the output coil will come On. The setting value will be a decimal K values, and the data register D can also serve as a setting value.

16-bit counter C0–C79:

- ☑ 16-bit counter setting range: K0–K32,767. (when K0 and K1 are identical, the output contact will immediately be On during the first count.)
- ☑ The current counter value will be cleared from an ordinary counter when power is shut off to the PLC.
- ☑ If the MOV command or WPLSoft is used to transmit a value greater than the set value to the C0 current value register, when the next X1 goes from Off→On, the C0 counter contact will change to On, and the current value will change to the set value.
- ☑ A counter's setting value may be directly set using a constant K or indirectly set using the value in register D (not including special data registers D1000–D1199 or D2000–D2799).
- ☑ If the set value employs a constant K, it may only be a positive number; the set value may be either a positive or a negative number if the value in data register D is used. The current counter value will change from 32,767 to -32,768 as the count continues to accumulate.

Example

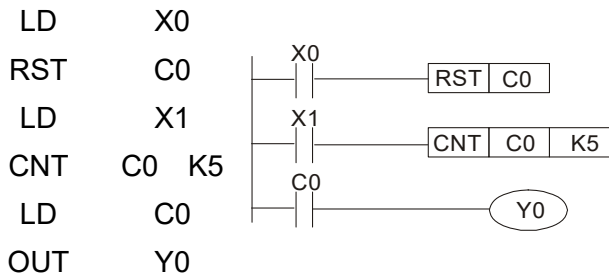

1. When X0=On and the RST command is executed, the current value of C0 will revert to 0, and the output contact will revert to Off.
2. When X1 changes from Off→On, the current value of the counter will execute an increase (add one).
3. When the count of counter C0 reaches the 4. set value K5, the contact C0 will come On, and the current value of C0= set value =K5. Afterwards, signal C0 triggered by X1 cannot be received, and the current value of C0 will remain K5.

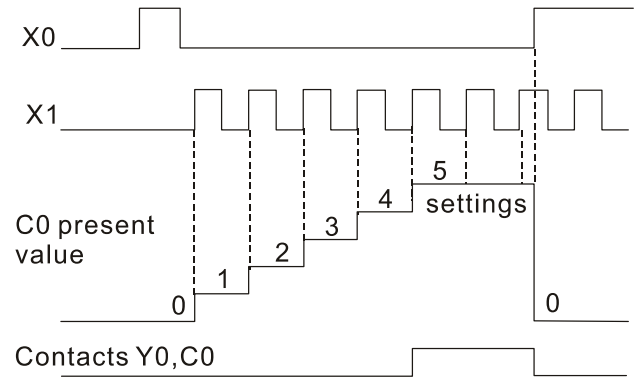

### 16-5-2 Introduction to special relay functions (special M)

R/W items: RO: read only function; RW: read and write function

Special M	Description of Function	R/W *
M1000	Operates monitor NO contact (contact a). NO while RUN, contact a. This contact is On while in the RUN state.	RO
M1001	Operates monitor NC contact (contact b). NC while RUN, contact b. This contact is Off while in the RUN state.	RO
M1002	Initiates a forward (the instant RUN is On) pulse. Initial pulse, contact a. Produces a forward pulse the moment RUN begins; its width = scan cycle	RO
M1003	Initiates a reverse (the instant RUN is Off) pulse. Initial pulse, contact a. Produces a reverse pulse the moment RUN ends; the pulse width = scan cycle	RO
M1004	Reserved	RO
M1005	Drive malfunction instructions	RO
M1006	Converter has no output (1 = no output, 0 = output)	RO
M1007	Drive direction FWD(0)/REV(1)	RO
M1008 -- M1010	--	--
M1011	10 ms clock pulse, 5ms On / 5ms Off	RO
M1012	100 ms clock pulse, 50ms On / 50ms Off	RO
M1013	1 sec. clock pulse, 0.5s On / 0.5s Off	RO
M1014	1 min. clock pulse, 30s On / 30s Off	RO
M1015	Frequency attained (when used together with M1025)	RO
M1016	Parameter read/write error	RO
M1017	Parameter write successful	RO
M1018	--	--

Special M	Description of Function	R/W *
M1019	--	--
M1020	Zero flag	RO
M1021	Borrow flag	RO
M1022	Carry flag	RO
M1023	Divisor is 0	RO
M1024	--	--
M1025	Target drive frequency = set frequency (ON) Target drive frequency =0 (OFF)	RW
M1026	Drive operating direction FWD(OFF) / REV(ON)	RW
M1027	Drive Reset	RW
M1028	--	--
M1029	--	--
M1030	--	--
M1031	Compulsory setting of the current PID integral value equal to D1019 (0 change, 1 valid)	RW
M1032	Compulsory definition of FREQ command after PID control	RW
M1033	--	--
M1034	Initiates CANopen real-time control	RW
M1035	Initiates internal communications control	RW
M1036	Ignore calendar error	RW
M1037	--	--
M1038	MI8 count begins	RW
M1039	Reset MI8 count value	RW
M1040	Excitation (Servo On)	RW
M1041	--	--
M1042	Quick stop	RW
M1043	--	--
M1044	Pause (Halt)	RW
M1045	--	--
M1047	--	--
M1048	Move to new position	RW
M1049	--	--
M1050	Absolute position / relative position (0: relative/1: absolute)	RW
M1051	--	--
M1052	Lock frequency (lock, frequency locked at the current operating frequency)	RW
M1053	--	--
M1054	Compulsory reset of absolute position	RW
M1055	Search Origin	RW
M1056	Excitation ready (Servo On Ready)	RO
M1057	--	--
M1058	On Quick Stopping	RO
M1059	CANopen Master setting complete	RO
M1060	CANopen Currently initializing slave station	RO
M1061	CANopen Slave station initialization failure	RO
M1062	--	--
M1063	Torque attained	RO
M1064	Target reached	RO
M1065	Read/write CANopen data time out	RO
M1066	Read/write CANopen data complete	RO
M1067	Read/write CANopen data successful	RO
M1068	Calendar calculation error	RO
M1069	--	--
M1070	Return home complete	RO
M1071	Homing error	RO

Special M	Description of Function	R/W *
M1072 – M1075	--	--
M1076	Calendar time error or refresh time out	RO
M1077	485 Read/write complete	RO
M1078	485 Read-write error	RO
M1079	485 Communications time out	RO
M1090	AUTO	RO
M1091	OFF	RO
M1092	HAND	RO
M1100	LOCAL	RO
M1101	REMOTE	RO
M1168	SBOV BCD and BIN mode switch	RW
M1260	PLC PID1 Enable	RW
M1262	PLC PID1 integral positive value limit	RW
M1270	PLC PID2 Enable	RW
M1272	PLC PID2 integral positive value limit	RW

### 16-5-3 Introduction to special register functions (special D)

Special D	Description of Function	R/W *
D1000	--	--
D1001	Device system program version	RO
D1002	Program capacity	RO
D1003	Total program memory content	RO
D1004 – D1009	--	--
D1010	Current scan time (units: 0.1 ms)	RO
D1011	Minimum scan time (units: 0.1 ms)	RO
D1012	Maximum scan time (units: 0.1 ms)	RO
D1013 – D1017	--	--
D1018	Current integral value	RO
D1019	Compulsory setting of PID I integral	RW
D1020	Output frequency (0.000–600.00Hz)	RO
D1021	Output current (####.#A)	RO
D1022	AI AO DI DO Expansion card number 0: No expansion card 4: AC input card (6 in) (EMC-D611A) 5: Digital I/O Card (4 in 2 out ) (EMC-D42A) 6: Relay card (6 out) (EMC-R6AA) 11: Analog I/O Card (2 in 2 out) (EMC-A22A)	RO
D1023	Communication expansion card number 0: No expansion card 1: DeviceNet Slave (CMC-DN01) 2: Profibus-DP Slave (CMC-PD01) 3: CANopen Slave (EMC-COP01) 4: Modbus-TCP Slave (CMC-MOD01) 5: EtherNet/IP Slave (CMC-EIP01) 12: PROFINET Slave (CMC-PN01)	RO
D1024 – D1026	--	--

Special D	Description of Function	R/W *
D1027	PID calculation frequency command (frequency command after PID calculation)	RO
D1028	AVI value (0.00–100.00%)	RO
D1029	ACI value (0.0–100.00%)	RO
D1030	AUI value (-100.0–100.00%)	RO
D1031	C series: extension card AI10 (0.0–100.0%)	RO
D1032	C series: extension card AI11 (0.0–100.0%)	RO
D1033 – D1035	--	--
D1036	Servo error bit	RO
D1037	Drive output frequency	RO
D1038	DCBUS voltage	RO
D1039	Output voltage	RO
D1040	Analog output value AFM1 (-100.00–100.00%)	RW
D1041	C series: extension card AO10 (0.0–100.0%)	RW
D1042	C series: extension card AO11 (0.0–100.0%)	RW
D1043	Can be user-defined (will be displayed on panel when Pr. 00-04 is set as 28; display method is C xxx)	RW
D1044	--	-
D1045	Analog output value AFM2 (-100.00–100.00%)	RW
D1046 – D1049	--	--
D1050	Actual Operation Mode 0: Speed 1: Position 2: Torque 3: Homing Origin	RO
D1051	Encoder Pulses L	RO
D1052	Encoder Pulses H	RO
D1053	Actual torque	RO
D1054	MI8 current calculated count value (Low Word)	RO
D1055	MI8 current calculated count value (High Word)	RO
D1056	Rotational speed corresponding to MI8	RO
D1057	MI8's rotational speed ratio	RW
D1058	MI8 refresh rate (ms) corresponding to rotational speed	RW
D1059	Number of nibbles of rotational speed corresponding to MI8 (0–3)	RW
D1060	Operation Mode setting 0: Speed 1: Position 2: Torque 3: Homing Origin	RW
D1061	485 COM1 communications time out time (ms)	RW
D1062	Torque command (torque limit in speed mode)	RW
D1063	Year (Western calendar) (display range 2000–2099) (must use KPC-CC01)	RO
D1064	Week (display range 1–7) (must use KPC-CC01)	RO
D1065	Month (display range 1–12) (must use KPC-CC01)	RO
D1066	Day (display range 1–31) (must use KPC-CC01)	RO
D1067	Hour (display range 0–23) (must use KPC-CC01)	RO
D1068	Minute (display range 0–59) (must use KPC-CC01)	RO
D1069	Second (display range 0–59) (must use KPC-CC01)	RO
D1100	Target frequency	RO
D1101	Target frequency (must be operating)	RO
D1102	Reference frequency	RO
D1103	Target L	RO
D1104	Target H	RO

Special D	Description of Function	R/W *
D1105	Target torque	RO
D1106	--	--
D1107	$\pi$ (Pi) Low word	RO
D1108	$\pi$ (Pi) High word	RO
D1109	Random number	RO
D1110	Internal node communications number (set number of slave stations to be controlled)	RW
D1111	Actual position (Low word)	RO
D1112	Actual position (High word)	RO
D1113	--	RO
D1114	--	--
D1115	Internal node synchronizing cycle (ms)	RO
D1116	Internal node error (bit0 = Node 0, bit1 = Node 1,...bit7 = Node 7)	RO
D1117	Internal node online correspondence (bit0 = Node 0, bit1 = Node 1,...bit7 = Node 7)	RO
D1118	--	--
D1119	--	--
D1120	Internal node 0 control command	RW
D1121	Internal node 0 mode	RW
D1122	Internal node 0 reference command L	RW
D1123	Internal node 0 reference command H	RW
D1124	--	--
D1125	--	--
D1126	Internal node 0 status	RO
D1127	Internal node 0 reference status L	RO
D1128	Internal node 0 reference status H	RO
D1129	--	--
D1130	Internal node 1 control command	RW
D1131	Internal node 1 mode	RW
D1132	Internal node 1 reference command L	RW
D1133	Internal node 1 reference command H	RW
D1134	--	--
D1135	--	--
D1136	Internal node 1 status	RO
D1137	Internal node 1 reference status L	RO
D1138	Internal node 1 reference status H	RO
D1139	--	--
D1140	Internal node 2 control command	RW
D1141	Internal node 2 mode	RW
D1142	Internal node 2 reference command L	RW
D1143	Internal node 2 reference command H	RW
D1144	--	--
D1145	--	--
D1146	Internal node 2 status	RO
D1147	Internal node 2 reference status L	RO
D1148	Internal node 2 reference status H	RO
D1149	--	--
D1150	Internal node 3 control command	RW
D1151	Internal node 3 mode	RW
D1152	Internal node 3 reference command L	RW
D1153	Internal node 3 reference command H	RW
D1154	--	--
D1155	--	--
D1156	Internal node 3 status	RO
D1157	Internal node 3 reference status L	RO

Special D	Description of Function	R/W *
D1158	Internal node 3 reference status H	RO
D1159	--	--
D1160	Internal node 4 control command	RW
D1161	Internal node 4 mode	RW
D1162	Internal node 4 reference command L	RW
D1163	Internal node 4 reference command H	RW
D1164	--	--
D1165	--	--
D1166	Internal node 4 status	RO
D1167	Internal node 4 reference status L	RO
D1168	Internal node 4 reference status H	RO
D1169	--	--
D1170	Internal node 5 control command	RW
D1171	Internal node 5 mode	RW
D1172	Internal node 5 reference command L	RW
D1173	Internal node 5 reference command H	RW
D1174	--	RW
D1175	--	--
D1176	Internal node 5 status	--
D1177	Internal node 5 reference status L	RO
D1178	Internal node 5 reference status H	RO
D1179	--	--
D1180	Internal node 6 control command	RW
D1181	Internal node 6 mode	RW
D1182	Internal node 6 reference command L	RW
D1183	Internal node 6 reference command H	RW
D1184	--	--
D1185	--	--
D1186	Internal node 6 status	RO
D1187	Internal node 6 reference status L	RO
D1188	Internal node 6 reference status H	RO
D1189	--	--
D1190	Internal node 7 control command	RW
D1191	Internal node 7 mode	RW
D1192	Internal node 7 reference command L	RW
D1193	Internal node 7 reference command H	RW
D1194	--	--
D1195	--	--
D1196	Internal node 7 status	RO
D1197	Internal node 7 reference status L	RO
D1198	Internal node 7 reference status H	RO
D1199	--	--

Special D	Description of Function	Default	R/W *
D1200	PID 1 Mode: 0: Basic mode	0	RW
D1201	PID 1 Target selection: 0: Refer to D1202 1: AVI 2: ACI 3: AUI	0	RW
D1202	PID 1 Target value (0.00%–100.00%)	5000	RW



Special D	Description of Function	Default	R/W *
D1203	PID 1 Feedback selection: 0: Refer to D1204 1: AVI 2: ACI 3: AUI	1	RW
D1204	PID 1 Feedback value (0.00%–100.00%)	0	RW
D1205	PID 1 P value (decimal 2 points)	10	RW
D1206	PID 1 I value (decimal 2 points)	1000	RW
D1207	PID 1 D value (decimal 2 points)	0	RW
D1209	PID 1 Max. limit	10000	RW
D1215	PID 1 Calculation (decimal 2 points)	0	RO
D1220	PID2 Mode: 0: Basic mode	0	RW
D1221	PID 2 Target selection: 0: Refer to D1202 1: AVI 2: ACI 3: AUI	0	RW
D1222	PID 2 Target value (0.00%–100.00%)	5000	RW
D1223	PID 2 Feedback selection: 0: Refer to D1204 1: AVI 2: ACI 3: AUI	1	RW
D1224	PID 2 Feedback value (0.00%–100.00%)	0	RW
D1225	PID 2 P value (decimal 2 points)	10	RW
D1226	PID 2 I value (decimal 2 points)	1000	RW
D1227	PID 2 D value (decimal 2 points)	0	RW
D1229	PID 2 Max. limit	10000	RW
D1235	PID 2 Calculation (decimal 2 points)	0	RO

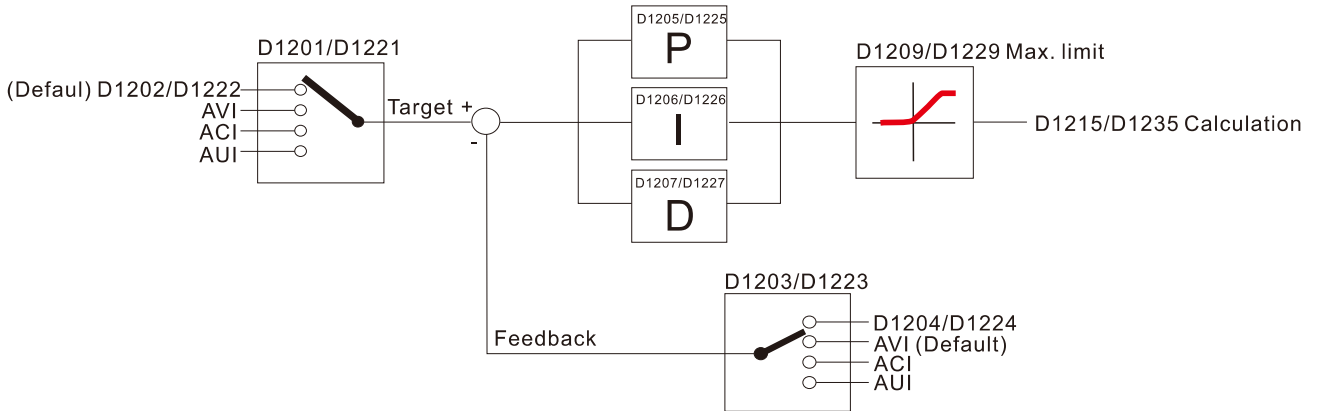

The following is CANopen Master's special D (Allow writing only when PLC is in STOP state)

n = 0–7

Special D	Description of Function	PDO Map	Power off Memory	Default	R/W
D1070	Channel opened by CANopen initialization (bit0=Machine code0 ...)	NO	NO	0	R
D1071	Error channel occurring in CANopen initialization process (bit0=Machine code0 ...)	NO	NO	0	R
D1072	Reserved	-	-		-
D1073	CANopen break channel (bit0=Machine code0 ...)	NO	NO		R
D1074	Error code of master error 0: No error 1: Slave station setting error 2: Synchronizing cycle setting error (too small)	NO	NO	0	R
D1075	Reserved	-	-		-
D1076	SDO error message (main index value)	NO	NO		R
D1077	SDO error message (secondary index value)	NO	NO		R
D1078	SDO error message (error code)	NO	NO		R
D1079	SDO error message (error code)	NO	NO		R
D1080	Reserved	-	-		-
D1081 – D1086	Reserved	-	-		-
D1087 – D1089	Reserved	-	-		-
D1090	Synchronizing cycle setting	NO	YES	4	RW
D1091	Sets slave station On or Off (bit 0–bit 7 correspond to slave stations number 0–7)	NO	YES	FFFFH	RW
D1092	Delay before start of initialization	NO	YES	0	RW
D1093	Break time detection	NO	YES	1000ms	RW
D1094	Break number detection	NO	YES	3	RW
D1095 – D1096	Reserved	-	-		-
D1097	Corresponding real-time transmission type (PDO) Setting range: 1–240	NO	YES	1	RW
D1098	Corresponding real-time receiving type (PDO) Setting range: 1–240	NO	YES	1	RW
D1099	Initialization completion delay time Setting range: 1–60000 sec.	NO	YES	15 sec.	RW
D2000+100*n	Station number n of slave station Setting range: 0–127 0: No CANopen function	NO	YES	0	RW

The C2000 supports 8 slave stations under the CANopen protocol; each slave station occupies 100 special D locations; stations are numbered 1–8, total of 8 stations.

Explanation of slave station number	Slave station no. 1	D2000 D2001 – D2099	Node ID Slave station no. 1 torque restrictions – Address 4(H) corresponding to receiving channel 4
	Slave station no. 2	D2100 D2101 – D2199	Node ID Slave station no. 2 torque restrictions – Address 4(H) corresponding to receiving channel 4
	Slave station no. 3	D2200 D2201 – D2299	Node ID Slave station no. 3 torque restrictions – Address 4(H) corresponding to receiving channel 4
		↓	
	Slave station no. 8	D2700 D2701 – D2799	Node ID Slave station no. 8 torque restrictions – Address 4(H) corresponding to receiving channel 4

- The range of n is 0–7
- Indicates PDOTX, ▲ Indicates PDORX; unmarked special D can be refreshed using the CANFLS command

Special D	Description of Function	Default:	R/W
D2000+100*n	Station number n of slave station Setting range: 0–127 0: No CANopen function	0	RW
D2002+100*n	Manufacturer code of slave station number n (L)	0	R
D2003+100*n	Manufacturer code of slave station number n (H)	0	R
D2004+100*n	Manufacturer's product code of slave station number n (L)	0	R
D2005+100*n	Manufacturer's product code of slave station number n (H)	0	R

Basic definitions

Special D	Description of Function	Default:	CAN Index	PDO Default:				R/W
				1	2	3	4	
D2006+100*n	Communications break handling method of slave station number n	0	6007H–0010H					RW
D2007+100*n	Error code of slave station number n error	0	603FH–0010H					R
D2008+100*n	Control word of slave station number n	0	6040H–0010H	●		●	●	RW
D2009+100*n	Status word of slave station number n	0	6041H–0010H	▲		▲	▲	R
D2010+100*n	Control mode of slave station number n	2	6060H–0008H					RW
D2011+100*n	Actual mode of slave station number n	2	6061H–0008H					R

Velocity Control

Slave station number n=0–7

Special D	Description of Function	Default:	CAN Index	PDO Default:				R/W
				1	2	3	4	
D2001+100*n	Torque restriction on slave station number n	0	6072H–0010H					RW
D2012+100*n	Target speed of slave station number n	0	6042H–0010H	●				RW
D2013+100*n	Actual speed of slave station number n	0	6043H–0010H	▲				R
D2014+100*n	Error speed of slave station number n	0	6044H–0010H					R
D2015+100*n	Acceleration time of slave station number n	1000	604FH–0020H					R
D2016+100*n	Deceleration time of slave station number n	1000	6050H–0020H					RW

## Torque control

Slave station number n=0–7

Special D	Description of Function	Default:	CAN Index	PDO Default:				R/W
				1	2	3	4	
D2017+100*n	Target torque of slave station number n	0	6071H–0010H				●	RW
D2018+100*n	Actual torque of slave station number n	0	6077H–0010H				▲	R
D2019+100*n	Actual current of slave station number n	0	6078H–0010H					R

## Position control

Slave station number n=0–7

Special D	Description of Function	Default:	CAN Index	PDO Default:				R/W
				1	2	3	4	
D2020+100*n	Target of slave station number n (L)	0	607AH–0020H			●		RW
D2021+100*n	Target of slave station number n (H)	0						RW
D2022+100*n	Actual position of slave station number n (L)	0	6064H–0020H				▲	R
D2023+100*n	Actual position of slave station number n (H)	0						R
D2024+100*n	Speed chart of slave station number n (L)	10000	6081H–0020H					RW
D2025+100*n	Speed chart of slave station number n (H)	0						RW

## 20XXH correspondences: MI MO AI AO

Slave station number n=0–7

Special D	Description of Function	Default:	CAN Index	PDO Default:				R/W
				1	2	3	4	
D2026+100*n	MI status of slave station number n	0	2026H–0110H		▲			RW
D2027+100*n	MO setting of slave station number n	0	2026H–4110H		●			RW
D2028+100*n	AI1 status of slave station number n	0	2026H–6110H		▲			RW
D2029+100*n	AI2 status of slave station number n	0	2026H–6210H		▲			RW
D2030+100*n	AI3 status of slave station number n	0	2026H–6310H		▲			RW
D2031+100*n	AO1 status of slave station number n	0	2026H–A110H		●			RW
D2032+100*n	AO2 status of slave station number n	0	2026H–A210H		●			RW
D2033+100*n	AO3 status of slave station number n	0	2026H–A310H		●			RW

## PDO reflection length setting:

Special D	Description of Function	Default:	R/W
D2034+100*n	Real-time transmission setting of slave station number n	000AH	RW
D2067+100*n	Real-time reception setting of slave station number n	0000H	RW

## 16-5-4 PLC Communication address

Device	Range	Type	Address (Hex)
X	00–37 (Octal)	bit	0400–041F
Y	00–37 (Octal)	bit	0500–051F
T	00–159	bit/word	0600–069F
M	000–799	bit	0800–0B1F
M	1000–1079	bit	0BE8–0C37
C	0–79	bit/word	0E00–0E47
D	00–399	word	1000–118F
D	1000–1099	word	13E8–144B
D	2000–2799	word	17D0–1AEF

Command code that can be used

Function Code	Description of Function	Function target
01	Coil status read	Y,M,T,C
02	Input status read	X,Y,M,T,C
03	Read single unit of data	T,C,D
05	Compulsory single coil status change	Y,M,T,C
06	Write single unit of data	T,C,D
0F	Compulsory multiple coil status change	Y,M,T,C
10	Write multiple units of data	T,C,D

 **NOTE**

When PLC functions have been activated, the C2000 can match PLC and drive parameters; this method employs different addresses, drives (default station number is 1, PLC sets station number as 2)

## 16-6 Introduction to the Command Window

### 16-6-1 Overview of basic commands

#### Ordinary commands

Command code	Function	OPERAND	Execution speed (us)
LD	Load contact a	X, Y, M, T, C	0.8
LDI	Load contact b	X, Y, M, T, C	0.8
AND	Connect contact a in series	X, Y, M, T, C	0.8
ANI	Connect contact b in series	X, Y, M, T, C	0.8
OR	Connect contact a in parallel	X, Y, M, T, C	0.8
ORI	Connect contact b in parallel	X, Y, M, T, C	0.8
ANB	Series circuit block	N/A	0.3
ORB	Parallel circuit block	N/A	0.3
MPS	Save to stack	N/A	0.3
MRD	Stack read (pointer does not change)	N/A	0.3
MPP	Read stack	N/A	0.3

#### Output command

Command code	Function	OPERAND	Execution speed (us)
OUT	Drive coil	Y, M	1
SET	Action continues (ON)	Y, M	1
RST	Clear contact or register	Y, M, T, C, D	1.2

#### Timer, counter

Command code	Function	OPERAND	Execution speed (us)
TMR	16-bit timer	T-K or T-D commands	1.1
CNT	16-bit counter	C-K or C-D (16-bit)	0.5

#### Main control command

Command code	Function	OPERAND	Execution speed (us)
MC	Common series contact connection	N0-N7	0.4
MCR	Common series contact release	N0-N7	0.4

#### Contact rising edge / falling edge detection command

Command code	Function	OPERAND	Execution speed (us)
LDP	Start of forward edge detection action	X, Y, M, T, C	1.1
LDF	Start of reverse edge detection action	X, Y, M, T, C	1.1
ANDP	Forward edge detection series connection	X, Y, M, T, C	1.1
ANDF	Reverse edge detection series connection	X, Y, M, T, C	1.1
ORP	Forward edge detection parallel connection	X, Y, M, T, C	1.1
ORF	Reverse edge detection parallel connection	X, Y, M, T, C	1.1

#### Upper/lower differential output commands

Command code	Function	OPERAND	Execution speed (us)
PLS	Upper differential output	Y, M	1.2
PLF	Lower differential output	Y, M	1.2

### Stop command

Command code	Function	OPERAND	Execution speed (us)
END	Program conclusion	N/A	0.2

### Other commands

Command code	Function	OPERAND	Execution speed (us)
NOP	No action	N/A	0.2
INV	Inverse of operation results	N/A	0.2
P	Index	P	0.3

## 16-6-2 Detailed explanation of basic commands

Command	Function					
<b>LD</b>	Load contact a					
Operand	X0–X17	Y0–Y17	M0–M799	T0–159	C0–C79	D0–D399
	✓	✓	✓	✓	✓	–

**Explanation** The LD command is used for contact a starting at the left busbar or contact a starting at a contact circuit block; its function is to save current content and save the acquired contact status in the cumulative register.

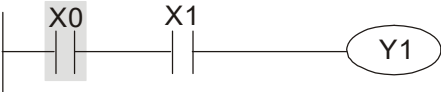
**Example** Ladder diagram: 

Command code:	Description:
<b>LD</b> X0	Load Contact a of X0
AND X1	Create series connection to contact a of X1
OUT Y1	Drive Y1 coil

Command	Function					
<b>LDI</b>	Load contact b					
Operand	X0–X17	Y0–Y17	M0–M799	T0–159	C0–C79	D0–D399
	✓	✓	✓	✓	✓	–

**Explanation** The LDI command is used for contact b starting at the left busbar or contact b starting at a contact circuit block; its function is to save current content and save the acquired contact status in the cumulative register.

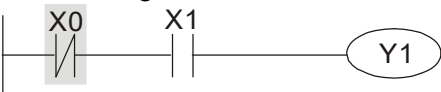
**Example** Ladder diagram: 

Command code:	Description:
<b>LDI</b> X0	Load Contact b of X0
AND X1	Create series connection to contact a of X1
OUT Y1	Drive Y1 coil

Command	Function					
<b>AND</b>	Connect contact a in series					
Operand	X0–X17	Y0–Y17	M0–M799	T0–159	C0–C79	D0–D399
	✓	✓	✓	✓	✓	–

**Explanation** The AND command is used to create a series connection to contact a; first reads current status of the designated series contact and logical operation results before contact in order to perform "AND" operation; saves results in cumulative register.

**Example** Ladder diagram: 

Command code:	Description:
LDI X1	Load Contact b of X1
<b>AND</b> X0	Create series connection to contact a of X0
OUT Y1	Drive Y1 coil

Command	Function					
<b>ANI</b>	Connect contact b in series					
Operand	X0-X17	Y0-Y17	M0-M799	T0-159	C0-C79	D0-D399
	✓	✓	✓	✓	✓	—

**Explanation** The ANI command is used to create a series connection to contact b; its function is to first read current status of the designated series contact and logical operation results before contact in order to perform "AND" operation; saves results in cumulative register.

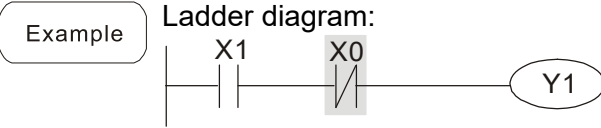

Command code:	Description:
LD X1	Load Contact a of X1
<b>ANI X0</b>	Create series connection to contact b of X0
OUT Y1	Drive Y1 coil

Command	Function					
<b>OR</b>	Connect contact a in parallel					
Operand	X0-X17	Y0-Y17	M0-M799	T0-159	C0-C79	D0-D399
	✓	✓	✓	✓	✓	—

**Explanation** The OR command is used to establish a parallel connection to contact a; its function is to first read current status of the designated series contact and logical operation results before contact in order to perform "OR" operation; saves results in cumulative register.

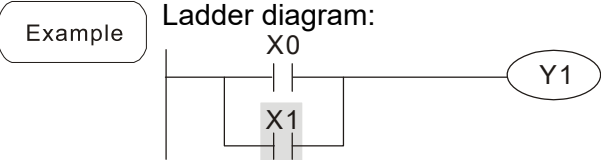

Command code:	Description:
LD X0	Load Contact a of X0
<b>OR X1</b>	Create series connection to contact a of X1
OUT Y1	Drive Y1 coil

Command	Function					
<b>ORI</b>	Connect contact b in parallel					
Operand	X0-X17	Y0-Y17	M0-M799	T0-159	C0-C79	D0-D399
	✓	✓	✓	✓	✓	—

**Explanation** The ORI command is used to establish a parallel connection to contact a; its function is to first read current status of the designated series contact and logical operation results before contact in order to perform "OR" operation; saves results in cumulative register.

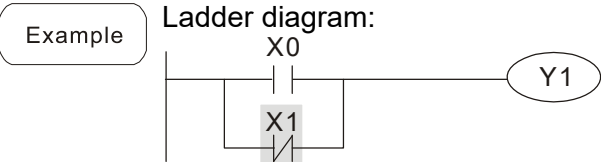

Command code:	Description:
LD X0	Load Contact a of X0
<b>ORI X1</b>	Create series connection to contact b of X1
OUT Y1	Drive Y1 coil

Command	Function					
<b>ANB</b>	Series circuit block					
Operand	N/A					

**Explanation** ANB performs an "AND" operation on the previously saved logic results and the current cumulative register content.

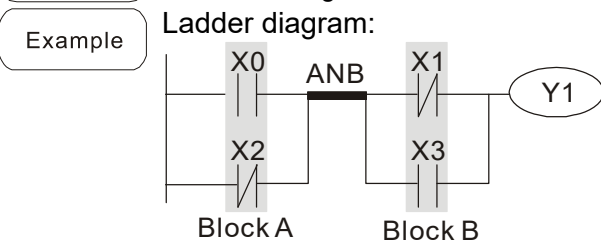

Command code:	Description:
LD X0	Load Contact a of X0
ORI X2	Establish parallel connection to contact b of X2
LDI X1	Load Contact b of X1
OR X3	Establish parallel connection to contact a of X3
<b>ANB</b>	Series circuit block
OUT Y1	Drive Y1 coil



Command	Function
<b>ORB</b>	Parallel circuit block
Operand	N/A

**Explanation** ORB performs an "OR" operation on the previously saved logic results and the current cumulative register content.

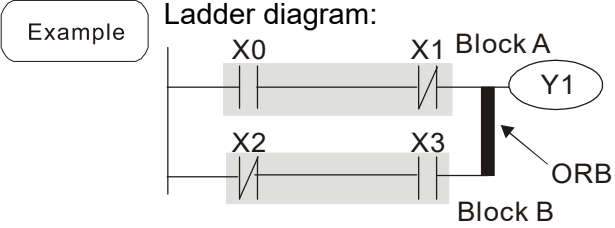

Command code:	Description:
LD X0	Load Contact a of X0
ANI X1	Establish parallel connection to contact b of X1
LDI X2	Load Contact b of X2
AND X3	Establish parallel connection to contact a of X3
<b>ORB</b>	<b>Parallel circuit block</b>
OUT Y1	Drive Y1 coil

Command	Function
<b>MPS</b>	Save to stack
Operand	N/A

**Explanation** Save current content of cumulative register to the stack. (Add one to stack pointer)

Command	Function
<b>MRD</b>	Read stack (pointer does not change)
Operand	N/A

**Explanation** Reads stack content and saves to cumulative register. (Stack pointer does not change)

Command	Function
<b>MPP</b>	Read stack
Operand	N/A

**Explanation** Retrieves result of previously-save logical operation from the stack, and saves to cumulative register. (Subtract one from stack pointer)

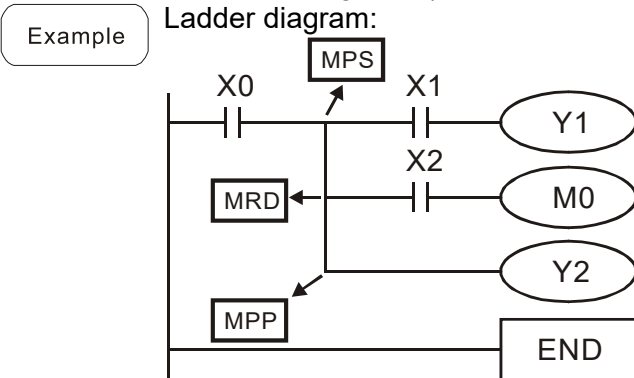

Command code:	Description:
LD X0	Load Contact a of X0
<b>MPS</b>	<b>Save to stack</b>
AND X1	Create series connection to contact a of X1
OUT Y1	Drive Y1 coil
<b>MRD</b>	<b>Read stack (pointer does not change)</b>
AND X2	Create series connection to contact a of X2
OUT M0	Drive M0 coil
<b>MPP</b>	<b>Read stack</b>
OUT Y2	Drive Y2 coil
END	Program conclusion

Command	Function					
<b>OUT</b>	Drive coil					
Operand	X0–X17	Y0–Y17	M0–M799	T0–159	C0–C79	D0–D399
	–	✓	✓	–	–	–

Explanation Outputs result of logical operation before OUT command to the designated element.  
Coil contact action:

Result:	Out command		
	Coil	Access Point:	
		Contact a (NO)	Contact b (NC)
FALSE	Off	Not conducting	Conducting
TRUE	On	Conducting	Not conducting

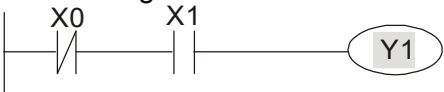
Example Ladder diagram:  Command code: LD X0 Description: Load Contact b of X0  
AND X1 description: Establish parallel connection to contact a of X1  
**OUT Y1** Drive Y1 coil

Command	Function					
<b>SET</b>	Action continues (ON)					
Operand	X0–X17	Y0–Y17	M0–M799	T0–159	C0–C79	D0–D399
	–	✓	✓	–	–	–

Explanation When the SET command is driven, the designated element will be set as On, and will be maintained in an On state, regardless of whether the SET command is still driven. The RST command can be used to set the element as Off.

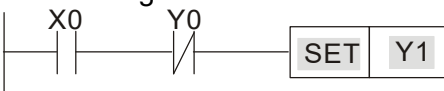
Example Ladder diagram:  Command code: LD X0 Description: Load Contact a of X0  
AN Y0 description: Establish parallel connection to contact b of Y0  
**SET Y1** Action continues (ON)

Command	Function					
<b>RST</b>	Clear contact or register					
Operand	X0–X17	Y0–Y17	M0–M799	T0–159	C0–C79	D0–D399
	–	✓	✓	✓	✓	✓

Explanation When the RST command is driven, the action of the designated element will be as follows:

Element	Mode
Y, M	Both coil and contact will be set as Off.
T, C	The current timing or count value will be set as 0, and both the coil and contact will be set as Off.
D	The content value will be set as 0.

If the RST command has not been executed, the status of the designated element will remain unchanged.

Example Ladder diagram:  Command code: LD X0 Description: Load Contact a of X0  
**RST Y5** Clear contact or register

Command	Function	
<b>TMR</b>	16-bit timer	
Operand	T-K	T0–T159, K0–K32,767
	T-D	T0–T159, D0–D399

**Explanation** When the TMR command is executed, the designated timer coil will be electrified, and the timer will begin timing. The contact's action will be as follows when the timing value reaches the designated set value (timing value  $\geq$  set value):

NO (Normally Open) contact	Closed
NC (Normally Close) contact	Open

If the RST command has not been executed, the status of the designated element will remain unchanged.

**Example** Ladder diagram: Command code:      Description:

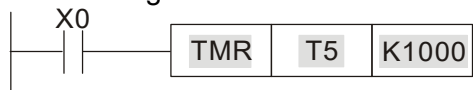

LD	X0	Load Contact a of X0
<b>TMR</b>	<b>T5 K1000</b>	T5 timer Set value as K1000

Command	Function	
<b>CNT</b>	16-bit counter	
Operand	C-K	C0–C79, K0–K32,767
	C-D	C0–C79, D0–D399

**Explanation** When the CNT command is executed from Off→On, this indicates that the designated counter coil goes from no power → electrified, and 1 will be added to the counter's count value; when the count reaches the designated value (count value = set value), the contact will have the following action:

NO (Normally Open) contact	Closed
NC (Normally Close) contact	Open

After the count value has been reached, the contact and count value will both remain unchanged even if there is continued count pulse input. Please use the RST command if you wish to restart or clear the count.

**Example** Ladder diagram: Command code:      Description:

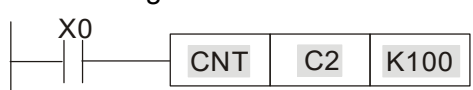

LD	X0	Load Contact a of X0
<b>CNT</b>	<b>C2 K100</b>	C2counter Set value as K100

Command	Function	
<b>MC/MCR</b>	Connect/release a common series contact	
Operand	N0–N7	

**Explanation** MC is the main control initiation command, and any commands between MC and MCR will be executed normally. When the MC command is Off, any commands between MC and MCR will act as follows:

Determination of commands	Description
Ordinary timer	The timing value will revert to 0, the coil will lose power, and the contact will not operate
Counter	The coil will lose power, and the count value and contact will stay in their current state
Coil driven by OUT command	None receive power
Elements driven by SET, RST commands	Will remain in their current state
Applications commands	None are actuated

MCR is the main control stop command, and is placed at the end of the main control program. There may not be any contact commands before the MCR command.

The MC-MCR main control program commands support a nested program structure with a maximum only 8 levels; use in the order N0–N7, please refer to the following program:

Example

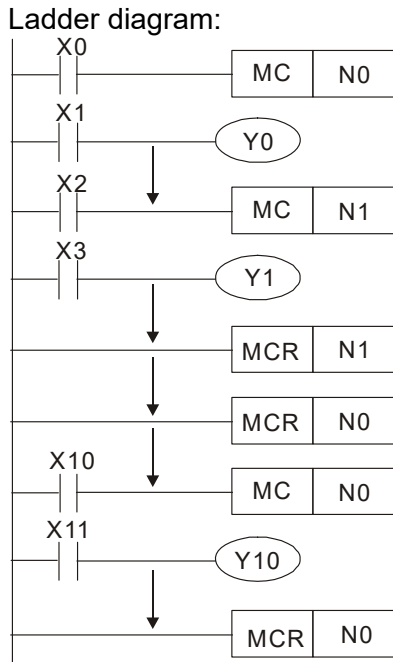

Command code:	Description:
LD X0	Load Contact a of X0
<b>MC N0</b>	Connection of N0 common series contact
LD X1	Load Contact a of X1
OUT Y0	Drive Y0 coil
:	
LD X2	Load Contact a of X2
<b>MC N1</b>	Connection of N1 common series contact
LD X3	Load Contact a of X3
OUT Y1	Drive Y1 coil
:	
<b>MCR N1</b>	Release N1 common series contact
:	
<b>MCR N0</b>	Release N0 common series contact
:	
LD X10	Load Contact a of X10
<b>MC N0</b>	Connection of N0 common series contact
LD X11	Load Contact a of X11
OUT Y10	Drive Y10 coil
:	
<b>MCR N0</b>	Release N0 common series contact

Command	Function					
<b>LDP</b>	Start of forward edge detection action					
Operand	X0–X17	Y0–Y17	M0–M799	T0–159	C0–C79	D0–D399
	✓	✓	✓	✓	✓	–

Explanation The LDP command has the same usage as LD, but its action is different; its function is to save current content, while also saving the detected state of the rising edge of the contact to the cumulative register.

Example

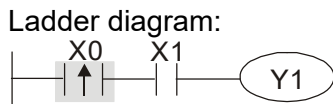

Command code:	Description:
<b>LDP X0</b>	Start of X0 forward edge detection action
<b>AND X1</b>	Create series connection to contact a of X1
OUT Y1	Drive Y1 coil

Remark

Please refer to the function specifications table for each device in series for the scope of usage of each operand.  
A rising edge contact will be TRUE after power is turned on if the rising edge contact is On before power is turned on to the PLC.

Command	Function					
<b>LDF</b>	Start of reverse edge detection action					
Operand	X0–X17	Y0–Y17	M0–M799	T0–159	C0–C79	D0–D399
	✓	✓	✓	✓	✓	–

Explanation The LDF command has the same usage as LD, but its action is different; its function is to save current content while also saving the detected state of the falling edge of the contact to the cumulative register.

Example

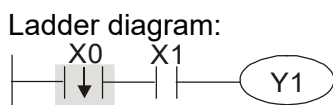

Command code:	Description:
<b>LDF X0</b>	Start of X0 reverse edge detection action
<b>AND X1</b>	Create series connection to contact a of X1
OUT Y1	Drive Y1 coil

Command	Function					
<b>ANDP</b>	Forward edge detection series connection					
Operand	X0–X17	Y0–Y17	M0–M799	T0–159	C0–C79	D0–D399
	✓	✓	✓	✓	✓	–

**Explanation** The ANDP command used for a contact rising edge detection series connection.

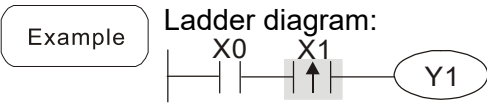

Command code:	Description:
LD X0	Load Contact a of X0
<b>ANDP X1</b>	<b>X1 Forward edge detection series connection</b>
OUT Y1	Drive Y1 coil

Command	Function					
<b>ANDF</b>	Reverse edge detection series connection					
Operand	X0–X17	Y0–Y17	M0–M799	T0–159	C0–C79	D0–D399
	✓	✓	✓	✓	✓	–

**Explanation** The ANDF command is used for a contact falling edge detection series connection.

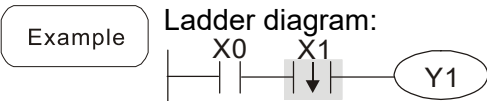

Command code:	Description:
LD X0	Load Contact a of X0
<b>ANDF X1</b>	<b>X1 Reverse edge detection series connection</b>
OUT Y1	Drive Y1 coil

Command	Function					
<b>ORP</b>	Forward edge detection parallel connection					
Operand	X0–X17	Y0–Y17	M0–M799	T0–159	C0–C79	D0–D399
	✓	✓	✓	✓	✓	–

**Explanation** The ORP command is used for a contact rising edge detection parallel connection.

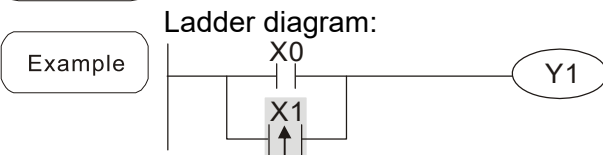

Command code:	Description:
LD X0	Load Contact a of X0
<b>ORP X1</b>	<b>X1 Forward edge detection parallel connection</b>
OUT Y1	Drive Y1 coil

Command	Function					
<b>ORF</b>	Reverse edge detection parallel connection					
Operand	X0–X17	Y0–Y17	M0–M799	T0–159	C0–C79	D0–D399
	✓	✓	✓	✓	✓	–

**Explanation** The ORF command is used for contact falling edge detection parallel connection.

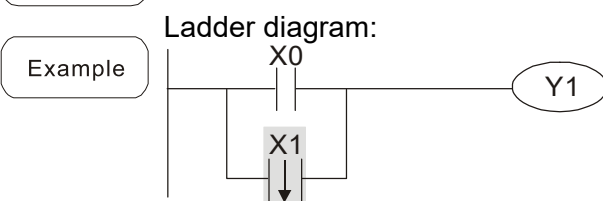

Command code:	Description:
LD X0	Load Contact a of X0
<b>ORF X1</b>	<b>X1 Reverse edge detection parallel connection</b>
OUT Y1	Drive Y1 coil

Command	Function					
<b>PLS</b>	Upper differential output					
Operand	X0–X17	Y0–Y17	M0–M799	T0–159	C0–C79	D0–D399
	–	✓	✓	–	–	–

Explanation

Upper differential output commands. When X0=Off→On (positive edge-triggered), the PLS command will be executed, and M0 will send one pulse, with a pulse length consisting of one scanning period.

Example

Ladder diagram:

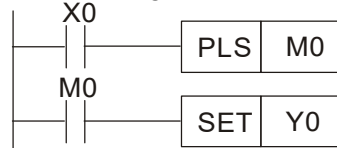

Time sequence diagram:

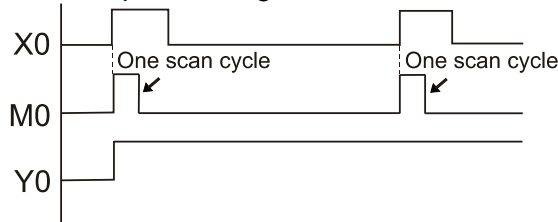

Command code:

Description:

LD	X0	Load Contact a of X0
PLS	<b>M0</b>	M0 Upper differential output
LD	M0	Load Contact a of M0
SET	Y0	Y0 Action continues (ON)

Command	Function					
<b>PLF</b>	Lower differential output					
Operand	X0–X17	Y0–Y17	M0–M799	T0–159	C0–C79	D0–D399
	–	✓	✓	–	–	–

Explanation

Lower differential output command. When X0= On→Off (negative edge-triggered), the PLF command will be executed, and M0 will send one pulse, with pulse length consisting of one scanning period.

Example

Ladder diagram:

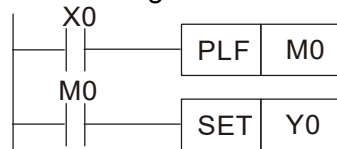

Time sequence diagram:

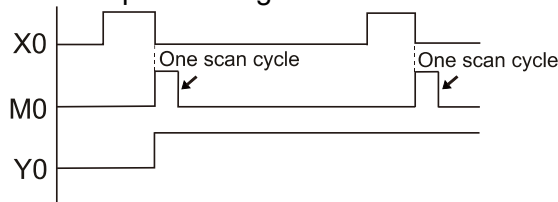

Command code:

Description:

LD	X0	Load Contact a of X0
PLF	<b>M0</b>	M0 Lower differential output
LD	M0	Load Contact a of M0
SET	Y0	Y0 Action continues (ON)

Command	Function
<b>END</b>	Program conclusion
Operand	N/A

Explanation

An END command must be added to the end of a ladder diagram program or command program. The PLC will scan from address 0 to the END command, and will return to address 0 and begins scanning again after execution.

Command	Function
<b>NOP</b>	No action
Operand	N/A

Explanation

The command NOP does not perform any operation in the program. Because execution of this command will retain the original logical operation results, it can be used in the following situation: the NOP command can be used instead of a command that is deleted without changing the program length.

Example

Ladder diagram:

NOP command will be simplified and not displayed when the ladder diagram is displayed.

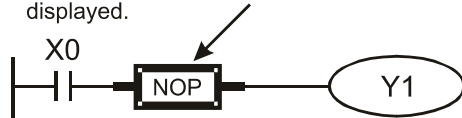

Command code:

Description:

LD	X0	Load Contact b of X0
<b>NOP</b>		No action
OUT	Y1	Drive Y1 coil

Command	Function
<b>INV</b>	Inverse of operation results
Operand	N/A

Explanation

Saves the result of the logic inversion operation prior to the INV command in the cumulative register.

Example

Ladder diagram:



Command code:

Description:

LD	X0	Load Contact a of X0
<b>INV</b>		Inverse of operation results
OUT	Y1	Drive Y1 coil

Command	Function
<b>P</b>	Index
Operand	P0–P255

Explanation

Pointer P is used to subprogram call command API 01 CALL. User does not require starting from zero, but the number cannot be used repeatedly, otherwise an unpredictable error will occur.

Example

Ladder diagram:

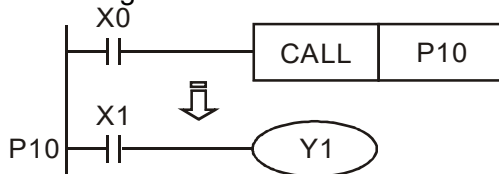

Command code:

Description:

LD	X0	Load Contact a of X0
CALL	P10	Call command CALL to P10
:		
<b>P10</b>		Pointer P10
LD	X1	Load Contact a of X1
OUT	Y1	Drive Y1 coil

## 16-6-3 Overview of application commands

Classification	API	Command code		P command	Function	STEPS	
		16 bit	32 bit			16 bit	32 bit
Circuit control	01	CALL	-	✓	Call subprogram	3	-
	2	SRET	-	-	Conclusion of subprogram	1	-
	06	FEND	-	-	Conclusion a main program	1	-
Send comparison	10	CMP	DCMP	✓	Compares set output	7	13
	11	ZCP	DZCP	✓	Range comparison	9	17
	12	MOV	DMOV	✓	Data movement	5	9
	13	SMOV	DSMOV	✓	Nibble movement	11	21
	15	BMOV	-	✓	Send all	7	-
Four logical operations	18	BCD	DBCD	✓	BIN to BCD transformation	5	9
	19	BIN	DBIN	✓	BCD to BIN transformation	5	9
	20	ADD	DADD	✓	BIN addition	7	13
	21	SUB	DSUB	✓	BIN subtraction	7	13
	22	MUL	DMUL	✓	BIN multiplication	7	13
	23	DIV	DDIV	✓	BIN division	7	13
	24	INC	DINC	✓	BIN add one	3	5
	25	DEC	DDEC	✓	BIN subtract one	3	5
Rotational displacement	30	ROR	DROR	✓	Right rotation	5	-
	31	ROL	DROL	✓	Left rotation	5	-
Data Process	40	ZRST	-	✓	Clear range	5	-
	41	DECO	DDECO	✓	Decoder	7	13
	42	ENCO	DENCO	✓	Encoder	7	13
	43	SUM	DSUM	✓	ON bit number	5	9
	44	BON	DBON	✓	ON bit judgement	7	13
	49	FLT	DFLT	✓	BIN whole number → binary floating point number transformation	5	9
Floating point operation	110	-	DECMP	✓	Comparison of binary floating point numbers	-	13
	111	-	DEZCP	✓	Comparison of binary floating point number range	-	17
	116	-	DRAD	✓	Angle → Diameter	-	9
	117	-	DDEG	✓	Diameter → angle	-	9
	120	-	DEADD	✓	Binary floating point number addition	-	13
	121	-	DESUB	✓	Binary floating point number subtraction	-	13
	122	-	DEMUL	✓	Binary floating point number multiplication	-	13
	123	-	DEDIV	✓	Binary floating point number division	-	13
	124	-	DEXP	✓	Binary floating point number obtain exponent	-	9
	125	-	DLN	✓	Binary floating point number obtain logarithm	-	9
	127	-	DESQR	✓	Binary floating point number find square root	-	9
	129	INT	DINT	✓	Binary floating point number → BIN whole number transformation	5	9
	130	-	DSIN	✓	Binary floating point number SIN operation	-	9
	131	-	DCOS	✓	Binary floating point number COS operation	-	9
	132	-	DTAN	✓	Binary floating point number TAN operation	-	9



Classification	API	Command code		P command	Function	STEPS	
		16 bit	32 bit			16 bit	32 bit
	133	–	DASIN	✓	Binary floating point number ASIN operation	–	9
	134	–	DACOS	✓	Binary floating point number ACOS operation	–	9
	135	–	DATAN	✓	Binary floating point number ATAN operation	–	9
	136	–	DSINH	✓	Binary floating point number SINH operation	–	9
	137	–	DCOSH	✓	Binary floating point number COSH operation	–	9
	138	–	DTANH	✓	Binary floating point number TANH operation	–	9
Other	147	SWAP	DSWAP	✓	Exchange the up/down 8 bits	3	5
communication	150	MODRW	–	✓	MODBUS read/write	7	–
Calendar	160	TCMP	–	✓	Compare calendar data	11	–
	161	TZCP	–	✓	Compare calendar data range	9	–
	162	TADD	–	✓	Calendar data addition	7	–
	163	TSUB	–	✓	Calendar data subtraction	7	–
	166	TRD	–	✓	Calendar data read	3	–
GRAY code	170	GRY	DGRY	✓	BIN→GRY code transformation	5	9
	171	GBIN	DGBIN	✓	GRY code →BIN transformation	5	9
Contact form logical operation	215	LD&	DLD&	-	Contact form logical operation LD#	5	9
	216	LD	DLD	-	Contact form logical operation LD#	5	9
	217	LD^	DLD^	-	Contact form logical operation LD#	5	9
	218	AND&	DAND&	-	Contact form logical operation AND#	5	9
	219	ANDI	DANDI	-	Contact form logical operation AND#	5	9
	220	AND^	DAND^	-	Contact form logical operation AND#	5	9
	221	OR&	DOR&	-	Contact form logical operation OR#	5	9
	222	OR	DOR	-	Contact form logical operation OR#	5	9
	223	OR^	DOR^	-	Contact form logical operation OR#	5	9
Contact form compare command	224	LD=	DLD=	-	Contact form compare LD*	5	9
	225	LD>	DLD>	-	Contact form compare LD*	5	9
	226	LD<	DLD<	-	Contact form compare LD*	5	9
	228	LD<>	DLD<>	-	Contact form compare LD*	5	9
	229	LD<=	DLD<=	-	Contact form compare LD*	5	9
	230	LD>=	DLD>=	-	Contact form compare LD*	5	9
	232	AND=	DAND=	-	Contact form compare AND*	5	9
	233	AND>	DAND>	-	Contact form compare AND*	5	9
	234	AND<	DAND<	-	Contact form compare AND*	5	9
	236	AND<>	DAND<>	-	Contact form compare AND*	5	9
	237	AND<=	DAND<=	-	Contact form compare AND*	5	9
	238	AND>=	DAND>=	-	Contact form compare AND*	5	9
	240	OR=	DOR=	-	Contact form compare OR*	5	9
	241	OR>	DOR>	-	Contact form compare OR*	5	9
242	OR<	DOR<	-	Contact form compare OR*	5	9	
244	OR<>	DOR<>	-	Contact form compare OR*	5	9	
245	OR<=	DOR<=	-	Contact form compare OR*	5	9	
246	OR>=	DOR>=	-	Contact form compare OR*	5	9	

Classification	API	Command code		P command	Function	STEPS	
		16 bit	32 bit			16 bit	32 bit
Floating point contact form	275	-	FLD=	-	Floating point number contact form compare LD*	-	9
	276	-	FLD>	-	Floating point number contact form compare LD*	-	9
	277	-	FLD<	-	Floating point number contact form compare LD*	-	9
Compare command	278	-	FLD<>	-	Floating point number contact form compare LD*	-	9
	279	-	FLD<=	-	Floating point number contact form compare LD*	-	9
	280	-	FLD>=	-	Floating point number contact form compare LD*	-	9
	281	-	FAND=	-	Floating point number contact form compare AND*	-	9
	282	-	FAND>	-	Floating point number contact form compare AND*	-	9
	283	-	FAND<	-	Floating point number contact form compare AND*	-	9
	284	-	FAND<>	-	Floating point number contact form compare AND*	-	9
	285	-	FAND<=	-	Floating point number contact form compare AND*	-	9
	286	-	FAND>=	-	Floating point number contact form compare AND*	-	9
	287	-	FOR=	-	Floating point number contact form compare OR*	-	9
	288	-	FOR>	-	Floating point number contact form compare OR*	-	9
	289	-	FOR<	-	Floating point number contact form compare OR*	-	9
	290	-	FOR<>	-	Floating point number contact form compare OR*	-	9
	291	-	FOR<=	-	Floating point number contact form compare OR*	-	9
	292	-	FOR>=	-	Floating point number contact form compare OR*	-	9
Drive special command	139	RPR	-	✓	Read servo parameter	5	-
	140	WPR	-	✓	Write servo parameter	5	-
	141	FPID	-	✓	Drive PID control mode	9	-
	142	FREQ	-	✓	Drive torque control mode	7	-
	262	-	DPOS	✓	Set target	-	5
	263	TORQ	-	✓	Set target torque	5	-
	261	CANRX	-	✓	Read CANopen slave station data	9	-
	264	CANTX	-	✓	Write CANopen slave station data	9	-
	265	CANFLS	-	✓	Refresh special D corresponding to CANopen	3	-
	320	ICOMR	DICOMR	✓	Internal communications read	9	17
321	ICOMW	DICOMW	✓	Internal communications write	9	17	
323	WPRA	-	-	RAM write in drive parameters	5	-	

### 16-6-4 Detailed explanation of applications commands

API 01	<b>CALL</b>	P	( S )	Call subprogram																																																	
<table border="1"> <thead> <tr> <th colspan="3">Bit device</th> <th colspan="8">Word device</th> </tr> <tr> <th>X</th><th>Y</th><th>M</th> <th>K</th><th>H</th><th>KnX</th><th>KnY</th><th>KnM</th><th>T</th><th>C</th><th>D</th> </tr> </thead> <tbody> <tr> <td colspan="3"></td> <td colspan="8">Notes on operand usage: The S operand can designate P C2000 series device: The S operand can designate P0-P63</td> </tr> </tbody> </table>			Bit device			Word device								X	Y	M	K	H	KnX	KnY	KnM	T	C	D				Notes on operand usage: The S operand can designate P C2000 series device: The S operand can designate P0-P63								<table border="1"> <thead> <tr> <th colspan="4">16-bit command (3 STEP)</th> </tr> </thead> <tbody> <tr> <td>CALL</td> <td>Continuous execution type</td> <td>CALLP</td> <td>Pulse execution type</td> </tr> <tr> <th colspan="4">32-bit command</th> </tr> <tr> <td>—</td><td>—</td><td>—</td><td>—</td> </tr> </tbody> </table>		16-bit command (3 STEP)				CALL	Continuous execution type	CALLP	Pulse execution type	32-bit command				—	—	—	—
Bit device			Word device																																																		
X	Y	M	K	H	KnX	KnY	KnM	T	C	D																																											
			Notes on operand usage: The S operand can designate P C2000 series device: The S operand can designate P0-P63																																																		
16-bit command (3 STEP)																																																					
CALL	Continuous execution type	CALLP	Pulse execution type																																																		
32-bit command																																																					
—	—	—	—																																																		
				Flag signal: none																																																	

Explanation

- **S** : Call subprogram pointer.
- Write the subprogram after the FEND command.
- The subprogram must end after the SRET command.
- Refer to the FEND command explanation and sample content for detailed command functions.

API 02	<b>SRET</b>	P	—	Conclusion of subprogram																																																	
<table border="1"> <thead> <tr> <th colspan="3">Bit device</th> <th colspan="8">Word device</th> </tr> <tr> <th>X</th><th>Y</th><th>M</th> <th>K</th><th>H</th><th>KnX</th><th>KnY</th><th>KnM</th><th>T</th><th>C</th><th>D</th> </tr> </thead> <tbody> <tr> <td colspan="3"></td> <td colspan="8">Notes on operand usage: No operand A contact-driven command is not needed</td> </tr> </tbody> </table>			Bit device			Word device								X	Y	M	K	H	KnX	KnY	KnM	T	C	D				Notes on operand usage: No operand A contact-driven command is not needed								<table border="1"> <thead> <tr> <th colspan="4">16-bit command (1 STEP)</th> </tr> </thead> <tbody> <tr> <td>FEND</td> <td>Continuous execution type</td> <td>—</td> <td>—</td> </tr> <tr> <th colspan="4">32-bit command</th> </tr> <tr> <td>—</td><td>—</td><td>—</td><td>—</td> </tr> </tbody> </table>		16-bit command (1 STEP)				FEND	Continuous execution type	—	—	32-bit command				—	—	—	—
Bit device			Word device																																																		
X	Y	M	K	H	KnX	KnY	KnM	T	C	D																																											
			Notes on operand usage: No operand A contact-driven command is not needed																																																		
16-bit command (1 STEP)																																																					
FEND	Continuous execution type	—	—																																																		
32-bit command																																																					
—	—	—	—																																																		
				Flag signal: none																																																	

Explanation

- A contact-driven command is not needed. Automatically returns next command after CALL command
- Indicates end of subprogram. After end of subprogram, SRET returns to main program, and executes next command after the original call subprogram CALL command.
- Refer to the FEND command explanation and sample content for detailed command functions.

API 06	<b>FEND</b>	—	Conclusion a main program
-----------	-------------	---	---------------------------

	Bit device			Word device							16-bit command (1 STEP)				
	X	Y	M	K	H	KnX	KnY	KnM	T	C	D	FEND	Continuous execution type	—	—
Notes on operand usage: No operand A contact-driven command is not needed												32-bit command			
												Flag signal: none			

Explanation

- This command indicates the end of the main program. It is the same as the END command when the PLC executes this command.
- The CALL command program must be written after the FEND command, and the SRET command added to the end of the subprogram.
- When using the FEND command, an END command is also needed. However, the END command must be placed at the end, after the main program and subprogram.

CALL command process

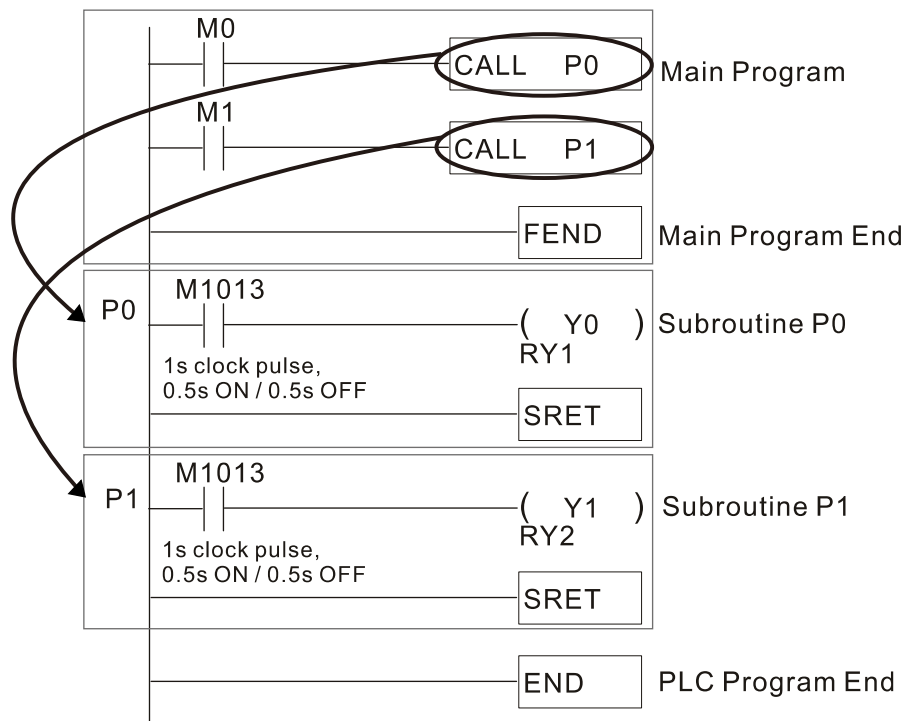

API 10	D	<b>CMP</b>	P	(S1)	(S2)	(D)	Compares set output							
Bit device			Word device								16-bit command (7 STEP)			
X	Y	M	K	H	KnX	KnY	KnM	T	C	D	CMP	Continuous execution type	CMPP	Pulse execution type
S1			*	*	*	*	*	*	*	*				
S2			*	*	*	*	*	*	*	*				
D		*	*											
Notes on operand usage: The operand D occupies three consecutive points											32-bit command (13 STEP)			
											DCMP	Continuous execution type	DCMPP	Pulse execution type
											Flag signal: none			

- Explanation**
- (S1): Compare value 1. (S2): Compare value 2. (D): Results of comparison.
  - Compares the size of the content of operand (S1) and (S2); the results of comparison are expressed in (D).
  - Size comparison is performed algebraically. All data is compared in the form of numerical binary values. Because this is a 16-bit command, when b15 is 1, this indicates a negative number.

- Example**
- When the designated device is Y0, it automatically occupies Y0, Y1 and Y2.
  - When X10=On, the CMP command executes, and Y0, Y1 or Y2 will be On. When X10=Off, the CMP command will not execute, and the state of Y0, Y1 and Y2 will remain in the state prior to X10=Off.
  - If ≥, ≤, or ≠ results are needed, they can be obtained via series/parallel connections of Y0–Y2.

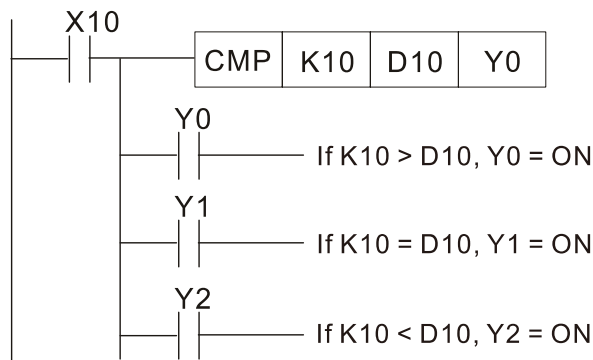

- To clear results of comparison, use the RST or ZRST command.

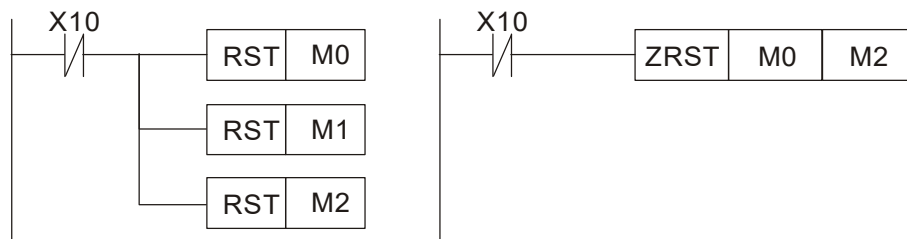

API 11	D	ZCP	P	(S1)	(S2)	(S)	(D)	Range comparison							
Bit device		Word device										16-bit command (9 STEP)			
X	Y	M	K	H	KnX	KnY	KnM	T	C	D	ZCP	Continuous execution type	ZCPP	Pulse execution type	
S1			*	*	*	*	*	*	*	*					
S2			*	*	*	*	*	*	*	*					
S			*	*	*	*	*	*	*	*					
D		*	*												
Notes on operand usage: The content value of operand S1 is less than the content value of S2 operand The operand D occupies three consecutive points											32-bit command (17 STEP)				
											DZCP	Continuous execution type	DZCPP	Pulse execution type	
											Flag signal: none				

Explanation

- (S1): Lower limit of range comparison. (S2): Upper limit of range comparison. (S): Comparative value. (D): Results of comparison.
- When the comparative value (S) is compared with the lower limit (S1) and upper limit (S2), the results of comparison are expressed in (D).
- When lower limit (S1) > upper limit (S2), the command will use the lower limit (S1) to perform comparison with the upper and lower limit.
- Size comparison is performed algebraically. All data is compared in the form of numerical binary values. Because this is a 16-bit command, when b15 is 1, this indicates a negative number.

Example

- When the designated device is M0, it automatically occupies M0, M1 and M2.
- When X0=On, the ZCP command executes, and M0, M1 or M2 will be On. When X0=Off, the ZCP command will not execute, and the state of M0, M1 or M2 will remain in the state prior to X0=Off.
- If ≥, ≤, or ≠ results are needed, they can be obtained via series/parallel connections of M0–M2.

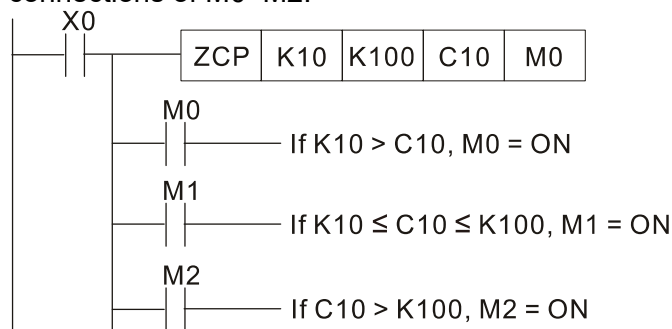

- To clear results of comparison, use the RST or ZRST command.

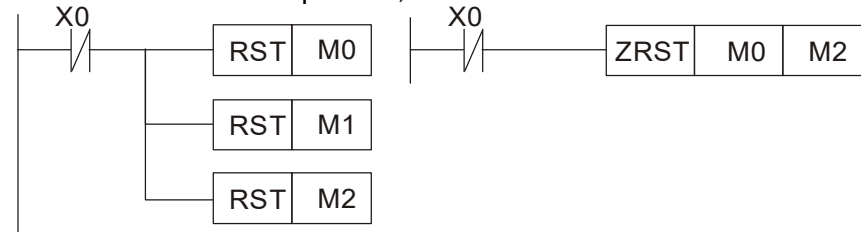

API 12	D	<b>MOV</b>	P	(S)	(D)	Data movement								
Bit device			Word device								16-bit command (5 STEP)			
X	Y	M	K	H	KnX	KnY	KnM	T	C	D	MOV	Continuous execution type	MOVP	Pulse execution type
S			*	*	*	*	*	*	*	*				
D						*	*	*	*	*				
Notes on operand usage: none											32-bit command (9 STEP)			
											DMOV	Continuous execution type	DMOVP	Pulse execution type
											Flag signal:			

- Explanation**
- (S): Data source. (D): Destination of data movement.
  - When this command is executed, the content of (S) will be directly moved to (D). When the command is not executed, the content of (D) will not change.

- Example**
- When X0=Off, the content of D10 will not change; if X0=On, the value K10 will be sent to data register D10.
  - When X1=Off, the content of D10 will not change; if X1=On, the current value of T0 will be sent to data register D10.

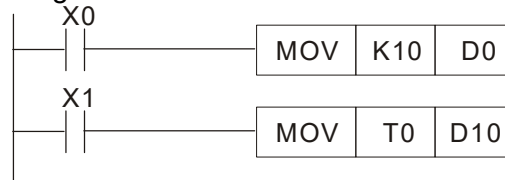

API 13	D	<b>SMOV</b>	P	(S)	(m1)	(m2)	(D)	(n)	Nibble movement					
Bit device		Word device									16-bit command (11 STEP)			
X	Y	M	K	H	KnX	KnY	KnM	T	C	D	MOV	Continuous execution type	SMOVP	Pulse execution type
S			*	*	*	*	*	*	*	*				
D						*	*	*	*	*				
Notes on operand usage: none											32-bit command (21 STEP)			
											DSMOV	Continuous execution type	DSMOV	Pulse execution type
											Flag signal: M1168			

Explanation

- (S) : Data source. (m1) : The data source transfers starting bit number.
- (m2) : The data source transfers individual bit number. (D) : Transfer destination.
- (n) Transferring starting bit number of the destination.
- BCD mode (M1168 = Off):  
SMOV enables and operates BCD under this mode, the operation is similar to the way SMOV operates decimal numbers. The command copies specific bit number of arithmetic element S (S is a 4-figure decimal number), and sends the bit number to arithmetic element D (D is also a 4-figure decimal number). The current data on the target register will be covered.
- m<sub>1</sub> range: 1–4
- m<sub>2</sub> range: 1–m<sub>1</sub> (m<sub>2</sub> cannot be larger than m<sub>1</sub>)
- n range: m<sub>2</sub>–4 (n cannot be smaller than m<sub>2</sub>)

Example 1

- When M1168 = Off (BCD mode), X0 is ON, the instruction transfers two digits of the decimal number starting from the fourth digit of the decimal number (the digit in the thousands place of the decimal number) in D10 to the two digits of the decimal number starting from the third digit of the decimal number (the digit in the hundreds place of the decimal number) in D20. After the instruction is executed, the digits in the thousands place of the decimal number (10<sup>3</sup>) and the ones place of the decimal number (10<sup>0</sup>) in D20 are unchanged.

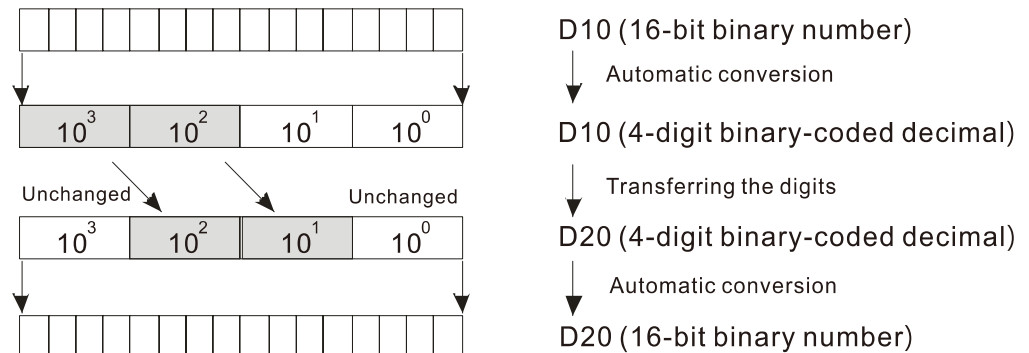
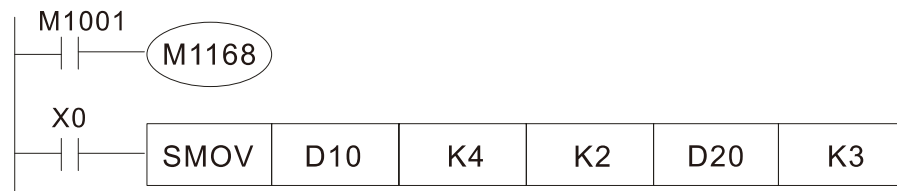



Example 2

- When M1168 is On (BIN mode), and the SMOV command is executed, D10 and D20 do not change in BCD mode, but send 4 digits as a unit in BIN mode.

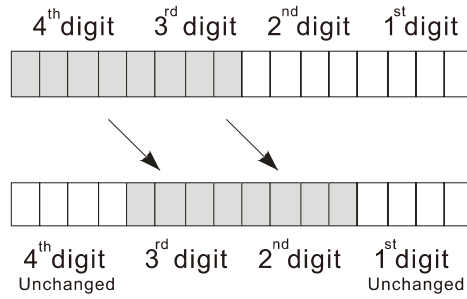
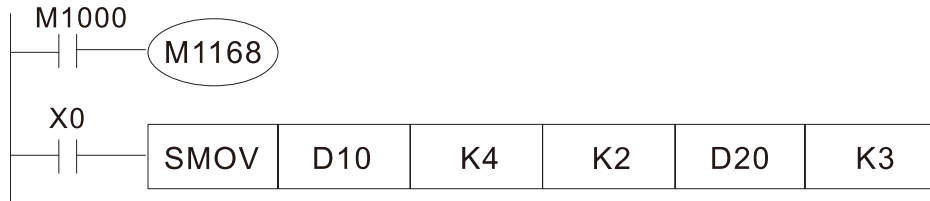

D10 (16-bit binary number)

↓ Transferring the digits

D20 (16-bit binary number)

API 15	<b>BMOV</b>	<b>P</b>	(S)	(D)	(n)	Send all									
Bit device		Word device										16-bit command (7 STEP)			
X	Y	M	K	H	KnX	KnY	KnM	T	C	D	BMOV	Continuous execution type	BMOV P	Pulse execution type	
S					*	*	*	*	*	*					
D						*	*	*	*	*					
n			*	*				*	*						
Notes on operand usage: n operand scope n = 1 to 512											32-bit command				
											Flag signal: none				

Explanation

- (S): Initiate source device. (D): Initiate destination device. (n): Send block length.
- The content of n registers starting from the initial number of the device designated by (S) will be sent to the n registers starting from the initial number of the device designated by (D); if the number of points referred to by n exceeds the range used by that device, only points within the valid range will be sent.

Example 1

- When X10=On, the content of registers D0–D3 will be sent to the four registers D20 to D23.

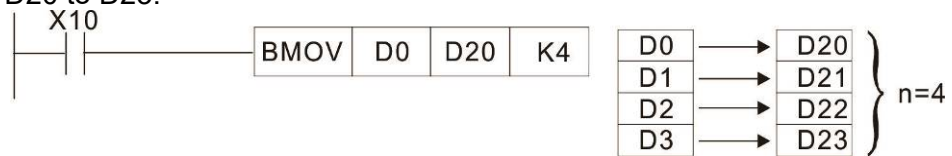

Example 2

- If the designated bit devices KnX, KnY, and KnM are sent, (S) and (D) must have the same number of nibbles, which implies that n must be identical.

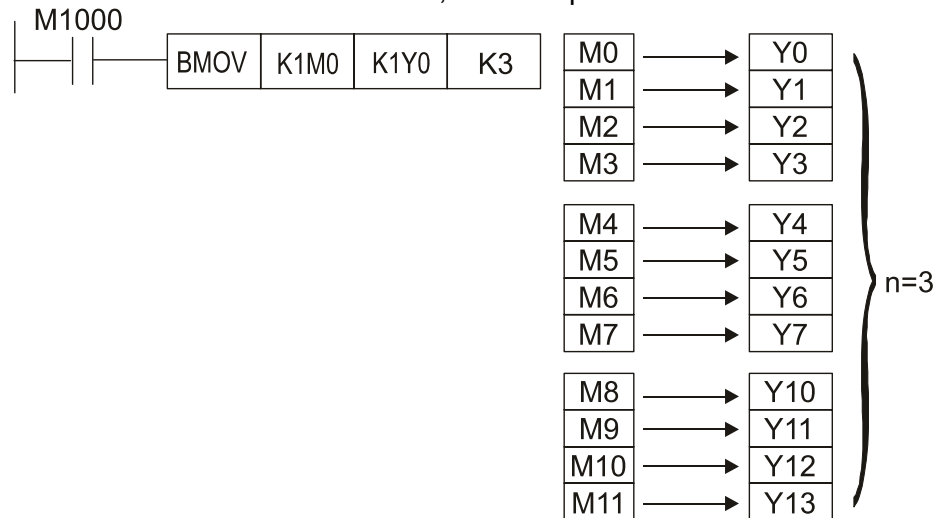

Example 3

- In order to prevent overlap between the transmission addresses of two operands, which would cause confusion, make sure that the addresses designated by the two operands have different sizes, as shown below:

When (S) > (D), send in the order ① → ② → ③.

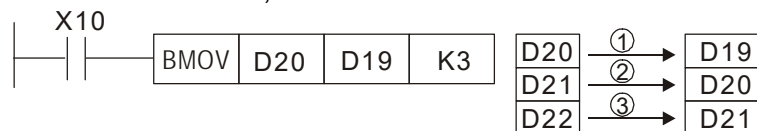

When (S) < (D), send in the order ③ → ② → ①.

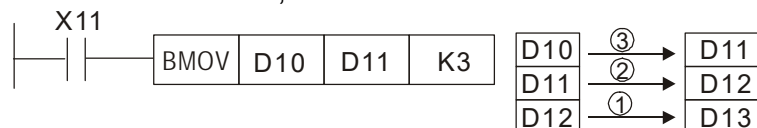

API 18	D	BCD	P	(S)	(D)	BIN to BCD transformation									
Bit device		Word device										16-bit command (5 STEP)			
X	Y	M	K	H	KnX	KnY	KnM	T	C	D	BCD	Continuous execution type	BCDP	Pulse execution type	
S					*	*	*	*	*	*					
D						*	*	*	*	*					
Notes on operand usage: none											32-bit command (9 STEP)				
											DBCD	Continuous execution type	DBCDP	Pulse execution type	
											Flag signal: none				

- Explanation**
- (S) : Data source. (D) : Destination of data movement.
  - The content of data source (S) (BIN value, 0–9999) executes BCD transformation and saves in (D).
  - Arithmetic elements S and D use the F device, it can only use 16-bit command.

- Example**
- When X0 is ON, and the BIN value of D10 is transformed to BCD value, the digit is saved in 4-bit element of K1Y0 (Y0–Y3).

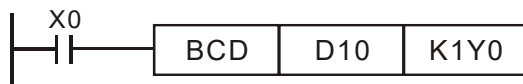

- If D10 = 001E (Hex) = 0030 (Decimal), the executed result will be Y0–Y3=0000 (BIN).

API 19	D	<b>BIN</b>	P	(S)	(D)	BCD to BIN transformation									
Bit device			Word device									16-bit command (5 STEP)			
X	Y	M	K	H	KnX	KnY	KnM	T	C	D	BIN	Continuous execution type	BINP	Pulse execution type	
S					*	*	*	*	*	*					
D						*	*	*	*	*					
Notes on operand usage: none											32-bit command (9 STEP)				
											DBIN	Continuous execution type	DBINP	Pulse execution type	
											Flag signal: none				

Explanation

- (S) : Data source. (D) : Transformation result.
- The content of data source (S) (BCD: 0–9,999) executes BIN transformation and saves in (D).
- Valid number range of the data source S: BCD (0–9,999), DBCD (0–99,999,999).

Example

- When X0 is ON, and the BCD value of K1X20 is transformed to BIN value, the result saves in D10.

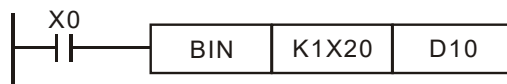

Remark

- When PLC reads a BCD type switch-off from the outside, it has to use the BIN command to transform the read data to BIN value, then saves the value into PLC.

API 20	D	<b>ADD</b>	P	(S1)	(S2)	(D)	BIN addition								
Bit device				Word device								16-bit command (7 STEP)			
X	Y	M	K	H	KnX	KnY	KnM	T	C	D	ADD	Continuous execution type	ADDP	Pulse execution type	
S1			*	*	*	*	*	*	*	*					
S2			*	*	*	*	*	*	*	*					
D						*	*	*	*	*					
Notes on operand usage: none											32-bit command (13 STEP)				
											DADD	Continuous execution type	DADDP	Pulse execution type	
											Flag signal: M1020 Zero flag M1021 Borrow flag M1022 Carry flag Please refer to the following supplementary explanation				

Explanation

- (S1): Augend. (S2): Addend. (D): Sum.
- Using two data sources: The result of adding (S1) and (S2) using the BIN method will be stored in (D).
- The highest bit of any data is symbolized as bit 0 indicating (positive) 1 indicating (negative), enabling the use of algebraic addition operations. (for instance: 3+(-9)=-6)
- Flag changes connected with the addition.
  1. When calculation results are 0, the zero flag M1020 will be On.
  2. When calculation results are less than -32,768, the borrow flag M1021 will be On.
  3. When calculation results are greater than 32,767, the carry flag M1022 will be On.

Example

- 16-bit BIN addition: When X0=On, the result of the content of addend D0 plus the content of augend D10 will exist in the content of D20.



Remark

- Relationship between flag actions and negative/positive numbers: 16-bit:

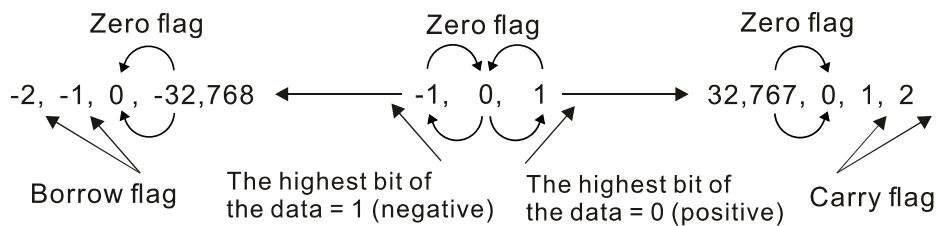

32-bit:

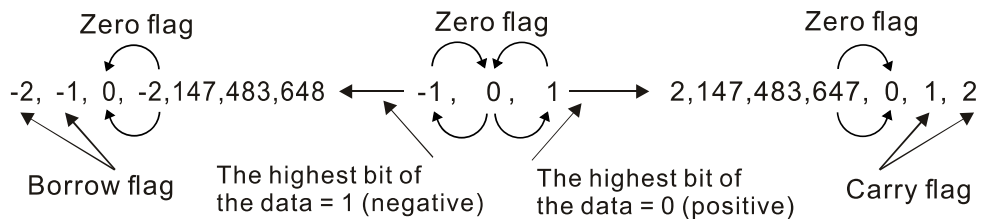

API 21	D	<b>SUB</b>	P	(S1)	(S2)	(D)	BIN subtraction							
Bit device			Word device								16-bit command (7 STEP)			
X	Y	M	K	H	KnX	KnY	KnM	T	C	D	SUB	Continuous execution type	SUBP	Pulse execution type
S1			*	*	*	*	*	*	*	*				
S2			*	*	*	*	*	*	*	*				
D						*	*	*	*	*				
Notes on operand usage: none											32-bit command (13 STEP)			
											DSUB	Continuous execution type	DSUBP	Pulse execution type
											Flag signal: M1020 Zero flag M1021 Borrow flag M1022 Carry flag Please refer to the following supplementary explanation			

Explanation

- (S1): Minuend. (S2): Subtrahend. (D): Difference.
- Using two data sources: The result of subtraction of (S1) and (S2) using the BIN method is stored in (D).
- The highest bit of any data is symbolized as bit 0 indicating (positive) 1 indicating (negative), enabling the use of algebraic subtraction operations.
- Flag changes connected with subtraction.
  1. When calculation results are 0, the zero flag M1020 will be On.
  2. When calculation results are less than -32,768, the borrow flag M1021 will be On.
  3. When calculation results are greater than 32,767, the carry flag M1022 will be On.

Example

- 16-bit BIN subtraction: When X0=On, the content of D10 is subtracted from the content of D0, and the difference is stored in D20.

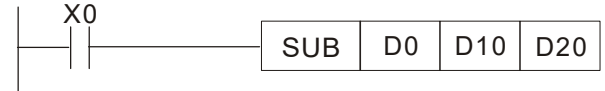

API 22	D	MUL	P	(S1)	(S2)	(D)	BIN multiplication							
Bit device			Word device								16-bit command (7 STEP)			
X	Y	M	K	H	KnX	KnY	KnM	T	C	D	MUL	Continuous execution type	MULP	Pulse execution type
S1			*	*	*	*	*	*	*	*				
S2			*	*	*	*	*	*	*	*				
D						*	*	*	*	*				
Notes on operand usage: The 16-bit command operand D will occupy 2 consecutive points											32-bit command (13 STEP)			
											DMUL	Continuous execution type	DMULP	Pulse execution type
											Flag signal: none			

- Explanation**
- (S1): Multiplicand. (S2): Multiplier. (D): Product.
  - Using two data sources: When (S1) and (S2) are multiplied using the BIN method, the product is stored in (D).

16-bit BIN multiplication operation:

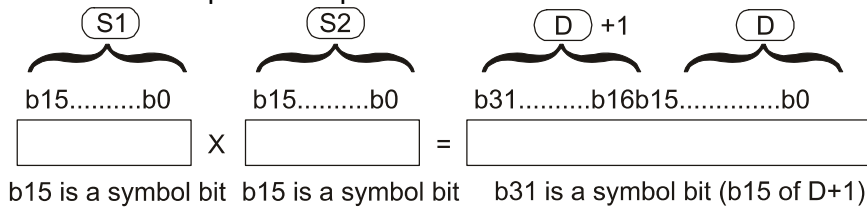

Symbol bit = 0 refers to a positive value  
Symbol bit = 1 refers to a negative value

When (D) is a bit device, K1–K4 can be designated as a hexadecimal number, which will occupy 2 consecutive units.

- Example**
- When 16-bit D0 is multiplied by 16-bit D10, the result will be a 32-bit product; the upper 16 bits will be stored in D21, and the lower 16 bits will be stored in D20. Whether the bit at the farthest left is Off or On will indicate the sign of the result.

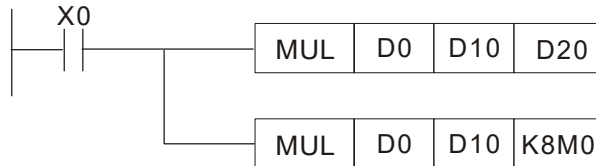

API 23	D	DIV	P	(S1)	(S2)	(D)	BIN division								
Bit device			Word device									16-bit command (7 STEP)			
X	Y	M	K	H	KnX	KnY	KnM	T	C	D	DIV	Continuous execution type	DIVP	Pulse execution type	
S1			*	*	*	*	*	*	*	*					
S2			*	*	*	*	*	*	*	*					
D						*	*	*	*	*					
Notes on operand usage: The 16-bit command operand D will occupy 2 consecutive points											32-bit command (13 STEP)				
											DDIV	Continuous execution type	DDIVP	Pulse execution type	
Flag signal: none															

Explanation

- (S1): Dividend. (S2): Divisor. (D): Quotient and remainder.
- Using two data sources: The quotient and remainder will be stored in (D) when (S1) and (S2) are subjected to division using the BIN method. The sign bit for (S1), (S2) and (D) must be kept in mind when performing a 16-bit operation.

16-bit BIN division:

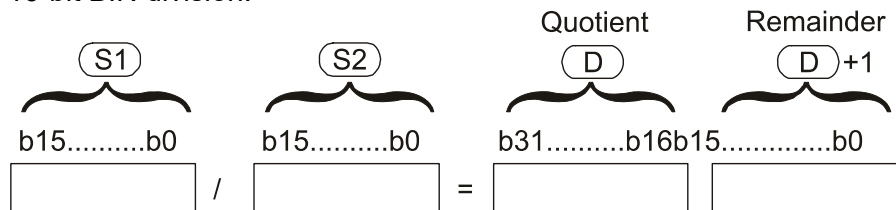

If (D) is a bit device, K1–K4 can be designated 16 bits, which will occupy 2 consecutive units and yield the quotient and remainder.

Example

- When X0=On, the quotient resulting from division of dividend D0 by divisor D10 will be placed in D20, and the remainder will be placed in D21. Whether the highest bit is Off or On will indicate the sign of the result.

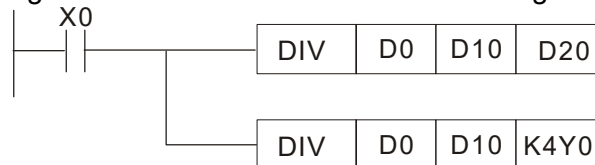



API 24	D	INC	P	(D)	BIN add one										
Bit device			Word device									16-bit command (3 STEP)			
X	Y	M	K	H	KnX	KnY	KnM	T	C	D	INC	Continuous execution type	INCP	Pulse execution type	
D						*	*	*	*	*					
Notes on operand usage: none											32-bit command (5 STEP)				
											DINC	Continuous execution type	DINCP	Pulse execution type	
											Flag signal: none				

- Explanation**
- (D): Destination device.
  - If a command is not the pulse execution type, when the command is executed, the program will add 1 to the content of device (D) for each scanning cycle.
  - This command is ordinarily used as a pulse execution type command (INCP).
  - During 16-bit operation, 32,767 +1 will change the value to -32,768. During 32 bit operation, 2,147,483,647 +1 will change the value to -2,147,483,648.

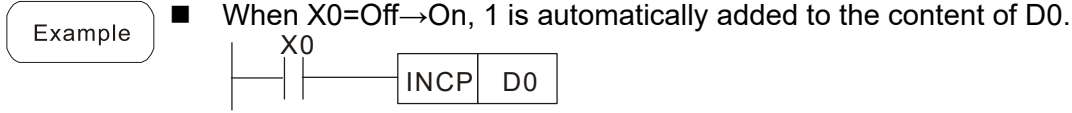

API 25	D	DEC	P	(D)	BIN subtract one									
Bit device			Word device								16-bit command (3 STEP)			
X	Y	M	K	H	KnX	KnY	KnM	T	C	D	DEC	Continuous execution type	DECP	Pulse execution type
D			*	*	*	*	*							
Notes on operand usage: none											32-bit command (5 STEP)			
											DDEC	Continuous execution type	DDECP	Pulse execution type
											Flag signal: none			

Explanation

- (D): Destination device.
- If a command is not the pulse execution type, when the command is executed, the program will add 1 to the content of device (D) for each scanning cycle.
- This command is ordinarily used as a pulse execution type command (DECP).
- During 16-bit operation, -32,768 minus 1 will change the value to 32,767. During 32 bit operation, -2,147,483,648 minus 1 will change the value to -2,147,483,647.

Example

- When X0=Off→On, 1 is automatically subtracted from the content of D0.



API 30	D	ROR	P	(D)	(n)	Right rotation								
Bit device		Word device									16-bit command (5 STEP)			
X	Y	M	K	H	KnX	KnY	KnM	T	C	D	ROR	Continuous execution type	RORP	Pulse execution type
D						*	*	*	*	*				
n			*	*							32-bit command (9 STEP)			
Notes on operand usage: Only K4 (16-bit) will be valid if the operand D is designated as KnY or KnM. n operand n=K1-K16 (16-bit)											DROR	Continuous execution type	DRORP	Pulse execution type
											Flag signal: M1022 Carry flag			

- Explanation**
- (D): Device to be rotated. (n): Number of bits for one rotation.
  - Rotates the device designated by (D) to the right (n) bits.
  - This command is ordinarily used as a pulse execution type command (RORP).
- Example**
- When X0=Off→On, 4 of the 16 bits in D10 specify a right rotation; the content of the bit indicated with \* (see figure below) will be sent to the carry flag signal M1022.

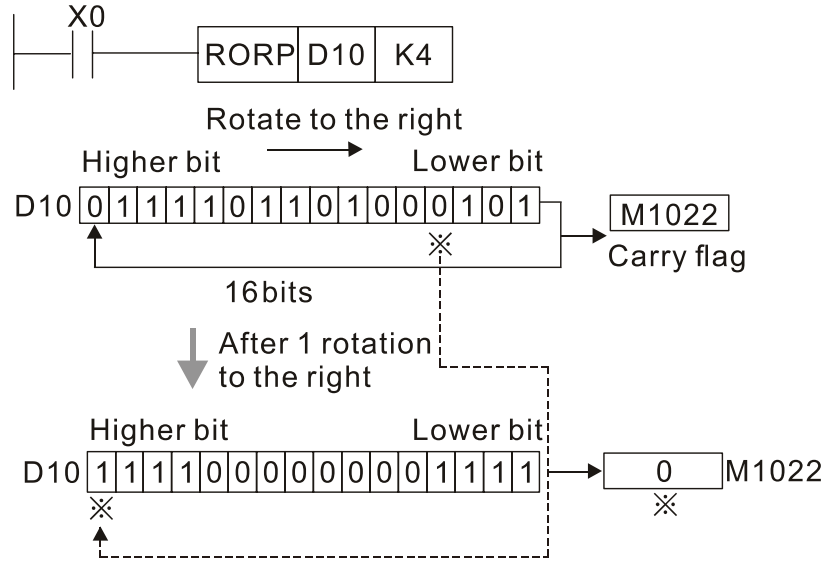

API 31	<b>D</b>	<b>ROL</b>	<b>P</b>	(D) (n)								Left rotation			
Bit device			Word device								16-bit command (5 STEP)				
X	Y	M	K	H	KnX	KnY	KnM	T	C	D	ROL	Continuous execution type	ROLP	Pulse execution type	
D						*	*	*	*	*					
n			*	*											
Notes on operand usage: Only K4 (16-bit) will be valid if the operand D is designated as KnY or KnM. n operand n=1 to 16 (16-bit)											32-bit command (9 STEP)				
											DROL	Continuous execution type	DROLP	Pulse execution type	
Flag signal: M1022     Carry flag															

**Explanation**

- (D): Device to be rotated. (n): Number of bits for one rotation.
- Rotates the device designated by (D) to the left (n) bits.
- This command is ordinarily used as a pulse execution type command (ROLP).

**Example**

- When X0=Off→On, 4 of the 16 bits in D10 specify a left rotation; the content of the bit indicated with \* (see figure below) will be sent to the carry flag signal M1022.

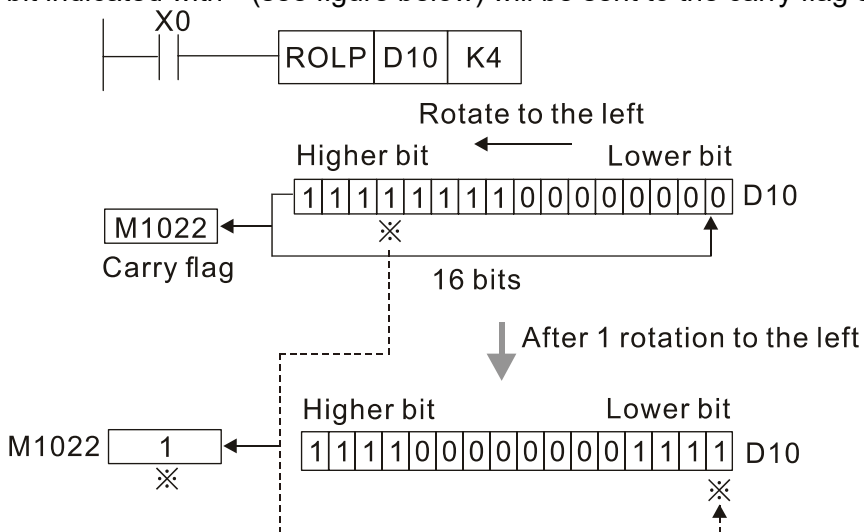

API 40	ZRST	P	(D1) (D2)	Clear range
-----------	------	---	-----------	-------------

	Bit device			Word device								16-bit command (5 STEP)			
	X	Y	M	K	H	KnX	KnY	KnM	T	C	D	ZRST	Continuous execution type	ZRSTP	Pulse execution type
D1	*	*	*						*	*	*				
D2	*	*	*						*	*	*				

Notes on operand usage:  
 Number of operand D<sub>1</sub> operand ≤ number of operand D<sub>2</sub>  
 Operands D<sub>1</sub>, D<sub>2</sub> must designate the same type of device  
 Please refer to the function specifications table for each device in series for the scope of device usage

32-bit command

Flag signal: none

- Explanation**
- **D<sub>1</sub>**: Clear range's initial device. **D<sub>2</sub>**: Clear range's final device.
  - When the number of operand D<sub>1</sub> > number of operand D<sub>2</sub>, only the operand designated by D<sub>2</sub> will be cleared.

- Example**
- When X0 is On, auxiliary relays M300–M399 will be cleared and changed to Off.
  - When X1 is On, 16-bit counters C0–C127 will all be cleared. (Writes 0, and clears and changes contact and coil to Off).
  - When X10 is On, timer T0–T127 will all be cleared. (Writes 0, and clears and changes contact and coil to Off).
  - When X3 is On, the data in data registers D0–D100 will be cleared and set as 0.

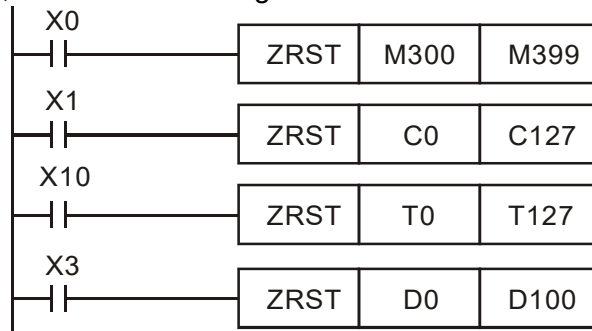

- Remark**
- Devices can independently use the clear command (RST), such as bit device Y, M and word device T, C, D.

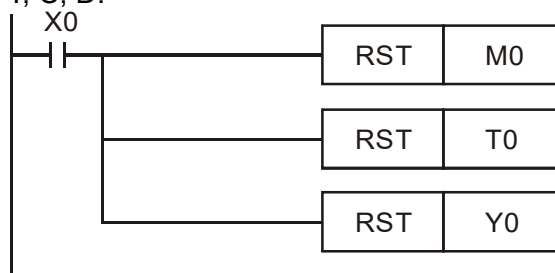

API 41	D	DECO	P	(S)	(D)	(n)	Decoder								
	Bit device			Word device							16-bit command (7 STEP)				
	X	Y	M	K	H	KnX	KnY	KnM	T	C	D	DECO	Continuous execution type	DECOP	Pulse execution type
S	*	*	*	*	*				*	*	*				
D		*	*				*	*	*	*	*				
n				*	*										
Notes on operand usage: none												32-bit command (13 STEP)			
												DDECO	Continuous execution type	DDECOP	Pulse execution type
Flag signal: none															

Explanation

- (S): Decoding source device. (D): Device that saves the decoding result.
- (n): Length of decoding bit.
- Decodes with the lower “n” bit, and saves the length of “2<sup>n</sup>” bit in D.
- This command usually uses pulse execution type command (DECOP).
- When D is the bit device, n = 1–8, when D is the word device, n = 1–4.

Example 1

- When Dis the bit device, the valid range of n is 0 < n ≤ 8. If n = 0 or n > 8, a fault will occur.
- When n = 8, the maximum decoding will be 2<sup>8</sup> = 256 points.
- When M200 switches from Off to On, the content of X0–X2 is decoded to M100–M107.
- If S = 3, M103 (the third digit starting from M100) = On.
- When the command is executed, M200 turns to Off. The ones that are decoded and outputted act as usual.

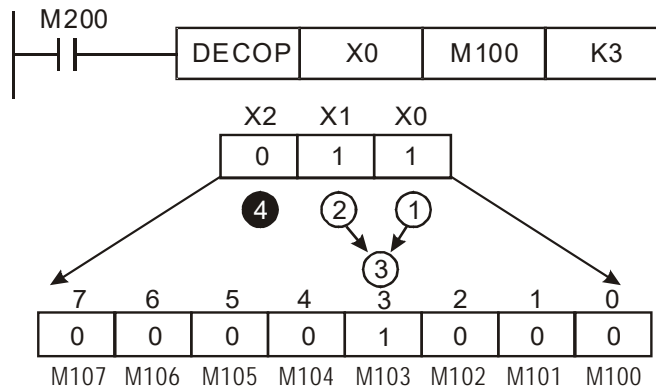

Example 2

- When D is word device, the valid range of n is 0 < n ≤ 4. If n = 0 or n > 4, the fault occurs.
- When n = 4, the maximum decoding will be 2<sup>4</sup> = 16 points.
- When M200 switches from Off to On, the content of D10 (b2–b0) is decoded to D20 (b7–b0). The unused digits (b15–b8) of D20 become 0.
- The lower 3 digits of D10 are decoded and saved in the lower 8 digits of D20, the upper 8 digits are 0.
- When the command is executed, M200 turns to Off. The ones that are decoded and outputted act as usual.

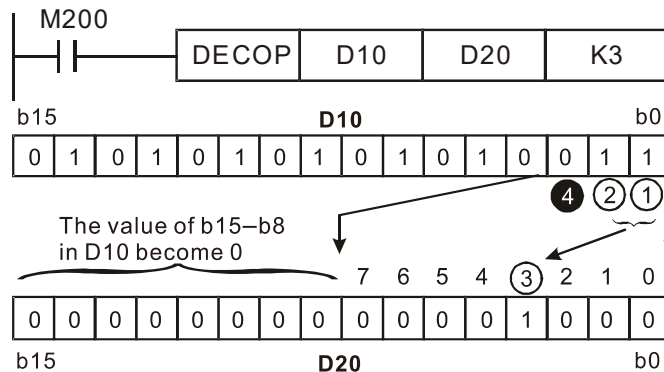

API 42	D	ENCO	P	(S)	(D)	(n)	Encoder							
Bit device		Word device										16-bit command (7 STEP)		
X	Y	M	K	H	KnX	KnY	KnM	T	C	D	ENCO	Continuous execution type	ENCOP	Pulse execution type
S	*	*	*					*	*	*				
D						*	*	*	*	*				
n			*	*										
Notes on operand usage: none											32-bit command (13 STEP)			
											DENCO	Continuous execution type	DENCOP	Pulse execution type
											Flag signal: none			

- Explanation**
- S: Encoding source device. D: Device that saves the encoding result.
  - n: Length of encoding bit.
  - Encodes the data of lower “2<sup>n</sup>” bit length from encoding source device S, and saves the encoding result in D.
  - If multiple digits of encoding source device are 1, the command will process the first digit starting from high digit.
  - This command usually uses pulse execution type command (ENCOP).
  - When S is the bit device, n = 1–8, when S is the word device, n = 1–4.

- Example 1**
- When S is the bit device, the valid range of n is 0 < n ≤ 8. If n = 0 or n > 8, a fault will occur.
  - When n = 8, the maximum decoding will be 2<sup>8</sup> = 256 points.
  - When X0 switches from Off to On, the content of 2<sup>3</sup> digit (M0–M7) is encoded and saved in the lower 3 digits (b2–b0). The unused digits (b15–b3) in D0 become 0.
  - When the command is executed, X0 turns to Off. The data in D is unchanged.

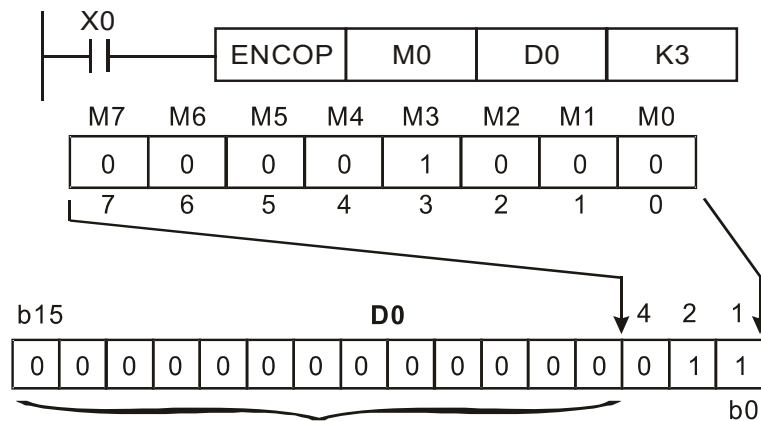

The value becomes 0

- Example 2**
- When S is word device, the valid range of n is 0 < n ≤ 4. If n = 0 or n > 4, the fault occurs.
  - When n = 4, the maximum decoding will be 2<sup>4</sup> = 16 points.
  - When X0 switches from Off to On, 2<sup>3</sup> digit data of D10 (b0–b7) is encoded and saved in the lower 3 digits (b2–b0) of D20. The unused digits (b15–b3) of D20 become 0. (b8–b15 in D10 are invalid data)
  - When the command is executed, X0 turns to Off. The data in D is unchanged.

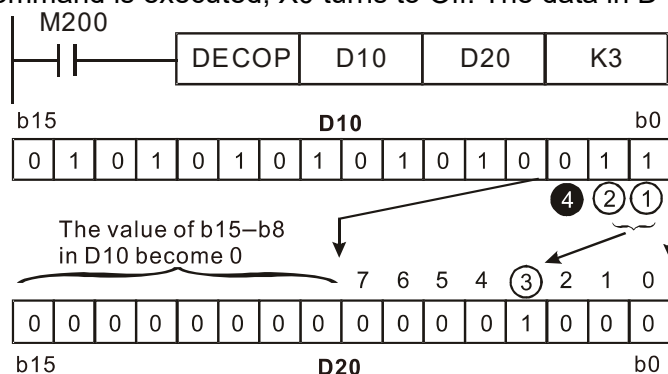

The value of b15–b8 in D10 become 0

API 43	D	<b>SUM</b>	P	(S) (D)	ON bit number										
Bit device		Word device										16-bit command (5 STEP)			
X	Y	M	K	H	KnX	KnY	KnM	T	C	D	SUM	Continuous execution type	SUMP	Pulse execution type	
S			*	*	*	*	*	*	*	*					
D								*	*	*					
Notes on operand usage: none											32-bit command (9 STEP)				
											DSUM	Continuous execution type	DSUMP	Pulse execution type	
											Flag signal: M1020				

Explanation

- (S) : Source device. (D) : Destination of saving counter values.
- The total amount of all digits that is “1” in S will be saved in D.
- D will use 2 registers when use the 32-bit command.
- Arithmetic elements S and D use F device, and can only use 16-bit command.
- If there is no bit is ON, the flag signal M1020 will be ON.
- When M200 = On, the total amount of content “1” digit in D0’s 16-bit command will be saved in D2.

Example

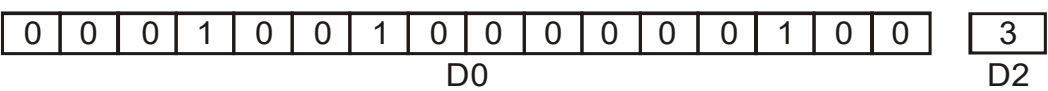



API 44	D	BON	P	(S)	(D)	(n)	ON bit judgement								
Bit device			Word device									16-bit command (7 STEP)			
X	Y	M	K	H	KnX	KnY	KnM	T	C	D	BON	Continuous execution type	BONP	Pulse execution type	
S			*	*	*	*	*	*	*	*					
D	*	*						*	*	*					
n			*	*											
Notes on operand usage: none											32-bit command (9 STEP)				
											DBON	Continuous execution type	DBONP	Pulse execution type	
											Flag signal: none				

- Explanation
- (S): Source device. (D): Destination of saving judging result. (n): assign judged digit (numbering from 0)
  - The status of specific digit from source device is shown on target position.
  - Arithmetic element S uses F device, and can only use the 16-bit command.
  - The valid range of arithmetic element n: n = 0–15 (16-bit), n = 0–31 (32-bit).

- Example
- When X0 = On, if the 15<sup>th</sup> digit of D0 is “1”, M0 is On. If it is “0”, M0 is Off.
  - When X0 turns to Off, M0 remains previous status.



API 49	D	FLT	P	(S) (D)	BIN whole number → binary decimal transformation										
	Bit device			Word device								16-bit command (5 STEP)			
	X	Y	M	K	H	KnX	KnY	KnM	T	C	D	FLT	Continuous execution type	FLTP	Pulse execution type
S		*	*						*	*	*				
D		*	*						*	*	*				
Notes on operand usage: Please refer to the function specifications table for each device in series for the scope of device usage The operand D will occupy 2 consecutive points												32-bit command (9 STEP)			
												DFLT	Continuous execution type	DFLTP	Pulse execution type
Flag signal: none															

Explanation

- **S**: Transformation source device. **D**: Device storing transformation results.
- Transforms BIN whole number into a binary decimal value.

Example

- When M200 is On, converts the whole number of values corresponding to D0 and D1 into floating point numbers, which are placed in D20 and D21.

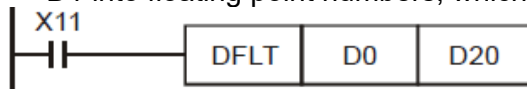

API 110	D	ECMP	P	(S <sub>1</sub> ) (S <sub>2</sub> ) (D)	Comparison of binary floating point numbers
------------	---	------	---	---	---

	Bit device			Word device								16-bit command				
	X	Y	M	K	H	KnX	KnY	KnM	T	C	D					
S1				*	*							*				
S2				*	*							*	32-bit command (13 STEP)			
D				*	*							*	DECMP	Continuous	DECMP	Pulse
Notes on operand usage: The operand D occupies three consecutive points Please refer to the function specifications table for each device in series for the scope of device usage												execution type	P	execution type		
												Flag signal: none				

**Explanation** ■ **S<sub>1</sub>**: Comparison of binary floating point numbers value 1. **S<sub>2</sub>**: Comparison of binary floating point numbers value 2. **D**: Results of comparison, occupies 3 consecutive points.

- When binary floating point number 1 is compared with comparative binary floating point number 2, the result of comparison (>, =, <) will be expressed in **D**.
- If the source operand **S<sub>1</sub>** or **S<sub>2</sub>** designates a constant K or H, the command will transform the constant to a binary floating-point number for the purpose of comparison.

- Example**
- When the designated device is M10, it will automatically occupy M10–M12.
  - When X0=On, the DECMP command executes, and one of M10–M12 will be On. When X0=Off, the DECMP command will not execute, and M10–M12 will remain in the X0=Off state.
  - If results in the form of ≥, ≤, or ≠ are needed, they can be obtained by series and parallel connection of M10–M12.
  - Please use the RST or ZRST command to clear the result.

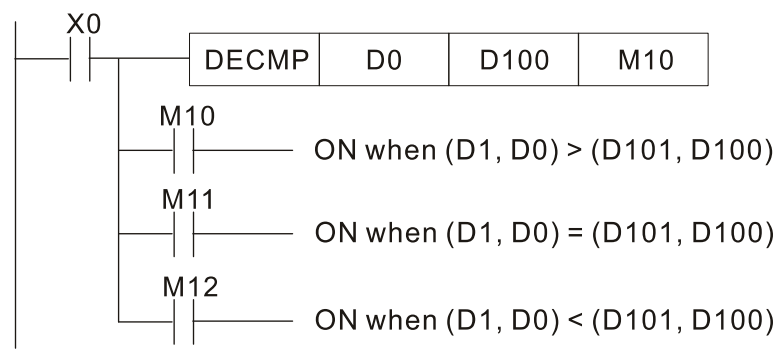

API 111	D	EZCP	P	S <sub>1</sub>	S <sub>2</sub>	S	D	Comparison of binary floating point number range				
Bit device		Word device										
	X	Y	M	K	H	KnX	KnY	KnM	T	C	D	16-bit command
S1				*	*						*	-----
S2				*	*						*	-----
S				*	*						*	32-bit command (17 STEP)
D		*	*									DEZCP : Continuous : DEZCP : Pulse execution type : P : execution type
Notes on operand usage: The operand D occupies three consecutive points Please refer to the function specifications table for each device in series for the scope of device usage											Flag signal: none	

Explanation

- **S<sub>1</sub>**: Lower limit of binary floating point number in range comparison. **S<sub>2</sub>**: Upper limit of binary floating point number in range comparison. **S**: Comparison of binary floating point numerical values. **D**: Results of comparison, occupies 3 consecutive points.
- Comparison of binary floating point numerical value **S** with binary floating point number lower limit value **S<sub>1</sub>** and binary floating point number upper limit value **S<sub>2</sub>**; the results of comparison are expressed in **D**.
- **If the source operand S<sub>1</sub> or S<sub>2</sub> designates a constant K or H, the command will transform the constant to a binary floating-point number for the purpose of comparison.**
- When the lower limit binary floating point number **S<sub>1</sub>** is greater than the upper limit binary floating point number **S<sub>2</sub>**, a command will be issued to perform comparison with the upper and lower limits using the binary floating point number lower limit value **S<sub>1</sub>**.

Example

- When the designated device is M0, it will automatically occupy M0–M2.
- When X0=On, the DEZCP command will be executed, and one of M0–M2 will be On. When X0=Off, the EZCP command will not execute, and M0–M2 will continue in the X0=Off state.
- Please use the RST or ZRST command to clear the result.

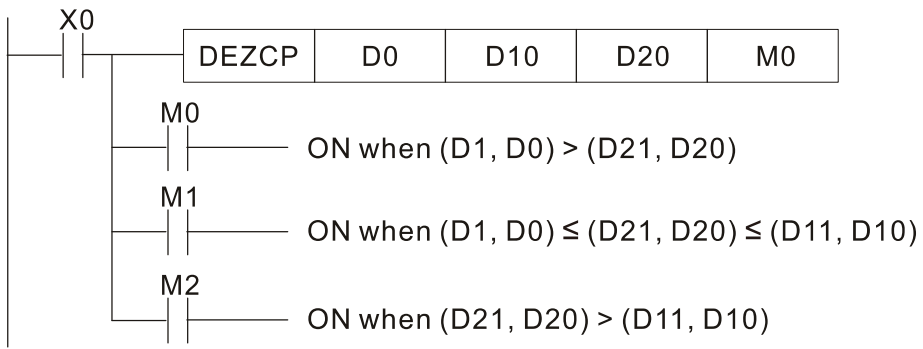

API 116	D	RAD	P	(S) (D)	Angle → Diameter										
Bit device		Word device										16-bit command			
X	Y	M	K	H	KnX	KnY	KnM	T	C	D	-	-	-	-	
S			*	*						*	32-bit command (9 STEP)				
D										*	DRAD	Continuous	DRADP	Pulse	
Notes on operand usage: Please refer to the function specifications table for each device in series for the scope of device usage											execution type				
											Flag signal: none				

- Explanation
- **S:** data source (angle). **D:** result of transformation (diameter).
  - Uses the following formula to convert angles to radians.
  - $Diameter = Angle \times (\pi/180)$

- Example
- When X0=On, the angle of the designated binary floating point number (D1, D0) will be converted to radians and stored in (D11, D10), with the content consisting of a binary floating point number.

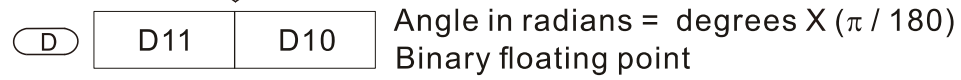
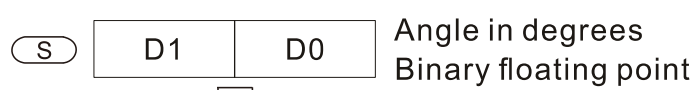
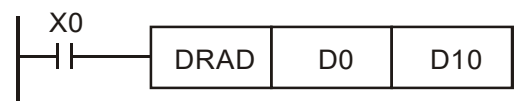

API 117	D	DEG	P	(S) (D)	Diameter → angle									
Bit device			Word device								16-bit command			
X	Y	M	K	H	KnX	KnY	KnM	T	C	D	-	-	-	-
S			*	*						*	32-bit command (9 STEP)			
D										*	DDEG	Continuous execution type	DDEGP	Pulse execution type
Notes on operand usage: Please refer to the function specifications table for each device in series for the scope of device usage											Flag signal: none			

Explanation

- **S**: data source (diameter). **D**: results of transformation (angle).
- Uses the following formula to convert radians to an angle.
- $Angle = Diameter \times (180/\pi)$

Example

- When X0=On, angle of the designated binary floating point number (D1, D0) in radians will be converted to an angle and stored in (D11, D10), with the content consisting of a binary floating point number.



(S) [ D1 | D0 ] Angle in radians  
Binary floating point



(D) [ D11 | D10 ] Angle in degrees = radians X ( 180 / π )  
Binary floating point

API 120	D	EADD	P	(S <sub>1</sub> )	(S <sub>2</sub> )	(D)	Adding binary floating point numbers					
Bit device		Word device										16-bit command
X	Y	M	K	H	KnX	KnY	KnM	T	C	D		
S1			*	*							*	
S2			*	*							*	32-bit command (9 STEP)
D											*	DEADD : Continuous execution type
Notes on operand usage: Please refer to the function specifications table for each device in series for the scope of device usage											DEADDP : Pulse execution type	
											Flag signal: none	

- Explanation**
- **S<sub>1</sub>**: addend. **S<sub>2</sub>**: augend. **D**: sum.
  - When the content of the register designated by **S<sub>2</sub>** is added to the content of the register designated by **S<sub>1</sub>**, and the result is stored in the register designated by **D**. Addition is performed entirely using binary floating-point numbers.
  - **If the source operand S<sub>1</sub> or S<sub>2</sub> designates a constant K or H, the command will transform that constant into a binary floating point number for use in addition.**
  - **In the situation when S<sub>1</sub> and S<sub>2</sub> designate identical register numbers, if a "continuous execution" command is employed, when conditional contact is On, the register will perform addition once during each scan. Pulse execution type commands (DEADDP) are generally used under ordinary circumstances.**

- Example**
- When X0=On, a binary floating point number (D1, D0) will be added to a binary floating point number (D3, D2), and the results stored in (D11, D10).

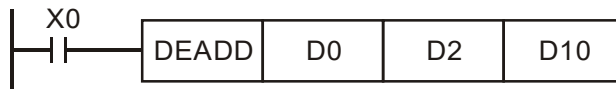

- When X2 =On, a binary floating point number (D11, D10) will be added to K1234 (which has been automatically converted to a binary floating-point number), and the results stored in (D21, D20).

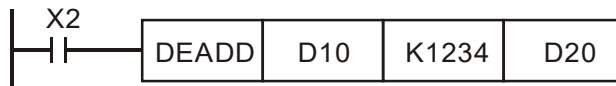

API 121	D	ESUB	P	(S <sub>1</sub> )	(S <sub>2</sub> )	(D)	Subtraction of binary floating point numbers												
	Bit device			Word device								16-bit command							
	X	Y	M	K	H	KnX	KnY	KnM	T	C	D	- - - -							
S1				*	*						*	-							
S2				*	*						*	-							
D											*	-							
Notes on operand usage: Please refer to the function specifications table for each device in series for the scope of device usage												DESUB : Continuous execution type				DESUBP : Pulse execution type			
												Flag signal: none							

Explanation

- **S<sub>1</sub>**: minuend. **S<sub>2</sub>**: subtrahend. **D**: difference.
- When the content of the register designated by **S<sub>2</sub>** is subtracted from the content of the register designated by **S<sub>1</sub>**, the difference will be stored in the register designated by **D**; subtraction is performed entirely using binary floating-point numbers.
- **If the source operand S<sub>1</sub> or S<sub>2</sub> designates a constant K or H, the command will transform that constant into a binary floating point number for use in subtraction.**
- **In the situation when S<sub>1</sub> and S<sub>2</sub> designate identical register numbers, if a "continuous execution" command is employed, when conditional contact is On, the register will perform addition once during each scan. Pulse execution type commands (DESUBP) are generally used under ordinary circumstances.**

Example

- When X0=On, a binary floating point number (D1, D0) will be subtracted to a binary floating point number (D3, D2), and the results stored in (D11, D10).

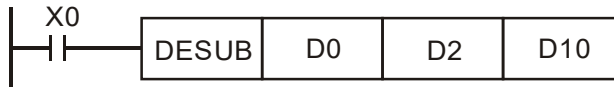

- When X2 =On, the binary floating point number (D1, D0) will be subtracted from K1234 (which has been automatically converted to a binary floating-point number), and the results stored in (D11, D10).

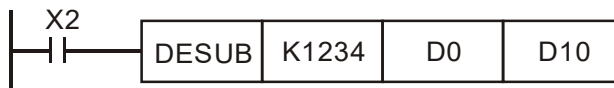



API 122	D	EMUL	P	(S <sub>1</sub> )	(S <sub>2</sub> )	(D)	Multiplication of binary floating point numbers								
Bit device		Word device										16-bit command			
X	Y	M	K	H	KnX	KnY	KnM	T	C	D	-				
S1			*	*						*	-				
S2			*	*						*	-				
D										*	-				
Notes on operand usage: Please refer to the function specifications table for each device in series for the scope of device usage											DEMUL : Continuous execution type    DEMULP : Pulse execution type				
											Flag signal: none				

Explanation

- **S<sub>1</sub>**: multiplicand. **S<sub>2</sub>**: multiplier. **D**: product.
- When the content of the register designated by **S<sub>1</sub>** is multiplied by the content of the register designated by **S<sub>2</sub>**, the product will be stored in the register designated by **D**; multiplication is performed entirely using binary floating-point numbers.
- **If the source operand S<sub>1</sub> or S<sub>2</sub> designates a constant K or H, the command will transform that constant into a binary floating point number for use in multiplication.**
- **In the situation when S<sub>1</sub> and S<sub>2</sub> designate identical register numbers, if a "continuous execution" command is employed, when conditional contact is On, the register will perform multiplication once during each scan. Pulse execution type commands (DEMULP) are generally used under ordinary circumstances.**

Example

- When X1=On, the binary floating point number (D1, D0) will be multiplied by the binary floating point number (D11, D10), and the product will be stored in the register designated by (D21, D20).

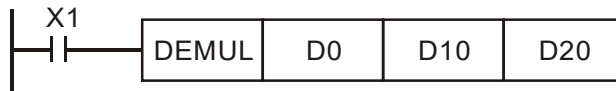

- When X2 =On, the binary floating point number (D1, D0) will be multiplied from K1234 (which has been automatically converted to a binary floating-point number), and the results stored in (D11, D10).

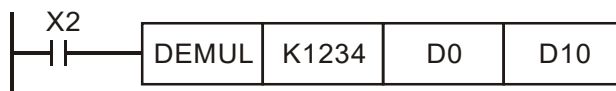

API 123	D	EDIV	P	(S <sub>1</sub> )	(S <sub>2</sub> )	(D)	Division of binary floating point numbers								
	Bit device			Word device								16-bit command			
	X	Y	M	K	H	KnX	KnY	KnM	T	C	D	- - - -			
S1				*	*						*	-			
S2				*	*						*	32-bit command (13 STEP)			
D											*	DEDIV	Continuous execution type	DEDIVP	Pulse execution type
Notes on operand usage: Please refer to the function specifications table for each device in series for the scope of device usage												Flag signal: none			

Explanation

- S<sub>1</sub>: dividend. S<sub>2</sub>: divisor. D: quotient and remainder.
- When the content of the register designated by S<sub>1</sub> is divided by the content of the register designated by S<sub>2</sub>, the quotient will be stored in the register designated by D; division is performed entirely using binary floating-point numbers.
- If the source operand S<sub>1</sub> or S<sub>2</sub> designates a constant K or H, the command will transform that constant into a binary floating point number for use in division.

Example

- When X1=On, the binary floating point number (D1, D0) will be divided by the binary floating point number (D11, D10), and the quotient stored in the register designated by (D21, D20).

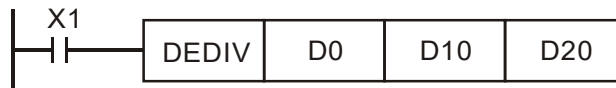

- When X2=On, the binary floating point number (D1, D0) will be divided by K1,234 (which has been automatically converted to a binary floating-point number), and the results stored in (D11, D10).

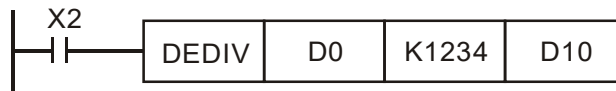

API 124	<b>D</b>	<b>EXP</b>	<b>P</b>	<b>S</b>	<b>D</b>	Binary floating point number obtain exponent								
Bit device			Word device								16-bit command			
X	Y	M	K	H	KnX	KnY	KnM	T	C	D	-	-	-	-
S			*	*						*	32-bit command (9 STEP)			
D										*	DEXP	Continuous execution type	DEXPP	Pulse execution type
Notes on operand usage: Please refer to the function specifications table for each device in series for the scope of device usage											Flag signal: none			

Explanation

- **S**: operation source device. **D**: operation results device.
- Taking  $e = 2.71828$  as a base, **S** is the exponent in the EXP operation.
- $[D + 1, D] = \text{EXP}[S + 1, S]$
- Valid regardless of whether the content of **S** has a positive or negative value. The designated register **D** must have a 32-bit data format. This operation is performed using floating-point numbers, and **S** must therefore be converted to a floating point number.
- Content of operand  $D = e^S$ ;  $e = 2.71828$ , **S** is the designated source data

Example

- When M0 is On, the value of (D1, D0) will be converted to a binary floating point number, which will be stored in register (D11, D10).
- When M1 is On, the EXP operation is performed on the exponent of (D11, D10); its value is a binary floating point number stored in register (D21, D20).

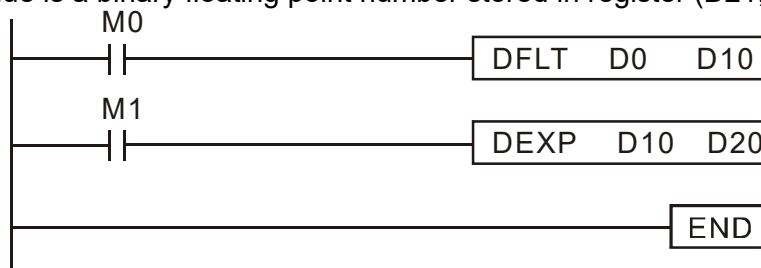

API 125	D	LN	P	(S)	(D)	Binary floating point number obtain logarithm									
	Bit device			Word device								16-bit command			
	X	Y	M	K	H	KnX	KnY	KnM	T	C	D	-	-	-	-
S				*	*										
D											*	32-bit command (9 STEP)			
Notes on operand usage: Please refer to the function specifications table for each device in series for the scope of device usage												DLN	Continuous execution type	DLNP	Pulse execution type
												Flag signal: none			

Explanation

- **S**: operation source device. **D**: operation results device.
- Taking  $e = 2.71828$  as a base, **S** is the exponent in the EXP operation.
- $[D + 1, D] = \text{EXP}[S + 1, S]$
- Valid regardless of whether the content of **S** has a positive or negative value. The designated register D must have a 32-bit data format. This operation is performed using floating-point numbers, and **S** must therefore be converted to a floating point number.
- Content of operand **D** =  $e^S$ ;  $e = 2.71828$ , **S** is the designated source data

Example

- When M0 is On, the value of (D1, D0) will be converted to a binary floating point number, which will be stored in register (D11, D10).
- When M1 is On, the EXP operation is performed on the exponent of (D11, D10); its value is a binary floating point number stored in register (D21, D20).

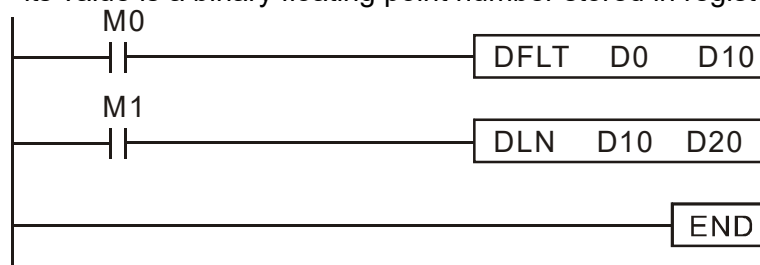

API 127	D	ESQR	P	(S) (D)	Binary floating point number find square root									
Bit device		Word device								16-bit command				
X	Y	M	K	H	KnX	KnY	KnM	T	C	D	-	-	-	-
S			*	*						*	32-bit command (9 STEP)			
D										*	DESQR	Continuous	DESQR	Pulse
Notes on operand usage: Please refer to the function specifications table for each device in series for the scope of device usage											execution type	P	execution type	
											Flag signal: none			

Explanation

- **S**: source device for which square root is desired **D**: result of finding square root.
- When the square root is taken of the content of the register designated by **S**, the result is temporarily stored in the register designated by **D**. Taking square roots is performed entirely using binary floating-point numbers.
- If the source operand **S** refers to a constant K or H, the command will transform that constant into a binary floating point number for use in the operation.

Example

- When X0=On, the square root is taken of the binary floating point number (D1, D0), and the result is stored in the register designated by (D11, D10).

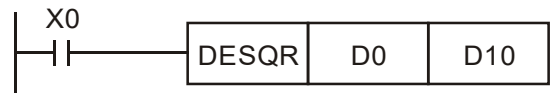

$$\sqrt{(D1 \cdot D0)} \rightarrow (D11 \cdot D10)$$

Binary floating point      Binary floating point

- When X2 =On, the square root is taken of K1,234 (which has been automatically converted to a binary floating-point number), and the results stored in (D11, D10).

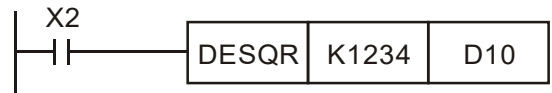

API 129	<b>D</b>	<b>INT</b>	<b>P</b>	<b>(S)</b> <b>(D)</b>	Binary floating point number → BIN whole number transformation
------------	----------	------------	----------	-----------------------	--

	Bit device			Word device								16-bit command (5 STEP)			
	X	Y	M	K	H	KnX	KnY	KnM	T	C	D	INT	Continuous execution type	INTP	Pulse execution type
S															*
D															*

Notes on operand usage:  
Please refer to the function specifications table for each device in series for the scope of device usage

32-bit command (9 STEP)			
DINT	Continuous execution type	DINTP	Pulse execution type

Flag signal: none

Explanation

- **S**: the source device to be transformed. **D**: results of transformation.
- The content of the register designated by **S** is transformed from a binary floating point number format into a BIN whole number, and is temporarily stored in **D**. The BIN whole number floating point number will be discarded.
- The action of this command is the opposite of that of command API 49 (FLT).

Example

- When X0=On, the binary floating point number (D1, D0) is transformed into a BIN whole number, and the result is stored in (D10); the BIN whole number floating point number will be discarded.

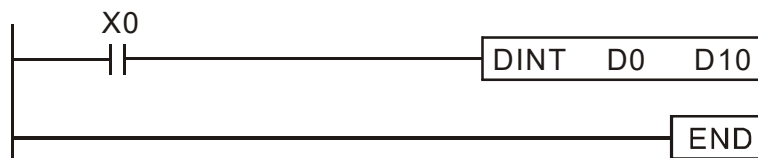

API 130	<b>D</b>	<b>SIN</b>	<b>P</b>	<b>S</b> <b>D</b>	Binary floating point number SIN operation										
	Bit device			Word device								16-bit command			
	X	Y	M	K	H	KnX	KnY	KnM	T	C	D	-			
S				*	*						*	-			
D											*	32-bit command (9 STEP)			
Notes on operand usage: Please refer to the function specifications table for each device in series for the scope of device usage												DSIN	Continuous execution type	DSINP	Pulse execution type
												Flag signal: none			

Explanation

- **S**: the designated source value. **D**: the SIN value result.
- **S** is the designated source in radians.
- The value in radians (RAD) is equal to (angle  $\times \pi/180$ ).
- The SIN obtained from the source value designated by **S** is stored in **D**.

The following figure displays the relationship between the arc and SIN results:

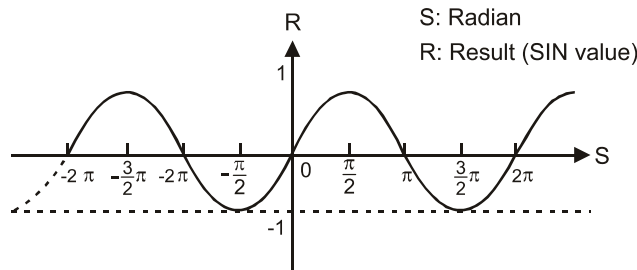

Example

- When X0=On, the SIN value of the designated binary floating point number (D1, D0) in radians (RAD) will be stored in (D11, D10), with the content consisting of a binary floating point number.

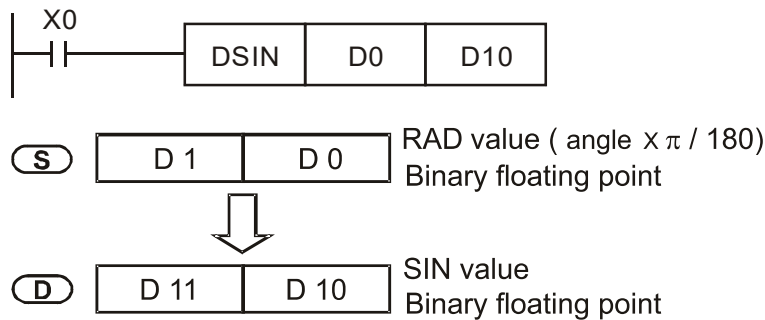

API 131	<b>D</b>	<b>COS</b>	<b>P</b>	<b>(S)</b> <b>(D)</b>	Binary floating point number COS operation									
Bit device		Word device								16-bit command				
X	Y	M	K	H	KnX	KnY	KnM	T	C	D	- - - - -			
S			*	*						*	32-bit command (9 STEP)			
D										*	DCOS	Continuous execution type	DCOSP	Pulse execution type
Notes on operand usage: Please refer to the function specifications table for each device in series for the scope of device usage										Flag signal: none				

Explanation

- **S**: the designated source value. **D**: the COS value result.
- The source designated by **S** can be given as radians or an angle; this is decided by flag M1018.
- When M1018=Off, the operation is in radians mode, where the radians (RAD) value is equal to  $(\text{angle} \times \pi / 180)$ .
- When M1018=On, the operation is in the angle mode, where the angular range is  $0^\circ \leq \text{angle} < 360^\circ$ .
- When calculation results yield 0, M1020=On.
- The COS obtained from the source value designated by **S** is stored in **D**.

The following figure displays the relationship between the arc and SIN results:

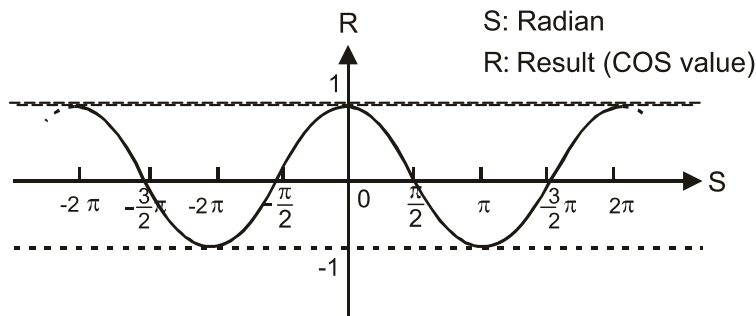

Example

- When X0=On, the COS value of the designated binary floating point number (D1, D0) in radians will be stored in (D11, D10), with the content consisting of a binary floating point number.

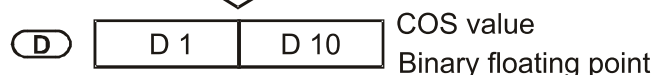
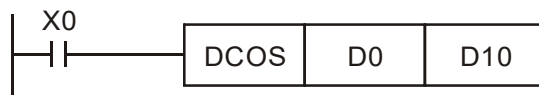



API 132	D	TAN	P	(S) (D)	Binary floating point number TAN operation										
Bit device				Word device								16-bit command			
X	Y	M	K	H	KnX	KnY	KnM	T	C	D	-----				
S			*	*						*	-----				
D										*	32-bit command (9 STEP)				
Notes on operand usage: Please refer to the function specifications table for each device in series for the scope of device usage											DTAN	Continuous execution type	DTANP	Pulse execution type	
											Flag signal: none				

- Explanation**
- **S**: the designated source value. **D**: the TAN value result.
  - The source designated by **S** can be given as radians or an angle; this is decided by flag M1018.
  - When M1018=Off, the operation is in radians mode, where the radians (RAD) value is equal to  $(\text{angle} \times \pi / 180)$ .
  - When M1018=On, the operation is in the angle mode, where the angular range is  $0^\circ \leq \text{angle} < 360^\circ$ .
  - When calculation results yield 0, M1020=On.
  - The TAN obtained from the source value designated by **S** is stored in **D**.

The following figure displays the relationship between the arc and TAN results:

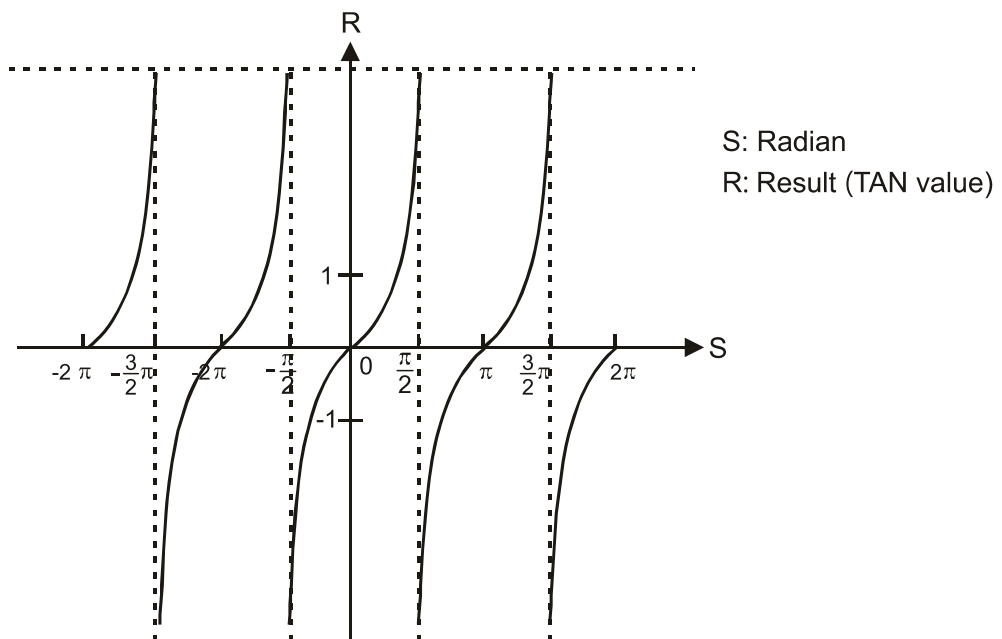

- Example**
- When X0=On, the TAN value of the designated binary floating point number (D1, D0) in radians (RAD) will be stored in (D11, D10), with the content consisting of a binary floating point number.

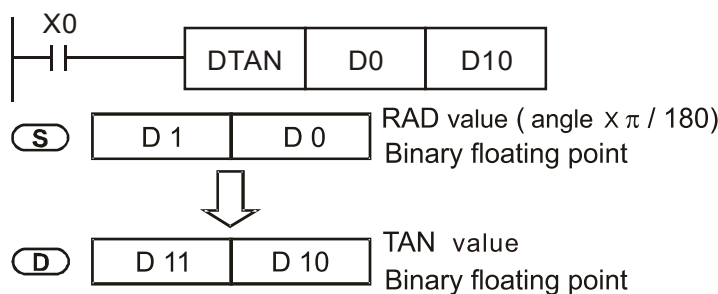

API 133	<b>D</b>	<b>ASIN</b>	<b>P</b>	<b>(S)</b> <b>(D)</b>	Binary floating point number ASIN operation							
Bit device		Word device								16-bit command		
X	Y	M	K	H	KnX	KnY	KnM	T	C	D	- - - - -	
S			*	*						*		
D										*	32-bit command (9 STEP)	
Notes on operand usage: Please refer to the function specifications table for each device in series for the scope of device usage					DASIN		Continuous execution type		DASINP		Pulse execution type	
Flag signal: none												

- Explanation**
- **S**: the designated source (binary floating point number). **D**: the ASIN value result.
  - ASIN value =  $\sin^{-1}$

The figure below shows the relationship between input data and result:

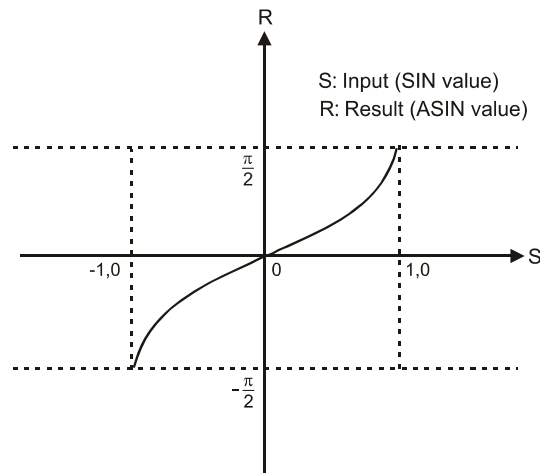

- Example**
- When X0=On, the ASIN value obtained from the designated binary floating point number (D1, D0) will be stored in (D11, D10), with the content consisting of a binary floating point number.

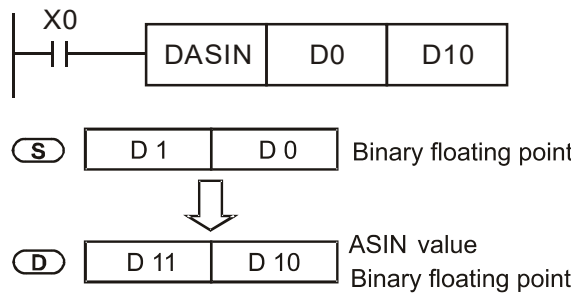

API 134	<b>D</b>	<b>ACOS</b>	<b>P</b>	<b>(S)</b> <b>(D)</b>	Binary floating point number ACOS operation									
Bit device		Word device								16-bit command				
X	Y	M	K	H	KnX	KnY	KnM	T	C	D	-	-	-	-
S			*	*						*	32-bit command (9 STEP)			
D										*	DACOS	Continuous	DACOS	Pulse
Notes on operand usage: Please refer to the function specifications table for each device in series for the scope of device usage											execution type	P	execution type	
											Flag signal: none			

Explanation

- **S**: the designated source (binary floating point number). **D**: the ACOS value result.
- ACOS value =  $\cos^{-1}$

The figure below shows the relationship between input data and result:

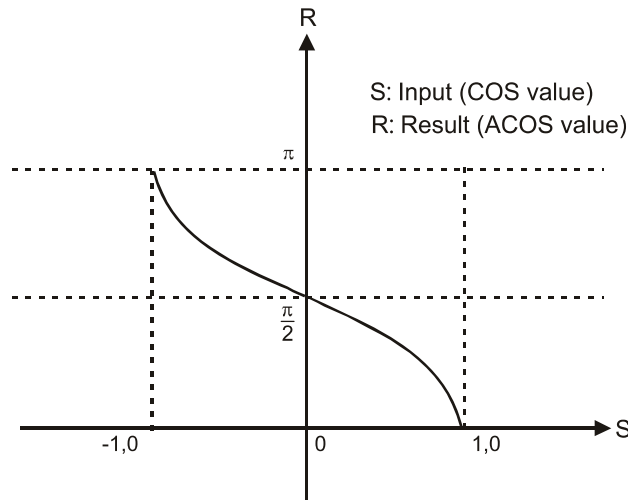

Example

- When X0=On, the ACOS value obtained from the designated binary floating point number (D1, D0) will be stored in (D11, D10), with the content consisting of a binary floating point number.

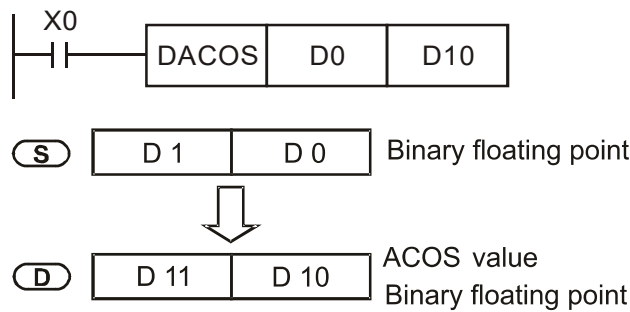

API 135	<b>D</b>	<b>ATAN</b>	<b>P</b>	<b>(S)</b> <b>(D)</b>	Binary floating point number ATAN operation										
Bit device		Word device										16-bit command			
X	Y	M	K	H	KnX	KnY	KnM	T	C	D	-	-	-	-	
S			*	*						*	32-bit command (9 STEP)				
D										*	DATAN	Continuous execution type	DATANP	Pulse execution type	
Notes on operand usage: Please refer to the function specifications table for each device in series for the scope of device usage											Flag signal: none				

Explanation

- **S**: the designated source (binary floating point number). **D**: the ATAN value result.
- ATAN value =  $\tan^{-1}$

The figure below shows the relationship between input data and result:

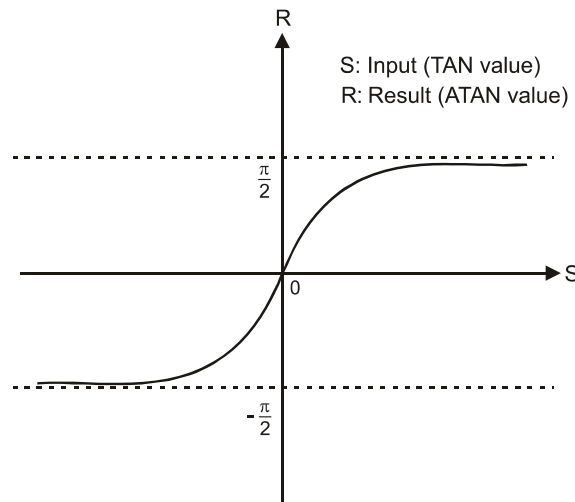

Example

- When X0=On, the TAN value obtained from the designated binary floating point number (D1, D0) will be stored in (D11, D10), with the content consisting of a binary floating point number.

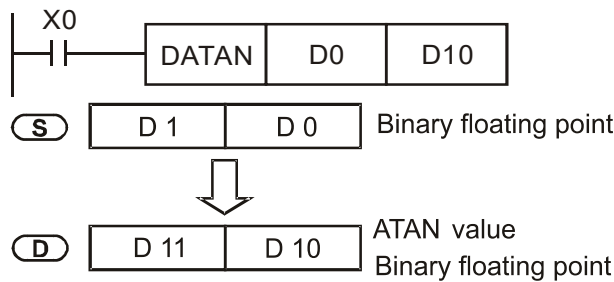

API 136	<b>D</b>	<b>SINH</b>	<b>P</b>	<b>S</b>	<b>D</b>	Binary floating point number SINH operation									
	Bit device			Word device								16-bit command			
	X	Y	M	K	H	KnX	KnY	KnM	T	C	D	- - - -			
S				*	*						*	32-bit command (9 STEP)			
D											*	DSINH : Continuous : DSINH P : Pulse execution type : execution type			
Notes on operand usage: Please refer to the function specifications table for each device in series for the scope of device usage												Flag signal: none			

- Explanation**
- **S**: the designated source (binary floating point number). **D**: the SINH value result.
  - $SINH\ value = (e^s - e^{-s}) / 2$

- Example**
- When X0=On, the SINH value obtained from the designated binary floating point number (D1, D0) will be stored in (D11, D10), with the content consisting of a binary floating point number.

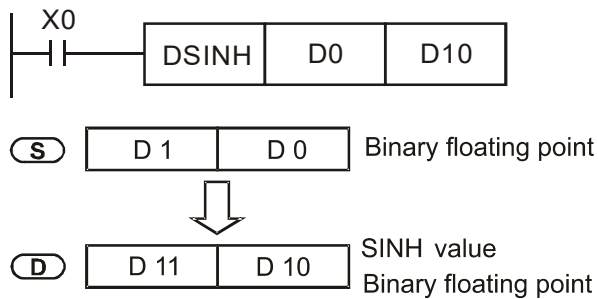

API 137	<b>D</b>	<b>COSH</b>	<b>P</b>	<b>(S) (D)</b>								Binary floating point number COSH operation	
Bit device		Word device										16-bit command	
X	Y	M	K	H	KnX	KnY	KnM	T	C	D	- - - - -		
S			*	*							*	- - - - -	
D											*	32-bit command (9 STEP)	
Notes on operand usage: Please refer to the function specifications table for each device in series for the scope of device usage											DCOSH : Continuous execution type	DCOSH : Pulse execution type	
											Flag signal: none		

Explanation

- **S**: the designated source (binary floating point number). **D**: the COSH value result.
- $\text{COSH value} = (e^s + e^{-s}) / 2$

Example

- When X0=On, the COSH value obtained from the designated binary floating point number (D1, D0) will be stored in (D11, D10), with the content consisting of a binary floating point number.

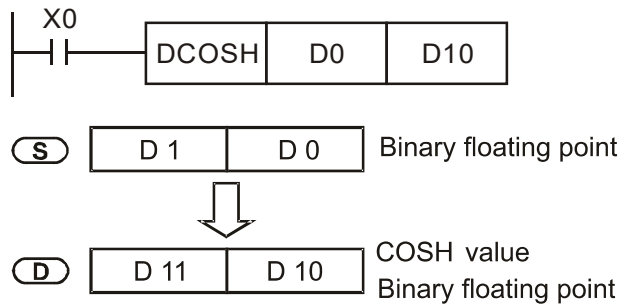

API 138	D	TANH	P	(S)	(D)	Binary floating point number TANH operation								
Bit device			Word device								16-bit command			
X	Y	M	K	H	KnX	KnY	KnM	T	C	D	-	-	-	-
S			*	*						*				
D										*	32-bit command (9 STEP)			
Notes on operand usage: Please refer to the function specifications table for each device in series for the scope of device usage											DTANH	Continuous	DTANH	Pulse
											execution type	P	execution type	
											Flag signal: none			

- Explanation
- **S**: the designated source (binary floating point number). **D**: the TANH value result.
  - $TANH\ value = (e^s - e^{-s}) / (e^s + e^{-s})$

- Example
- When X0=On, the TANH value obtained from the designated binary floating point number (D1, D0) will be stored in (D11, D10), with the content consisting of a binary floating point number.

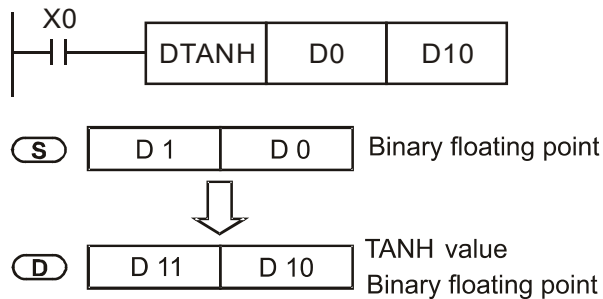

API 147	D	<b>SWAP</b>	P	(S)								Exchange the up/down 8 bits				
		Bit device			Word device							16-bit command (3 STEP)				
		X	Y	M	K	H	KnX	KnY	KnM	T	C	D	SWAP	Continuous execution type	SWAPP	Pulse execution type
S							*	*	*	*	*	*				
Notes on operand usage: none												32-bit command (5 STEP)				
												DSWAP	Continuous execution type	DSWAPP	Pulse execution type	
												Flag signal: none				

Explanation

- (S): The device that going to exchange its up/down 8 bits.
- When using 16-bit command, the upper 8-bit and lower 8-bit exchange.
- When using 32-bit command, the contents of upper 8-bit and lower 8-bit of the 2 registers exchange.
- This command usually uses pulse execution type (SWAPP, DSWAPP)



API 150	<b>MODRW</b>	<b>P</b>	<b>S<sub>1</sub></b>	<b>S<sub>2</sub></b>	<b>S<sub>3</sub></b>	<b>S</b>	<b>n</b>	MODBUS data read/write					
	Bit device		Word device								16-bit command (5 STEP)		
	X	Y	M	K	H	KnX	KnY	KnM	T	C	D	MODRW: Continuous execution type	MODRW: Pulse execution type
S1				*	*						*		
S2				*	*						*		
S3				*	*						*		
S											*		
n				*	*						*		
												32-bit command	
												Flag signal: M1077 M1078 M1079	

Explanation

- S1: online device address. S2: communications function code. S3: address of data to read/write. S: register for data to be read/written is stored. N: length of data to be read/written.
- COM1 must be defined as controlled by the PLC (set Pr.09-31 = -12) before using this command, and the corresponding communications speed and format must also be set (set Pr.09-01 and Pr.09-04). S2: communications function code. Currently only supports the following function code; the remaining function code cannot be executed.

Function	Description
H 02	Input read
H 03	Read word
H 06	Write single word
H 0F	Write multiple coils
H 10	Write single word

- After executing this command, M1077, M1078 and M1079 will be immediately changed to 0.
- As an example, when C2000 must control another converter and PLC, if the converter has a station number of 10 and the PLC has a station number of 20, see the following example:

Control slave device converter

Serial No.	Example	MODRW command				
		S1	S2	S3	S4	n
		Node ID	Function code	Addresses	Register	Length:
1	Reads 4 sets of data comprising the converter slave device parameters Pr.01-00 to Pr.01-03, and saves the read data in D0 to D3	K10	H3	H100	D0	K4
2	Reads 3 sets of data comprising the converter slave device addresses H2100 to H2102, and saves the read data in D5 to D7	K10	H3	H2100	D5	K3
3	Writes 3 sets of data comprising the converter slave device parameters Pr.05-00 to Pr.05-03, and writes the values as D10 to D12	K10	H10	H500	D10	K3
4	Writes 2 sets of data comprising the converter slave device addresses H2000 to H2001, and writes the values as D15 to D16	K10	H10	H2000	D15	K2

## PLC controlling slave device

Serial No.	Example	MODRW command				
		S1	S2	S3	S4	n
		Node ID	Function code	Addresses	Register	Length:
1	Reads 4 sets of data comprising the PLC slave device's X0 to X3 state, and saves the read data in bits 0 to 3 of D0	K20	H2	H400	D0	K4
2	Reads 4 sets of data comprising the PLC slave device's Y0 to Y3 state, and saves the read data in bits 0 to 3 of D1	K20	H2	H500	D1	K4
3	Reads 4 sets of data comprising the PLC slave device's M0 to M3 state, and saves the read data in bits 0 to 3 of D2	K20	H2	H800	D2	K4
4	Reads 4 sets of data comprising the PLC slave device's T0 to T3 state, and saves the read data in bits 0 to 3 of D3	K20	H2	H600	D3	K4
5	Reads 4 sets of data comprising the PLC slave device's C0 to C3 state, and saves the read data in bits 0 to 3 of D4	K20	H2	HE00	D4	K4
6	Reads 4 sets of data comprising the PLC slave device's T0 to T3 count value, and saves the read data of D10 to D13	K20	H3	H600	D10	K4
7	Reads 4 sets of data comprising the PLC slave device's C0 to C3 count value, and saves the read data of D20 to D23	K20	H3	HE00	D20	K4
8	Reads 4 sets of data comprising the PLC slave device's D0 to D3 count value, and saves the read data of D30 to D33	K20	H3	H1000	D30	K4
9	Writes 4 sets of the PLC slave device's Y0 to Y3 state, and writes the values as bits 0 to 3 of D1	K20	HF	H500	D1	K4
10	Writes 4 sets of the PLC slave device's M0 to M3 state, and writes the values as bits 0 to 3 of D2	K20	HF	H800	D2	K4
11	Writes 4 sets of the PLC slave device's T0 to T3 state, and writes the values as bits 0 to 3 of D3	K20	HF	H600	D3	K4
12	Writes 4 sets of the PLC slave device's C0 to C3 state, and writes the values as bits 0 to 3 of D4	K20	HF	HE00	D4	K4
13	Writes 4 sets of the PLC slave device's T0 to T3 state, and writes the values of D10 to D13	K20	H10	H600	D10	K4
14	Writes 4 sets of the PLC slave device's C0 to C3 state, and writes the values of D20 to D23	K20	H10	HE00	D20	K4
15	Writes 4 sets of the PLC slave device's D0 to D3 state, and writes the values of D30 to D33	K20	H10	H1000	D30	K4

Example

- Will trigger M0 On when the PLC begins to operate, and sends instruction to execute one MODRW command.
- After receiving the slave device's response, if the command is correct, it will execute one ROL command, which will cause M1 to be On.
- After receiving the slave device's response, will trigger M50 = 1 after a delay of 10 PLC scanning cycles, and then execute one MODRW command.
- After again receiving the slave device's response, if the command is correct, it will execute one ROL command, and M2 will change to On at this time (and M2 can be defined as a repeat of M); K4M0 will change to K1, and only M0 will remain 1. Transmission can proceed in a continuous cycle. If you wish to add a command, merely add the desired command in the empty frame, and change repeat M to Mn+1.

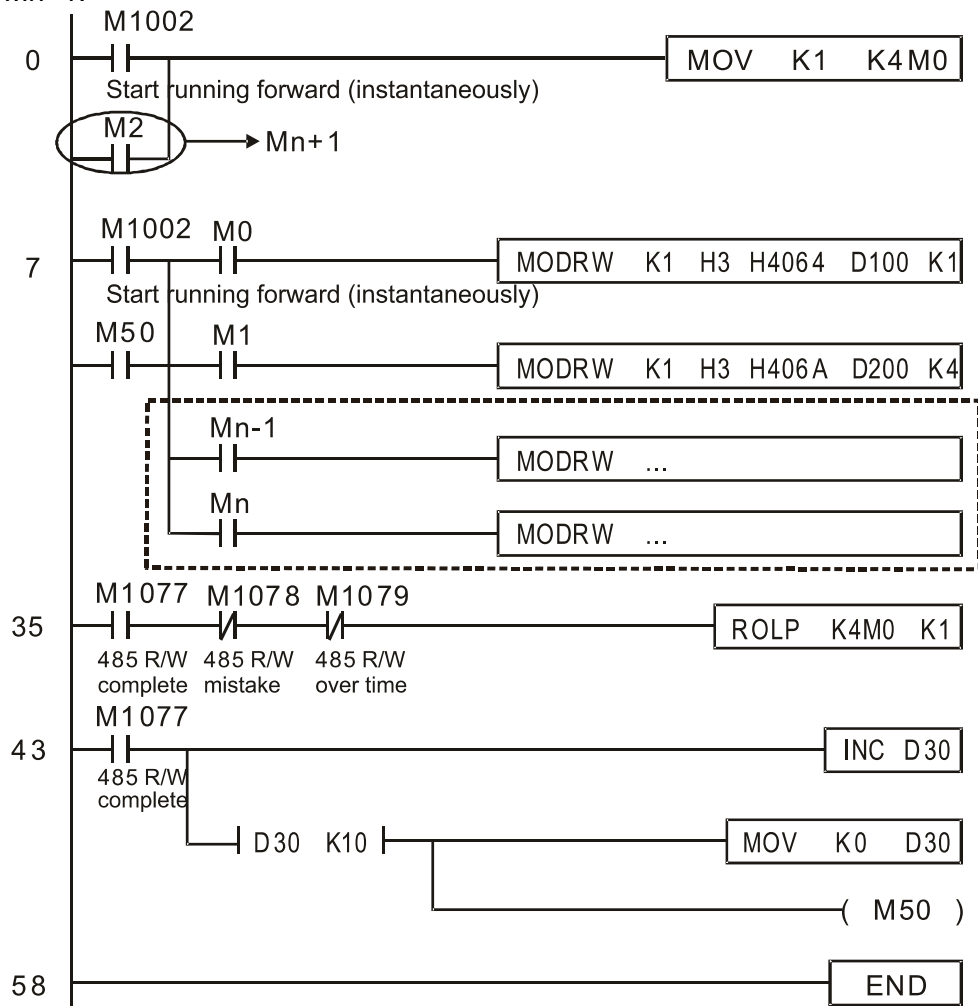

API 160	<b>TCMP</b>	<b>P</b>	<span style="border: 1px solid black; border-radius: 50%; padding: 2px;">S<sub>1</sub></span> <span style="border: 1px solid black; border-radius: 50%; padding: 2px;">S<sub>2</sub></span> <span style="border: 1px solid black; border-radius: 50%; padding: 2px;">S<sub>3</sub></span> <span style="border: 1px solid black; border-radius: 50%; padding: 2px;">S</span> <span style="border: 1px solid black; border-radius: 50%; padding: 2px;">D</span>	Comparison of calendar data
------------	-------------	----------	---	-----------------------------

	Bit device			Word device								16-bit command (11 STEP)			
	X	Y	M	K	H	KnX	KnY	KnM	T	C	D	TCMP	Continuous execution type	TCMPP	Pulse execution type
S1				*	*	*	*	*	*	*	*				
S2				*	*	*	*	*	*	*	*				
S3				*	*	*	*	*	*	*	*				
S									*	*	*				
D		*	*												

Notes on operand usage:  
Please refer to the function specifications table for each device in series for the scope of device usage

Flag signal: none

Explanation

- **S<sub>1</sub>**: Sets the hours of the comparison time, setting range is "K0–K23." **S<sub>2</sub>**: Sets the minutes of the comparison time, setting range is "K0–K59." **S<sub>3</sub>**: Sets the seconds of the comparison time, setting range is "K0–K59." **S**: current calendar time. **D**: Results of comparison.
- Compares the time in hours, minutes, and seconds set in **S<sub>1</sub>–S<sub>3</sub>** with the current calendar time in hours, minutes, and seconds, with the results of comparison expressed in **D**.
- **S** The hour content of the current calendar time is "K0–K23." **S** + 1 comprises the minutes of the current calendar time, and consists of "K0–K59." **S** + 2 comprises the seconds of the current calendar time, and consists of "K0–K59."
- The current calendar time designated by **S** is usually compared using the TCMP command after using the TRD command to read the current calendar time. If the content value of **S** exceeds the range, this is considered an operating error, the command will not execute, and M1068=On.

Example

- When X10=On, the command will execute, and the current calendar time in D20–D22 will be compared with the preset value of 12:20:45; the results will be displayed in M10–M12. When X10 On→Off, the command will not be executed, but the On/Off status prior to M10–M12 will be maintained.
- If results in the form of  $\geq$ ,  $\leq$ , or  $\neq$  are needed, they can be obtained by series and parallel connection of M10–M12.

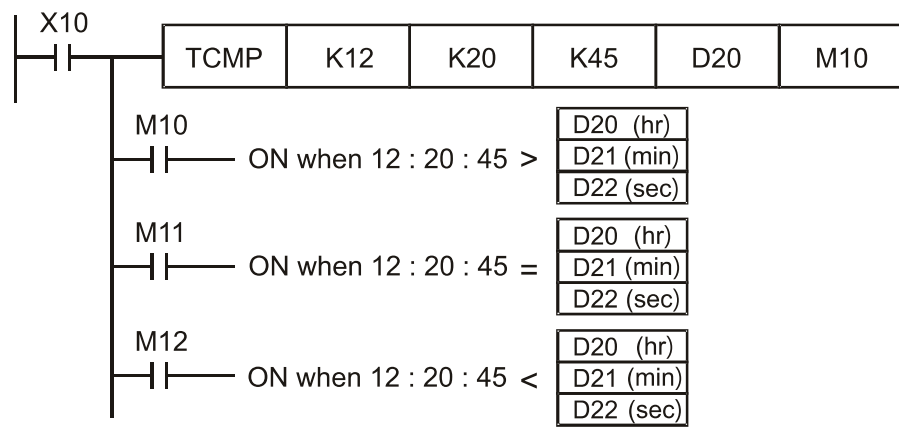

API 161	TZCP		P									Comparison of calendar data			
Bit device			Word device									16-bit command (9 STEP)			
X	Y	M	K	H	KnX	KnY	KnM	T	C	D	TZCP	Continuous execution type	TZCPP	Pulse execution type	
S1								*	*	*					
S2								*	*	*					
S								*	*	*					
D	*	*													
Notes on operand usage: Please refer to the function specifications table for each device in series for the scope of device usage											Flag signal: none				

- Explanation**
- **S<sub>1</sub>**: Sets the lower limit of the comparison time. **S<sub>2</sub>**: Sets the upper limit of the comparison time. **S**: current calendar time. **D**: Results of comparison.
  - Performs range comparison by comparing the hours, minutes, and seconds of the current calendar time designated by **S** with the lower limit of the comparison time set as **S<sub>1</sub>** and the upper limit of the comparison time set as **S<sub>2</sub>**, and expresses the results of comparison in **D**.
  - **S<sub>1</sub>、S<sub>1</sub> + 1、S<sub>1</sub> + 2**: Sets the hours, minutes, and seconds of the lower limit of the comparison time.
  - **S<sub>2</sub>、S<sub>2</sub> + 1、S<sub>2</sub> + 2**: Sets the hours, minutes, and seconds of the upper limit of the comparison time.
  - **S、S + 1、S + 2**: The hours, minutes, and seconds of the current calendar time
  - The D0 designated by the **S** listed in this program is usually obtained by comparison using the TZCP command after using the TRD command in advance to read the current calendar time. If the value of **S<sub>1</sub>**, **S<sub>2</sub>**, or **S** exceeds the range, this is considered an operating error, the command will not execute, and M1068=On.
  - When the current time **S** is less than the lower limit value **S<sub>1</sub>** and **S** is less than the upper limit value **S<sub>2</sub>**, **D** will be On. When the current time **S** is greater than the lower limit value **S<sub>1</sub>** and **S** is greater than the upper limit value **S<sub>2</sub>**, **D + 2** will be On; **D + 1** will be On under other conditions.

- Example**
- When X10=On, the TZCP command executes, and one of M10–M12 will be On. When X10=Off, the TZCP command will not execute, and M10–M12 will remain in the X10=Off state.

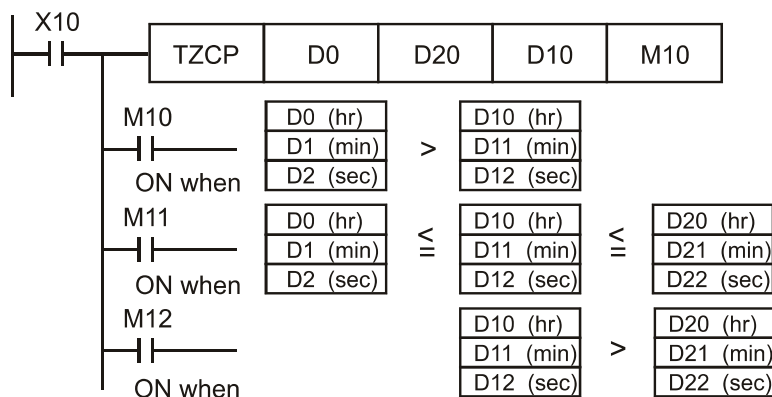

API 162	<b>TADD</b>		<b>P</b>	<b>(S1) (S2) (D)</b>								Calendar data addition			
Bit device			Word device									16-bit command (7 STEP)			
X	Y	M	K	H	KnX	KnY	KnM	T	C	D	TADD	Continuous execution type	TADDP	Pulse execution type	
S1								*	*	*					
S2								*	*	*					
D								*	*	*	32-bit command				
Notes on operand usage: Please refer to the function specifications table for each device in series for the scope of device usage											<ul style="list-style-type: none"> <li>Flag signal: M1020 Zero flag M1022 Carry flag M1068 Calendar error</li> </ul>				

Explanation

- **S1**: time addend. **S2**: time augend. **D**: time sum.
- The calendar data in hours, minutes, and seconds designated by **S2** is added to the calendar data in hours, minutes, and seconds designated by **S1**, and the result is stored as hours, minutes, and seconds in the register designated by **D**.
- If the value of **S1** or **S2** exceeds the range, this is considered an operating error, the command will not execute, M1067, M1068=On, and D1067 will record the error code 0E1A(HEX).
- If the results of addition are greater than or equal to 24 hours, carry flag M1022=On, and **D** will display the results of addition minus 24 hours.
- If the results of addition are equal to 0 (0 hours, 0 minutes, 0 seconds), zero flag M1020=On.

Example

- When X10=On, the TADD command will be executed, and the calendar data in hours, minutes, and seconds designated by D0 to D2 will be added to the calendar data in hours, minutes, and seconds designated by D10 to D12, and the results are stored as a total number of hours, minutes, and seconds in the registers designated by D20 to D22.

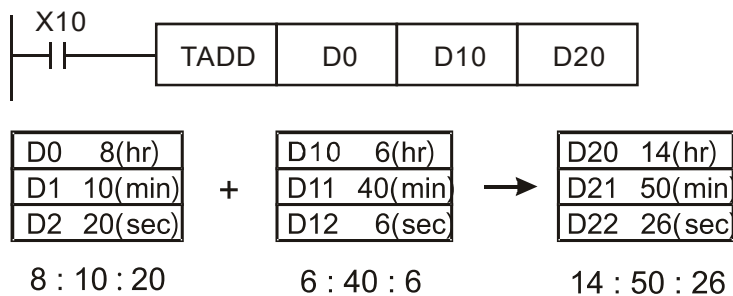

API 163	TSUB		P	<span style="border: 1px solid black; border-radius: 50%; padding: 2px;">S<sub>1</sub></span> <span style="border: 1px solid black; border-radius: 50%; padding: 2px;">S<sub>2</sub></span> <span style="border: 1px solid black; border-radius: 50%; padding: 2px;">D</span>								Calendar data subtraction			
Bit device			Word device									16-bit command (7 STEP)			
X	Y	M	K	H	KnX	KnY	KnM	T	C	D	TSUB	Continuous execution type	TSUBP	Pulse execution type	
S1								*	*	*	32-bit command				
S2								*	*	*	-				
D								*	*	*	-				
Notes on operand usage: Please refer to the function specifications table for each device in series for the scope of device usage											<ul style="list-style-type: none"> <li>Flag signal: M1020 Zero flag M1022 Carry flag M1068 Calendar error</li> </ul>				

Explanation

- **S<sub>1</sub>**: time minuend. **S<sub>2</sub>**: time augend. **D**: time sum.
- Subtracts the calendar data in hours, minutes, and seconds designated by **S<sub>2</sub>** from the calendar data in hours, minutes, and seconds designated by **S<sub>1</sub>**, and the result is temporarily stored as hours, minutes, and seconds in the register designated by **D**.
- If the value of **S<sub>1</sub>** or **S<sub>2</sub>** exceeds the range, this is considered an operating error, the command will not execute, M1067, M1068=On, and D1067 will record the error code 0E1A(HEX).
- If subtraction results in a negative number, borrow flag M1021=On, and the result of that negative number plus 24 hours will be displayed in the register designated by **D**.
- If the results of subtraction are equal to 0 (0 hours, 0 minutes, 0 seconds), zero flag M1020=On.

Example

- When X10=On, the TADD command will be executed, and the calendar data in hours, minutes, and seconds designated by D10 to D12 will be subtracted from the calendar data in hours, minutes, and seconds designated by D0 to D2, and the results are stored as a total number of hours, minutes, and seconds in the registers designated by D20 to D22.

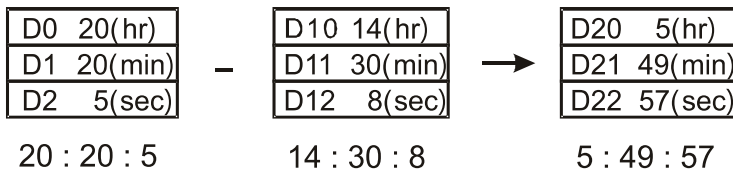
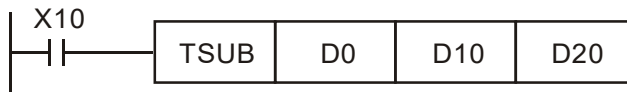

API 166	TRD	P	<b>D</b>	Calendar data read											
Bit device			Word device									16-bit command (3 STEP)			
X	Y	M	K	H	KnX	KnY	KnM	T	C	D	TRD	Continuous execution type	TRDP	Pulse execution type	
D								*	*	*	32-bit command				
Notes on operand usage: Please refer to the function specifications table for each device in series for the scope of device usage											• Flag signal: none				

Explanation

- **S<sub>1</sub>**: time minuend. **S<sub>2</sub>**: time augend. **D**: time sum.
- **D**: device used to store the current calendar time after reading.
- The EH/EH2/SV/EH3/SV2/SA/SX/SC main units have a built-in calendar clock, and the clock provides seven sets of data comprising year, week, month, day, hour, minute, and second stored in D1063 to D1069. The TRD command function allows program designers to directly read the current calendar time into the designated seven registers.
- D1063 only reads the two right digits of the Western calendar year.

Example

- When X0=On, the current calendar time is read into the designated registers D0 to D6.
- In D1064, 1 indicates Monday, 2 indicates Tuesday, and so on, with 7 indicating Sunday.

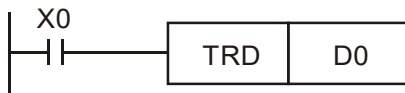

Special D	Item	Content		General D	Item
D1063	Year (Western)	00–99	→	D0	Year (Western)
D1064	Weeks	1–7	→	D1	Weeks
D1065	Month	1–12	→	D2	Month
D1066	Day	1–31	→	D3	Day
D1067	Hour	0–23	→	D4	Hour
D1068	Minute	0–59	→	D5	Minute
D1069	Second	0–59	→	D6	Second



API 170	D	GRY	P	(S) (D)	BIN→GRAY code transformation									
Bit device			Word device								16-bit command (5 STEP)			
X	Y	M	K	H	KnX	KnY	KnM	T	C	D	GRY	Continuous execution type	GRYP	Pulse execution type
S			*	*	*	*	*	*	*	*				
D						*	*	*	*	*				
Notes on operand usage: Please refer to the function specifications table for each device in series for the scope of device usage											32-bit command (9 STEP)			
											DGRY	Continuous execution type	DGRYP	Pulse execution type
• Flag signal: none														

- Explanation**
- **S**: source device. **D**: device storing GRAY code.
  - Transforms the content value (BIN value) of the device designated by **S** to GRAY code, which is stored in the device designated by **D**.
  - The valid range of **S** is as shown below; if this range is exceeded, it will be considered an error, and the command will not execute.

16-bit command: 0–32,767

- 32-bit command: 0–2,147,483,647

- Example**
- When X0=On, the constant K6513 will be transformed to GRAY code and stored in D0.

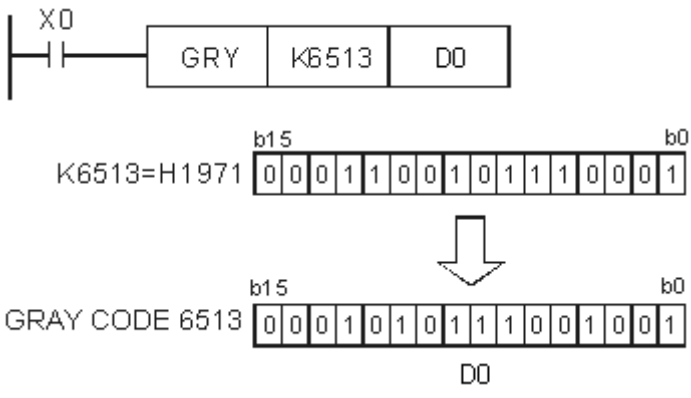

API 171	D	GBIN	P	(S) (D)	GRAY code → BIN transformation										
Bit device		Word device										16-bit command (5 STEP)			
X	Y	M	K	H	KnX	KnY	KnM	T	C	D	GBIN	Continuous execution type	GBINP	Pulse execution type	
S			*	*	*	*	*	*	*	*					
D						*	*	*	*	*					
Notes on operand usage: Please refer to the function specifications table for each device in series for the scope of device usage											32-bit command (9 STEP)				
											DGBIN	Continuous execution type	DGBINP	Pulse execution type	
											• Flag signal: none				

Explanation

- **S**: source device used to store GRAY code. **D**: device used to store BIN value after transformation.
- The GRAY code corresponding to the value of the device designated by **S** is transformed into a BIN value, which is stored in the device designated by **D**.
- This command will transform the value of the absolute position encoder connected with the PLC's input and (this encoder usually has an output value in the form of GRAY code) into a BIN value, which is stored in the designated register.
- The valid range of **S** is as shown below; if this range is exceeded, it will be considered an error, and the command will not execute.

16-bit command: 0–32,767

- 32-bit command: 0–2,147,483,647

Example

- When X20=On, the GRAY code of the absolute position encoder connected with input points X0 to X17 will be transformed into BIN value and stored in D10.

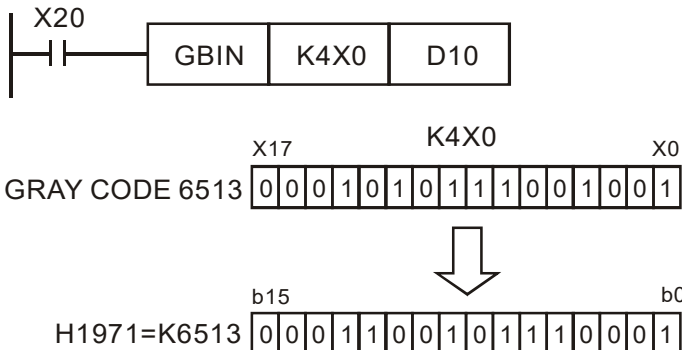

API 215- 217	D	LD#	(S1)	(S2)	Contact form logical operation LD#										
Bit device			Word device									16-bit command (5 STEP)			
X	Y	M	K	H	KnX	KnY	KnM	T	C	D	LD#	Continuous execution type	-	-	
S1			*	*	*	*	*	*	*	*					
S2			*	*	*	*	*	*	*	*					
Notes on operand usage: # : & 、   、 ^ Please refer to the function specifications table for each device in series for the range of device usage											32-bit command (9 STEP)				
											DLD#	Continuous execution type	-	-	
Flag signal: none															

Explanation

- **S<sub>1</sub>**: data source device 1. **S<sub>2</sub>**: data source device 2.
- This command performs comparison of the content of **S<sub>1</sub>** and **S<sub>2</sub>**; when the result of comparison is not 0, this command will be activated, but this command will not be activated when the result of comparison is 0.
- The LD#This command can be used while directly connected with the busbar

API No.	16-bit commands	32-bit commands	Conditions for activation			Conditions for inactivation		
215	LD&	DLD&	<b>S<sub>1</sub></b>	&	<b>S<sub>2</sub></b> ≠ 0	<b>S<sub>1</sub></b>	&	<b>S<sub>2</sub></b> = 0
216	LD	DLD	<b>S<sub>1</sub></b>		<b>S<sub>2</sub></b> ≠ 0	<b>S<sub>1</sub></b>		<b>S<sub>2</sub></b> = 0
217	LD^	DLD^	<b>S<sub>1</sub></b>	^	<b>S<sub>2</sub></b> ≠ 0	<b>S<sub>1</sub></b>	^	<b>S<sub>2</sub></b> = 0

- &: logical AND operation.
- |: logical OR operation.
- ^: logical XOR operation.

Example

- When the content of C0 and C10 is subjected to the logical AND operation, and the result is not equal to 0, Y10=On.
- When the content of D200 and D300 is subjected to the logical OR operation, and the result is not equal to 0, and X1=On, Y11=On and remains in that state.

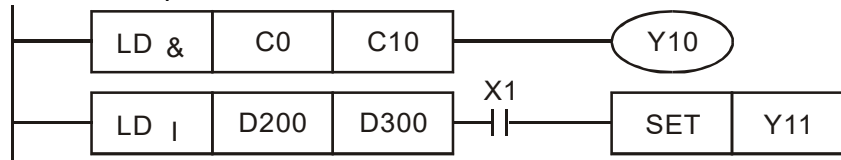

API 218– 220	<b>D</b>	<b>AND#</b>	(S1) (S2)	Contact form logical operation AND#											
Bit device			Word device									16-bit command (5 STEP)			
X	Y	M	K	H	KnX	KnY	KnM	T	C	D	AND#	Continuous execution type	—	—	
S1			*	*	*	*	*	*	*	*	*				
S2			*	*	*	*	*	*	*	*	*				
Notes on operand usage: # : & 、   、 ^ Please refer to the function specifications table for each device in series for the scope of device usage											32-bit command (9 STEP)				
											DAND#	Continuous execution type	—	—	
											Flag signal: none				

Explanation

- **S<sub>1</sub>**: data source device 1. **S<sub>2</sub>**: data source device 2.
- This command performs comparison of the content of **S<sub>1</sub>** and **S<sub>2</sub>**; when the result of comparison is not 0, this command will be activated, but this command will not be activated when the result of comparison is 0.
- The AND# command is an operation command in series with the contact.

API No.	16-bit commands	32-bit commands	Conditions for activation		Conditions for inactivation		
218	AND&	DAND&	<b>S<sub>1</sub></b>	& <b>S<sub>2</sub></b> ≠ 0	<b>S<sub>1</sub></b>	& <b>S<sub>2</sub></b>	= 0
219	AND	DAND	<b>S<sub>1</sub></b>	<b>S<sub>2</sub></b> ≠ 0	<b>S<sub>1</sub></b>	<b>S<sub>2</sub></b>	= 0
220	AND^	DAND^	<b>S<sub>1</sub></b>	^ <b>S<sub>2</sub></b> ≠ 0	<b>S<sub>1</sub></b>	^ <b>S<sub>2</sub></b>	= 0

- &: logical AND operation.
- |: logical OR operation.
- ^: logical XOR operation.

Example

- When X0=On and the content of C0 and C10 is subjected to the logical AND operation, and the result is not equal to 0, Y10=On.
- When X1=Off and D10 and D0 is subjected to the logical OR operation, and the result is not equal to 0, Y11=On and remains in that state.
- When X2 =On and the content of the 32-bit register D200 (D201) and 32-bit register D100 (D101) is subjected to the logical XOR operation, and the result is not equal to 0 or M3=On, M50=On.

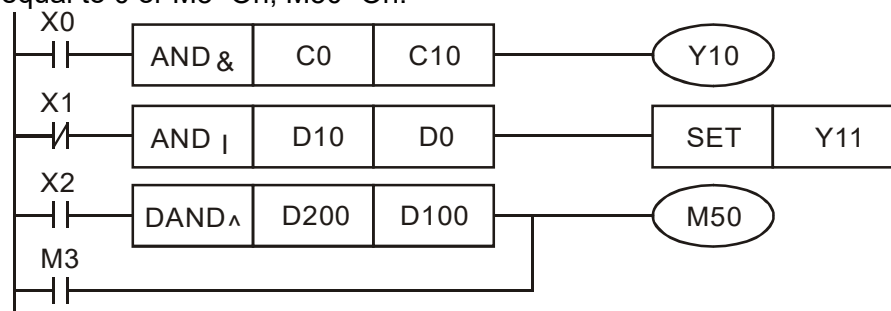

API 221– 223	<b>D</b>	<b>OR#</b>	(S1) (S2)	Contact form logical operation OR#										
Bit device			Word device								16-bit command (5 STEP)			
X	Y	M	K	H	KnX	KnY	KnM	T	C	D	OR#	Continuous execution type	—	—
S1			*	*	*	*	*	*	*	*				
S2			*	*	*	*	*	*	*	*				
Notes on operand usage: # : & 、   、 ^											32-bit command (9 STEP)			
Please refer to the function specifications table for each device in series for the scope of device usage											DOR#	Continuous execution type	—	—
Flag signal: none														

- Explanation**
- **S<sub>1</sub>**: data source device 1. **S<sub>2</sub>**: data source device 2.
  - This command performs comparison of the content of **S<sub>1</sub>** and **S<sub>2</sub>**; when the result of comparison is not 0, this command will be activated, but this command will not be activated when the result of comparison is 0.
  - The OR# command is an operation command in series with the contact.

API No.	16-bit commands	32-bit commands	Conditions for activation		Conditions for inactivation		
221	OR&	DOR&	<b>S<sub>1</sub></b>	& <b>S<sub>2</sub></b> ≠ 0	<b>S<sub>1</sub></b>	& <b>S<sub>2</sub></b>	= 0
222	OR	DOR	<b>S<sub>1</sub></b>	<b>S<sub>2</sub></b> ≠ 0	<b>S<sub>1</sub></b>	<b>S<sub>2</sub></b>	= 0
223	OR^	DOR^	<b>S<sub>1</sub></b>	^ <b>S<sub>2</sub></b> ≠ 0	<b>S<sub>1</sub></b>	^ <b>S<sub>2</sub></b>	= 0

- &: logical AND operation.
- |: logical OR operation.
- ^: logical XOR operation.

- Example**
- When X1=On or the content of C0 and C10 is subjected to the logical AND operation, and the result is not equal to 0, Y0=On.
  - When X2 and M30 are both equal to On, or the content of 32-bit register D10 (D11) and 32-bit register D20 (D21) is subjected to the logical OR operation, and the result is not equal to 0, or the content of the 32-bit counter C235 and the 32-bit register D200 (D201) is subjected to the logical XOR operation, and the result is not equal to 0, M60=On.

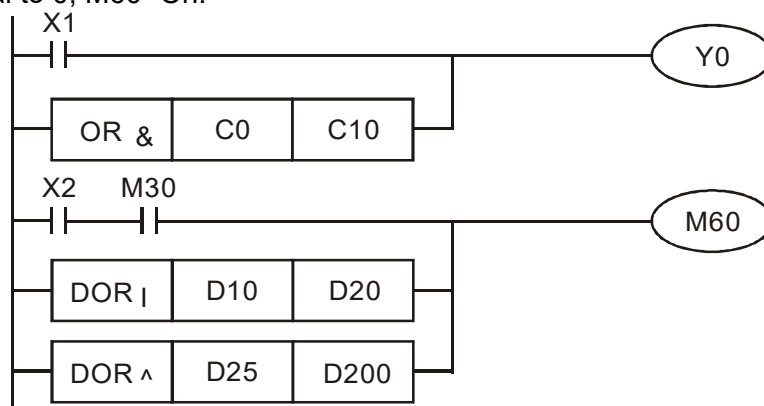

API 224- 230	<b>D</b>	<b>LD※</b>	(S1) (S2)	Contact form compare LD*											
Bit device		Word device										16-bit command (5 STEP)			
	X	Y	M	K	H	KnX	KnY	KnM	T	C	D	LD※	Continuous execution type	—	—
S1				*	*	*	*	*	*	*	*				
S2				*	*	*	*	*	*	*	*				
Notes on operand usage: ※ : = > < <> ≤ ≥												32-bit command (9 STEP)			
Please refer to the function specifications table for each device in series for the scope of device usage												DLD※	Continuous execution type	—	—
Flag signal: none															

Explanation

- **S<sub>1</sub>**: data source device 1. **S<sub>2</sub>**: data source device 2.
- This command compares the content of **S<sub>1</sub>** and **S<sub>2</sub>**. Taking API 224 (LD=) as an example, this command will be activated when the result of comparison is "equal," and will not be activated when the result is "unequal."
- The LD\* can be used while directly connected with the busbar

API No.	16-bit commands	32-bit commands	Conditions for activation	Conditions for inactivation
224	LD=	DLD=	<b>S<sub>1</sub> = S<sub>2</sub></b>	<b>S<sub>1</sub> ≠ S<sub>2</sub></b>
225	LD>	DLD>	<b>S<sub>1</sub> &gt; S<sub>2</sub></b>	<b>S<sub>1</sub> ≤ S<sub>2</sub></b>
226	LD<	DLD<	<b>S<sub>1</sub> &lt; S<sub>2</sub></b>	<b>S<sub>1</sub> ≥ S<sub>2</sub></b>
228	LD<>	DLD<>	<b>S<sub>1</sub> ≠ S<sub>2</sub></b>	<b>S<sub>1</sub> = S<sub>2</sub></b>
229	LD≤	DLD≤	<b>S<sub>1</sub> ≤ S<sub>2</sub></b>	<b>S<sub>1</sub> &gt; S<sub>2</sub></b>
230	LD≥	DLD≥	<b>S<sub>1</sub> ≥ S<sub>2</sub></b>	<b>S<sub>1</sub> &lt; S<sub>2</sub></b>

Example

- When the content of C10 is equal to K200, Y10=On.
- When the content of D200 is greater than K-30, and X1=On, Y11=On and remains in that state.

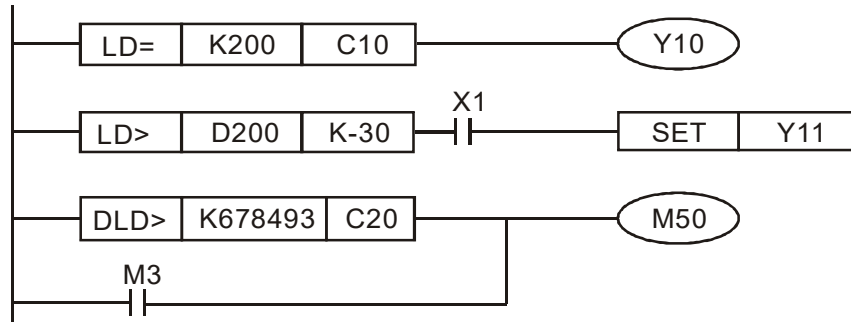

API 232- 238	<b>D</b>	<b>AND※</b>	(S1) (S2)	Contact form compare AND*											
Bit device		Word device										16-bit command (5 STEP)			
X	Y	M	K	H	KnX	KnY	KnM	T	C	D	AND※	Continuous execution type	—	—	
S1			*	*	*	*	*	*	*	*	*				
S2			*	*	*	*	*	*	*	*	*				
Notes on operand usage: ※ : =、>、<、<>、≤、≥											32-bit command (9 STEP)				
Please refer to the function specifications table for each device in series for the scope of device usage											DAND※	Continuous execution type	—	—	
Flag signal: none															

Explanation

- **S<sub>1</sub>**: data source device 1. **S<sub>2</sub>**: data source device 2.
- This command compares the content of **S<sub>1</sub>** and **S<sub>2</sub>**. Taking API 232 (AND=) as an example, when the result of comparison is equal, this command will be activated; when the result of comparison is unequal, this command will not be activated.
- The AND\* command is a comparison command in series with a contact.

API No.	16-bit commands	32-bit commands	Conditions for activation	Conditions for inactivation
232	AND=	DAND=	<b>S<sub>1</sub> = S<sub>2</sub></b>	<b>S<sub>1</sub> ≠ S<sub>2</sub></b>
233	AND>	DAND>	<b>S<sub>1</sub> &gt; S<sub>2</sub></b>	<b>S<sub>1</sub> ≤ S<sub>2</sub></b>
234	AND<	DAND<	<b>S<sub>1</sub> &lt; S<sub>2</sub></b>	<b>S<sub>1</sub> ≥ S<sub>2</sub></b>
236	AND<>	DAND<>	<b>S<sub>1</sub> ≠ S<sub>2</sub></b>	<b>S<sub>1</sub> = S<sub>2</sub></b>
237	AND<=	DAND<=	<b>S<sub>1</sub> ≤ S<sub>2</sub></b>	<b>S<sub>1</sub> &gt; S<sub>2</sub></b>
238	AND>=	DAND>=	<b>S<sub>1</sub> ≥ S<sub>2</sub></b>	<b>S<sub>1</sub> &lt; S<sub>2</sub></b>

Example

- When X0=On and the current value of C10 is also equal to K200, Y10=On.
- When X1=Off and the content of register D0 is not equal to K-10, Y11=On and remains in that state.
- When X2 =On and the content of the 32-bit register D0 (D11) is less than 678,493, or M3=On, M50=On.

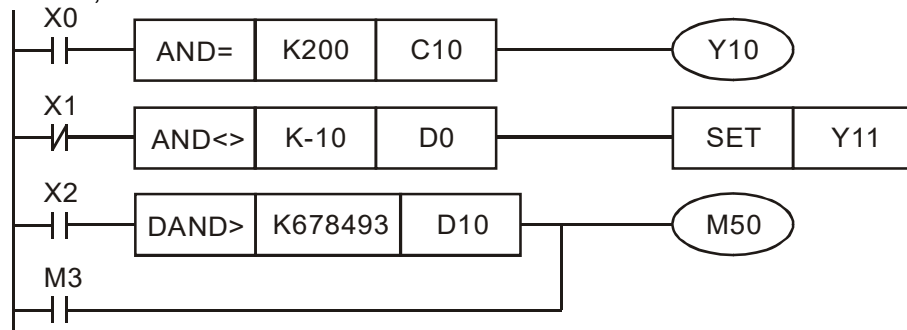

API 240– 246	D	OR※	(S1)	(S2)	Contact form compare OR*										
Bit device		Word device										16-bit command (5 STEP)			
X	Y	M	K	H	KnX	KnY	KnM	T	C	D	OR※	Continuous execution type	—	—	
S1			*	*	*	*	*	*	*	*	*				
S2			*	*	*	*	*	*	*	*	*				
Notes on operand usage: ※ : = , > , < , <> , ≤ , ≥											32-bit command (9 STEP)				
Please refer to the function specifications table for each device in series for the scope of device usage											DOR※	Continuous execution type	—	—	
Flag signal: none															

Explanation

- **S<sub>1</sub>**: data source device 1. **S<sub>2</sub>**: data source device 2.
- This command compares the content of **S<sub>1</sub>** and **S<sub>2</sub>**. Taking API 240 (OR=) as an example, when the result of comparison is equal, this command will be activated; when the result of comparison is unequal, this command will not be activated.
- The OR\* command is a compare command in parallel with a contact.

API No.	16-bit commands	32-bit commands	Conditions for activation	Conditions for inactivation
240	OR=	DOR=	<b>S<sub>1</sub> = S<sub>2</sub></b>	<b>S<sub>1</sub> ≠ S<sub>2</sub></b>
241	OR>	DOR>	<b>S<sub>1</sub> &gt; S<sub>2</sub></b>	<b>S<sub>1</sub> ≤ S<sub>2</sub></b>
242	OR<	DOR<	<b>S<sub>1</sub> &lt; S<sub>2</sub></b>	<b>S<sub>1</sub> ≥ S<sub>2</sub></b>
244	OR<>	DOR<>	<b>S<sub>1</sub> ≠ S<sub>2</sub></b>	<b>S<sub>1</sub> = S<sub>2</sub></b>
245	OR≤	DOR≤	<b>S<sub>1</sub> ≤ S<sub>2</sub></b>	<b>S<sub>1</sub> &gt; S<sub>2</sub></b>
246	OR≥	DOR≥	<b>S<sub>1</sub> ≥ S<sub>2</sub></b>	<b>S<sub>1</sub> &lt; S<sub>2</sub></b>

Example

- When X0=On and the current value of C10 is also equal to K200, Y10=On.
- When X1=Off and the content of register D0 is not equal to K-10, Y11=On and remains in that state.
- When X2 =On and the content of the 32-bit register D0 (D11) is less than 678,493, or M3=On, M50=On.

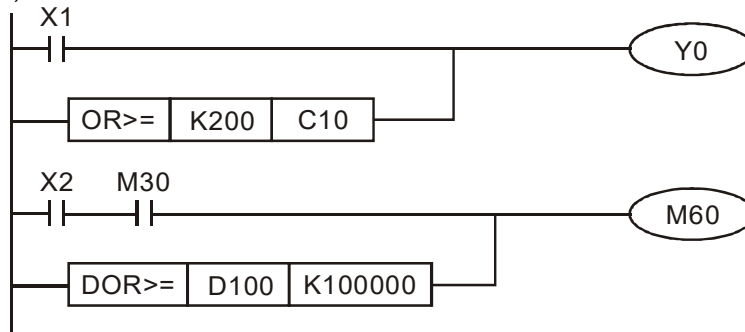



API 275– 280	<b>FLD*</b>	(S1) (S2)	Floating point number contact form compare LD*											
Bit device		Word device				16-bit command								
	X	Y	M	K	H	KnX	KnY	KnM	T	C	D			
S1									*	*	*			
S2									*	*	*			
Notes on operand usage: # : & \   \ ^												32-bit command (9 STEP)		
Please refer to the function specifications table for each device in series for the scope of device usage												FLD* Continuous execution type		
												Flag signal: none		

- Explanation**
- **S<sub>1</sub>**: data source device 1. **S<sub>2</sub>**: data source device 2.
  - This command compares the content of **S<sub>1</sub>** and **S<sub>2</sub>**. Taking "FLD=" as an example, if the result of comparison is "equal," this command will be activated; but it will not be activated when the result is "unequal."
  - The FLD\* command can directly input floating point numerical values (for instance: F1.2) to the **S<sub>1</sub>**, **S<sub>2</sub>** operands, or store floating-point numbers in register D for use in operations.
  - This command can be used while directly connected with the busbar

API No.	32-bit commands	Conditions for activation	Conditions for inactivation
275	FLD=	<b>S<sub>1</sub> = S<sub>2</sub></b>	<b>S<sub>1</sub> ≠ S<sub>2</sub></b>
276	FLD>	<b>S<sub>1</sub> &gt; S<sub>2</sub></b>	<b>S<sub>1</sub> ≤ S<sub>2</sub></b>
277	FLD<	<b>S<sub>1</sub> &lt; S<sub>2</sub></b>	<b>S<sub>1</sub> ≥ S<sub>2</sub></b>
278	FLD<>	<b>S<sub>1</sub> ≠ S<sub>2</sub></b>	<b>S<sub>1</sub> = S<sub>2</sub></b>
279	FLD≤	<b>S<sub>1</sub> ≤ S<sub>2</sub></b>	<b>S<sub>1</sub> &gt; S<sub>2</sub></b>
280	FLD≥	<b>S<sub>1</sub> ≥ S<sub>2</sub></b>	<b>S<sub>1</sub> &lt; S<sub>2</sub></b>

- Example**
- When the floating point number of register D200 (D201) is less than or equal to F1.2, and X1 activated, contact Y21 will be activated and remain in that state.

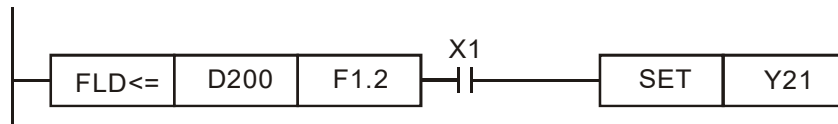

API 281- 286	<b>FAND※</b>		(S1) (S2)		Floating point number contact form compare AND*									
Bit device			Word device									16-bit command		
X	Y	M	K	H	KnX	KnY	KnM	T	C	D	-			
S1								*	*	*	-			
S2								*	*	*	32-bit command (9 STEP)			
Notes on operand usage: # : & 、   、 ^ Please refer to the function specifications table for each device in series for the scope of device usage											FAND※ : Continuous execution type			
Flag signal: none														

Explanation

- **S1**: data source device 1. **S2**: data source device 2.
- This command compares the content of **S1** and **S2**. Taking "FAND=" as an example, if the result of comparison is "equal," this command will be activated; but it will not be activated when the result is "unequal."
- The FAND\* command can directly input floating point numerical values (for instance: F1.2) to the **S1**, **S2** operands, or store floating-point numbers in register D for use in operations.
- This command can be used while directly connected with the busbar

API No.	32-bit commands	Conditions for activation	Conditions for inactivation
281	FAND=	<b>S1 = S2</b>	<b>S1 ≠ S2</b>
282	FAND>	<b>S1 &gt; S2</b>	<b>S1 ≤ S2</b>
283	FAND<	<b>S1 &lt; S2</b>	<b>S1 ≥ S2</b>
284	FAND<>	<b>S1 ≠ S2</b>	<b>S1 = S2</b>
285	FAND<=	<b>S1 ≤ S2</b>	<b>S1 &gt; S2</b>
286	FAND>=	<b>S1 ≥ S2</b>	<b>S1 &lt; S2</b>

Example

- When X1=Off, and the floating point number in register D100 (D101) is not equal to F1.2, Y21=On and remains in that state.

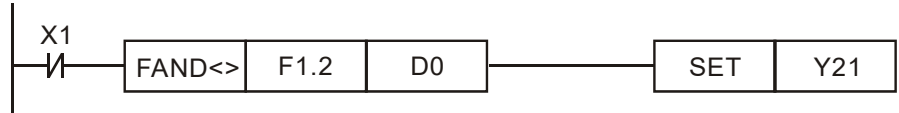

API 287– 292	<b>FOR※</b>		(S1) (S2)		Floating point number contact form compare OR*									
Bit device			Word device									16-bit command		
X	Y	M	K	H	KnX	KnY	KnM	T	C	D	—	—	—	
S1								*	*	*	32-bit command (9 STEP)			
S2								*	*	*	FOR※	Continuous	—	—
Notes on operand usage: # : & \   \ ^											execution type			
Please refer to the function specifications table for each device in series for the scope of device usage											Flag signal: none			

- Explanation**
- **S<sub>1</sub>**: data source device 1. **S<sub>2</sub>**: data source device 2.
  - This command compares the content of **S<sub>1</sub>** and **S<sub>2</sub>**. Taking "FOR=" as an example, if the result of comparison is "equal," this command will be activated; but it will not be activated when the result is "unequal."
  - The FOR\* command can directly input floating point numerical values (for instance: F1.2) to the **S<sub>1</sub>**, **S<sub>2</sub>** operands, or store floating-point numbers in register D for use in operations.
  - This command can be used while directly connected with the busbar

API No.	32-bit commands	Conditions for activation	Conditions for inactivation
287	FOR=	<b>S<sub>1</sub> = S<sub>2</sub></b>	<b>S<sub>1</sub> ≠ S<sub>2</sub></b>
288	FOR>	<b>S<sub>1</sub> &gt; S<sub>2</sub></b>	<b>S<sub>1</sub> ≤ S<sub>2</sub></b>
289	FOR<	<b>S<sub>1</sub> &lt; S<sub>2</sub></b>	<b>S<sub>1</sub> ≥ S<sub>2</sub></b>
290	FOR<>	<b>S<sub>1</sub> ≠ S<sub>2</sub></b>	<b>S<sub>1</sub> = S<sub>2</sub></b>
291	FOR≤	<b>S<sub>1</sub> ≤ S<sub>2</sub></b>	<b>S<sub>1</sub> &gt; S<sub>2</sub></b>
292	FOR≥	<b>S<sub>1</sub> ≥ S<sub>2</sub></b>	<b>S<sub>1</sub> &lt; S<sub>2</sub></b>

- Example**
- When X2 and M30 are both equal to "On," or the floating point number in register D100 (D101) is greater than or equal to F1.234, M60=On.

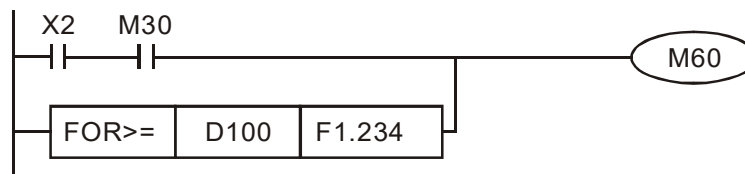

### 16-6-5 Detailed explanation of drive special applications commands

API 139	<b>RPR</b>	<b>P</b>	(S1) (S2)	Read servo parameter
------------	------------	----------	-----------	----------------------

	Bit device			Word device							16-bit command (5 STEP)				
	X	Y	M	K	H	KnX	KnY	KnM	T	C	D	RPR	Continuous execution type	RPRP	Pulse execution type
S1				*	*										
S2															*

Notes on operand usage: none

32-bit command  
Flag signal: none

**Explanation** ■ (S1): Parameter address of data to be read. (S2): Register where data to be read is stored.

API 140	<b>WPR</b>	<b>P</b>	(S1) (S2)	Write servo parameter
------------	------------	----------	-----------	-----------------------

	Bit device			Word device							16-bit command (5 STEP)				
	X	Y	M	K	H	KnX	KnY	KnM	T	C	D	WPR	Continuous execution type	WPRP	Pulse execution type
S1				*	*										
S2				*	*										*

Notes on operand usage: none

32-bit command  
Flag signal: none

**Explanation** ■ (S1): Data to write to specified page. (S2): Parameter address of data to be written.

- Example**
- When the data in the C2000 drive's parameter H01.00 is read and written to D0, data from H01.01 will be read and written to D1.
  - When M0=On, the content of D10 will be written to the C2000 drive parameter 04.00 (first speed of multiple speed levels).
  - When the parameter has been written successfully, M1017=On.
  - The C2000's WPR command does not support writing to the 20XX address, but the RPR command supports reading of 21XX, 22XX.

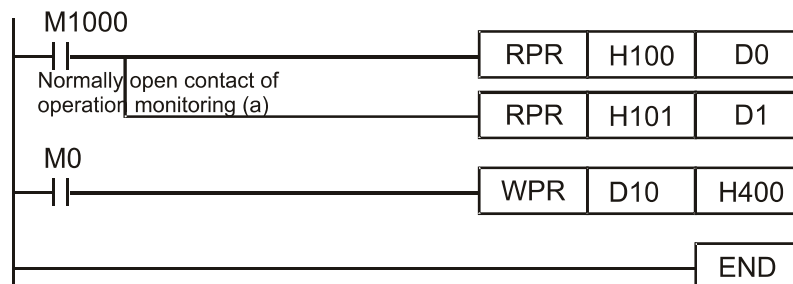

**Recommendation** Take care when using the WPR command. When writing parameters, because most parameters are recorded as they are written, these parameters may only be revised 109 times; a memory write error may occur if parameters are written more than 10<sup>9</sup> times.

Because the following commonly-used parameters have special processing, there are **no** restrictions on the number of times they may be written.

- Pr. 00-10: Control method
- Pr. 00-11: Speed mode selection
- Pr. 00-12: P2P position mode
- Pr. 00-13: Torque mode select
- Pr. 00-27: User-defined value

Pr. 01-12: Acceleration time 1  
Pr. 01-13: Deceleration time 1  
Pr. 01-14: Acceleration time 2  
Pr. 01-15: Deceleration time 2  
Pr. 01-16: Acceleration time 3  
Pr. 01-17: Deceleration time 3  
Pr. 01-18: Acceleration time 4  
Pr. 01-19: Deceleration time 4

Pr. 02-12: Select MI Conversion Time mode:  
Pr. 02-18: Select MO Conversion Time mode:

Pr. 04-50–Pr. 04-69: PLC register parameter 0 - 19

Pr. 08-04: Upper limit of integral  
Pr. 08-05: PID output upper limit

Pr. 10-17: Electronic gear A  
Pr. 10-18: Electronic gear B

Pr. 11-34: Torque command  
Pr. 11-43: P2P highest frequency  
Pr. 11-44: Position control acceleration time  
Pr. 11-45: Position control deceleration time

Calculation of the number of times written is based on whether the written value is modified. For instance, writing the same value 100 times at the same time counts as writing only once.

When writing a PLC program, if unsure of usage of the WPR command, we recommend that you use the WPRP command.

API 141	<b>FPID</b>		<b>P</b>	(S1) (S2) (S3) (S4)	Drive PID control mode										
	Bit device			Word device								16-bit command (9 STEP)			
	X	Y	M	K	H	KnX	KnY	KnM	T	C	D	FPID	Continuous execution type	FPIDP	Pulse execution type
S1				*	*						*				
S2				*	*						*				
S3				*	*						*				
S4				*	*						*				
Notes on operand usage: none												32-bit command			
												— — — —			
												Flag signal: none			

Explanation

- (S1): PID reference target value input terminal select. (S2): PID function proportional gain P. (S3): PID function integral time I. (S4): PID function differential time D.
- The FPID command can directly control the drive's feedback control of PID Pr. 08-00 PID reference target value input terminal selection, Pr. 08-01 proposal gain P, Pr. 08-02 integral time I, and Pr. 08-03 differential time D.

Example

- When M0=On, the set PID reference target value input terminal selection is 0 (no PID function), the PID function proportional gain P is 0, the PID function integral time I is 1 (units: 0.01 sec.), and the PID function differential time D is 1 (units: 0.01 sec.).
- When M1=On, the set PID reference target value input terminal selection is 0 (no PID function), the PID function proportional gain P is 1 (units: 0.01), the PID function integral time I is 0, and the PID function differential time D is 0.
- When M2=On, the set PID reference target value input terminal selection is 1 (target frequency input is controlled from the digital keypad), the PID function proportional gain P is 1 (units: 0.01), the PID function integral time I is 0, and the PID function differential time D is 0.
- D1027: Frequency command after PID operation.

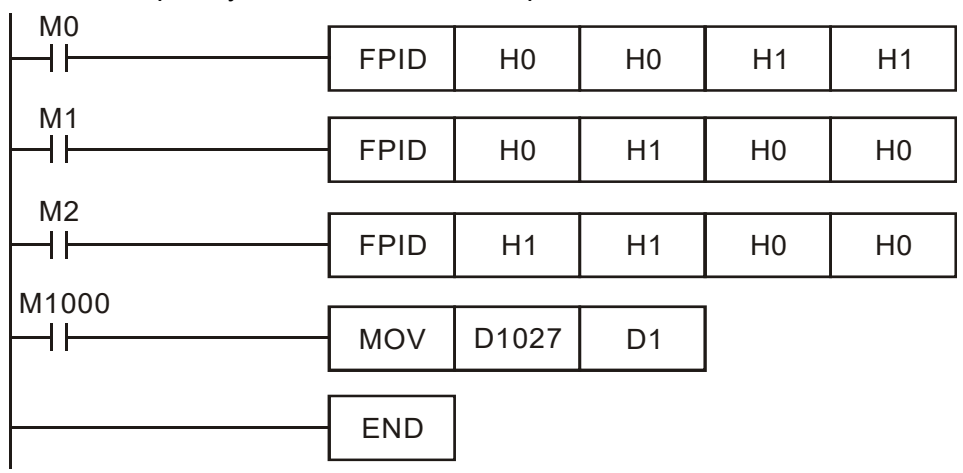

API 142	<b>FREQ</b>		<b>P</b>	(S1) (S2) (S3)	Drive speed control mode										
Bit device			Word device								16-bit command (7 STEP)				
	X	Y	M	K	H	KnX	KnY	KnM	T	C	D	FREQ	Continuous execution type	FREQP	Pulse execution type
S1				*	*										
S2				*	*										
S3				*	*										
Notes on operand usage: none												32-bit command			
												Flag signal: M1015			

- Explanation**
- (S1): Frequency command. (S2): Acceleration time. (S3): Deceleration time
  - S2,S3: In acceleration/deceleration time settings, the number of decimal places is determined by the definitions of Pr. 01-45.

**Example**

When Pr. 01-45=0: units of 0.01 sec.

The setting of 50 for S2 (acceleration time) in the ladder diagram below implies 0.5 sec, and the S3 (deceleration time) setting of 60 implies 0.6 sec

- The FREQ command can control drive frequency commands, and acceleration and deceleration time; it also uses special register control actions, such as:  
 M1025: Control drive RUN(On) / STOP(Off) (RUN requires Servo On (M1040 On) to be effective)  
 M1026: Control drive operating direction FWD(Off) / REV(On)  
 M1040: Control Servo On / Servo Off.  
 M1042: Trigger quick stop (ON) / does not trigger quick stop (Off).  
 M1044: Pause (On) / release pause (Off)  
 M1052: Lock frequency (On) / release lock frequency (Off)

**Example**

- M1025: Drive RUN(On) / STOP(Off), M1026: drive operating direction FWD(Off) / REV(On). M1015: frequency reached.
- When M10=On, sets the drive frequency command K300 (3.00Hz), with an acceleration / deceleration time of 0.  
 When M11=On, sets the drive frequency command K3000 (30.00Hz), with an acceleration time of 50 (0.5 sec.) and deceleration time of 60 (0.6 sec.). (When Pr. 01-45=0)
- When M11=Off, the drive frequency command will now change to 0

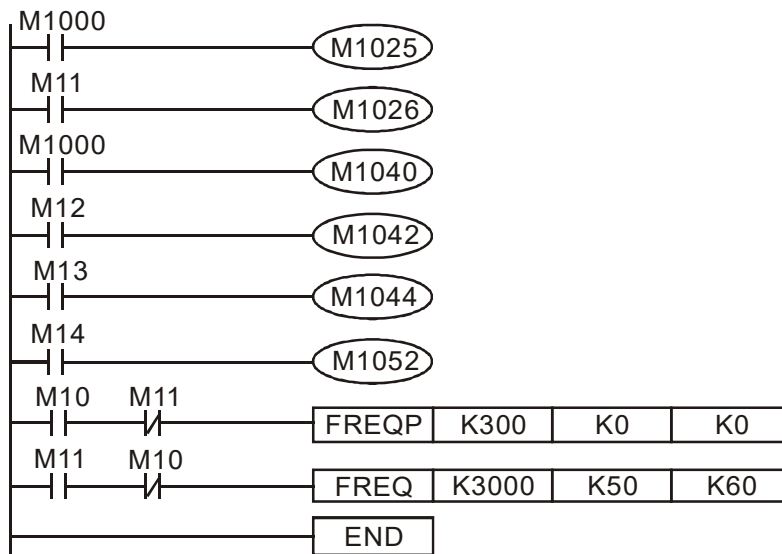

- Pr. 09-33 are defined on the basis of whether reference commands have been cleared before PLC operation.  
 bit0: Prior to PLC scanning procedures, whether the target frequency has been cleared is 0. (This will be written to the FREQ command when the PLC is On)  
 bit1: Prior to PLC scanning procedures, whether the target torque has been cleared is 0. (This will be written to the TORQ command when the PLC is On)  
 bit2: Prior to PLC scanning procedures, whether speed limits in the torque mode have been cleared is 0. (This will be written to the TORQ command when the PLC is On)

Example: When using r to write a program

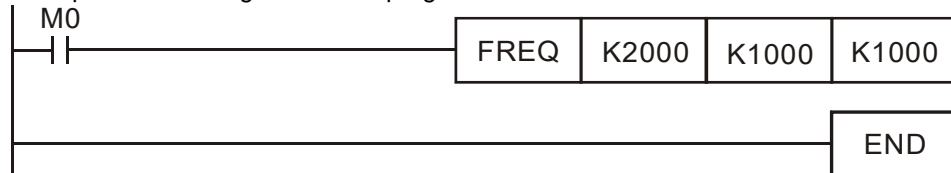

If we force M0 to be 1, the frequency command will be 20.00Hz; but when M0 is set as 0, there will be a different situation.

Case 1: When the Pr.09-33 bit 0 is 0, and M0 is set as 0, the frequency command will remain at 20.00Hz.

Case 2: When the Pr.09-33 bit 0 is 1, and M0 is set as 0, the frequency command will change to 0.00Hz.

The reason for this is that when the Pr.09-33 bit 0 is 1 prior to PLC scanning procedures, the frequency will first revert to 0.

When the Pr.09-33 bit 0 is 0, the frequency will not revert to 0.



API 263	TORQ		P	(S1)	(S2)	Drive torque control mode								
Bit device			Word device								16-bit command (5 STEP)			
X	Y	M	K	H	KnX	KnY	KnM	T	C	D	TORQ	Continuous execution type	TORQ P	Pulse execution type
S1			*	*						*				
S2			*	*						*				
Notes on operand usage: none											32-bit command			
											Flag signal: M1063			

Explanation

- (S1): Torque command (numbered, no more than one digit). (S2): Speed limit.
- The TORQ command can control the drive torque command and speed limits; it also uses special register control actions, such as:  
M1040: Controls Servo On/Servo Off. When Servo is ON, if a TORQ command is executed, the torque will output the torque defined by the TORQ command, and the frequency restrictions will similarly be controlled by the TORQ command.

Example

- M1040: Control Servo On/Servo Off. M1063: set torque attained. D1060 is the mode controls. D1053 is the actual torque.
- When M0=Off, set the drive torque command K+500 (+50.0%), rotational speed restrictions is 3000 (30Hz).
- When M0=On, sets the drive torque command K-300 (-30.0%), rotational speed restrictions is 3000 (30Hz).
- When M10=On, drive began output torque command.
- When set torque is attained, M1063 will go On; this flag usually jumps continuously, however.

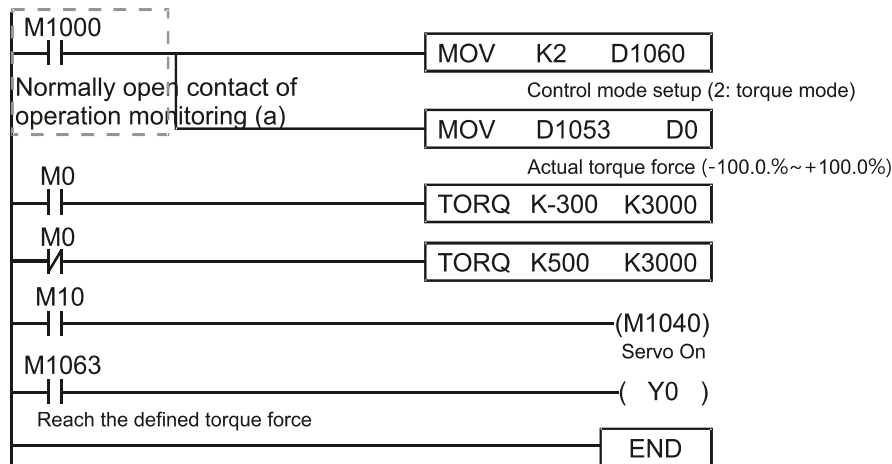

- Pr. 09-33 are defined on the basis of whether reference commands have been cleared before PLC operation.  
bit0: Prior to PLC scanning procedures, whether the target frequency has been cleared is 0. (This will be written to the FREQ command when the PLC is On)  
bit1: Prior to PLC scanning procedures, whether the target torque has been cleared is 0. (This will be written to the TORQ command when the PLC is On)  
bit2: Prior to PLC scanning procedures, whether speed limits in the torque mode have been cleared is 0. (This will be written to the TORQ command when the PLC is On)

Example:

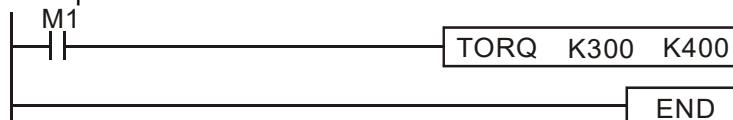

If we now force M1 to be 1, the torque command will be K+300 (+30%), and the speed limit will be 400 (40Hz). But when M1 is set as 0, there will be a different situation.  
Case 1: When bit 1 and bit 2 of Pr. 09-33 are both set as 0, and M1 is set as 0, the torque command will remain at +30%, and the speed limit will be set as 40Hz.  
Case 2: When bit 2 of Pr. 09-33 are both 1, and M1 is set as 0, the torque command will revert 0%, and the speed limit will be set as 0Hz.

API 262	<b>DPOS</b>		<b>P</b>	<b>(S1)</b>								Drive point-to-point control		
Bit device			Word device								16-bit command			
X	Y	M	K	H	KnX	KnY	KnM	T	C	D	-	-	-	-
			*	*						*	32-bit command (5 STEP)			
Notes on operand usage: none											DPOS	Continuous	DPOSP	Pulse
											execution type		execution type	
											Flag signal: M1064, M1070			

Explanation

- **(S1)**: Target (must have a number).
- The DPOS command can control the drive's position commands, and employs special register control actions, such as:  
 M1040: Control Servo On/Servo Off. M1055 search for origin. M1048 move to new position. If the control mode is position mode (D1060 = 1), and the converter is in the Servo ON state (M1040 = 1), if the DPOS command is executed, the drive will move to a new position in conjunction with activation of M1048 once (OFF to ON).

Example

- M1040: Control Servo On/Servo Off. M1064: set position attained. D1060 is the mode control. D1051(L) and D1052(H) are the actual position points.
- When X0=On, M1040 will be On (Servo On).
- When X1=On, sets DPOS position as +300000, and M1048 will change to On (move to new position) after a delay of 1 sec. Check whether the value of D1051 has changed at this time; after the set position point has been reached, M1064 will go On, and Y0 will output On.

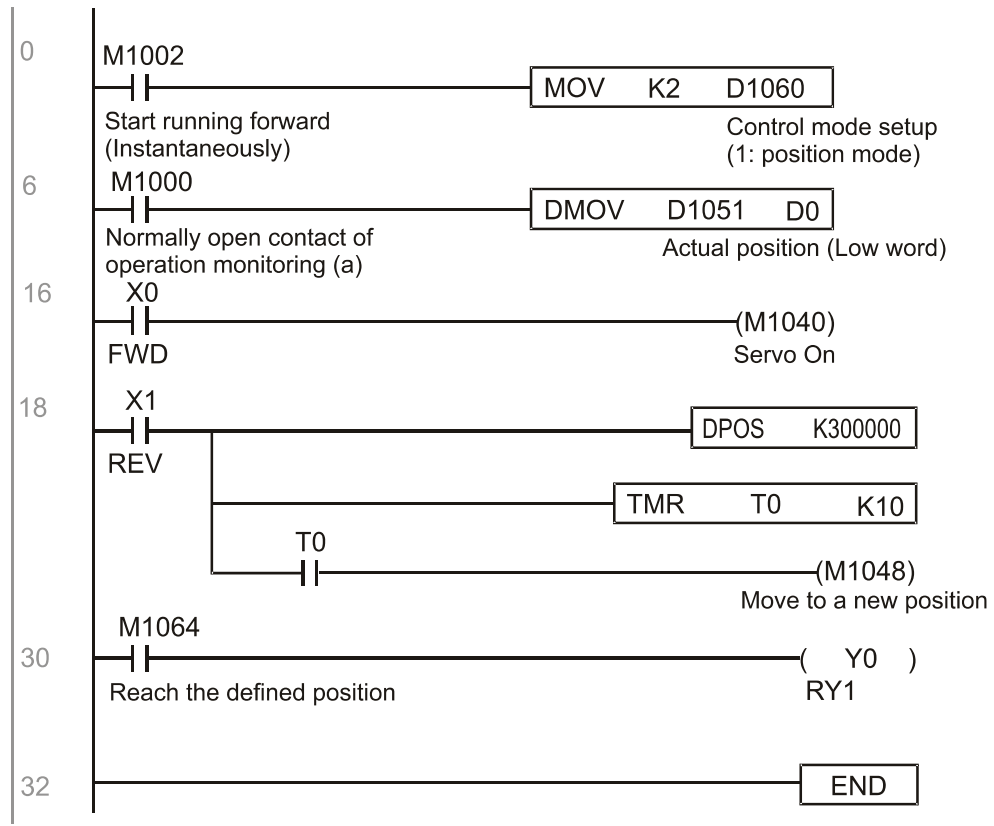

API 261	<b>CANRX</b>		P		(S1) (S2) (S3) (D)	Read CANopen slave station data								
Bit device			Word device								16-bit command (9 STEP)			
X	Y	M	K	H	KnX	KnY	KnM	T	C	D	CANRX	Continuous execution type	CANRX	Pulse execution type
S1			*	*										
S2			*	*										
S3			*	*							32-bit command			
D								*	*	*				
Notes on operand usage: none											Flag signal			

Explanation ■ (S1): Slave station number. (S2): Main index.. (S3): Subindex+bit length. (D): Preset address.

- The CANRX command can read the index of the corresponding slave station. When it is executed, it will send the SDO message format to the slave station. M1066 and M1067 will both be 0 at that time, and M1066 will be set as 1 after reading. If the slave station gives the correct response, it will write the value to the preset register, and set M1067 as 1. If the slave station has a response error, M1067 will be set as 0, and an error message will be recorded to D1076 to D1079.

Example M1002: When the PLC runs, the command will be triggered once and will set K4M400 = K1

Afterwards, each time M1066 is 1, it will switch to a different message.

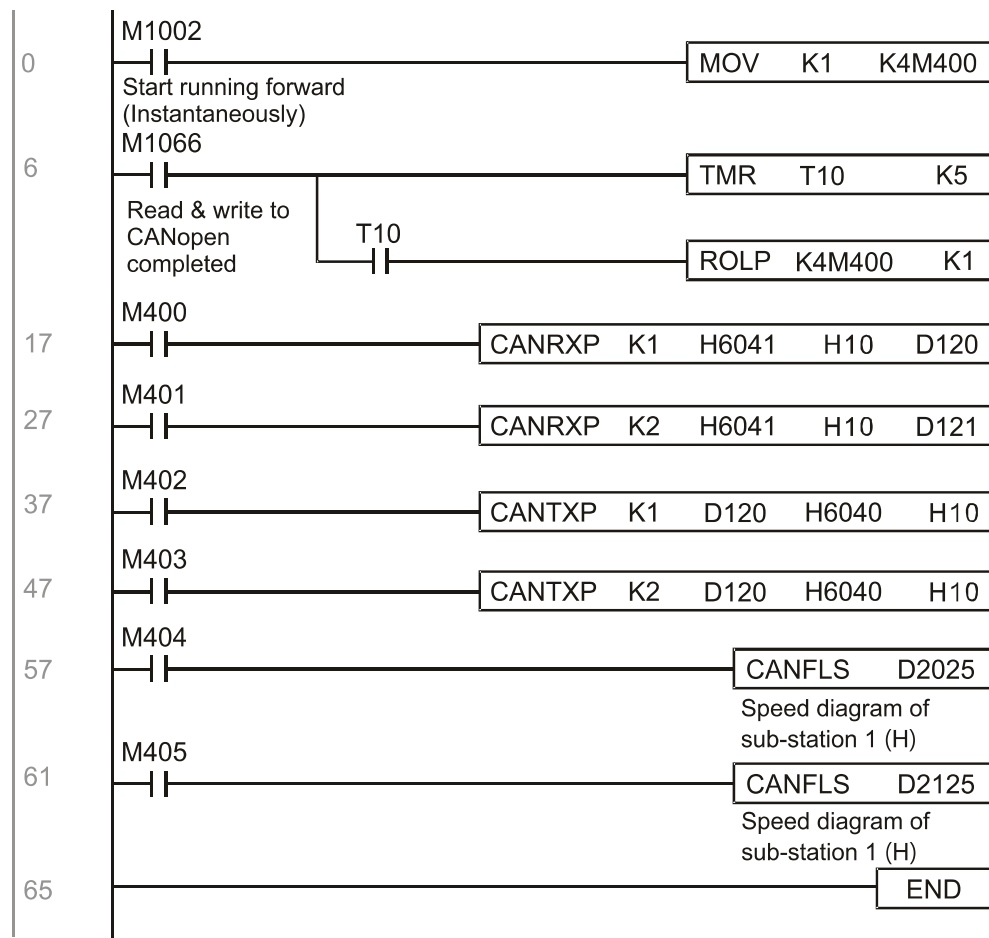

API 264	<b>CANTX</b>		<b>P</b>	(S1) (S2) (S3) (S4)	Write CANopen slave station data										
	Bit device			Word device								16-bit command (9 STEP)			
	X	Y	M	K	H	KnX	KnY	KnM	T	C	D	CANTX	Continuous execution type	CANTXP	Pulse execution type
S1				*	*										
S2				*	*				*	*	*				
S3				*	*										
S4				*	*										
Notes on operand usage: none												32-bit command			
												Flag signal			

Explanation

- (S1): Slave station number. (S2): Address to be written. (S3): Main index. (S4): Subindex+bit length.
- The CANTX command can write a value to the index of the corresponding slave station. When it is executed, it will send the SDO message format to the slave station. M1066 and M1067 will both be 0 at that time, and M1066 will be set as 1 after reading. If the slave station gives the correct response, it will write the value to the preset register, and set M1067 as 1. If the slave station has a response error, M1067 will be set as 0, and an error message will be recorded to D1076 to D1079.

API 265	<b>CANFLS</b>		<b>P</b>	<b>(D)</b>							Refresh special D corresponding to CANopen			
Bit device			Word device								16-bit command (3 STEP)			
X	Y	M	K	H	KnX	KnY	KnM	T	C	D	CANFLS	Continuous execution type	CANFLSP	Pulse execution type
D			*	*										
Notes on operand usage: none											32-bit command			
											Flag signal			

- Explanation**
- **(D)**: Special D to be refreshed.
  - The CANFLS command can refresh special D commands. When is a read only attribute, executing this command will send a message equivalent to that of CANRX to the slave station, and the number of the slave station will be transmitted back and refreshed to this special D. When there is a read/write attribute, executing this command will send a message equivalent to that of CANTX to the slave station, and the value of this special D will be written to the corresponding slave station.
  - When M1066 and M1067 are both 0, and M1066 is set as 1 after reading, if the slave station gives a correct response, the value will be written to the designated register, and M1067 will be set as 1. If the slave station's response contains an error, then M1067 will be set as 0, and an error message will be recorded to D1076–D1079.

API 320	<b>D</b>	<b>ICOMR</b>		<b>P</b>	<b>(S1) (S2) (S3) (D)</b>							Internal communications read		
Bit device			Word device								16-bit command (9 STEP)			
X	Y	M	K	H	KnX	KnY	KnM	T	C	D	ICOMR	Continuous execution type	ICOMRP	Pulse execution type
S1			*	*						*				
S2			*	*						*				
S3			*	*						*				
D			*	*						*				
Notes on operand usage: none											32-bit command (17 STEP)			
											Flag signal: M1077 M1078 M1079			

- Explanation**
- **(S1)**: Selection of slave device. **(S2)**: Device selection (0: converter, 1: internal PLC). **(S3)**: Read address. **(D)**: Saving target.
  - The ICOMR command can obtain the slave station's converter and the internal PLC's register value.

API 321	D	ICOMW	P	(S1) (S2) (S3) (D)	Internal communications write										
Bit device		Word device										16-bit command (9 STEP)			
X	Y	M	K	H	KnX	KnY	KnM	T	C	D	ICOMW	Continuous execution type	ICOMW	Pulse execution type	
S1			*	*						*					
S2			*	*						*					
S3			*	*						*					
D			*	*						*					
Notes on operand usage: none											32-bit command (17 STEP)				
											DICOM	Continuous execution type	DICOM	Pulse execution type	
											W		WP		
											Flag signal: M1077 M1078 M1079				

Explanation

(S1): Selection of slave device. (S2): Device selection (0: converter, 1: internal PLC). (S3): Read address. (D): Saving target.

■ The ICOMW command write a value to the slave station's converter and the internal PLC's register.

Example

Please refer to the following example:

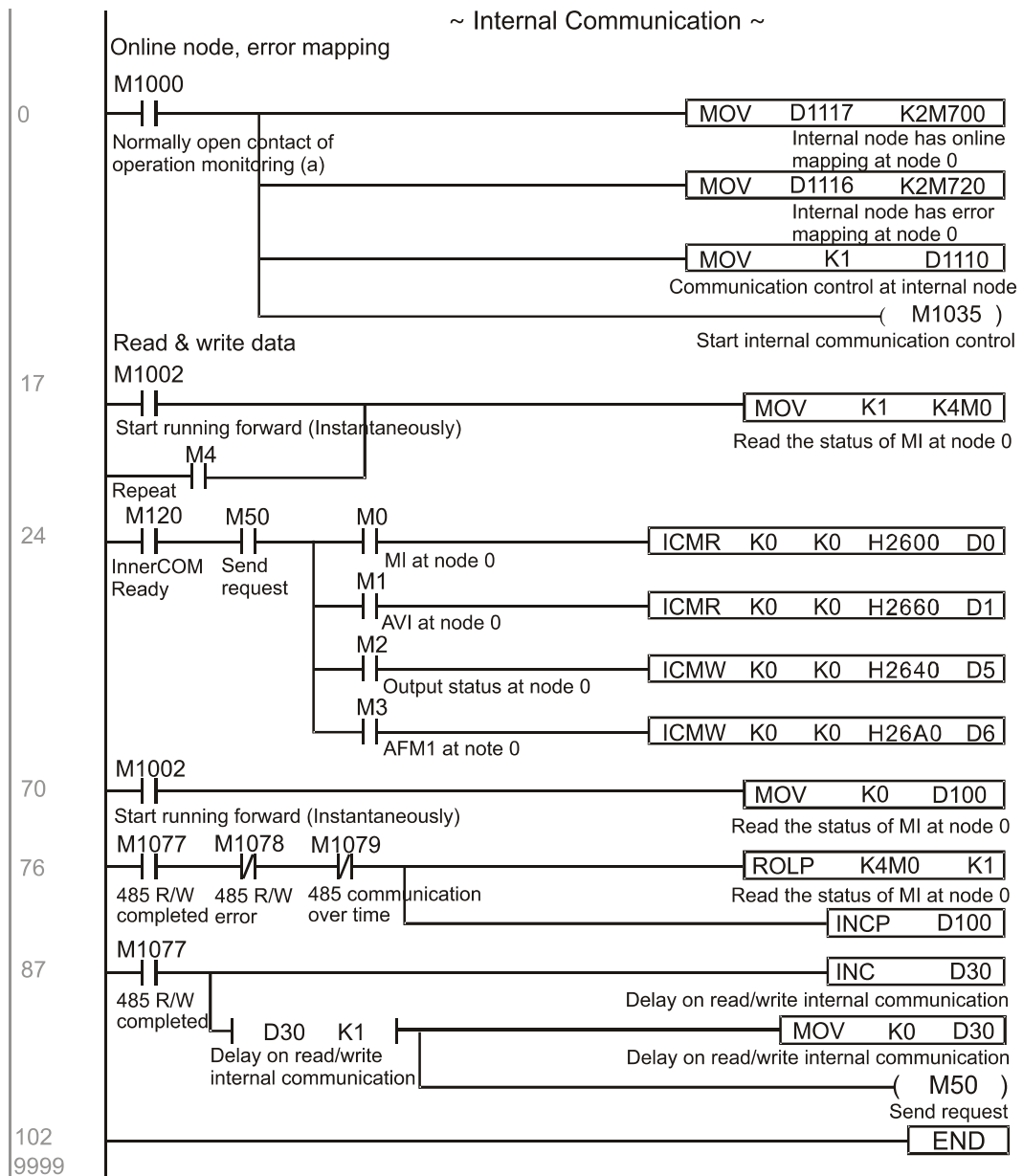

API 323	WPR		P	(S1)	(S2)	Drive parameters write-in								
Bit device			Word device							16-bit command (5 STEP)				
X	Y	M	K	H	KnX	KnY	KnM	T	C	D	WORA	Continuous execution type	WORAP	Pulse execution type
S1			*	*						*				
S2			*	*						*				
Notes on operand usage: none											32-bit command			
											-			
											-			
											-			
											-			
											Flag signal: none			

**Explanation** (S1): Data that is going to write in (S2): Parameter address of the write-in data

- Example**
- Read the data of C2000 drive's parameter H01.00 and write into D0, read data of H01.01 and write into D1.
  - When M0 is ON, write the content of D10 into C2000 drive's Pr.04-00 (1<sup>st</sup> step speed frequency).
  - When parameter writes-in successfully, M1017 is ON.
  - The WPR command does not support the write-in of 20XX address, but the RPR command supports the read-out of 21XX and 22XX.

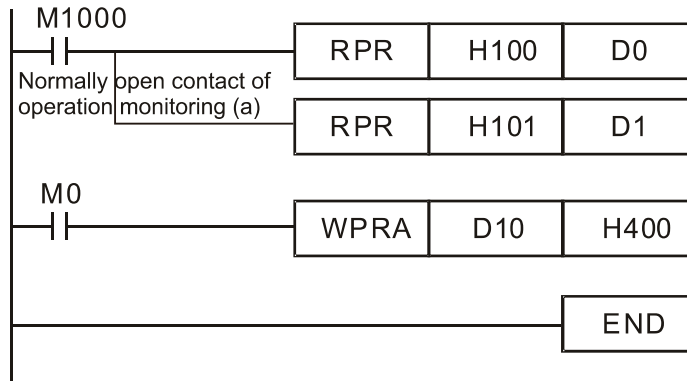

**Recommendation** ■ When WPR executes, the data is only written into the RAM area, and will get back to previous record when the power is off.

## 16-7 Error display and handling

Code	ID	Descript	Recommended handling approach
PLrA	47	RTC time check	Turn power on and off when resetting the keypad time
PLrt	49	Incorrect RTC time	Turn power on and off after making sure that the keypad is securely connected
PLod	50	Data writing memory error	Check whether the program has an error and download the program again
PLSv	51	Data write memory error during program execution	Restart power and download the program again
PLdA	52	Program transmission error	Try uploading again; if the error persists, sent to the manufacturer for service
PLFn	53	Command error while downloading program	Check whether the program has an error and download the program again
PLor	54	Program exceeds memory capacity or no program	Restart power and download the program again
PLFF	55	Command error during program execution	Check whether the program has an error and download the program again
PLSn	56	Check code error	Check whether the program has an error and download the program again
PLEd	57	Program has no END stop command	Check whether the program has an error and download the program again
PLCr	58	MC command has been used continuously more than nine times	Check whether the program has an error and download the program again
PLdF	59	Download program error	Check whether the program has an error and download again
PLSF	60	PLC scan time excessively long	Check whether the program code has a writing error and download again



## 16- 8 CANopen Master control applications

Control of a simple multi-axis application is required in certain situations. If the device supports the CANopen protocol, a C2000 can serve as the master in implementing simple control (position, speed, homing, and torque control). The setting method comprises the following seven steps:

### Step 1: Activating CANopen Master functions

1. Pr. 09-45=1 (initiates Master functions); restart power after completing setting, the status bar on the KPC-CC01 digital keypad will display "CAN Master".
2. Pr. 00-02=6 reset PLC (please note that this action will reset the program and PLC registers to the default values)
3. Turn power off and on again.
4. Use the KPC-CC01 digital keypad to set the PLC control mode as "**PLC Stop**" (if a newly-introduced drive is used, the blank internal PLC program will cause a PLFF warning code to be issued).

### Step 2: Master memory settings

1. After connecting the 485 communications cable, use WPL Soft to set the PLC **status** as Stop (if the PLC mode has been switched to the "**PLC Stop**" mode, the PLC **status** should already be Stop)
2. Set the address and corresponding station number of the slave station to be controlled. For instance, if it is wished to control two slave stations (a maximum of 8 stations can be controlled simultaneously), and the station numbers are 21 and 22, it is only necessary to set D2000 and D2100 as 20 and 21, and then set D2200, D2300, D2400, D2500, D2600, and D2700 as 0. The setting method involves use of the PLC's WPL editing software WPL as follows:

- Open WPL and implement **communications > register edit (T C D)** function

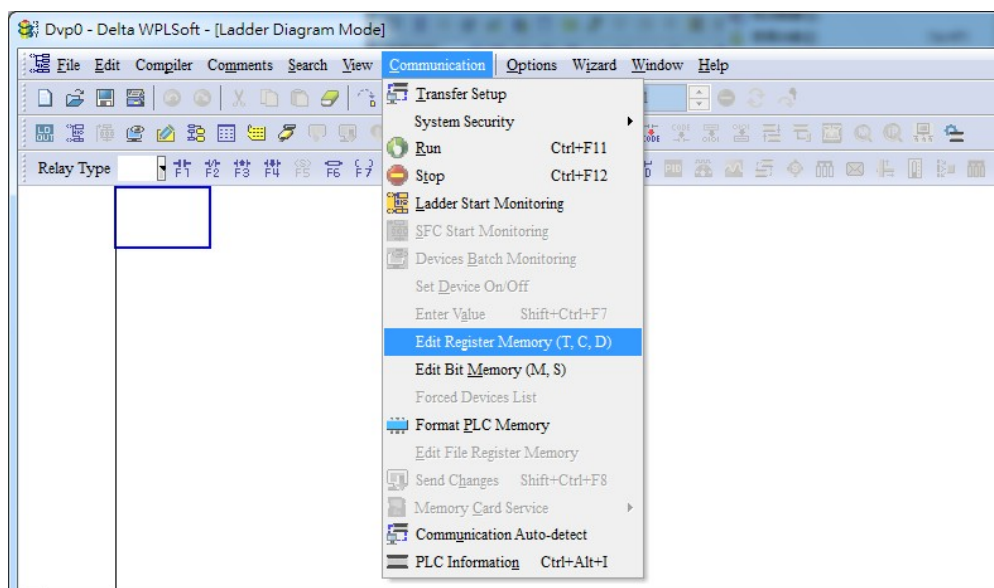

- After leaving the PLC register window, the register setting screen will appear, as shown below:

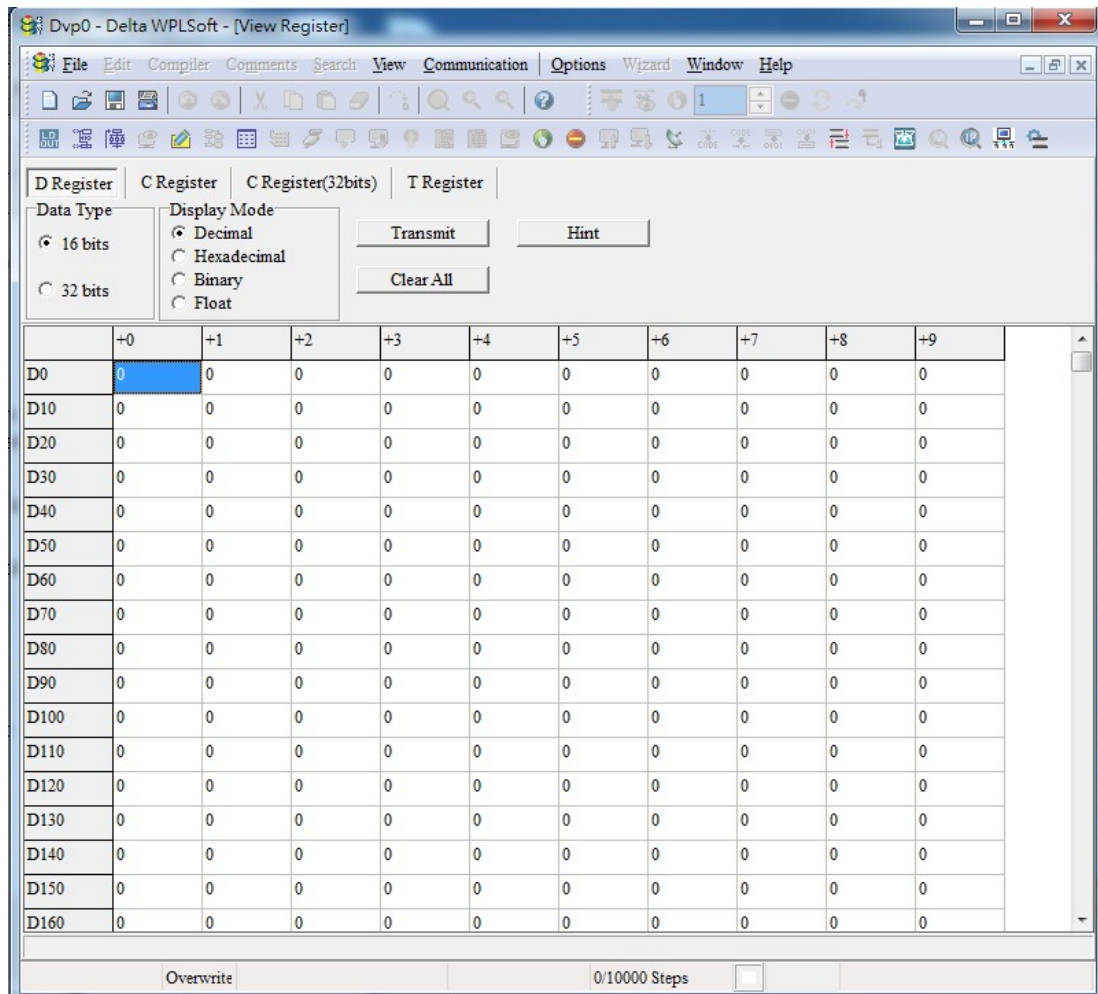

If there is a new PLC program and no settings have been made yet, you can read default data from the converter, and merely edit it to suit the current application.

If settings have already been made, however, the special D in the CANopen area will display the saved status (the CANopen D area is located at D1090 to D1099 and D2000 to D2799). Assuming it is a new program, we will first read the default data from the converter; check the communications format if there is no communications link (the default PLC station number is 2, 9600, 7N2, ASCII). Perform the following steps:

1. Switch the PLC to Stop status
2. Press the transmit button
3. Click on read memory after exiting the window
4. Ignore D0–D399
5. Click on the confirm button.

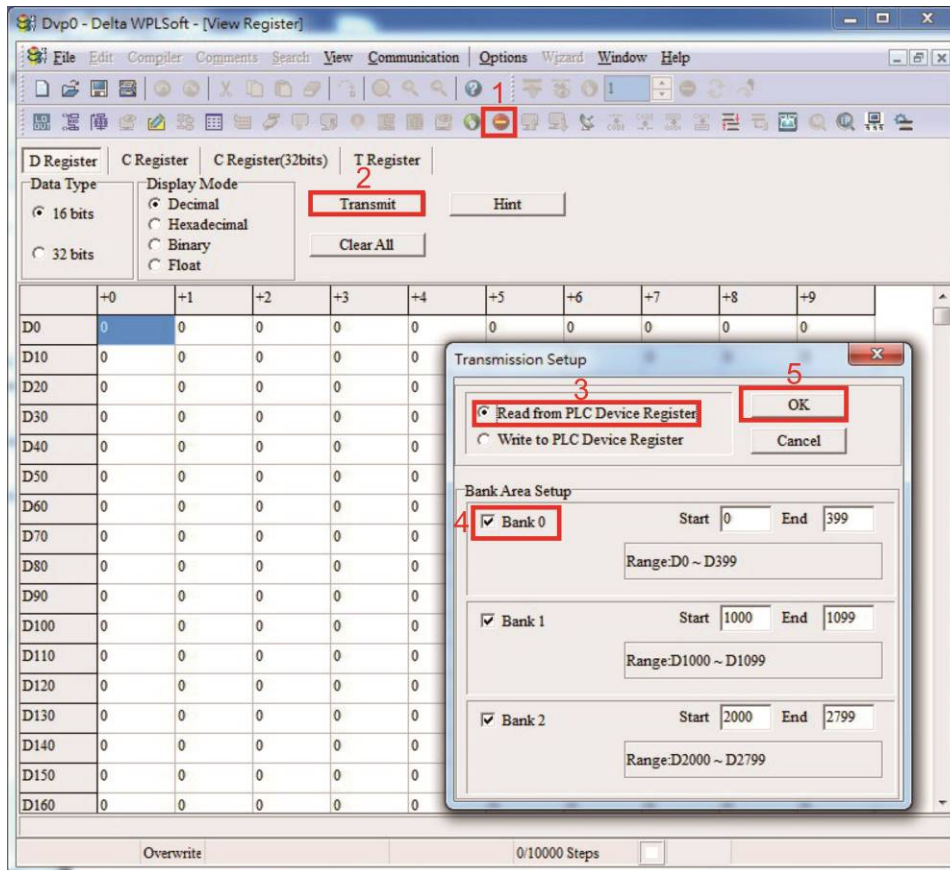

After reading the data, it is necessary to perform some special D settings. Before proceeding, we will first introduce the special D implications and setting range.

The CANopen Master's special D range is currently D1070 to D1099 and D2000 to D2799; this range is divided into 3 blocks:

- The first block is used to display CANopen's current status, and has a range of D1070–D1089
- The second block is used for CANopen's basic settings, and has a range of D1090–D1099
- The third block is the slave station mapping and control area, and has a range of D2000–D2799.

These areas are therefore introduced as follows:

The first contains the current CANopen status display:

When the master initializes a slave station, we can find out from D1070 whether configuration of the slave device has been completed; we can find out whether an error occurred in the configuration process from D1071 and whether the configuration is inappropriate from D1074.

After entering normal control, we can find out whether the slave device is offline from D1073. In addition, we can check the slave device's read/write information using the CANRX, CANTX, and CANFLS commands; error information can be obtained from D1076 to D1079 if there has been a read/write failure.

Special D	Description of Function	R/W
D1070	Channel opened by CANopen initialization (bit0=Machine code0 .....)	R
D1071	Error channel occurring in CANopen initialization process (bit0=Machine code0 .....)	R
D1072	Reserved	-

Special D	Description of Function	R/W
D1073	CANopen break channel (bit0=Machine code0 .....	R
D1074	Error code of master error 0: No error 1: Slave station setting error 2: Synchronizing cycle setting error (too small)	R
D1075	Reserved	-
D1076	SDO error message (main index value)	R
D1077	SDO error message (secondary index value)	R
D1078	SDO error message (error code L)	R
D1079	SDO error message (error code H)	R

The second area is for basic CANopen settings: (the PLC must have **stopped** when this area is used to make settings)

We must set the information exchange time for the master and slave station,

Special D	Description of Function	Default:	R/W
D1090	Synchronizing cycle setting	4	RW

Use D1090 to perform settings; setting time relationships include:

$$\text{Sync time} \geq \frac{1M}{\text{Rate}} * \frac{N}{4}$$

**N: TXPDO + RXPDO**

For instance, when communications speed is 500K, TXPDO + RXPDO have 8 sets, and synchronizing time will require more than 4 ms

We must also define how many slave stations will be opened. D1091 is the channel for defining station opening, and D2000+100\*n is the station number defining this channel. See the detailed explanation below.

Slave station number n=0-7

Special D	Description of Function	R/W
D1091	Sets slave station On or Off (bit 0-bit 7 correspond to slave stations number 0-7)	RW
D2000+100*n	Slave station number	RW

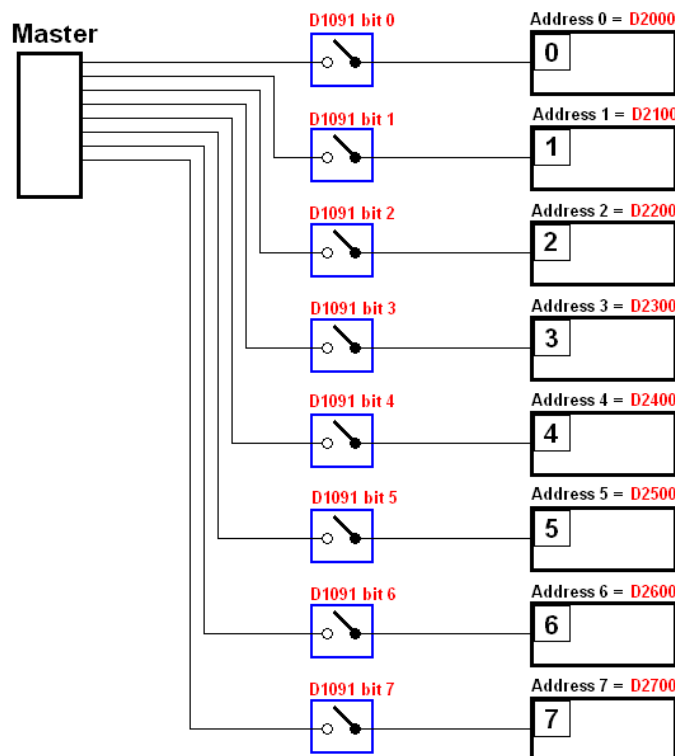

If slave devices have a slow start-up, the master can delay for a short time before performing slave station configuration; this time delay can be set via D1092.

Special D	Description of Function	Default	R/W
D1092	Delay before start of initialization	0	RW

With regard to slave device initialization, a delay time can be set to judge whether failure has occurred. If the communications speed is relatively slow, the delay time can be adjusted to judge whether initialization has been completed, which will ensure that there is time to perform slave device initialization.

Special D	Description of Function	Default	R/W
D1099	Initialization completion delay time Setting range: 1 to 60000 sec.	15 sec.	RW

After communication is successful, the system must detect whether there is a break in communications with the slave station. D1093 is used to set detection time, and D1094 sets the number of consecutive errors that will trigger a break error.

Special D	Description of Function	Default	R/W
D1093	Break time detection	1000ms	RW
D1094	Break number detection	3	RW

The packet type transmitted by PDO is set before establishing normal communications and generally does not require adjustment.

Special D	Description of Function	Default	R/W
D1097	Corresponding real-time transmission type (PDO) Setting range: 1–240	1	RW
D1098	Corresponding real-time receiving type (PDO) Setting range: 1–240	1	RW

The third block is the slave station mapping and control area.

CANopen provides a PDO method to perform mapping of the master and slave station memory, and enables the master to directly access read/write data in a certain memory area. The master will automatically perform data exchange with the corresponding slave device, and the read/write values can be seen directly from the special D area after real-time exchange (M1034 = 1 time) has been established. The C2000 currently supports real-time mapping of four PDOs, and there are two types of PDO RXPDO (reads slave device information) and TXPDO (writes to slave device). In addition, in order to facilitate control, the C2000 cannot perform mapping of commonly-used registers; the following is an overview of the current PDO mapping situation:

TXPDO							
PDO4 (Torque)		PDO3 (Position)		PDO2 (Remote I/O)		PDO1 (Speed)	
Description	Special D	Description	Special D	Description	Special D	Description	Special D
Controller word	D2008+100*n	Controller word	D2008+100*n	Slave device DO	D2027+100*n	Controller word	D2008+100*n
Target torque	D2017+100*n	Target position	D2020+100*n D2021+100*n	Slave device AO1	D2031+100*n	Target speed	D2012+100*n
Control method	D2010+100*n	Control method	D2010+100*n	Slave device AO2	D2032+100*n		
				Slave device AO3	D2033+100*n		

RXPDO							
PDO4 (Torque)		PDO3 (Position)		PDO2 (Remote I/O)		PDO1 (Speed)	
Description	Special D	Description	Special D	Description	Special D	Description	Special D
Mode word	D2009+100*n	Mode word	D2009+100*n	Slave device DI	D2026+100*n	Mode word	D2009+100*n
Actual torque	D2018+100*n	Actual position	D2022+100*n D2023+100*n	Slave device AI1	D2028+100*n	Actual frequency	D2013+100*n
Actual mode	D2011+100*n	Actual mode	D2011+100*n	Slave device AI2	D2029+100*n		
				Slave device AI3	D2030+100*n		

Because usage requires only simple to open the corresponding PDO, where TXPDO employs D2034+100\*n settings and RXPDO employs D2067+100\*n settings.

These two special D areas are defined as follows:

	PDO4		PDO3		PDO2		PDO1	
Default definition	Torque		Position		Remote I/O		Speed	
bit	15	14–12	11	10–8	7	6–4	3	2–0
Definition	En	Length	En	Length	En	Length	En	Length

En: indicates whether PDO is used

Length: indicates mapping of several variables

In a simple example, if we want to control a C2000 slave device and make it to operate in speed mode, we only have to make the following settings:

**D2034+100\*n =000Ah**

Length:	TX PDO							
	PDO4		PDO3		PDO2		PDO1	
	Description	Special D	Description	Special D	Description	Special D	Description	Special D
1	Controller Word	D2008+100*n	Controller Word	D2008+100*n	Slave device DO	D2027+100*n	Controller Word	D2008+100*n
2	Target torque	D2017+100*n	Target	D2020+100*n D2021+100*n	Slave device AO1	D2031+100*n	Target speed	D2012+100*n
3	Control method	D2010+100*n	Control method	D2010+100*n	Slave device AO2	D2032+100*n		
4					Slave device AO3	D2033+100*n		

	PDO4		PDO3		PDO2		PDO1	
Definition	Torque		Position		Remote I/O		Speed	
bit	15	14–12	11	10–8	7	6–4	3	2–0
Definition	0	0	0	0	0	0	1	2

**D2067+100\*n =000Ah**

Length:	TX PDO							
	PDO4		PDO3		PDO2		PDO1	
	Description	Special D	Description	Special D	Description	Special D	Description	Special D
1	Controller Word	D2009+100*n	Controller Word	D2009+100*n	Slave device DI	D2026+100*n	Controller Word	D2009+100*n
2	Actual torque	D2018+100*n	Actual position	D2022+100*n D2023+100*n	Slave device AI1	D2028+100*n	Actual frequency	D2013+100*n
3	Actual mode	D2011+100*n	Actual mode	D2011+100*n	Slave device AI2	D2029+100*n		
4					Slave device AI3	D2030+100*n		

	PDO4		PDO3		PDO2		PDO1	
Definition	Torque		Position		Remote I/O		Speed	
bit	15	14–12	11	10–8	7	6–4	3	2–0
Definition	0	0	0	0	0	0	1	2

Switch the PLC to Run after completing settings. Now wait for successful initialization of CANopen (M1059 = 1 and M1061 = 0), and then initiate CANopen memory mapping (M1034 = 1). The control word and frequency command will now automatically refresh to the corresponding slave device (D2008+n\*100 and D2012+n\*100), and the slave device's status word and currently



frequency will also be automatically sent back to the master station (D2009+n\*100 and D2013+n\*100). This also illustrates how the master can handle these tasks through read/write operations in the special D area.

Furthermore, it should be noted that the remote I/O of PDO2 can obtain the slave device's current DI and AI status, and can also control the slave device's DO and AO status. Nevertheless, after introducing a fully automatic mapping special D, the C2000 CANopen master also provides additional information refreshes. For instance, while in speed mode, acceleration/deceleration settings may have been refreshed. The special D therefore also stores some seldom-used real-time information, and these commands can be refreshed using the CANFLS command. The following is the C2000's current CANopen master data conversion area, which has a range of D2001+100\*n–D2033+100\*n, as shown below:

1. The range of n is 0–7
2. ●Indicates PDOTX, ▲Indicates PDORX; unmarked special D can be refreshed using the CANFLS command

Special D	Description of Function	Default	PDO Default				R/W
			1	2	3	4	
D2000+100*n	Station number n of slave station Setting range: 0–127 0: No CANopen function	0					RW
D2002+100*n	Manufacturer code of slave station number n (L)	0					R
D2003+100*n	Manufacturer code of slave station number n (H)	0					R
D2004+100*n	Manufacturer's product code of slave station number n (L)	0					R
D2005+100*n	Manufacturer's product code of slave station number n (H)	0					R

Basic definitions

Special D	Description of Function	Default	PDO Default				R/W
			1	2	3	4	
D2006+100*n	Communications break handling method of slave station number n	0					RW
D2007+100*n	Error code of slave station number n error	0					R
D2008+100*n	Control word of slave station number n	0	●		●	●	RW
D2009+100*n	Status word of slave station number n	0	▲		▲	▲	R
D2010+100*n	Control mode of slave station number n	2					RW
D2011+100*n	Actual mode of slave station number n	2					R

## Velocity Control

Special D	Description of Function	Default	PDO Default				R/W
			1	2	3	4	
D2001+100*n	Torque restriction on slave station number n	0					RW
D2012+100*n	Target speed of slave station number n (rpm)	0	•				RW
D2013+100*n	Actual speed of slave station number n (rpm)	0	▲				R
D2014+100*n	Error speed of slave station number n (rpm)	0					R
D2015+100*n	Acceleration time of slave station number n (ms)	1000					RW
D2016+100*n	Deceleration time of slave station number n (ms)	1000					RW

## Torque control

Special D	Description of Function	Default	PDO Default				R/W
			1	2	3	4	
D2017+100*n	Target torque of slave station number n (-100.0% – +100.0%)	0				•	RW
D2018+100*n	Actual torque of slave station number n (XX.X%)	0				▲	R
D2019+100*n	Actual current of slave station number n (XX.XA)	0					R

## Position control

Special D	Description of Function	Default:	PDO Default:				R/W
			1	2	3	4	
D2020+100*n	Target of slave station number n (L)	0					RW
D2021+100*n	Target of slave station number n (H)	0			•		RW
D2022+100*n	Actual position of slave station number n (L)	0			▲		R
D2023+100*n	Actual position of slave station number n (H)	0					R
D2024+100*n	Speed chart of slave station number n (L)	10000					RW
D2025+100*n	Speed chart of slave station number n (H)	0					RW

## Remote I/O

Special D	Description of Function	Default:	PDO Default:				R/W
			1	2	3	4	
D2026+100*n	MI status of slave station number n	0		▲			R
D2027+100*n	MO setting of slave station number n	0		•			RW
D2028+100*n	AI1 status of slave station number n	0		▲			R
D2029+100*n	AI2 status of slave station number n	0		▲			R
D2030+100*n	AI3 status of slave station number n	0		▲			R
D2031+100*n	AO1 setting of slave station number n	0		•			RW
D2032+100*n	AO2 setting of slave station number n	0		•			RW
D2033+100*n	AO3 setting of slave station number n	0		•			RW



After gaining an understanding of special D definitions, we return to setting steps. After entering the values corresponding to D1090 to D1099, D2000+100\*n, D2034+100\*n and D2067+100\*n, we can begin to perform downloading, which is performed in accordance with the following steps:

1. D2000 and D2100 are set as 20 and 21, and D2200, D2300, D2400, D2500, D2600, and D2700 are set as 0; if a setting of 0 causes problems, D1091 can be set as 3, and slave stations 2 to 7 can be closed.
2. Switch PLC to Stop status.
3. Press the transmit button.
4. Click on write memory after exiting the window.
5. Ignore D0–D399.
6. Change the second range to D1090–D1099.
7. Click on Confirm.

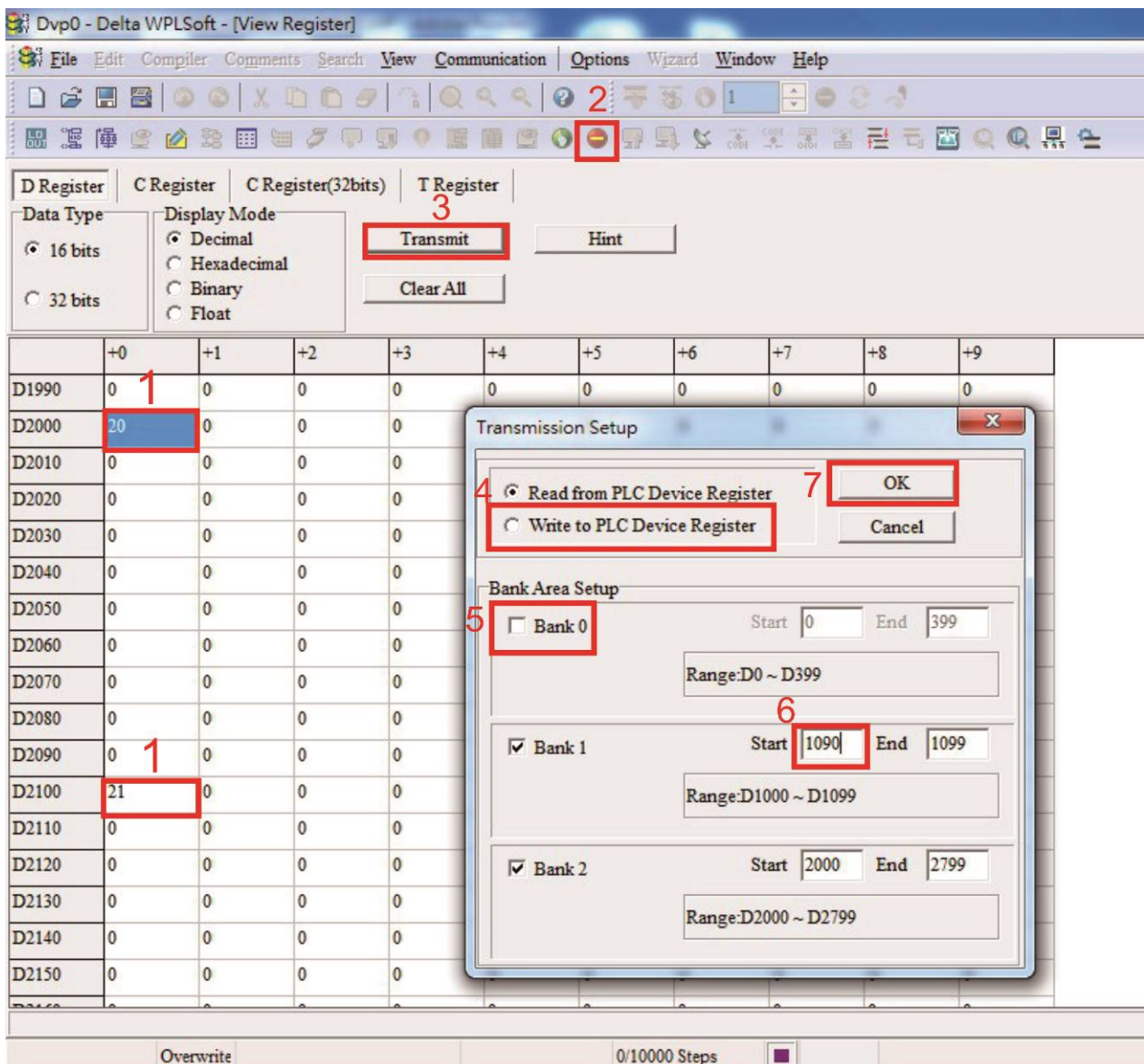

- Another method can be used to set D1091: Determine which of slave stations 0 to 7 will not be needed, and set the corresponding bits to 0. For instance, if it is not necessary to control slave stations 2, 6 and 7, merely set D1091 = 003B, and the setting method is the same as described above: Use WPL to initiate **communications > use register edit (T C D)** function to perform settings.

### Step 3: Set the master's communications station number and communications speed

- ☑ When setting the master's station number (Pr. 09-46, default is set as 100), make sure not to use the same number as a slave station.
- ☑ Set the CANopen communications speed (Pr. 09-37); regardless of whether the drive is defined as a master or slave station, the communications speed is set via this parameter.

### Step 4: Write program code

Real-time access: Can directly read/write to or from the corresponding D area.

Non real-time access:

**Read command:** Use the CANRX command for reading. M1066 will be 1 when reading is completed; M1067 will be 1 if reading is successful, and M1067 will be 0 if an error has occurred.

**Write command:** Use the CANTX command for writing. M1066 will be 1 when writing is completed; M1067 will be 1 if writing is successful, and M1067 will be 0 if an error has occurred.

**Refresh command:** Use CANFLS command to refresh (if there are RW attributes, the master will write to the slave station; if there are RO attributes, the slave station will return the read values to the master); M1066 will be 1 if refresh has been completed; M1067 will be 1 if refresh is successful, and M1067 will be 0 if an error has occurred.

#### NOTE

When using CANRX, CANTX or CANFLS, internal implementation commands will wait until M1066 is completed before executing the next CANRX, CANTX or CANFLS.

Afterwards, download program to the drive (Please note that the PLC's default communications format is ASCII 7N2 9600, and the station number is 2. The WPL must therefore be modified, and the WPL setting pathway is **settings > communications settings**)

### Step 5: Set the slave stations' station numbers, communications speed, control source, and command source

Delta's C2000 and EC series devices currently support the CANopen communications interface drive, and the corresponding slave station numbers and communications speed parameters are as follows:

	Corresponding device parameters		Value	Definition
	C2000	E-C		
Slave station address	09-36	09-20	0	Disable CANopen hardware interface
			1-127	CANopen Communication address
Communication speed	09-37	09-21	0	1Mbps
			1	500Kbps
			2	250Kbps
			3	125Kbps
			4	100Kbps
			5	50Kbps
Control source	00-21	-	3	
	-	02-01	5	
Frequency source	00-20	-	6	
	-	02-00	5	
Torque source	11-33	-	3	
	-	-	-	
Position source	11-40	-	3	
	-	-	-	

Delta's A2 Servo currently supports the CANopen communications interface, and the corresponding slave station numbers and communications speed parameters are as follows:

	Corresponding device parameters	Value	Definition
	A2		
Slave station address	03-00	1–127	CANopen Communication address
Communication speed	03-01 bit 8-11 XRX	R= 0	125Kbps
		R= 1	250Kbps
		R= 2	500Kbps
		R= 3	750Kbps
		R= 4	1Mbps
Control/command source	01-01	B	

### Step 6: Connect hardware wiring

When performing wiring, note the head and tail terminal resistance; connection methods are as follows:

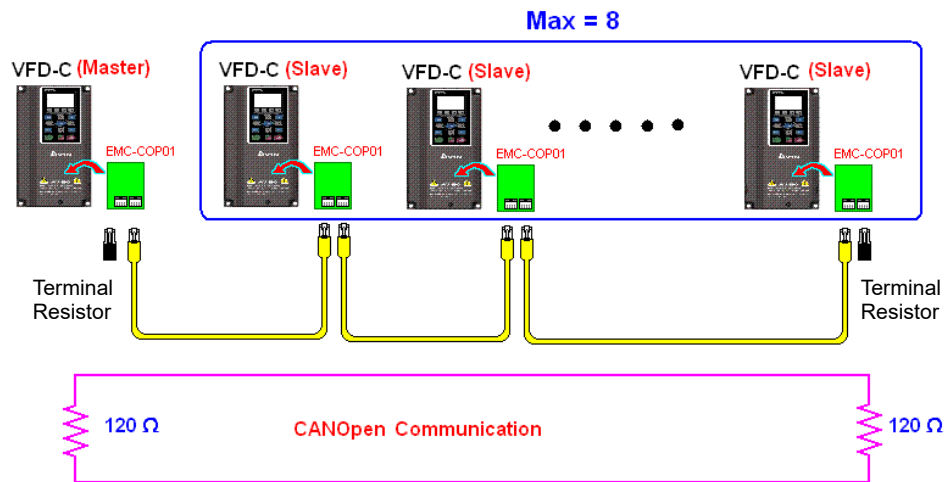

### Step 7: Initiate control

After a program has been written and downloaded, switch the PLC mode to Run. Merely turn power to master and slave stations off and then on again.

Refer to CANMasterTest 1 vs. 2 drive.dvp

#### Example

C2000 drive one-to-two control

#### Step 1: Activating CANopen Master functions

- ☑ Pr. 09-45=1 (initiates Master functions); restart power after completing setting, the status bar on the KPC-CC01 digital keypad will display "CAN Master".
- ☑ Pr. 00-02=6 reset PLC (please note that this action will reset the program and PLC registers to the default values)
- ☑ Turn power off and on again.
- ☑ Use the KPC-CC01 digital keypad to set the PLC control mode as "PLC Stop" (if a newly-introduced drive is used, the blank internal PLC program will cause a PLFF warning code to be issued).

**Step 2: Master memory correspondences**

- ☑ Enable WPL
- ☑ Use keypad set PLC mode as Stop (PLC 2)
- ☑ WPL read D1070 to D1099, D2000 to D2799
- ☑ Set D2000=10, D2100=11
- ☑ Set D2100, 2200, 2300, 2400, 2500, 2600, 2700=0
- ☑ Download D2000 to D2799 settings

**Step 3: Set the master's communications station number and communications speed**

- ☑ When setting the master's station number (Pr. 09-46, default is set as 100), make sure not to use the same number as a slave station.
- ☑ Set the CANopen communications speed as 1M (Pr. 09-37=0); regardless of whether the drive is defined as a master or slave station, the communications speed is set via this parameter.

**Step 4: Write program code**

Real-time access: Can directly read/write to or from the corresponding D area.

Non real-time access:

**Read command:** Use the CANRX command for reading. M1066 will be 1 when reading is complete; M1067 will be 1 if reading is successful, and M1067 will be 0 if an error has occurred.

**Write command:** Use the CANTX command for writing. M1066 will be 1 when writing is complete; M1067 will be 1 if writing is successful, and M1067 will be 0 if an error has occurred.

**Refresh command:** Use CANFLS command to refresh (if there are RW attributes, the master will write to the slave station; if there are RO attributes, the slave station will return the read values to the master); M1066 will be 1 if refresh has been completed; M1067 will be 1 if refresh is successful, and M1067 will be 0 if an error has occurred.

 **NOTE**

When using CANRX, CANTX or CANFLS, internal implementation commands will wait until M1066 is completed before executing the next CANRX, CANTX or CANFLS.

Afterwards, download program to the drive (Please note that the PLC's default communications format is ASCII 7N2 9600, and the station number is 2. The WPL must therefore be modified, and the WPL setting pathway is **settings > communications settings**)

**Step 5: Set the slave stations' station numbers and communications speed**

- |  |                       |
|--|-----------------------|
| Slave station no. 1: 09-37 = 0(Speed 1M) | 09-36=10(Node ID 10 ) |
| Slave station no. 2: 09-37 = 0(Speed 1M) | 09-36=10(Node ID 11 ) |

**Step 6: Connect hardware wiring**

When performing wiring, note the head and tail terminal resistance; connection methods are as follows:

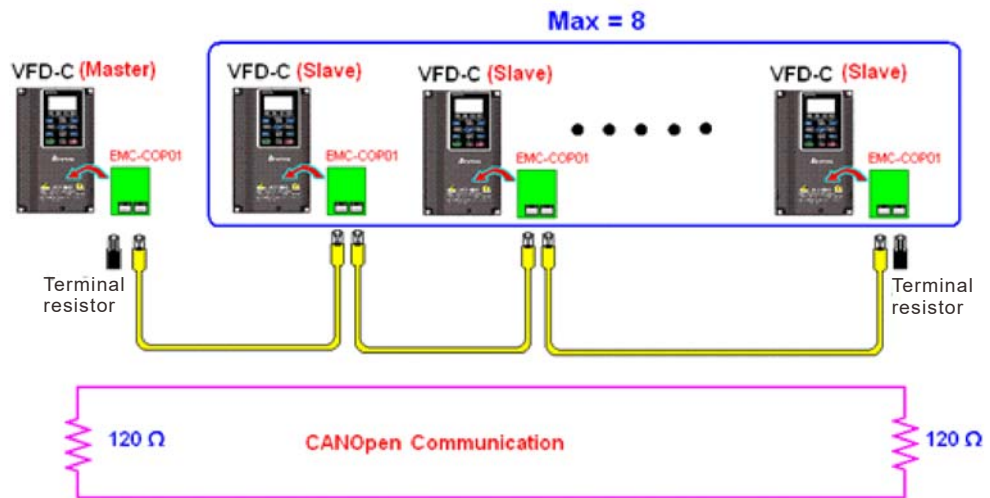

**Step 7: Initiate control**

After a program has been written and downloaded, switch the PLC mode to Run. Merely turn power to master and slave stations off and then on again.

Refer to CANMasterTest 1 vs. 2 driver.dvp

## 16-9 Explanation of various PLC mode controls (speed, torque, homing, and position)

The torque mode and position mode are based on FOC vector control and speed mode also supports FOC vector control. Control therefore cannot be performed successfully unless finishing motor parameter auto tuning ahead of time for the torque mode and position mode, and the speed mode based on FOC.

In addition, motors are classified as two types: IM and PM. For IM motors, the auto tuning of the motor parameter will be enough. For PM motors, after completing motor parameter auto tuning, the auto tuning of motor origin angle of deviation should be completed as well. Please refer to Chapter 12-1 Pr. 05-00 for detailed explanation.

※ If a PM motor belongs to Delta's ECMA series, motor parameters can be directly input from data in the servo motor catalog, and parameter study will not be needed.

Control methods and settings are explained as follows:

### Speed control:

Register table for speed mode:

#### Control special M

Special M	Description of Function	Attributes
M1025	Drive frequency = set frequency (ON) / drive frequency =0 (OFF)	RW
M1026	Drive operating direction FWD(OFF) / REV(ON)	RW
M1040	Hardware power (Servo On)	RW
M1042	Quick stop	RW
M1044	Pause (Halt)	RW
M1052	Lock frequency (lock, frequency locked at the current operating frequency)	RW

#### Status special M

Special M	Description of Function	Attributes
M1015	Frequency attained (when used together with M1025)	RO
M1056	Servo On Ready	RO
M1058	On Quick Stopping	RO

#### Control special D

Special D	Description of Function	Attributes
D1060	Mode setting (speed mode is 0)	RW

#### Status special D

Special D	Description of Function	Attributes
D1037	Converter output frequency (0.00–600.00)	RO
D1050	Actual operating mode (speed mode is 0)	RO

Speed mode control commands:

<b>FREQ(P)</b>	S1	S2	S3
	Target speed	The first acceleration time setting	The first deceleration time setting

Example of speed mode control:

Before performing speed control, if the FOC (magnetic field orientation) control method is used, setting of electromechanical parameters must first be completed.

1. Setting D1060 = 0 will shift the converter to the speed mode (default).
2. Use the FREQ command to control frequency, acceleration time, and deceleration time.
3. Set M1040 = 1, the drive will now be excited, but the frequency will be 0.
4. Set M1025 = 1, the drive frequency command will now jump to the frequency designated by FREQ, and acceleration/deceleration will be controlled on the basis of the acceleration time and deceleration time specified by FREQ.
5. M1052 can be used to lock the current operating frequency.
6. M1044 can be used to temporarily pause operation, and the deceleration method will comply with deceleration settings.
7. M1042 can be used to perform quick stop, and deceleration will be as quick as possible without giving rise to an error. (There may still be a jump error if the load is too large.)
8. Control user rights: M1040(Servo ON) > M1042(Quick Stop) >M1044(Halt) >M1052(LOCK)

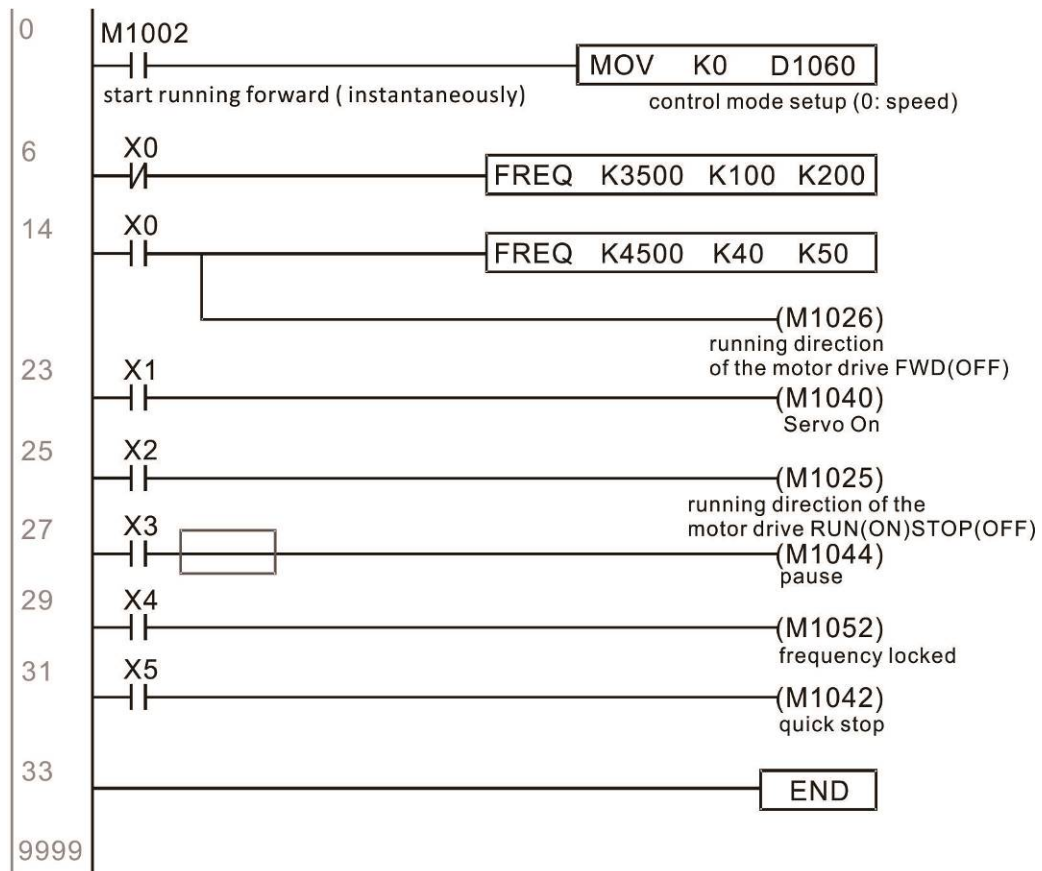



Torque control:

Register table for torque mode:

Control special M

Special M	Description of Function	Attributes
M1040	Servo On	RW

Status special M

Special M	Description of Function	Attributes
M1056	Servo On Ready	RO
M1063	Torque attained	RO

Control special D

Special D	Description of Function	Attributes
D1060	Operating mode setting (torque mode is 2)	RW

Status special D

Special D	Description of Function	Attributes
D1050	Actual operating mode (speed mode is 0)	RO
D1053	Actual torque	RO

Torque mode control commands:

**TORQ(P)**                      S1                                      S2  
 Target torque (with numbers)                      Frequency restrictions

Example of torque mode control:

The setting of electromechanical parameters involved in torque control must be completed before implementing torque control.

1. Set D1060 = 2 to change the converted to the torque mode.
2. Use the TORQ command to implement torque control and speed limits.
3. Set M1040 = 1; the drive will now be excited, and immediately jump to the target torque or speed limit. D1053 can be used to find out the current torque.

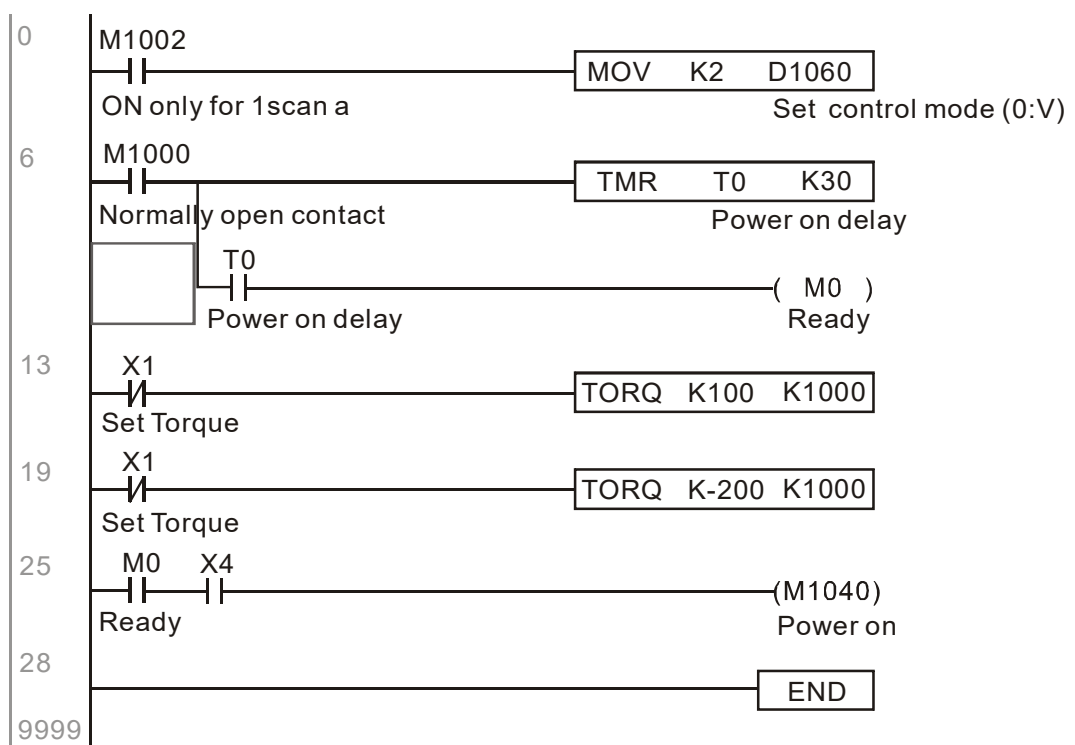



Homing control / position control:

Register table in homing mode / position mode:

Control special M

Special M	Description of Function	Attributes
M1040	Servo On	RW
M1048	Move to new position, must use control mode as position mode (D1060 = 1) and M1040 = 1	RW
M1050	Absolute position / relative position (0: relative / 1: absolute)	RW
M1055	Search for origin (home start), must use control mode as position mode (D1060 = 3) and M1040 = 1	RW

Status special M

Special M	Description of Function	Attributes
M1064	Target reached	RO
M1070	Return home complete	RO
M1071	Homing error	RO

Control special D

Special D	Description of Function	Attributes
D1060	Operating mode setting (position mode is 1, homing mode is 3)	RW

Status special D

Special D	Description of Function	Attributes
D1050	Actual operating mode (speed mode is 0)	RO
D1051	Actual position (Low word)	RO
D1052	Actual position (High word)	RO

※ D1051 and D1052 must be combined to give the actual location, and it has a serial number.

Position mode control commands:

**DPOS(P)**                      S1  
   Target (with numbers)

Example of homing mode / position mode control:

First complete setting of electromechanical parameters connected with position before implementing homing control or position control.

1. Set Pr. 00-40 to select the homing method and the corresponding limit sensors and origin. (Setting the MI function gives a reverse rotation limit of 44, a forward rotation limit of 45, and an origin proximity of 46. Because the C2000 currently only supports a Z-phase origin, the encoder card must provide Z-phase.)
2. Set D1060 = 3 to change the converter to the homing mode.
3. Set M1040 = 1  
 In the VF/SVC/VFPG mode, will enter the STANDBY mode (Pr. 01-34 can be used to access the STANDBY mode's action options).  
 In the FOC+PG mode, zero speed holding will occur
4. Set M1055 = 1, and the drive will now start to search for the origin.
5. When homing is complete, M1070 will change to ON. If you now set D1060 = 1, the control mode will switch to position mode (please note that M1040 will not change to off; this mechanical origin move).

6. The DPOS command can now be used to designate the drive's target location. M1050 or Pr. 00-12 can be used to set a change in absolute or relative position.
7. Implement M1048 Pulse ON once (must be more than 1 ms in duration), and the converter will begin to move toward the target (M1040 must be 1 to be effective). The current position can be obtained from D1051 and D1052.

Part 1: The initialization mode is defined as the "homing" mode from the beginning (set D1060 = 3). X2 is used to implement converter excitation.

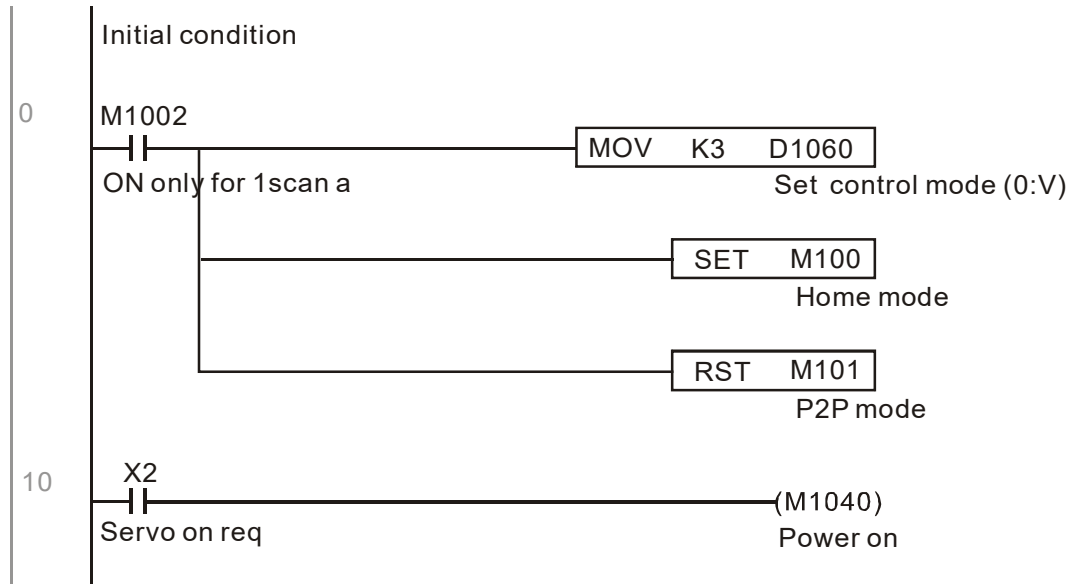

Part 2: Homing; Use X3 to trigger homing action; will automatically switch to position mode after completion.

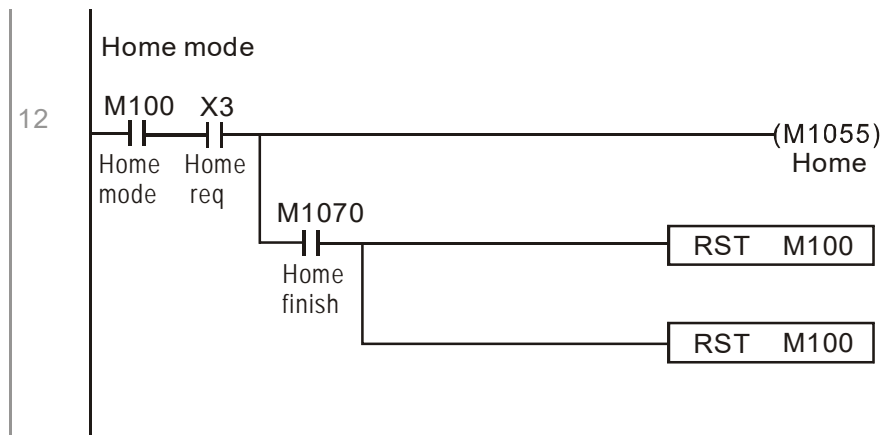

Part 3: Point-to-point movement; switch to position mode (set D1060 = 1), and move back and forth between position points. (+300000 – -300000 )

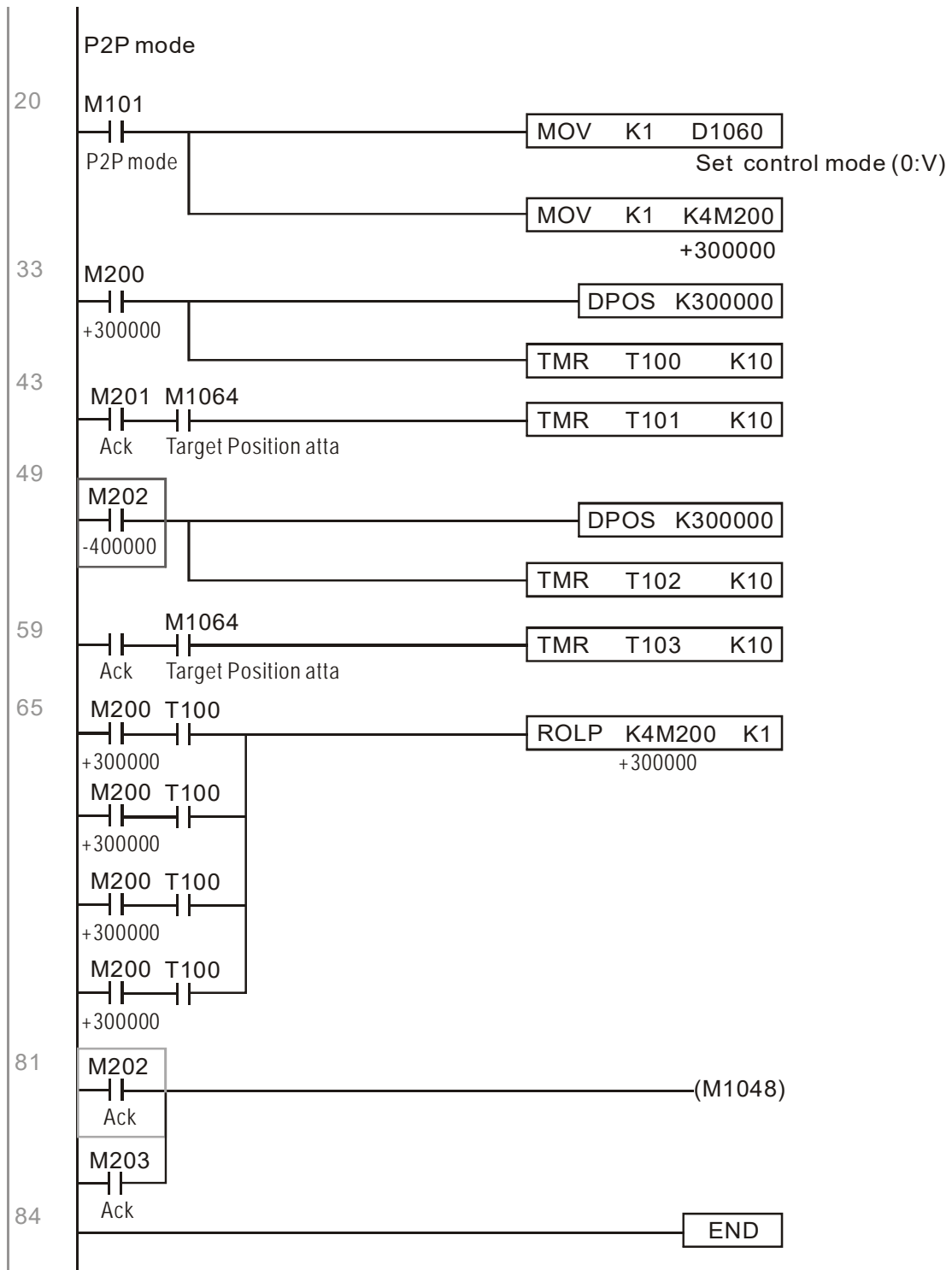

※ If homing is not needed in an application, the first and second parts can be skipped. However, the M1040 condition from Part 1 must be included, and the writing method in Part 1 involve the use of X2 to achieve direct access. In addition, when M101 is used at the beginning of Part 3 to set the control mode, it can be rewritten as M1002, which will put the PLC immediately into the position mode when it starts running.

## 16-10 Internal communications main node control

The protocol has been developed in order to facilitate the use of RS-485 instead of CANopen in certain application situations. The RS-485 protocol offers similar real-time characteristics as CANopen; this protocol can only be used on the C2000 and CT2000 devices. The maximum number of slave devices is 8.

Internal communications have a master-slave structure. The initiation method is very simple:

Slave device:

Set Pr. 09-31 = -1 to -8 in order to access 8 nodes, and set Pr. 00-20 = 1 to define the control source as RS-485 and access the reference sources that must be controlled, namely speed command (Pr. 00-21 = 2), torque command (Pr. 11-33 = 1), and position command (Pr. 11-40=2). This will complete slave device settings. (PLC functions do not need to be activated)

System

Setting the master is even simpler; it is only necessary to set Pr. 09-31 = -10, and enable the PLC.

Hardware wiring: The master and slave stations are connected via the RS-485 serial port. The C2000 provides two types of RS-485 serial port interfaces, see the figure below: (please refer to Chapter 06 “Control Terminals” concerning detailed terminal connections)

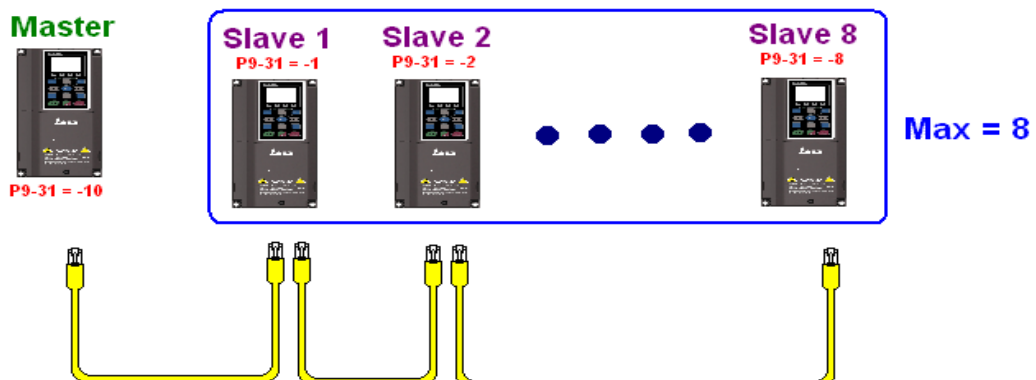
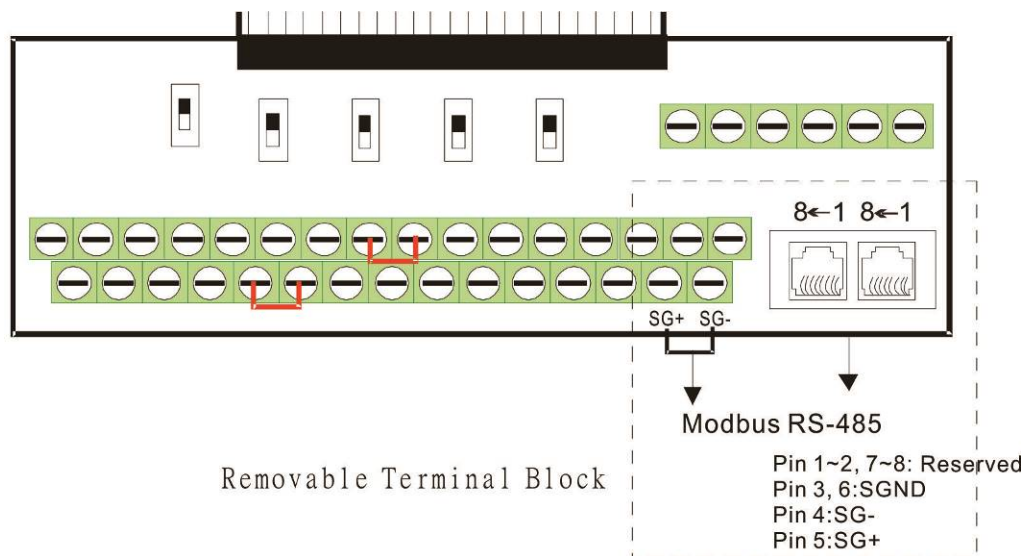

Master programming: In a program, D1110 can be used to define a slave station to be controlled (1–8, if set as 0, can jump between 8 stations). Afterwards, M1035 is set as 1, and the memory positions of the master and slave stations will correspond. At this time, it is only necessary to send commands to the correlation slave station address to control that station. The following is a register table connected with internal communications:

Control special M

Special M	Description of Function	Attributes
M1035	Initiates internal communications control	RW

Control special D

Special D	Description of Function	Attributes
D1110	Internal node communications number 1–8 (set the station number of the slave station to be controlled)	RW

Special D	Description of Function							Attributes
	Definition	bit	User rights	Speed mode	Location mode	Torque mode	Homing mode	
D1120 + 10*N	Internal node N control command	0	4	Command functions	-	-	Homing Origin	RW
		1	4	Reverse rotation requirements	Immediate change	-	-	
		2	4	-	-	-	-	
		3	3	Temporary pause	Temporary pause	-	-	
		4	4	Frequency locking	-	-	Temporary pause	
		5	4	JOG	-	-	-	
		6	2	Quick Stop	Quick Stop	Quick Stop	Quick Stop	
		7	1	Servo ON	Servo ON	Servo ON	Servo ON	
		11–8	4	Speed interval switching	Speed interval switching	-	-	
		13–12	4	Deceleration time change	-	-	-	
		14	4	Enable Bit 13–8	Enable Bit 13–8	-	-	
15	4	Clear error code	Clear error code	Clear error code	Clear error code			
D1121 + 10*N	Internal node N control mode			0	1	2	3	RW
D1122 + 10*N	Internal node N reference command L			Speed command (no number)	Position command (with numbers)	Torque command (with numbers)	-	RW
D1123 + 10*N	Internal node N reference command H			-		Speed limit	-	RW

※ N = 0–7

Status special D

Special D	Description of Function	Attributes
D1115	Internal node synchronizing cycle (ms)	RO
D1116	Internal node error (bit0 = slave device 1, bit1 = slave device 2,...bit7 = slave device 8)	RO
D1117	Internal node online correspondence (bit0 = slave device 1, bit1 = slave device 2,...bit7 = slave device 8)	RO

Special D	Description of Function					Attributes
	bit	Speed mode	Location mode	Torque mode	Homing mode	
D1126 + 10*N	0	Frequency command arrival	Position command attained	Torque command attained	Zero command completed	RO
	1	Clockwise	Clockwise	Clockwise	Clockwise	
		Counterclockwise:	Counterclockwise:	Counterclockwise:	Counterclockwise:	
	2	Warning	Warning	Warning	Warning	
	3	Error	Error	Error	Error	
	5	JOG				
	6	Quick Stop	Quick Stop	Quick Stop	Quick Stop	
7	Servo ON	Servo ON	Servo ON	Servo ON		
D1127 + 10*N		Actual frequency	Actual position (with numbers)	Actual torque (with numbers)	-	RO
D1128 + 10*N		-		-	-	

※ N = 0 - 7

Example: Assume it is desired to control slave station 1 operation at frequencies of 30.00Hz and 60.00 Hz, status, and online node correspondences:

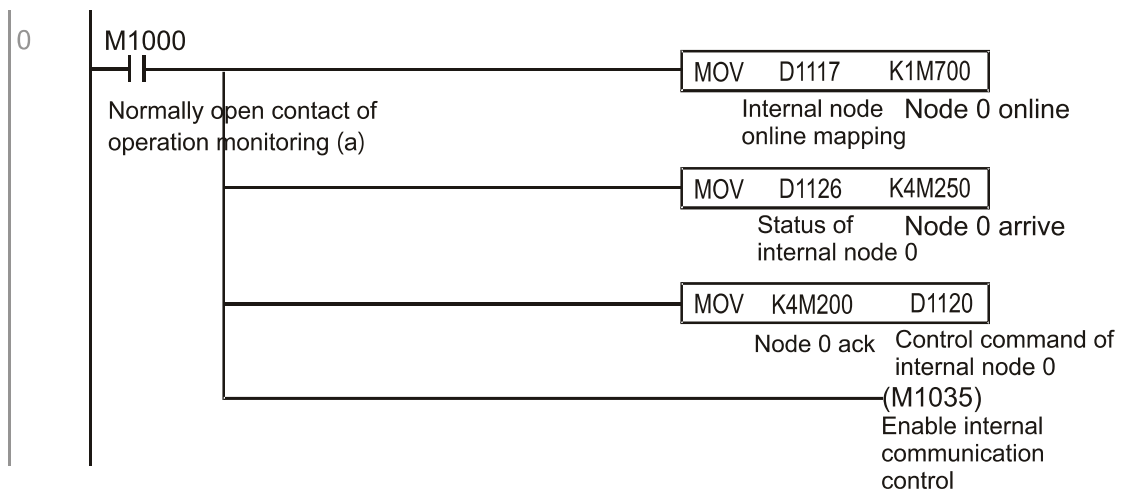

When it is judged that slave station 1 is online, delay 3 sec. and begin control

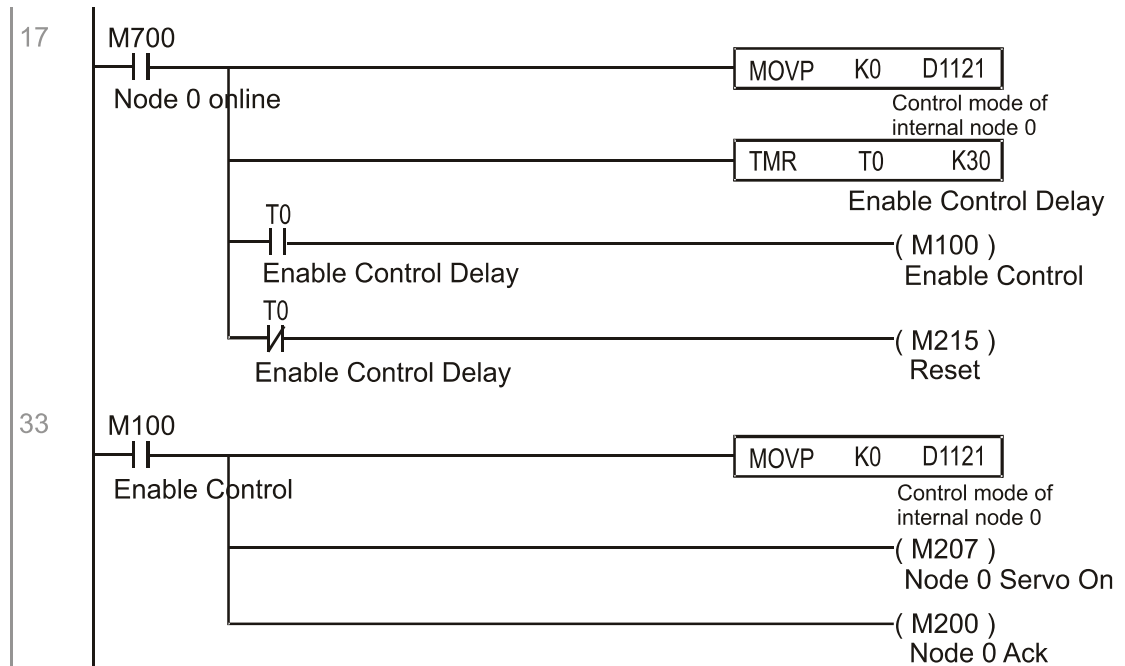

It is required slave station 1 maintains forward rotation at 30.00Hz for 1 sec., and maintains reverse rotation at 60.00 Hz for 1 sec., and repeat this cycle continuously.

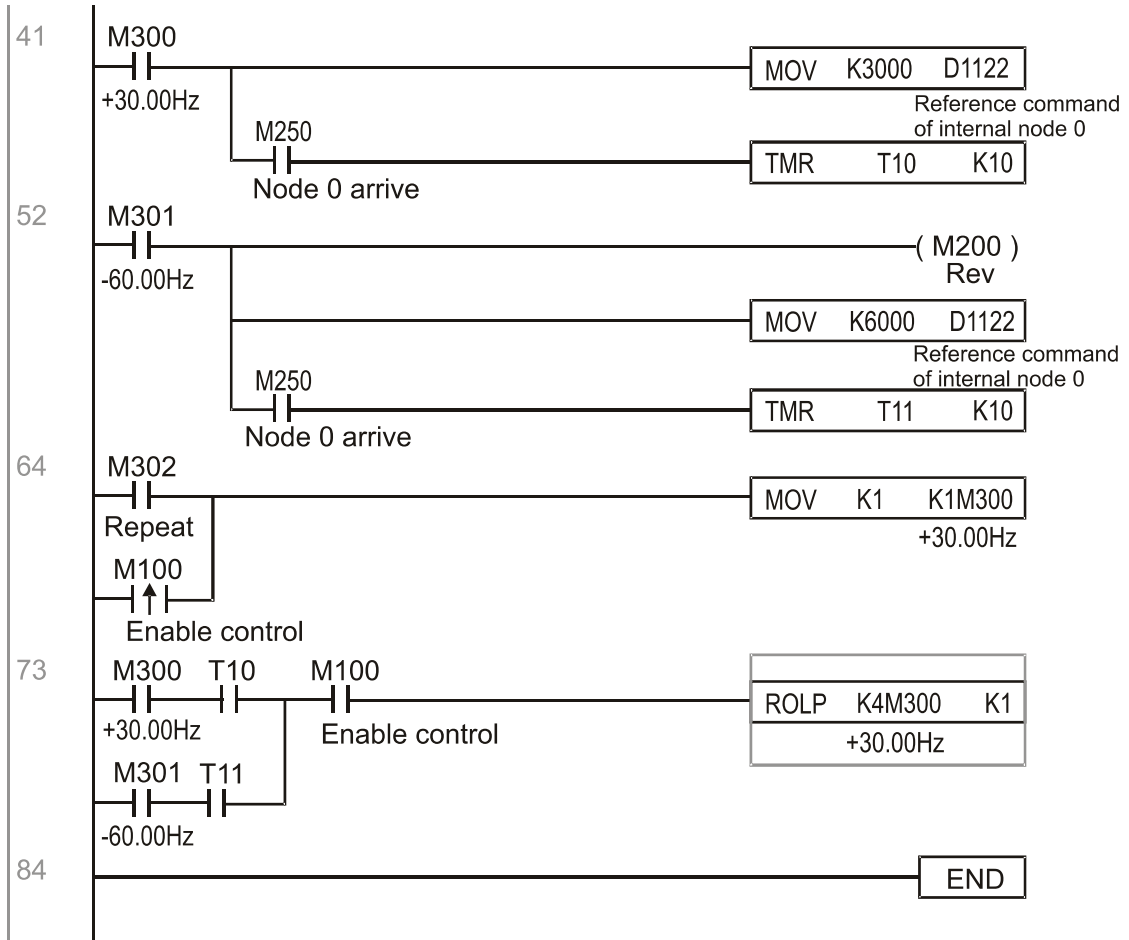

## 16-11 Count function using MI8

### 16-11-1 High-speed count function

The C2000's MI8 supports one-way pulse counting, and the maximum speed is 100K. The starting method is very simple, and only requires setting M1038 to begin counting. The 32 bit count value is stored on D1054 and D1055 in non-numerical form. M1039 can reset the count value to 0.

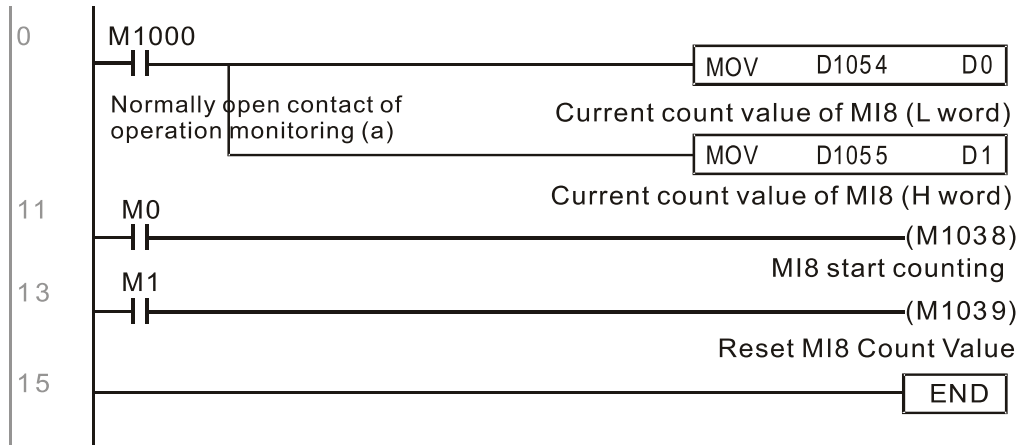

※ When the PLC program defines MI8 for use as a high-speed counter, and also for use in PLC procedures, it must be written to M1038 or M1039, and the original MI8 functions will be disabled.

### 16-11-2 Frequency calculation function

Apart from high-speed counting, the C2000's MI8 can also convert a received pulse to frequency. The following figure shows that there is no conflict between frequency conversion and count calculations, which can be performed simultaneously.

PLC speed calculation formula

D1057 Speed

D1058 Interval between calculations

D1059 Decimal places

Assuming that there are 5 input pulses each second, (see figure below) we set D1058=1000ms=1.0 sec. as the calculation interval. This enables five pulses to be sent to the converter each second.

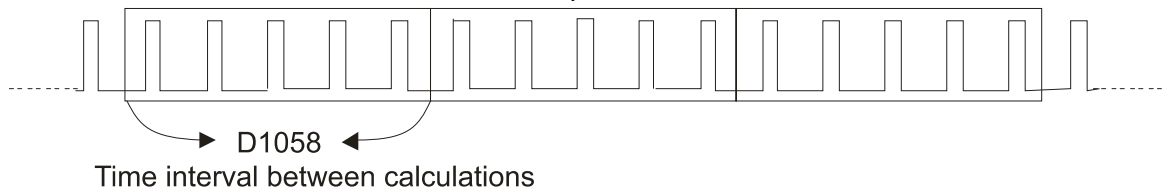

Time interval between calculations

Assuming that each 5 pulses correspond to 1Hz, we set D1057=5.

Assuming that we wish to display numbers to two decimal places, we set D1059=2, which is also 1.00Hz. The numerical value displayed at D1056 is 100. For simplicity, the D1056 conversion formula can be expressed as in the following table:

$$D1056 = \frac{\text{Pulses per second}}{D1057} \times \frac{1000}{D1058} \times 10^{D1059}$$



## 16-12 Modbus Remote IO Control Applications (use MODRW)

The C2000's internal PLC supports 485 read/write functions, which can be realized using the MODRW command. However, the 485 serial port must be defined as available for the PLC's 485 use before writing a program, and the Pr. 09-31 must be set as -12. After completing settings, the standard functions defined by 485 can be used to implement read/write commands at other stations. Communications speed is defined by parameter 09-01, the communications format is defined by Pr. 09-04, and the PLC's current station number is defined by Pr. 09-35. The C2000 currently supports the functions read coil (0x01), read input (0x02), read register (0x03), write to single register (0x06), write to several coils (0x0F), and write to several registers (0x10). Explanations and the usage of these functions are provided as follows:

MODRW command					General meaning	Slave device is Delta's PLC meaning	Slave device is Delta's converter meaning
S1	S2	S3	S4	S5			
Node ID	Command	Address	Return: D area	Length			
K3	H01	H500	D0	K18	Read coil (bit)	Read 18 bits of data corresponding to slave station 3 PLC Y0 to Y21. This data is stored by bit 0 to 15 of the this station's D0 and bit 0 to bit 3 of D1.	Does not support this function
K3	H02	H400	D10	K10	Read input (bit)	Read 10 bits of data corresponding to slave station 3 PLC X0 to X11. This data is stored by bit 0 to 9 of this station's D10.	Does not support this function
K3	H03	H600	D20	K3	Read register (word)	Read 3 words of data corresponding to slave station 3 PLC T0 to T2. This data is stored by D20 to D22.	Read 3 words of data corresponding to slave station 3 converter parameters 06-00 to 06-02. This data is stored by D20 to D22
K3	H06	H610	D30	XX	Write to single register (word)	Write slave station 3 PLC's T16 to this station's D30 value	Write slave station 3 converter 06 to 16 parameter to this station's D30 value
K3	H0F	H509	D40	K10	Write to multiple coils (Bit)	Write slave station 3 PLC's Y11 to Y22 to bit 0 to 9 of D40.	Does not support this function
K3	H10	H602	D50	K4	Write to multiple registers (word)	Write slave station 3 PLC's T2 to T5 to D50 to D53	Write slave station 3 converter 06-02 to 06-05 parameters to this station's D50 to D53

※ XX indicates doesn't matter

After implementing MODRW, the status will be displayed in M1077 (485 read/write complete), M1078 (485 read/write error), and M1079 (485 read/write time out). M1077 is defined so as to immediately revert to 0 after the MODRW command has been implemented. However, any of three situations—a report of no error, a data error report, or time out with no report—will cause the status of M1077 to change to On.

Example program: Testing of various functions

At the start, will cause the transmitted time sequence to switch to the first data unit.

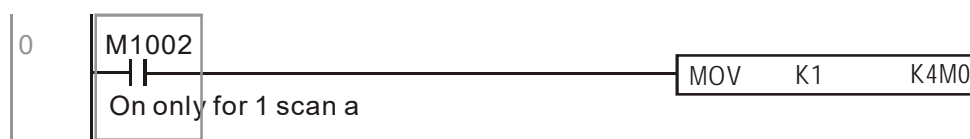

When the reported message indicates no error, it will switch to the next transmitted command

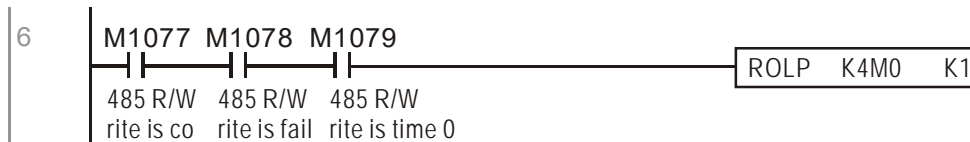

If time out occurs or an error is reported, the M1077 will change to On. At this time, after a delay of 30 scanning cycles, it will re-issue the original command once

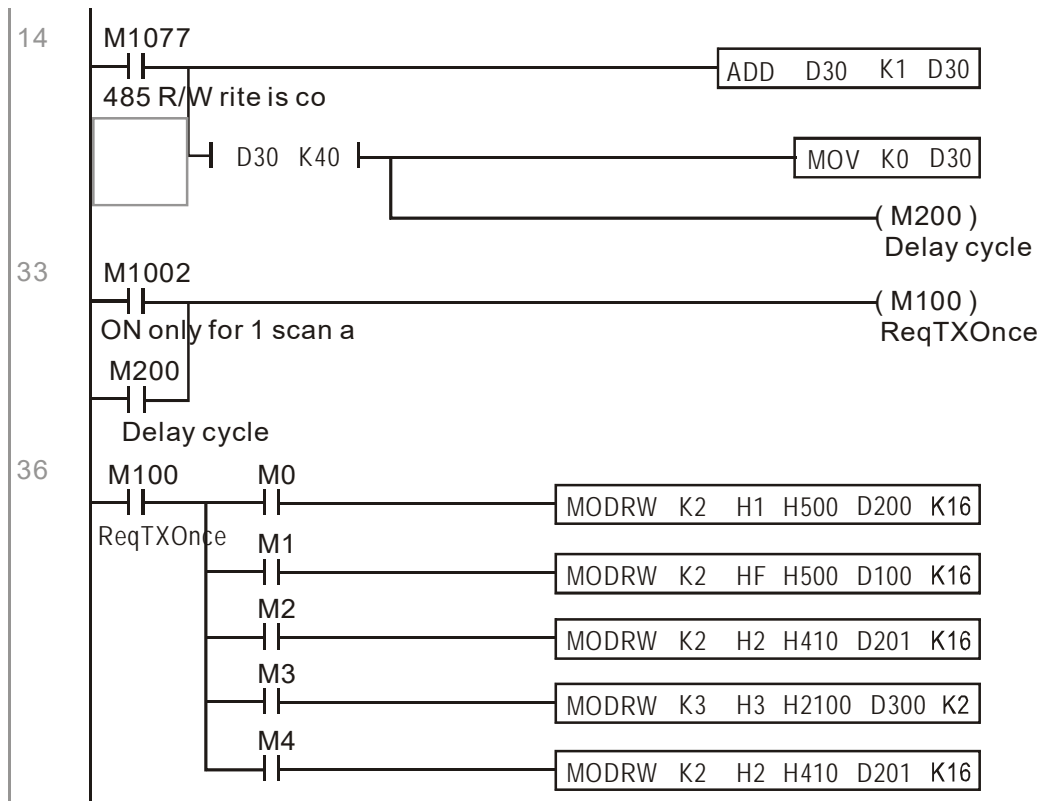

It will repeat after sending all commands

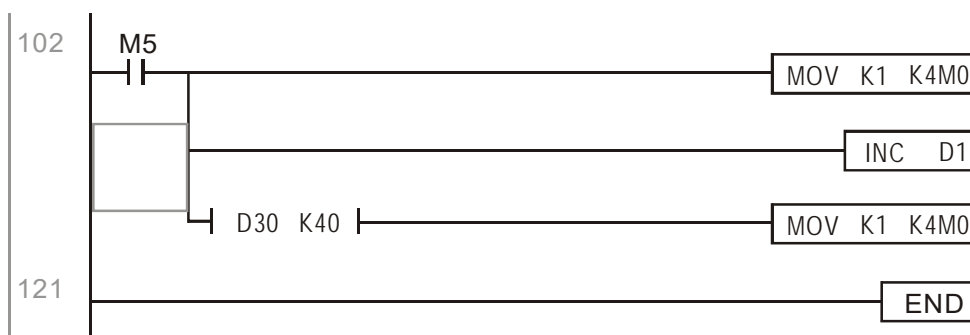

Practical applications:

Actual use to control the RTU-485 module.

Step 1: Set the communications format. Assume that the communications format is 115200, 8,N,2, RTU

C2000 : The default PLC station number is set as 2 (09-35)

Pr. 09-31=-12 (COM1 is controlled by the PLC ), Pr. 09-01=115.2 (The communications speed is 115200 )

Pr. 09-04=13 (The format is 8,N,2, RTU)

RTU-485: The station number = 8 (give example)

ID7	ID6	ID5	ID4	ID3	ID2	ID1	ID0
0	0	0	0	1	0	0	0

PA3	PA2	PA1	PA0	DR2	DR1	DR0	A/R
1	0	0	0	1	1	1	0

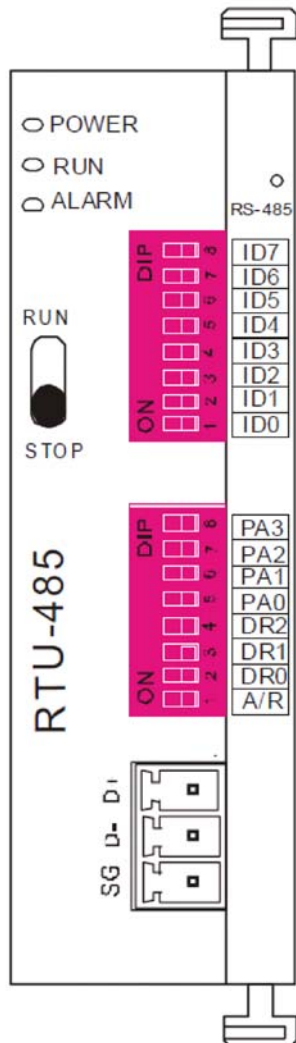

Communication station #:  
ID0~ ID7 are defined as  $2^0, 2^1, 2^2 \dots 2^6, 2^7$

Communication protocol

PA3	PA2	PA1	PA0	A/R	Communication Protocol
OFF	OFF	OFF	OFF	ON	7,E,1 · ASCII
OFF	OFF	OFF	ON	ON	7,O,1 · ASCII
OFF	OFF	ON	OFF	ON	7,E,2 · ASCII
OFF	OFF	ON	ON	ON	7,O,2 · ASCII
OFF	ON	OFF	OFF	ON	7,N,2 · ASCII
OFF	ON	OFF	ON	ON	8,E,1 · ASCII
OFF	ON	ON	OFF	ON	8,O,1 · ASCII
OFF	ON	ON	ON	ON	8,N,1 · ASCII
ON	OFF	OFF	OFF	ON	8,N,2 · ASCII
OFF	ON	OFF	ON	OFF	8,E,1 · RTU
OFF	ON	ON	OFF	OFF	8,O,1 · RTU
OFF	ON	ON	ON	OFF	8,N,1 · RTU
ON	OFF	OFF	OFF	OFF	8,N,2 · RTU

DR2	DR1	DR0	Communication Speed
OFF	OFF	OFF	1,200 bps
OFF	OFF	ON	2,400 bps
OFF	ON	OFF	4,800 bps
OFF	ON	ON	9,600 bps
ON	OFF	OFF	19,200 bps
ON	OFF	ON	38,400 bps
ON	ON	OFF	57,600 bps
ON	ON	ON	115,200 bps

Step 2: Install control equipment. We sequentially connect a DVP16-SP (8 IN 8 OUT), DVP-04AD (4 channels AD), DVP02DA (2 channels DA), and DVP-08ST (8 switches) to the RTU-485.

The following corresponding locations can be obtained from the RTU-485's configuration definitions:

Module	Terminals	485 Address
DVP16-SP	X0-X7	0400H-0407H
	Y0-Y7	0500H-0507H
DVP-04AD	AD0-AD3	1600H-1603H
DVP02DA	DA0-DA1	1640H-1641H
DVP-08ST	Switch 0-7	0408H-040FH

Step 3: Physical configuration

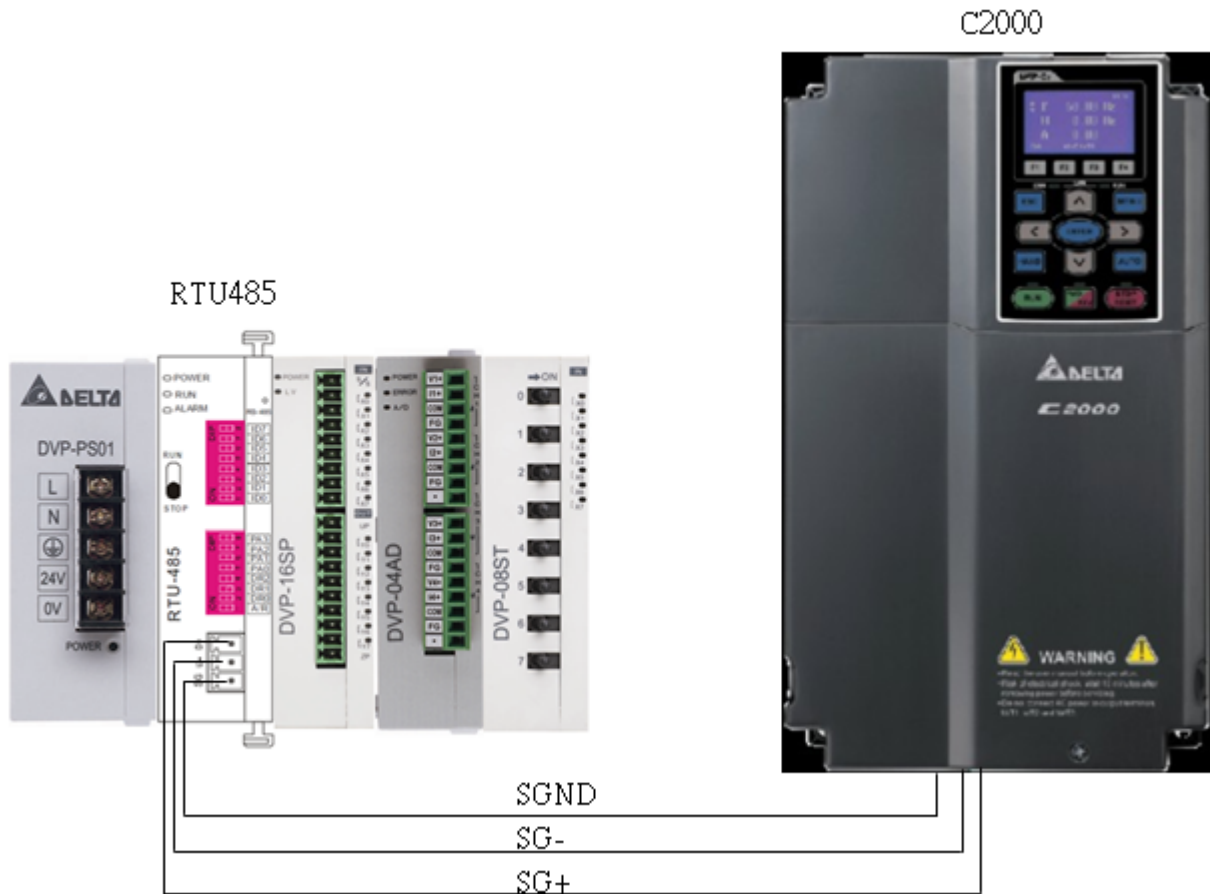

Step 4: Write to PLC program

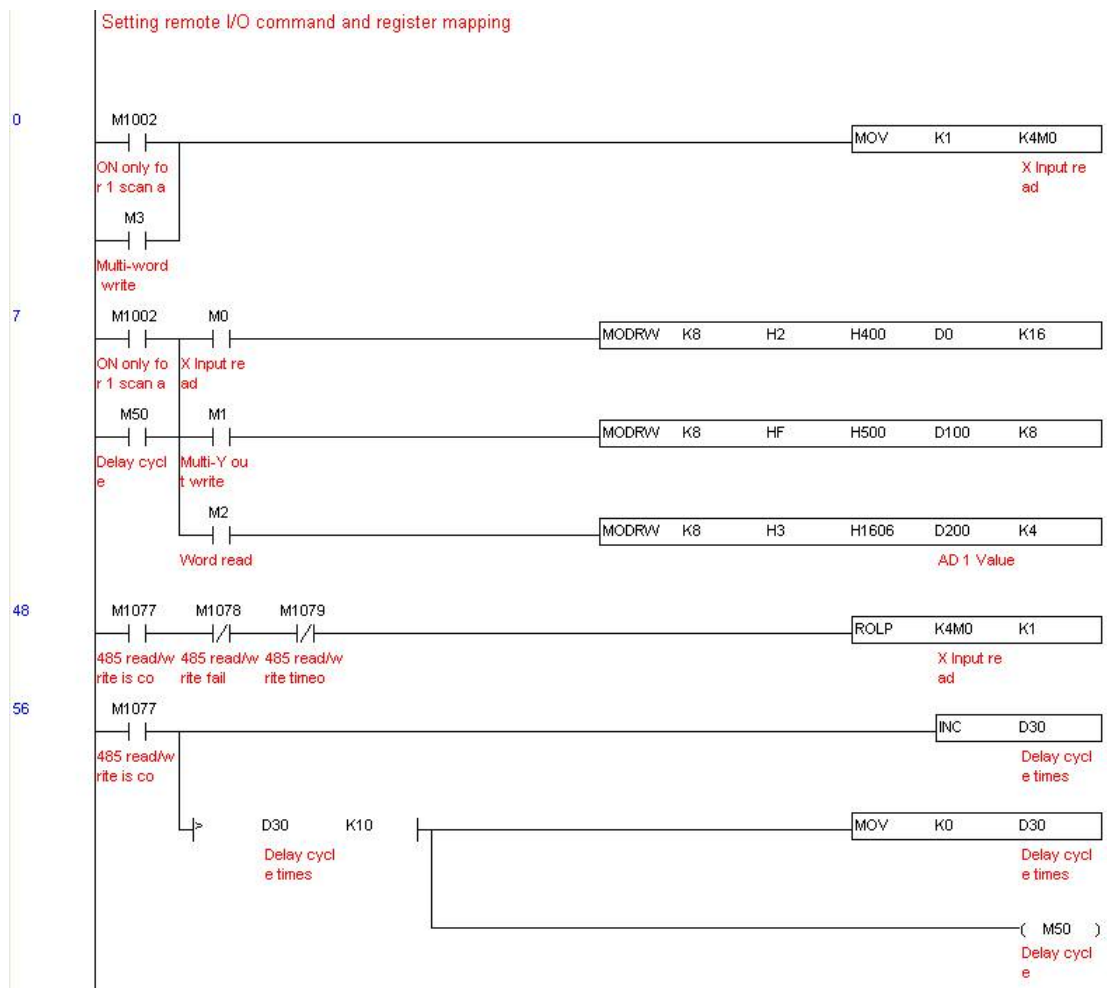

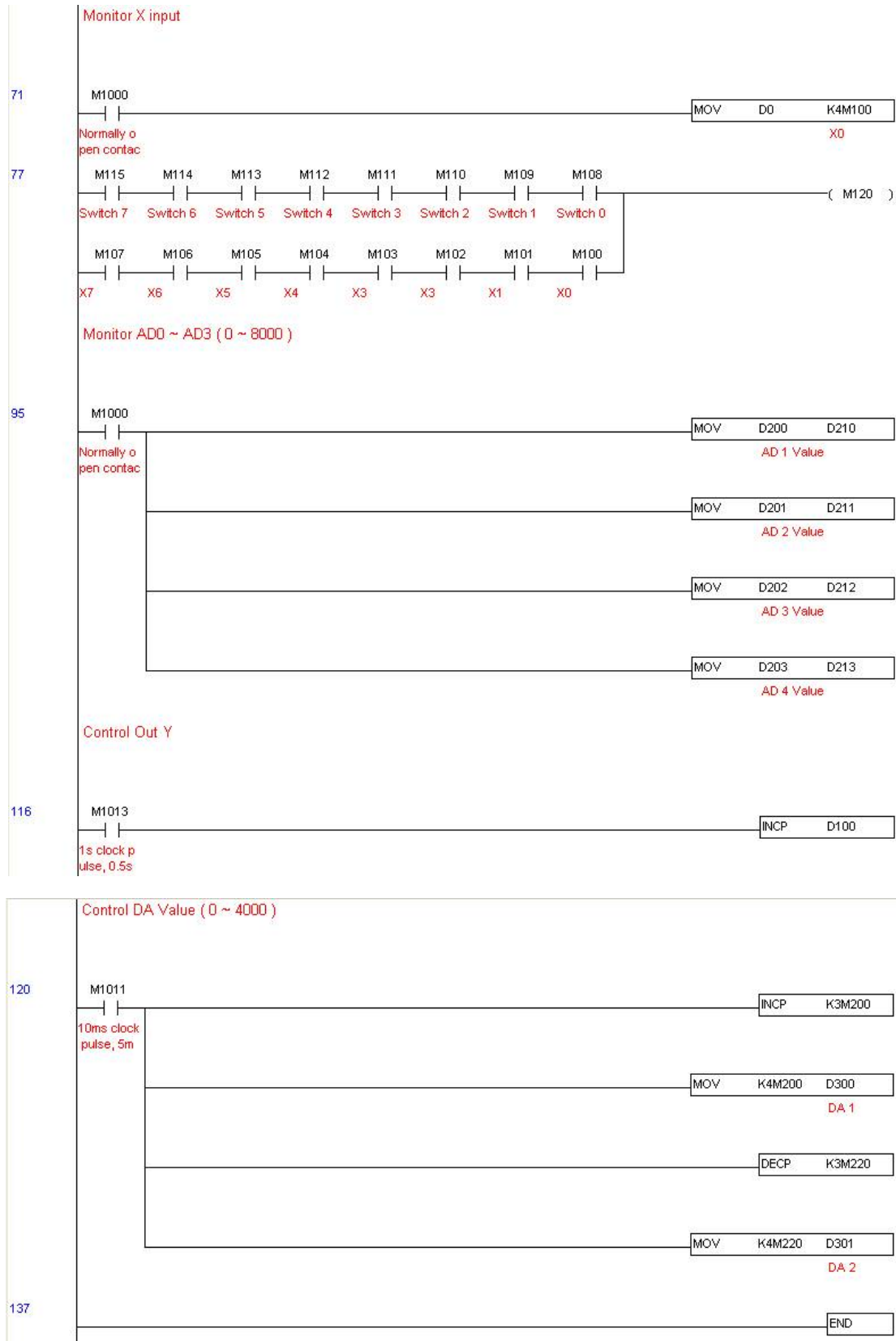

Step 5: Actual testing situation:

I/O testing: When the switch is activated, it can be discovered that the display corresponds to M115–M108. Furthermore, it can be seen that one output point light is added every 1 sec. (the display uses a binary format)

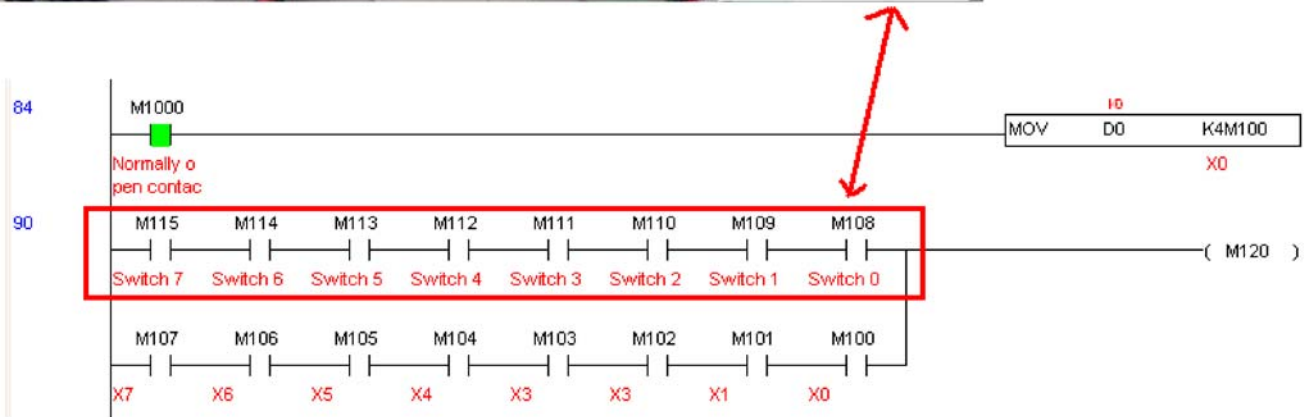
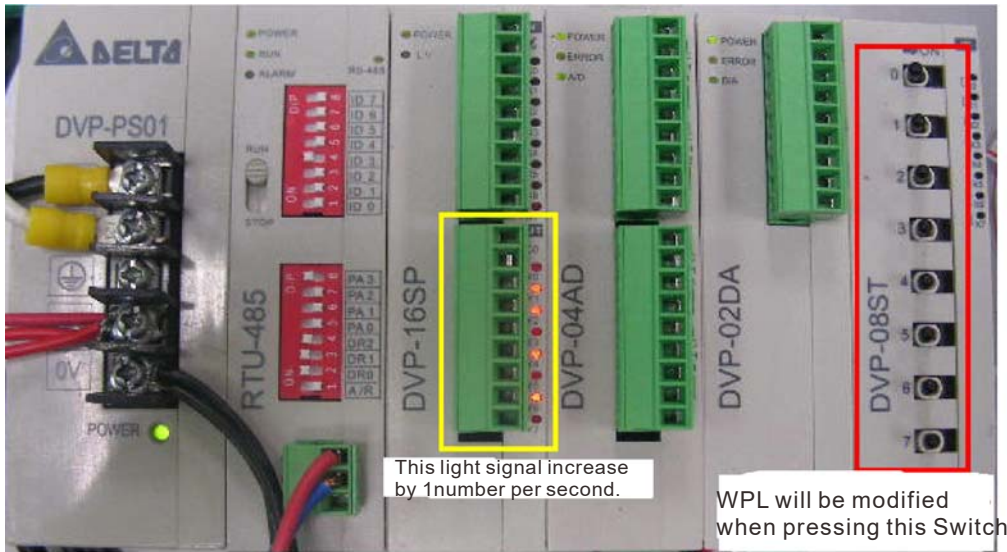

AD DA testing: It can be discovered that D200 and D201 are roughly twice the D300, and continue to increase progressively. For their part, the D202 and D203 are roughly twice the D301, and continue to decrease progressively.

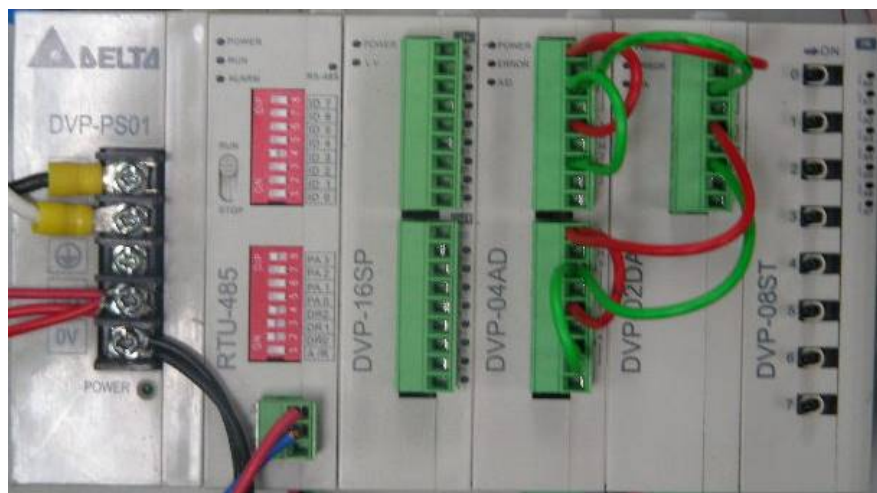

AD 1 ┌ DA1  
AD 2 └

AD 3 ┌ DA 2  
AD 4 └

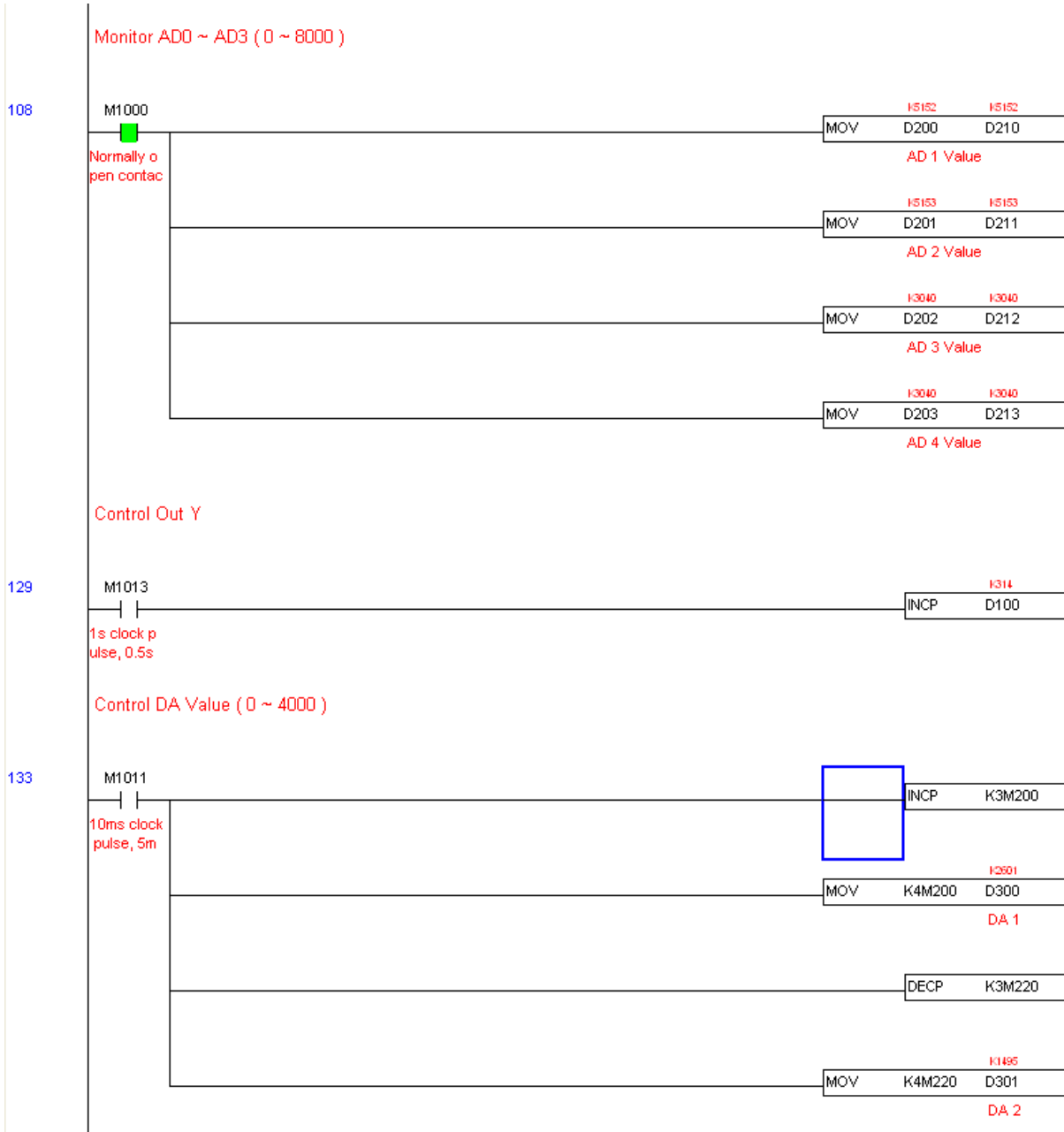



## 16-13 Calendar functions

The C2000's internal PLC includes calendar functions, but these may only be used when a keypad (KPC-CC01) is connected, otherwise the function cannot be used. Currently-supported commands include TCMP (comparison of calendar data), TZCP (calendar data range comparison), TADD (calendar data addition), TSUB (calendar data subtraction), and TRD (calendar reading). Please refer to the explanation of relevant commands and functions for the usage of these commands.

In real applications, the internal PLC can judge whether calendar function have been activated; if they have been activated, calendar warning codes may be displayed in some situations. The basis for whether a calendar function has been activated is whether the program has written the calendar time (D1063 to D1069) in connection with the foregoing calendar commands or programs.

The calendar's time display is currently assigned to D1063 to D1069, and is defined as follows:

Special D	Item	Content	Attributes
D1063	Year (Western)	20xx (2000–2099)	RO
D1064	Weeks	1–7	RO
D1065	Month	1–12	RO
D1066	Day	1–31	RO
D1067	Hour	0–23	RO
D1068	Minute	0–59	RO
D1069	Second	0–59	RO

Calendar-related special M items are defined as follows:

Special D	Item	Attributes
M1068	Calendar time error	RO
M1076	Calendar time error or refresh time out	RO
M1036	Ignore calendar warning	RW

\*When a program writes to the commands TCMP, TZCP, TADD, or TSUB, if it is discovered that a value exceeds the reasonable range, M1026 will be 1.

\*When the keypad display is PLra (RTC correction warning) or PLrt (RTC time out warning), M1076 will be ON.

\*When M1036 is 1, the PLC will ignore the calendar warning.

Calendar trigger warning code is defined as follows:

Warning	Description	Reset approach	Whether it affects PLC operation
PLra	Calendar time correction	Requires power restart	Will not have any effect
PLrt	Calendar time refresh time out	Requires power restart	Will not have any effect

\*When the PLC's calendar functions are operating, if the keypad is replaced with another keypad, it will jump to PLra.

\*When it is discovered at startup that the keypad has not been powered for more than 7 days, or the time is wrong, PLra will be triggered.

\*When it is discovered that the C2000 has no keypad in 10 sec. after startup, PLrt will be triggered.



\*If the keypad is suddenly pulled out while the calendar is operating normally, and is not reconnected for more than 1 minute, PLRt will be triggered.

Practical applications:

We will perform a demo of simple applications.

We first correct the keypad time. After pressing Menu on the keypad, select the 9th time setting option. After selection, set the current time.

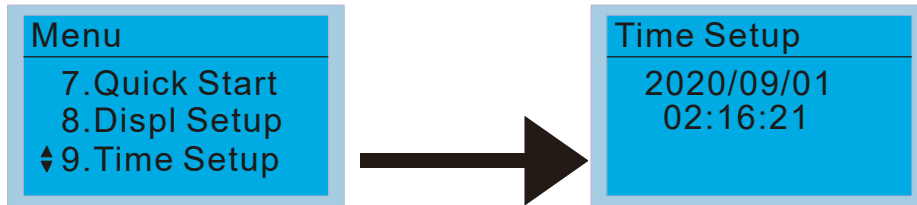

We set converter on during the period of 8:00–17:20, which allows us to write the following example

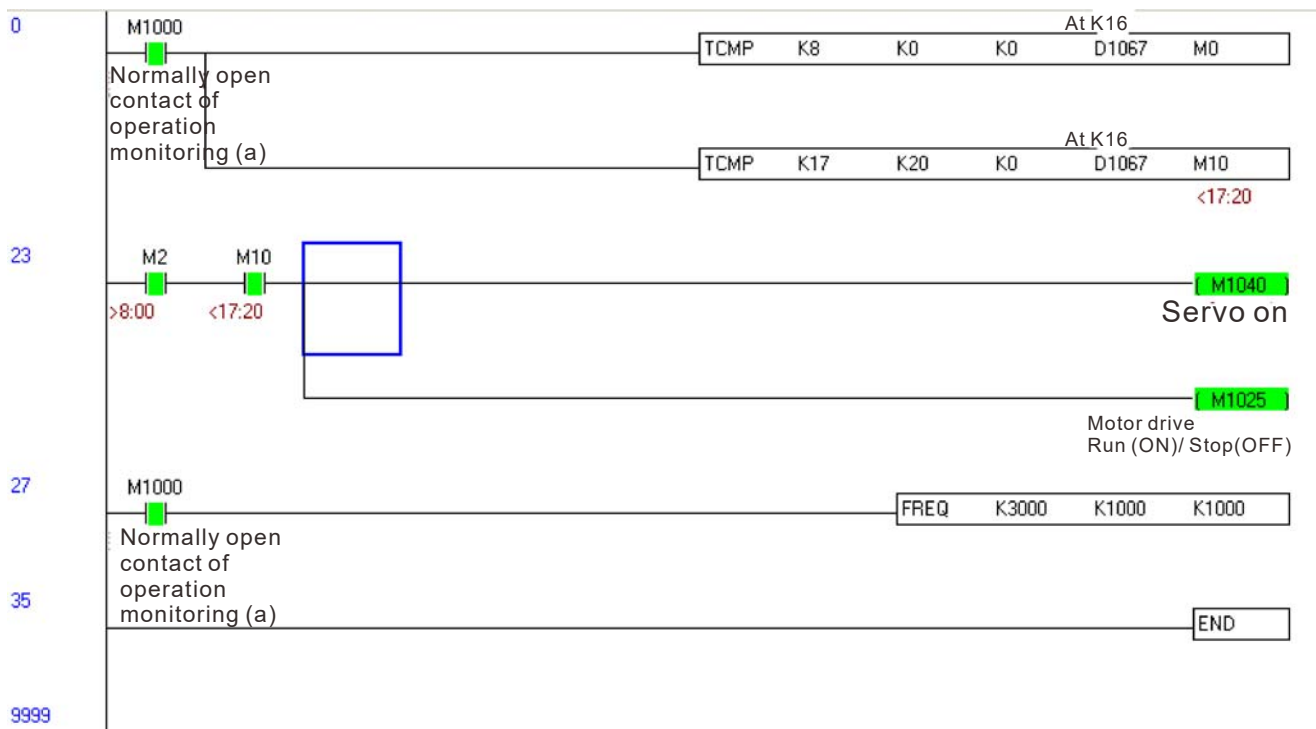

# ***Chapter 17 Safe Torque Off Function***

---

17-1 The Drive Safety Function Failure Rate

17-2 Safe Torque Off Terminal Function Description

17-3 Wiring Diagram

17-4 Parameter

17-5 Operating Sequence Description

17-6 New Error Code for STO Function

## 17-1 The Drive Safety Function Failure Rate

Item	Definition	Standard	Performance
SFF	Safe Failure Fraction	IEC61508	Channel 1: 80.08% Channel 2: 68.91%
HFT (Type A subsystem)	Hardware Fault Tolerance	IEC61508	1
SIL	Safety Integrity Level	IEC61508	SIL 2
		IEC62061	SILCL 2
PFH	Average frequency of dangerous failure [h <sup>-1</sup> ]	IEC61508	$9.56 \times 10^{-10}$
PFD <sub>av</sub>	Probability of Dangerous Failure on Demand	IEC61508	$4.18 \times 10^{-6}$
Category	Category	ISO13849-1	Category 3
PL	Performance level	ISO13849-1	d
MTTF <sub>d</sub>	Mean time to dangerous failure	ISO13849-1	High
DC	Diagnostic coverage	ISO13849-1	Low

## 17-2 Safety Torque Off Terminal Function Description







The Safe Torque Off function (STO) is to cut off the power supply to motor through the hardware, thereby the motor couldn't produce torque.

The STO function controls the motor current driving signal through two hardware circuits respectively, and thus cut off the inverter power module output in order to achieve the status of safety stop.

Operation principle Description as following table 1:

Table 1: Terminal operation description

Signal	Channel	Photo-coupler status			
STO signal	STO1–SCM1	ON (High)	ON (High)	OFF (Low)	OFF (Low)
	STO2–SCM2	ON (High)	OFF (Low)	ON (Low)	OFF (Low)
Driver Output status		Ready	STL2 mode (Torque output off)	STL1 mode (Torque output off)	STO mode (Torque output off)

-  STO means Safe Torque Off
-  STL1–STL3 means Safe Torque Off hardware abnormal.
-  STL3 means STO1–SCM1 and STO2–SCM2 internal circuit detected abnormal.
-  STO1–SCM1 ON (High): means STO1–SCM1 has connection to a +24V<sub>DC</sub> power supply.
-  STO2–SCM2 ON (High): means STO2–SCM2 has connection to a +24V<sub>DC</sub> power supply.
-  STO1–SCM1 OFF (Low): means STO1–SCM1 hasn't connection to a +24V<sub>DC</sub> power supply.
-  STO2–SCM2 OFF (Low): means STO2–SCM2 hasn't connection to a +24V<sub>DC</sub> power supply.

### 17-3 Wiring Diagram

17-3-1 Internal STO circuit as below:

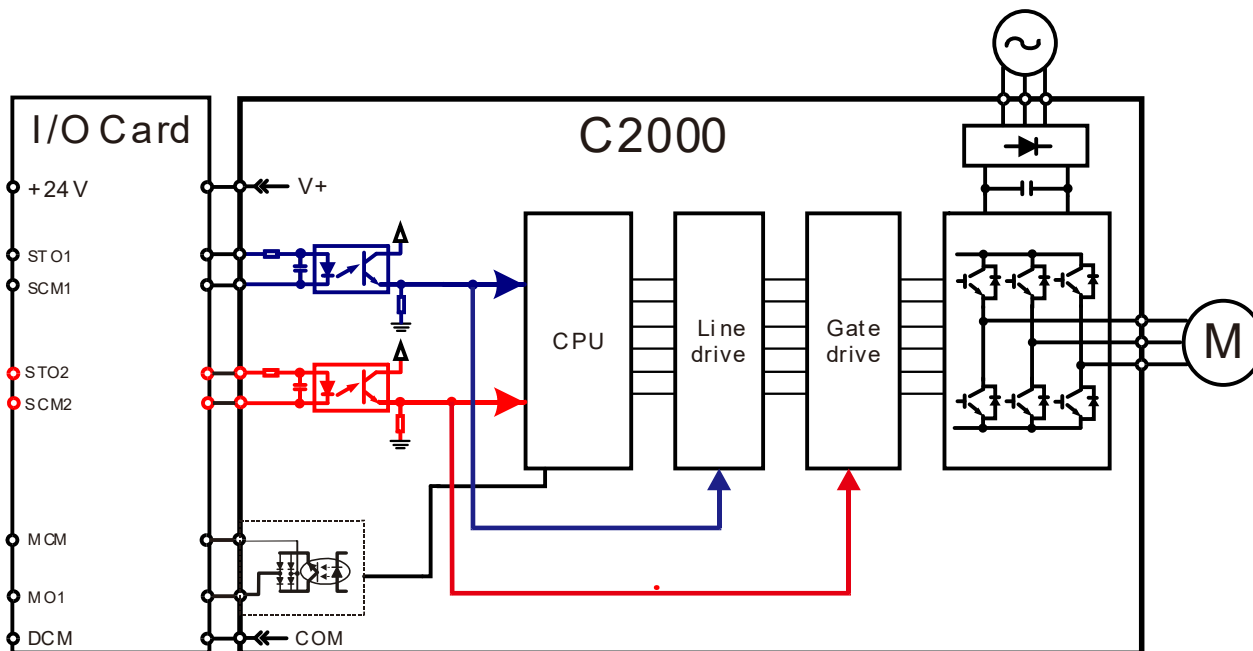

17-3-2 In the figure below, the factory setting for +24V-STO1-STO2 and SCM1-SCM2-DCM is short-circuited:

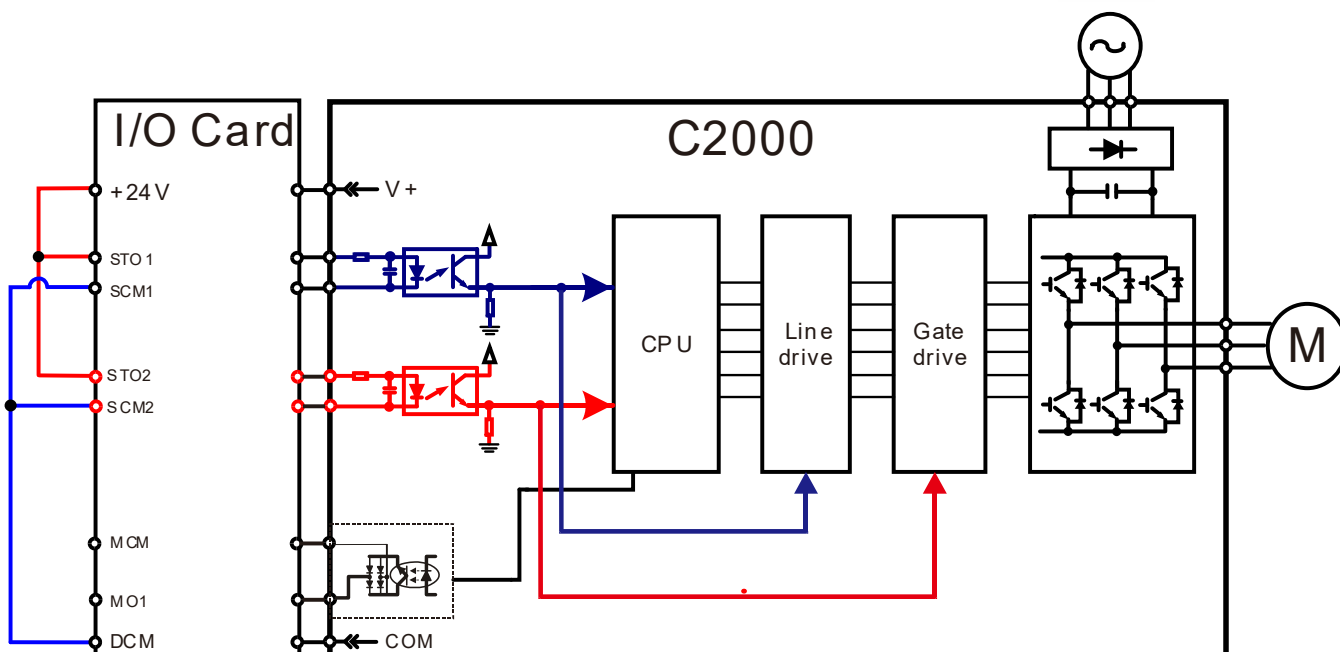

17-3-3 The control loop wiring diagram:

1. Remove the short-circuit of +24V-STO1-STO2 and DCM-SCM1-SCM2.
2. The wiring as below diagram. The ESTOP switch must at Close status in normal situation and drive will be able to Run.
3. STO mode, switch ESTOP open. Drive output stop and keypad display STO.

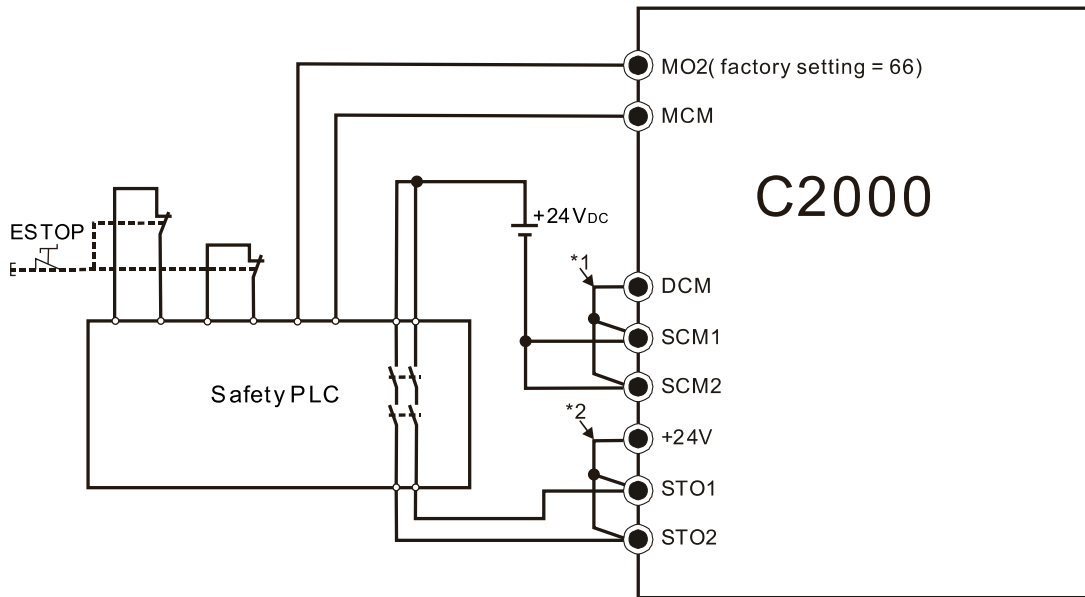

**NOTE**

- \* 1: Factory short-circuit of DCM-SCM1-SCM2. Remove the short-circuit to use the Safety function.
- \* 2: Factory short-circuit of +24V-STO1-STO2. Remove the short-circuit to use the Safety function.

## 17-4 Parameters

⚡ **06-44** STO Alarm Latch Default: 0

Settings 0 : STO Alarm Latch  
1 : STO Alarm no Latch

---

- 📖 Pr. 06-44=0 STO Alarm Latch: after the reason of STO Alarm is cleared, a Reset command is needed to clear the STO Alarm.
- 📖 Pr. 06-44=1 STO Alarm no Latch: after the reason of STO Alarm is cleared, the STO Alarm will be cleared automatically.
- 📖 The STL1–STL3 error are all “Alarm latch” mode (in STL1–STL3 mode, the Pr. 06-44 function is no effective).

⚡ **02-13** Multi-function Output 1 (Relay1) Default:11

⚡ **02-14** Multi-function Output 2 (Relay2) Default:1

⚡ **02-15** Multi-function Output 3 (MO1) Default:0

⚡ **02-17** Multi-function Output 4 (MO2) Default:66

Settings 66: SO N.O. output  
68: SO N.C. output

---

Settings	Functions	Descriptions
66	SO Logic A output	Safety Output Normal Open
68	SO Logic B output	Safety Output Normal Close

📖 C2000 factory setting Pr. 02-17 (MO2) = 66 (N.O.) and Multi-function Output setting item adds 2 new function: 66 and 68.

Drive status	Safety Output status	
	N.O. (MO=66)	N.C. (MO=68)
Normal run	Open	Close
STO	Close	Open
STL1–STL3	Close	Open

⚡ **00-04** Content of Multi-function Display Default: 3

Settings 45: Hardware version

---

## 17-5 Operating Sequence Description

### 17-5-1 Normal operation status

As shown in Figure 3: When the STO1–SCM1 and STO2–SCM2=ON (no STO function is needed), the drive will execute “Operating” or “Output Stop” according to RUN/STOP command.

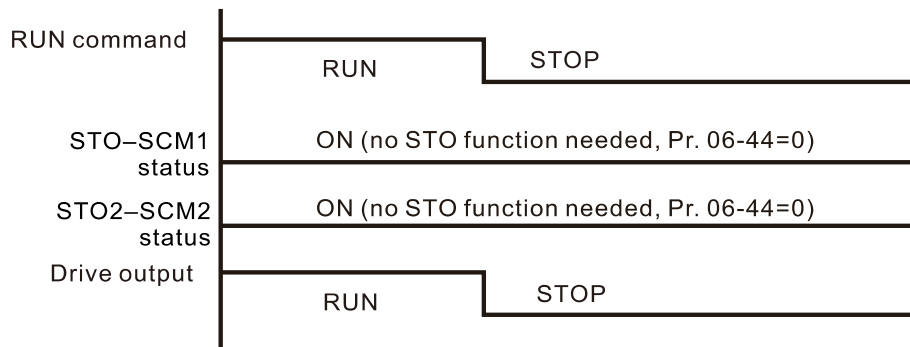

Figure 3

### 17-5-2-1 STO, Pr. 06-44=0, Pr. 02-35=0

As shown in Figure 4: When both of STO1–SCM1 and STO2–SCM2 channel has turned off during operating, the STO function enabling and the drive will stop output regardless of Run command is ON or OFF status.

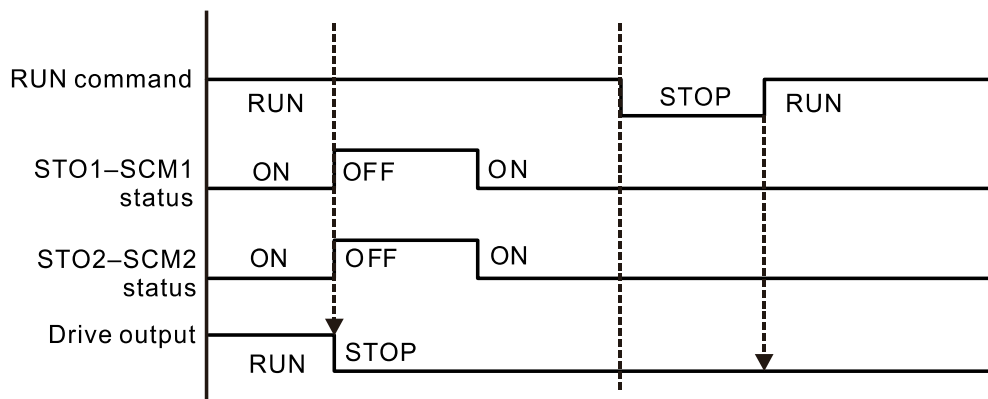

Figure 4

### 17-5-2-2 STO, Pr. 06-44=0, Pr. 02-35=1

As shown in Figure 5: As same as the figure 4. Because the Pr. 02-35=1, after the Reset command, if the operating command still exists, then the drive will immediately execute the run command again.

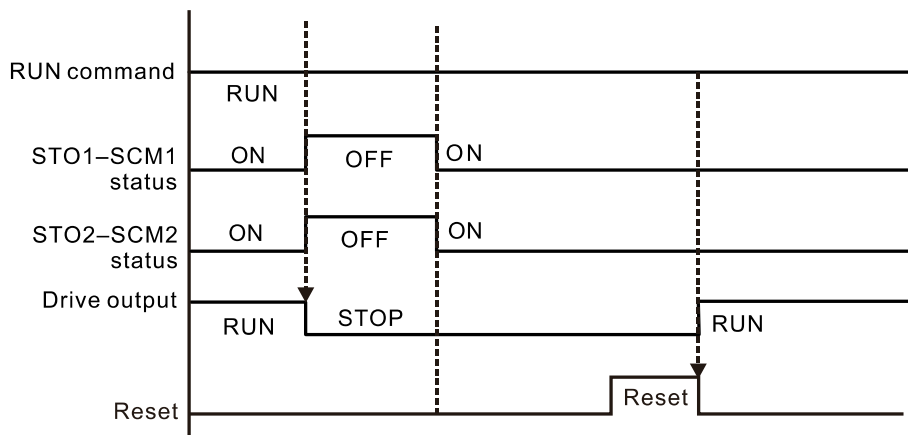

Figure 5

17-5-3 STO, Pr. 06-44=1

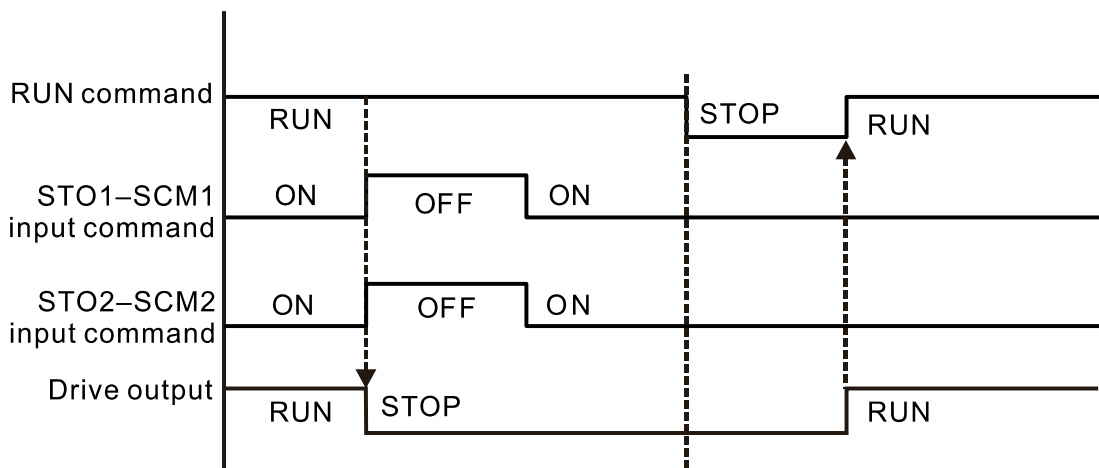

Figure 6

17-5-4 STL1

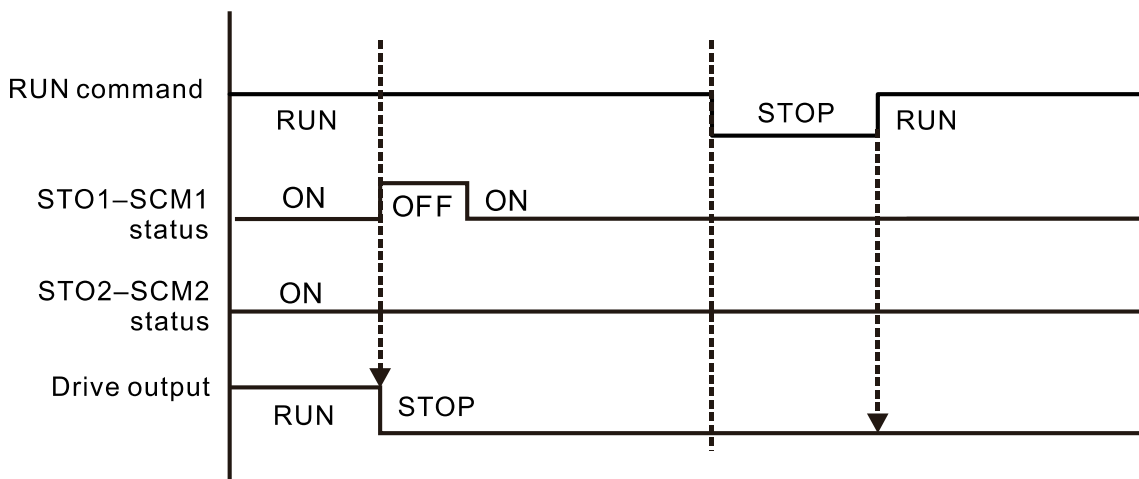

Figure 7

17-5-4 STL2

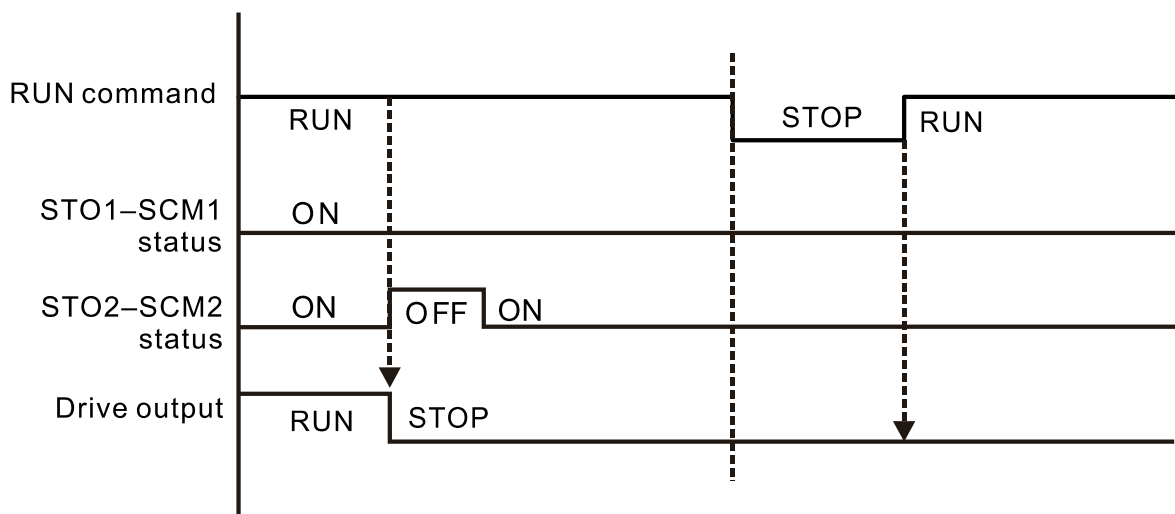

Figure 8



### 17-6 New Error Code for STO Function

- 06-17** Present Fault Record
- 06-18** Second Most Recent Fault Record
- 06-19** Third Most Recent Fault Record
- 06-20** Fourth Most Recent Fault Record
- 06-21** Fifth Most Recent Fault Record
- 06-22** Sixth Most Recent Fault Record

Settings 72: Channel 1 (STO1–SCM1) internal hardware error  
 76: STO (Safe Torque Off)  
 77: Channel 2 (STO2–SCM2) internal hardware error  
 78: Channel 1 and Channel 2 internal hardware error

Error code	Name	Description
76	STO	Safe Torque Off function active
72	STL1 (STO1–SCM1)	STO1–SCM1 internal hardware detect error
77	STL2 (STO2–SCM2)	STO2–SCM2 internal hardware detect error
78	STL3	STO1–SCM1 and STO2–SCM2 internal hardware detect error

The Old/New control board and Old/New I/O card:

C2000	v1.12 firmware	v1.20 firmware
v1.12 control board + old I/O card (no STO function)	OK	OK
v1.12 control board + new I/O card (with STO function)	Error	Error
v1.20 control board + old I/O card (no STO function)	Error	Error
v1.20 control board + new I/O card (with STO function)	Error	OK

# Appendix A. Revision History

New information	
Description	Related part
Combine the content of C2000 690V models to this manual.	Whole manual
Service link label introduction.	Chapter 1
Carton version unpacking steps of frame D models.	Chapter 3
The descriptions of short-circuit rated current (SCCR), built-in DC reactor model list, requirements on insulation level of Curve B motor, capacitor filter, dimension of flange mounting for frame D models, dimension and model names of magnetic ring, and description of power terminal kit.	Chapter 7
The descriptions of new extension cards, EMC-A22A (I/O relay), CMC-EC01 (Communication, EtherCAT), and CMC-PN01 (Communication, PROFINET). Delta standard fieldbus cable list.	Chapter 8
Efficiency curve, and derating curve of voltage / current.	Chapter 9
A note to describe how to use VFDSOFT when OS is Win10, and a process of Start Wizard.	Chapter 10
Add descriptions of the following parameters: <ul style="list-style-type: none"> <li>● Parameter group 01: 01-49</li> <li>● Parameter group 02: 02-71, 02-74, 02-75</li> <li>● Parameter group 04: 04-70–04-99</li> <li>● Parameter group 06: 06-51, 06-62, 06-86</li> <li>● Parameter group 07: 07-38, 07-62, 07-63</li> <li>● Parameter group 08: 08-26–08-28</li> <li>● Parameter group 10: 10-46</li> <li>● Parameter group 11: 11-46</li> <li>● Parameter group 13</li> <li>● Parameter group 14</li> </ul>	Chapter 11, Section 12-1
The descriptions of the adjustment and application for AC drive	Section 12-2
New functions of special relay (special M): M1090, M1091, M1092, M1100, M1101, M1168, M1260, M1262, M1270, M1271; new functions of special register (special D): D1200–D1207, D1209, D1215, D1220–D1227, D1229, D1235.	Chapter 16
New chapter to describe safety torque off function.	Chapter 17

Updated information	
Description	Related part
Nameplate information, and the description of RFI jumper.	Chapter 1
The descriptions of using the lifting hook and the figure.	Chapter 3
The wiring diagrams of all frame sizes, and the wiring of SINK (NPN) / SOURCE (PNP) mode.	Chapter 4
The wiring diagrams of main circuit terminals for all frame sizes, the descriptions of the main circuit terminals.	Chapter 5
The specifications of the control terminals and the wiring precautions.	Chapter 6
EMC filter model list, the specifications and the assembly of DC reactor, the model list and the descriptions of zero-phase reactor, the torque value, the figures, applicable models and assembly/disassembly of fan.	Chapter 7
The figures of extension cards, the figures to assembly / disassembly, the figure to illustrate the position of the terminating resistor and the extension cards.	Chapter 8
The cable length of PG card, the description of EMC-BPS01, and delete the description of CANopen cable and breakout box.	Chapter 8
The general specifications, the descriptions of environmental characteristics.	Chapter 9
Describe the functions which are listed on the MENU. Delete information of KPC-CE01.	Chapter 10
<p>Update descriptions of the following parameters:</p> <ul style="list-style-type: none"> <li>● Parameter group 00: 00-00, 00-04, 00-06, 00-11, 00-13, 00-17, 00-20, 00-24, 00-25, 00-40</li> <li>● Parameter group 01: 01-02–01-08, 01-11, 01-12–01-23, 01-24–01-27, 01-36–01-42, 01-43</li> <li>● Parameter group 02: 02-00, 02-01–02-08, 02-13, 02-14, 02-26–02-31, 02-34, 02-38–02-41, 02-42–02-46, 02-49, 02-50–02-53, 02-58, 02-70</li> <li>● Parameter group 03: 03-00, 03-02, 03-03–03-05, 03-09, 03-10, 03-19, 03-20, 03-23, 03-30, 03-51–03-74</li> <li>● Parameter group 05: 05-00–05-09, 05-13–05-15, 05-17–05-21, 05-28–05-30, 05-34, 05-35, 05-38, 05-43. Delete 05-26, 05-27</li> <li>● Parameter group 06: 06-02–06-04, 06-14, 06-16–06-22, 06-28, 06-29, 06-30, 06-39, 06-46, 06-52, 06-55</li> <li>● Parameter group 07: 07-00, 07-07, 07-08, 07-12–07-14, 07-19, 07-23</li> <li>● Parameter group 08: 08-00–08-02, 08-16, 08-20, 08-23</li> <li>● Parameter group 09: 09-04, 09-11–09-26, 09-31, 09-33, 09-39, 09-40, 09-60, 09-75, 09-84, 09-88, 09-89</li> <li>● Parameter group 10: 10-02, 10-16, 10-19, 10-24, 10-27, 10-30, 10-32, 10-34, 10-35–10-37, 10-41, 10-49, 10-51, 10-52. Delete 10-22</li> <li>● Parameter group 11: 11-00, 11-01, 11-11, 11-12, 11-17–11-20, 11-31, 11-32, 11-39, 11-40</li> </ul>	Chapter 11, Section 12-1

Updated information	
Description	Related part
The descriptions of the adjustment and application for AC drive.	Section 12-2
The descriptions of the warning codes	Chpater 13
The descriptions of the fault codes	Chpater 14
The descriptions of the bit setting for 2060H, 2020H. And the descriptions of speed mode, torque mode, PDO type no. 0.	Chpater 15
The function description of D1051, D1052, and D1111, D1112.	Chpater 16
The installation of WPLSoft	Chpater 16