

INVERTER

F510



INSTRUCTION MANUAL

230V Class 3~

Open Chassis / NEMA 1

3.7 - 132 kW

5 - 150 HP

460V Class 3~

Open Chassis / NEMA 1

3.7 - 185 kW

5 - 250 HP

- Read all operating instructions before installing, connecting (wiring), operating, servicing, or inspecting the inverter.
- Ensure that this manual is made available to the end user of the inverter.
- Store this manual in a safe, convenient location.
- The manual is subject to change without prior notice.

Table of Contents

| | |
|--|------------|
| Preface | 0-1 |
| 1 Safety Precautions | 1-1 |
| 1.1 Before Supplying Power to the Inverter | 1-1 |
| 1.2 Wiring | 1-2 |
| 1.3 Before Operation..... | 1-3 |
| 1.4 Parameters Setting | 1-3 |
| 1.5 Operation..... | 1-4 |
| 1.6 Maintenance, Inspection and Replacement | 1-5 |
| 1.7 Disposal of the Inverter | 1-5 |
| 2 Model Description | 2-1 |
| 2.1 Nameplate Data | 2-1 |
| 2.2 Inverter Models – Motor Power Rating..... | 2-2 |
| 3 Environment and Installation | 3-1 |
| 3.1 Environment..... | 3-1 |
| 3.2 Installation | 3-2 |
| 3.3 External View..... | 3-3 |
| 3.4 Warning Labels..... | 3-5 |
| 3.5 Removing the Front Cover and Keypad..... | 3-6 |
| 3.5.1 Standard type (IP00/IP20)..... | 3-7 |
| 3.6 Wire Gauges and Tightening Torque..... | 3-11 |
| 3.7 Wiring Peripheral Power Devices | 3-12 |
| 3.8 General Wiring Diagram..... | 3-14 |
| 3.9 User Terminals | 3-15 |
| 3.10 Power Terminals..... | 3-18 |
| 3.11 Input / Output Section Block Diagram | 3-20 |
| 3.11.1 Cooling Fan Supply Voltage Selection (460V class) | 3-23 |
| 3.12 Inverter Wiring | 3-24 |
| 3.13 Input Power and Motor Cable Length | 3-25 |
| 3.14 Cable Length vs, Carrier Frequency | 3-25 |
| 3.15 Installing an AC Line Reactor | 3-25 |
| 3.16 Power Input Wire Size, NFB and MCB Part Numbers | 3-26 |
| 3.17 Control Circuit Wiring | 3-28 |
| 3.18 Inverter Specifications | 3-30 |
| 3.19 General Specifications | 3-32 |
| 3.20 Inverter Derating Based on Carrier Frequency..... | 3-34 |
| 3.21 Inverter Derating Based on Temperature..... | 3-36 |
| 3.22 Inverter Dimensions | 3-37 |

| | |
|---|-------------|
| 4. Keypad and Programming Functions | 4-1 |
| 4.1 LCD Keypad | 4-1 |
| 4.1.1 Keypad Display and Keys | 4-1 |
| 4.1.2 Keypad Menu Structure | 4-3 |
| 4.2 Parameters | 4-8 |
| 4.3 Description of Parameters | 4-49 |
| | |
| 5. Check Motor Rotation and Direction | 5-1 |
| | |
| 6. Speed Reference Command Configuration | 6-1 |
| 6.1 Reference from the Keypad | 6-1 |
| 6.2 Reference from an Analog Signal (0-10V / 4-20mA) / Speed Pot | 6-2 |
| 6.3 Reference from Serial Communication RS485 | 6-4 |
| 6.4 Reference from two Analog Inputs | 6-6 |
| 6.5 Change Frequency Unit from Hz to rpm | 6-6 |
| | |
| 7. Operation Method Configuration (Run / Stop) | 7-1 |
| 7.1 Run / Stop from the Keypad | 7-1 |
| 7.2 Run / Stop from External Switch / Contact or Pushbutton | 7-2 |
| 7.3 Run / Stop from Serial Communication RS485 | 7-4 |
| | |
| 8. Motor and Application Specific Settings | 8-1 |
| 8.1 Set Motor Nameplate Data | 8-1 |
| 8.2 Acceleration and Deceleration Time | 8-2 |
| 8.3 Automatic Energy Savings Functions | 8-3 |
| 8.4 Emergency Stop | 8-5 |
| 8.5 Direct / Unattended Startup | 8-6 |
| 8.6 Analog Output Setup | 8-7 |
| | |
| 9. Using PID Control for Constant Flow / Pressure Applications | 9-1 |
| 9.1 What is PID Control | 9-1 |
| 9.2 Connect Transducer Feedback Signal | 9-3 |
| 9.3 Engineering Units | 9-4 |
| 9.4 Sleep / Wakeup Function | 9-5 |
| | |
| 10 Troubleshooting and Fault Diagnostics | 10-1 |
| 10.1 General | 10-1 |
| 10.2 Fault Detection Function | 10-1 |
| 10.3 Warning / Self-diagnosis Detection Function | 10-6 |
| 10.4 Auto-tuning Error | 10-13 |
| 10.5 PM Motor Auto-tuning Error | 10-14 |

| | |
|--|-------------|
| 11 Inverter Peripheral Devices and Option | 11-1 |
| 11.1 Braking Resistors and Braking Units | 11-1 |
| 11.2 AC Line Reactors..... | 11-3 |
| 11.2.1 230V Class AC Reactor Dimensions..... | 11-4 |
| 11.2.2 460V Class AC Reactor Dimensions..... | 11-5 |
| 11.3 Input Noise Filters | 11-6 |
| 11.4 Input Current and Fuse Specifications | 11-8 |
| 11.5 Other options | 11-9 |
| 11.6 Communication options | 11-13 |
| | |
| Appendix A: Single and Multi-Pump Wiring | A1 |
| Appendix B: UL Instructions | B1 |

Preface

The F510 product is an inverter designed to control a three-phase induction motor. Please read this manual carefully to ensure correct operation and safety aspects to become familiar with the inverter functions.



The F510 inverter is an electrical / electronic product and must be installed and handled by qualified service personnel.



Improper handling may result in incorrect operation, shorter life cycle, or failure of this product as well as the motor.

All F510 documentation is subject to change without notice. Be sure to obtain the latest editions for use or visit our website at www.tecowestinghouse.com , for documentation in Spanish visit www.tecowestinghouse.com.mx

Read this Instruction Manual thoroughly before proceeding with installation, connections (wiring), operation, or maintenance and inspection.

Ensure you have thorough knowledge of the inverter and familiarize yourself with all safety information and precautions before proceeding to operate the inverter. Read the this Instruction Manual for detailed description on parameters.

Please pay close attention to the safety precautions indicated by the warning  and caution  symbol.

| | |
|--|--|
|  Warning | Failure to ignore the information indicated by the warning symbol may result in death or serious injury. |
|  Caution | Failure to ignore the information indicated by the caution symbol may result in minor or moderate injury and/or substantial property damage. |

1. Safety Precautions

1.1 Before supplying Power to the Inverter



Warning

The main circuit must be correctly wired. For single phase supply use input terminals (R/L1, T/L3) and for three phase supply use input terminals (R/L1, S/L2, T/L3). Terminals U/T1, V/T2, W/T3 must only be used to connect the motor. Connecting the input supply to any of the U/T1, V/T2 or W/T3 terminals will cause damage to the inverter.



Caution

- To avoid the front cover from disengaging or other physical damage, do not carry the inverter by its cover. Support the unit by its heat sink when transporting. Improper handling can damage the inverter or injure personnel, and should be avoided.
- To avoid the risk of fire, do not install the inverter on or near flammable objects. Install on nonflammable objects such as metal surfaces.
- If several inverters are placed inside the same control enclosure, provide adequate ventilation to maintain the temperature below 40°C/104°F (50°C/122°F without a dust cover) to avoid overheating or fire.
- When removing or installing the digital operator, turn off the power first, and then follow the instructions in this manual to avoid operator error or loss of display caused by faulty connections.



Warning

This product is sold subject to IEC 61800-3. In a domestic environment this product may cause radio interference in which case the user may need to apply corrective measures.

1.2 Wiring



Warning

- Always turn OFF the power supply before attempting inverter installation and wiring of the user terminals.
- Wiring must be performed by a qualified personnel / certified electrician.
- Make sure the inverter is properly grounded. (230V Class: Grounding impedance shall be less than 100Ω. 460V Class: Grounding impedance shall be less than 10Ω.)
- Please check and test emergency stop circuits after wiring. (Installer is responsible for the correct wiring.)
- Never touch any of the input or output power lines directly or allow any input or output power lines to come in contact with the inverter case.
- Do not perform a dielectric voltage withstand test (megger) on the inverter this will result in inverter damage to the semiconductor components.



Caution

- The line voltage applied must comply with the inverter's specified input voltage. (See product nameplate section 2.1)
- Connect braking resistor and braking unit to the designated terminals. (See section 3.10)
- Do not connect a braking resistor directly to the DC terminals P(+) and N(-), otherwise fire may result.
- Use wire gauge recommendations and torque specifications. (See Wire Gauge and Torque Specification section 3.6)
- Never connect input power to the inverter output terminals U/T1, V/T2, W/T3.
- Do not connect a contactor or switch in series with the inverter and the motor.
- Do not connect a power factor correction capacitor or surge suppressor to the inverter output.
- Ensure the interference generated by the inverter and motor does not affect peripheral devices.

1.3 Before Operation



Warning

- Make sure the inverter capacity matches the parameters 13-00.
- Reduce the carrier frequency (parameter 11-01) if the cable from the inverter to the motor is greater than 80 ft (25m), refer to table 3.14.1. A high-frequency current can be generated by stray capacitance between the cables and result in an overcurrent trip of the inverter, an increase in leakage current, or an inaccurate current readout.
- Be sure to install all covers before turning on power. Do not remove any of the covers while power to the inverter is on, otherwise electric shock may occur.
- Do not operate switches with wet hands, otherwise electric shock may result.
- Do not touch inverter terminals when energized even if inverter has stopped, otherwise electric shock may result.

1.4 Parameter Setting



Caution

- Do not connect a load to the motor while performing a rotational auto-tune.
- Make sure the motor can freely run and there is sufficient space around the motor when performing a rotational auto-tune.

1.5 Operation



Warning

- Be sure to install all covers before turning on power. Do not remove any of the covers while power to the inverter is on, otherwise electric shock may occur.
- Do not connect or disconnect the motor during operation. This will cause the inverter to trip and may cause damage to the inverter.
- Operations may start suddenly if an alarm or fault is reset with a run command active. Confirm that no run command is active upon resetting the alarm or fault, otherwise accidents may occur.
- Do not operate switches with wet hands, otherwise electric shock may result.
- All F510 inverters have an independent external hardware emergency switch, which immediately shuts down the inverter output in the case of danger.
- If automatic restart after power recovery (parameter 07-00) is enabled, the inverter will start automatically after power is restored.
- Make sure it is safe to operate the inverter and motor before performing a rotational auto-tune.
- Do not touch inverter terminals when energized even if inverter has stopped, otherwise electric shock may result.
- Do not check signals on circuit boards while the inverter is running.
- After the power is turned off, the cooling fan may continue to run for some time.



Caution

- Do not touch heat-generating components such as heat sinks and braking resistors.
- Carefully check the performance of motor or machine before operating at high speed, otherwise Injury may result.
- Note the parameter settings related to the braking unit when applicable.
- Do not use the inverter braking function for mechanical holding, otherwise injury may result.
- Do not check signals on circuit boards while the inverter is running.

1.6 Maintenance, Inspection and Replacement



Warning

- Wait a minimum of five minutes after power has been turned OFF before starting an inspection. Also confirm that the charge light is OFF and that the DC bus voltage has dropped below 25Vdc.
- Never touch high voltage terminals in the inverter.
- Make sure power to the inverter is disconnected before disassembling the inverter.
- Only authorized personnel should perform maintenance, inspection, and replacement operations. (Remove any metal jewelry such as watches and rings and use insulated tools.)



Caution

- The Inverter can be used in an environment with a temperature range from 14° -104°F (-10-40°C) and relative humidity of 95% non-condensing.
- The inverter must be operated in a dust, gas, mist and moisture free environment.

1.7 Disposal of the Inverter



Caution

- Please dispose of this unit with care as an industrial waste and according to your any local regulations.
- The capacitors of inverter main circuit and printed circuit board are considered as hazardous waste and must not be burned.
- The Plastic enclosure and parts of the inverter such as the top cover board will release harmful gases if burned.

2. Model Description

2.1 Nameplate Data

It is essential to verify the F510 inverter nameplate and make sure that the F510 inverter has the correct rating so it can be applied with the proper sized AC motor.

Unpack the F510 inverter and check the following:

- (1) The F510 inverter and instruction manual (this document) are contained in the package.
- (2) The F510 inverter has not been damaged during transportation there should be no dents or parts missing.
- (3) The F510 inverter is the correct ratings as ordered. Check the type and specifications on the main nameplate.
- (4) Check that the input voltage range meets the input power requirements.
- (5) Ensure that the motor full load amp rating matches the output rating of the inverter.

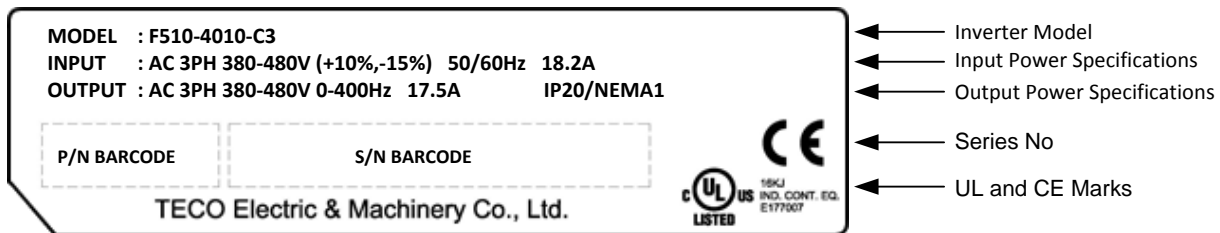

Model Identification

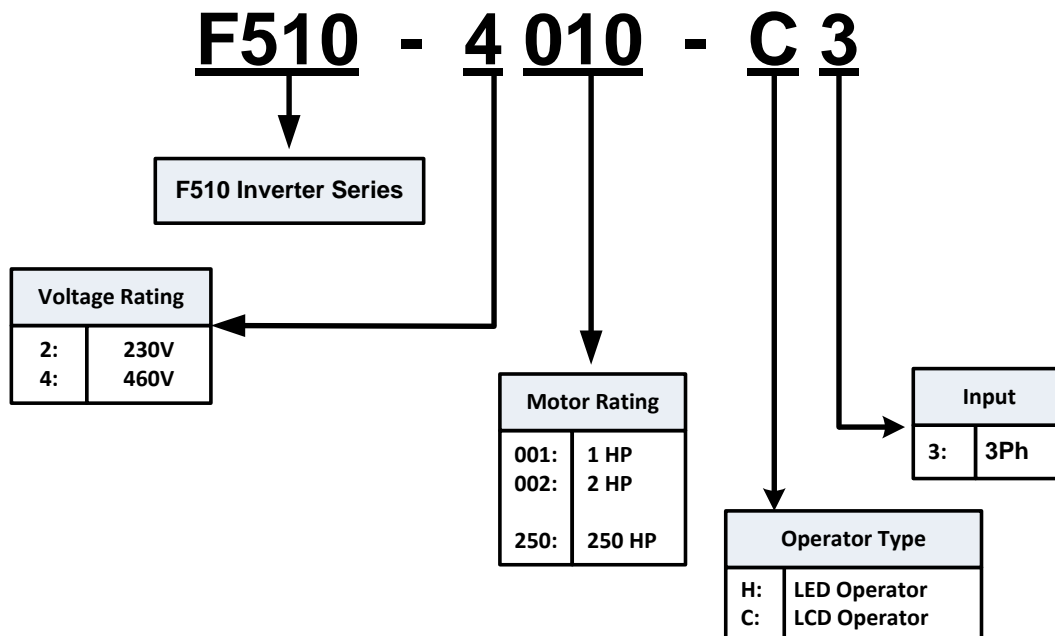

2.2 Inverter Models – Motor Power Rating (ND – Normal Duty / Variable Torque)

230V Class

| Voltage (Vac) & Frequency (Hz) | F510 Model | Motor Power (HP) | Applied Motor (kW) | Operator | |
|---|--------------|---------------------|-----------------------|----------|-----|
| | | | | LED | LCD |
| 3ph 200~240V +10%/-15% 50/60Hz | F510-2005-C3 | 5 | 3.7 | | ⊙ |
| | F510-2008-C3 | 7.5 | 5.5 | | ⊙ |
| | F510-2010-C3 | 10 | 7.5 | | ⊙ |
| | F510-2015-C3 | 15 | 11 | | ⊙ |
| | F510-2020-C3 | 20 | 15 | | ⊙ |
| | F510-2025-C3 | 25 | 18.5 | | ⊙ |
| | F510-2030-C3 | 30 | 22 | | ⊙ |
| | F510-2040-C3 | 40 | 30 | | ⊙ |
| | F510-2050-C3 | 50 | 37 | | ⊙ |
| | F510-2060-C3 | 60 | 45 | | ⊙ |
| | F510-2075-C3 | 75 | 55 | | ⊙ |
| | F510-2100-C3 | 100 | 75 | | ⊙ |
| | F510-2125-C3 | 125 | 94 | | ⊙ |
| | F510-2150-C3 | 150 | 112 | | ⊙ |
| | F510-2175-C3 | 175 | 130 | | ⊙ |

Shaded Section: Models currently under development

460V Class

| Voltage (Vac) / Frequency (Hz) | F510 Model | Motor Power (HP) | Applied Motor (kW) | Operator | |
|---|--------------|---------------------|-----------------------|----------|-----|
| | | | | LED | LCD |
| 3ph 380~480V +10%/-15% 50/60Hz | F510-4005-H3 | 5 | 3.7 | ⊙ | |
| | F510-4005-C3 | 5 | 3.7 | | ⊙ |
| | F510-4008-C3 | 7.5 | 5.5 | | ⊙ |
| | F510-4010-C3 | 10 | 7.5 | | ⊙ |
| | F510-4015-C3 | 15 | 11 | | ⊙ |
| | F510-4020-C3 | 20 | 15 | | ⊙ |
| | F510-4025-C3 | 25 | 18.5 | | ⊙ |
| | F510-4030-C3 | 30 | 22 | | ⊙ |
| | F510-4040-C3 | 40 | 30 | | ⊙ |
| | F510-4050-H3 | 50 | 37 | ⊙ | |
| | F510-4050-C3 | 50 | 37 | | ⊙ |
| | F510-4060-H3 | 60 | 45 | ⊙ | |
| | F510-4060-C3 | 60 | 45 | | ⊙ |
| | F510-4075-H3 | 75 | 55 | ⊙ | |
| | F510-4075-C3 | 75 | 55 | | ⊙ |
| | F510-4100-H3 | 100 | 75 | ⊙ | |
| | F510-4100-C3 | 100 | 75 | | ⊙ |
| | F510-4125-H3 | 125 | 94 | ⊙ | |
| | F510-4125-C3 | 125 | 94 | | ⊙ |
| | F510-4150-H3 | 150 | 112 | ⊙ | |
| | F510-4150-C3 | 150 | 112 | | ⊙ |
| | F510-4175-H3 | 175 | 130 | ⊙ | |
| | F510-4175-C3 | 175 | 130 | | ⊙ |
| | F510-4215-H3 | 215 | 160 | ⊙ | |
| F510-4215-C3 | 215 | 160 | | ⊙ | |
| F510-4250-H3 | 250 | 185 | ⊙ | | |
| F510-4250-C3 | 250 | 185 | | ⊙ | |

460V Class (Continued)

| Voltage (Vac) / Frequency (Hz) | F510 Model | Motor Power (HP) | Applied Motor (kW) | Operator | |
|---|--------------|---------------------|-----------------------|----------|-----|
| | | | | LED | LCD |
| 3ph 380~480V +10%/-15% 50/60Hz | F510-4300-H3 | 300 | 220 | ⊙ | |
| | F510-4300-C3 | 300 | 220 | | ⊙ |
| | F510-4375-H3 | 375 | 280 | ⊙ | |
| | F510-4375-C3 | 375 | 280 | | ⊙ |
| | F510-4425-H3 | 425 | 317 | ⊙ | |
| | F510-4425-C3 | 425 | 317 | | ⊙ |
| | F510-4535-H3 | 535 | 400 | ⊙ | |
| | F510-4535-C3 | 535 | 400 | | ⊙ |
| | F510-4670-H3 | 670 | 500 | ⊙ | |
| | F510-4670-C3 | 670 | 500 | | ⊙ |
| | F510-4800-H3 | 800 | 600 | ⊙ | |
| | F510-4800-C3 | 800 | 600 | | ⊙ |

Shaded Section: Models currently under development.

3. Environment and Installation

3.1 Environment

The environment will directly affect the proper operation and the life span of the inverter. To ensure that the inverter will give maximum service life, please comply with the following environmental conditions:

| | |
|------------------------------|--|
| Protection | |
| Protection Class | IP20 / NEMA 1 or IP00 |
| | NEMA 12 |
| Operating Temperature | Ambient Temperature: (-10°C to +40°C (14 to 104 °F) Without Cover: -10°C to +50°C (14 to 122 °F) If several inverters are placed in the same control panel, provide additional cooling to maintain ambient temperatures below 40°C |
| Storage Temperature | -20°C - +70°C (-4 to 158 °F) |
| Humidity: | 95% non-condensing Relative humidity 5% to 95%, free of moisture. (Follow IEC60068-2-78 standard) |
| Altitude: | < 3,281 ft. (1000m) |
| Installation Site: | Avoid exposure to rain or moisture. |
| | Avoid direct sunlight. |
| | Avoid oil mist and salinity. |
| | Avoid corrosive liquid and gas. |
| | Avoid dust, lint fibers, and metal filings. |
| | Keep away from radioactive and flammable materials. |
| | Avoid electromagnetic interference (soldering machines, power machines). |
| | Avoid vibration (stamping, punching machines etc.). Add a vibration-proof pad if vibration cannot be avoided. |
| Shock | Maximum acceleration: 1.2G (12m/s ²), from 49.84 to 150 Hz Displacement amplitude : 0.3mm (peak value), from 10 to 49.84 Hz (Follow IEC60068-2-6 standard) |

3.2 Installation

When installing the inverter, ensure that inverter is installed in upright position (vertical direction) and there is adequate space around the unit to allow normal heat dissipation as per the following Fig. 3.2.1

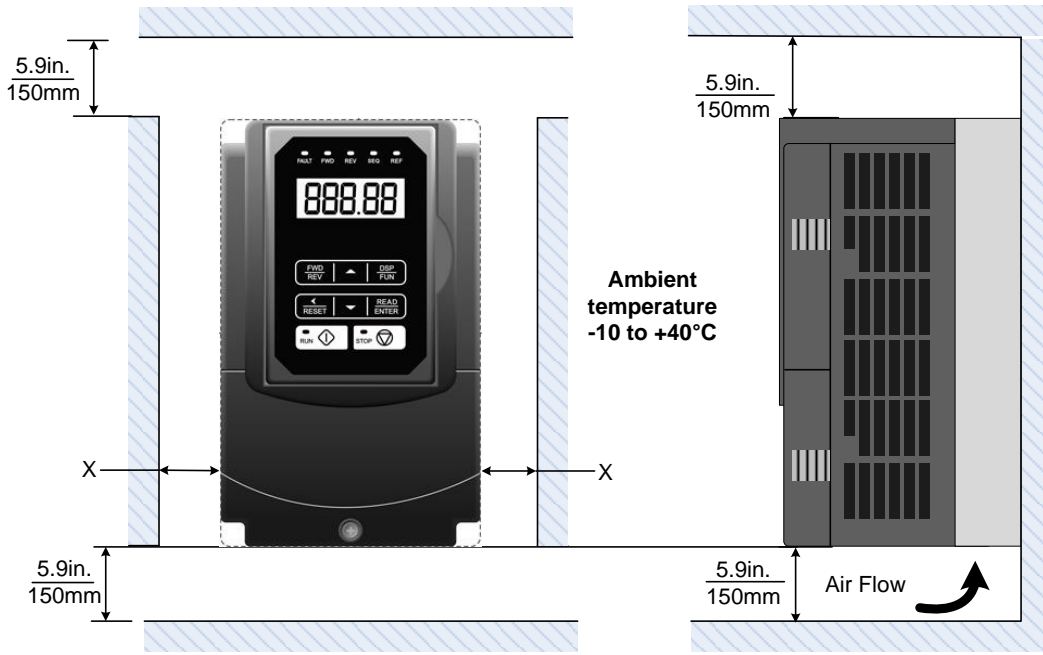

Fig 3.2.1: F510 Installation space

X = 1.18" (30mm) for inverter ratings up to 25HP

X = 1.96" (50mm) for inverter ratings 30HP or higher

Important Note: The inverter heatsink temperature can reach up to 194°F / 90°C during operation; Use insulation material rated for this temperature.

3.3 External View

(a) 230V 5-7.5HP/ 460V 5-10HP

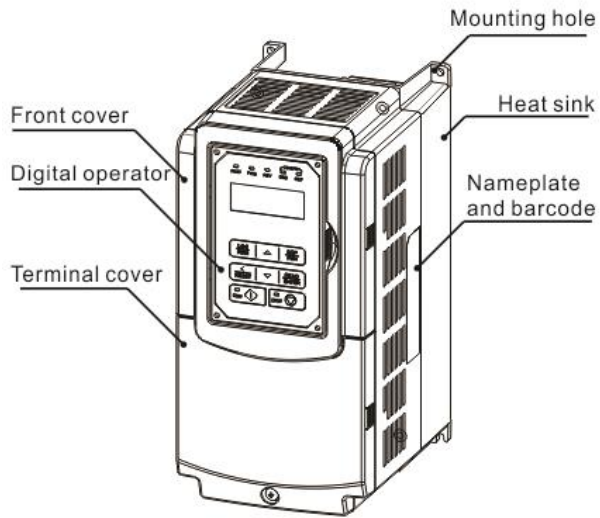

(Wall-mounted type, IEC IP00)

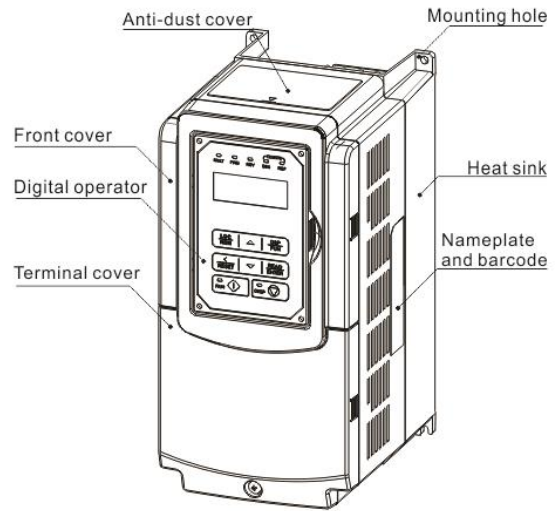

(Wall-mounted type, IEC IP20, NEMA1)

(b) 230V 10-30HP/ 460V 15-40HP

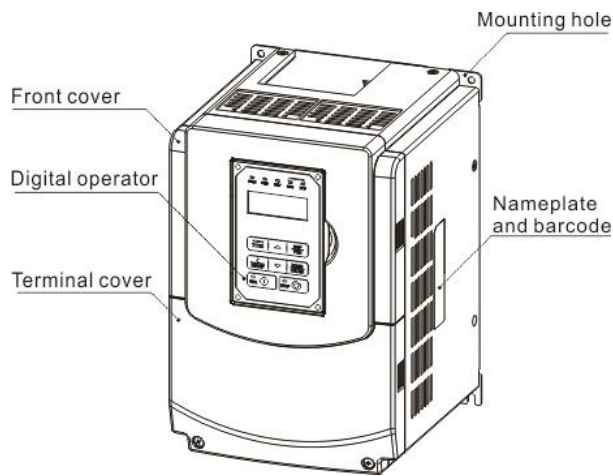

(Wall-mounted type, IEC IP00)

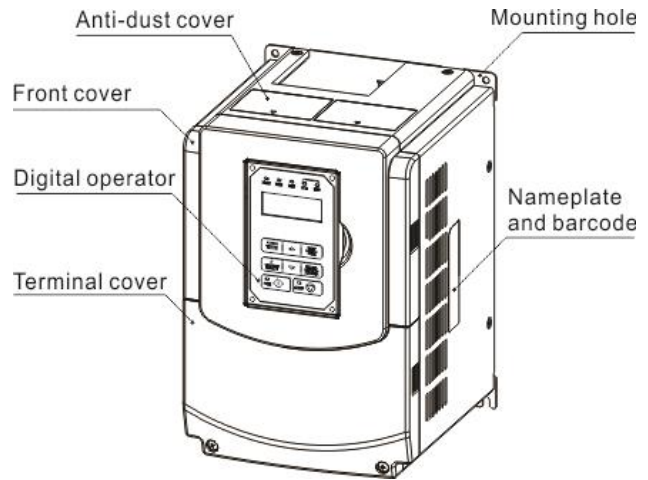

(Wall-mounted type, IEC IP20, NEMA1)

(c) 230V 40-50HP/ 460V 50-75HP

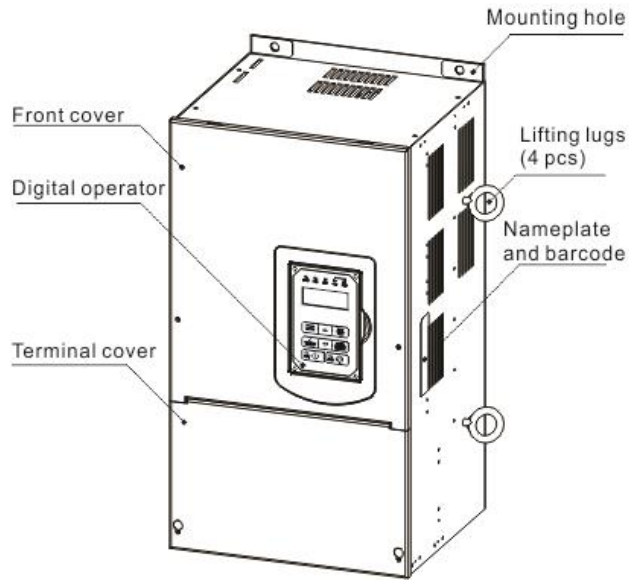

(Wall-mounted type, IEC IP20, NEMA1)

(d) 230V 60-125HP/ 460V 100-250HP

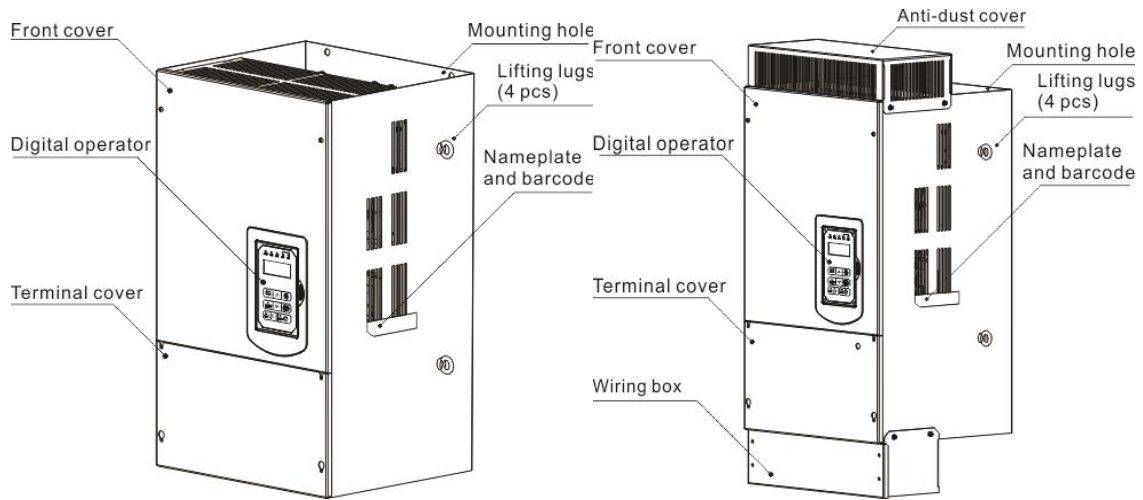

(Wall-mounted type, IEC IP00)

(Wall-mounted type, IEC IP20, NEMA1)

3.4 Warning Labels

Important: Warning information located on the front cover must be read upon installation of the inverter.



(a) 230V: 5 ~ 7.5HP / 460V: 5 ~ 10HP (IP20)



(b) 230V: 10 ~15HP / 460V: 15 ~ 20HP

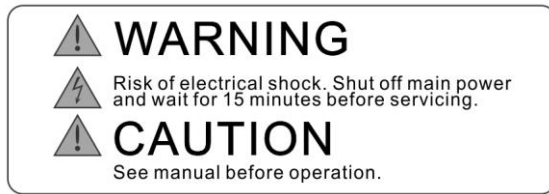

(c) 230V: 20 ~ 125HP / 460V: 20 ~ 250HP



(d) 460V: 5 ~ 100HP / 460V: 5 ~ 100HP

3.5 Removing the Front Cover and Keypad

IP00 / IP20



Caution

- Before making any wiring connections to the inverter the front cover needs to be removed.
- It is not required to remove the digital operator before making any wiring connections.
- Models 230V, 5 – 30 HP and 460V, 5 – 40 HP have a plastic cover. Loosen the screws and remove the cover to gain access to the terminals and make wiring connections. Place the plastic cover back and fasten screws when wiring connections have been made.
- Models 230V, 40 -125 HP and 460V, 50 – 250 HP have a metal cover. Loosen the screws and remove the cover to gain access to the terminals and make wiring connections. Place the metal cover back and fasten screws when wiring connections have been made.

3.5.1 Standard Type

(a) 230V: 5 ~ 7.5 HP / 460V: 5 ~ 10 HP

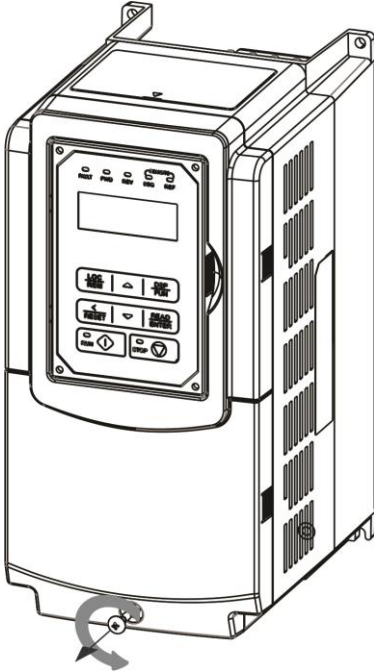

Step 1: Unscrew cover

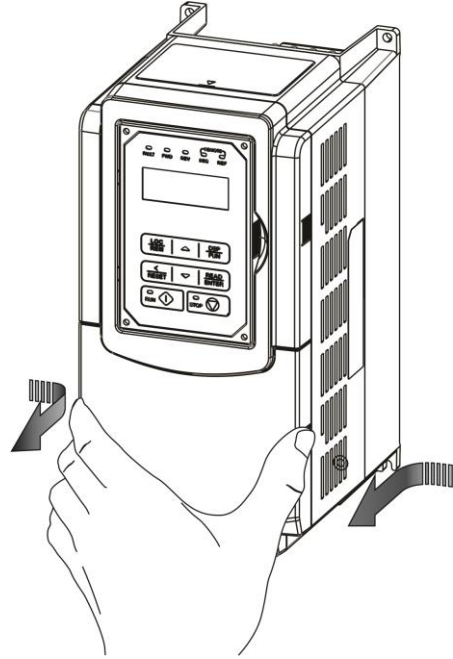

Step 2: Remove cover

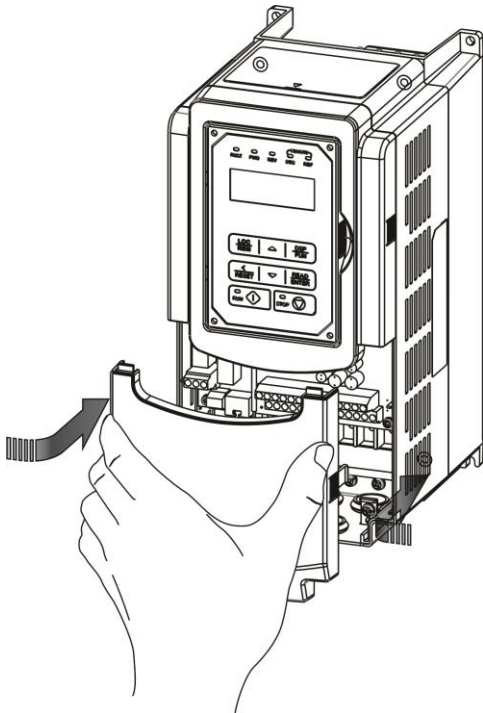

Step 3: Make wire connections and reinstall cover

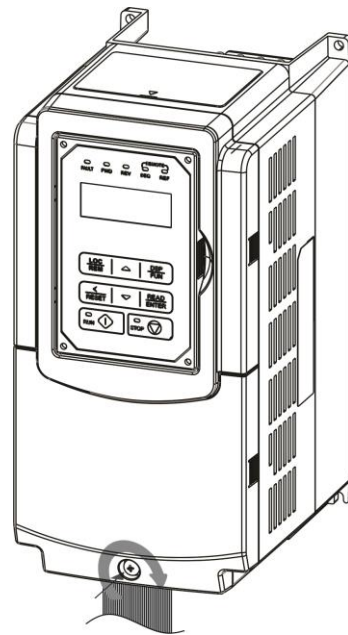

Step 4: Fasten screw

(b) 230V: 5 ~ 7.5 HP / 460V: 5 ~ 10 HP

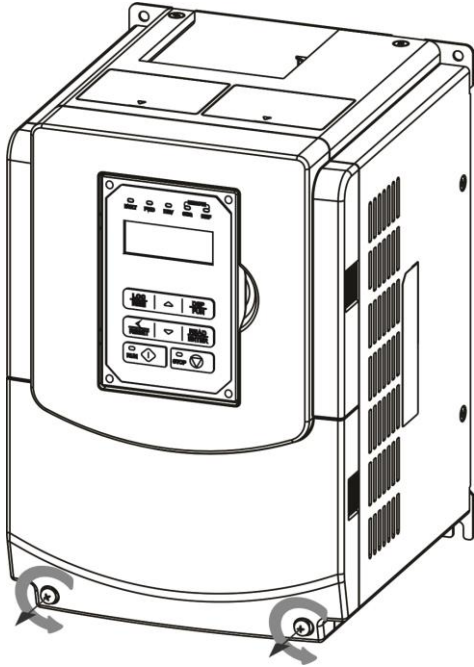

Step 1: Unscrew cover

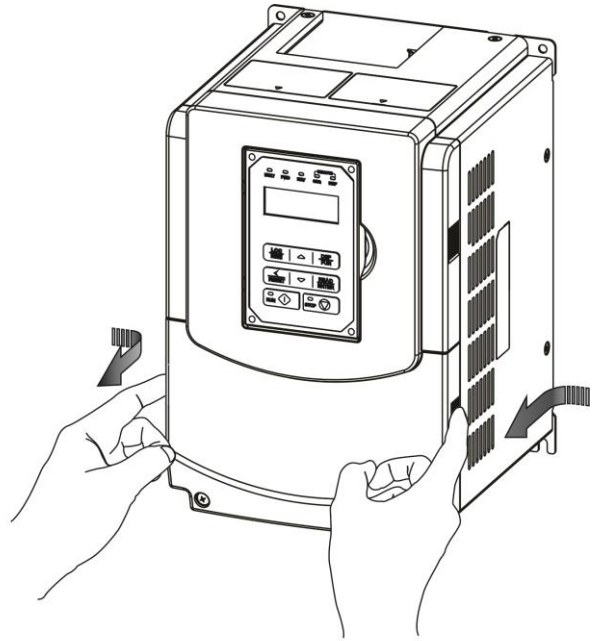

Step 2: Remove cover

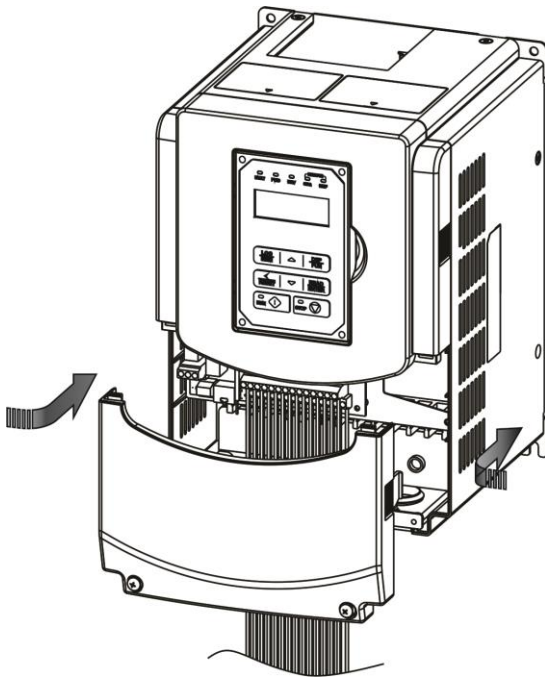

Step 3: Make wire connections and reinstall cover

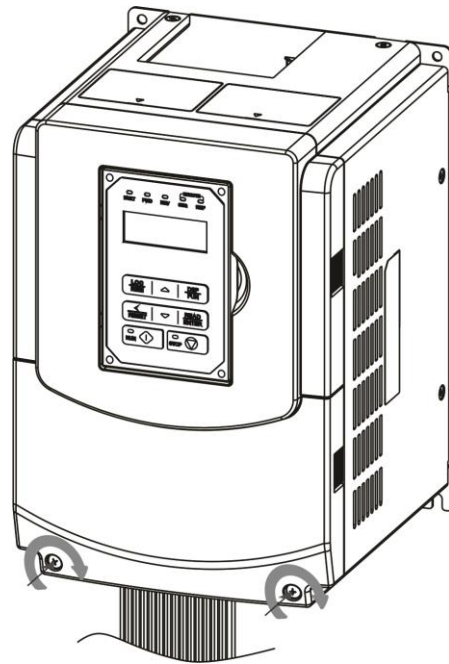

Step 4: Fasten screw

(c) 230V: 40 ~ 50 HP / 460V: 50 ~ 75 HP

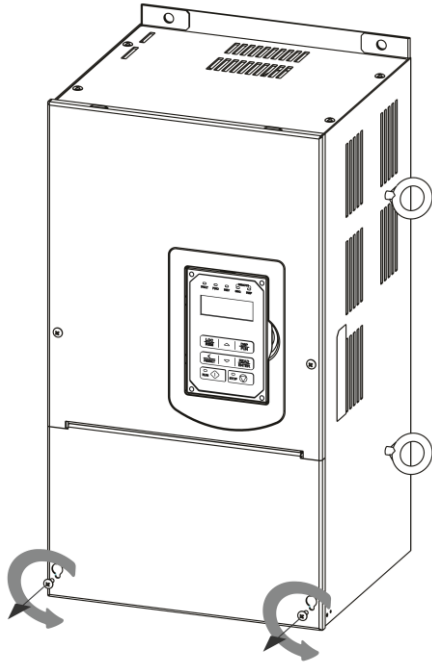

Step 1: Unfasten screw on cover

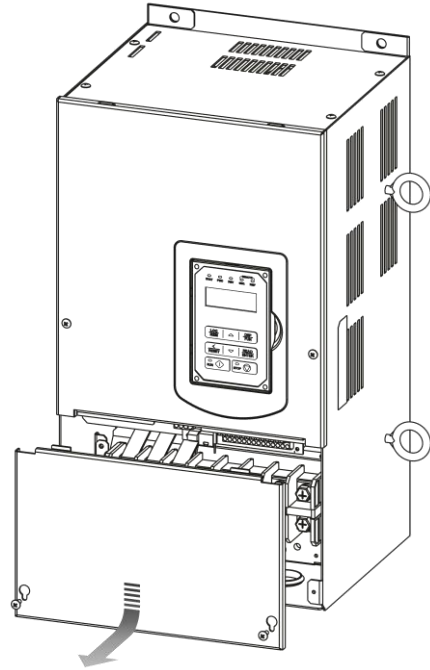

Step 2: Remove cover

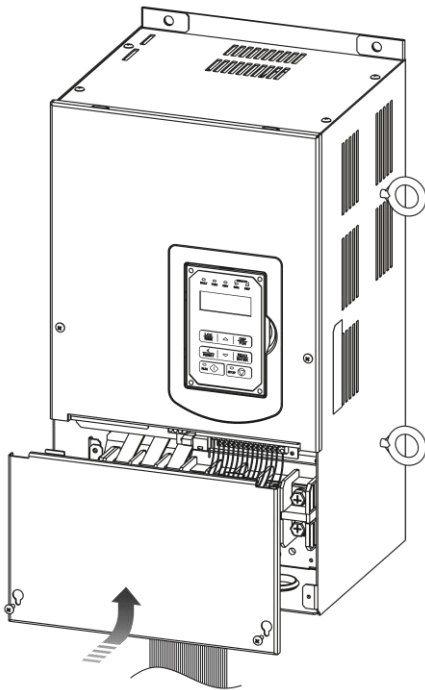

Step 3: Make wire connections and reinstall cover

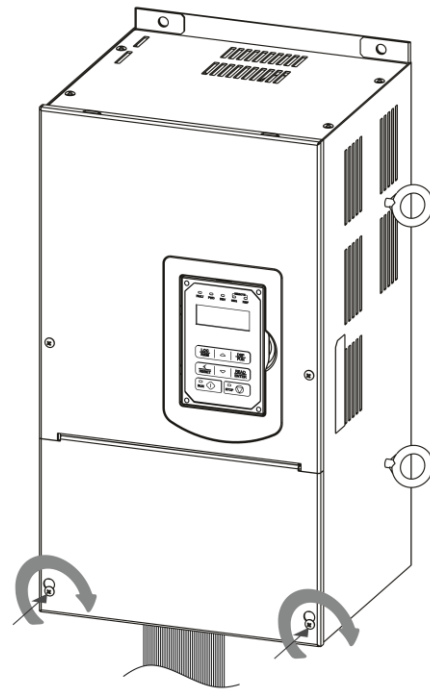

Step 4: Fasten screw

(d) 230V: 60 ~ 125 HP / 460V: 100 ~ 250 HP

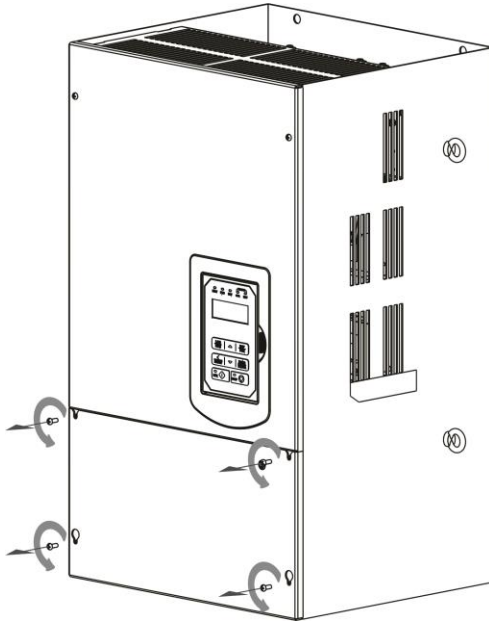

Step 1: Unfasten screw on cover

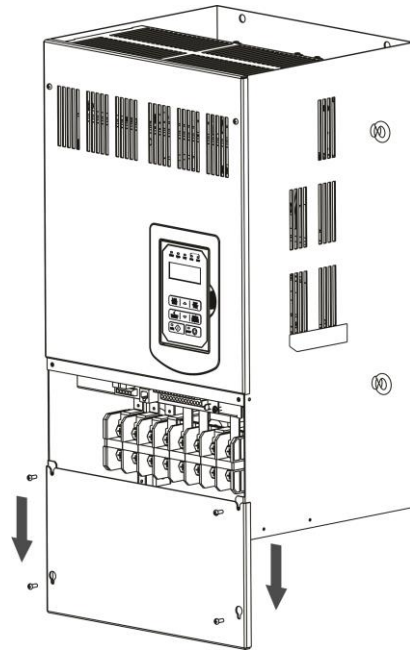

Step 2: Remove cover

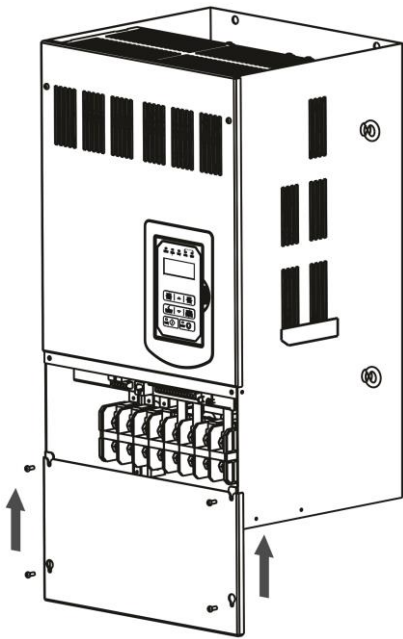

Step 3: Make wire connections and reinstall cover

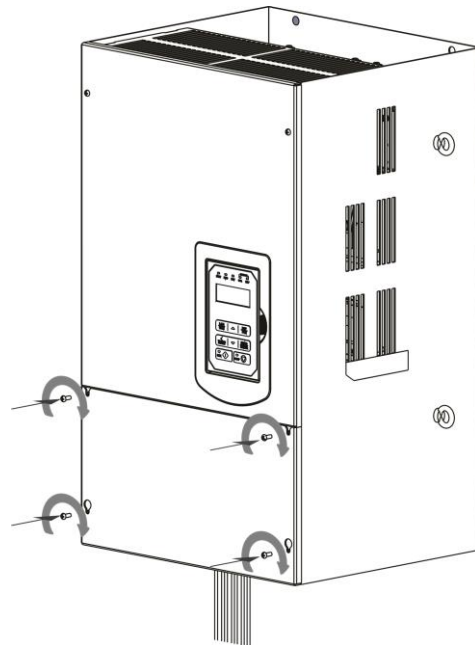

Step 4: Fasten screw

3.6 Wire Gauges and Tightening Torque

To comply with UL standards, use UL approved copper wires (rated 75° C) and round crimp terminals (UL Listed products) as shown in table below when connecting to the main circuit terminals. TECO recommends using crimp terminals manufactured by NICHIFU Terminal Industry Co., Ltd and the terminal crimping tool recommended by the manufacturer for crimping terminals and the insulating sleeve.

| Wire size mm ² (AWG) | Terminal screw size | Model of the round crimp terminal | Fastening torque in.lbs (kgf.cm) | Model of insulating sleeve | Model of crimp tool |
|------------------------------------|------------------------|---|-------------------------------------|----------------------------------|------------------------|
| 0.75 (18) | M3.5 | R1.25-3.5 | 8.2 to 10 (7.1 to 8.7) | TIC 1.25 | NH 1 |
| | M4 | R1.25-4 | 12.2 to 14 (10.4 to 12.1) | TIC 1.25 | NH 1 |
| 1.25 (16) | M3.5 | R1.25-3.5 | 8.2 to 10 (7.1 to 8.7) | TIC 1.25 | NH 1 |
| | M4 | R1.25-4 | 12.2 to 14 (10.4 to 12.1) | TIC 1.25 | NH 1 |
| 2 (14) | M3.5 | R2-3.5 | 8.2 to 10 (7.1 to 8.7) | TIC 2 | NH 1 / 9 |
| | M4 | R2-4 | 10.4 to 12.1 (12.2 to 14) | TIC 2 | NH 1 / 9 |
| | M5 | R2-5 | 17.7 to 20.8 (22.1 to 24) | TIC 2 | NH 1 / 9 |
| | M6 | R2-6 | 22.1 to 26.0 (25.5 to 30.0) | TIC 2 | NH 1 / 9 |
| 3.5/5.5 (12/10) | M4 | R5.5-4 | 10.4 to 12.1 (12.2 to 14) | TIC 5.5 | NH 1 / 9 |
| | M5 | R5.5-5 | 17.7 to 20.8 (20.4 to 24) | TIC 5.5 | NH 1 / 9 |
| | M6 | R5.5-6 | 22.1 to 26.0 (25.5 to 30.0) | TIC 5.5 | NH 1 / 9 |
| | M8 | R5.5-8 | 53.0 to 57.2 (61.2 to 66.0) | TIC 5.5 | NH 1 / 9 |
| 8 (8) | M4 | R8-4 | 10.4 to 12.1 (12.2 to 14) | TIC 8 | NOP 60 |
| | M5 | R8-5 | 17.7 to 20.8 (20.4 to 24) | TIC 8 | NOP 60 |
| | M6 | R8-6 | 22.1 to 26.0 (25.5 to 30.0) | TIC 8 | NOP 60 |
| | M8 | R8-8 | 53.0 to 57.2 (25.5 to 30.0) | TIC 8 | NOP 60 |
| 14 (6) | M4 | R14-4 | 10.4 to 12.1 (12.2 to 14) | TIC 14 | NH 1 / 9 |
| | M5 | R14-5 | 17.7 to 20.8 (20.4 to 24) | TIC 14 | NH 1 / 9 |
| | M6 | R14-6 | 22.1 to 26.0 (25.5 to 30.0) | TIC 14 | NH 1 / 9 |
| | M8 | R14-8 | 53.0 to 57.2 (61.2 to 66.0) | TIC 14 | NH 1 / 9 |
| 22 (4) | M6 | R22-6 | 22.1 to 26.0 (25.5 to 30.0) | TIC 22 | NOP 60/ 150H |
| | M8 | R22-8 | 53.0 to 57.2 (61.2 to 66.0) | TIC 22 | NOP 60/ 150H |
| 30/38 (3 /2) | M6 | R38-6 | 22.1 to 26.0 (25.5 to 30.0) | TIC 38 | NOP 60/ 150H |
| | M8 | R38-8 | 53.0 to 57.2 (61.2 to 66.0) | TIC 38 | NOP 60/ 150H |
| 50 / 60 (1/1/0) | M8 | R60-8 | 53.0 to 57.2 (61.2 to 66.0) | TIC 60 | NOP 60/ 150H |
| | M10 | R60-10 | 88.5 to 104 (102 to 120) | TIC 60 | NOP 150H |
| 70 (2/0) | M8 | R70-8 | 53.0 to 57.2 (61.2 to 66.0) | TIC 60 | NOP 150H |
| | M10 | R70-10 | 88.5 to 104 (102 to 120) | TIC 60 | NOP 150H |
| 80 (3/0) | M10 | R80-10 | 88.5 to 104 (102 to 120) | TIC 80 | NOP 150H |
| | M16 | R80-16 | 8.2 to 10 (7.1 to 8.7) | TIC 80 | NOP 150H |
| 100 (4/0) | M10 | R100-10 | 12.2 to 14 (10.4 to 12.1) | TIC 100 | NOP 150H |
| | M12 | R100-12 | 8.2 to 10 (7.1 to 8.7) | TIC 100 | NOP 150H |
| | M16 | R80-16 | 12.2 to 14 (10.4 to 12.1) | TIC 80 | NOP 150H |

3.7 Wiring Peripheral Power Devices



Caution

- After power is shut off to the inverter the capacitors will slowly discharge. Do NOT touch and of the inverter circuitry or replace any components until the “CHARGE” indicator is off.
- Do NOT wire or connect/disconnect internal connectors of the inverter when the inverter is powered up or when powered off and the “CHARGE” indicator is on.
- Do NOT connect inverter output U, V and W to the supply power. This will result in damage to the inverter.
- The inverter must be properly grounded. Use terminal E to connect earth ground and comply with local standards.
- Do NOT perform a dielectric voltage withstand test (Megger) on the inverter this will result in inverter damage to the semiconductor components.
- Do NOT touch any of the components on the inverter control board to prevent damage to the inverter by static electricity.



Caution

- Refer to the recommended wire size table for the appropriate wire to use. The voltage between the power supply and the input of the inverter may not exceed 2%.

$$\text{Phase-to-phase voltage drop (V)} = \sqrt{3} \times \text{resistance of wire } (\Omega/\text{km}) \times \text{length of line (m)} \times \text{current} \times 10^{-3}.$$

(km=3280 x feet) / (m=3.28 x feet)

- Reduce the carrier frequency (parameter 11-01) If the cable from the inverter to the motor is greater than 25m (82ft). A high-frequency current can be generated by stray capacitance between the cables and result in an overcurrent trip of the inverter, an increase in leakage current, or an inaccurate current readout.
- To protect peripheral equipment, install fast acting fuses on the input side of the inverter. Refer to section 11.4 for additional information.



Power supply:

- Make sure the correct voltage is applied to avoid damaging the inverter.



Molded-case circuit breaker (MCCB) or fused disconnect:

- A molded-case circuit breaker or fused disconnect must be installed between the AC source and the inverter that conforms to the rated voltage and current of the inverter to control the power and protect the inverter.



- Do not use the circuit breaker as the run/stop switch for the inverter.

Ground fault detector / breaker:

- Install a ground fault breaker to prevent problems caused by current leakage and to protect personnel. Select current range up to 200mA, and action time up to 0.1 second to prevent high frequency failure.



Magnetic contactor:

- Normal operations do not need a magnetic contactor. When performing functions such as external control and auto restart after power failure, or when using a brake controller, install a magnetic contactor.



- Do not use the magnetic contactor as the run/stop switch for the inverter.

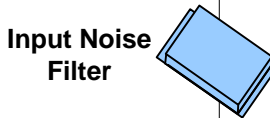

AC line reactor for power quality:

- When inverters are supplied by a high capacity power source (> 600KVA), an AC reactor can be connected to improve the power factor.

Install Fast Acting Fuse:

- To protect peripheral equipment, install fast acting fuses in accordance with the specifications in section 11 for peripheral devices.



Input Noise filter:

- A filter must be installed when there are inductive loads affecting the inverter. The inverter meets EN55011 Class A, category C3 when the TECO special filter is used. See section 11 for peripheral devices.

Ground

Inverter:

- Output terminals T1, T2, and T3 are connected to U, V, and W terminals of the motor. If the motor runs in reverse while the inverter is set to run forward, swap any two terminals connections for T1, T2, and T3.

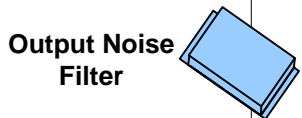

- To avoid damaging the inverter, do not connect the output terminals T1, T2, and T3 to AC input power.

- Connect the ground terminal properly. (230V series: Rg <100Ω; 460V series: Rg <10Ω.)

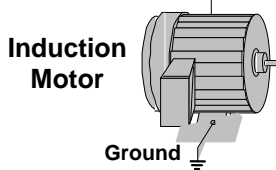

Output Noise filter:

- An output noise filter may reduce system interference and induced noise. See section 11 for peripheral devices.

Motor:

- If the inverter drives multiple motors the output rated current of the inverter must be greater than the total current of all the motors.

3.8 General Wiring Diagram

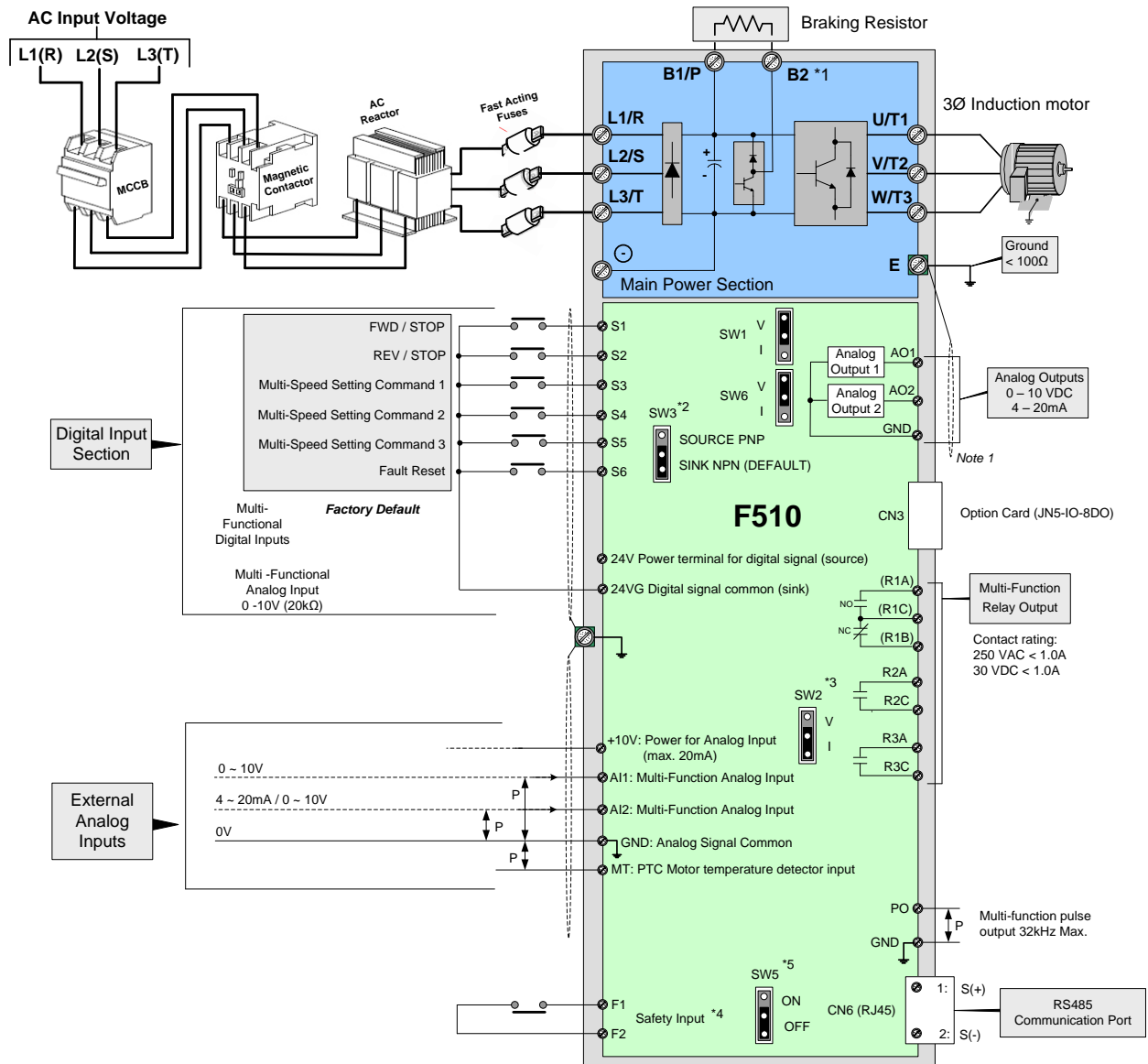

Notes:

- *1: Models IP20 230V 5 ~ 30HP, 460V 5 ~ 40HP have a built-in braking transistor. To use this braking transistor a braking resistor can be connected between B1 and B2.
- *2: Use SW3 to select between Sink (NPN, with 24VG common) or Source (PNP, with +24V common) for multi-function digital input terminals S1-S6.
- *3: Use SW2 to switch between voltage and current input for Multi-function analog input 2 (AI2).
- *4: Safety input F1 and F2 is a normally closed input. This input should be closed to enable the inverter output. To activate this input remove the jumper wire between F1 and F2.
- *5. Terminating resistor can be set to ON or bypass (Off). This is used when connecting multiple drives in an RS485 network.

3.9 User Terminals (Control Circuit Terminals)

IP20 Type:

230V: 5 ~ 50 HP, 460V: 5~ 75HP

| | | | | | | | | | | | |
|------|------|----|----|----|-----|------|----|-----|-----|-----|-----|
| S(+) | S(-) | S1 | S3 | S5 | 24V | +10V | MT | GND | GND | AI1 | AI2 |
| E | 24VG | S2 | S4 | S6 | F1 | F2 | PO | P I | AO1 | AO2 | E |

| | | | |
|-----|-----|-----|-----|
| R1A | R1B | R1C | |
| R2A | R2C | R3A | R3C |

230V: 60 ~ 125 HP, 460V: 100 ~ 250HP

| | | | | | | | | | | | |
|------|------|----|----|----|-----|------|----|-----|-----|-----|-----|
| S(+) | S(-) | S1 | S3 | S5 | 24V | +10V | MT | GND | GND | AI1 | AI2 |
| E | 24VG | S2 | S4 | S6 | F1 | F2 | PO | P I | AO1 | AO2 | E |

| | | | | | | |
|-----|-----|-----|-----|-----|-----|-----|
| R1A | R1B | R1C | R2A | R2C | R3A | R3C |
|-----|-----|-----|-----|-----|-----|-----|

Description of User Terminals

| Type | Terminal | terminal function | Signal level / Information |
|----------------------|-------------|--|--|
| Digital input signal | S1 | 2-Wire Forward Run - stop command (default), multi-function input terminals * 1 | Signal Level 24 VDC (opto isolated) Maximum current: 8mA Maximum voltage: 30 Vdc Input impedance: 9.03k Ω |
| | S2 | 2-Wire Reverse Run - stop command (default), multi-function input terminals * 1 | |
| | S3 | Multi-speed/ position setting command 1 (default), multi-function input terminals * 1 | |
| | S4 | Multi-speed/ position setting command 2 (default), multi-function input terminals * 1 | |
| | S5 | Multi-speed/ position setting command 3 (default), multi-function input terminal* 1 | |
| | S6 | Fault reset input, multi-function input terminal * 1 | |
| 24V Power supply | 24V | Digital signal SOURCE (SW3 switched to mode) | $\pm 15\%$, Max. output current: 250mA (The sum of all loads connected) |
| | 24VG | Common terminal for Digital signals Common point for digital signal SINK (SW3 switched to SINK) | |
| Analog input signal | +10V | Power for external speed potentiometer | $\pm 5\%$ (Max. current: 20mA) |
| | MT | Motor temperature detector for eccternally connected PTC | 1330 Ω Range, 550 Ω return |
| | AI1 | Multi-function analog input for speed reference (0-10V input) | Range 0 to +10V Input impedance: 20K Ω Resolution: 12bit |
| | AI2 | Multi-function analog input terminals *2, SW2 switched between voltage or current input (0~10V)/(4-20mA) | Range 0 to +10V Input impedance: 20K Ω Range 4 to 20 mA Input impedance: 250 Ω Resolution: 12bit |
| | GND | Analog signal ground terminal | ---- |
| | E | Shielding wire connecting terminal (Ground) | ---- |
| Analog output signal | AO1 | Multi-function analog output terminals *3 (0~10V/ 4-20mA output) | Range 0 to 10V Max. current: 2mA From 4 to 20 mA |
| | AO2 | Multi-function analog output terminals *3 (0~10V/ 4-20mA output) | |
| | GND | Analog signals ground terminal | |
| Type | Terminal | terminal function | Signal level / Information |
| Pulse output signal | PO | Pulse output, Bandwidth 32KHz | Max. Frequency: 32KHz Open Collector output (Load: 2.2k Ω) |
| | GND | Analog signals ground terminal | ---- |

| | | | |
|----------------------|-------------------------------|--|--|
| Pulse input signal | PI | Pulse command input, bandwidth is 32KHz | L: from 0.0 to 0.5V H: from 4.0 to 13.2V Max. Frequency: 0 - 32KHz Impedance: 3.89 K Ω |
| | GND | Analog signals ground terminal | ---- |
| Relay output | R1A- R1B- R1C- | Relay A contact (multi-function output terminal) Relay B contact (multi-function output terminal) Relay contact common terminal, please refer to parameter group 03 in this manual for function description. | Rating: 250Vac, 10 mA ~ 1A 30Vdc, 10 mA ~ 1A |
| | R2A-R2C | Same functions as R1A/R1B/R1C | Rating: 250Vac, 10 mA ~ 1A 30Vdc, 10 mA ~ 1A |
| | R3A-R3C | Same functions as R1A/R1B/R1C | Rating: 250Vac, 10 mA ~ 1A 30Vdc, 10 mA ~ 1A |
| Run Permissive Input | F1 | On: normal operation. Off: stop. (Jumper wired between F1 and F2 has to be removed by using external contact to stop.) | 24Vdc, 8mA, pull-up |
| | F2 | Safety command common terminal | 24V Ground |
| RS-485 port | S (+) | RS485/MODBUS | Differential input and output |
| | S (-) | | |
| Grounding | E (G) | Grounding to earth Shield the connecting terminal | ---- |

Notes:

*1:Refer to:

- Group 03: External Terminals Digital Input / Output Function Group.

*2:Refer to:

- Group 04 - External Terminal Analog Signal Input (Output) Function Group.

*3:Refer to:

- Group 04 - External Terminal Analog Signal Input (Output) Function Group.

| |
|---|
|  Caution |
| <ul style="list-style-type: none"> • Maximum output current capacity for terminal 10V is 20mA. • Multi-function analog output AO1 and AO2 are intended as analog output meter signals. Do not use them for feedback control. • Control board's 24V and 10V are to be used for internal control only, Do not use the internal power-supply to power external devices. |

3.10 Power Terminals

IP00 / IP20 Type

| Terminal | 230V: 5 ~ 30HP 460V: 5 ~ 40HP | 230V: 40 ~ 125HP 460V: 50 ~ 250HP |
|----------|---|---|
| R/L1 | Input Power Supply (For single phase use terminals R/L1 and S/L2) | |
| S/L2 | | |
| T/L3 | | |
| B1 / P | <ul style="list-style-type: none"> • B1 / P-⊖: DC power supply • B1 / P-B2: external braking resistor | - |
| B2 | | <ul style="list-style-type: none"> • ⊕ -⊖: DC power supply or connect braking module |
| ⊖ | - | |
| ⊕ | - | - |
| U/T1 | Inverter output | |
| V/T2 | | |
| W/T3 | | |
| E | Ground terminal | |

*1. All models 460V 25HP (18.5KW) or below have a built-in braking transistor.

*2. Before connecting DC reactor, please remove factory supplied jumper between terminal ⊕1 and ⊕2.

IP20 Type

230V: 5-7.5HP/ 460V: 5-10HP

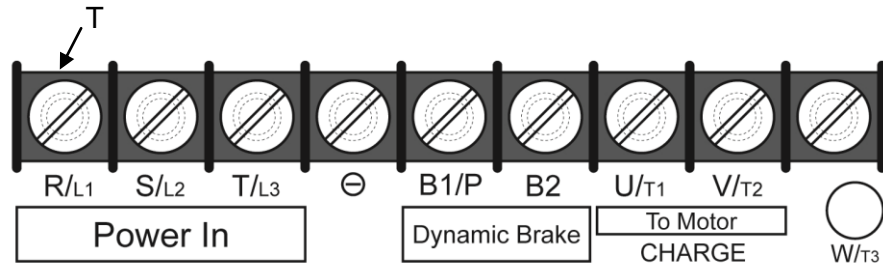

| Terminal screw size | |
|---------------------|----|
| T | ⊖ |
| M4 | M4 |

230V: 10-15HP/ 460V: 15- 20HP

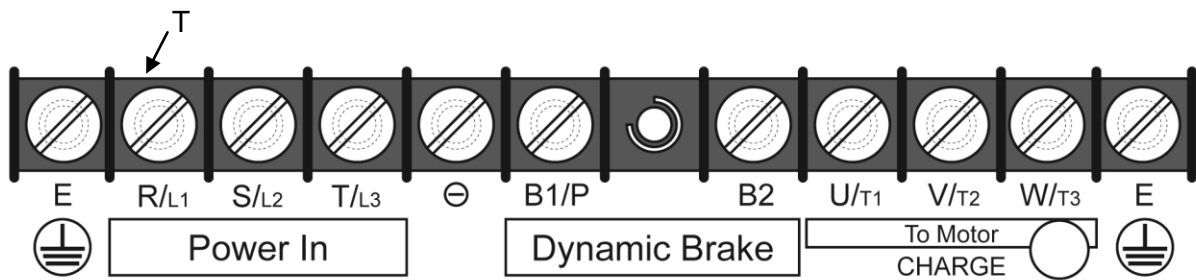

| Terminal screw size | |
|---------------------|----|
| T | ⊖ |
| M4 | M4 |

230V: 20-30HP/ 460V: 25-40HP

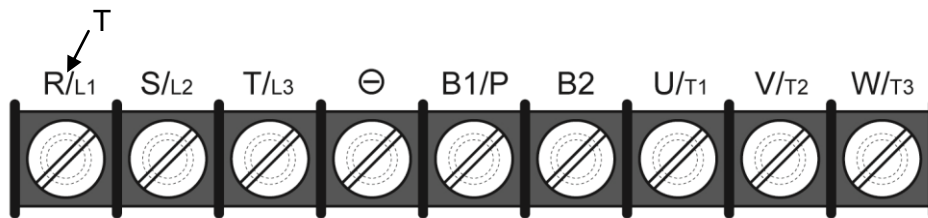

| Terminal screw size | |
|---------------------|----|
| T | ⊖ |
| M6 | M6 |

3.11 Input / Output Power Section Block Diagram

The following diagrams show the basic configuration for IP00/IP20 power sections for the range of horsepower and input voltages. This is shown for reference only and is not a detailed depiction.

IP00/IP20 Type

1: 230V: 5 ~ 30 HP / 460V: 5 ~ 40 HP

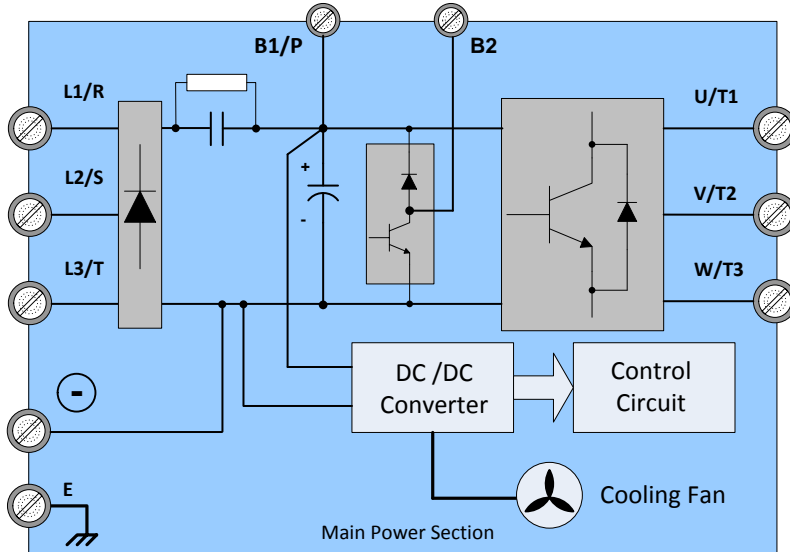

2: 230V: 40 ~ 50 HP / 460V: 50 ~ 76 HP

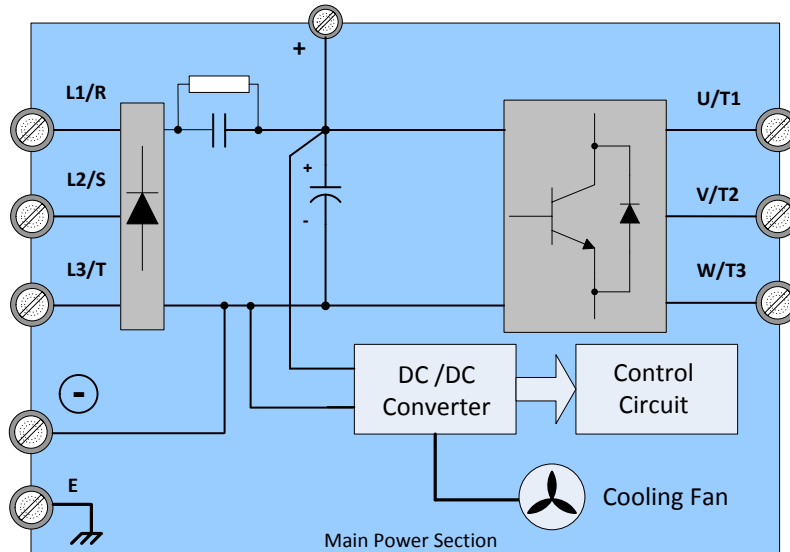

3: 230V: 60 ~ 75 HP / 460V: 100 ~ 125 HP

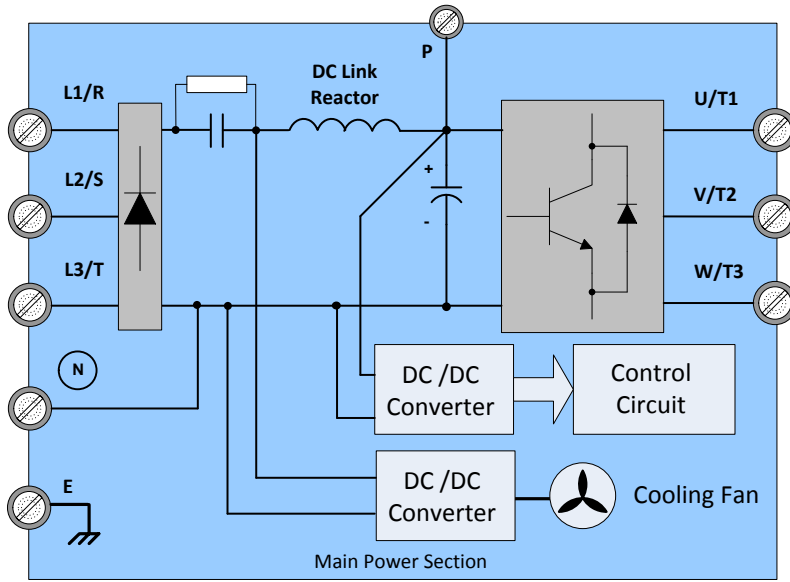

4: 230V: 100 ~ 125 HP

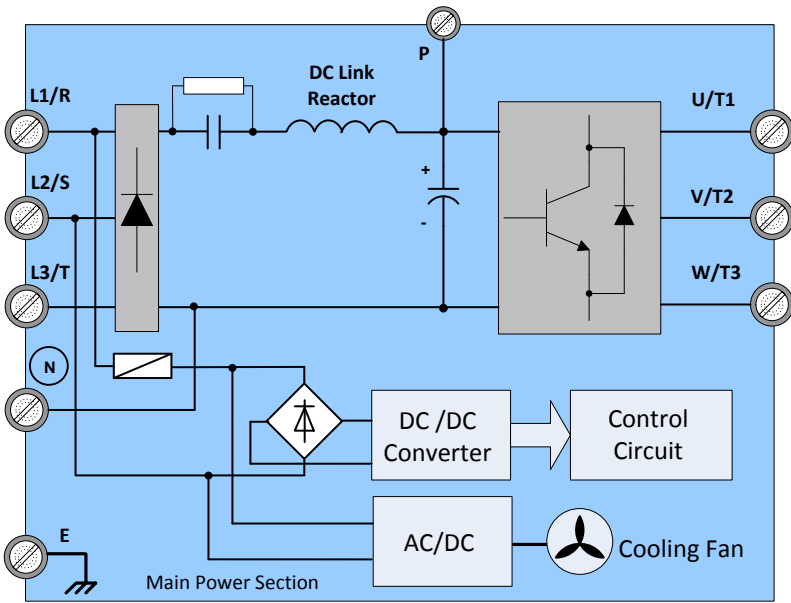

5: 460V: 150 ~ 250 HP

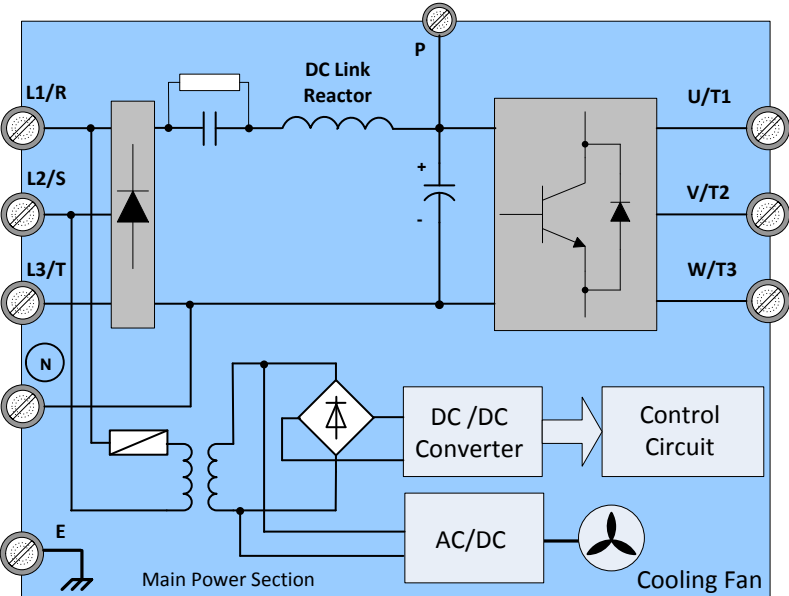

3.11.1 Cooling Fan Supply Voltage Selection (460V class)

The inverter input voltage range of the F510 460V class models ranges from 380 to 480Vac. In these models the cooling fan is directly powered from the power supply. Inverter models F510-4125/ 4150/ 4175/ 4215/ 4250 requires the user to select the correct jumper position based on the inverter input voltage ("460V" is the default position for these models). Please select the correct position according to the input voltage. If the voltage setting is too low, the cooling fan will not provide adequate cooling for the inverter resulting in an over-heat error. If the input voltage is greater than 460Vac, select the "460V" position.

460V: 150 – 250 HP

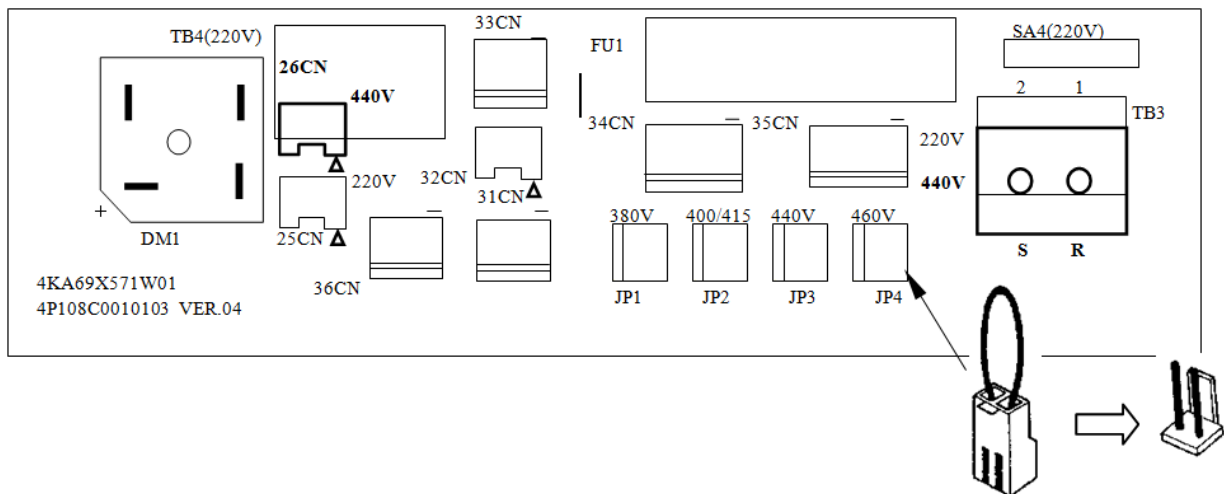

3.12 Inverter Wiring

Wiring Precautions

| | |
|---|---|
|  Danger | <ul style="list-style-type: none">• Do NOT remove any protective covers or attempt any wiring while input power is applied. Connect all wiring before applying input power. When making wiring changes after power up, remove input power and wait a minimum of five minutes after power has been turned off before starting. Also confirm that the charge lamp is off and that DC voltage between terminals B1/P or (+) and (-) does not exceed 25V, otherwise electric shock may result.• Only authorized personnel should work on the equipment. (Remove any metal jewelry such as watches and rings and use insulated tools.), otherwise electric shock or injury may result. |
|---|---|

(A) Power input terminals

1. The Input power supply voltage can be connected in any phase sequence to power input terminals R/L1, S/L2, or T/L3 on the terminal block.
2. DO NOT connect the AC input power source to the output terminals U/T1, V/T2 and. W/T3.
3. Connect the output terminals U/T1, V/T2, W/T3 to motor lead wires U/T1, V/T2, and W/T3, respectively.
4. Check that the motor rotates forward with the forward run source. If it does not, swap any 2 of the output cables to change motor direction.
5. DO NOT connect phase correcting capacitors or LC/RC noise filter to the output circuit.

(B) Grounding

1. Connect the ground terminal (E) to ground having a resistance of less than 100Ω.
2. Do not share the ground wire with other devices, such as welding machines or power tools.
3. Always use a ground wire that complies with the local codes and standards for electrical equipment and minimize the length of ground wire.
4. When using more than one inverter, be careful not to loop the ground wire. See examples below in Fig. 3.12.1.

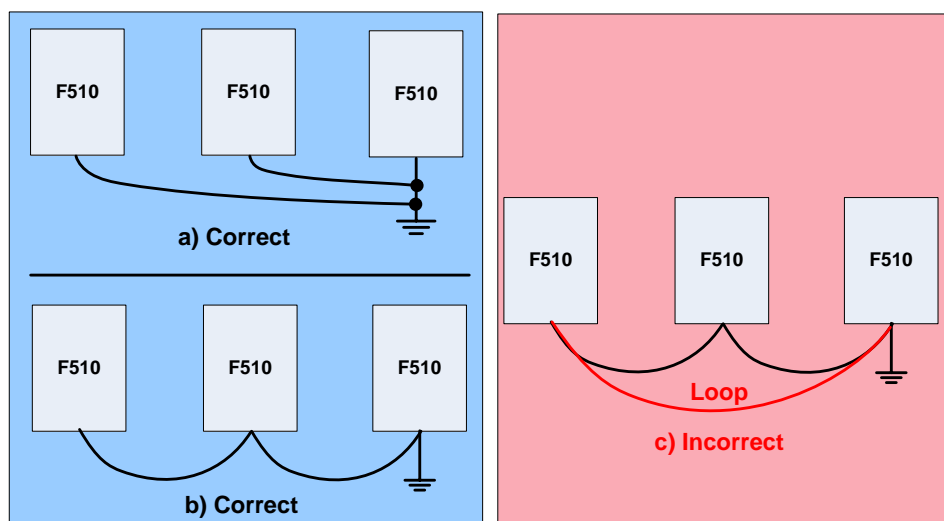

Fig. 3.12.1 Inverter Grounding

3.13 Input Power and Motor Cable Length

The length of the cables between the input power source and /or the motor and inverter can cause a significant phase to phase voltage reduction due to the voltage drop across the cables. The wire size shown in Tables 3.16.1 is based on a maximum voltage drop of 2%. If this value is exceeded, a wire size having larger diameter may be needed. To calculate phase to phase voltage drop, apply the following formula:

$$\text{Phase-to-phase voltage drop (V)} = \sqrt{3} \times \text{resistance of wire } (\Omega/\text{km}) \times \text{length of line (m)} \times \text{current} \times 10^{-3}.$$

(km=3280 x feet)

(m=3.28 x feet)

3.14 Cable Length vs. Carrier Frequency

The allowable setting of the PWM carrier frequency is also determined by motor cable length and is specified in the following Table 3.14.1.

Table 3.14.1 Cable Length vs. Carrier Frequency

| | | | | |
|--|-----------------|------------------------|-------------------------|-------------------|
| Cable length between the inverter and Motor in ft. (m) | <100 (< 30) | 100 – 165 (30 – 50) | 166 - 328 (50 – 100) | ≥ 329 (≥ 100) |
| Recommended carrier frequency allowed Parameter 11-01 | 16kHz (max) | 10 kHz (max) | 5 kHz (max) | 2 kHz (max) |

3.15 Installing an AC Line Reactor

If the inverter is connected to a large-capacity power source (600kVA or more), install an AC reactor on the input side of the inverter. This also improves the power factor on the power supply side.

3.16 Power Input Wire Size, NFB and MCB Part Numbers

The following table shows the recommended wire size, molded case circuit breakers and magnetic contactors for each of the F510 models. It depends on the application whether or not to install a circuit breaker. The NFB must be installed between the input power supply and the inverter input (R/L1, S/L2, T/L3).

Note: When using ground protection make sure the current setting is above 200mA and trip delay time is 0.1 sec or higher.

Table 3.16.1 Wiring instrument for 230V/460V class (IP00/IP20)

| F510 Model | | | | Wire size (mm ²) | | | NFB ³ | MC ³ |
|--------------|------------------|-----------|-------------------|------------------------------|----------------|----------------------------|------------------|-----------------|
| Power supply | Horse power (HP) | Rated KVA | Rated current (A) | Main circuit ^{*1} | Grounding E(G) | Control line ^{*2} | | |
| 230V 3 ∅ | 5HP | 5.5 | 14.5 | 3.5~5.5 | 3.5~5.5 | 0.5~2 | TO-50EC(30A) | CU-16 |
| | 7.5HP | 8.0 | 22 | 5.5 | 5.5 | 0.5~2 | TO-50EC(30A) | CU-16 |
| | 10HP | 11.4 | 30 | 8 | 5.5~8 | 0.5~2 | TO-100S(50A) | CU-18 |
| | 15HP | 15 | 42 | 8 | 5.5~8 | 0.5~2 | TO-100S(50A) | CU-25 |
| | 20HP | 21 | 56 | 14 | 8 | 0.5~2 | TO-100S(100A) | CU-50 |
| | 25HP | 26 | 69 | 22 | 8 | 0.5~2 | TO-100S(100A) | CU-65 |
| | 30HP | 30 | 80 | 22 | 14 | 0.5~2 | TO-225S(100A) | CU-80 |
| | 40HP | 42 | 110 | 38 | 14 | 0.5~2 | TO-225S(150A) | CN-100 |
| | 50HP | 53 | 138 | 60 | 22 | 0.5~2 | TO-225S(175A) | CN-125 |
| | 60HP | 64 | 169 | 80 | 22 | 0.5~2 | TO-225S(200A) | CN-150 |
| | 75HP | 76 | 200 | 100 | 22 | 0.5~2 | TO-225S(225A) | CN-180 |
| | 100HP | 95 | 250 | 150 | 22 | 0.5~2 | TO-400S(300A) | CN-300 |
| | 125HP | 119 | 312 | 200 | 38 | 0.5~2 | TO-400S(400A) | CN-300 |
| 150HP | 152 | 400 | 300 | 38 | 0.5~2 | TO-600S(600A) | S-K400 | |
| 460V 3 ∅ | 5HP | 7.0 | 9.2 | 2~5.5 | 3.5~5.5 | 0.5~2 | TO-50EC(15A) | CU-18 |
| | 7.5HP | 8.5 | 12.1 | 2~5.5 | 3.5~5.5 | 0.5~2 | TO-50EC(15A) | CU-18 |
| | 10HP | 13.3 | 17.5 | 3~5.5 | 3.5~5.5 | 0.5~2 | TO-50EC(20A) | CU-18 |
| | 15HP | 18 | 23 | 5.5 | 5.5 | 0.5~2 | TO-50EC(30A) | CU-25 |
| | 20HP | 24 | 31 | 8 | 8 | 0.5~2 | TO-100S(50A) | CU-25 |
| | 25HP | 29 | 38 | 8 | 8 | 0.5~2 | TO-100S(50A) | CU-35 |
| | 30HP | 34 | 44 | 8 | 8 | 0.5~2 | TO-100S(50A) | CU-50 |
| | 40HP | 41 | 58 | 14 | 8 | 0.5~2 | TO-100S(75A) | CU-50 |
| | 50HP | 55 | 73 | 22 | 8 | 0.5~2 | TO-100S(100A) | CU-65 |
| | 60HP | 67 | 88 | 22 | 14 | 0.5~2 | TO-100S(100A) | CN-80 |
| | 75HP | 79 | 103 | 38 | 14 | 0.5~2 | TO-225S(150A) | CN-100 |
| | 100HP | 111 | 145 | 60 | 22 | 0.5~2 | TO-225S(175A) | CN-150 |
| | 125HP | 126 | 168 | 80 | 22 | 0.5~2 | TO-225S(225A) | CN-150 |
| | 150HP | 159 | 208 | 150 | 22 | 0.5~2 | TO-400S(300A) | CN-300 |
| | 175HP | 191 | 250 | 150 | 22 | 0.5~2 | TO-400S(300A) | CN-300 |
| 215HP | 226 | 296 | 200 | 30 | 0.5~2 | TO-400S(400A) | CN-300 | |
| 250HP | 250 | 328 | 250 | 30 | 0.5~2 | TO-400S(400A) | S-K400 | |

*1. The main circuit terminals: R/L1, S/L2, T/L3 , U/T1, V/T2, W/T3, B1/P, B2, ⊖, ⊕.

*2. Control line is the terminal wire on the control board.

*3. The NFB and MCB listed in the table are of TECO product numbers. Products with same rating from other manufacturers may be used. To reduce electrical noise interference, ensure that on RC surge absorber (R: 10Ω/ 5W, C: 0.1μf/1000VDC) is added to both sides of MCB coil.

Table 3.16.2 Wiring instrument for 230V/460V clas

| Power supply | F510 Model | | | Wire size(mm ²) | | | NFB ^{*3} | MC ^{*3} |
|--------------|------------------|-----------|-------------------|-----------------------------|----------------|----------------------------|-------------------|------------------|
| | Horse power (HP) | Rated KVA | Rated current (A) | Main circuit ^{*1} | Grounding E(G) | Control line ^{*2} | | |
| 460V 3 ∅ | 5HP | 7.0 | 9.2 | 2~5.5 | 3.5~5.5 | 0.5~2 | TO-50EC(15A) | CU-18 |
| | 7.5HP | 8.5 | 12.1 | 2~5.5 | 3.5~5.5 | 0.5~2 | TO-50EC(15A) | CU-18 |
| | 10HP | 13.3 | 17.5 | 3~5.5 | 3.5~5.5 | 0.5~2 | TO-50EC(20A) | CU-18 |
| | 15HP | 18 | 23 | 5.5 | 5.5 | 0.5~2 | TO-50EC(30A) | CU-25 |
| | 20HP | 24 | 31 | 8 | 8 | 0.5~2 | TO-100S(50A) | CU-25 |
| | 25HP | 29 | 38 | 8 | 8 | 0.5~2 | TO-100S(50A) | CU-35 |
| | 30HP | 34 | 44 | 8 | 8 | 0.5~2 | TO-100S(50A) | CU-50 |
| | 40HP | 41 | 58 | 14 | 8 | 0.5~2 | TO-100S(75A) | CU-50 |
| | 50HP | 55 | 73 | 22 | 8 | 0.5~2 | TO-100S(100A) | CU-65 |
| | 60HP | 67 | 88 | 22 | 14 | 0.5~2 | TO-100S(100A) | CN-80 |
| | 75HP | 79 | 103 | 38 | 14 | 0.5~2 | TO-225S(150A) | CN-100 |
| 100HP | 111 | 145 | 60 | 22 | 0.5~2 | TO-225S(175A) | CN-150 | |

*1. The main circuit terminals: R/L1, S/L2, T/L3 , U/T1, V/T2, W/T3, B1/P, B2, ⊖, ⊕.

*2. Control line is the terminal wire on the control board.

*3. The NFB and MCB listed in the table are of TECO product numbers. Products with same rating from other manufacturers may be used. To reduce electrical noise interference, ensure that on RC surge absorber (R: 10Ω/ 5W, C: 0.1μf/1000VDC) is added to both sides of MCB coil.

3.17 Control Circuit Wiring

- (1) Separate the wiring for control circuit terminals from main circuit wiring for terminals (R/L1, S/L2, T/L3, U/T1, V/T2, W/T3).
- (2) Separate the wiring for control circuit terminals R1A-R1B-R1C (or R2A, R2C) (Relay outputs) from wiring for terminals ① - ⑥, A01, A02, GND, DO1, DO2, DOG, +12V, (-12V), AI1, AI2 and GND wiring.
- (3) Use shielded twisted-pair cables (#24 - #14 AWG / 0.5 - 2 mm²) shown in Fig. 3.17.1 for control circuits to minimize noise problems. The maximum wiring distance should not exceed 50m (165 ft).

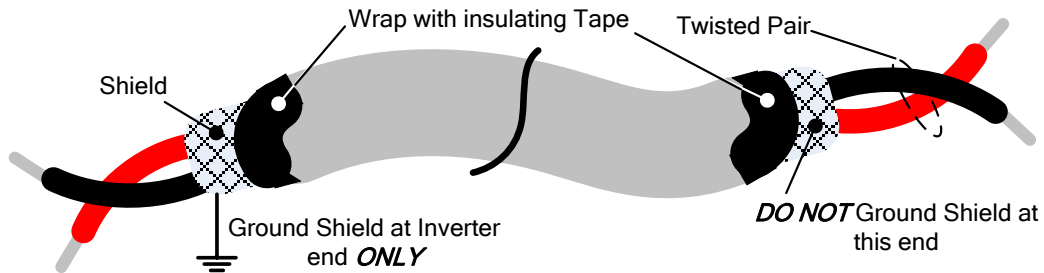

Fig. 3.17.1 Shielded Twisted-Pair

- (4) In Section 3.8 the control boards referenced have a jumper SW3 that can select the digital input to terminals ① - ③ to be set for SINK or SOURCE. The following Fig. 3.17.2 (a.) – (d.) shows examples for the various SINK / Source interfaces.

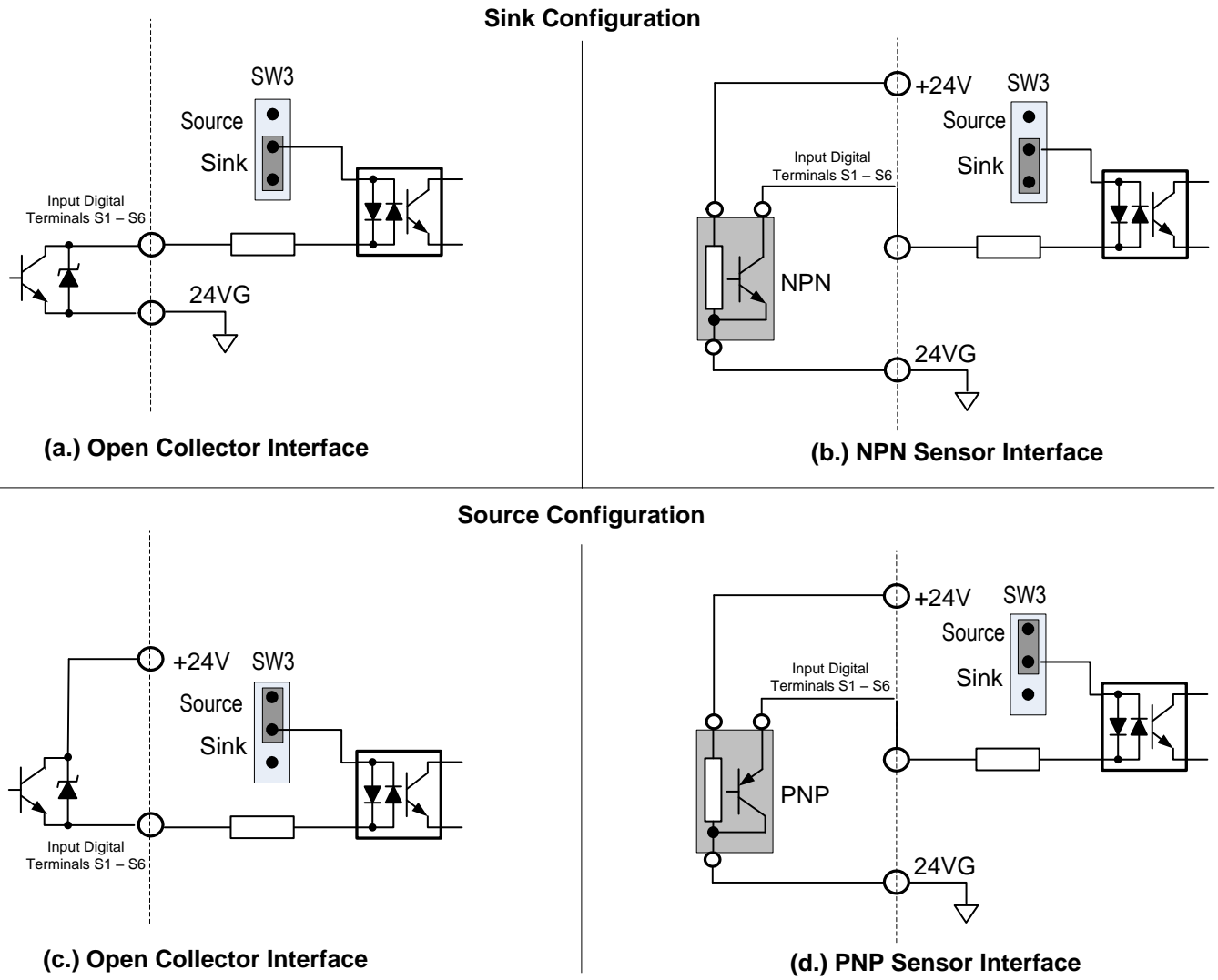

Fig. 3.17.2 Sink / Source Configurations

3.18 Inverter Specification

Basic Specifications 230V class

| Inverter capacity (HP) | | 5 | 7.5 | 10 | 15 | 20 | 25 | 30 | 40 | 50 | 60 | 75 | 100 | 125 | 150 | |
|------------------------|---|---|--------------|-------------|------------|------------|--------------|------------|------------|------------|------------|------------|-------------|-------------|-----|--|
| Output Rated | Rated Output Capacity (KVA) | 5.5 | 8 | 11.4 | 15.2 | 21.3 | 26.2 | 30 | 41.9 | 52.5 | 64.3 | 76.2 | 95.2 | 118.8 | 152 | |
| | Rated Output Current (A) | 14.5 | 22 | 30 | 42 | 56 | 69 | 80 | 110 | 138 | 169 | 200 | 250 | 312 | 400 | |
| | Maximum Applicable Motor ¹ HP (KW) | 5 (3.7) | 7.5 (5.5) | 10 (7.5) | 15 (11) | 20 (15) | 25 (18.5) | 30 (22) | 40 (30) | 50 (37) | 60 (45) | 75 (55) | 100 (75) | 125 (90) | 150 | |
| | Maximum Output Voltage (V) | 3-phase 230V~240V | | | | | | | | | | | | | | |
| | Maximum Output Frequency (Hz) | Based on parameter setting 0.1~400.0 Hz | | | | | | | | | | | | | | |
| Power supply | Rated Voltage, Frequency | 3-phase 230V~240V, 50/60Hz | | | | | | | | | | | | | | |
| | Allowable Voltage Fluctuation | -15% ~ +10% | | | | | | | | | | | | | | |
| | Allowable Frequency Fluctuation | ±5% | | | | | | | | | | | | | | |

Basic Specifications 460V class

| Inverter capacity (HP) | | 5 | 7.5 | 10 | 15 | 20 | 25 | 30 | 40 | 50 | 60 | 75 | 100 | 125 | 150 | 175 | 215 | 250 | |
|------------------------|---|---|--------------|-------------|------------|------------|--------------|------------|------------|------------|------------|------------|-------------|-------------|--------------|--------------|--------------|--------------|--|
| Output Rated | Rated Output Capacity (KVA) | 7.0 | 8.4 | 13.3 | 17.5 | 23.6 | 28.9 | 33.5 | 41.1 | 54.8 | 67 | 78.4 | 110 | 125 | 158 | 190 | 225 | 250 | |
| | Rated Output Current (A) | 9.2 | 12.1 | 17.5 | 23 | 31 | 38 | 44 | 58 | 73 | 88 | 103 | 145 | 168 | 208 | 250 | 296 | 328 | |
| | Maximum Applicable Motor ¹ HP (KW) | 5 (3.7) | 7.5 (5.5) | 10 (7.5) | 15 (11) | 20 (15) | 25 (18.5) | 30 (22) | 40 (30) | 50 (37) | 60 (45) | 75 (55) | 100 (75) | 125 (90) | 150 (110) | 175 (132) | 215 (160) | 250 (185) | |
| | Maximum Output Voltage (V) | 3-phase 380V~480V | | | | | | | | | | | | | | | | | |
| | Maximum Output Frequency (Hz) | Based on parameter setting 0.1~400.0 Hz | | | | | | | | | | | | | | | | | |
| Power supply | Rated Voltage, Frequency | 3-phase 380V~480V, 50/60Hz | | | | | | | | | | | | | | | | | |
| | Allowable Voltage Fluctuation | -15% ~ +10% | | | | | | | | | | | | | | | | | |
| | Allowable Frequency Fluctuation | ±5% | | | | | | | | | | | | | | | | | |

*1: Take standard 4-pole induction motor as the base.

*2: F510 model is designed to be used in variable torque (VT) application with overload capability of 120% for 1 min.

The following table shows the maximum output frequency for each control mode.

| Control mode | Other settings | Maximum output frequency |
|--------------|---|--------------------------|
| V/F | Unlimited | 400Hz |
| SLV | 230V 5~15HP, 460V 5~20HP | 150Hz |
| | 230V 20~30HP, 460V 25HP | 110Hz |
| | 460V 30~40HP | 100Hz |
| | 230V 40~125HP, 460V 50~215HP, carrier (11-01) is set as 8K or below 8K. | 100Hz |
| | 230V 40~125HP, 460V 50~215HP, carrier (11-01) is set as above 8K. | 80Hz |
| | 230V 150~175HP, 460V 250~800HP | 100Hz |
| PMSLV | Unlimited | 400Hz |

3.19 General Specifications

| | | |
|-------------------------|---|--|
| Control Characteristics | Operation Modes | LED keypad with seven-segment display *5 and LCD keypad (Optional HOA LCD keypad); all LCD keypad with parameter copy function |
| | Control Modes | V/F, SLV, PMSLV with space vector PWM mode |
| | Frequency Control Range | 0.1Hz~400.0Hz |
| | Frequency Accuracy (Temperature change) | Digital references: $\pm 0.01\%$ (-10 to +40°C), Analog references: $\pm 0.1\%$ (25°C $\pm 10^\circ\text{C}$) |
| | Speed Control Accuracy | $\pm 0.5\%$ (Sensorless Vector Control Mode) ^{*1} |
| | Frequency Setting Resolution | Digital references: 0.01Hz , Analog references: 0.06Hz/60Hz |
| | Output Frequency Resolution | 0.01Hz |
| | Inverter Overload | 120%/1 min |
| | Frequency Setting Signal | DC 0~+10V / 0~20mA or 4~20mA |
| | Acceleration/Deceleration Time | 0.0~6000.0 seconds (separately set acceleration and deceleration time) |
| | Voltage, Frequency Characteristics | Custom V/F curve based on parameters |
| | Braking Torque | About 20% |
| | Main Control Functions | Auto tuning, Soft-PWM, Over voltage protection, Dynamic braking, Speed search, Restart upon momentary power loss, 2 sets of PID control, Slip Compensation, RS-485 communication standard, Simple PLC function, 2 sets of analog outputs, Safety switch |
| | Other Functions | Accumulated power-on/ run time, 4 sets of fault history records and latest fault record state, Energy-saving function setting, Phase loss protection, Smart braking, DC braking, Dwell · S curve acceleration and deceleration, Up/Down operation, Modbus, BACnet MS/TP and Metasys N2 communication protocol, Display of multi-engineering unit, Local/ Remote switch, SINK/SOURCE input interface selection, User parameter settings |
| Protection Function | Stall Prevention | Current level can be setting (It can be set separately in acceleration or constant speed; it can be set with or without protection in deceleration) |
| | Instantaneous Over Current (OC) and Output Short-Circuit (SC) Protection | Inverter stops when the output current exceeds 160% of the inverter rated current |
| | Inverter Overload Protection (OL2) | If inverter rated current 120%/1min is exceeded, inverter stops. The factory default carrier frequency is 2~4KHZ ^{*2} |
| | Motor Overload Protection (OL1) | Electrical overload protection curve |
| | Over voltage (OV) Protection | If the main circuit DC voltage rises over 410V (230V class)/ 820V (460V class), the motor stops running. |
| | Under voltage (UV) Protection | If the main circuit DC voltage falls below 190V (230V class) /380V (460V class), the motor stops running. |
| | Auto-Restart after Momentary Power Loss | Power loss exceeds 15ms. Auto-restart function available after momentary power loss in 2 sec. |
| | Overheat(OH) Protection | Use temperature sensor for protection. |
| | Ground Fault (GF) Protection | Use current sensor for protection. |
| | DC Bus Charge Indicator | When main circuit DC voltage $\geq 50\text{V}$, the CHARGE LED turns on. |
| | Output Phase Loss (OPL) Protection | If the OPL is detected, the motor stops automatically. |

| | | |
|-----------------------------------|-------------------------------|---|
| Environment Specifications | Installation Location | Indoor (protected from corrosive gases and dust) |
| | Ambient Temperature | -10~+40°C(14°F~104°F) (IP20/NEMA1 or NEMA12), -10~+50°C(14°F~122°F) (IP00) without de-rating; with de-rating, its maximum operation temperature is 60°C(140°F). |
| | Storage Temperature | -20~+70°C(-4°F~+158°F) |
| | Humidity | 95%RH or less (no condensation) |
| | Altitude and Vibration | Altitude of 1000m (3181ft) or below, below 5.9m/s2(0.6G) |
| Communication Function | | Built-in RS-485 as standard (Modbus protocol with RJ45/ BACnet/ Metasys N2) |
| PLC Function | | Built-in |
| EMI Protection | | The built-in noise filter complies with EN61800-3 available for inverters 460V 75HP or below (IP20) / 460V 60HP or below |
| EMS Protection | | in compliance with EN61800-3 |
| Safety Certification | CE Declaration | in compliance with EN61800-3 (CE & RE) and EN61800-5-1 (LVD, Low-Voltage Directive) |
| | UL Certification | UL508C |
| Accessories | | 1 to 8 Pump card, HOA keypad, Profibus card |

*1: Speed control accuracy will be different from the installation conditions and motor types.

*2: The factory default carrier frequency varies with each rating rating.

3.20 Inverter Derating Based on Carrier Frequency

230V Models

Note: Derating curve current of carrier frequency means inverter rated current.

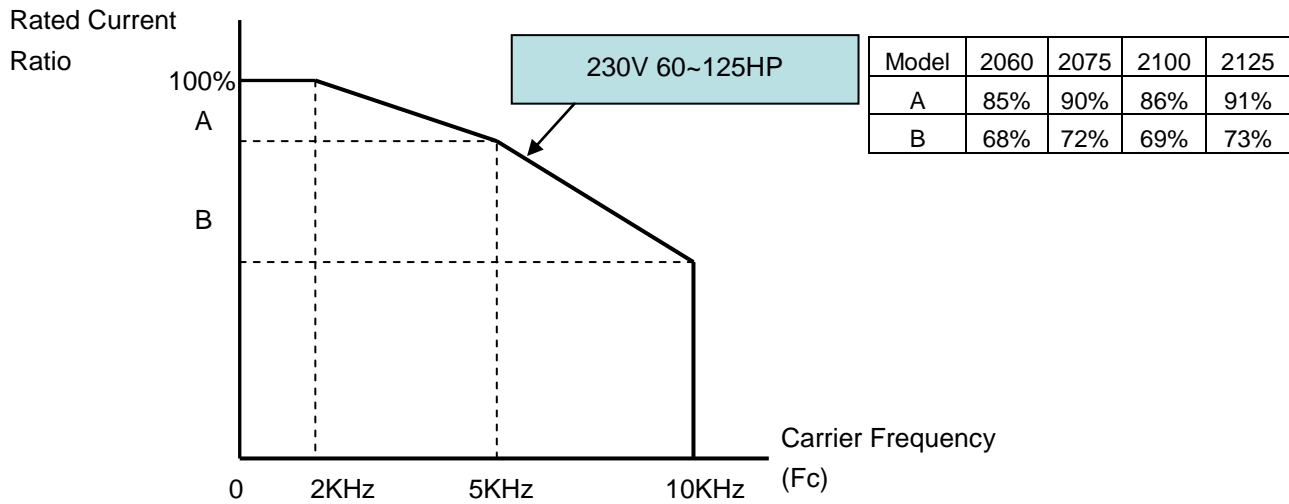
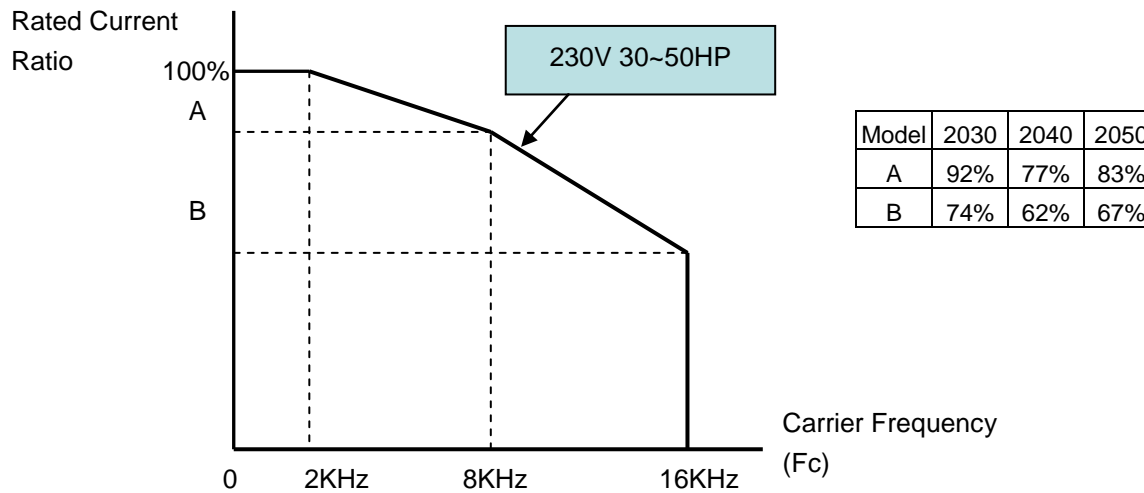
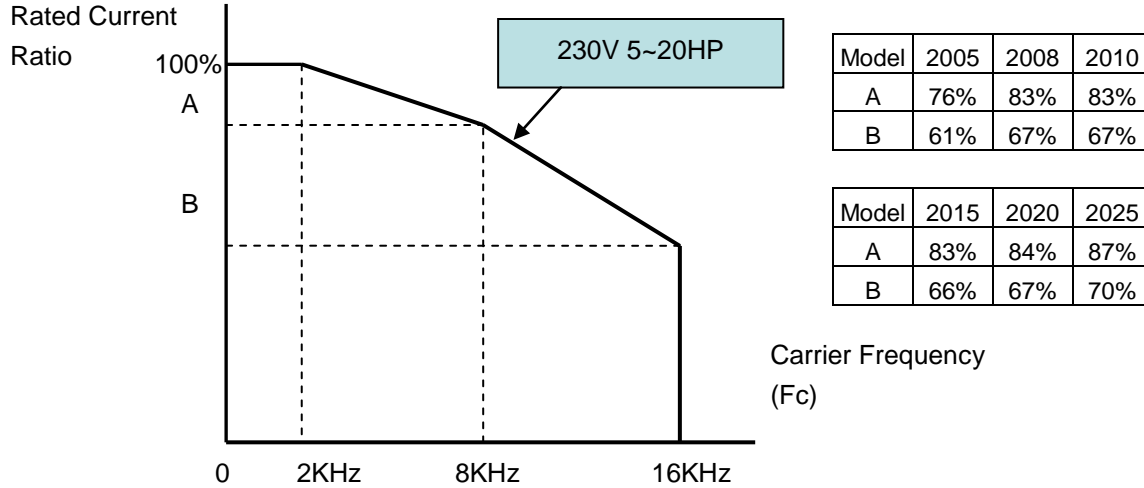

460V Models

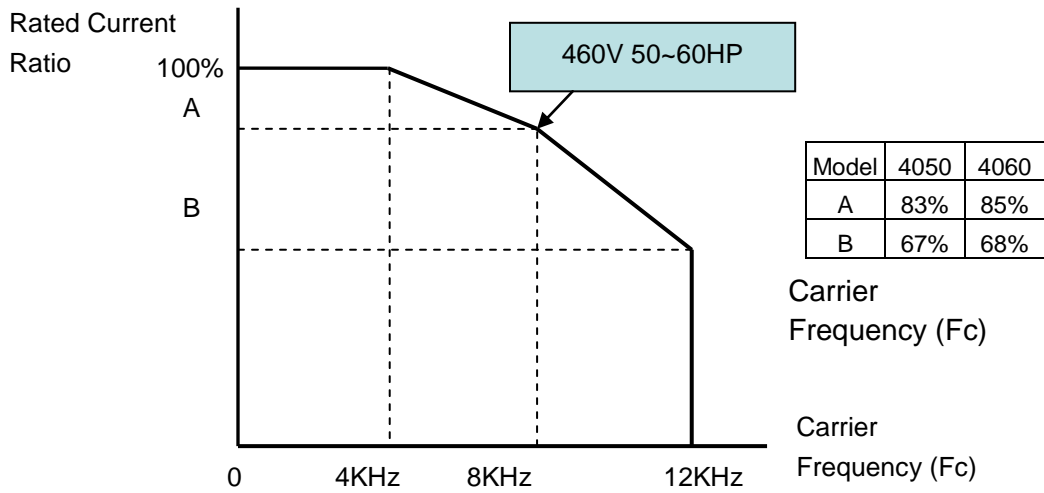
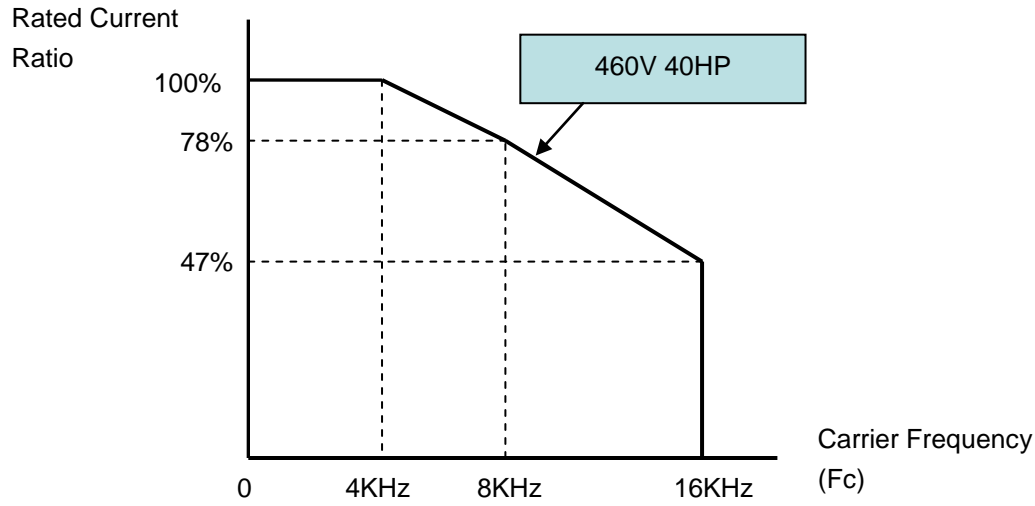
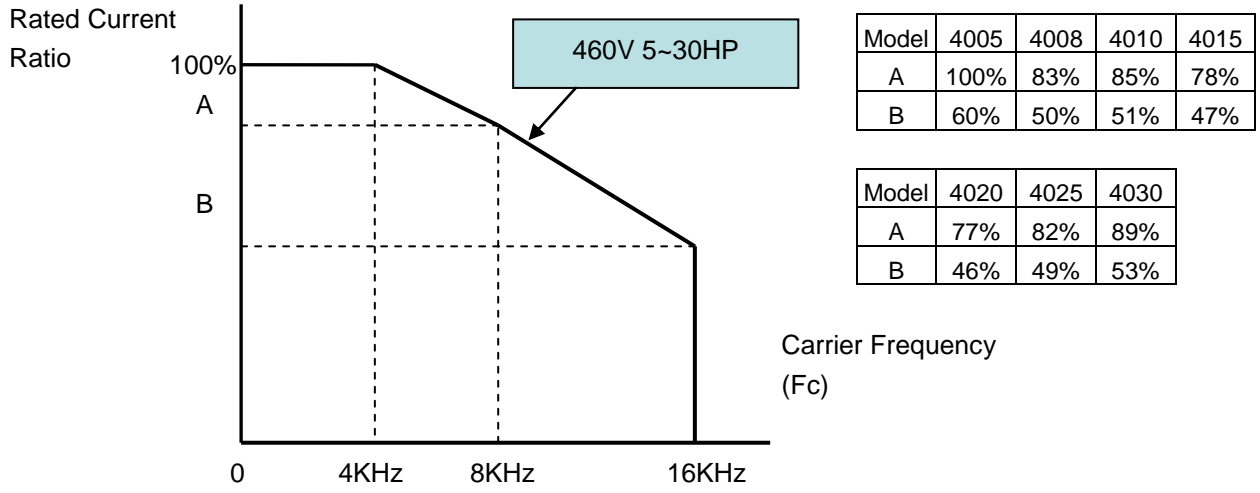

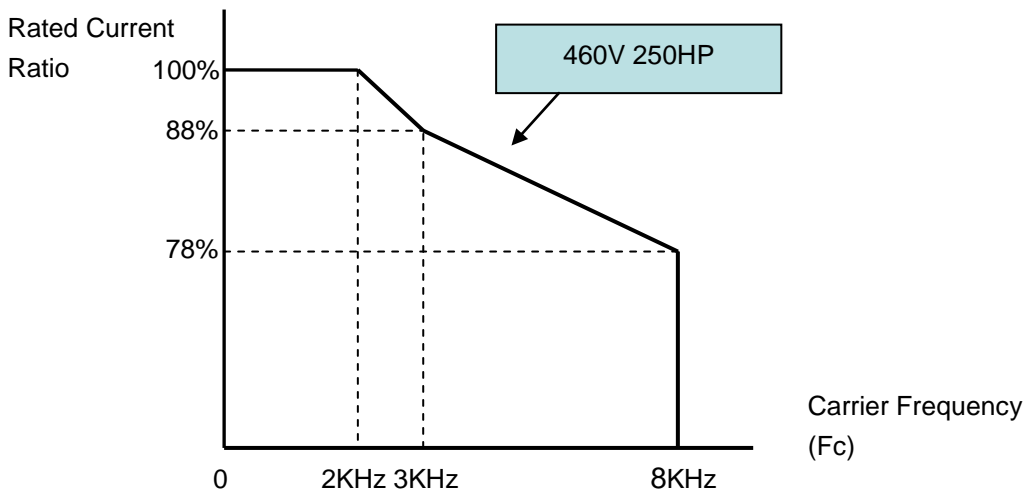
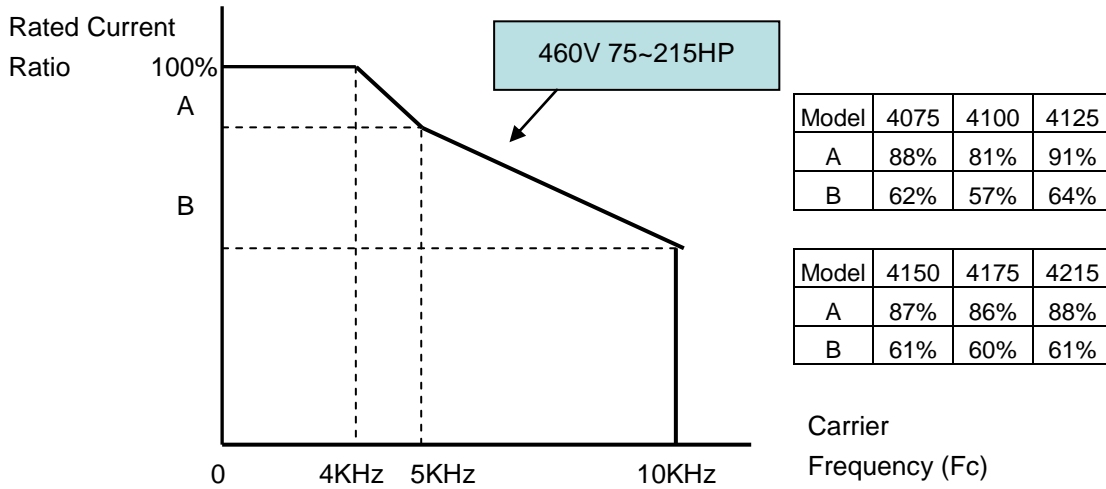

3.21 Inverter Derating Based on Temperature

Note: Adjust the inverter rated current for ambient temperature to ensure the appropriate application.

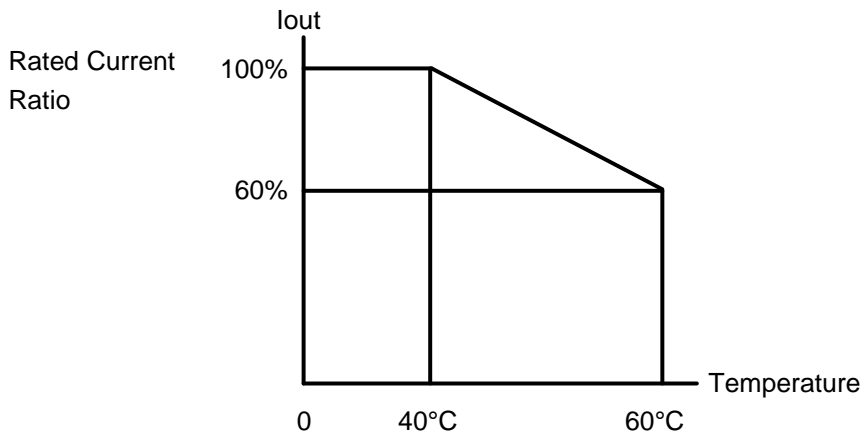

3.22 Inverter Dimensions (IP00 / IP20)

(a) 230V: 5-7.5HP/ 460V: 5-10HP

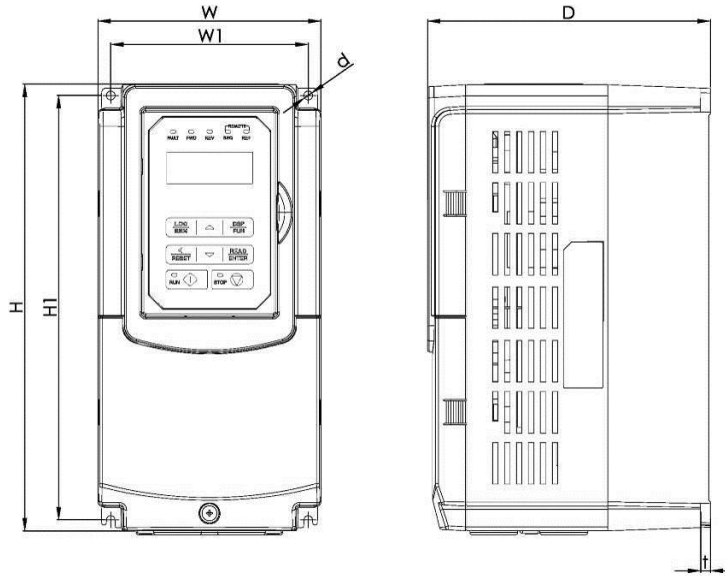

| Inverter Model | Dimensions in inch (mm) | | | | | | d | NW in lbs (kg) |
|----------------|-------------------------|----------------|---------------|---------------|----------------|-------------|----|----------------|
| | W | H | D | W1 | H1 | t | | |
| F510-2005-C3 | 5.51 (140) | 10.98 (279) | 6.97 (177) | 4.80 (122) | 10.51 (267) | 0.28 (7) | M6 | 8.38 (3.8) |
| F510-2008-C3 | 5.51 (140) | 10.98 (279) | 6.97 (177) | 4.80 (122) | 10.51 (267) | 0.28 (7) | M6 | 8.38 (3.8) |
| F510-4005-C3 | 5.51 (140) | 10.98 (279) | 6.97 (177) | 4.80 (122) | 10.51 (267) | 0.28 (7) | M6 | 8.38 (3.8) |
| F510-4008-C3 | 5.51 (140) | 10.98 (279) | 6.97 (177) | 4.80 (122) | 10.51 (267) | 0.28 (7) | M6 | 8.38 (3.8) |
| F510-4010-C3 | 5.51 (140) | 10.98 (279) | 6.97 (177) | 4.80 (122) | 10.51 (267) | 0.28 (7) | M6 | 8.38 (3.8) |

(b) 230V: 10-30HP/ 460V: 15-40HP (IP20)

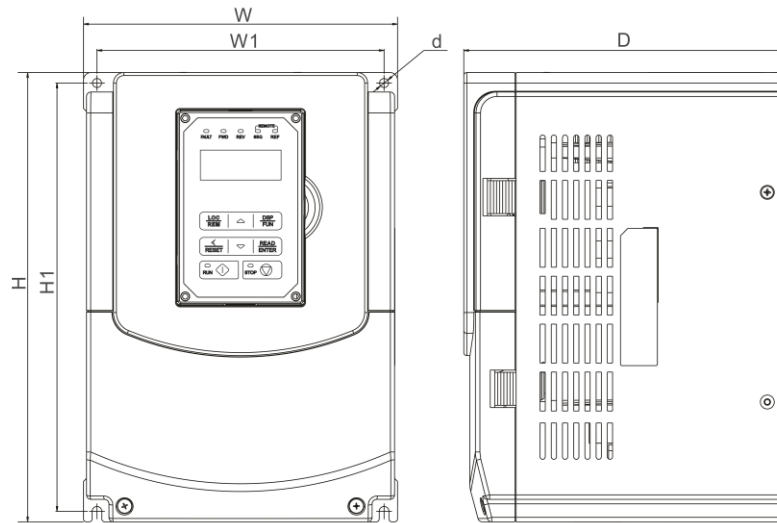

| Inverter Model | Dimensions in inch (mm) | | | | | | d | NW in lbs (kg) |
|----------------|-------------------------|----------------|---------------|---------------|----------------|---------------|----|----------------|
| | W | H | D | W1 | H1 | t | | |
| F510-2010-C3 | 8.27 (210) | 11.81 (300) | 8.46 (215) | 7.56 (192) | 11.26 (286) | 0.06 (1.6) | M6 | 13.67 (6.2) |
| F510-2015-C3 | 8.27 (210) | 11.81 (300) | 8.46 (215) | 7.56 (192) | 11.26 (286) | 0.06 (1.6) | M6 | 13.67 (6.2) |
| F510-2020-C3 | 10.43 (265) | 14.17 (360) | 8.86 (225) | 9.65 (245) | 13.39 (340) | 0.06 (1.6) | M8 | 22.05 (10) |
| F510-2025-C3 | 10.43 (265) | 14.17 (360) | 8.86 (225) | 9.65 (245) | 13.39 (340) | 0.06 (1.6) | M8 | 22.05 (10) |
| F510-2030-C3 | 10.43 (265) | 14.17 (360) | 8.86 (225) | 9.65 (245) | 13.39 (340) | 0.06 (1.6) | M8 | 22.05 (10) |
| F510-4015-C3 | 8.27 (210) | 11.81 (300) | 8.46 (215) | 7.56 (192) | 11.26 (286) | 0.06 (1.6) | M6 | 13.67 (6.2) |
| F510-4020-C3 | 8.27 (210) | 11.81 (300) | 8.46 (215) | 7.56 (192) | 11.26 (286) | 0.06 (1.6) | M6 | 13.67 (6.2) |
| F510-4025-C3 | 10.43 (265) | 14.17 (360) | 8.86 (225) | 9.65 (245) | 13.39 (340) | 0.06 (1.6) | M8 | 22.05 (10) |
| F510-4030-C3 | 10.43 (265) | 14.17 (360) | 8.86 (225) | 9.65 (245) | 13.39 (340) | 0.06 (1.6) | M8 | 22.05 (10) |
| F510-4040-C3 | 10.43 (265) | 14.17 (360) | 8.86 (225) | 9.65 (245) | 13.39 (340) | 0.06 (1.6) | M8 | 22.05 (10) |

(c) 230V: 40-50HP/ 460V: 50-75HP (IP00)

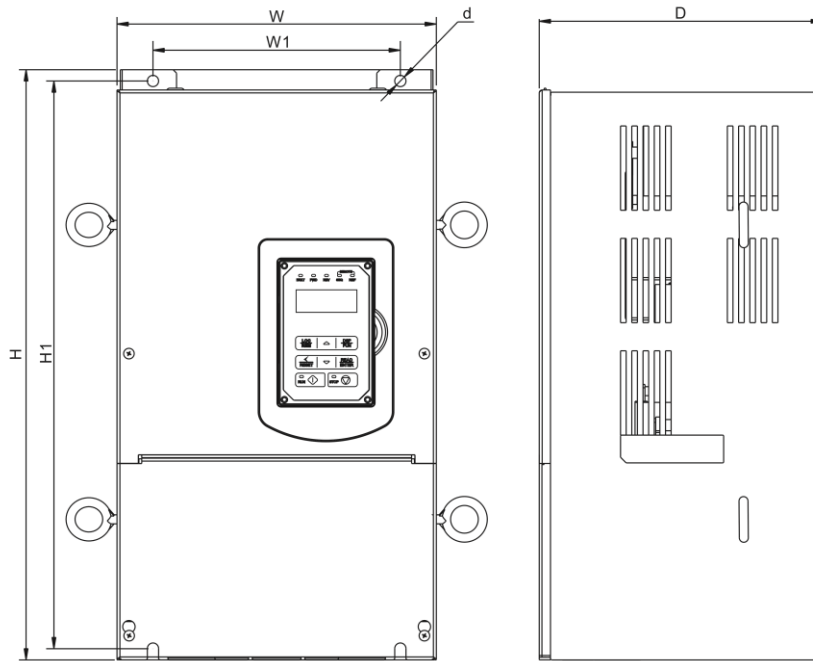

| Inverter Model | Dimensions in inch (mm) | | | | | | d | NW in lbs (kg) |
|----------------|-------------------------|----------------|---------------|---------------|----------------|---------------|----|----------------|
| | W | H | D | W1 | H1 | t | | |
| F510-2040-C3 | 11.18 (284) | 20.67 (525) | 9.92 (252) | 8.66 (220) | 19.88 (505) | 0.06 (1.6) | M8 | 66.14 (30) |
| F510-2050-C3 | 11.18 (284) | 20.67 (525) | 9.92 (252) | 8.66 (220) | 19.88 (505) | 0.06 (1.6) | M8 | 66.14 (30) |
| F510-4050-C3 | 11.18 (284) | 20.67 (525) | 9.92 (252) | 8.66 (220) | 19.88 (505) | 0.06 (1.6) | M8 | 66.14 (30) |
| F510-4060-C3 | 11.18 (284) | 20.67 (525) | 9.92 (252) | 8.66 (220) | 19.88 (505) | 0.06 (1.6) | M8 | 66.14 (30) |
| F510-4075-C3 | 11.18 (284) | 20.67 (525) | 9.92 (252) | 8.66 (220) | 19.88 (505) | 0.06 (1.6) | M8 | 66.14 (30) |

(d) 230V: 60-125HP/ 460V: 100-250HP (IP00)

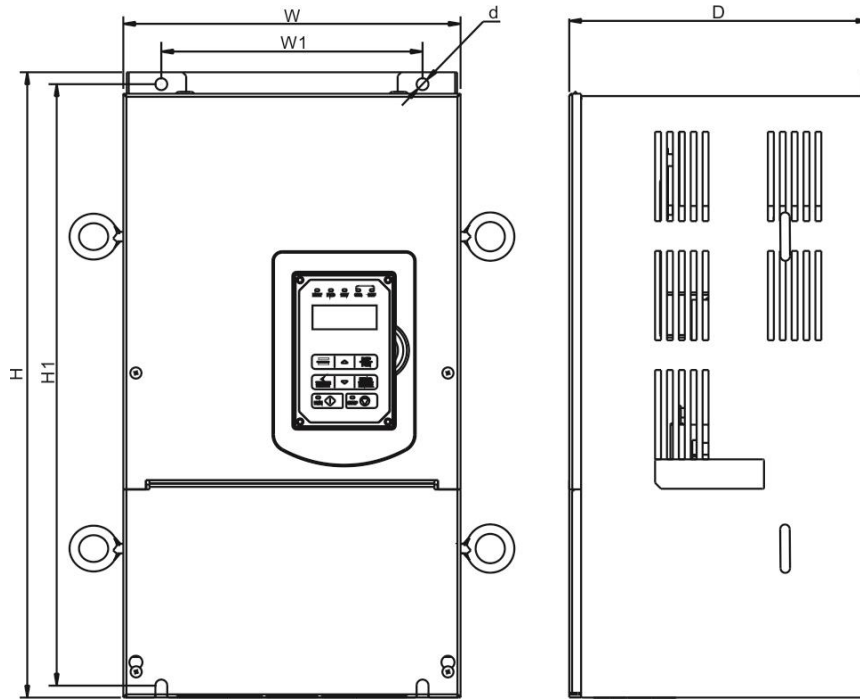

| Inverter Model | Dimensions in inch (mm) | | | | | | d | NW in lbs (kg) |
|----------------|-------------------------|----------------|------------------|----------------|----------------|---------------|-----|-----------------|
| | W | H | D | W1 | H1 | t | | |
| F510-2060-C3 | 13.54 (344) | 22.83 (580) | 11.81 (300) | 9.84 (250) | 22.05 (560) | 0.06 (1.6) | M10 | 89.29 (40.5) |
| F510-2075-C3 | 13.54 (344) | 22.83 (580) | 11.81 (300) | 9.84 (250) | 22.05 (560) | 0.06 (1.6) | M10 | 89.29 (40.5) |
| F510-2100-C3 | 18.07 (459) | 31.10 (790) | 12.78 (324.5) | 12.60 (320) | 29.92 (760) | 0.06 (1.6) | M10 | 163.14 (74) |
| F510-2125-C3 | 18.07 (459) | 31.10 (790) | 12.78 (324.5) | 12.60 (320) | 29.92 (760) | 0.06 (1.6) | M10 | 163.14 (74) |
| F510-4100-C3 | 13.54 (344) | 22.83 (580) | 11.81 (300) | 9.84 (250) | 22.05 (560) | 0.06 (1.6) | M10 | 89.29 (40.5) |
| F510-4125-C3 | 13.54 (344) | 22.83 (580) | 11.81 (300) | 9.84 (250) | 22.05 (560) | 0.06 (1.6) | M10 | 89.29 (40.5) |
| F510-4150-C3 | 18.07 (459) | 31.10 (790) | 12.78 (324.5) | 12.60 (320) | 29.92 (760) | 0.06 (1.6) | M10 | 163.14 (74) |
| F510-4175-C3 | 18.07 (459) | 31.10 (790) | 12.78 (324.5) | 12.60 (320) | 29.92 (760) | 0.06 (1.6) | M10 | 163.14 (74) |
| F510-4215-C3 | 18.07 (459) | 31.10 (790) | 12.78 (324.5) | 12.60 (320) | 29.92 (760) | 0.06 (1.6) | M10 | 163.14 (74) |
| F510-4250-C3 | 18.07 (459) | 31.10 (790) | 12.78 (324.5) | 12.60 (320) | 29.92 (760) | 0.06 (1.6) | M10 | 163.14 (74) |

(e) 230V: 60-125HP/ 460V: 100-250HP (IP20)

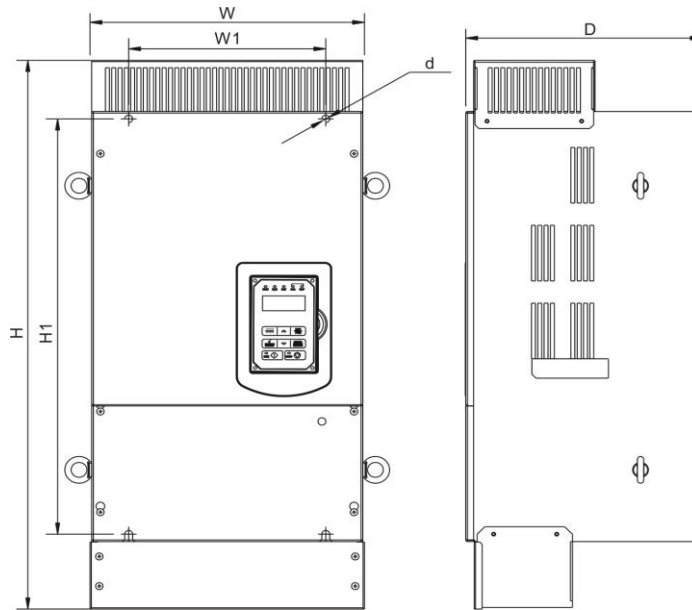

| Inverter Model | Dimensions in inch (mm) | | | | | | d | NW in lbs (kg) |
|----------------|-------------------------|-----------------|------------------|----------------|----------------|----------------|-----|------------------|
| | W | H | D | W1 | H1 | t | | |
| F510-2060-C3 | 13.72 (348.5) | 29.13 (740) | 11.81 (300) | 9.84 (250) | 22.05 (560) | 0.06 (1.6) | M10 | 97.00 (44) |
| F510-2075-C3 | 13.72 (348.5) | 29.13 (740) | 11.81 (300) | 9.84 (250) | 22.05 (560) | 0.06 (1.6) | M10 | 97.00 (44) |
| F510-2100-C3 | 18.25 (463.5) | 43.50 (1105) | 12.78 (324.5) | 12.60 (320) | 29.92 (760) | 0.06 (1.6) | M10 | 178.57 (81) |
| F510-2125-C3 | 18.25 (463.5) | 43.50 (1105) | 12.78 (324.5) | 12.60 (320) | 29.92 (760) | 0.06 (1.6) | M10 | 178.57 (81) |
| F510-2150-C3 | 27.17 (690) | 39.37 (1000) | 16.14 (410) | 20.87 (530) | 10.43 (265) | 37.80 (960) | M10 | 405.651 (184) |
| F510-4100-C3 | 13.72 (348.5) | 29.13 (740) | 11.81 (300) | 9.84 (250) | 22.05 (560) | 0.06 (1.6) | M10 | 97.00 (44) |
| F510-4125-C3 | 13.72 (348.5) | 29.13 (740) | 11.81 (300) | 9.84 (250) | 22.05 (560) | 0.06 (1.6) | M10 | 97.00 (44) |
| F510-4150-C3 | 18.25 (463.5) | 43.50 (1105) | 12.78 (324.5) | 12.60 (320) | 29.92 (760) | 0.06 (1.6) | M10 | 178.57 (81) |
| F510-4175-C3 | 18.25 (463.5) | 43.50 (1105) | 12.78 (324.5) | 12.60 (320) | 29.92 (760) | 0.06 (1.6) | M10 | 178.57 (81) |
| F510-4215-C3 | 18.25 (463.5) | 43.50 (1105) | 12.78 (324.5) | 12.60 (320) | 29.92 (760) | 0.06 (1.6) | M10 | 178.57 (81) |
| F510-4250-C3 | 18.25 (463.5) | 43.50 (1105) | 12.78 (324.5) | 12.60 (320) | 29.92 (760) | 0.06 (1.6) | M10 | 178.57 (81) |

4. Keypad and Programming Functions

4.1 LCD Keypad

4.1.1 Keypad Display and Keys



| DISPLAY | Description |
|-----------------------|---|
| LCD Display | Monitor inverter signals, view / edit parameters, fault / alarm display. |
| LED INDICATORS | |
| FAULT | LED ON when a fault or alarm is active. |
| FWD | LED ON when inverter is running in forward direction, flashing when stopping. |
| REV | On when inverter is running in reverse direction, flashing when stopping. |
| SEQ | LED ON when RUN command is from the external control terminals or from serial communication |
| REF | LED ON when Frequency Reference command is from the external control terminals or from serial communication |

| KEYS (8) | Description |
|---------------------|--|
| RUN | RUN Inverter in Local Mode |
| STOP | STOP Inverter |
| ▲ | Parameter navigation Up, Increase parameter or reference value |
| ▼ | Parameter navigation Down, Decrease parameter or reference value |
| FWD/REV | Used to switch between Forward and Reverse direction |
| DSP/FUN | Used to scroll to next screen Frequency screen →Function selection→Monitor parameter |
| ◀ / RESET | Selects active seven segment digit for editing with the ▲ ▼ keys Used to reset fault condition. |
| READ / ENTER | Used to read and save the value of the active parameter |

Auto-Repeat Keys

Holding the ▲UP or ▼DOWN key for a longer period of time will initiate the auto-repeat function resulting in the value of the selected digit to automatically increase or decrease.

Note: HOA LCD keypad is available as an option.

4.1.2 Keypad Menu Structure

Main Menu

The A510 inverter main menu consists of two main groups (modes). The DSP/FUN key is used to switch between the monitor mode and the parameter group mode.

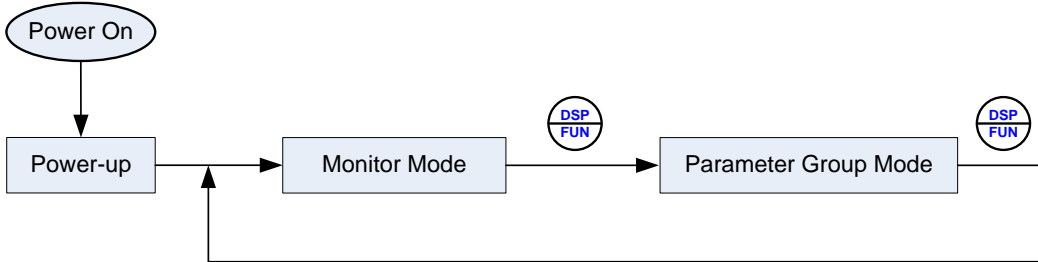

| Mode | Description |
|----------------------|---|
| Monitor Mode | View inverter status, signals and fault data. |
| Parameter Group Mode | Access to available parameter groups. |

All the available parameter groups are listed in the Parameter Group Mode use the up and down keys to select a group and press Read/Enter key to access its parameters.

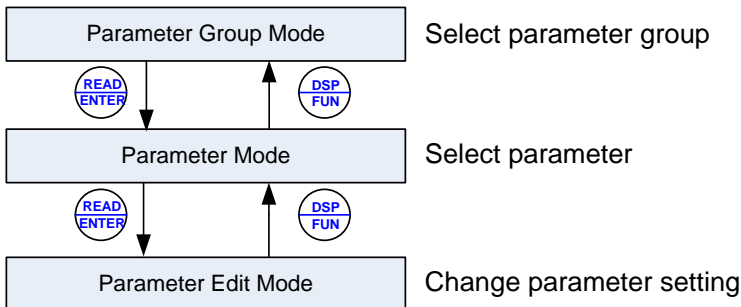

Fig. 4.1.2.1 Parameter Group Structure

Notes:

- Always perform an auto-tune on the motor before operating the inverter in vector control (sensorless vector). Auto-tuning mode will not be displayed when the inverter is running or when a fault is active.
- To scroll through the available modes, parameter groups or parameter list press and hold the up or down key.

Monitor Mode

In monitor mode inverter signals can be monitored such as output frequency, output current and output voltage, etc...) as well as fault information and fault trace. See Fig 4.1.2.2 for keypad navigation.

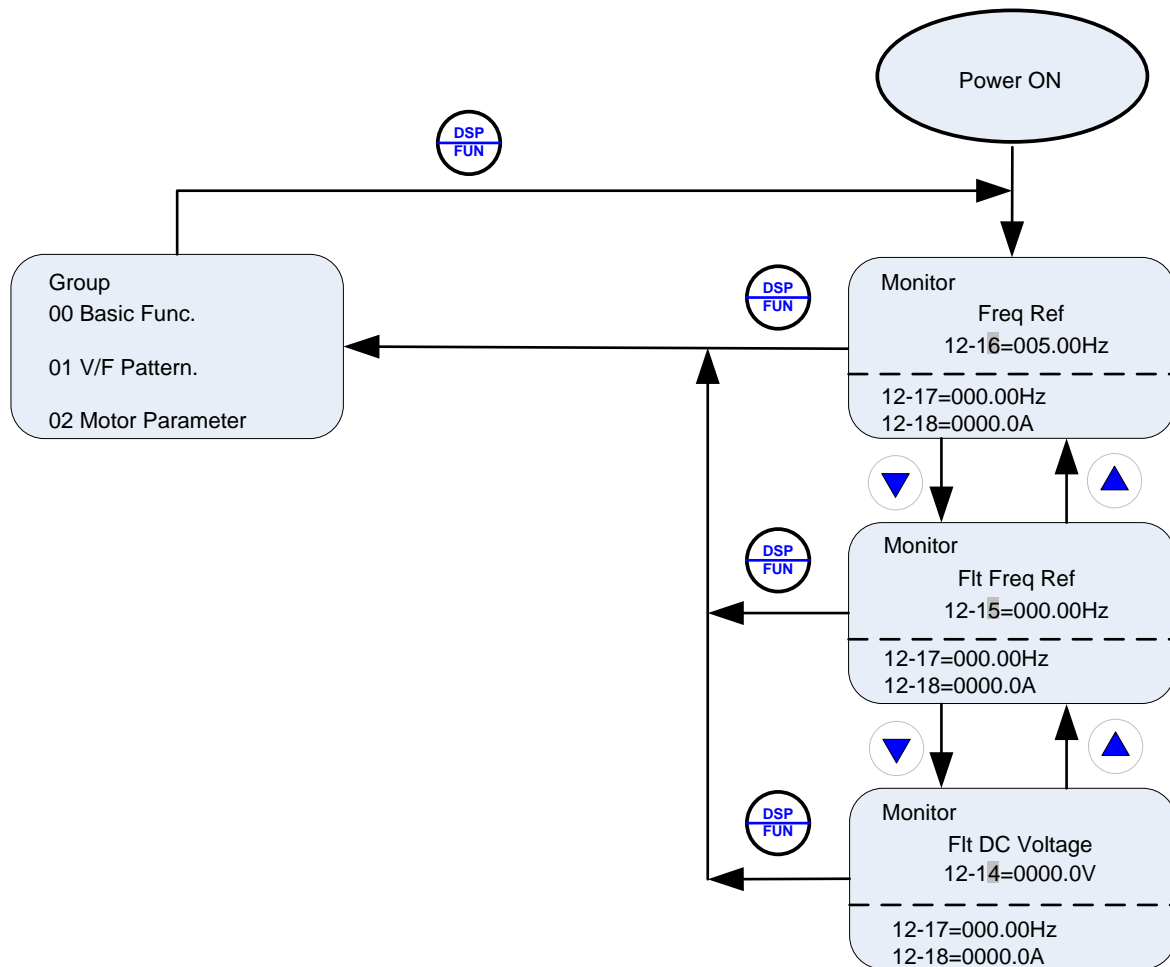

Fig 4.1.2.2 Monitor Mode

Notes:

- To scroll through the available monitor parameter list, press and hold the ▲ (up) or ▼ (down) key.

Programming Mode

In programming mode inverter parameters can be read or changed. See Fig 4.1.2.3 for keypad navigation.

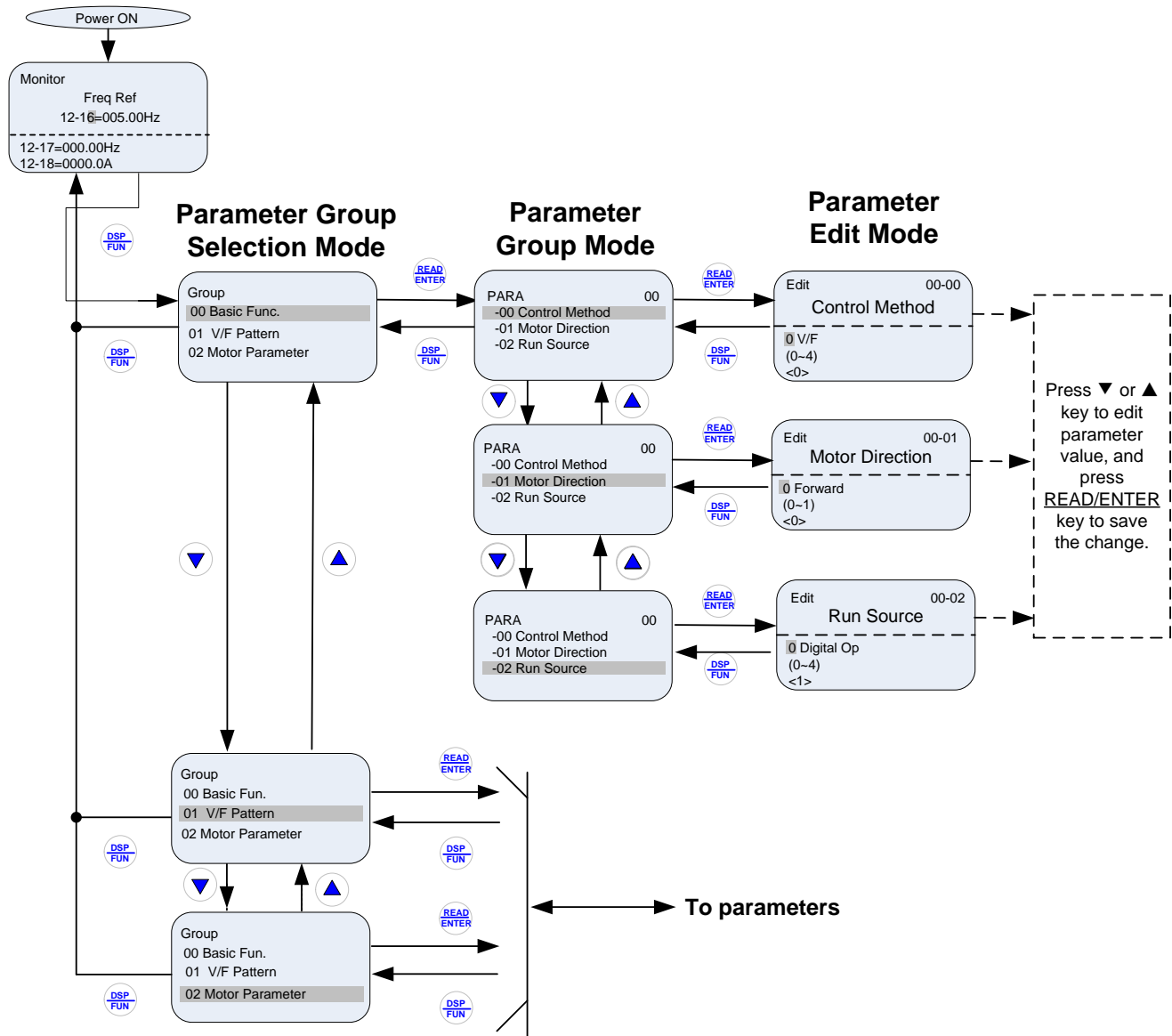

Fig 4.1.2.3 Programming Mode

Notes:

- The parameters values can be changed from the Edit screen with the up, down and < / RESET shift key.
- To save a parameter press the READ/ENTER key.
- Refer to section 4.3 for parameter details.
- Press the ▲ (up) or ▼ (down) key to scroll parameter groups or parameter list.

Auto-tuning Mode (Sensorless Vector Only)

In the auto-tuning mode motor parameters can be calculated and set automatically based on the selected control mode. See Fig 4.1.2.4 for keypad navigation.

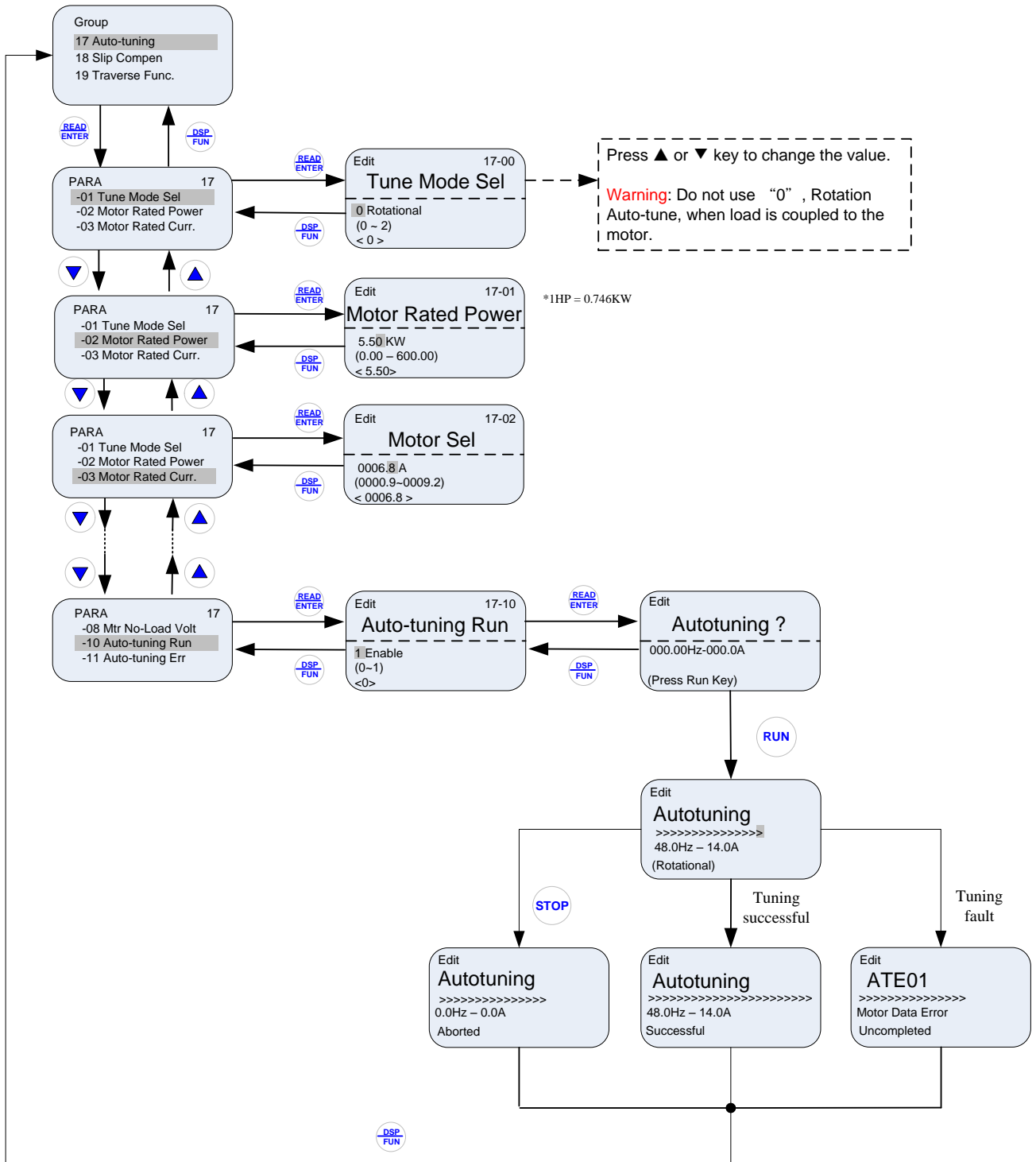

Fig 4.1.2.4 Auto-tuning Mode

Notes:

- Set correct motor parameters by referring to motor nameplate.
- Refer to section 4.3 for parameter details.

Notes:

1. Use the up and down keys to scroll through the auto-tuning parameter list. Depending on the selected control mode in parameter 00-00, some of the auto-tuning parameters will not be accessible. (Refer to the Auto-tuning Group 17 parameters).
2. After entering the motor nameplate rated output power (17-01), rated current (17-02), rated voltage (17-03), rated frequency (17-04), rated speed (17-05) and number of motor poles (17-06), select the automatic tuning mode and press the RUN key to perform the auto-tuning operation. When auto-tuning is successful the calculated motor parameters will be saved into parameter group 02 (motor parameters).
3. (a) "Rotational" will be displayed during rotational auto-tuning (17-00=0) and the motor will rotate during auto-tuning. Ensure that it is safe to operate the motor before pressing the RUN key.
(b) "Stationary" will be displayed during stationary auto-tuning (17-00=1); the motor shaft does not rotate.
(c) The RUN LED (in the upper left corner of the RUN key) will be lit during auto-tuning.
(d) The LCD display shows ">>>" or "Atund" during the auto-tuning process.
4. Press the STOP key on the keypad to abort the auto-tuning operation.
5. In case of an auto-tuning fault, a fault message and the uncompleted message are displayed on the keypad. The RUN LED will be flashing and the motor will coast to stop. (Refer to section 10.4 for the Auto-tuning Faults.) The auto-tuning fault can be cleared by pressing the RESET key after which the keypad displays the auto-tuning mode again.

All motor parameters (group 02 and group 17 parameters) will revert back to their factory settings if a fault occurs. The motor data must be re-entered before starting the auto-tuning function again. The keypad shows ">>>" during an auto-tuning fault.
6. Upon successful completion of an auto-tune, the RUN LED will turn off. Press the DSP/FUN key to return to the main menu to select the next operation. The auto-tuning procedure takes approximately 50 seconds.

4.2 Parameters

| Parameter group | Name |
|-----------------|--|
| Group 00 | Basic Parameters |
| Group 01 | V/F Control Parameters |
| Group 02 | IM Motor Parameters |
| Group 03 | External Digital Input and Output Parameters |
| Group 04 | External Analog Input and Output Parameters |
| Group 05 | Multi-Speed Parameters |
| Group 06 | Automatic Program Operation Parameters |
| Group 07 | Start /Stop Parameters |
| Group 08 | Protection Parameters |
| Group 09 | Communication Parameters |
| Group 10 | PID Parameters |
| Group 11 | Auxiliary Parameters |
| Group 12 | Monitoring Parameters |
| Group 13 | Maintenance Parameters |
| Group 14 | PLC Parameters |
| Group 15 | PLC Monitoring Parameters |
| Group 16 | LCD Parameters |
| Group 17 | Automatic Tuning Parameters |
| Group 18 | Slip Compensation Parameters |
| Group 19 | Wobble Frequency Parameters |
| Group 20 | Speed Control Parameters |
| Group 21 | Torque And Position Control Parameters |
| Group 22 | PM Motor Parameters |
| Group 23 | Pump, HVAC and Compressor |
| Group 24 | Option Card Parameters |

| Group 00: Basic Parameters | | | | | | | | |
|----------------------------|--|--|---------|------|--------------|-----|--------|-----------|
| Code | Parameter Name | Setting Range | Default | Unit | Control Mode | | | Attribute |
| | | | | | V/F | SLV | PM SLV | |
| 00-00 | Control Mode Selection | 0: V/F | 0 | - | O | O | O | *3 |
| | | 2: SLV | | | | | | |
| | | 5: PM SLV | | | | | | |
| 00-01 | Motor's Rotation Direction | 0: Forward | 0 | - | O | O | O | *1 |
| | | 1: Reverse | | | | | | |
| 00-02 | Main Run Command Source Selection | 0: Keypad | 0 | - | O | O | O | |
| | | 1: External Terminal (Control Circuit) | | | | | | |
| | | 2: Communication Control (RS-485) | | | | | | |
| | | 3: PLC | | | | | | |
| 00-03 | Alternative Run Command Source Selection | 0: Keypad | 2 | - | O | O | O | |
| | | 1: External Terminal (Control Circuit) | | | | | | |
| | | 2: Communication Control (RS-485) | | | | | | |
| | | 3: PLC | | | | | | |
| 00-04 | Language Selection | 0: English | 0 | - | O | O | O | |
| | | 1: Simple Chinese | | | | | | |
| | | 2: Traditional Chinese | | | | | | |
| | | | | | | | | |
| 00-05 | Main Frequency Command Source Selection | 0: Keypad | 0 | - | O | O | O | |
| | | 1: External Terminal (Analog AI1) | | | | | | |
| | | 2: Terminal Command UP/ DOWN | | | | | | |
| | | 3: Communication Control (RS-485) | | | | | | |
| | | 6: RTC | | | | | | |
| 7: AI2 Auxiliary Frequency | | | | | | | | |
| 00-06 | Alternative Frequency Command Source Selection | 0: Keypad | 3 | - | O | O | O | |
| | | 1: External Terminal (Analog AI1) | | | | | | |
| | | 2: Terminal Command UP/ DOWN | | | | | | |
| | | 3: Communication Control (RS-485) | | | | | | |
| | | 6: RTC | | | | | | |
| 7: AI2 Auxiliary Frequency | | | | | | | | |
| 00-07 | Main and Alternative Frequency Command Modes | 0: Main Frequency | 0 | - | O | O | O | |
| | | 1: Main Frequency + Alternative Frequency | | | | | | |
| 00-08 | Communication Frequency Command Range | 0.00~400.00 | 0.00 | Hz | O | O | O | |
| 00-09 | Communication Frequency Command Memory Selection | 0: Do not save when power is off. | 0 | - | O | O | O | |
| | | 1: Save when power is off. | | | | | | |
| 00-11 | Selection of PID Lower Limit Frequency | 0: PID is bound to lower limit frequency when inverter sleeps. | 0 | - | O | O | O | |
| | | 1: PID is bound to 0Hz when inverter sleeps. | | | | | | |
| 00-12 | Upper Limit Frequency | 0.1~109.0 | 100.0 | % | O | O | O | |
| 00-13 | Lower Limit Frequency | 0.0~109.0 | 0.0 | % | O | O | O | |
| 00-14 | Acceleration Time 1 | 0.1~6000.0 | - | s | O | O | O | *1 |
| 00-15 | Deceleration Time 1 | 0.1~6000.0 | - | s | O | O | O | *1 |
| 00-16 | Acceleration Time 2 | 0.1~6000.0 | - | s | O | O | O | *1 |
| 00-17 | Deceleration Time 2 | 0.1~6000.0 | - | s | O | O | O | *1 |
| 00-18 | Jog Frequency | 0.00~400.00 | 6.00 | Hz | O | O | O | *1 |
| 00-19 | Jog Acceleration Time | 0.1~0600.0 | - | s | O | O | O | *1 |

| Group 00: Basic Parameters | | | | | | | | |
|----------------------------|--|--|---------|------|--------------|-----|--------|-----------|
| Code | Parameter Name | Setting Range | Default | Unit | Control Mode | | | Attribute |
| | | | | | V/F | SLV | PM SLV | |
| 00-20 | Jog Deceleration Time | 0.1~0600.0 | - | s | O | O | O | *1 |
| 00-21 | Acceleration Time 3 | 0.1~6000.0 | - | s | O | O | O | *1 |
| 00-22 | Deceleration Time 3 | 0.1~6000.0 | - | s | O | O | O | *1 |
| 00-23 | Acceleration Time 4 | 0.1~6000.0 | - | s | O | O | O | *1 |
| 00-24 | Deceleration Time 4 | 0.1~6000.0 | - | s | O | O | O | *1 |
| 00-25 | Switch-Over Frequency of Acc/Dec Time 1 and Time 4 | 0.0~400.0 | 0.0 | Hz | O | O | O | |
| 00-26 | Emergency Stop Time | 0.1~6000.0 | 5.0 | s | O | O | O | |
| 00-28 | Command Characteristic Selection of Master Frequency | 0: Positive Characteristic (0~10V/4~20mA is corresponding to 0~100%) | 0 | - | O | O | O | |
| | | 1: Negative Characteristic (0~10V/4~20mA is corresponding to 100~0%) | | | | | | |
| 00-32 | Application Selection Presets | 0: Default Value | 0 | - | O | O | O | |
| | | 1: Water Supply Pump | | | | | | |
| | | 2: Reserved | | | | | | |
| | | 2: Exhaust fan | | | | | | |
| | | 3: HVAC | | | | | | |
| | | 4: Compressor | | | | | | |
| | | 5: Reserved | | | | | | |
| | | 6: Reserved | | | | | | |
| 00-33 | Modified Parameters (only for LCD) | 0: Enable | 0 | - | O | O | O | |
| | | 1: Disable | | | | | | |
| 00-41 | User Parameter 0 | Set 13-06 = 1, and enable user parameter. Setting Range: 01-00 ~24-06 (only used in LCD keypad) | - | | O | O | O | |
| 00-42 | User Parameter 1 | | - | | O | O | O | |
| 00-43 | User Parameter 2 | | - | | O | O | O | |
| 00-44 | User Parameter 3 | | - | | O | O | O | |
| 00-45 | User Parameter 4 | | - | | O | O | O | |
| 00-46 | User Parameter 5 | | - | | O | O | O | |
| 00-47 | User Parameter 6 | | - | | O | O | O | |
| 00-48 | User Parameter 7 | | - | | O | O | O | |
| 00-49 | User Parameter 8 | | - | | O | O | O | |
| 00-50 | User Parameter 9 | | - | | O | O | O | |
| 00-51 | User Parameter 10 | | - | | O | O | O | |
| 00-52 | User Parameter 11 | | - | | O | O | O | |
| 00-53 | User Parameter 12 | | - | | O | O | O | |
| 00-54 | User Parameter 13 | | - | | O | O | O | |
| 00-55 | User Parameter 14 | | - | | O | O | O | |
| 00-56 | User Parameter 15 | | - | | O | O | O | |

*note1:

Default value is 1 in software V1.1 or the previous (external control); Default value is 0 in software V1.2 or the following (keypad).

| Group 01: V/F Control Parameters | | | | | | | | |
|----------------------------------|---------------------------------------|-------------------------------|---------|------|--------------|-----|--------|-----------|
| Code | Parameter Name | Setting Range | Default | Unit | Control Mode | | | Attribute |
| | | | | | V/F | SLV | PM SLV | |
| 01-00 | V/F Curve Selection | 0~FF | 6 | - | O | X | X | *3 |
| 01-02 | Maximum Output Frequency | 20.0~400.0 | 60.0 | Hz | O | O | O | |
| 01-03 | Maximum Output Voltage | 230V: 0.1~255.0 | 230.0 | V | O | X | X | |
| | | 460V: 0.2~510.0 | 460.0 | | | | | |
| 01-04 | Middle Output Frequency 2 | 0.0~400.0 | 0.0 | Hz | O | X | X | |
| 01-05 | Middle Output Voltage 2 | 230V: 0.0~255.0 | 0.0 | V | O | X | X | |
| | | 460V: 0.0~510.0 | | | | | | |
| 01-06 | Middle Output Frequency 1 | 0.0~400.0 | 30 | Hz | O | X | X | |
| 01-07 | Middle Output Voltage 1 | 230V: 0.0~255.0 | 40.2 | V | O | X | X | |
| | | 460V: 0.0~510.0 | 80.4 | | | | | |
| 01-08 | Minimum Output Frequency | 0.0~400.0 | 1.5 | Hz | O | O | O | |
| 01-09 | Minimum Output Voltage | 230V: 0.0~255.0 | 6.9 | V | O | X | X | |
| | | 460V: 0.0~510.0 | 13.8 | | | | | |
| 01-10 | Torque Compensation Gain | 0.0~2.0 | 0.5 | - | O | X | X | *1 |
| 01-11 | Selection of Torque Compensation Mode | 0: Torque Compensation Mode 0 | 0 | - | O | X | X | |
| | | 1: Torque Compensation Mode 1 | | | | | | |
| 01-12 | Base Frequency | 10.0~400.0 | 60.0 | Hz | O | O | O | |
| 01-13 | Base Output Voltage | 230V: 0.0~255.0 | 230.0 | V | O | X | X | |
| | | 460V: 0.0~510.0 | 460.0 | | | | | |
| 01-14 | Input Voltage Setting | 230V: 155.0~255.0 | 230.0 | V | O | O | O | |
| | | 460V: 310.0~510.0 | 460.0 | | | | | |
| 01-15 | Torque Compensation Time | 0~10000 | 200 | ms | O | X | X | |

| Group 02: IM Motor Parameters | | | | | | | | |
|-------------------------------|-------------------------------|--|---------|------|--------------|-----|--------|-----------|
| Code | Parameter Name | Setting Range | Default | Unit | Control Mode | | | Attribute |
| | | | | | V/F | SLV | PM SLV | |
| 02-00 | No-Load Current | 0.01~600.00 | KVA | A | O | X | X | |
| 02-01 | Rated Current | V/F mode is 10%~200% of inverter's rated current; SLV mode is 25%~200% of inverter's rated current. | KVA | A | O | O | X | |
| 02-03 | Rated Rotation Speed (RPM) | 0~60000 | KVA | Rpm | O | O | X | |
| 02-04 | Rated Voltage | 230V: 50.0~240.0 | 230.0 | V | O | O | X | |
| | | 460V: 100.0~480.0 | 460.0 | | | | | |
| 02-05 | Rated Power | 0.01~600.00 | KVA | kW | O | O | X | |
| 02-06 | Rated Frequency | 10.0~400.0 | 60.0 | Hz | O | O | X | |
| 02-07 | Poles | 2~16 (Even) | 4 | - | O | O | X | |
| 02-09 | Excitation Current | 15.0~70.0 | KVA | % | X | O | X | |
| 02-10 | Core Saturation Coefficient 1 | 1~100 | KVA | % | X | O | X | |
| 02-11 | Core Saturation Coefficient 2 | 1~100 | KVA | % | X | O | X | |
| 02-12 | Core Saturation Coefficient 3 | 80~300 | KVA | % | X | O | X | |
| 02-13 | Core Loss | 0.0~15.0 | KVA | % | O | X | X | |
| 02-15 | Resistance between Wires (R1) | 0.001~60.000 | KVA | Ω | O | O | X | |
| 02-19 | No-Load Voltage | 230V: 50~240 | KVA | V | X | O | X | |
| | | 460V: 100~480 | | | | | | |
| 02-33 | Leakage Inductance Ratio | 0.1~15.0 | KVA | % | X | O | X | |

Group 02: IM Motor Parameters

| Code | Parameter Name | Setting Range | Default | Unit | Control Mode | | | Attribute |
|-------|----------------|---------------|---------|------|--------------|-----|--------|-----------|
| | | | | | V/F | SLV | PM SLV | |
| 02-34 | Slip Frequency | 0.10~20.00 | KVA | Hz | X | O | X | |

Group 03: External Digital Input and Output Parameters

| Code | Parameter Name | Setting Range | Default | Unit | Control Mode | | | Attribute | |
|--|---|---|---------|------|--------------|-----|--------|-----------|--|
| | | | | | V/F | SLV | PM SLV | | |
| 03-00 | Multi-function Terminal Function Setting-S1 | 0: 2-Wire Sequence (ON: Forward Run Command) | 0 | | | O | O | O | |
| | | 1: 2-Wire Sequence (ON: Reverse Run Command) | | | | | | | |
| 03-01 | Multi-function Terminal Function Setting-S2 | 2: Multi-Speed Setting Command 1 | 1 | | | O | O | O | |
| | | 3: Multi-Speed Setting Command 2 | | | | | | | |
| | | 4: Multi-Speed Setting Command 3 | | | | | | | |
| 03-02 | Multi-function Terminal Function Setting-S3 | 5: Multi-Speed Setting Command 4 | 2 | | - | O | O | O | |
| | | 6: Forward Jog Run Command | | | | | | | |
| 03-03 | Multi-function Terminal Function Setting-S4 | 7: Reverse Jog Run Command | 3 | | | O | O | O | |
| | | 8: UP Frequency Increasing Command | | | | | | | |
| 03-04 | Multi-function Terminal Function Setting-S5 | 9: DOWN Frequency Decreasing Command | 4 | | | O | O | O | |
| | | 10: Acceleration/ Deceleration Setting Command 1 | | | | | | | |
| | | 11: Inhibit Acceleration/ Deceleration Command | | | | | | | |
| 03-05 | Multi-function Terminal Function Setting-S6 | 12: Main/Alternative Run command Switching | 17 | | - | O | O | O | |
| | | 13: Main/Alternative Frequency Command Switching | | | | | | | |
| | | 14: Emergency Stop (Decelerate to Zero and Stop) | | | | | | | |
| | | 15: External Baseblock Command (Rotation freely to Stop) | | | | | | | |
| | | 16: PID Control Disable | | | | | | | |
| | | 17: Fault Reset (RESET) | | | | | | | |
| | | 18: Reserved | | | | | | | |
| | | 19: Speed Search 1(from the maximum frequency) | | | | | | | |
| | | 20: Manual Energy Saving Function | | | | | | | |
| | | 21: PID Integral Reset | | | | | | | |
| | | 22~23: Reserved | | | | | | | |
| | | 24: PLC Input | | | | | | | |
| | | 25: External Fault | | | | | | | |
| | | 26: 3-Wire Sequence (Forward/ Reverse Command) | | | | | | | |
| | | 27: Local/ Remote Selection | | | | | | | |
| 28: Remote Mode Selection | | | | | | | | | |
| 29: Jog Frequency Selection | | | | | | | | | |
| 30: Acceleration/ Deceleration Setting Command 2 | | | | | | | | | |
| 31: Inverter Overheating Warning | | | | | | | | | |

Group 03: External Digital Input and Output Parameters

| Code | Parameter Name | Setting Range | Default | Unit | Control Mode | | | Attribute |
|-------|--|---|---------|------|--------------|-----|--------|-----------|
| | | | | | V/F | SLV | PM SLV | |
| | | 32: Reserved | | - | - | - | - | |
| | | 33: DC Braking | | - | O | X | X | |
| | | 34: Speed Search 2 (from Frequency Command) | | - | O | X | O | |
| | | 35: Timing Function Input | | - | O | O | O | |
| | | 36: PID Soft Start Disable | | - | O | O | O | |
| | | 37~40: Reserved | | - | - | - | - | |
| | | 41: PID Sleep | | - | O | O | O | |
| | | 42~46: Reserved | | - | - | - | - | |
| | | 47: Fire Mode (Forced to Run Mode) | | - | O | O | O | |
| | | 48: KEB Acceleration | | - | O | X | X | |
| | | 49: Parameters Writing Allowable | | - | O | O | O | |
| | | 50: Unattended Start Protection (USP) | | - | O | O | O | |
| | | 51~52: Reserved | | - | - | - | - | |
| | | 53: 2-Wire Self Holding Mode (Stop Command) | | | | | | |
| | | 54: Switch PID1 and PID2 | | | | | | |
| | | 55: RTC Timer Switch | | - | O | O | O | |
| | | 56: RTC Offset Switch | | | | | | |
| | | 57: Forced Frequency Run | | | | | | |
| | | 58: Run Permissive Function | | | | | | |
| 03-08 | (S1~S6) DI Scan Time | 0: Scan Time 4ms 1: Scan Time 8ms | 1 | - | O | O | O | |
| 03-09 | Multi-Function Terminal (S1-S4 Type Selection) | xxx0b:S1 A Contact xxx1b:S1 B Contact xx0xb:S2 A Contact xx1xb:S2 B Contact x0xxb:S3 A Contact x1xxb:S3 B Contact 0xxxb:S4 A Contact 1xxxb:S4 B Contact | 0000b | - | O | O | O | |
| 03-10 | Multi-Function Terminal (S5-S6 Type Selection) | xxx0b:S5 A Contact xxx1b:S5 B Contact xx0xb:S6 A Contact xx1xb:S6 B Contact x0xxb: Reserved x1xxb: Reserved 0xxxb: Reserved 1xxxb: Reserved | 0000b | - | O | O | O | |
| 03-11 | Relay (R1A-R1C) Output | 0: During Running 1: Fault Contact Output 2: Frequency Agree | 0 | - | O | O | O | |
| 03-12 | Relay (R2A-R2C) Output | 3: Setting Frequency Agree (03-13 ± 03-14) 4: Frequency Detection 1 (> 03-13, Hysteresis interval 03-14) 5: Frequency Detection 2 (< 03-13, Hysteresis interval 03-14) 6: Automatic Restart | 1 | - | O | O | O | |

Group 03: External Digital Input and Output Parameters

| Code | Parameter Name | Setting Range | Default | Unit | Control Mode | | | Attribute |
|-------|---|---|---------|------|--------------|-----|--------|-----------|
| | | | | | V/F | SLV | PM SLV | |
| | | 7~8: Reserved | | | - | - | - | |
| | | 9: Baseblock | | | O | O | O | |
| | | 10~11: Reserved | | | - | - | - | |
| | | 12: Over-Torque Detection | | | O | O | O | |
| | | 13: Current Agree | | | | | | |
| | | 14~17: Reserved | | | - | - | - | |
| | | 18: PLC Status | | | | | | |
| | | 19: PLC Control Contact | | | | | | |
| | | 20: Zero Speed | | | | | | |
| | | 21: Inverter Ready | | | | | | |
| | | 22: Undervoltage Detection | | | O | O | O | |
| | | 23: Source of Operation Command | | | | | | |
| | | 24: Source of Frequency Command | | | | | | |
| | | 25: Low Torque Detection | | | | | | |
| | | 26: Frequency Reference Missing | | | | | | |
| | | 27: Timing Function Output | | | | | | |
| | | 28~31: Reserved | | | - | - | - | |
| | | 32: Communication Control Contacts | | | | | | |
| | | 33: RTC Timer 1 | | | | | | |
| | | 34: RTC Timer 2 | | | O | O | O | |
| | | 35: RTC Timer 3 | | | | | | |
| | | 36: RTC Timer 4 | | | | | | |
| | | 37: PID Feedback Loss | | | | | | |
| | | 38: Brake Release | | | X | O | X | |
| 03-13 | Frequency Detection Level | 0.0~400.0 | 0.0 | Hz | O | O | O | |
| 03-14 | Frequency Detection Width | 0.1~25.5 | 2.0 | Hz | O | O | O | |
| 03-15 | Current Agree Level | 0.1~999.9 | 0.1 | A | O | O | O | |
| 03-16 | Delay Time of Current Agree Function | 0.1~10.0 | 0.1 | s | X | O | X | |
| 03-19 | Relay(R1A-R3C)Type | xxx0b: R1 A Contact xxx1b: R1 B Contact xx0xb: R2 A Contact xx1xb: R2 B Contact x0xxb: R3 A Contact x1xxb: R3 B Contact | 0000b | - | O | O | O | |
| 03-27 | UP/DOWN Frequency Hold/Adjust Selection | 0: Hold Last Set Frequency when Stopped 1: Set Frequency to 0 when Stopped 2: Allow Speed Changes from Last Set Frequency when Stopped 3: Refresh frequency at acceleration. | 0 | - | O | O | O | |
| 03-30 | Pulse Input Selection | 0: Common Pulse Input 1: PWM (Pulse Width Modulation) | 0 | - | O | O | O | |
| 03-31 | Pulse Input Scaling | 50~32000 | 1000 | Hz | O | O | O | *1 |
| 03-32 | Pulse Input Gain | 0.0~1000.0 | 100 | % | O | O | O | *1 |
| 03-33 | Pulse Input Bias | -100.0~100.0 | 0.0 | % | O | O | O | *1 |
| 03-34 | Pulse Input Filter Time | 0.00~2.00 | 0.1 | Sec | O | O | O | *1 |
| 03-37 | Timer ON Delay (DI/DO) | 0.0~6000.0 | 0.0 | s | O | O | O | |
| 03-38 | Timer OFF Delay (DI/DO) | 0.0~6000.0 | 0.0 | s | O | O | O | |
| 03-39 | Relay (R3A-R3C) Output | Setting range and definition are the | 20 | - | O | O | O | |

Group 03: External Digital Input and Output Parameters

| Code | Parameter Name | Setting Range | Default | Unit | Control Mode | | | Attribute |
|-------|---|-------------------------------------|---------|------|--------------|-----|--------|-----------|
| | | | | | V/F | SLV | PM SLV | |
| | | same as those of 03-11 and 03-12. | | | | | | |
| 03-40 | Up/down Frequency Width Setting | 0.00~5.00 | 0.00 | Hz | O | O | O | |
| 03-41 | Torque Detection Level | 0~300 | 10 | % | X | O | X | |
| 03-42 | Delay Time of Braking Action | 0.00~65.00 | 0.00 | s | X | O | X | |
| 03-43 | UP/DOWN Acceleration/ Deceleration Selection | 0: Acceleration/Deceleration Time 1 | 0 | - | O | O | O | |
| | | 1: Acceleration/Deceleration Time 2 | | | | | | |

Group 04: External Analog Input and Output Parameters

| Code | Parameter Name | Setting Range | Default | Unit | Control Mode | | | Attribute |
|-------------------------|------------------------|---|---------|------|--------------|-----|--------|-----------|
| | | | | | V/F | SLV | PM SLV | |
| 04-00 | AI2 Source Selection | 0: AI2: 0~10V | 1 | - | O | O | O | |
| | | 1: AI2: 4~20mA | | | | | | |
| 04-01 | AI1 Signal Filter Time | 0.00~2.00 | 0.03 | s | O | O | O | |
| 04-02 | AI1 Gain | 0.0~1000.0 | 100.0 | % | O | O | O | *1 |
| 04-03 | AI1 Bias | -100.0~100.0 | 0 | % | O | O | O | *1 |
| 04-05 | AI2 Function Setting | 0: Auxiliary Frequency | 0 | - | O | O | O | |
| | | 1: Frequency Reference Gain | | | O | O | O | |
| | | 2: Frequency Reference Bias | | | O | O | O | |
| | | 3: Output Voltage Bias | | | O | X | O | |
| | | 4: Coefficient of Acceleration and Deceleration Reduction | | | O | O | O | |
| | | 5: DC Braking Current | | | O | O | X | |
| | | 6: Over-Torque Detection Level | | | O | O | O | |
| | | 7: Stall Prevention Level During Running | | | O | X | X | |
| | | 8: Frequency Lower Limit | | | O | O | O | |
| | | 9: Jump Frequency 4 | | | O | O | O | |
| | | 10: Added to AI1 | | | O | O | O | |
| | | 11: Positive Torque Limit | | | X | O | O | |
| | | 12: Negative Torque Limit | | | X | O | O | |
| | | 13: Regenerative Torque Limit | | | X | O | O | |
| | | 14: Positive / Negative Torque Limit | | | X | O | O | |
| | | 15: Reserved | | | - | - | - | |
| 16: Torque Compensation | X | O | X | | | | | |
| 04-06 | AI2 Signal Filter Time | 0.00~2.00 | 0.03 | s | O | O | O | |
| 04-07 | AI2 Gain | 0.0~1000.0 | 100.0 | % | O | O | O | *1 |
| 04-08 | AI2 Bias | -100.0~100.0 | 0 | % | O | O | O | *1 |
| 04-11 | AO1 Function Setting | 0: Output Frequency | 0 | - | O | O | O | |
| | | 1: Frequency Command | | | O | O | O | |
| | | 2: Output Voltage | | | O | O | O | |
| | | 3: DC Voltage | | | O | O | O | |
| | | 4: Output Current | | | O | O | O | |

Group 04: External Analog Input and Output Parameters

| Code | Parameter Name | Setting Range | Default | Unit | Control Mode | | | Attribute |
|-------|-------------------------------|--|---------|------|----------------------------------|----------------------------------|-----------------------|-----------|
| | | | | | V/F | SLV | PM SLV | |
| | | 5: Output Power | | | <input type="radio"/> | <input type="radio"/> | <input type="radio"/> | |
| | | 6: Motor Speed | | | <input type="radio"/> | <input type="radio"/> | <input type="radio"/> | |
| | | 7: Output Power Factor | | | <input type="radio"/> | <input type="radio"/> | <input type="radio"/> | |
| | | 8: AI1 Input | | | <input type="radio"/> | <input type="radio"/> | <input type="radio"/> | |
| | | 9: AI2 Input | | | <input type="radio"/> | <input type="radio"/> | <input type="radio"/> | |
| | | 10: Torque Command | | | <input checked="" type="radio"/> | <input type="radio"/> | <input type="radio"/> | |
| | | 11: q-axis Current | | | <input checked="" type="radio"/> | <input type="radio"/> | <input type="radio"/> | |
| | | 12: d-axis Current | | | <input checked="" type="radio"/> | <input type="radio"/> | <input type="radio"/> | |
| | | 13: Speed deviation | | | <input checked="" type="radio"/> | <input checked="" type="radio"/> | <input type="radio"/> | |
| | | 14: Reserved | | | - | - | - | |
| | | 15: ASR Output | | | <input checked="" type="radio"/> | <input checked="" type="radio"/> | <input type="radio"/> | |
| | | 16: Reserved | | | - | - | - | |
| | | 17: q-axis Voltage | | | <input checked="" type="radio"/> | <input type="radio"/> | <input type="radio"/> | |
| | | 18: d-axis Voltage | | | <input checked="" type="radio"/> | <input type="radio"/> | <input type="radio"/> | |
| | | 19~20: Reserved | | | - | - | - | |
| | | 21: PID Input | | | <input type="radio"/> | <input type="radio"/> | <input type="radio"/> | |
| | | 22: PID Output | | | <input type="radio"/> | <input type="radio"/> | <input type="radio"/> | |
| | | 23: PID Target Value | | | <input type="radio"/> | <input type="radio"/> | <input type="radio"/> | |
| | | 24: PID Feedback Value | | | <input type="radio"/> | <input type="radio"/> | <input type="radio"/> | |
| | | 25: Output Frequency of the Soft Starter | | | <input type="radio"/> | <input type="radio"/> | <input type="radio"/> | |
| | | 26~27: Reserved | | | - | - | - | |
| | | 28: Communication Control | | | <input type="radio"/> | <input type="radio"/> | <input type="radio"/> | |
| 04-12 | AO1 Gain | 0.0~1000.0 | 100.0 | % | <input type="radio"/> | <input type="radio"/> | <input type="radio"/> | *1 |
| 04-13 | AO1 Bias | -100.0~100.0 | 0 | % | <input type="radio"/> | <input type="radio"/> | <input type="radio"/> | *1 |
| 04-16 | AO2 Function Setting | Setting range and definition are the same as 04-11 | 3 | - | <input type="radio"/> | <input type="radio"/> | <input type="radio"/> | |
| 04-17 | AO2 Gain | 0.0~1000.0 | 100.0 | % | <input type="radio"/> | <input type="radio"/> | <input type="radio"/> | *1 |
| 04-18 | AO2 Bias | -100.0~100.0 | 0 | % | <input type="radio"/> | <input type="radio"/> | <input type="radio"/> | *1 |
| 04-19 | AO Output Signal Type | 0: AO1:0~10V AO2:0~10V | 0 | | <input type="radio"/> | <input type="radio"/> | <input type="radio"/> | |
| | | 1: AO1:0~10V AO2:4~20mA | | | | | | |
| | | 2: AO1:4~20mA AO2:0~10V | | | | | | |
| | | 3: AO1:4~20mA AO2: 4~20mA | | | | | | |
| 04-20 | Filter Time of AO Signal Scan | 0.00~0.50 | 0.00 | s | <input type="radio"/> | <input type="radio"/> | <input type="radio"/> | *1 |

| Group 05: Multi-Speed Function Group | | | | | | | | |
|--------------------------------------|--|--|---------|------|--------------|-----|-----------|-----------|
| Code | Parameter Name | Setting Range | Default | Unit | Control Mode | | | Attribute |
| | | | | | V/F | SLV | PM SLV | |
| 05-00 | Acceleration and Deceleration Selection of Multi-Speed | 0: Acceleration and deceleration time are set by 00-14 ~ 00-24 | 0 | - | ○ | ○ | ○ | |
| | | 1: Acceleration and Deceleration Time are set by 05-17 ~ 05-48 | | | | | | |
| 05-01 | Frequency Setting of Speed-Stage 0 | 0.00~400.00 | 5.00 | Hz | ○ | ○ | ○ | *1 |
| 05-02 | Frequency Setting of Speed-Stage 1 | 0.00~400.00 | 5.00 | Hz | ○ | ○ | ○ | |
| 05-03 | Frequency Setting of Speed-Stage 2 | 0.00~400.00 | 10.00 | Hz | ○ | ○ | ○ | |
| 05-04 | Frequency Setting of Speed-Stage 3 | 0.00~400.00 | 20.00 | Hz | ○ | ○ | ○ | |
| 05-05 | Frequency Setting of Speed-Stage 4 | 0.00~400.00 | 30.00 | Hz | ○ | ○ | ○ | |
| 05-06 | Frequency Setting of Speed-Stage 5 | 0.00~400.00 | 40.00 | Hz | ○ | ○ | ○ | |
| 05-07 | Frequency Setting of Speed-Stage 6 | 0.00~400.00 | 50.00 | Hz | ○ | ○ | ○ | |
| 05-08 | Frequency Setting of Speed-Stage 7 | 0.00~400.00 | 50.00 | Hz | ○ | ○ | ○ | |
| 05-09 | Frequency Setting of Speed-Stage 8 | 0.00~400.00 | 5.00 | Hz | ○ | ○ | ○ | |
| 05-10 | Frequency Setting of Speed-Stage 9 | 0.00~400.00 | 5.00 | Hz | ○ | ○ | ○ | |
| 05-11 | Frequency Setting of Speed-Stage 10 | 0.00~400.00 | 5.00 | Hz | ○ | ○ | ○ | |
| 05-12 | Frequency Setting of Speed-Stage 11 | 0.00~400.00 | 5.00 | Hz | ○ | ○ | ○ | |
| 05-13 | Frequency Setting of Speed-Stage 12 | 0.00~400.00 | 5.00 | Hz | ○ | ○ | ○ | |
| 05-14 | Frequency Setting of Speed-Stage 13 | 0.00~400.00 | 5.00 | Hz | ○ | ○ | ○ | |
| 05-15 | Frequency Setting of Speed-Stage 14 | 0.00~400.00 | 5.00 | Hz | ○ | ○ | ○ | |
| 05-16 | Frequency Setting of Speed-Stage 15 | 0.00~400.00 | 5.00 | Hz | ○ | ○ | ○ | |
| 05-17 | Acceleration Time Setting of Multi Speed 0 | 0.1~6000.0 | 10.0 | s | ○ | ○ | ○ | |
| 05-18 | Deceleration Time Setting of Multi Speed 0 | 0.1~6000.0 | 10.0 | s | ○ | ○ | ○ | |
| 05-19 | Acceleration Time Setting of Multi Speed 1 | 0.1~6000.0 | 10.0 | s | ○ | ○ | ○ | |
| 05-20 | Deceleration Time Setting of Multi Speed 1 | 0.1~6000.0 | 10.0 | s | ○ | ○ | ○ | |

| Group 05: Multi-Speed Function Group | | | | | | | | |
|--------------------------------------|---|---------------|---------|------|-----------------------|-----------------------|-----------------------|-----------|
| Code | Parameter Name | Setting Range | Default | Unit | Control Mode | | | Attribute |
| | | | | | V/F | SLV | PM SLV | |
| 05-21 | Acceleration Time Setting of Multi Speed 2 | 0.1~6000.0 | 10.0 | s | <input type="radio"/> | <input type="radio"/> | <input type="radio"/> | |
| 05-22 | Deceleration Time Setting of Multi Speed 2 | 0.1~6000.0 | 10.0 | s | <input type="radio"/> | <input type="radio"/> | <input type="radio"/> | |
| 05-23 | Acceleration Time Setting of Multi Speed 3 | 0.1~6000.0 | 10.0 | s | <input type="radio"/> | <input type="radio"/> | <input type="radio"/> | |
| 05-24 | Deceleration Time Setting of Multi Speed 3 | 0.1~6000.0 | 10.0 | s | <input type="radio"/> | <input type="radio"/> | <input type="radio"/> | |
| 05-25 | Acceleration Time Setting of Multi Speed 4 | 0.1~6000.0 | 10.0 | s | <input type="radio"/> | <input type="radio"/> | <input type="radio"/> | |
| 05-26 | Deceleration Time Setting of Multi Speed 4 | 0.1~6000.0 | 10.0 | s | <input type="radio"/> | <input type="radio"/> | <input type="radio"/> | |
| 05-27 | Acceleration Time Setting of Multi Speed 5 | 0.1~6000.0 | 10.0 | s | <input type="radio"/> | <input type="radio"/> | <input type="radio"/> | |
| 05-28 | Deceleration Time Setting of Multi Speed 5 | 0.1~6000.0 | 10.0 | s | <input type="radio"/> | <input type="radio"/> | <input type="radio"/> | |
| 05-29 | Acceleration Time Setting of Multi Speed 6 | 0.1~6000.0 | 10.0 | s | <input type="radio"/> | <input type="radio"/> | <input type="radio"/> | |
| 05-30 | Deceleration Time Setting of Multi Speed 6 | 0.1~6000.0 | 10.0 | s | <input type="radio"/> | <input type="radio"/> | <input type="radio"/> | |
| 05-31 | Acceleration Time Setting of Multi Speed 7 | 0.1~6000.0 | 10.0 | s | <input type="radio"/> | <input type="radio"/> | <input type="radio"/> | |
| 05-32 | Deceleration Time Setting of Multi Speed 7 | 0.1~6000.0 | 10.0 | s | <input type="radio"/> | <input type="radio"/> | <input type="radio"/> | |
| 05-33 | Acceleration Time Setting of Multi Speed 8 | 0.1~6000.0 | 10.0 | s | <input type="radio"/> | <input type="radio"/> | <input type="radio"/> | |
| 05-34 | Deceleration Time Setting of Multi Speed 8 | 0.1~6000.0 | 10.0 | s | <input type="radio"/> | <input type="radio"/> | <input type="radio"/> | |
| 05-35 | Acceleration Time Setting of Multi Speed 9 | 0.1~6000.0 | 10.0 | s | <input type="radio"/> | <input type="radio"/> | <input type="radio"/> | |
| 05-36 | Deceleration Time Setting of Multi Speed 9 | 0.1~6000.0 | 10.0 | s | <input type="radio"/> | <input type="radio"/> | <input type="radio"/> | |
| 05-37 | Acceleration Time Setting of Multi Speed 10 | 0.1~6000.0 | 10.0 | s | <input type="radio"/> | <input type="radio"/> | <input type="radio"/> | |
| 05-38 | Deceleration Time Setting of Multi Speed 10 | 0.1~6000.0 | 10.0 | s | <input type="radio"/> | <input type="radio"/> | <input type="radio"/> | |
| 05-39 | Acceleration Time Setting of Multi Speed 11 | 0.1~6000.0 | 10.0 | s | <input type="radio"/> | <input type="radio"/> | <input type="radio"/> | |
| 05-40 | Deceleration Time Setting of Multi Speed 11 | 0.1~6000.0 | 10.0 | s | <input type="radio"/> | <input type="radio"/> | <input type="radio"/> | |
| 05-41 | Acceleration Time Setting of Multi Speed 12 | 0.1~6000.0 | 10.0 | s | <input type="radio"/> | <input type="radio"/> | <input type="radio"/> | |
| 05-42 | Deceleration Time Setting of Multi Speed 12 | 0.1~6000.0 | 10.0 | s | <input type="radio"/> | <input type="radio"/> | <input type="radio"/> | |

| Group 05: Multi-Speed Function Group | | | | | | | | |
|--------------------------------------|---|---------------|---------|------|--------------|-----|--------|-----------|
| Code | Parameter Name | Setting Range | Default | Unit | Control Mode | | | Attribute |
| | | | | | V/F | SLV | PM SLV | |
| 05-43 | Acceleration Time Setting of Multi Speed 13 | 0.1~6000.0 | 10.0 | s | O | O | O | |
| 05-44 | Deceleration Time Setting of Multi Speed 13 | 0.1~6000.0 | 10.0 | s | O | O | O | |
| 05-45 | Acceleration Time Setting of Multi Speed 14 | 0.1~6000.0 | 10.0 | s | O | O | O | |
| 05-46 | Deceleration Time Setting of Multi Speed 14 | 0.1~6000.0 | 10.0 | s | O | O | O | |
| 05-47 | Acceleration Time Setting of Multi Speed 15 | 0.1~6000.0 | 10.0 | s | O | O | O | |
| 05-48 | Deceleration Time Setting of Multi Speed 15 | 0.1~6000.0 | 10.0 | s | O | O | O | |

| Group 06: Automatic Program Operation Parameters | | | | | | | | |
|--|------------------------------------|--|---------|------|--------------|-----|--------|-----------|
| Code | Parameter Name | Setting Range | Default | Unit | Control Mode | | | Attribute |
| | | | | | V/F | SLV | PM SLV | |
| 06-00 | Automatic Operation Mode Selection | 0: Disable | 0 | - | O | O | X | |
| | | 1: Execute a single cycle operation mode. Restart speed is based on the previous stopped speed. | | | | | | |
| | | 2: Execute continuous cycle operation mode. Restart speed is based on the previous stopped speed. | | | | | | |
| | | 3: After the completion of a single cycle, the on-going operation speed is based on the speed of the last stage. Restart speed is based on the previous stopped speed. | | | | | | |
| | | 4: Execute a single cycle operation mode. Restart speed will be based on the speed of stage 1. | | | | | | |
| | | 5: Execute continuous cycle operation mode. Restart speed will be based on the speed of stage 1. | | | | | | |
| | | 6: After the completion of a single cycle, the on-going operation speed is based on the speed of the last stage. Restart speed is based on the Speed of Stage1. | | | | | | |
| 06-01 | Frequency Setting of Speed-Stage 1 | 0.00~400.00 | 5.00 | Hz | O | O | O | *1 |

Group 06: Automatic Program Operation Parameters

| Code | Parameter Name | Setting Range | Default | Unit | Control Mode | | | Attribute |
|-------|---|---------------|---------|------|-----------------------|-----------------------|----------------------------------|-----------|
| | | | | | V/F | SLV | PM SLV | |
| 06-02 | Frequency Setting of Speed-Stage 2 | 0.00~400.00 | 10.00 | Hz | <input type="radio"/> | <input type="radio"/> | <input type="radio"/> | *1 |
| 06-03 | Frequency Setting of Speed-Stage 3 | 0.00~400.00 | 20.00 | Hz | <input type="radio"/> | <input type="radio"/> | <input type="radio"/> | *1 |
| 06-04 | Frequency Setting of Speed-Stage 4 | 0.00~400.00 | 30.00 | Hz | <input type="radio"/> | <input type="radio"/> | <input type="radio"/> | *1 |
| 06-05 | Frequency Setting of Speed-Stage 5 | 0.00~400.00 | 40.00 | Hz | <input type="radio"/> | <input type="radio"/> | <input type="radio"/> | *1 |
| 06-06 | Frequency Setting of Speed-Stage 6 | 0.00~400.00 | 50.00 | Hz | <input type="radio"/> | <input type="radio"/> | <input type="radio"/> | *1 |
| 06-07 | Frequency Setting of Speed-Stage 7 | 0.00~400.00 | 50.00 | Hz | <input type="radio"/> | <input type="radio"/> | <input type="radio"/> | *1 |
| 06-08 | Frequency Setting of Speed-Stage 8 | 0.00~400.00 | 5.00 | Hz | <input type="radio"/> | <input type="radio"/> | <input type="radio"/> | *1 |
| 06-09 | Frequency Setting of Speed-Stage 9 | 0.00~400.00 | 5.00 | Hz | <input type="radio"/> | <input type="radio"/> | <input type="radio"/> | *1 |
| 06-10 | Frequency Setting of Speed-Stage 10 | 0.00~400.00 | 5.00 | Hz | <input type="radio"/> | <input type="radio"/> | <input type="radio"/> | *1 |
| 06-11 | Frequency Setting of Speed-Stage 11 | 0.00~400.00 | 5.00 | Hz | <input type="radio"/> | <input type="radio"/> | <input type="radio"/> | *1 |
| 06-12 | Frequency Setting of Speed-Stage 12 | 0.00~400.00 | 5.00 | Hz | <input type="radio"/> | <input type="radio"/> | <input type="radio"/> | *1 |
| 06-13 | Frequency Setting of Speed-Stage 13 | 0.00~400.00 | 5.00 | Hz | <input type="radio"/> | <input type="radio"/> | <input type="radio"/> | *1 |
| 06-14 | Frequency Setting of Speed-Stage 14 | 0.00~400.00 | 5.00 | Hz | <input type="radio"/> | <input type="radio"/> | <input type="radio"/> | *1 |
| 06-15 | Frequency Setting of Speed-Stage 15 | 0.00~400.00 | 5.00 | Hz | <input type="radio"/> | <input type="radio"/> | <input type="radio"/> | *1 |
| 06-16 | Operation Time Setting of Speed-Stage 0 | 0.0~6000.0 | 0.0 | s | <input type="radio"/> | <input type="radio"/> | <input checked="" type="radio"/> | *1 |
| 06-17 | Operation Time Setting of Speed-Stage 1 | 0.0~6000.0 | 0.0 | s | <input type="radio"/> | <input type="radio"/> | <input checked="" type="radio"/> | *1 |
| 06-18 | Operation Time Setting of Speed-Stage 2 | 0.0~6000.0 | 0.0 | s | <input type="radio"/> | <input type="radio"/> | <input checked="" type="radio"/> | *1 |
| 06-19 | Operation Time Setting of Speed-Stage 3 | 0.0~6000.0 | 0.0 | s | <input type="radio"/> | <input type="radio"/> | <input checked="" type="radio"/> | *1 |
| 06-20 | Operation Time Setting of Speed-Stage 4 | 0.0~6000.0 | 0.0 | s | <input type="radio"/> | <input type="radio"/> | <input checked="" type="radio"/> | *1 |
| 06-21 | Operation Time Setting of Speed-Stage 5 | 0.0~6000.0 | 0.0 | s | <input type="radio"/> | <input type="radio"/> | <input checked="" type="radio"/> | *1 |
| 06-22 | Operation Time Setting of Speed-Stage 6 | 0.0~6000.0 | 0.0 | s | <input type="radio"/> | <input type="radio"/> | <input checked="" type="radio"/> | *1 |
| 06-23 | Operation Time Setting of Speed-Stage 7 | 0.0~6000.0 | 0.0 | s | <input type="radio"/> | <input type="radio"/> | <input checked="" type="radio"/> | *1 |

Group 06: Automatic Program Operation Parameters

| Code | Parameter Name | Setting Range | Default | Unit | Control Mode | | | Attribute |
|-------|---|-------------------------------|---------|------|--------------|-----|-----------|-----------|
| | | | | | V/F | SLV | PM SLV | |
| 06-24 | Operation Time Setting of Speed-Stage 8 | 0.0~6000.0 | 0.0 | s | O | O | X | *1 |
| 06-25 | Operation Time Setting of Speed-Stage 9 | 0.0~6000.0 | 0.0 | s | O | O | X | *1 |
| 06-26 | Operation Time Setting of Speed-Stage 10 | 0.0~6000.0 | 0.0 | s | O | O | X | *1 |
| 06-27 | Operation Time Setting of Speed-Stage 11 | 0.0~6000.0 | 0.0 | s | O | O | X | *1 |
| 06-28 | Operation Time Setting of Speed-Stage 12 | 0.0~6000.0 | 0.0 | s | O | O | X | *1 |
| 06-29 | Operation Time Setting of Speed-Stage 13 | 0.0~6000.0 | 0.0 | s | O | O | X | *1 |
| 06-30 | Operation Time Setting of Speed-Stage 14 | 0.0~6000.0 | 0.0 | s | O | O | X | *1 |
| 06-31 | Operation Time Setting of Speed-Stage 15 | 0.0~6000.0 | 0.0 | s | O | O | X | *1 |
| 06-32 | Operation Direction Selection of Speed-Stage 0 | 0: Stop 1: Forward 2: Reverse | 0 | - | O | O | X | |
| 06-33 | Operation Direction Selection of Speed-Stage 1 | 0: Stop 1: Forward 2: Reverse | 0 | - | O | O | X | |
| 06-34 | Operation Direction Selection of Speed-Stage 2 | 0: Stop 1: Forward 2: Reverse | 0 | - | O | O | X | |
| 06-35 | Operation Direction Selection of Speed-Stage 3 | 0: Stop 1: Forward 2: Reverse | 0 | - | O | O | X | |
| 06-36 | Operation Direction Selection of Speed-Stage 4 | 0: Stop 1: Forward 2: Reverse | 0 | - | O | O | X | |
| 06-37 | Operation Direction Selection of Speed-Stage 5 | 0: Stop 1: Forward 2: Reverse | 0 | - | O | O | X | |
| 06-38 | Operation Direction Selection of Speed-Stage 6 | 0: Stop 1: Forward 2: Reverse | 0 | - | O | O | X | |
| 06-39 | Operation Direction Selection of Speed-Stage 7 | 0: Stop 1: Forward 2: Reverse | 0 | - | O | O | X | |
| 06-40 | Operation Direction Selection of Speed-Stage 8 | 0: Stop 1: Forward 2: Reverse | 0 | - | O | O | X | |
| 06-41 | Operation Direction Selection of Speed-Stage 9 | 0: Stop 1: Forward 2: Reverse | 0 | - | O | O | X | |
| 06-42 | Operation Direction Selection of Speed-Stage 10 | 0: Stop 1: Forward 2: Reverse | 0 | - | O | O | X | |
| 06-43 | Operation Direction Selection of Speed-Stage 11 | 0: Stop 1: Forward 2: Reverse | 0 | - | O | O | X | |
| 06-44 | Operation Direction Selection of Speed-Stage 12 | 0: Stop 1: Forward 2: Reverse | 0 | - | O | O | X | |
| 06-45 | Operation Direction Selection of Speed-Stage 13 | 0: Stop 1: Forward 2: Reverse | 0 | - | O | O | X | |

Group 06: Automatic Program Operation Parameters

| Code | Parameter Name | Setting Range | Default | Unit | Control Mode | | | Attribute |
|-------|---|-------------------------------|---------|------|--------------|-----|--------|-----------|
| | | | | | V/F | SLV | PM SLV | |
| 06-46 | Operation Direction Selection of Speed-Stage 14 | 0: Stop 1: Forward 2: Reverse | 0 | - | ○ | ○ | X | |
| 06-47 | Operation Direction Selection of Speed-Stage 15 | 0: Stop 1: Forward 2: Reverse | 0 | - | ○ | ○ | X | |

Group 07: Start /Stop Parameters

| Code | Parameter Name | Setting Range | Default | Unit | Control Mode | | | Attribute |
|-------|--|-----------------------------|---------|------|--------------|-----|--------|-----------|
| | | | | | V/F | SLV | PM SLV | |
| 07-00 | Momentary Power Loss/ Fault Restart Selection | 0: Disable | 0 | - | ○ | ○ | ○ | |
| | | 1: Enable | | | | | | |
| 07-01 | Fault Auto-Restart Time | 0~7200 | 0 | s | ○ | ○ | ○ | |
| 07-02 | Number of Fault Auto-Restart Attempts | 0~10 | 0 | - | ○ | ○ | ○ | |
| 07-04 | Direct Start at Power up | 0:Enable | 1 | - | ○ | ○ | ○ | |
| | | 1:Disable | | | | | | |
| 07-05 | Delay Time of Direct Start | 1.0~300.0 | 1.5 | Sec | ○ | ○ | ○ | |
| 07-06 | DC Injection Braking Starting Frequency | 0.0~10.0 | 0.5 | Hz | ○ | ○ | X | |
| 07-07 | DC Injection Braking Current | 0~100 | 50 | % | ○ | ○ | X | |
| 07-08 | DC Injection Braking Time at Stop | 0.00~10.00 | 0.50 | s | ○ | ○ | X | |
| 07-09 | Stop Mode Selection | 0: Deceleration to Stop | 0 | - | ○ | ○ | ○ | |
| | | 1: Coast to Stop | | | | | | |
| | | 2: DC Braking Stop | | | | | | |
| | | 3: Coast to Stop with Timer | | | | | | |
| 07-13 | Low Voltage Detection Level | 230V: 150~300 | 190 | V | ○ | ○ | ○ | |
| | | 460V: 300~600 | 380 | | | | | |
| 07-14 | Pre-excitation Time | 0.00~10.00 | 2.00 | s | X | ○ | X | |
| 07-15 | Pre-excitation Level | 50~200 | 100 | % | X | ○ | X | |
| 07-16 | DC Injection Braking Time at Start | 0.00~100.00 | 0.00 | s | ○ | ○ | X | |
| 07-18 | Minimum Base block Time | 0.1~5.0 | - | Sec | ○ | ○ | ○ | |
| 07-19 | Bi-Direction-Detection Speed Search Operating Current | 0~100 | 50 | % | ○ | ○ | X | |
| 07-20 | One-Direction-Detection Speed Search Operating Current | 0~100 | 20 | % | ○ | ○ | X | |
| 07-21 | Integral Time of Speed Searching | 0.1~10.0 | 2.0 | Sec | ○ | ○ | X | |
| 07-22 | Delay Time of Speed Searching | 0.0~20.0 | 0.2 | Sec | ○ | ○ | X | |
| 07-23 | Voltage Recovery Time | 0.1~5.0 | 2.0 | Sec | ○ | ○ | X | |
| 07-24 | Bi-Direction-Detection Speed | 0: Disable | 0 | - | ○ | ○ | X | |

| Group 07: Start /Stop Parameters | | | | | | | | |
|----------------------------------|---|--|---------|------|--------------|-----|--------|-----------|
| Code | Parameter Name | Setting Range | Default | Unit | Control Mode | | | Attribute |
| | | | | | V/F | SLV | PM SLV | |
| | Search Selection | 1: Enable | | | | | | |
| 07-25 | Low voltage Detection Time | 0.00~1.00 | 0.00 | Sec | O | O | O | |
| 07-26 | Start Selection after Coast to Stop During SLV mode | 0: Start with Speed Search | 0 | - | X | O | X | |
| | | 1: Normal Start | | | | | | |
| 07-27 | Start Selection after Fault during SLV Mode | 0: Start with Speed Search | 0 | - | X | O | O | |
| | | 1: Normal Start | | | | | | |
| 07-28 | Start Selection after External Base Block | 0: Start with Speed Search | 0 | - | O | O | X | |
| | | 1: Normal Start | | | | | | |
| 07-29 | Run Command Available During DC Braking | 0: Disable (Run Command isn't available until DC Braking is completely done) | 0 | - | O | X | X | |
| | | 1: Enable | | | | | | |

| Group 08: Protection Parameters | | | | | | | | |
|---------------------------------|---|---|---------|------|--------------|-----|--------|-----------|
| Code | Parameter Name | Setting Range | Default | Unit | Control Mode | | | Attribute |
| | | | | | V/F | SLV | PM SLV | |
| 08-00 | Stall Prevention Function | xxx0b: Stall prevention is enabled in acceleration. | 0000b | - | O | O | O | |
| | | xxx1b: Stall prevention is disabled in acceleration. | | | | | | |
| | | xx0xb: Stall prevention is enabled in deceleration. | | | | | | |
| | | xx1xb: Stall prevention is disabled in deceleration. | | | | | | |
| | | x0xxb: Stall prevention is enabled in operation | | | | | | |
| | | x1xxb: Stall prevention is disabled in operation | | | | | | |
| | | 0xxxb: Stall prevention in operation decelerates based on deceleration time 1 | | | | | | |
| | | 1xxxb: Stall prevention in operation decelerates based on deceleration time 2 | | | | | | |
| 08-01 | Stall Prevention Level in Acceleration | 30~200 | 120 | % | O | O | O | |
| 08-02 | Stall Prevention Level in Deceleration | 230V: 330~410 | 385 | V | O | O | O | |
| | | 460V: 660~820 | 770 | | | | | |
| 08-03 | Stall Prevention Level in Operation | 30~200 | 120 | % | O | O | O | |
| 08-05 | Selection for Motor Overload Protection (OL1) | xxx0b: Motor Overload Protection is disabled | 0001b | - | O | O | O | |
| | | xxx1b: Motor Overload Protection is | | | | | | |

| Group 08: Protection Parameters | | | | | | | | |
|---------------------------------|--|---|---------|------|--------------|-----|--------|-----------|
| Code | Parameter Name | Setting Range | Default | Unit | Control Mode | | | Attribute |
| | | | | | V/F | SLV | PM SLV | |
| | | enabled | | | | | | |
| | | xx0xb: Cold Start of Motor Overload | | | | | | |
| | | xx1xb: Hot Start of Motor Overload | | | | | | |
| | | x0xxb: Standard Motor | | | | | | |
| | | x1xxb: Inverter motor | | | | | | |
| | | 0xxxb: Reserved | | | | | | |
| | | 1xxxb: Reserved | | | | | | |
| 08-06 | Start-up Mode of Overload Protection Operation (OL1) | 0: Stop Output after Overload Protection | 0 | - | ○ | ○ | ○ | |
| | | 1: Continuous Operation after Overload Protection. | | | | | | |
| 08-08 | Automatic Voltage Regulation (AVR) | 0: Enable | 0 | - | ○ | ○ | ○ | |
| | | 1: Disable | | | | | | |
| 08-09 | Selection of Input Phase Loss Protection | 0: Disable | 0 | - | ○ | ○ | ○ | |
| | | 1: Enable | | | | | | |
| 08-10 | Selection of Output Phase Loss Protection | 0: Disable | 0 | - | ○ | ○ | ○ | |
| | | 1: Enable | | | | | | |
| 08-13 | Selection of Over-Torque Detection | 0: Over-Torque Detection is Disabled. | 0 | - | ○ | ○ | ○ | |
| | | 1: Start to Detect when Reaching the Set Frequency. | | | | | | |
| | | 2: Start to Detect when the Operation is Begun. | | | | | | |
| 08-14 | Selection of Over-Torque Operation | 0: Deceleration to Stop when Over-Torque is Detected. | 0 | - | ○ | ○ | ○ | |
| | | 1: Display Warning when Over-Torque is Detected. Go on Operation. | | | | | | |
| | | 2: Coast to Stop when Over Torque is Detected | | | | | | |
| 08-15 | Level of Over-Torque Detection | 0~300 | 150 | % | ○ | ○ | ○ | |
| 08-16 | Time of Over-Torque Detection | 0.0~10.0 | 0.1 | Sec | ○ | ○ | ○ | |
| 08-17 | Selection of Low-Torque Detection | 0: Low-Torque Detection is Disabled. | 0 | - | ○ | ○ | ○ | |
| | | 1: Start to Detect when Reaching the Set Frequency. | | | | | | |
| | | 2: Start to Detect when the Operation is Begun. | | | | | | |
| 08-18 | Selection of Low-Torque Operation | 0: Deceleration to Stop when Low-Torque is Detected. | 0 | - | ○ | ○ | ○ | |
| | | 1: Display Warning when Low-Torque is Detected. Go on Operation. | | | | | | |
| | | 2: Coast to Stop when Low-Torque is Detected | | | | | | |
| 08-19 | Level of Low-Torque Detection | 0~300 | 30 | % | ○ | ○ | ○ | |
| 08-20 | Time of Low-Torque Detection | 0.0~10.0 | 0.1 | Sec | ○ | ○ | ○ | |
| 08-21 | Limit of Stall Prevention in Acc | 0~100 | 50 | % | ○ | ○ | ○ | |

| Group 08: Protection Parameters | | | | | | | | |
|---------------------------------|--|---|---------|------|--------------|-----|--------|-----------|
| Code | Parameter Name | Setting Range | Default | Unit | Control Mode | | | Attribute |
| | | | | | V/F | SLV | PM SLV | |
| | over Base Speed | | | | | | | |
| 08-22 | Stall Prevention Detection Time in Operation | 2~100 | 100 | ms | O | O | O | |
| 08-23 | Ground Fault (GF) Selection | 0: Disable | 0 | - | O | O | O | |
| | | 1: Enable | | | | | | |
| 08-24 | External Fault Operation Selection | 0: Deceleration to Stop | 0 | - | O | O | O | |
| | | 1: Coast to Stop | | | | | | |
| | | 2: Continuous Operation | | | | | | |
| 08-25 | Detection selection of External Fault | 0: Immediately Detect when the Power is Supplied. | 0 | - | O | O | O | |
| | | 1: Start to Detect during Operation | | | | | | |
| 08-30 | Run Permissive Operation Selection | 0: Deceleration to Stop | 0 | - | O | O | O | |
| | | 1: Coast to Stop | | | | | | |
| 08-35 | Motor Overheat Operation Selection | 0: Disable | 0 | - | O | O | O | |
| | | 1: Deceleration to Stop | | | | | | |
| | | 2: Coast to Stop | | | | | | |
| 08-36 | PTC Filter Time | 0.00 ~ 5.00 | 0.20 | Sec | O | O | O | |
| 08-37 | Fan Control Function | 0: Start During Operation | 0 | - | O | O | O | |
| | | 1: Immediately Start when Power is Supplier | | | | | | |
| | | 2: Start During High Temperature* | | | | | | |
| 08-38 | Delay Time for Fan Off | 0~600 | 60 | Sec | O | O | O | |
| 08-39 | Delay Time for Motor Overheat Protection | 1~300 | 60 | Sec | O | O | O | |

* Models of inverter ratings above 2040 and 4050 in IP20 enclosure do not have this function.

| Group 09: Communication Parameters | | | | | | | | |
|------------------------------------|-----------------------------------|---|---------|------|--------------|-----|--------|-----------|
| Code | Parameter Name | Setting Range | Default | Unit | Control Mode | | | Attribute |
| | | | | | V/F | SLV | PM SLV | |
| 09-00 | INV Communication Station Address | 1~31 | 1 | - | O | O | O | *2 |
| 09-01 | Communication Mode Selection | 0: MODBUS | 0 | - | O | O | O | |
| | | 1: BACNet | | | | | | |
| | | 2: METASYS | | | | | | |
| | | 3: Multi-Pump | | | | | | |
| | | 4: PROFIBUS (Available when Connect to Profibus Card) | | | | | | |
| 09-02 | Baud Rate Setting (bps) | 0:1200 | 3 | - | O | O | O | *2 |
| | | 1:2400 | | | | | | |
| | | 2:4800 | | | | | | |
| | | 3:9600 | | | | | | |
| | | 4:19200 | | | | | | |

| Group 09: Communication Parameters | | | | | | | | |
|------------------------------------|---|---|---------|------|--------------|-----|--------|-----------|
| Code | Parameter Name | Setting Range | Default | Unit | Control Mode | | | Attribute |
| | | | | | V/F | SLV | PM SLV | |
| | | 5:38400 | | | | | | |
| 09-03 | Stop Bit Selection | 0:1 Stop Bit 1: 2 Stop Bit | 0 | - | O | O | O | *2 |
| 09-04 | Parity Selection | 0: No Parity 1: Even Bit 2: Odd Bit | 0 | - | O | O | O | *2 |
| 09-06 | Communication Error Detection Time | 0.0~25.5 | 0.0 | S | O | O | O | |
| 09-07 | Communication Fault Operation Selection | 0: Deceleration to Stop Based on Deceleration Time 1 when Communication Fault Occurs. 1: Coast to Stop when Communication Fault Occurs. 2: Deceleration to Stop Based on Deceleration Time 2 when Communication Fault Occurs. 3: Keep Operating when Communication Fault Occurs. | 3 | - | O | O | O | |
| 09-08 | Comm. Fault Tolerance Count | 1~20 | 1 | - | O | O | O | |
| 09-09 | Waiting Time | 5~65 | 5 | ms | O | O | O | |
| 09-10 | Device Instance Number | 1 ~ 254 | 1 | - | O | O | O | |

| Group 10: PID Parameters | | | | | | | | |
|--------------------------|-----------------------------------|---|---------|------|--------------|-----|--------|-----------|
| Code | Parameter Name | Setting Range | Default | Unit | Control Mode | | | Attribute |
| | | | | | V/F | SLV | PM SLV | |
| 10-00 | PID Target Value Source Setting | 1: AI1 Terminal 2: AI2 Terminal 3: Reserved 4:10-02/12-38 Setting 5: Reserved 6: Refer to the setting of 00-05 | 4 | - | O | O | O | |
| 10-01 | PID Feedback Value Source Setting | 1:AI1 Terminal 2:AI2 Terminal 3: Reserved | 2 | - | O | O | O | |
| 10-02 | PID Target Value | 0.0~100.0 | 0.0 | % | O | O | O | |
| 10-03 | PID Control Mode | xx0b: PID Disable xxx1b: PID Enable xx0xb: PID Positive Characteristic xx1xb: PID Negative Characteristic x0xxb: PID Error Value of D Control x1xxb: PID Feedback Value of D Control | 0000b | - | O | O | O | |

| Group 10: PID Parameters | | | | | | | | |
|--------------------------|---|--------------------------------------|---------|------|--------------|-----|-----------|-----------|
| Code | Parameter Name | Setting Range | Default | Unit | Control Mode | | | Attribute |
| | | | | | V/F | SLV | PM SLV | |
| | | 0xxb: PID Output | | | | | | |
| | | 1xxb: PID Output + Frequency Command | | | | | | |
| 10-04 | Feedback Gain | 0.01~10.00 | 1.00 | - | O | O | O | *1 |
| 10-05 | Proportional Gain (P) | 0.00~10.00 | 3.00 | - | O | O | O | *1 |
| 10-06 | Integral Time (I) | 0.00~100.00 | 7.00 | s | O | O | O | *1 |
| 10-07 | Differential Time (D) | 0.00~10.00 | 0.00 | s | O | O | O | *1 |
| 10-09 | PID Bias | -100.0~100.0 | 0 | % | O | O | O | *1 |
| 10-10 | PID Primary Delay Time | 0.00~10.00 | 0.00 | s | O | O | O | *1 |
| 10-11 | PID Feedback Loss Detection Selection | 0: Disable | 0 | - | O | O | O | |
| | | 1: Warning | | | | | | |
| | | 2: Fault | | | | | | |
| 10-12 | PID Feedback Loss Detection Level | 0~100 | 0 | % | O | O | O | |
| 10-13 | PID Feedback Loss Detection Time | 0.0~10.0 | 1.0 | s | O | O | O | |
| 10-14 | PID Integral Limit | 0.0~100.0 | 100.0 | % | O | O | O | *1 |
| 10-17 | Start Frequency of PID Sleep | 0.00~180.00 | 30.00 | Hz | O | O | O | |
| 10-18 | Delay Time of PID Sleep | 0.0~255.5 | 0.0 | s | O | O | O | |
| 10-19 | Frequency of PID Waking up | 0.00~180.00 | 0.00 | Hz | O | O | O | |
| 10-20 | Delay Time of PID Waking up | 0.0~255.5 | 0.0 | s | O | O | O | |
| 10-23 | PID Limit | 0.00~100.0 | 100.0 | % | O | O | O | *1 |
| 10-24 | PID Output Gain | 0.0~25.0 | 1.0 | - | O | O | O | |
| 10-25 | PID Reversal Output Selection | 0: Do not Allow Reversal Output | 0 | - | O | O | O | |
| | | 1: Allow Reversal Output | | | | | | |
| 10-26 | PID Target Acceleration/Deceleration Time | 0.0~25.5 | 0.0 | s | O | O | O | |
| 10-27 | PID Feedback Display Bias | -99.99~99.99 | 0.00 | - | O | O | O | |
| 10-28 | PID Feedback Display Gain | 0.00~100.00 | 100.00 | - | O | O | O | |
| 10-29 | PID Sleep Selection | 0: Disable | 1 | - | O | O | O | |
| | | 1: Enable | | | | | | |
| | | 2: Set by DI | | | | | | |
| 10-30 | Upper Limit of PID Target | 0.0 ~ 100.0 | 100.0 | % | O | O | O | |
| 10-31 | Lower Limit of PID Target | 0.0 ~ 100.0 | 0.0 | % | O | O | O | |
| 10-32 | PID Switching Function | 0: PID1 | 0 | | O | O | O | |
| | | 1: PID2 | | | | | | |
| | | 2: Switch to PID2 by DI | | | | | | |
| | | 3: Switch to PID2 By RTC | | | | | | |
| 10-33 | PID Maximum Feedback Value | 1~10000 | 999 | - | O | O | O | |
| 10-34 | Scaling of PID Setpoint | 0~4 | 1 | - | O | O | O | |
| 10-35 | PID Unit | 0: % | 0 | - | O | O | O | |
| | | 1: FPM | | | | | | |
| | | 2: CFM | | | | | | |

| Group 10: PID Parameters | | | | | | | | |
|--------------------------|---|-------------------------|---------|------|--------------|-----|--------|-----------|
| Code | Parameter Name | Setting Range | Default | Unit | Control Mode | | | Attribute |
| | | | | | V/F | SLV | PM SLV | |
| | | 3: PSI | | | | | | |
| | | 4: GPH | | | | | | |
| | | 5: GPM | | | | | | |
| | | 6: IN | | | | | | |
| | | 7: FT | | | | | | |
| | | 8: /s | | | | | | |
| | | 9: /m | | | | | | |
| | | 10: /h | | | | | | |
| | | 11: °F | | | | | | |
| | | 12: inW | | | | | | |
| | | 13: HP | | | | | | |
| | | 14: m/s | | | | | | |
| | | 15: MPM | | | | | | |
| | | 16: CMM | | | | | | |
| | | 17: W | | | | | | |
| | | 18: KW | | | | | | |
| | | 19: m | | | | | | |
| | | 20: °C | | | | | | |
| | | 21: RPM | | | | | | |
| | | 22: Bar | | | | | | |
| | | 23: Pa | | | | | | |
| 10-36 | PID2 Proportional Gain (P) | 0.00~10.00 | 3.00 | - | O | O | O | *1 |
| 10-37 | PID2 Integral Time (I) | 0.0~100.0 | 0.50 | s | O | O | O | *1 |
| 10-38 | PID2 Differential Time (D) | 0.00~10.00 | 0.00 | s | O | O | O | *1 |
| 10-39 | Force Frequency During PID Feedback Loss | 00.00~400.00 | 30.00 | Hz | O | O | O | |
| 10-40 | Compensation Frequency of PID Sleep Selection | 0: Disable 1: Enable | 0 | | O | O | O | |

| Group 11: Auxiliary Parameters | | | | | | | | |
|--------------------------------|--------------------------------------|---|-------------------------------|------|--------------|-----|--------|-----------|
| Code | Parameter Name | Setting Range | Default | Unit | Control Mode | | | Attribute |
| | | | | | V/F | SLV | PM SLV | |
| 11-00 | Direction Lock Selection | 0: Allow Forward and Reverse Rotation 1: Only Allow Forward Rotation 2: Only Allow Reverse Rotation | 1 | - | O | O | O | |
| 11-01 | Carrier Frequency | 0: Carrier Output Frequency Tuning 1: 1.5KHz 2~16: 2~16KHz | Inverter KVA ^{*a} | - | O | O | O | |
| 11-02 | Soft PWM Function Selection | 0: Disable 1: Enable | 1 ^{*b} | - | O | O | O | |
| 11-03 | Automatic carrier lowering selection | 0: Disable 1: Enable | 0 | - | O | X | X | |

| Group 11: Auxiliary Parameters | | | | | | | | |
|--------------------------------|--|--|-------------------|------|--------------|-----|--------|-----------|
| Code | Parameter Name | Setting Range | Default | Unit | Control Mode | | | Attribute |
| | | | | | V/F | SLV | PM SLV | |
| 11-04 | S-curve Time Setting at the Start of Acceleration | 0.00~2.50 | 0.20 | s | O | O | O | |
| 11-05 | S-curve Time Setting at the End of Acceleration | 0.00~2.50 | 0.20 | s | O | O | O | |
| 11-06 | S-curve Time Setting at the Start of Deceleration | 0.00~2.50 | 0.20 | s | O | O | O | |
| 11-07 | S-curve Time Setting at the End of Deceleration | 0.00~2.50 | 0.20 | s | O | O | O | |
| 11-08 | Jump Frequency 1 | 0.0~400.0 | 0.0 | Hz | O | O | O | |
| 11-09 | Jump Frequency 2 | 0.0~400.0 | 0.0 | Hz | O | O | O | |
| 11-10 | Jump Frequency 3 | 0.0~400.0 | 0.0 | Hz | O | O | O | |
| 11-11 | Jump Frequency Width | 0.0~25.5 | 1.0 | Hz | O | O | O | |
| 11-12 | Manual Energy Saving Gain | 0~100 | 80 | % | O | X | X | |
| 11-13 | Keypad Return Time | 0~120 | 60 | Sec | O | O | O | |
| 11-18 | Manual Energy Saving Frequency | 0.00~400.00 | 0.00 | Hz | O | X | X | |
| 11-19 | Automatic Energy Saving Function | 0: Automatic Energy Saving is Disabled | 0 | - | O | X | X | |
| | | 1: Automatic Energy Saving is Enabled | | | | | | |
| 11-20 | Filter Time of Automatic Energy Saving | 0~200 | 140 | ms | O | X | X | |
| 11-21 | Voltage Upper Limit of Energy Saving Tuning | 0~100 | 100 | % | O | X | X | |
| 11-22 | Adjustment Time of Automatic Energy Saving | 0~5000 | 20 | ms | O | X | X | *1 |
| 11-23 | Detection Level of Automatic Energy Saving | 0~100 | 10 | % | O | X | X | |
| 11-24 | Coefficient of Automatic Energy Saving | 0.00~655.35 | KVA ^{*a} | - | O | X | X | |
| 11-29 | Auto De-rating Selection | 0: Disable | 0 | - | O | X | X | |
| | | 1: Enable | | | | | | |
| 11-30 | Variable Carrier Frequency Max. Limit | 2~16 | KVA ^{*a} | KHz | O | X | X | |
| 11-31 | Variable Carrier Frequency Min. Limit | 2~16 | KVA ^{*a} | KHz | O | X | X | |
| 11-32 | Variable Carrier Frequency Proportional Gain | 00~99 | 00 | - | O | X | X | |
| 11-41 | Frequency Reference Loss Operation Selection | 0: Decelerate to Stop when Reference Frequency Disappears | 0 | - | O | O | O | |
| | | 1: Operation is Set by 11-42 when Reference Frequency Disappears | | | | | | |
| 11-42 | Operation Frequency after Frequency Reference Loss | 0.0~100.0 | 80.0 | % | O | O | O | |
| 11-43 | Hold Frequency at Start | 0.0~400.0 | 0.0 | Hz | O | O | O | |
| 11-44 | Frequency Hold Time at Start | 0.0~10.0 | 0.0 | s | O | O | O | |

| Group 11: Auxiliary Parameters | | | | | | | | |
|--------------------------------|--|--|---------|------|--------------|-----|-----------|-----------|
| Code | Parameter Name | Setting Range | Default | Unit | Control Mode | | | Attribute |
| | | | | | V/F | SLV | PM SLV | |
| 11-45 | Hold Frequency at Stop | 0.0~400.0 | 0.0 | Hz | O | O | O | |
| 11-46 | Frequency Hold Time at Stop | 0.0~10.0 | 0.0 | s | O | O | O | |
| 11-47 | KEB Deceleration Time | 0.0~25.5 | 0.0 | s | O | X | X | *1 |
| 11-48 | KEB Detection Level | 230V: 190~210 | 200 | V | O | X | X | |
| | | 460V: 380~420 | 400 | | | | | |
| 11-51 | Braking Selection of Zero Speed | 0: Disable | 0 | - | O | X | X | |
| | | 1: Enable | | | | | | |
| 11-54 | Output KWH Initialization | 0: Do not Clear Output KWH | 0 | - | O | O | O | *1 |
| | | 1: Clear Output KWH | | | | | | |
| 11-55 | STOP Key Selection | 0: Stop Key is Disabled when the Operation Command is not Provided by Keypad. | 1 | - | O | O | O | |
| | | 1: Stop Key is Enabled when the Operation Command is not Provided by Keypad. | | | | | | |
| 11-56 | UP/DOWN Selection | 0: When UP/DOWN in Keypad is Disabled, it will be Enabled if Press ENTER after Frequency Modification. | 0 | - | O | O | O | |
| | | 1: When UP/DOWN in Keypad is Enabled, it will be Enabled after Frequency Modification. | | | | | | |
| 11-58 | Record Reference Frequency | 0: Disable | 0 | - | O | O | O | *1 |
| | | 1: Enable | | | | | | |
| 11-59 | Anti-Hunting Protection Gain | 0.01~2.50 | 0.01 | | O | X | X | |
| 11-60 | Upper Limit of Anti-Hunting Protection | 0~100 | 30 | % | O | X | X | |
| 11-61 | Filter Time of Anti-Hunting Protection | 0~100 | 0 | | O | X | X | |
| 11-62 | Prevention of Oscillation Selection | 0: Mode 1 1: Mode 2 | 1 | | O | X | X | |
| 11-63 | Flux-Enhancing Selection | 0: Disable | 1 | | X | O | X | |
| | | 1: Enable | | | | | | |

*a: KVA means the default value of this parameter depends on inverter rating.

*b: Default value is 1 only for V/F mode.

Group 12: Monitoring Parameters

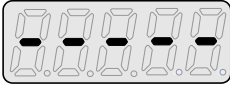
| Code | Parameter Name | Setting Range | Default | Unit | Control Mode | | | Attribute |
|-------|--|--|---------|------|--------------|-----|--------|-----------|
| | | | | | V/F | SLV | PM SLV | |
| 12-00 | Display Screen Selection (LED) | 00000~77777 From the left most bit, it displays the selected parameter. Press DSP key successively. 0: No display 1: Output Current 2: Output Voltage 3: DC Bus Voltage 4: Heatsink Temperature 5: PID Feedback 6: AI1 Value 7: AI2 Value | 00000 | - | O | O | O | *5 |
| 12-01 | PID Feedback Display Mode (LED) | 0: Display the Feedback Value by Integer (xxx) 1: Display the Feedback Value by the Value with First Decimal Place (xx.x) 2: Display the Feedback Value by the Value with Second Decimal Place (x.xx) | 0 | | O | O | O | *5 |
| 12-02 | PID Feedback Display Unit Setting (LED) | 0: xxxxx (no unit) 1: xxxPb (pressure) 2: xxxFL (flow) | 0 | | O | O | O | *5 |
| 12-03 | Line Speed Display (LED) | 0~65535 | 0 | RPM | O | O | O | *5 |
| 12-04 | Line Speed Display Mode (LED) | 0: Display Inverter Output Frequency 1: Line Speed Display at Integer.(xxxx) 2: Line Speed Display at One Decimal Place. (xxxx.x) 3: Line Speed Display at Two Decimal Places. (xx.xx) 4: Line Speed Display at Three Decimal Places. (xx.xxx) | 0 | | O | O | O | *5 |
| 12-05 | Status display of digital input terminal (LED / LCD) | LED display is shown as below no input  correspondences to input and output | - | - | O | O | O | |

Group 12: Monitoring Parameters

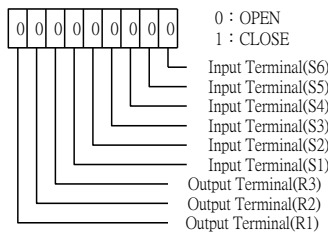
| Code | Parameter Name | Setting Range | Default | Unit | Control Mode | | | Attribute |
|-------|------------------------------------|---|---------|------|-----------------------|-----------------------|-----------------------|-----------|
| | | | | | V/F | SLV | PM SLV | |
| | |  <p>LCD display is shown as below</p>  | | | | | | |
| 12-11 | Output Current of Current Fault | Display the output current of current fault | - | A | <input type="radio"/> | <input type="radio"/> | <input type="radio"/> | |
| 12-12 | Output Voltage of Current Fault | Display the output voltage of current fault | - | V | <input type="radio"/> | <input type="radio"/> | <input type="radio"/> | |
| 12-13 | Output Frequency of Current Fault | Display the output frequency of current fault | - | Hz | <input type="radio"/> | <input type="radio"/> | <input type="radio"/> | |
| 12-14 | DC Voltage of Current Fault | Display the DC voltage of current fault | - | V | <input type="radio"/> | <input type="radio"/> | <input type="radio"/> | |
| 12-15 | Frequency Command of Current Fault | Display the frequency command of current fault | - | Hz | <input type="radio"/> | <input type="radio"/> | <input type="radio"/> | |
| 12-16 | Frequency Command | If set via keypad, it only allows monitoring frequency command. | - | Hz | <input type="radio"/> | <input type="radio"/> | <input type="radio"/> | |
| 12-17 | Output Frequency | Display the current output frequency | - | Hz | <input type="radio"/> | <input type="radio"/> | <input type="radio"/> | |
| 12-18 | Output Current | Display the current output current | - | A | <input type="radio"/> | <input type="radio"/> | <input type="radio"/> | |
| 12-19 | Output Voltage | Display the current output voltage | - | V | <input type="radio"/> | <input type="radio"/> | <input type="radio"/> | |
| 12-20 | DC Voltage | Display the current DC voltage | - | V | <input type="radio"/> | <input type="radio"/> | <input type="radio"/> | |
| 12-21 | Output Power | Display the current output power | - | kW | <input type="radio"/> | <input type="radio"/> | <input type="radio"/> | |
| 12-22 | Motor's Rotation Speed | Display motor's current rotation speed in VF/SLV mode Motor's rotation speed = output power x(120/motor's pole number) In PG/SV mode, motor's rotation speed is calculated by feedback frequency. Max limit is 65535 | - | rpm | <input type="radio"/> | <input type="radio"/> | <input type="radio"/> | |
| 12-23 | Output Power Factor | Display the current output power factor | - | - | <input type="radio"/> | <input type="radio"/> | <input type="radio"/> | |
| 12-24 | Control Mode | Display control mode 0 : VF 2 : SLV 5 : PM SLV | - | - | <input type="radio"/> | <input type="radio"/> | <input type="radio"/> | |

Group 12: Monitoring Parameters

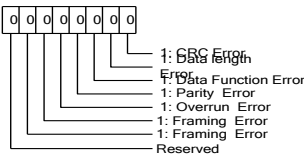
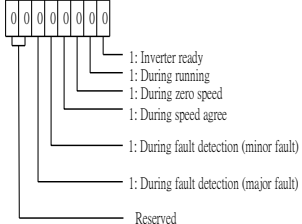
| Code | Parameter Name | Setting Range | Default | Unit | Control Mode | | | Attribute |
|-------|--|---|---------|------|--------------|-----|--------|-----------|
| | | | | | V/F | SLV | PM SLV | |
| 12-25 | AI1 Input | Display the current AI1 input (0V corresponds to 0%, 10V corresponds to 100%,) | - | % | O | O | O | |
| 12-26 | AI2 Input | Display the current AI2 input (0V or 4mA corresponds to 0%, 10V or 20mA corresponds to 100%) | - | % | O | O | O | |
| 12-27 | Torque Command | Display the current torque command (100% corresponds to motor torque) | - | % | X | O | O | |
| 12-28 | Motor Torque Current (Iq) | Display the current q-axis current | - | % | X | O | O | |
| 12-29 | Motor Excitation Current (Id) | Display the current d-axis current | - | % | X | O | O | |
| 12-36 | PID Input | Display input error of the PID controller (PID target value - PID feedback) (100% corresponds to the maximum frequency set by 01-02 or 01-16) | 0.01 | % | O | O | O | |
| 12-37 | PID Output | Display output of the PID controller (100% corresponds to the maximum frequency set by 01-02 or 01-16) | - | % | O | O | O | |
| 12-38 | PID Setpoint | Display the target value of the PID controller (100% corresponds to the maximum frequency set by 01-02 or 01-16) | - | % | O | O | O | |
| 12-39 | PID Feedback | Display the feedback value of the PID controller (100% corresponds to the maximum frequency set by 01-02 or 01-16) | - | % | O | O | O | |
| 12-41 | Heatsink Temperature | Display the heatsink temperature of IGBT temperature. | - | °C | O | O | O | |
| 12-42 | RS-485 Error Code |  | - | - | O | O | O | |
| 12-43 | Inverter Status |  | 101B | - | O | O | O | |
| 12-45 | Recent Fault Message | Display current fault message | - | - | O | O | O | |
| 12-46 | Previous Fault Message | Display previous fault message | - | - | O | O | O | |
| 12-47 | 2 nd Previous Fault Message | Displays 2 nd previous fault message | - | - | O | O | O | |
| 12-48 | 3 rd Previous Fault Message | Displays 3 rd Previous Fault Message | - | - | O | O | O | |
| 12-49 | 4 th Previous Fault Message | Displays 4 th Previous Fault Message | - | - | O | O | O | |
| 12-50 | DIO Status of Current Fault | Display the DI/DO status of current fault | - | - | O | O | O | |

| Group 12: Monitoring Parameters | | | | | | | | |
|---------------------------------|--|--|----------|------|--------------|-----|--------|-----------|
| Code | Parameter Name | Setting Range | Default | Unit | Control Mode | | | Attribute |
| | | | | | V/F | SLV | PM SLV | |
| | | Description is similar to 12-05 | | | | | | |
| 12-51 | Inverter Status of Current Fault | Display the inverter status of current fault Description is similar to 12-43 | - | - | O | O | O | |
| 12-52 | Trip Time 1 of Current Fault | Display the operation time of current fault, 12-53 shows the days and 12-52 shows the hours. | - | Hr | O | O | O | |
| 12-53 | Trip Time 2 of Current Fault | | - | day | O | O | O | |
| 12-54 | Frequency Command of Previous Fault | Display frequency command of previous fault | - | Hz | O | O | O | |
| 12-55 | Output Frequency of Previous Fault | Display output frequency of previous fault | - | Hz | O | O | O | |
| 12-56 | Output Current of Previous Fault | Display output current of previous fault | - | A | O | O | O | |
| 12-57 | Output Voltage of Previous Fault | Display output voltage of previous fault | - | V | O | O | O | |
| 12-58 | DC Voltage of Previous Fault | Display DC voltage of previous fault | - | V | O | O | O | |
| 12-59 | DIO Status of Previous Fault | Display DI/DO status of previous fault Description is similar to 12-05 | - | - | O | O | O | |
| 12-60 | Inverter Status of Previous Fault | Display inverter status of previous fault Description is similar to 12-43 | - | - | O | O | O | |
| 12-61 | Trip time 1 of last fault | Display the operation time of last time's fault, 12-62 shows the days and 12-61 shows the hours. | - | Hr | O | O | O | |
| 12-62 | Trip time 2 of last fault | | - | day | O | O | O | |
| 12-63 | Recent warning messages | Display the recent warning messages | - | - | O | O | O | |
| 12-64 | Previous warning message | Display the previous warning message | - | - | O | O | O | |
| 12-67 | Accumulative Energy (kWhr) | 0.0 ~ 999.9 | | kWhr | O | O | O | |
| 12-68 | Accumulative Energy (MWhr) | 0 ~ 60000 | | MWhr | O | O | O | |
| 12-69 | Accumulative Electricity Price (\$) | 0 ~ 9999 | | \$ | O | O | O | |
| 12-70 | Accumulative Electricity Price (10000\$) | 0 ~ 60000 | | \$ | O | O | O | |
| 12-71 | Flow Meter Feedback | 1 ~ 50000 | | GPM | O | O | O | |
| 12-72 | RTC Date | 12.01.01 ~ 99.12.31 | 12.01.01 | | O | O | O | |
| 12-73 | RTC Time | 00:00 ~ 23:59 | 00:00 | | O | O | O | |
| 12-74 | Operating Pressure Setting | 0.01 ~ 25.50 | 2.00 | PSI | O | X | X | |
| 12-75 | Pressure Feedback Value | 0.01 ~ 25.50 | - | PSI | O | X | X | |
| 12-76 | No-Load Voltage | 0.0 ~ 600.0 | - | V | X | O | X | |
| 12-77 | Flow Meter Target Setting | 1 ~ 50000 | - | GPM | O | O | O | |
| 12-79 | Pulse Input Percentage | 0.0~100.0 | - | % | O | O | O | |

* Models of inverter ratings above 230V 50HP (including 50HP) and 460V 75HP (including 75HP) in IP20 enclosure do not include heatsink temperature display.

* Maximum upper limit in motor speed (rpm) of parameter 12-22 is 65535.

| Group 13: Maintenance Function Group | | | | | | | | |
|--------------------------------------|--|--|---------|------|--------------|-----|--------|-----------|
| Code | Parameter Name | Setting Range | Default | Unit | Control Mode | | | Attribute |
| | | | | | V/F | SLV | PM SLV | |
| 13-00 | Inverter Rating Selection | 00H~FFH | - | - | ○ | ○ | ○ | *4 |
| 13-01 | Software Version | 0.0-9.9 | - | - | ○ | ○ | ○ | *4 |
| 13-03 | Cumulative Operation Hours 1 | 0~23 | - | hr | ○ | ○ | ○ | *4 |
| 13-04 | Cumulative Operation Hours 2 | 0~65535 | - | day | ○ | ○ | ○ | *4 |
| 13-05 | Selection of Cumulative Operation Time | 0: Cumulative time in power on | | | | | | *1 |
| | | 1: Cumulative time in operation | | | | | | |
| 13-06 | Parameters Locked | 0: Parameters out of 13-06 are read-only. | | | | | | *1 |
| | | 1: Only user parameter is enabled. | | | | | | |
| | | 2: All parameters are writable. | | | | | | |
| 13-07 | Parameter Password Function | 0~9999 | 0 | - | ○ | ○ | ○ | |
| 13-08 | Restore Factory Setting | 0: No Initialization | 0 | - | ○ | ○ | ○ | |
| | | 2: 2 wire Initialization (220/440V, 60Hz) | | | | | | |
| | | 3: 3 wire Initialization (220/440V, 60Hz) | | | | | | |
| | | 4: 2 wire Initialization (230/415V, 50Hz) | | | | | | |
| | | 5: 3 wire Initialization (230/415V, 50Hz) | | | | | | |
| | | 6: 2 wire Initialization (200/380V, 50Hz) | | | | | | |
| | | 7: 3 wire Initialization (200/380V, 50Hz) | | | | | | |
| | | 8: PLC Initialization | | | | | | |
| | | 9: 2 Wire Initialization (230V/460V, 60Hz) | | | | | | |
| | | 10: 3 Wire Initialization (230V/460V, 60Hz) | | | | | | |
| Others: Reserved | | | | | | | | |
| 13-09 | Fault History Clearance Function | 0: Do not Clear Fault History | 0 | - | ○ | ○ | ○ | *1 |
| | | 1: Clear Fault History | | | | | | |
| 13-10 | Password Function 2 | 0 ~ 9999 | 0 | | ○ | ○ | ○ | |
| 13-11 | C/B CPLD Ver. | 0.00~9.99 | 0.00 | | ○ | ○ | ○ | |
| 13-12 | Option Card Id | 0~255 | 0 | | ○ | ○ | ○ | |
| 13-13 | Option Card CPLD Ver. | 0.00~9.99 | 0.00 | | ○ | ○ | ○ | |
| 13-14 | Fault Storage Selection | 0: Auto Restart Fault Messages are not saved in fault history during Auto-Restart. | 0 | | | ○ | ○ | ○ |
| | | 1: Auto Restart Fault Messages are saved in fault history during Auto-Restart. | | | | | | |

Group 14: PLC Setting Parameters

| Code | Parameter Name | Setting Range | Default | Unit | Control Mode | | | Attribute |
|-------|-------------------------|---------------|---------|------|--------------|-----|-----------|-----------|
| | | | | | V/F | SLV | PM SLV | |
| 14-00 | T1 Set Value 1 | 0~9999 | 0 | - | ○ | ○ | ○ | |
| 14-01 | T1 Set Value 2 (Mode 7) | 0~9999 | 0 | - | ○ | ○ | ○ | |
| 14-02 | T2 Set Value 1 | 0~9999 | 0 | - | ○ | ○ | ○ | |
| 14-03 | T2 Set Value 2 (Mode 7) | 0~9999 | 0 | - | ○ | ○ | ○ | |
| 14-04 | T3 Set Value 1 | 0~9999 | 0 | - | ○ | ○ | ○ | |
| 14-05 | T3 Set Value 2 (Mode 7) | 0~9999 | 0 | - | ○ | ○ | ○ | |
| 14-06 | T4 Set Value 1 | 0~9999 | 0 | - | ○ | ○ | ○ | |
| 14-07 | T4 Set Value 2 (Mode 7) | 0~9999 | 0 | - | ○ | ○ | ○ | |
| 14-08 | T5 Set Value 1 | 0~9999 | 0 | - | ○ | ○ | ○ | |
| 14-09 | T5 Set Value 2 (Mode 7) | 0~9999 | 0 | - | ○ | ○ | ○ | |
| 14-10 | T6 Set Value 1 | 0~9999 | 0 | - | ○ | ○ | ○ | |
| 14-11 | T6 Set Value 2 (Mode 7) | 0~9999 | 0 | - | ○ | ○ | ○ | |
| 14-12 | T7 Set Value 1 | 0~9999 | 0 | - | ○ | ○ | ○ | |
| 14-13 | T7 Set Value 2 (Mode 7) | 0~9999 | 0 | - | ○ | ○ | ○ | |
| 14-14 | T8 Set Value 1 | 0~9999 | 0 | - | ○ | ○ | ○ | |
| 14-15 | T8 Set Value 2 (Mode 7) | 0~9999 | 0 | - | ○ | ○ | ○ | |
| 14-16 | C1 Set Value | 0~65535 | 0 | - | ○ | ○ | ○ | |
| 14-17 | C2 Set Value | 0~65535 | 0 | - | ○ | ○ | ○ | |
| 14-18 | C3 Set Value | 0~65535 | 0 | - | ○ | ○ | ○ | |
| 14-19 | C4 Set Value | 0~65535 | 0 | - | ○ | ○ | ○ | |
| 14-20 | C5 Set Value | 0~65535 | 0 | - | ○ | ○ | ○ | |
| 14-21 | C6 Set Value | 0~65535 | 0 | - | ○ | ○ | ○ | |
| 14-22 | C7 Set Value | 0~65535 | 0 | - | ○ | ○ | ○ | |
| 14-23 | C8 Set Value | 0~65535 | 0 | - | ○ | ○ | ○ | |
| 14-24 | AS1 Set Value 1 | 0~65535 | 0 | - | ○ | ○ | ○ | |
| 14-25 | AS1 Set Value 2 | 0~65535 | 0 | - | ○ | ○ | ○ | |
| 14-26 | AS1 Set Value 3 | 0~65535 | 0 | - | ○ | ○ | ○ | |
| 14-27 | AS2 Set Value 1 | 0~65535 | 0 | - | ○ | ○ | ○ | |
| 14-28 | AS2 Set Value 2 | 0~65535 | 0 | - | ○ | ○ | ○ | |
| 14-29 | AS2 Set Value 3 | 0~65535 | 0 | - | ○ | ○ | ○ | |
| 14-30 | AS3 Set Value 1 | 0~65535 | 0 | - | ○ | ○ | ○ | |
| 14-31 | AS3 Set Value 2 | 0~65535 | 0 | - | ○ | ○ | ○ | |
| 14-32 | AS3 Set Value 3 | 0~65535 | 0 | - | ○ | ○ | ○ | |
| 14-33 | AS4 Set Value 1 | 0~65535 | 0 | - | ○ | ○ | ○ | |
| 14-34 | AS4 Set Value 2 | 0~65535 | 0 | - | ○ | ○ | ○ | |
| 14-35 | AS4 Set Value 3 | 0~65535 | 0 | - | ○ | ○ | ○ | |
| 14-36 | MD1 Set Value 1 | 0~65535 | 1 | - | ○ | ○ | ○ | |
| 14-37 | MD1 Set Value 2 | 0~65535 | 1 | - | ○ | ○ | ○ | |
| 14-38 | MD1 Set Value 3 | 0~65535 | 1 | - | ○ | ○ | ○ | |
| 14-39 | MD2 Set Value 1 | 0~65535 | 1 | - | ○ | ○ | ○ | |
| 14-40 | MD2 Set Value 2 | 0~65535 | 1 | - | ○ | ○ | ○ | |
| 14-41 | MD2 Set Value 3 | 0~65535 | 1 | - | ○ | ○ | ○ | |
| 14-42 | MD3 Set Value 1 | 0~65535 | 1 | - | ○ | ○ | ○ | |

| Group 14: PLC Setting Parameters | | | | | | | | |
|----------------------------------|-----------------|---------------|---------|------|--------------|-----|-----------|-----------|
| Code | Parameter Name | Setting Range | Default | Unit | Control Mode | | | Attribute |
| | | | | | V/F | SLV | PM SLV | |
| 14-43 | MD3 Set Value 2 | 0~65535 | 1 | - | ○ | ○ | ○ | |
| 14-44 | MD3 Set Value 3 | 0~65535 | 1 | - | ○ | ○ | ○ | |
| 14-45 | MD4 Set Value 1 | 0~65535 | 1 | - | ○ | ○ | ○ | |
| 14-46 | MD4 Set Value 2 | 0~65535 | 1 | - | ○ | ○ | ○ | |
| 14-47 | MD4 Set Value 3 | 0~65535 | 1 | - | ○ | ○ | ○ | |

| Group 15: PLC Monitoring Parameters | | | | | | | | |
|-------------------------------------|-----------------------------|---------------|---------|------|--------------|-----|-----------|-----------|
| Code | Parameter Name | Setting Range | Default | Unit | Control Mode | | | Attribute |
| | | | | | V/F | SLV | PM SLV | |
| 15-00 | T1 Current Value 1 | 0~9999 | 0 | - | ○ | ○ | ○ | |
| 15-01 | T1 Current Value 2 (Mode 7) | 0~9999 | 0 | - | ○ | ○ | ○ | |
| 15-02 | T2 Current Value 1 | 0~9999 | 0 | - | ○ | ○ | ○ | |
| 15-03 | T2 Current Value 2 (Mode 7) | 0~9999 | 0 | - | ○ | ○ | ○ | |
| 15-04 | T3 Current Value 1 | 0~9999 | 0 | - | ○ | ○ | ○ | |
| 15-05 | T3 Current Value 2 (Mode 7) | 0~9999 | 0 | - | ○ | ○ | ○ | |
| 15-06 | T4 Current Value 1 | 0~9999 | 0 | - | ○ | ○ | ○ | |
| 15-07 | T4 Current Value 2 (Mode 7) | 0~9999 | 0 | - | ○ | ○ | ○ | |
| 15-08 | T5 Current Value 1 | 0~9999 | 0 | - | ○ | ○ | ○ | |
| 15-09 | T5 Current Value 2 (Mode 7) | 0~9999 | 0 | - | ○ | ○ | ○ | |
| 15-10 | T6 Current Value 1 | 0~9999 | 0 | - | ○ | ○ | ○ | |
| 15-11 | T6 Current Value 2 (Mode 7) | 0~9999 | 0 | - | ○ | ○ | ○ | |
| 15-12 | T7 Current Value 1 | 0~9999 | 0 | - | ○ | ○ | ○ | |
| 15-13 | T7 Current Value 2 (Mode 7) | 0~9999 | 0 | - | ○ | ○ | ○ | |
| 15-14 | T8 Current Value 1 | 0~9999 | 0 | - | ○ | ○ | ○ | |
| 15-15 | T8 Current Value 2 (Mode 7) | 0~9999 | 0 | - | ○ | ○ | ○ | |
| 15-16 | C1 Current Value | 0~65535 | 0 | - | ○ | ○ | ○ | |
| 15-17 | C2 Current Value | 0~65535 | 0 | - | ○ | ○ | ○ | |
| 15-18 | C3 Current Value | 0~65535 | 0 | - | ○ | ○ | ○ | |
| 15-19 | C4 Current Value | 0~65535 | 0 | - | ○ | ○ | ○ | |
| 15-20 | C5 Current Value | 0~65535 | 0 | - | ○ | ○ | ○ | |
| 15-21 | C6 Current Value | 0~65535 | 0 | - | ○ | ○ | ○ | |
| 15-22 | C7 Current Value | 0~65535 | 0 | - | ○ | ○ | ○ | |
| 15-23 | C8 Current Value | 0~65535 | 0 | - | ○ | ○ | ○ | |
| 15-24 | AS1 Results | 0~65535 | 0 | - | ○ | ○ | ○ | |
| 15-25 | AS2 Results | 0~65535 | 0 | - | ○ | ○ | ○ | |
| 15-26 | AS3 Results | 0~65535 | 0 | - | ○ | ○ | ○ | |
| 15-27 | AS4 Results | 0~65535 | 0 | - | ○ | ○ | ○ | |
| 15-28 | MD1 Results | 0~65535 | 0 | - | ○ | ○ | ○ | |
| 15-29 | MD2 Results | 0~65535 | 0 | - | ○ | ○ | ○ | |
| 15-30 | MD3 Results | 0~65535 | 0 | - | ○ | ○ | ○ | |
| 15-31 | MD4 Results | 0~65535 | 0 | - | ○ | ○ | ○ | |
| 15-32 | TD Current Value | 0~65535 | 0 | - | ○ | ○ | ○ | |

| Group 16: LCD Function Parameters | | | | | | | | |
|-----------------------------------|-------------------------------|--|---------|------|-----------------------|-----------------------|-----------------------|-----------|
| Code | Parameter Name | Setting Range | Default | Unit | Control Mode | | | Attribute |
| | | | | | V/F | SLV | PM SLV | |
| 16-00 | Main Screen Monitoring | 5~79 When using LCD to operate, the monitored item displays in the first line. (default is frequency command) | 16 | - | <input type="radio"/> | <input type="radio"/> | <input type="radio"/> | *1 |
| 16-01 | Sub-Screen Monitoring 1 | 5~79 (Parameter 12-05~12-79) When using LCD to operate, the monitored item displays in the second line. (default is output frequency) | 17 | - | <input type="radio"/> | <input type="radio"/> | <input type="radio"/> | *1 |
| 16-02 | Sub-Screen Monitoring 2 | 5~79 (Parameter 12-05~12-79) when using LCD to operate, the monitored item displays in the third line. (default is output current) | 18 | - | <input type="radio"/> | <input type="radio"/> | <input type="radio"/> | *1 |
| 16-03 | Selection of Display Unit | 0~39999: Determine the display way and unit of frequency command | 0 | - | <input type="radio"/> | <input type="radio"/> | <input type="radio"/> | |
| | | 0: Frequency display unit is 0.01Hz | | | | | | |
| | | 1: Frequency display unit 0.01% | | | | | | |
| | | 2: Rpm display; motor rotation speed is set by the control modes to select IM (02-07)/ PM (22-03) motor poles to calculate. | | | | | | |
| | | 3~39: Reserved | | | | | | |
| | | 40~9999: Users specify the format; Input 0XXXX represents the display of XXXX at 100%. | | | | | | |
| | | 10001~19999: Users specify the format; Input 1XXXX represents the display of XXX.X at 100%. | | | | | | |
| | | 20001~29999: Users specify the format; Input 2XXXX represents the display of XX.XX at 100%. | | | | | | |
| | | 30001~39999: Users specify the format, Input 3XXXX represents the display of X.XXX at 100%. | | | | | | |
| 16-04 | Selection of Engineering Unit | 0: No Unit | 0 | - | <input type="radio"/> | <input type="radio"/> | <input type="radio"/> | |
| | | 1: FPM | | | | | | |
| | | 2: CFM | | | | | | |
| | | 3: PSI | | | | | | |
| | | 4: GPH | | | | | | |
| | | 5: GPM | | | | | | |
| | | 6: IN | | | | | | |
| | | 7: FT | | | | | | |
| | | 8: /s | | | | | | |

| Group 16: LCD Function Parameters | | | | | | | | |
|-----------------------------------|----------------------------------|---|----------|------|--------------|-----|--------|-----------|
| Code | Parameter Name | Setting Range | Default | Unit | Control Mode | | | Attribute |
| | | | | | V/F | SLV | PM SLV | |
| | | 9: /m | | | | | | |
| | | 10: /h | | | | | | |
| | | 11: °F | | | | | | |
| | | 12: inW | | | | | | |
| | | 13: HP | | | | | | |
| | | 14: m/s | | | | | | |
| | | 15: MPM | | | | | | |
| | | 16: CMM | | | | | | |
| | | 17: W | | | | | | |
| | | 18: KW | | | | | | |
| | | 19: m | | | | | | |
| | | 20: °C | | | | | | |
| | | 21: RPM | | | | | | |
| | | 22: Bar | | | | | | |
| | | 23: Pa | | | | | | |
| 16-05 | LCD Backlight | 0~7 | 5 | - | 0 | 0 | 0 | *1 |
| 16-07 | Copy Function Selection | 0: Disabled | 0 | - | 0 | 0 | 0 | |
| | | 1: Read inverter parameters and save to the operator. | | | | | | |
| | | 2: Write the operator parameters to inverter. | | | | | | |
| | | 3: Compare parameters of inverter and operator. | | | | | | |
| 16-08 | Operator Copy Function | 0: Do not allow to read inverter parameters and save to the operator. | 0 | - | 0 | 0 | 0 | |
| | | 1: Allow to read inverter parameters and save to the operator. | | | | | | |
| 16-09 | Operator Removed (LCD) Selection | 0: Continue operating when LCD operator is removed. | 0 | - | 0 | 0 | 0 | *1 |
| | | 1: Display fault and stop when LCD operator is removed | | | | | | |
| 16-10 | RTC Function Selection | 0: Hide | 0 | | 0 | 0 | 0 | |
| | | 1: Display | | | | | | |
| 16-11 | RTC Date Setting | 12.01.01 ~ 99.12.31 | 12.01.01 | | 0 | 0 | 0 | |
| 16-12 | RTC Time Setting | 00:00 ~ 23:59 | 00:00 | | 0 | 0 | 0 | |
| 16-13 | RTC Timer Function Selection | 0: Disable | 0 | | 0 | 0 | 0 | |
| | | 1: Enable | | | | | | |
| | | 2: Set by DI | | | | | | |
| 16-14 | P1 Start Time | 00:00 ~ 23:59 | 08:00 | | 0 | 0 | 0 | |
| 16-15 | P1 Stop Time | 00:00 ~ 23:59 | 18:00 | | 0 | 0 | 0 | |
| 16-16 | P1 Start Date | 1:Mon, 2:Tue, 3:Wed, | 1 | | 0 | 0 | 0 | |
| 16-17 | P1 Stop Date | 4:Thu,;5:Fri,;6:Sat, 7:Sun | 5 | | 0 | 0 | 0 | |
| 16-18 | P2 Start Time | 00:00 ~ 23:59 | 08:00 | | 0 | 0 | 0 | |

| Group 16: LCD Function Parameters | | | | | | | | |
|-----------------------------------|-------------------------|--|---------|------|-----------------------|-----------------------|-----------------------|-----------|
| Code | Parameter Name | Setting Range | Default | Unit | Control Mode | | | Attribute |
| | | | | | V/F | SLV | PM SLV | |
| 16-19 | P2 Stop Time | 00:00 ~ 23:59 | 18:00 | | <input type="radio"/> | <input type="radio"/> | <input type="radio"/> | |
| 16-20 | P2 Start Date | 1:Mon,2:Tue,3:Wed, | 1 | | <input type="radio"/> | <input type="radio"/> | <input type="radio"/> | |
| 16-21 | P2 Stop Date | 4:Thu,;5:Fri,;6:Sat, 7:Sun | 5 | | <input type="radio"/> | <input type="radio"/> | <input type="radio"/> | |
| 16-22 | P3 Start Time | 00:00 ~ 23:59 | 08:00 | | <input type="radio"/> | <input type="radio"/> | <input type="radio"/> | |
| 16-23 | P3 Stop Time | 00:00 ~ 23:59 | 18:00 | | <input type="radio"/> | <input type="radio"/> | <input type="radio"/> | |
| 16-24 | P3 Start Date | 1:Mon,2:Tue,3:Wed, | 1 | | <input type="radio"/> | <input type="radio"/> | <input type="radio"/> | |
| 16-25 | P3 Stop Date | 4:Thu,;5:Fri,;6:Sat, 7:Sun | 5 | | <input type="radio"/> | <input type="radio"/> | <input type="radio"/> | |
| 16-26 | P4 Start Time | 00:00 ~ 23:59 | 08:00 | | <input type="radio"/> | <input type="radio"/> | <input type="radio"/> | |
| 16-27 | P4 Stop Time | 00:00 ~ 23:59 | 18:00 | | <input type="radio"/> | <input type="radio"/> | <input type="radio"/> | |
| 16-28 | P4 Start Date | 1:Mon, 2:Tue, 3:Wed, | 1 | | <input type="radio"/> | <input type="radio"/> | <input type="radio"/> | |
| 16-29 | P4 Stop Date | 4:Thu, 5:Fri, 6:Sat, 7:Sun | 5 | | <input type="radio"/> | <input type="radio"/> | <input type="radio"/> | |
| 16-30 | RTC Offset Selection | 0: Disable | 0 | | <input type="radio"/> | <input type="radio"/> | <input type="radio"/> | |
| | | 1: Enable | | | | | | |
| | | 2: Set by DI | | | | | | |
| 16-31 | RTC Offset Time Setting | 00:00 ~ 23:59 | 00:00 | - | <input type="radio"/> | <input type="radio"/> | <input type="radio"/> | |
| 16-32 | Source of Timer 1 | 0: None,1:P1, | 1 | | <input type="radio"/> | <input type="radio"/> | <input type="radio"/> | |
| 16-33 | Source of Timer 2 | 2:P2,3:P1+P2 | 2 | | <input type="radio"/> | <input type="radio"/> | <input type="radio"/> | |
| 16-34 | Source of Timer 3 | 4:P3,5:P1+P3, | 4 | | <input type="radio"/> | <input type="radio"/> | <input type="radio"/> | |
| 16-35 | Source of Timer 4 | 6:P2+P3,7:P1+P2+P3, 8:P4,9:P1+P4, 10:P2+P4, 11:P1+P2+P4 12:P3+P4 13:P1+P3+P4, 14:P2+P3+P4 15:P1+P2+P3+P4, 16:Off,17:Off+P1 18:Off+P2, 19:Off+P1+P2 20:Off+P3, 21:Off+P1+P3 22:Off+P2+P3 23:Off+P1+P2+P3 24:Off+P4 25:Off+P1+P4 26:Off+P2+P4 27:Off+P1+P2+P4 28:Off+P3+P4 29:Off+P3+P4 30:Off+P2+P3+P4 31:Off+P1+P2+P3+P4 | 8 | | <input type="radio"/> | <input type="radio"/> | <input type="radio"/> | |
| 16-36 | Selection of RTC Speed | 0: Off | 0 | | <input type="radio"/> | <input type="radio"/> | <input type="radio"/> | |

| Group 16: LCD Function Parameters | | | | | | | | |
|-----------------------------------|----------------------------|----------------------------------|---------|------|--------------|-----|--------|-----------|
| Code | Parameter Name | Setting Range | Default | Unit | Control Mode | | | Attribute |
| | | | | | V/F | SLV | PM SLV | |
| | | 1: By Timer 1 | | | | | | |
| | | 2: By Timer 2 | | | | | | |
| | | 3: By Timer 3 | | | | | | |
| | | 4: By Timer 4 | | | | | | |
| | | 5: By Timer 1+2 | | | | | | |
| 16-37 | Run Direction of RTC Speed | xxx0b: RTC Run1 Forward Rotation | | | | O | O | O |
| | | xxx1b: RTC Run1 Reverse Rotation | | | | | | |
| | | xx0xb: RTC Run2 Forward Rotation | | | | | | |
| | | xx1xb: RTC Run2 Reverse Rotation | | | | | | |
| | | x0xxb: RTC Run3 Forward Rotation | | | | | | |
| | | x1xxb: RTC Run3 Reverse Rotation | | | | | | |
| | | 0xxxb: RTC Run4 Forward Rotation | | | | | | |
| | | 1xxxb: RTC Run4 Reverse Rotation | | | | | | |

| Group 17: IM Motor Automatic Tuning Parameters | | | | | | | | |
|--|------------------------------------|--|-------------------|------|--------------|-----|--------|-----------|
| Code | Parameter Name | Setting Range | Default | Unit | Control Mode | | | Attribute |
| | | | | | V/F | SLV | PM SLV | |
| 17-00 | Mode Selection of Automatic Tuning | 0: Rotation Auto-tune | 2 [°] c | - | O | O | X | |
| | | 1: Static Auto-tune | | | | | | |
| | | 2: Stator Resistance Measurement | | | | | | |
| | | 3: Reserved | | | | | | |
| | | 4: Loop Adjust | | | | | | |
| | | 5: Rotation Auto-tune (Loop adjust + Stator Resistance + Rotation) | | | | | | |
| 6: Static Auto-tune (Loop adjust + Stator Resistance + Static) | | | | | | | | |
| 17-01 | Motor Rated Output Power | 0.00~600.00 | - | KW | O | O | X | |
| 17-02 | Motor Rated Current | 0.1~1200.0 | - | A | O | O | X | |
| 17-03 | Motor Rated Voltage | 230V: 0.0~255.0 | 230 | V | O | O | X | |
| | | 460V:0.0~510.0 | 460 | | | | | |
| 17-04 | Motor Rated Frequency | 10.0~400.0 | 60.0 | Hz | O | O | X | |
| 17-05 | Motor Rated Speed | 0~24000 | KVA ^{*a} | rpm | O | O | X | |
| 17-06 | Pole Number of Motor | 2~16 (Even) | 4 | Pole | O | O | X | |
| 17-08 | Motor No-load Voltage | 230V: 50~240 | KVA ^{*a} | V | O | O | X | |
| | | 460V:100~480 | | | | | | |
| 17-09 | Motor Excitation Current | 0.01~600.00 (15%~70% motor rated current) | KVA ^{*a} | A | O | O | X | |
| 17-10 | Automatic Tuning Start | 0: Disable | 0 | - | O | O | X | |
| | | 1: Enable | | | | | | |
| 17-11 | Error History of Automatic Tuning | 0: No Error | 0 | - | O | O | X | |
| | | 1: Motor Data Error | | | | | | |
| | | 2: Stator Resistance Tuning Error | | | | | | |

| Group 17: IM Motor Automatic Tuning Parameters | | | | | | | | |
|--|--------------------------|-----------------------------------|---------|------|--------------|-----|--------|-----------|
| Code | Parameter Name | Setting Range | Default | Unit | Control Mode | | | Attribute |
| | | | | | V/F | SLV | PM SLV | |
| | | 3. Leakage Induction Tuning Error | | | | | | |
| | | 4. Rotor Resistance Tuning Error | | | | | | |
| | | 5. Mutual Induction Tuning Error | | | | | | |
| | | 6. Reserved | | | | | | |
| | | 7. DT Error | | | | | | |
| | | 8. Motor Acceleration Error | | | | | | |
| | | 9. Warning | | | | | | |
| 17-12 | Leakage Inductance Ratio | 0.1 ~ 15.0 | 3.4 | % | X | O | X | |
| 17-13 | Slip Frequency | 0.10 ~ 20.00 | 1.00 | Hz | X | O | X | |

*c: Default value is 2 in V/F mode while it is 0 in SLV mode.

*a: KVA means the default value of this parameter will be changed by different capacities of inverter.

| Group 18: Slip Compensation Parameters | | | | | | | | |
|--|--|---------------|--------------------|------|--------------|-----|--------|-----------|
| Code | Parameter Name | Setting Range | Default | Unit | Control Mode | | | Attribute |
| | | | | | V/F | SLV | PM SLV | |
| 18-00 | Slip Compensation Gain at Low Speed | 0.00~2.50 | 0.00 ^{*d} | - | O | O | X | *1 |
| 18-01 | Slip Compensation Gain at High Speed | -1.00~1.00 | 0.0 | - | O | O | X | *1 |
| 18-02 | Slip Compensation Limit | 0~250 | 200 | % | O | X | X | |
| 18-03 | Slip Compensation Filter Time | 0.0~10.0 | 1.0 | Sec | O | X | X | |
| 18-04 | Regenerative Slip Compensation Selection | 0: Disable | 0 | - | O | X | X | |
| | | 1: Enable | | | | | | |
| 18-05 | FOC Delay Time | 1~1000 | 100 | ms | X | O | X | |
| 18-06 | FOC Gain | 0.00~2.00 | 0.1 | - | X | O | X | |

*d: Default value is 0.00 in V/F mode while it is 1.0 in SLV mode.

| Group 20 Speed Control Parameters* | | | | | | | | |
|------------------------------------|-------------------------------|--|----------------------------------|------|--------------|-----|--------|-----------|
| Code | Parameter Name | Setting Range | Default | Unit | Control Mode | | | Attribute |
| | | | | | V/F | SLV | PM SLV | |
| 20-00 | ASR Gain 1 | 0.00~250.00 | 3.00 | - | X | O | O | *1 |
| 20-01 | ASR Integral Time 1 | 0.001~10.000 | SLV: 0.500 PMSLV: 0.08, | Sec | X | O | O | *1 |
| 20-02 | ASR Gain 2 | 0.00~250.00 | 3.00 | - | X | O | O | *1 |
| 20-03 | ASR Integral Time 2 | 0.001~10.000 | SLV: 0.500 PMSLV: 0.08, | Sec | X | O | O | *1 |
| 20-04 | ASR Integral Time Limit | 0~300 | 200 | % | X | O | O | |
| 20-07 | Selection of Acceleration and | 0: PI speed control will be enabled only | 1 | - | X | O | X | |

| Group 20 Speed Control Parameters* | | | | | | | | |
|------------------------------------|---|---|---------|------|--------------|-----|--------|-----------|
| Code | Parameter Name | Setting Range | Default | Unit | Control Mode | | | Attribute |
| | | | | | V/F | SLV | PM SLV | |
| | Deceleration of P/PI | in constant speed. For accel/decel, only use P control. 1: Speed control is enabled either in constant speed or accel/decel. | | | | | | |
| 20-08 | ASR Delay Time | 0.000~0.500 | 0.004 | Sec | X | O | X | |
| 20-09 | Speed Observer Proportional (P) Gain 1 | 0.00~2.55 | 0.61 | - | X | O | X | *1 |
| 20-10 | Speed Observer Integral(I) Time 1 | 0.01~10.00 | 0.05 | Sec | X | O | X | *1 |
| 20-11 | Speed Observer Proportional (P) Gain 2 | 0.00~2.55 | 0.61 | - | X | O | X | *1 |
| 20-12 | Speed Observer Integral(I) Time 2 | 0.01~10.00 | 0.06 | Sec | X | O | X | *1 |
| 20-13 | Low-pass Filter Time Constant of Speed Feedback 1 | 1~1000 | 4 | ms | X | O | X | |
| 20-14 | Low-pass Filter Time Constant of Speed Feedback 2 | 1~1000 | 30 | ms | X | O | X | |
| 20-15 | ASR Gain Change Frequency 1 | 0.0~400.0 | 4.0 | Hz | X | O | O | |
| 20-16 | ASR Gain Change Frequency 2 | 0.0~400.0 | 8.0 | Hz | X | O | O | |
| 20-17 | Torque Compensation Gain at Low Speed | 0.00~2.50 | 1.00 | - | X | O | X | *1 |
| 20-18 | Torque Compensation Gain at High Speed | -10~10 | 0 | % | X | O | X | *1 |
| 20-33 | Constant Speed Detection Level | 0.1~5.0 | 1.0 | | X | O | O | |
| 20-34 | Compensation Gain During Speed Drop | 0~25600 | 0 | | X | O | X | |
| 20-35 | Compensation Time During Speed Drop | 0~30000 | 100 | ms | X | O | X | |

*: This parameter group is enabled in SLV and PMSLV modes.

| Group 21: Torque Control Parameters | | | | | | | | |
|-------------------------------------|------------------------------------|---------------|---------|------|--------------|-----|--------|-----------|
| Code | Parameter Name | Setting Range | Default | Unit | Control Mode | | | Attribute |
| | | | | | V/F | SLV | PM SLV | |
| 21-05 | Positive Torque Limit | 0~160 | 160 | % | X | O | O | |
| 21-06 | Negative Torque Limit | 0~160 | 160 | % | X | O | O | |
| 21-07 | Forward Regenerative Torque Limit | 0~160 | 160 | % | X | O | O | |
| 21-08 | Reversal Regenerative Torque Limit | 0~160 | 160 | % | X | O | O | |

| Group 22: PM Motor Parameters (PM Control Mode) | | | | | | | | |
|---|------------------------------------|--|---------|-------|--------------|-----|--------|-----------|
| Code | Parameter Name | Setting Range | Default | Unit | Control Mode | | | Attribute |
| | | | | | V/F | SLV | PM SLV | |
| 22-00 | Rated Power of PM Motor | 0.00~600.00 | KVA | kW | X | X | O | |
| 22-02 | Rated Current of PM Motor | 0.1~999.9 | KVA | A | X | X | O | |
| 22-03 | Pole Number of PM Motor | 2~96 | 6 | poles | X | X | O | |
| 22-04 | Rated Rotation Speed of PM Motor | 1~60000 (22-04, 22-06, only need to set one of them, the program will calculate the other.) | 1500 | rpm | X | X | O | |
| 22-05 | Maximum Rotation Speed of PM Motor | 1~60000 | 1500 | rpm | X | X | O | |
| 22-06 | PM Motor Rated Frequency | 0.0~400.0 | 75.0 | Hz | X | X | O | |
| 22-10 | PM SLV Start Current | 0 ~ 120% Motor Rated Current | 50 | % | X | X | O | |
| 22-11 | DC Injection Current Level | 0 ~ 100% Motor Rated Current | 40 | % | X | X | O | |
| 22-12 | Speed Observer kp Value | 1~10000 | 2000 | - | X | X | O | |
| 22-13 | Speed Observer ki Value | 1~1024 | 40 | - | X | X | O | |
| 22-14 | PM Motor stator Resistance | 0.001 ~ 32.767 | 1.000 | Ω | X | X | O | |
| 22-15 | PM Motor D-axis Inductance | 0.001 ~ 32.767 | 1.024 | mH | X | X | O | |
| 22-16 | PM Motor Q-axis Inductance | 0.001 ~ 32.767 | 1.024 | mH | X | X | O | |
| 22-18 | Flux-Weakening Control | 0~100 | 0 | % | X | X | O | |
| 22-21 | PM Motor Tuning | 0: Disable 1: Enable | 0 | - | X | X | O | |
| 22-22 | Fault History of IPM Motor Tuning | 0. No Error 1~4: Reserved 5: Circuit tuning time out. 6: Reserved 7: Other motor tuning errors 8: Reserved 9: Current Abnormity Occurs while Loop Adjustment. 10: Reserved 11: Stator Resistance Measurement Timeout 12: Reserved | 0 | -- | X | X | O | *4 |

| Group 23: Pump & HVAC & Compressor Function Parameters | | | | | | | | |
|--|--|--|---------|------|--------------|-----|-----------|-----------|
| Code | Parameter Name | Setting Range | Default | Unit | Control Mode | | | Attribute |
| | | | | | V/F | SLV | PM SLV | |
| 23-00 | Function Selection | 0: Disable | 0 | - | O | O | O | |
| | | 1: Pump | | | | | | |
| | | 2: HVAC | | | | | | |
| | | 3: Compressor | | | | | | |
| 23-01 | Pump Mode Selection for Single / Multi-Pump system | 0: Single Pump | 0 | | O | X | X | |
| | | 1: Master | | | | | | |
| | | 2: Slave 1 | | | | | | |
| | | 3: Slave 2 | | | | | | |
| 23-02 | Pump Setpoint | 0.01 ~ 650.00 | 2.00 | PSI | O | X | X | |
| 23-03 | Maximum Pressure Setting | 0.01 ~ 650.00 | 10.00 | PSI | O | X | X | |
| 23-04 | Pump Setpoint Source | 0: From 23-02/12-74 | 0 | 0 | O | X | X | |
| | | 1: From All | | | | | | |
| 23-05 | Display Mode Selection (LED) | 0: Display of Target and Pressure Feedback * | 0 | % | O | X | X | |
| | | 1: Only Display Setpoint | | | | | | |
| | | 2: Only Display Feedback Pressure | | | | | | |
| 23-06 | Proportion Gain (P) | 0.00~10.00 | 3.00 | - | O | X | X | |
| 23-07 | Integral Time (I) | 0.0~100.0 | 7.00 | Sec | O | X | X | |
| 23-08 | Differential Time (D) | 0.00~10.00 | 0.00 | Sec | O | X | X | |
| 23-09 | Detection Tolerance of Constant Pressure | 0.10 ~ 650.00 | 0.50 | PSI | O | X | X | |
| 23-10 | Sleep Frequency of Constant Pressure | 0.00 ~ 180.00 | 30.00 | Hz | O | X | X | |
| 23-11 | Sleep Time of Constant Pressure | 0.0 ~ 255.5 | 0.0 | Sec | O | X | X | |
| 23-12 | High Pressure Level | 0.00 ~ 650.00 | 5.00 | PSI | O | X | X | |
| 23-13 | Warning Time for High Pressure | 0.0 ~ 600.0 | 10.0 | Sec | O | X | X | |
| 23-14 | Stop Time for High Pressure | 0.0 ~ 600.0 | 20.0 | Sec | O | X | X | |
| 23-15 | Low Pressure Level | 0.00 ~ 650.00 | 0.50 | PSI | O | X | X | |
| 23-16 | Warning Time for Low Pressure | 0.0 ~ 600.0 | 10.0 | Sec | O | X | X | |
| 23-17 | Fault Time for Low Pressure | 0.0 ~ 600.0 | 20.0 | Sec | O | X | X | |
| 23-18 | Detection Time of Loss Pressure | 0.0 ~ 600.0 | 0.0 | Sec | O | X | X | |
| 23-19 | Pressure Loss Level | 0 ~ 100 | 0 | % | O | X | X | |
| 23-20 | Percentage of Pressure Level | 0: Pressure Unit Setting | 0 | | O | X | X | *9 |
| | | 1: Pressure Percentage Setting | | | | | | |
| 23-23 | Water Usage Detection Function | 0: Upward Detection | 1 | - | O | X | X | |
| | | 1: Downward Detection | | | | | | |
| 23-24 | Water Usage Detection Bias | 0.0 ~ 65.00 | 0.1 | PSI | O | X | X | |
| 23-25 | Water Usage Detection Time | 0.0 ~ 200.0 | 20.0 | Sec | O | X | X | |
| 23-26 | Acceleration Time of Water Usage Detection | 0.1 ~ 6000.0 | KVA | Sec | O | X | X | |
| 23-27 | Deceleration Time of Water Usage Detection | 0.1 ~ 6000.0 | KVA | Sec | O | X | X | |
| 23-28 | Forced Frequency Command | 0.0 ~ 200 | 0.0 | Hz- | O | X | X | |

| Group 23: Pump & HVAC & Compressor Function Parameters | | | | | | | | |
|--|-----------------------------------|-----------------------------------|---------|------|--------------|-----|-----------|-----------|
| Code | Parameter Name | Setting Range | Default | Unit | Control Mode | | | Attribute |
| | | | | | V/F | SLV | PM SLV | |
| 23-29 | Time of Multi-Pump Switch Over | 0 ~ 240 | 3 | Hr | O | X | X | |
| 23-30 | Detection Time of Multi-Pump | 0.0 ~ 30.0 | 5.0 | Sec | O | X | X | |
| 23-31 | Multi-Pump Synchronous Selection | 0: Disable | 0 | | O | X | X | |
| | | 1: Pressure Setpoint and Run/Stop | | | | | | |
| | | 2: Pressure Setpoint | | | | | | |
| | | 3: Run/Stop | | | | | | |
| 23-36 | Pump Unit Selection | 0: PSI | 0 | - | O | X | X | |
| | | 1: inW | | | | | | |
| | | 3: Bar | | | | | | |
| | | 4: Pa | | | | | | |
| 23-37 | Leakage Detection Time | 0.0~100.0 | 0.0 | Sec | O | X | X | |
| 23-38 | Leakage Detection Variation | 0.01~65.00 | 0.1 | PSI | O | X | X | |
| 23-39 | Leakage Detection Wake up Level | 0.01~65.00 | 0.5 | PSI | O | X | X | |
| 23-41 | Local/ Remote Key | 0: Disable | 1 | | O | O | O | |
| | | 1: Enable | | | | | | |
| 23-42 | Energy Reset | 0: Disable (Energy Accumulating) | 0 | | O | O | O | |
| | | 1: Enable | | | | | | |
| 23-43 | Electricity Price per kWh | 0.000 ~ 5.000 | 0.000 | \$ | O | O | O | |
| 23-44 | Pulse Output Selection | 0: Disable | 0 | | O | O | O | |
| | | 1: Unit for 0.1kWh | | | | | | |
| | | 2: Unit for 1kWh | | | | | | |
| | | 3: Unit for 10kWh | | | | | | |
| | | 4: Unit for 100kWh | | | | | | |
| | | 5: Unit for 1000kWh | | | | | | |
| 23-45 | Flow Meter Type | 0: Disable | 1 | | O | O | O | |
| | | 1: Analog Input | | | | | | |
| | | 2: Pulse Input | | | | | | |
| 23-46 | Maximum Rated Flow | 1 ~ 50000 | 10000 | GPM | O | O | O | |
| 23-47 | HVAC Setpoint | 1 ~ 50000 | 5000 | GPM | O | O | O | |
| 23-48 | Over Flow Level | 0.01 ~ 99.00 | 80.00 | % | O | O | O | |
| 23-49 | Warning Time for Over Flow | 0.0 ~ 255.0 | 3.0 | Sec | O | O | O | |
| 23-50 | Alarm Time for Over Flow | 0.0 ~ 255.0 | 6.0 | Sec | O | O | O | |
| 23-51 | Low Flow Level | 0.01 ~ 99.00 | 10.00 | % | O | O | O | |
| 23-52 | Warning Time for Low Flow | 0.0 ~ 255.0 | 3.0 | Sec | O | O | O | |
| 23-53 | Alarm Time for Low Flow | 0.0 ~ 255.0 | 6.0 | Sec | O | O | O | |
| 23-54 | Detection Function of Low Suction | 0: Disable | 0 | | O | O | O | |
| | | 1: PID Error | | | | | | |
| | | 2: Current | | | | | | |
| | | 3: Current and PID Error | | | | | | |
| 23-55 | Detection Time of Low Suction | 0 ~ 30.0 | 10.0 | Sec | O | O | O | |
| 23-56 | PID Error Level of Low Suction | 0 ~ 30 | 10 | % | O | O | O | |

| Group 23: Pump & HVAC & Compressor Function Parameters | | | | | | | | |
|--|---|---------------------|---------|------|--------------|-----|-----------|-----------|
| Code | Parameter Name | Setting Range | Default | Unit | Control Mode | | | Attribute |
| | | | | | V/F | SLV | PM SLV | |
| 23-57 | Current Level of Low Suction(Motor Rated Current) | 0 ~ 100 | 10 | % | O | O | O | |
| 23-58 | Reaction of Low Suction | 0: Disable | 0 | | O | O | O | |
| | | 1: Warning | | | | | | |
| | | 2: Fault | | | | | | |
| | | 3: Fault & Restart | | | | | | |
| 23-59 | HVAC Setpoint Source | 0: From 23-47/12-77 | 0 | | O | O | O | |
| | | 1: From AI1 | | | | | | |
| 23-60 | HVAC Unit Selection | 0: GPM | 0 | - | O | X | X | |
| | | 1: FPM | | | | | | |
| | | 3: CFM | | | | | | |
| | | 4: GPH | | | | | | |
| 23-66 | Derating of Current Level | 10~200 | 110 | % | O | X | X | |
| 23-67 | Derating Time | 1.0~20.0 | 10.0 | Sec | O | X | X | |
| 23-68 | Derating Gain | 1~100 | 90 | % | O | X | X | |
| 23-69 | OL4 Current Level | 10~200 | 120 | % | O | X | X | |
| 23-70 | OL4 Delay Time | 0~20.0 | 5.0 | Sec | O | X | X | |

***Note:** With LED keypad, setting of 23-03 needs to be lower than 9.9 PSI in the pump modes; 10-33 is lower than 1000 and 10-34=1 in the PID modes.

| Group 24: Function of 1 to 8 Option Card | | | | | | | | |
|--|--|--|---------|------|--------------|-----|--------|-----------|
| Code | Parameter Name | Setting Range | Default | Unit | Control Mode | | | Attribute |
| | | | | | V/F | SLV | PM SLV | |
| 24-00 | Function Selection of Relay Card | 0: Function of 1 to 8 Relay Card is Disabled | 0 | - | O | O | O | |
| | | 1: Fixed Modes of Inverter Pump: First on and Last off; then Stop All. | | | | | | |
| | | 2: Fixed Modes of Inverter Pump: Only Stop Inverter Pump. | | | | | | |
| | | 3: Fixed Modes of Inverter Pump: First on and First Off; then Stop All. | | | | | | |
| | | 4: Cycle Modes of Inverter Pump: First on and First Off; then Stop All. | | | | | | |
| | | 5: Cycle Modes of Inverter Pump: Only Stop Inverter Pump. | | | | | | |
| | | 6: Cycle Modes of Inverter Pump by built-in Relay: First on and First off; then Stop All | | | | | | |
| 24-01 | Selection of Relay 2-4 Function | xxx0b: Reserved | 0000b | | O | O | O | |
| | | xxx1b: Reserved | | | | | | |
| | | xx0xb: Relay 2 Disable | | | | | | |
| | | xx1xb: Relay 2 Enable | | | | | | |
| | | x0xxb: Relay 3 Disable | | | | | | |
| | | x1xxb: Relay 3 Enable | | | | | | |
| | | 0xxxb: Relay 4 Disable | | | | | | |
| 1xxxb: Relay 4 Enable | | | | | | | | |
| 24-02 | Selection of Relay 5-8 Function | xxx0b: Relay 5 Disable | 0000b | | O | O | O | |
| | | xxx1b: Relay 5 Enable | | | | | | |
| | | xx0xb: Relay 6 Disable | | | | | | |
| | | xx1xb: Relay 6 Enable | | | | | | |
| | | x0xxb: Relay 7 Disable | | | | | | |
| | | x1xxb: Relay 7 Enable | | | | | | |
| | | 0xxxb: Relay 8 Disable | | | | | | |
| 1xxxb: Relay 8 Enable | | | | | | | | |
| 24-03 | Detection Time on Fmax (Upper Limit Frequency) | 1.0 ~ 600.0 | 300.0 | Sec | O | O | O | *1 |
| 24-04 | Detection Time on Fmin (Lower Limit Frequency) | 1.0 ~ 600.0 | 300.0 | Sec | O | O | O | *1 |
| 24-05 | Switching Time of Magnetic Contactor | 0.1 ~ 20.0 | 1.00 | Sec | O | O | O | *1 |
| 24-06 | Allowable Bias of Pump Switch | 0.0 ~ 20.0 | 0.0 | % | O | O | O | *1 |
| 24-07 | Pump Control Source Selection | 0: Relay Card | 0 | | O | O | O | |
| | | 1: Control Board (Built-in Relay) | | | | | | |

4.3 Description of Parameters

| |
|-----------------------------------|
| Group 00: Basic Parameters |
|-----------------------------------|

| 00-00 | Control Mode Selection |
|-------|---|
| Range | 【0】 : V/F 【1】 : Reserved 【2】 : SLV 【3】 : Reserved 【4】 : Reserved 【5】 : PMSLV |

00-00=0: V/F Mode

Select the required V/F curve (01-00) based on your motor and application. Perform a stationary auto-tune (17-00=2). If the motor cable length is longer than 50m (165ft), see parameter 17-00 for details.

00-00=2: Sensorless Vector Control

Verify the inverter rating matches the motor rating. Perform rotational auto-tune to measure and store motor parameters for higher performance operation. Perform non-rotational auto-tune if it's not possible to rotate the motor during auto-tune. Refer to parameter group 17 for details on auto-tuning.

00-00=5: PM Sensorless Vector Control

Verify the inverter rating matches the motor rating. Set PM motor data in parameters 22-00 to 22-06. Refer to parameter 22-17 for details on PM Motor tuning. Stall prevention during deceleration is automatically disabled (08-00=xx1xb) when control mode is set to PMSLV. A braking resistor is recommended to be used to prevent the drive from tripping on over voltage due to regenerative energy. A braking module is required for Inverters ratings 230V 30HP, 460V/40HP or greater.

Note: Parameter 00-00 is not affected by drive initialization.

| 00-01 | Motor's Rotation Direction |
|-------|--|
| Range | 【0】 : Forward 【1】 : Reverse |

Use the FWD/REV key to change motor direction when Run Command Selection is set to keypad control (00-02 = 0). In keypad control motor direction is set by parameter 00-01. Motor direction is dependent on the motor direction lock selection parameter 11-00.

| 00-02 | Main Run Command Source Selection |
|-------|---|
| 00-03 | Alternative Run Command Source Selection |
| Range | 【0】 : Keypad control 【1】 : External terminal control 【2】 : Communication control 【3】 : PLC 【4】 : RTC |

Note: To switch the command source between the setting of main (00-02) and alternative (00-03) assign one of the DI (S1 to S6) to be the "Run Command Switch Over" (03-00~03-05=12).

00-02=0: Keypad Control

Use the keypad to start and stop the inverter and set direction with the forward / reverse key. Refer to section 4-1 for details on the keypad.

00-02=1: External Terminal Control

External terminals are used to start and stop the inverter and select motor direction. There are three different types: 2-wire and 3-wire operation and 2-wire self holding (latching) mode.

■ 2-wire operation

For 2-wire operation, set 03-00 (S1 terminal selection) to 0 and 03-01 (S2 terminal selection) to 1

| Terminal S1 | Terminal S2 | Operation |
|-------------|-------------|--|
| Open | Open | Stop Inverter |
| Closed | Open | Run Forward |
| Open | Closed | Run Reverse |
| Closed | Closed | Stop Inverter, Display EF9 Alarm after 500ms |

Parameter 13-08 to 2, 4 or 6 for 2-wire program initialization, multi-function input terminal S1 is set to forward , operation/ stop, and S2 is set for reverse, operation / stop.

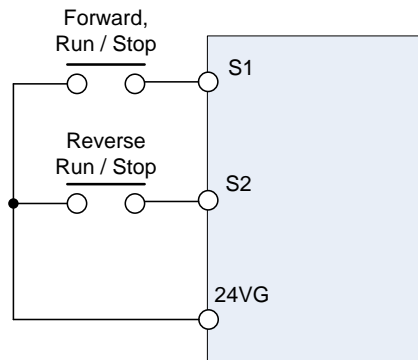

Figure 4.3.1 Wiring example of 2-wire

■ 3-wire operation

For 3-wire operation set any of parameters 03-02 to 03-05 (terminal S3 ~ S6) to 26 to enable 3-wire operation in combination with S1 and S2 terminals set to operation command and stop command.

Parameter 13-08 to 3, 5 or 7 for 3-wire program initialization, multi-function input terminal S1 is set to run operation, S2 for stop operation and S5 for forward/reverse command.

Note: Terminal S1 must be closed for a minimum of 50ms to activate operation.

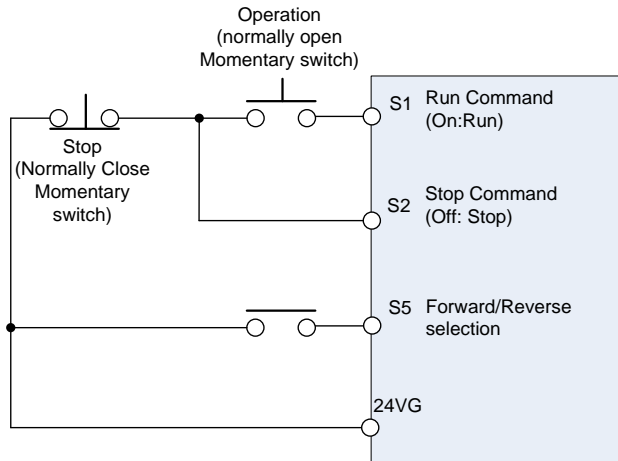

Figure 4.3.2 Wiring example of 3-wire

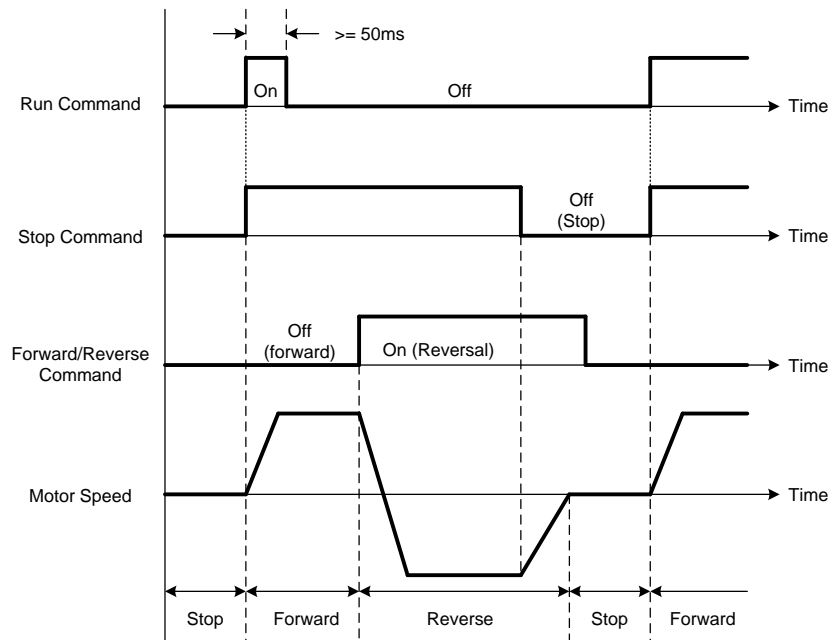
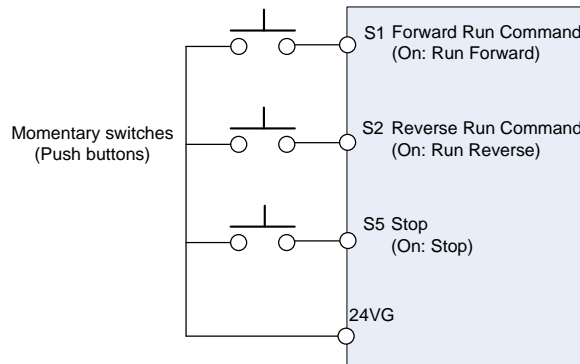

Figure 4.3.3 3-wire operation

■ **2-wire self holding (latching) operation**

Set one of parameters, 03-00 to 03-05 (terminal S1 ~ S6), to 53 in order to enable 2-wire self holding operation. After this mode is enabled, set terminal S1 (03-00=0) to forward and S2 (03-01=1) to reverse run command.



Note: Terminal S1, S2 and S5 must be closed for a minimum of 50ms to activate operation. The inverter will display SE2 error when input terminals S1-S6 is set to 53 and 26 simultaneously.

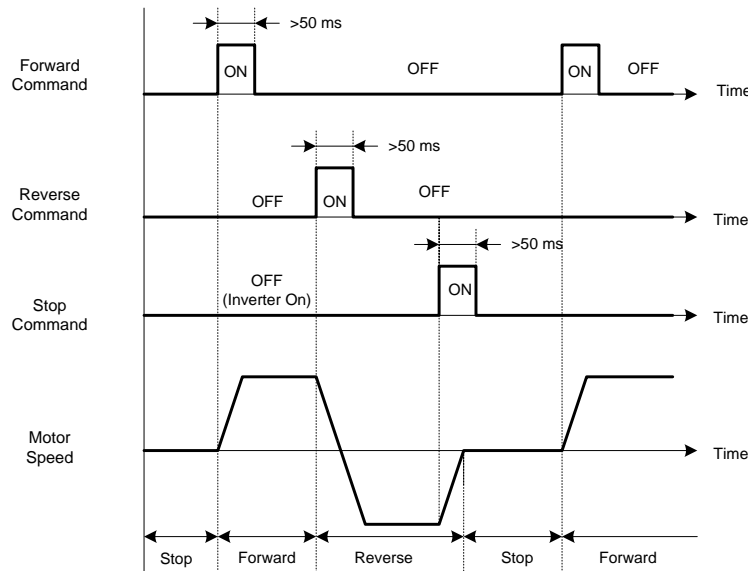

00-03=2: Communication control

The inverter is controlled by the RS-485 port. Refer to parameter group 9 for communication setup.

00-03=3: PLC control

The inverter is controlled by the inverter built-in PLC logic. Refer to section 4.3.

00-03=4: RTC control

The inverter is controlled by RTC timer when run command is set to RTC. Refer to function group 16.

| | |
|--------------|---|
| 00-04 | Language Selection (for LCD only) |
| Range | 【0】 : English 【1】 : Simple Chinese 【2】 : Traditional Chinese |

| | |
|--------------|--|
| 00-05 | Main Frequency Command Source Selection |
| 00-06 | Alternative Frequency Source Selection |
| Range | 【0】 : Keypad 【1】 : External control (Analog AI1) 【2】 : Terminal UP / DOWN 【3】 : Communication control 【4】 : Reserved 【5】 : Reserved 【6】 : RTC 【7】 : AI2 Auxiliary frequency |

00-05/00-06= 0: Keypad

Use the keypad to enter the frequency reference or by setting parameter 05-01 (frequency reference 1). Note that once the frequency command is switched to alternative frequency reference and 00-06 is set to 0, the frequency can be adjusted using parameter 05-01. Refer to section 4.1.4 for details.

00-05/00-06= 1: External control (Analog Input)

When 04-05=0, give frequency reference command from control circuit terminal AI1 (voltage input). If auxiliary frequency is used, refer to the multi-speed functions.

When frequency reference command is controlled by either AI1 or AI2, the following setup is required:

- ① 00-05/ 00-06 are set individually to be 1 and 7.
- ② Set AI2 signal type in 04-00 (AI1 is always 0~10V).
- ③ Set 04-05=0 (Auxiliary frequency setting).
- ④ Set multi-function terminal to be 13, then frequency reference command can be switched to AI1 control or AI2 control.

When 04-05=1, frequency reference command from control circuit terminal AI1 (voltage input) or AI2 (current input, set by 04-00).

Use AI1 terminal when voltage input signal is the main frequency reference command.

Use AI2 terminal when current input signal (4-20mA) is the main frequency reference command.

Use analog reference from analog input AI1 or AI2 to set the frequency reference (as shown in Figure 4.3.4). Refer to parameter 04-00 to select the signal type.

| | Voltage input | Current input | 04-00 Setting (Default = 1) | Dipswitch SW2 (Default 'V') | Remark Default 04-05="10" |
|-----------------------------|---------------|---------------|-----------------------------|-----------------------------|------------------------------|
| AI1 – Analog Input 1 | 0 ~ 10V | ----- | ----- | ----- | ----- |
| AI2 – Analog Input 2 | 0 ~ 10V | ----- | 0: AI2 0~10V | Set to 'V' | Set 04-05="10" (Note) |
| | ----- | 4 ~ 20mA | 1: AI2 4~20mA | Set to "I" | |

Note: Set parameter 04-05 to 10 to add frequency reference AI2 to AI1.

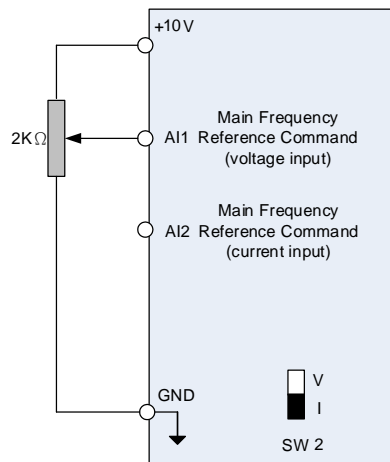

Figure 4.3.4 Analog input as main frequency reference command

00-05/00-06= 2: Terminal UP / DOWN

The inverter accelerates with the UP command closed and decelerates with the DOWN command closed. Please refer to parameter 03-00 ~ 03-05 for additional information.

Note: To use this function both the UP and DOWN command have to be set to any of the input terminals.

00-05/00-06= 3: Communication Control

The frequency reference command is set via the RS-485 communication port using the MODBUS RTU, BACnet or Metasys N2 protocol.

Refer to parameter group 9 for additional information.

00-05/00-06= 6: RTC (Real-time Clock)

Enables RTC control, reference frequency is controlled by the RTC function, refer to parameter group 16 for RTC setup.

00-05/00-06=7: AI2 Auxiliary frequency

When 04-05 is set to 0 (auxiliary frequency), frequency command is set by multi-function analog input AI2. Maximum output frequency (01-02, Fmax) =100%; if 04-05 is not set to 0, the frequency is 0. Refer to page 4-84 for multi-speed operation.

| 00-07 | Main and Alternative Frequency Command Modes |
|-------|--|
| Range | 【0】 : Main reference frequency 【1】 : Main frequency + alternative frequency |

When set to 0 the reference frequency is set by the main reference frequency selection of parameter 00-05. When set to 1 the reference frequency is sum of the main reference frequency (00-05) and alternative frequency (00-06).

Note: The inverter will display the SE1 error when 00-07 = 1 and parameter 00-05 and 00-06 are set to the same selection.

When parameter 00-06 is set to 0 (Keypad) the alternative frequency reference is set by parameter 05-01 (Frequency setting of speed-stage 0).

| 00-08 | Communication Frequency Command – READ ONLY |
|-------|---|
| Range | 【0.00~400.00】 Hz |

Display the frequency reference when 00-05 or 00-06 is set to communication control (3).

| 00-09 | Communication Frequency Command Memory |
|-------|---|
| Range | 【0】 : Do not store the communication frequency command at power down 【1】 : Store communication frequency reference at power down |

Note: This parameter is only effective when frequency reference is set via communication (00-05 / 00-06 = 3).

| | |
|--------------|--|
| 00-11 | Selection of PID Lower Limit Frequency |
| Range | 【0】 : PID minimum frequency is lower limit frequency when inverter sleeps. 【1】 : PID minimum frequency is 0Hz when inverter sleeps. |

00-11=0: PID minimum frequency is lower limit frequency (00-13).

00-11=1: PID minimum frequency is 0Hz

Note: Refer to parameters 10-17~10-20 for description of the sleep mode function.

| | |
|--------------|------------------------------|
| 00-12 | Upper Limit Frequency |
| Range | 【0.1~109.0】 % |

Set the maximum frequency reference as a percentage of the maximum output frequency. Maximum output frequency depends on motor selection.

Motor 1: Maximum frequency parameter 01-02.

Motor 2: Maximum frequency parameter 01-16.

| | |
|--------------|------------------------------|
| 00-13 | Lower Limit Frequency |
| Range | 【0.0~109.0】 % |

Set the minimum frequency reference as a percentage of the maximum output frequency. Maximum output frequency depends on motor selection. Motor 1: Maximum frequency is set by parameter 01-02 and Motor 2 Maximum frequency is set by parameter 01-16.

Notes:

- When the frequency lower limit is set to a value greater than 0 and the inverter is started the output frequency will accelerate to the frequency lower limit with a minimum frequency defined by parameter 01-08 for motor 1 and parameter 01-22 for motor 2.
- Frequency upper limit has to greater or equal to the frequency lower limit otherwise the inverter will display a SE01 (Set range error).
- Frequency upper and lower limit is active for all frequency reference modes.

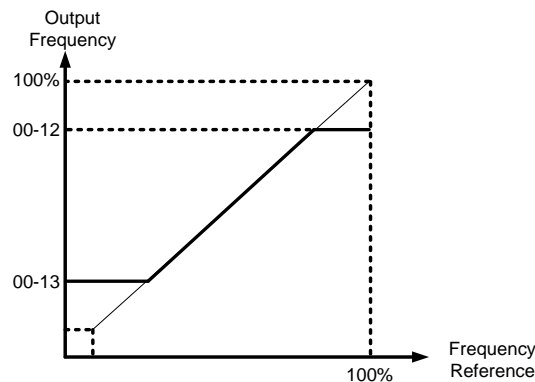

Figure 4.3.5 Frequency reference upper and lower limits

| | |
|-------|--|
| 00-14 | Acceleration Time 1 |
| Range | 【0.1~6000.0】 Sec |
| 00-15 | Deceleration Time 1 |
| Range | 【0.1~6000.0】 Sec |
| 00-16 | Acceleration Time 2 |
| Range | 【0.1~6000.0】 Sec |
| 00-17 | Deceleration Time 2 |
| Range | 【0.1~6000.0】 Sec |
| 00-21 | Acceleration Time 3 |
| Range | 【0.1~6000.0】 Sec |
| 00-22 | Deceleration Time 3 |
| Range | 【0.1~6000.0】 Sec |
| 00-23 | Acceleration Time 4 |
| Range | 【0.1~6000.0】 Sec |
| 00-24 | Deceleration Time 4 |
| Range | 【0.1~6000.0】 Sec |
| 00-25 | Switching Frequency of Acceleration and Deceleration |
| Range | 【0.00~400.00】 Hz 【0.0~1200.0】 Hz (When 00-31 = 1) |

Acceleration time is the time required to accelerate from 0 to 100% of maximum output frequency.
Deceleration time is the time required to decelerate from 100 to 0% of maximum output frequency.
Motor 1: Maximum frequency is set by parameter 01-02 and Motor 2 Maximum frequency is set by parameter 01-16.

Note: Actual acceleration and deceleration times can be affected by the inverter driven load.
The default values for the acceleration, deceleration times are dependent on the inverter size.

| Size | | Acceleration / Deceleration Default Value |
|------------|------------|--|
| 230V Class | 460V Class | |
| 5~15HP | 5~20HP | 10s |
| 20~30HP | 25~40HP | 15s |
| 40~175HP | 50~800HP | 20s |

A: Select acceleration and deceleration time via the digital input terminals

The following table shows the acceleration / deceleration selected when the digital input function Accel/Decel time 1 (#10) and Accel/Decel time 2 1(#30) are used.

Table 4.3.1 Acceleration / deceleration time selection

| Accel/dec1 time 2 (Set 03-00 ~ 03-05 = 30) | Accel/dec1 time 1 (Set 03-00 to 03-05 = 10) | Acceleration time | Deceleration time |
|---|--|----------------------|----------------------|
| 0 | 0 | Tacc1 (00-14) | Tdec1 (00-15) |
| 0 | 1 | Tacc2 (00-16) | Tdec2 (00-17) |
| 1 | 0 | Tacc3 (00-21) | Tdec3 (00-22) |
| 1 | 1 | Tacc4 (00-23) | Tdec4 (00-24) |

0: OFF, 1: ON

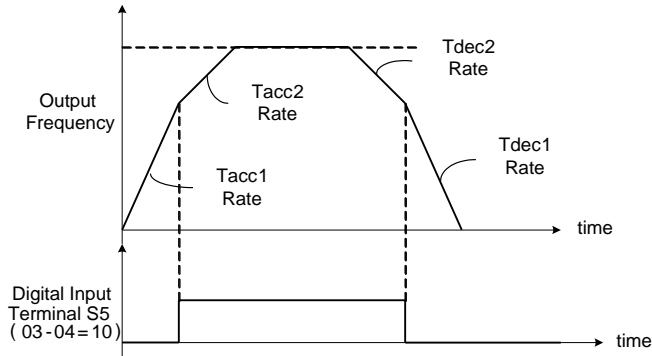

Figure 4.3.6: Terminal S5 switch between Tacc1/Tacc2 and Tdec1/Tdec2

B. Automatically acceleration / deceleration time switch-over based on output frequency

Set acceleration / deceleration switch over frequency parameter 00-25 to a value greater than 0 to automatically switch between Tacc1 (00-14) / Tdec1 (00-23) and Tacc4 (00-24) / Tdec4 (00-15).

Tacc1 (00-14) / Tdec1 (00-23) are active when the output frequency < 00-25 and Tacc4 (00-24) / Tdec4 (00-15) are active when the output frequency >= 00-25. Refer to the Figure 4.3.7 for details.

Note: Multi-function input function #10 (Accel/Decel time 1) and #30 (Accel/Decel time 2) have a higher priority than switch over frequency parameter 00-25.

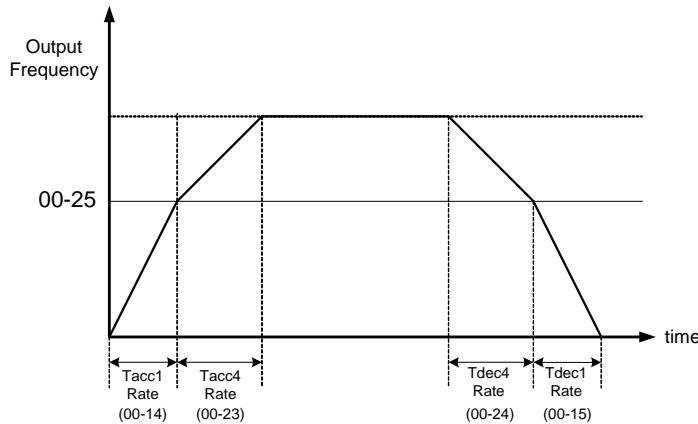

Figure 4.3.7 Automatic acceleration / deceleration time switch-over based on output frequency

| | |
|--------------|--|
| 00-18 | Jog Frequency |
| Range | 【0.00~400.00】 Hz 【0.0~1200.0】 Hz (When 00-31 = 1) |
| 00-19 | Jog Acceleration Time |
| Range | 【0.1~0600.0】 Sec |
| 00-20 | Jog Deceleration Time |
| Range | 【0.1~0600.0】 Sec |

Jog acceleration time (00-19) is the time required to accelerate from 0 to 100% of maximum output frequency. Jog deceleration time (00-20) is the time required to decelerate from 100 to 0% of maximum output frequency. Motor 1: Maximum frequency is set by parameter 01-02 and Motor 2 Maximum frequency is set by parameter 01-16.

The inverter uses the Jog frequency (00-18, default 6.0 Hz) as its frequency reference when jog is active.

| | |
|--------------|----------------------------|
| 00-26 | Emergency Stop Time |
| Range | 【0.0~6000.0】 Sec |

The emergency stop time is used in combination with multi-function digital input function #14 (Emergency stop). When emergency stop input is activated the inverter will decelerate to a stop using the Emergency stop time (00-26) and display the [EM STOP] condition on the keypad.

Note: To cancel the emergency stop condition the run command has to be removed and emergency stop input deactivated.

Multi-function digital input terminals (03-00 ~ 03-05) are set to 14: When the emergency stop input is activated the inverter will decelerate to a stop using the time set in parameter 00-26.

Note: After an emergency stop command the run command and emergency stop command have to be removed before the inverter can be restarted. Please refer to Figure 4.3.8. The emergency stop function can be used to stop inverter in case of an external event.

Multi-function digital input terminals (03-00 ~ 03-05) set to 15: When the base block input is activated the inverter output will turn off and the motor will coast to a stop.

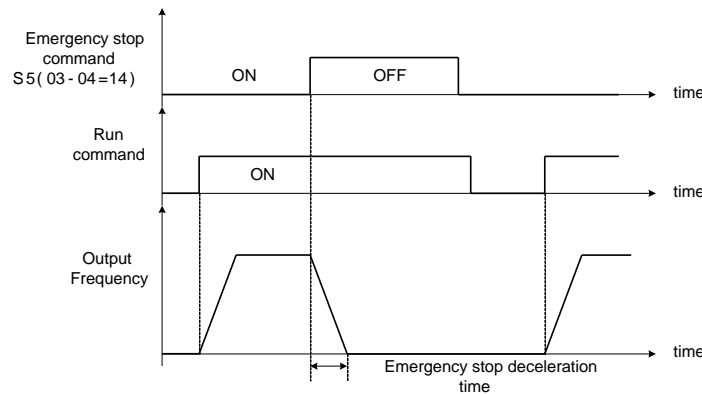

Figure 4.3.8 Emergency stop example

| | |
|--------------|--|
| 00-28 | Selection of Main Frequency Command Characteristic |
| Range | 【0】 : Positive characteristic (0~10V/4~20mA = 0~100%) 【1】 : Negative / inverse characteristic (0~10V/4~20mA = 100~0%) |

00-28= 0: Positive reference curve, 0 – 10V / 4 – 20mA = 0 – 100% main frequency reference.

00-28= 1: Negative reference curve, 0 – 10V / 4 – 20mA = 100 – 0% main frequency reference.

Note: Selection applies to analog input AI1 and AI2.

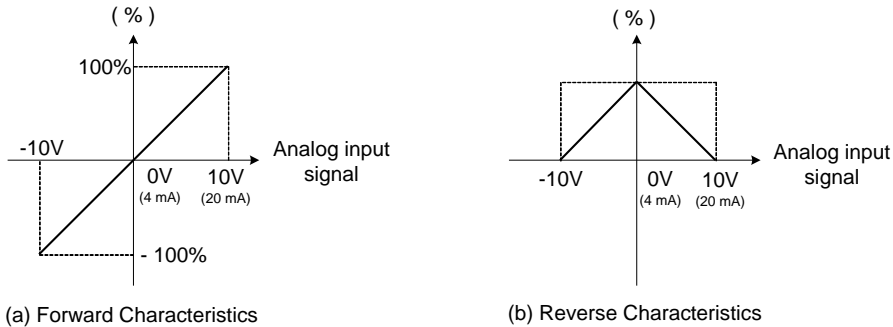

Figure 4.3.9 Positive/negative analog input as main frequency reference command.

| 00-32 | Application |
|-------|---|
| Range | 【0】 : Default Value 【1】 : Water supply pump 【2】 : Reserved 【3】 : Exhaust fan 【4】 : HVAC 【5】 : Compressor 【6】 : Reserved 【7】 : Reserved |

Note: If the setting value is changed to 0 (off), it performs 2-wire initialization (60Hz) (200/460V).

(1) Water supply pump

| Parameter | Name | Value |
|-----------|--------------------------------------|---|
| 00-00 | Control mode selection | 0 : V/F |
| 11-00 | Direction lock selection | 1 : Forward direction only |
| 07-00 | Momentary stop and restart selection | 1 : Enable |
| 08-00 | Stall prevention function | xx0xb : Stall prevention is enabled during deceleration |
| 23-00 | Function Selection | 1: Pump |

(3) Exhaust fan

| Parameter | Name | Value |
|-----------|--------------------------------------|---|
| 00-00 | Control mode selection | 0 : V/F |
| 11-00 | Direction lock selection | 1 : Forward direction only |
| 07-00 | Momentary stop and restart selection | 1 : Enable |
| 08-00 | Stall prevention function | xx0xb : Stall prevention is enabled during deceleration |

(4) HVAC

| Parameter | Name | Value |
|-----------|---------------------------------------|----------------------------|
| 00-00 | Control mode selection | 0 : V/F |
| 11-00 | Direction lock selection | 1 : Forward direction only |
| 11-01 | Carrier frequency | 8.0kHz |
| 07-00 | Momentary stop and restart selection | 1 : Enable |
| 11-03 | Automatic carrier frequency reduction | 1 : Enable |
| 23-00 | Function Selection | 2: HVAC |

(5) Compressor

| Parameter | Name | Value |
|-----------|--------------------------------------|---|
| 00-00 | Control mode selection | 0: V/F |
| 11-00 | Direction lock selection | 1: Forward direction only |
| 00-14 | Acceleration time 1 | 5.0 sec |
| 00-15 | Deceleration time 1 | 5.0 sec |
| 01-07 | Middle Output Voltage 1 | Half of the maximum voltage |
| 07-00 | Momentary stop and restart selection | 1: Enable |
| 08-00 | Stall prevention function | xx0xb: Stall prevention during deceleration |
| 23-00 | Function Selection | 3: Compressor |

| 00-33 | Modified Parameters (LCD Keypad Only) |
|-------|---|
| Range | 【0】 : Disable 【1】 : Enable |

This parameter automatically lists all the modified parameters. When set to enable (1), all modified parameter in the advanced mode are shown and can be edited directly. To hide modified parameter overview set parameter 00-33 to 0. This function can display up to 250 modified parameters. If more than 250 parameters are modified only the first 250 will be displayed.

Example: Modify parameter 00-03 (Alternative Run Command Source Selection).

| Steps | LCD Display | Descriptions |
|-------|---|---|
| 1 | Group 00 Basic Func. 01 V/F Pattern 02 Motor Parameter | The starting parameter group (00) in the setting modes of ▲ (Up)/ ▼ (Down) selection groups. |
| 2 | PARA 00 -01. Motor Direction -02. RUN Source -03. Sub RUN Source | Press READ/ ENTER key and ▲ (Up)/ ▼ (Down) to select alternative run command source (00-03). |
| 3 | Edit 00-00 Sub RUN Source █ Terminal (0 ~4) <2> | Press READ/ ENTER key and adjust the value. The selected setting value will flash. |
| 4 | PARA 00 -33. Modify parameter -41. User P1 -42. User P2 | Press DSP/ FUN to select modified parameters (00-33). |
| 5 | Edit 00-33 Modify parameter █ Enable (0 ~1) <0> | Press READ/ ENTER key and value to 1 (Modified parameter overview is enabled.) The selected setting value will flash. |
| 6 | Modify 00 00-03. Sub RUN Source 00-33. Modify parameter | Press DSP/ FUN back to the advanced modes. |

■ **User Parameter Setting (00-41 ~ 00-56) (LCD Keypad)**

| | |
|--------------|---|
| 00-41 | User Parameter 0 Function Setting |
| 00-42 | User Parameter 1 Function Setting |
| 00-43 | User Parameter 2 Function Setting |
| 00-44 | User Parameter 3 Function Setting |
| 00-45 | User Parameter 4 Function Setting |
| 00-46 | User Parameter 5 Function Setting |
| 00-47 | User Parameter 6 Function Setting |
| 00-48 | User Parameter 7 Function Setting |
| 00-48 | User Parameter 8 Function Setting |
| 00-50 | User Parameter 9 Function Setting |
| 00-51 | User Parameter 10 Function Setting |
| 00-52 | User Parameter 11 Function Setting |
| 00-53 | User Parameter 12 Function Setting |
| 00-54 | User Parameter 13 Function Setting |
| 00-55 | User Parameter 14 Function Setting |
| 00-56 | User Parameter 15 Function Setting |

- User parameter (00-41 ~ 00-56) can be used to create a custom parameter list. Select up to 16 parameters from parameters 01-00 to 24-06.
- When the parameter 13-06 is set to 1 or 2, the custom parameter list 00-41 ~ 00-56 can be changed.
- The customer parameter list 00-41 ~ 00-56 can only be changed in the advanced modes while the drive is not running.
- To exit the user parameter menu, press RESET key followed by the DSP/FUN key to select parameter Group 13.

Example 1: Set 03-00 (Multi-function terminal Function Setting-S1) to user parameter 0 (00-41)

| Steps | LCD Display | Descriptions |
|-------|---|---|
| 1 | Group 00 Basic Func. 01 V/F Pattern 02 Motor Parameter | Select the start parameter group (00) in the advanced modes. |
| 2 | PARA 00 -41. User P0 -42. User P1 -43. User P2 | Press (READ/ ENTER) key and ▲ (Up) / ▼ (Down) to select user parameter 0 (00-41). |
| 3 | Edit 00-41 User P0=00-41 00-41 User P0 <00-01 - 24-07> | Press (READ/ ENTER) key to edit parameter 00-41. * The selected setting value will flash. |
| 4 | Edit 00-41 User P0=00-41 03-00 S1 Function Sel <00-01 - 24-07> | Press ◀ (Left) / ▶ (Right) and ▲ (Up) / ▼ (Down) key to select parameter 03-00 (Multi-function terminal Function Setting-S1) |
| 5 | Edit 00-41 User P0= 03-00 03-00 S1 Function Sel <00-01 - 24-07> | Press (READ/ ENTER) key to save parameter 00-41 set to 03-00. Digit stops flashing and displays shows User P0 = 03-00 ; (Multi-function terminal Function Setting-S1) has now been added to the user parameter list (00-41). |
| 6 | Monitor Freq Ref 12-16=000.00Hz ----- 12-17=000.00Hz 12-18=0000.0A | Press (DSP/ FUN) key to the display main screen. If the BACK key is not pressed within one minute, the screen will automatically revert back to the monitor mode as shown here to the left. The time to revert back to the monitor mode can be set with parameter 16-06. |

Example 2: After one or more user parameters in 00-41 ~ 00-56 are set, user parameters settings are as follows.

| Step | LCD Display | Descriptions |
|------|--|---|
| 1 | Group 13 Driver Status 14 PLC Setting 15 PLC Monitor | Select the start parameter group (03) in the advanced mode. |
| 2 | PARA 13 -06. Access Level -07. Password 1 -08. Initialize | Press (READ/ ENTER) and ▲ (Up) / ▼ (Down) key to select access level parameter (13-06). |
| 3 | Edit 13-06 Access Level ----- 1 User Level (0~2) < 2 > | Press (READ/ ENTER) key to edit access level (13-06). * The selected setting value will flash. |
| 4 | —ADV— G01-02 Access Level 1 User Level (0-2) < 2 > | Press ▲ (Up) / ▼ (Down) key to change setting to 1 (13-06=1, user level) and press (READ/ ENTER) key to save the setting, After 13-06 has been set the digit stops flashing and the screen shows the modified value. A few seconds later, the selected digit will flash again. User level (13-06=1) displays one or more parameters set in the user parameters of 00-41 ~ 00-56. If no user parameters are set, 13-06 cannot be set to a value of 1. When user level is selected only group 00 User functions and group 13 Driver status are available. |
| 5 | PARA 13 -06. Access Level | Press (DSP/FUN) key exit edit mode. |
| 6 | Group 00.User Function | Press (DSP/FUN) key to go back to the parameter group selection. Use ▲ (Up) key to select Group 00 User Function. |
| 7 | Monitor Freq Ref 12-16=000.00Hz ----- 12-17=000.00Hz ----- 12-18=0000.0A | Press (DSP/ FUN) key to go back to the main screen. To exit user parameter menu, press RESET key and DSP/FUN key to select parameter Group 13. |
| 8 | Group 00. User Function00 U 13.Driver Status | Only parameter 13-06 can be modified together with group 00 to edit user parameters. |

| | | |
|----|--|---|
| 9 | PARA -41. S1 Function Sel 00 | Press (READ/ ENTER) key and ▲ (Up) / ▼ (Down) key to select user parameter 0 (00-41) display. |
| 10 | Edit 00-41 S1 Function Sel <hr/> 00 FJOG (00~57) < 00 > < 03-00 > | Press (READ/ ENTER) key to enter edit mode for parameter 00-41. *The selected setting value will flash. In this example, 03-00 (Multi-function terminal Function Setting S1) has been set as a user parameter (00-41). The original parameter group of the user parameter is shown on the display on the bottom right. |
| 11 | Edit 00-41 S1 Function Sel <hr/> 00 2-Wire (FWD-RUN) (00~57) < 00 > < 03-00 > | Press ▲ (Up) / ▼ (Down) key to change the value of parameter 03-00 to 2. Use (READ/ ENTER) key to save the new value to 0041 and 03-00. The new value stops flashing when the new value has been saved successfully. |
| 12 | Monitor Freq Ref 12-16=000.00Hz ----- 12-17=000.00Hz ----- 12-18=0000.0A | Press (DSP/FUN) key exit to the main screen. If DSP/ FUN key is not pressed within one minute, , the screen will automatically revert back to the monitor mode as shown here to the left. The time to revert back to the monitor mode can be set with parameter 16-06. |

User Parameter Run Mode Structure

- A. Parameters in Group 0~24 can be set as user parameters except parameter 00-00 and 00-41~00-56.

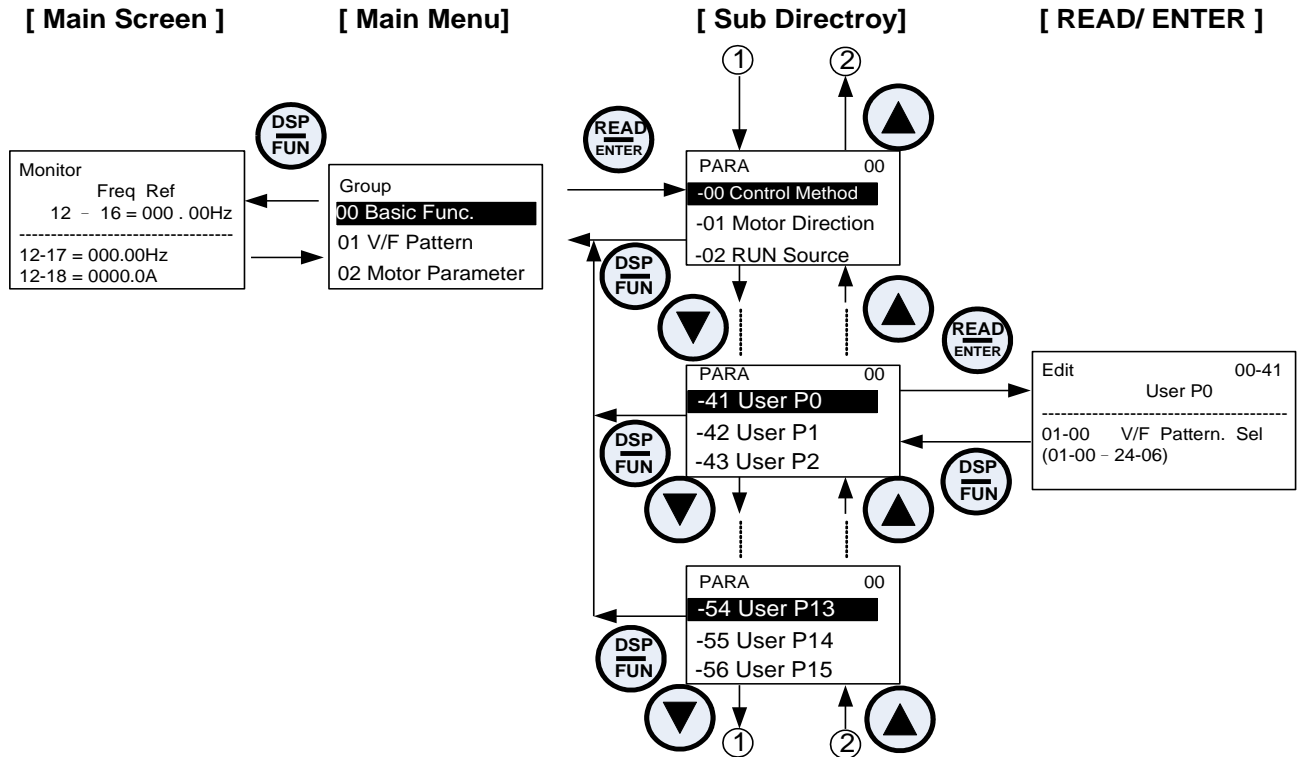

Note: When 13-06=1 (User level) only parameters defined by the user parameters of 00-41 ~ 00-56 are shown.

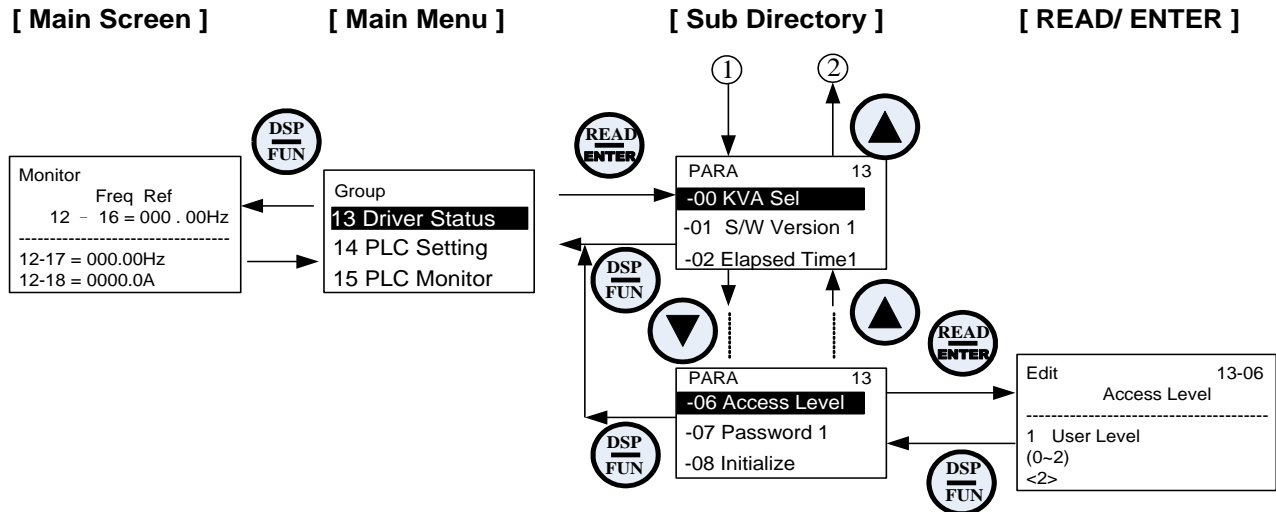

| |
|--|
| Group 01-V/F Control Parameters |
|--|

| | |
|--------------|----------------------------|
| 01-00 | V/F Curve Selection |
| Range | 【0~FF】 |

The V/F curve selection is enabled for V/F mode. Make sure to set the inverter input voltage parameter 01-14.

There are three ways to set V/F curve:

- (1) 01-00 = 0 to E: choose any of the 15 predefined curves (0 to E).
- (2) 01-00 = 0F, use 01-02~01-09 and 01-12 ~ 01-13, with voltage limit.
- (3) 01-00 = FF: use 01-02~01-09 and 01-12 ~ 01-13, without voltage limit.

The default parameters (01-02 ~ 01-09 and 01-12 ~ 01-13) are the same when 01-00 is set to F (default) and 01-00 is set to 1.

Parameters 01-02 ~ 01-13 are automatically set when any of the predefined V/F curves are selected.

This parameter will be affected to reset by the initialization parameter (13-08).

Consider the following items as the conditions for selecting a V/F pattern.

- (1) The voltage and frequency characteristic of motor.
- (2) The maximum speed of motor.

Table 4.3.2: 5 - 30HP V/F curve selection

| Type | Specification | 01-00 | V/F curve [†] | Type | Specification | 01-00 | V/F [†] | | |
|--------------------------------|---------------|-------------------|------------------------|-----------------------------------|---------------|-------|----------------------|-------|---|
| General purpose | 50Hz | 0 | | High Starting Torque [‡] | 50Hz | 8 | | | |
| | | | | | | | | | |
| | 60Hz | 60Hz Saturation | 1 F | | | 60Hz | Low Starting Torque | A | |
| | | 50Hz Saturation | 2 | | | | High Starting Torque | B | |
| Variable Torque Characteristic | 50Hz | Variable Torque 1 | 4 | Constant-power torque(Reducer) | 90Hz | C | | | |
| | | | | | | | Variable Torque 2 | 5 | |
| | 60Hz | Variable Torque 3 | 6 (Def. Val.) | | | 120Hz | D | | |
| | | Variable Torque 4 | 7 | | | | | 180Hz | E |

[‡]Select high starting torque only for the following conditions.

- (1) The power cable length is > 150m (492ft).
- (2) Voltage drop at startup is high.
- (3) An AC reactor is used on the input side or output side of the inverter.
- (4) Motor power lower than the inverter rated power.

| Type | Specification | 01-00 | V/F curve ^{*1} | | | | | | | | | | |
|--|---------------|-------|--|----------------|-------------|---|-----|-----|----|-----|-----|------|-----|
| Rated Horsepower Torque (Reducer) | 1200Hz | F | <p>The graph shows a V/F curve with the following data points:</p> <table border="1"> <thead> <tr> <th>Frequency (Hz)</th> <th>Voltage (V)</th> </tr> </thead> <tbody> <tr> <td>0</td> <td>7.5</td> </tr> <tr> <td>200</td> <td>55</td> </tr> <tr> <td>800</td> <td>200</td> </tr> <tr> <td>1200</td> <td>200</td> </tr> </tbody> </table> | Frequency (Hz) | Voltage (V) | 0 | 7.5 | 200 | 55 | 800 | 200 | 1200 | 200 |
| Frequency (Hz) | Voltage (V) | | | | | | | | | | | | |
| 0 | 7.5 | | | | | | | | | | | | |
| 200 | 55 | | | | | | | | | | | | |
| 800 | 200 | | | | | | | | | | | | |
| 1200 | 200 | | | | | | | | | | | | |

*1. Values shown are for 230V class inverters; double the values for 460V class inverters.

Table 4.3.3: 40HP and above V/F curve selection

| Type | Specification | 01-00 | V/F curve ^{*1} | Type | Specification | 01-00 | V/F curve ^{*1} | | | | |
|--------------------------------|---------------|-------------------|-------------------------|-----------------------------------|---------------|-------|-------------------------|---|-------|---|--|
| General purpose | 50Hz | 0 | | High Starting Torque [‡] | 50Hz | 8 | | | | | |
| | | | | | | | | | | | |
| | 60Hz | 2 | | | 60Hz | A | | | | | |
| | | | | | | | B | | | | |
| Variable Torque Characteristic | 72Hz | 3 | | Constant-power torque(Reducer) | 90Hz | C | | | | | |
| | | | 50Hz | | | | 4 | 5 | 120Hz | D | |
| | | | | | | | Variable Torque 2 | | | | |
| | 60Hz | 6 (Def. Val.) | 7 | | 180Hz | E | | | | | |
| | | Variable Torque 3 | | | | | | | | | |
| | | Variable Torque 4 | | | | | | | | | |

*1. Values shown are for 230V class inverters; double the values for 460V class inverters.

‡Select high starting torque only for the following conditions.

- (1) The power cable length is > 150m (492ft).
- (2) Voltage drop at startup is high.
- (3) An AC reactor is used on the input side or output side of the inverter.
- (4) Motor power lower than the inverter rated power.

| | |
|--------------|--|
| 01-02 | Maximum Output Frequency |
| Range | 【20.0~400.0】 Hz |
| 01-03 | Maximum Output Voltage |
| Range | 230V: 【0.1~255.0】 V 460V: 【0.2~510.0】 V |
| 01-04 | Middle output frequency 2 |
| Range | 【0.0~400.0】 Hz |
| 01-05 | Middle Output Voltage 2 |
| Range | 230V: 【0.0~255.0】 V 460V: 【0.0~510.0】 V |
| 01-06 | Middle Output Frequency 1 |
| Range | 【0.0~400.0】 Hz |
| 01-07 | Middle Output Voltage 1 |
| Range | 230V: 【0.0~255.0】 V 460V: 【0.0~510.0】 V |
| 01-08 | Minimum Output Frequency |
| Range | 【0.0~400.0】 Hz |
| 01-09 | Minimum Output Voltage |
| Range | 230V: 【0.0~255.0】 V 460V: 【0.0~510.0】 V |
| 01-12 | Base Frequency |
| Range | 【10.0~400.0】 Hz |
| 01-13 | Base Output Voltage |
| Range | 230V: 【0.0~255.0】 V 460V: 【0.0~510.0】 V |

V/F curve setting (01-02 ~ 01-09 and 01-12 ~ 01-13)

Select any of the predefined V/F curves setting '0' to 'E' that best matches your application and the load characteristic of your motor, choose a custom curve setting 'F' or 'FF' to set a custom curve.

Important:

Improper V/F curve selection can result in low motor torque or increased current due to excitation.

For low torque or high speed applications, the motor may overheat. Make sure to provide adequate cooling when operating the motor under these conditions for a longer period of time.

If the automatic torque boost function is enabled (parameter 01-10), the applied motor voltage will automatically change to provide adequate motor torque during start or operating at low frequency.

Custom V/F Curve Setting:

A custom curve selection allows users to set parameters 01-02 ~ 01-13 whereas a predefined curve selection does not.

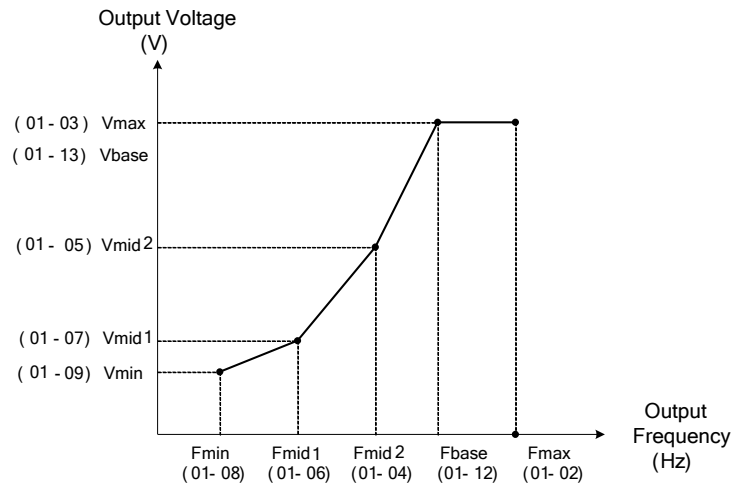

Figure 4.3.10 Custom V/F curve

When setting the frequency related parameters for a custom V/F curve values make sure that:

$$F_{\max} > F_{\text{base}} > F_{\text{mid2}} > F_{\text{mid1}} > F_{\min}$$

(01-02) (01-12) (01-04) (01-06) (01-08)

The 'SE03' V/F curve tuning error is displayed when the frequency values are set incorrectly.

When 01-04 and 01-05 (or 01-18 and 01-09) are set to 0, the inverter ignores the set values of Fmin2 and Vmin2.

When the control mode is changed parameter 00-00, 01-08 (F_{\min}) and 01-09 (V_{\min}) will automatically be changed to the default setting of the selected control mode.

SLV (Sensorless vector control)

Enter the motor data in parameter group 17 for SV and SLV control mode (00-00) and perform auto-tuning.

In the SLV mode the V/F curve normally does not have to be re-adjusted after a successful auto-tune.

The maximum output frequency setting 01-02 (F_{\max}), base frequency 01-12 (F_{base}) or minimum output frequency 01-08 (F_{\min}) can be adjusted but the voltage is automatically adjusted by the internal current controller.

Set the base frequency (01-12, F_{base}) to the motor rated frequency on the motor nameplate.

Perform the auto-tuning procedure after adjusting parameters 02-19 or 17-04 to reduce the voltage at no-load operation.

Motor jitter can be reduced by lowering the no-load voltage. Please note that lowering the no-load voltage increases the current at no-load.

| | |
|--------------|---------------------------------|
| 01-10 | Torque Compensation Gain |
| Range | 【0.0~2.0】 |

In V/F mode the inverter automatically adjusts the output voltage to adjust the output torque during start or during load changes based on the calculated loss of motor voltage.

The rate of adjustment can be changed with the torque compensation gain parameter.

Refer to the torque compensation gain adjustment shown in Figure 4.3.11.

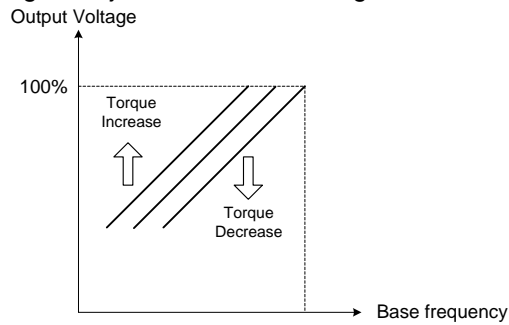

Figure 4.3.11 Torque compensation gain to increase/decrease output torque

Increase value when:

- The wiring between the inverter and the motor is too long
- The motor size is smaller than the inverter size

Note: Gradually increase the torque compensation value and make sure the output current does not exceed inverter rated current.

Reduce value when:

- When experiencing motor vibration

Important:

Confirm that the output current at low speed does not exceed the rated output current of the inverter.

| | |
|--------------|--|
| 01-11 | Selection of Torque Compensation Mode |
| Range | 0: Torque Compensation Mode 0 1: Torque Compensation Mode 1 |

01-11=0: General torque compensation mode.

01-11=1: High-speed torque compensation mode (120~160Hz).

Torque compensation level decreases when the frequency increases. Compensation for range 0~120Hz is the same as torque compensation mode 0.

| | |
|--------------|--|
| 01-14 | Input Voltage Setting |
| Range | 230V: 【155.0~255.0】 V 460V: 【310.0~510.0】 V |

Sets the inverter input voltage (E.g. 230V / 208V / 230V / 240V or 380V / 415V / 440V / 460V / 480V).

This parameter is used as a reference for predefined V/F curve calculation (01-00 = 0 to E), over-voltage protection level, stall prevention, etc...

| | |
|--------------|---------------------------------|
| 01-15 | Torque Compensation Time |
| Range | 【0~10000】 ms |

Sets the torque compensation delay time in milliseconds.

Only adjust in the following situations:

Increase value when:

- When experiencing motor vibration

Decrease value when:

- When motor torque response is too slow

| | |
|-------------------------------------|--|
| Group 02: IM Motor Parameter | |
|-------------------------------------|--|

| | |
|--------------|--|
| 02-00 | No-load Current |
| Range | 【0.01~600.00】 A |
| 02-01 | Rated Current |
| Range | V/F mode is 10%~200% of inverter's rated current. SLV mode is 25%~200% of inverter's rated current. |
| 02-03 | Rated Rotation Speed |
| Range | 【0~60000】 rpm |
| 02-04 | Rated Voltage |
| Range | 230V: 【50.0~240.0】 V 460V: 【100.0~480.0】 V |
| 02-05 | Rated Power |
| Range | 【0.01~600.00】 KW |
| 02-06 | Rated Frequency |
| Range | 【10.0~400.0】 Hz |
| 02-07 | Poles |
| Range | 【2~16】 (Even) |
| 02-09 | Excitation Current |
| Range | 【15.0~70.0】 % |
| 02-10 | Core Saturation Coefficient 1 |
| Range | 【1~100】 % |
| 02-11 | Core Saturation Coefficient 2 |
| Range | 【1~100】 % |
| 02-12 | Core Saturation Coefficient 3 |
| Range | 【80~300】 % |
| 02-13 | Core Loss |
| Range | 【0.0~15.0】 % |
| 02-15 | Resistance between Wires |
| Range | 【0.001~60.000】 Ω |
| 02-19 | No-Load Voltage |
| Range | 230V: 【50~240】 V 460V: 【100~480】 V |
| 02-33 | Leakage Inductance Ratio |
| Range | 【0.1~15.0】 % |
| 02-34 | Slip Frequency |
| Range | 【0.1~20.0】 Hz |

In most case no adjustment is required after performing an auto-tune except when using the inverter in special applications (e.g. machine tool, positioning, etc...).

Please refer to parameter group 22 for permanent magnet motor parameters.

- (1) Number of motor poles (02-07)
Set the number of motor pole according to the motor nameplate.

- (2) Motor rated power (02-05)
Set the motor power according to the motor nameplate.
- (3) Motor rated current (02-01)
Set the motor rated current according to the motor nameplate.
- (4) Motor rated voltage (02-04)
Set the motor rated voltage according to the motor nameplate.
- (5) Rated frequency of motor (02-06)
Set the motor rated frequency according to the motor nameplate.
- (6) Rated rotation speed of motor (02-03)
Set the motor rpm according to the motor nameplate.

(7) No-load motor voltage (02-19)

Parameter determines the rated flux during motor's rated rotation in SLV control mode. Set the value of this parameter to the same value as parameter 17-08 (02-19 for motor 2). A value of 10~50V below the input voltage level ensures that the motor is capable of providing adequate torque performance when operating at nominal speed (or higher speed). Setting the value to small can result in a reduction in no-load current, weakened motor flux and an increase in motor current while the motor is loaded.

(8) Motor excitation current (02-09)

- This parameter is automatically set via auto-tuning. It required manual adjustment without auto-tuning.
- Start tunig from 33% when doing manual adjustment. If the output value of no-load voltage (12-67) is higher than the setting value of no-load voltage (17-08), the motor excitation current is adjusted downward; if the value (12-67) is lower than the value (17-08), the motor excitation current is adjusted upward.
- Adjust the value of motor excitation current (02-09) will change the value of the motor leakage inductance (02-17) and motor mutual inductance (02-18).

(9) Setting of motor core saturation coefficients 1, 2 and 3 (02-10, 02-11, 02-12)

These parameters are automatically set during auto-tune. No adjustment required. Parameters are set to 50% for 02-10, 75% for 02-11 and 137.5% for 02-12 to reduce the impact of core saturation. The motor core's saturation coefficient is defined as a percentage of the motor excitation current. When the motor flux reaches 137.5% level, the core's saturation coefficient shall be greater than 137.5%. When the motor flux is 50% or 75%, the core's saturation coefficient is required to be less than 50% and 75%.

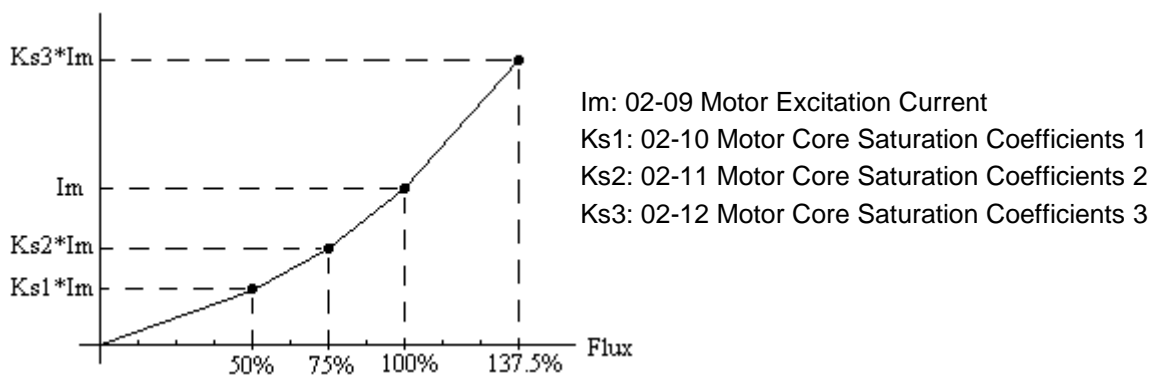

Figure 4.3.12-a Y-equivalent model of an induction motor

(10) Motor core loss (02-13)

Set motor core loss as the percentage of the motor rated power.

$$\% W_{\text{core}} (02-13) = \frac{3 \times \text{Motor core loss (watt)}}{\text{Motor rated power (watts, 02-05)}} \times 100\%$$

Note: In V/F mode motor core loss (02-13) is used to for torque compensation.

(11) Motor line to line resistance (02-15)

(12) Motor no-load current (02-00).

Value is calculated based on the motor rated frequency (17-05) and motor rated current (17-03).

In V/F control mode, the output current is greater than the no-load current with slip compensation is enabled.

Note: The value of 02-01 needs to be greater than the value set in parameter 02-00, otherwise warning message "SE01" out of range error will be displayed.

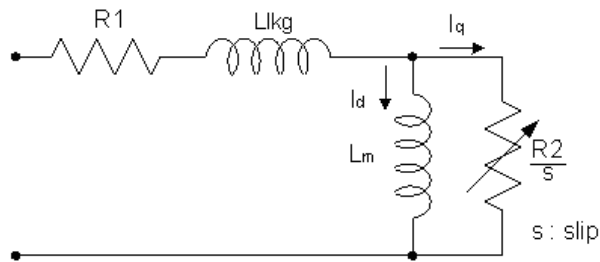

Figure 4.3.12-b Y-equivalent model of an induction motor

(13) Motor Leakage Inductance Ratio (02-33)

- This parameter is set by the conversion of manual adjustment function. This adjustment does not have the magnetic function. Normally, it does not require adjustment.
- Definition of leakage inductance ratio is the ratio of leakage inductance to rotor inductance. If default setting is 3.4%, adjust this ratio changes the parameter of motor leakage inductance. The formula of this ratio is as follows:

$$\xi = \frac{LlKg}{Lr}$$

- When the ratio of leakage inductance is too high or too low, it may cause the motor jittering with different sound and without operation. The general setting range is 3.0%~5.0% and 4.0% is the relatively common value for motor operation normally. The ratio of leakage inductance is adjusted depending on different motor types.

(14) Motor Slip Frequency (02-34)

- This parameter is set by the conversion of manual adjustment function. This adjustment does not have the magnetic function. Normally, it does not require adjustment.
- The default setting is 1Hz and the value of motor slip frequency is obtained from motor nameplate. Take 4-pole motor with 60Hz for example,

Synchronous speed is $N = \frac{120 \times \text{Frequency}}{\text{Pole}} = \frac{120 \times 60}{4} = 1800 \text{ rpm}$ and the rated speed in the motor

nameplate is 1700 rpm, then $\text{Slip} = \frac{1800 - 1700}{60} = 1.67 \text{ Hz}$.

Note: Adjusting the motor slip frequency changes the parameter of rotor resistance and the value of slip frequency is adjusted depending on different motor types.

Group 03: External Digital Input and Output Parameters

| | |
|--------------|--|
| 03-00 | Multi-function terminal function setting – S1 |
| 03-01 | Multi-function terminal function setting – S2 |
| 03-02 | Multi-function terminal function setting – S3 |
| 03-03 | Multi-function terminal function setting – S4 |
| 03-04 | Multi-function terminal function setting – S5 |
| 03-05 | Multi-function terminal function setting – S6 |
| Range | <p> 【0】 : 2-Wire Sequence (ON: Forward Run Command) 【1】 : 2-Wire Sequence (ON: Reverse Run Command) 【2】 : Multi-Speed Setting Command 1 【3】 : Multi-Speed Setting Command 2 【4】 : Multi-Speed Setting Command 3 【5】 : Multi-Speed Setting Command 4 【6】 : Forward Jog Run Command 【7】 : Reverse Jog Run Command 【8】 : UP Frequency Increasing Command 【9】 : DOWN Frequency Decreasing Command 【10】 : Acceleration/ Deceleration Setting Command 1 【11】 : Inhibit Acceleration/ Deceleration Command 【12】 : Main/Alternative Run command Switching 【13】 : Main/Alternative Frequency Command Switching 【14】 : Emergency Stop (Decelerate to Zero and Stop) 【15】 : External Baseblock Command (Rotation freely to Stop)^{*1} 【16】 : PID Control Disable 【17】 : Fault Reset (RESET) 【18】 : Reserved 【19】 : Speed Search 1(from the maximum frequency)^{*1} 【20】 : Manual Energy Saving Function 【21】 : PID Integral Reset 【22】 ~ 【23】 : Reserved 【24】 : PLC Input 【25】 : External Fault 【26】 : 3-Wire Sequence (Forward/ Reverse Command) 【27】 : Local/ Remote Selection 【28】 : Remote Mode Selection 【29】 : Jog Frequency Selection 【30】 : Acceleration/ Deceleration Setting Command 2 【31】 : Inverter Overheating Warning 【32】 : Reserved 【33】 : DC Braking^{*1} 【34】 : Speed Search 2 (from Frequency Command)^{*1} 【35】 : Timing Function Input 【36】 : PID Soft Start Disable 【37】 ~ 【40】 : Reserved 【41】 : PID Sleep 【42】 ~ 【46】 : Reserved 【47】 : Fire Mode (Forced to Run Mode) 【48】 : KEB Acceleration 【49】 : Parameters Writing Allowable </p> |

- 【50】 : Unattended Start Protection (USP)**
- 【51】 ~ 【52】 : Reserved**
- 【53】 : 2-Wire Self Holding Mode (Stop Command)**
- 【54】 : Switch PID1 and PID2**
- 【55】 : RTC Time Enable**
- 【56】 : RTC Offset Enable**
- 【57】 : Forcing Frequency Run**
- 【58】 : Run Permissive Function**

*1: Selections 15, 19, 33, and 34 are not available in PM motor control mode.

Refer to the multi-function digital input and related parameters in the following Fig. 4.3.13

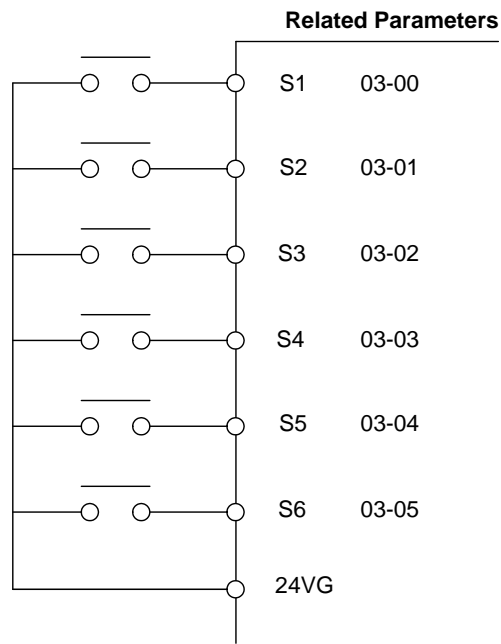

Figure 4.3.13 Multi-function digital input and related parameters

Table 4.3.4 Multi-function digital input setting (03-00 ~ 03-05) (“O”: Enable, “X”: Disable)

| Value | Function | | Description | Control mode | | |
|-------|--|----------------------------|--|--------------|-----|--------|
| | Name | LCD Display | | V/F | SLV | PM SLV |
| 0 | 2-wire type (Forward operation) | 2-Wire (FWD-RUN) | 2- wire (ON : Forward operation command). | ○ | ○ | ○ |
| 1 | 2-wire type (Reverse operation) | 2-Wire (REV-RUN) | 2- wire (ON : Reverse operation command). | ○ | ○ | ○ |
| 2 | Multi-Speed Setting Command 1 | Muti-Spd Ref 1 | Multi-Speed Reference 1 | ○ | ○ | ○ |
| 3 | Multi-Speed Setting Command 2 | Muti-Spd Ref 2 | Multi-Speed Reference 2 | ○ | ○ | ○ |
| 4 | Multi-Speed Setting Command 3 | Muti-Spd Ref 3 | Multi-speed Reference 3 | ○ | ○ | ○ |
| 5 | Multi-Speed Setting Command 4 | Muti-Spd Ref 4 | Multi-speed Reference 4 | ○ | ○ | ○ |
| 6 | Forward Jog Run Command | FJOG | ON: Forward operation in jog mode (00-18) | ○ | ○ | ○ |
| 7 | Reverse Jog Run Command | RJOG | ON: Reverse operation in jog mode (00-18) | ○ | ○ | ○ |
| 8 | UP Frequency Increasing Command | UP command | ON: Command of output frequency increasing (only used by support of DOWN command). | ○ | ○ | ○ |
| 9 | DOWN Frequency Decreasing Command | DOWN command | ON: Command of output frequency decreasing (only used by support of UP command). | ○ | ○ | ○ |
| 10 | Acceleration/Deceleration Setting Command 1 | Acc/Decel Time Selection 1 | Acceleration/deceleration time selection command1 | ○ | ○ | ○ |
| 11 | Inhibit Acceleration/Deceleration Command | ACC/DEC Inhibit | ON: Acceleration/deceleration prohibition | ○ | ○ | ○ |
| 12 | Main/Alternative Run command Switching | Run Change Sel | Run command source is set by alternative run command (00-03). | ○ | ○ | ○ |
| 13 | Main/Alternative Frequency Command Switching | Freq Change Sel | Frequency command source is set by alternative frequency command (00-06). | ○ | ○ | ○ |
| 14 | Emergency Stop (Decelerate to Zero and Stop) | E-Stop | ON: Emergency stop input | ○ | ○ | ○ |
| 15 | External Baseblock Command (Rotation freely to Stop) | Ext. BB | ON: Inverter base interdiction | ○ | ○ | ○ |
| 16 | PID Control Disable | PID Disable | ON: PID control disable | ○ | ○ | ○ |
| 17 | Fault Reset | Fault Reset | Fault reset | ○ | ○ | ○ |
| 18 | Reserved | Reserved | Reserved | - | - | - |
| 19 | Speed Search 1(from the maximum frequency) | Speed Search 1 | ON: Search the speed from the maximum output frequency | ○ | ○ | ○ |
| 20 | Manual Energy Saving Function | Energy saving | ON: Manual energy saving control is based on the settings of 11-12 and 11-18. | ○ | X | ○ |
| 21 | PID Integral Reset | PID I-Reset | ON: PID integral value reset | ○ | ○ | ○ |
| 22~23 | Reserved | Reserved | Reserved | - | - | - |
| 24 | PLC input | PLC Input | ON: Digital PLC input | ○ | ○ | ○ |
| 25 | External fault | Ext. Fault | ON: External fault alarm | ○ | ○ | ○ |

| Value | Function | | Description | Control mode | | |
|-------|--|----------------------------|---|--------------|-----|--------|
| | Name | LCD Display | | V/F | SLV | PM SLV |
| 26 | 3-Wire Sequence (Forward/ Reverse Command) | 3-Wire (FWD/REV) | 3-wire control (forward/reverse command). ON: Reverse; OFF: Forward. When the parameter is set to 26, terminal S1 and terminal will become operation command and stop command respectively, and their original functions will be closed. | ○ | ○ | ○ |
| 27 | Local/ Remote Selection | Local/Remote | ON: Local mode (via the digital operator) OFF: Frequency command and operation command will be determined according to the setting of parameter (00-02 and 00-05) | ○ | ○ | ○ |
| 28 | Remote Mode Selection | Remote Mode Sel | ON: RS-485 communication OFF: Control circuit terminal | ○ | ○ | ○ |
| 29 | Jog Frequency Selection | JOG Freq Ref | ON: Selection jog frequency command | ○ | ○ | ○ |
| 30 | Acceleration/ Deceleration Setting Command 2 | Acc/Decel Time Selection 2 | Acceleration/deceleration time selection command2 | ○ | ○ | ○ |
| 31 | Inverter Overheating Warning (OH2) | Overheat Alarm | ON: Inverter overheat alarm (OH2) input(will display OH2) | ○ | ○ | ○ |
| 32 | Reserved | Reserved | Reserved | - | - | - |
| 33 | DC Braking | DC Brake Command | ON: Perform DC braking | ○ | ○ | ○ |
| 34 | Speed Search 2 (from Frequency Command) | Speed Search 2 | ON: Search speed from set frequency | ○ | ○ | ○ |
| 35 | Timing Function Input | Timer Input | .Set the time function at 03-33, 03-34 .Set the time function output at 03-11, 03-12 | ○ | ○ | ○ |
| 36 | PID Soft Start Disable | PID SFS Disable | ON: PID slow-start off | ○ | ○ | ○ |
| 37~40 | Reserved | Reserved | Reserved | - | - | - |
| 41 | PID Sleep | PID Sleep | ON: PID Sleep | ○ | ○ | ○ |
| 42~46 | Reserved | Reserved | Reserved | - | - | - |
| 47 | Fire Mode (Forced to Run Mode) | Fire Mode | ON: Turn off hardware and software fault or alarm protection (a special application of HVAC) | ○ | ○ | ○ |
| 48 | KEB Acceleration | KEB Accel. | ON: KEB acceleration start | ○ | X | X |
| 49 | Parameters Write-in Allowed | Write Enabled | ON: All parameters are writable. OFF: Except reference frequency (00-05) all parameters are write-protected. | ○ | ○ | ○ |
| 50 | Unattended Start Protection (USP) | USP | ON: After power is input, the inverter ignores the operation command OFF: After power is input, the inverter will return the operation status before power is cut off. | ○ | ○ | ○ |
| 51~52 | Reserved | Reserved | Reserved | - | - | - |
| 53 | 2-Wire Self Holding Mode (Stop Command) | 2-Wire (STOP) | 2-Wire Self Holding Mode (ON: Stop Command). | ○ | ○ | ○ |
| 54 | Switch PID1 and PID2 | PID 2 Enable | ON: PID1 enabled OFF: PID2 enabled | ○ | ○ | ○ |

| Value | Function | | Description | Control mode | | |
|-------|-------------------------|--------------------|--|--------------|-----|--------|
| | Name | LCD Display | | V/F | SLV | PM SLV |
| 55 | RTC Time Enable | RTC Timer Switch | ON:RTC Time Function Enabled | ○ | ○ | ○ |
| 56 | RTC Offset Enable | Offset Time Switch | ON:RTC Offset Enabled | ○ | ○ | ○ |
| 57 | Forcing Frequency Run | Force Freq Cmd | ON: Run on Forcing Frequency (23-28) OFF: Determine frequency reference and run command depending on the setting of parameter (00-02 and 00-05) | ○ | ○ | ○ |
| 58 | Run Permissive Function | Safety Function | ON: Stop on the setting of 08-30 | ○ | ○ | ○ |

03-0X =00: 2-wire control: forward operation

03-0X =01: 2-wire control: reverse operation. Refer to the 2-wire operation mode in Figure 4.3.1.

03-0X =02: Multi-speed setting command 1.

03-0X =03: Multi-speed setting command 2.

03-0X =04: Multi-speed setting command 3.

03-0X =05: Multi-speed setting command 4.

03-0X =29: Jog frequency selection (setting =29).

Select frequency reference using the multi-function digital input.

Table 4.3.5 Multi-speed operation selection

| Speed | Multi-function digital input (S1 ~ S6) ^{*3} | | | | | Frequency selection |
|-------|--|-------------------------|-------------------------|-------------------------|-------------------------|--|
| | Jog frequency reference | Multi-speed frequency 4 | Multi-speed frequency 3 | Multi-speed frequency 2 | Multi-speed frequency 1 | |
| 1 | 0 | 0 | 0 | 0 | 0 | Frequency command 1 (05-01) or main speed frequency ^{*2} |
| 2 | 0 | 0 | 0 | 0 | 1 | Auxiliary speed frequency or frequency reference 2 (06-01) |
| 3 | 0 | 0 | 0 | 1 | 0 | Frequency command 3 (06-02) |
| 4 | 0 | 0 | 0 | 1 | 1 | Frequency command 4 (06-03) |
| 5 | 0 | 0 | 1 | 0 | 0 | Frequency command 5 (06-04) |
| 6 | 0 | 0 | 1 | 0 | 1 | Frequency command 6 (06-05) |
| 7 | 0 | 0 | 1 | 1 | 0 | Frequency command 7 (06-06) |
| 8 | 0 | 0 | 1 | 1 | 1 | Frequency command 8 (06-07) |
| 9 | 0 | 1 | 0 | 0 | 0 | Frequency command 9 (06-08) |
| 10 | 0 | 1 | 0 | 0 | 1 | Frequency command 10 (06-09) |
| 11 | 0 | 1 | 0 | 1 | 0 | Frequency command 11(06-10) |
| 12 | 0 | 1 | 0 | 1 | 1 | Frequency command 12 (06-11) |
| 13 | 0 | 1 | 1 | 0 | 0 | Frequency command 13 (06-12) |
| 14 | 0 | 1 | 1 | 0 | 1 | Frequency command 14(06-13) |
| 15 | 0 | 1 | 1 | 1 | 0 | Frequency command 15 (06-14) |
| 16 | 0 | 1 | 1 | 1 | 1 | Frequency command 16 (06-15) |
| 17 | 1 ^{*1} | — | — | — | — | Jog frequency command (00-18) |

0: OFF, 1: ON, —: Ignore

*1. Jog frequency terminal has a higher priority than multi-speed reference 1 to 4.

*2. When parameter 00-05=0 (frequency reference input = digital operator), multi-speed frequency 1 will be set by 05-01 frequency reference setting1). When parameter 00-05=1 (frequency reference input=control circuit terminal), multi-speed frequency command 1 is input through analog command terminal AI1 or AI2).

*3. Multi-speed operation is disabled when PID is enabled.

Wiring Example: Fig. 4.3.14 and 4.3.15 show an example of a 9-speed operation selection.

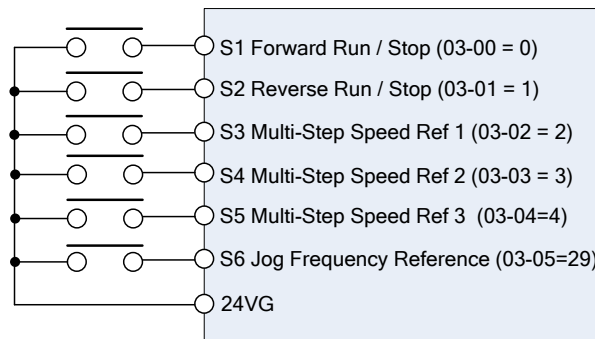

Figure 4.3.14 Control Terminal Wiring Example

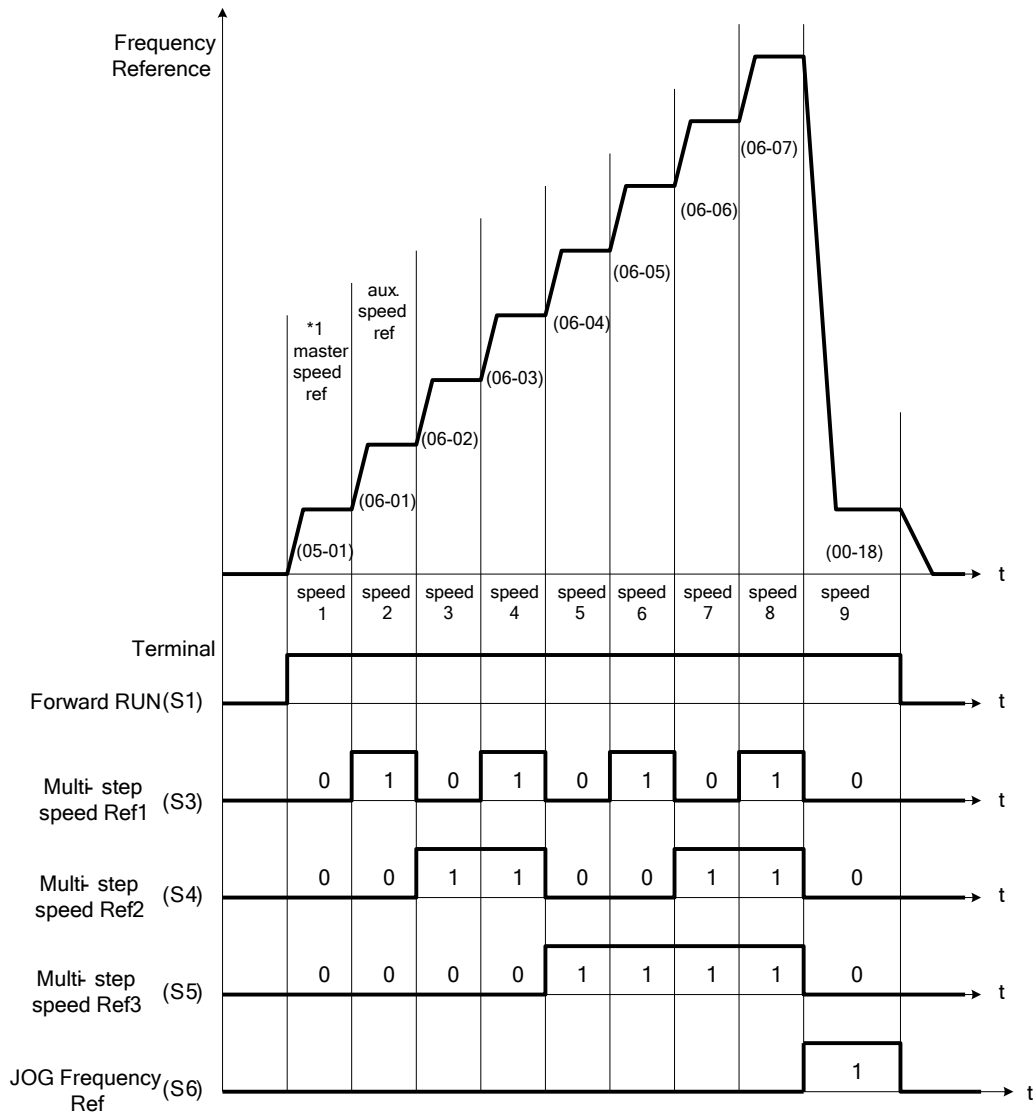

Figure 4.3.15 9-speed timing diagram

*1. When 00-05=1, multi-speed frequency reference is set by analog input AI1 or AI2.

03-0X =06: Forward jog run command, uses jog frequency parameter 00-18.

Notes:

- Jog command has a higher priority than other frequency reference commands.
- Jog command uses stop mode set in parameter 07-09 when Jog command is active > 500ms.

03-0X =07: Reverse jog run command, uses jog frequency parameter 00-18.

Notes:

- Jog command has a higher priority than other frequency reference commands.
- Jog command uses stop mode set in parameter 07-09 when Jog command is active > 500ms.

03-0X =08: UP frequency command; set parameter 00-05 Frequency command to 2 to activate. Refer to parameter 11-56 for UP/DOWN mode.

03-0X =09: Down frequency command; set parameter 00-05 Frequency command to 2 to activate. Refer to parameter 11-56 for UP/DOWN mode.

Note: UP/DOWN frequency command follows standard acceleration and deceleration times Tacc1 / Tdec1 (00-14, 00-15) or Tacc2 / Tdec 2 (00-16, 00-17) and requires both UP and DOWN functions 08 and 09 to be programmed to the digital input terminals.

Note: SE02 DI terminal Error will be displayed when:

- When only the UP or DOWN command function is programmed to the digital inputs.
- When both UP and DOWN command are activated simultaneously.

For the examples of UP/DOWN control wiring and operation, please refer to Figure 4.3.16 and 4.3.17.

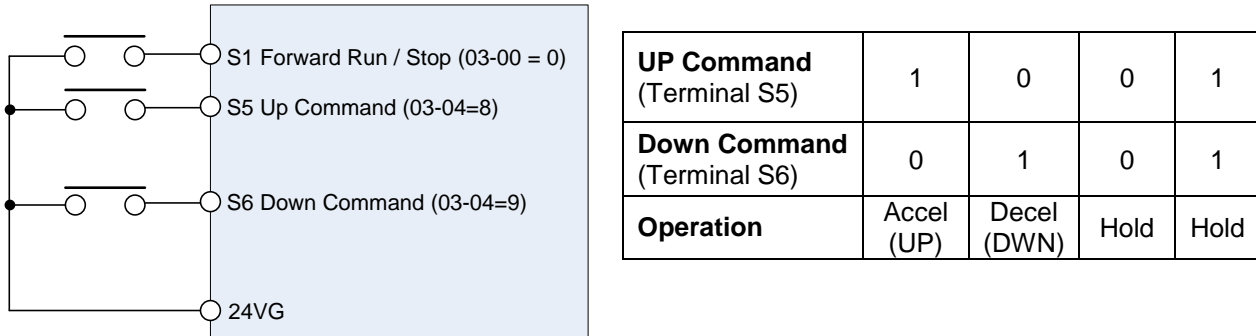

Figure 4.3.16 UP/DOWN wiring and operation example

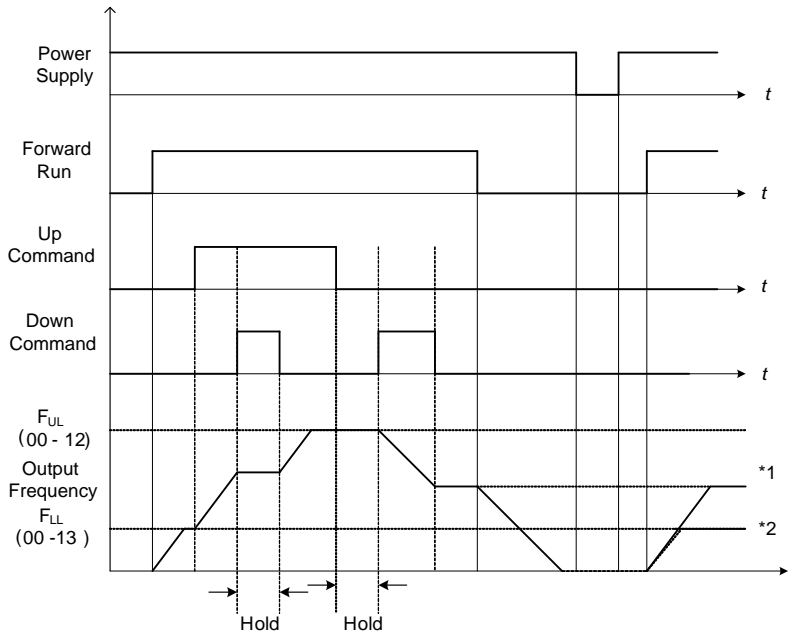

Figure 4.3.17 Up / Down command timing diagram

UP / DOWN Command Operation

When the Forward Run command is active and the UP or Down command is momentarily activated the inverter will accelerate the motor up to the lower limit of the frequency reference (00-13).

When using the UP / Down command, the output frequency is limited to the upper limit of frequency reference (00-12) and the lower limit of frequency reference (00-13).

The UP / DOWN command uses acceleration 1 or 2 / deceleration time 1 or 2 for normal operation Tacc1 / Tdec1 (00-14, 00-15) or Tacc2 / Tdec 2 (00-16, 00-17).

Refer to 03-40 UP/ DOWN frequency width setting for using other functions of UP/ DOWN.

Frequency reference retention is active when parameter 11-58 is set to 1 and the frequency reference is saved when power is lost and retrieved when power is restored.

- (1). When 11-58 = 1 and the operation command is active, the output frequency will accelerate to the previously stored frequency command.
- (2). When 11-58 = 0 and the operation command is active, the output frequency will accelerate to the lower limit of frequency reference (00-13).

03-0X =10: Acceleration/deceleration 1 selection

03-0X =30: Acceleration/deceleration 2 selection

Refer to the "multi-function digital input terminals select acceleration/ deceleration time" in Table 4.3.1 and Figure 4.3.6.

03-0X =11: Inhibit acceleration/deceleration command (hold command)

When activated suspends the acceleration / deceleration operation and maintains the output frequency at current level.

If 11-58 = 1, the frequency reference value is saved when the acceleration/deceleration inhibit command is active. Deactivating the acceleration / deceleration inhibit command resumes acceleration / deceleration.

If 11-58 = 0, the frequency reference value is saved when the acceleration/deceleration inhibit command is active and even when powering down the inverter.

Refer to Fig.4.3.18. for example.

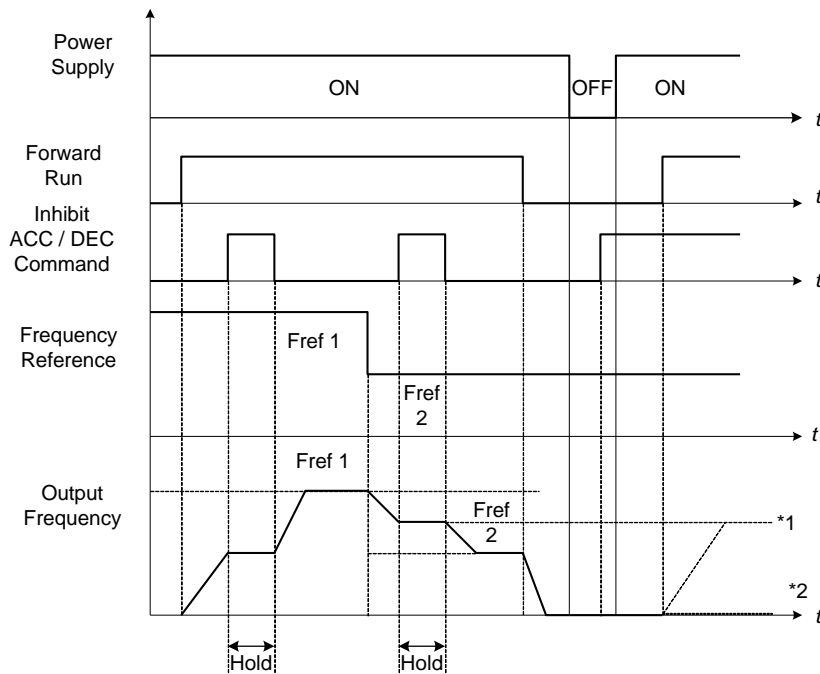

Figure 4.3.18 Inhibit acceleration / deceleration command operation

*1. When 11-58 = 1, and acceleration / deceleration inhibit command is activated, the frequency reference is stored even when powering down the inverter. When a run command is given (e.g. run forward) and the acceleration / deceleration inhibit command is active, the inverter will accelerate to the previously stored frequency reference.

*2. When 11-58 = 0, and a run command is and the acceleration / deceleration inhibit command is active, the frequency reference and output frequency will remain at zero.

03-0X =12: Main/Alternative Run command Switching

Run command source is set by alternative run command (00-03) when function terminal is active. When function terminal is set to 27 (Local/ Remote control selection), the priority will higher than the switch of main/ alternative run command.

03-0X =13: Main/Alternative Frequency Command Switching

Frequency command source is set by alternative frequency command (00-06) when function terminal is active. When function terminal is set to 27 (Local/ Remote control selection), the priority will higher than the switch of main/ alternative frequency command.

03-0X =14: Emergency stop (decelerate to zero and stop)

Refer to the "deceleration time of emergency stop" of parameter 00-26.

03-0X =15: External Baseblock Command (coast to stop)

Execute the base block command by the use of ON / OFF way of multi-function digital input terminal, and prohibit the inverter output.

During run: When an external base block command is activated, the keypad displays "BBn BaseBlock (Sn)", indicating the inverter output is turned off (n indicates the digital input number 1 – 6). Upon removing the base block signal, the motor will run at the frequency reference. If speed search from frequency reference is active the inverter output frequency starts from the frequency reference and searches for the coasting motor speed and continue to operate. If speed search is not active the output frequency starts at 0Hz.

During deceleration: When an external base block command is activated, the keypad displays "BBn BaseBlock (Sn)", indicating the inverter output is turned off (n indicates the digital input number 1 – 6). Upon removing the base block signal, the motor is stopped or will coast to a stop and the inverter will remains in the stop condition.

During acceleration: When an external base block command is activated, the keypad displays "BBn BaseBlock (Sn)", indicating the inverter output is turned off (n indicates the digital input number 1 – 6). Upon removing the base block signal, the motor will run at the frequency reference. If speed search from frequency reference is active the inverter output frequency starts from the frequency reference and searches for the coasting motor speed and continue to operate. If speed search is not active the output frequency starts at 0Hz.

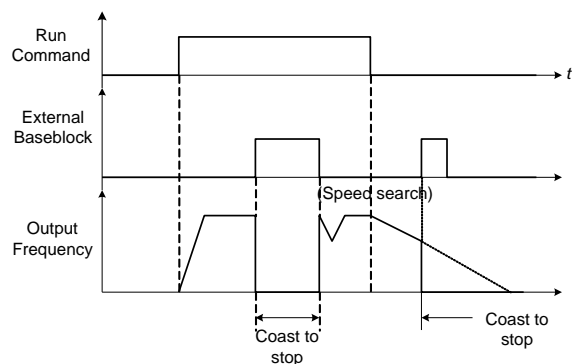

Figure 4.3.19 External base block operation

03-0X =16: PID control disable.

03-0X =17: Fault reset

The output becomes active when the inverter trips on a fault. Upon an inverter fault the inverter output will turn off (base block) and the keypad displays the dedicated fault message.

When fault occurs, the following actions can be used to reset the fault:

1. Program one of the multi-function digital inputs (03-00 to 03-05) to 17 (reset fault) and active input.*
2. Press the reset key of the digital operator (RESET).*
3. Recycle power to the inverter. **Important Note:** If a run command is active during power-up, the inverter will start running automatically.

* To reset an active fault the run command has to be removed.

03-0X =19: Speed Search 1 (from the maximum frequency).

03-0X =34: Speed Search 2 (from the frequency command).

Refer to the "speed search" function in the parameter group 7 (start/ stop control function).

03-0X =20: Energy saving enabled

Manual energy savings function is set with parameters 11-12 and 11-18.

For the manual energy saving operation refer to Figure 4.3.78.

03-0X =21: PID integral reset

03-0X =25: External fault

Activating the external fault input will turn off the inverter output and the motor will coast to a stop. The keypad displays the external fault message "EFn Ext. Fault (Sn)", where n is the input terminal number.

03-0X =27: Local / Remote control selection.

Switch between Local (keypad) or Remote (control circuit terminals or RS485) frequency reference. Use parameter 00-05 (Main frequency command source selection) and 00-02 (Run command selection) to select the input source. When PID is enabled (10-03=XXX1), parameter 10-00 (target value source) is used. If 23-00=1, make sure to set the value of parameter 23-04. If 23-00=2, make sure to set the value of parameter 00-02 and 23-59.

Note: In 3-wire operation terminal S1 and S2 are reserved for run/stop operation and the Local / Remote function can only be set to digital input terminals S3 to S6 (03-02 to 03-05).

Note: To switch between local and remote the inverter has to be stopped.

| Input | Mode | Frequency Reference / Run/Stop Command Source |
|-------|--------|--|
| ON | Local | - Frequency reference and Run-Stop from keypad. - LEDs SEQ and REF are off. - When PID is enabled, REF indicator OFF, PID target value is set by the keypad. |
| OFF | Remote | - Frequency reference source selected by parameter 00-05 and Run-Stop source selected by parameter 00-02. - LEDs SEQ and REF are on. - When PID is enabled, REF indicator ON, PID target value is set by control terminal AI1. |

03-0X =28: Remote mode selection

Switch between terminal source and communication (RS-422/RS-485) source for frequency reference and operation command.

In Remote mode, indicators of SEQ and REF are on; Use terminals AI1 and AI2 to control the frequency command and terminals S1, S2 or communication terminal RS-485 to control the operation command.

| Input | Mode | Frequency Reference / Run/Stop Command Source |
|-------|---------------|--|
| ON | Communication | - Frequency reference and run/stop command control via communication (RS-422/RS-485). |
| OFF | Terminal | - Frequency reference source from AI1 / AI2 input (00-05=1) and Run-Stop command from terminals S1 / S2 (00-02=1). |

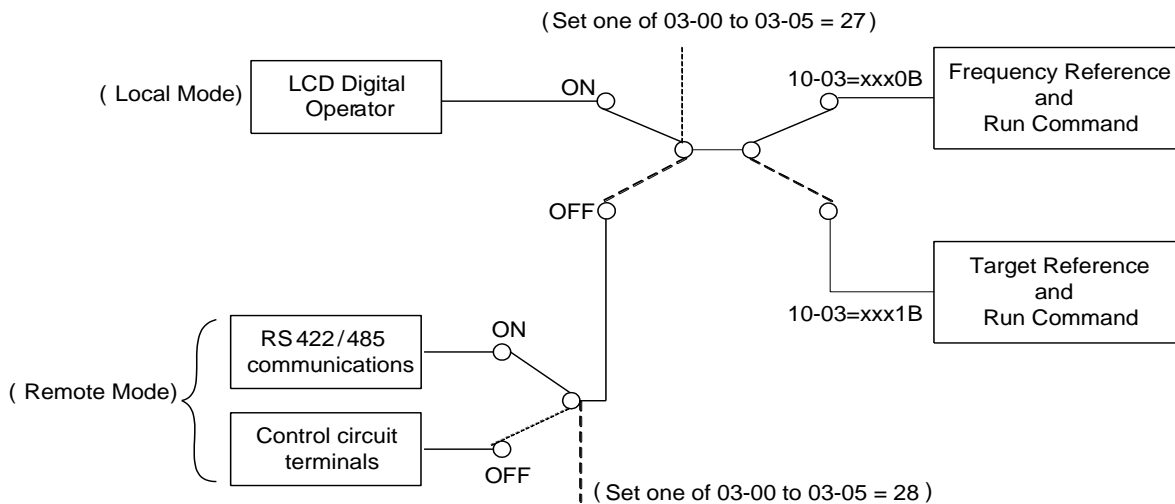

Figure 4.3.20 Remote mode operation selection

To switch the frequency reference and operation command input between communication RS-485 and control terminals the following parameters have to be set:

1. 00-05=1 (use control terminal AI1 or AI2 as reference frequency source)
2. 00-02=1 (use control terminal S1 or S2 for operation command)
3. Set one of the digital input terminals (03-02 to 03-05) to 28 (Operation selection of remote mode)

03-0X =24: PLC Input

Input is used for the PLC ladder logic. Ladder diagram can be modified using the F510 TECO Link software.

03-0X =26: 3-Wire Sequence (Forward/ Reverse Command)

When the digital input terminals (S3~S6) is set to 26, terminal S1 and S2 will become the run command and stop command. Refer to Fig.4.3.2.

03-0X =29: Jog Frequency Selection

When 00-18 (Jog Frequency) is set up, the inverter depends on this frequency for command when it is ON.

03-0X =30: Acceleration/ Deceleration Setting Command 2

When it is ON, the inverter will be active depends on the acceleration time 2 of 00-16 and deceleration time 2 of 00-17.

03-0X =31: Inverter overheat warning

When input is active the inverter displays warning message "OH2" and continues operation. Deactivating the input reverts back to the original display. Warning message does not require resetting the inverter.

03-0X =33: DC braking

When input is active DC-Injection braking is enabled during start and stopping of the inverter. DC Injection braking is disabled when a run or jog command is active. Refer to the DC braking time diagram in Fig.4.3.21.

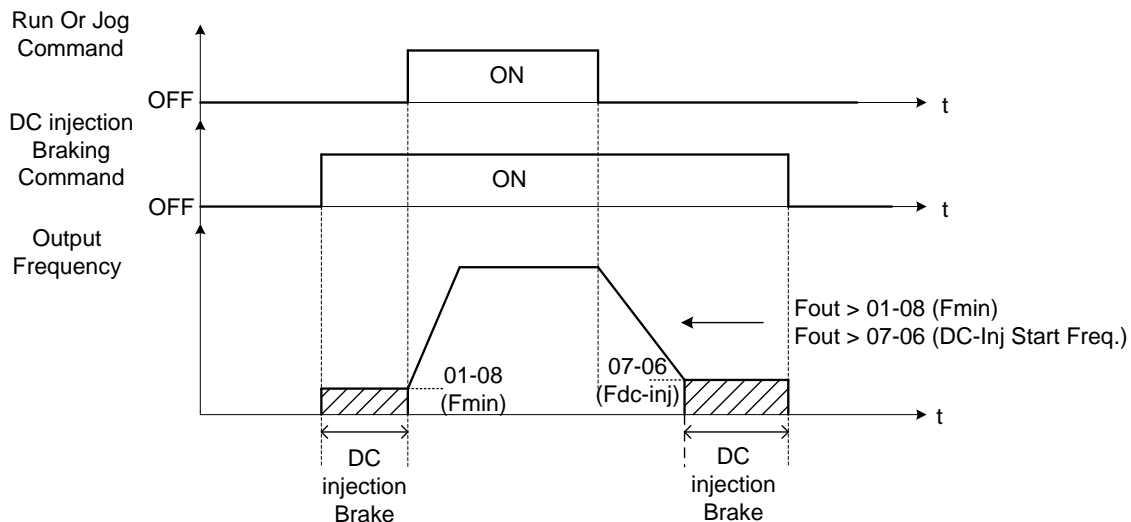

Figure 4.3.21 DC braking timing diagram

03-0X =35: Timing function

Refer to the "time function" parameter 03-37 and 03-38.

03-0X =36: PID Soft start disable

Refer to the "PID Control" function of PID function parameter group 10.

03-0X =47: Fire mode (Forced operation mode)

When input is active the inverter disables all warnings and hardware protection except SC. This function is commonly used in commercial applications where the inverter controls an exhaust fan and needs run until destruction in case of a fire.

03-0X =48: KEB acceleration

When input is active enables KEB (Kinetic Energy Braking) during acceleration. Refer to the parameter description of 11-47 and 11-48. Note: To enable set parameter 11-47 to a value greater than 0.

03-0X =49: Parameters write-in allowed

When input is active allows parameter to be changed.

Note: When none of the digital input terminals are set to function 49, parameter write-in protection is controlled by parameter 13-06.

| Input | Parameter Save |
|-------|----------------------------|
| ON | Parameters Write Enabled |
| OFF | Parameters Write Protected |

03-0X =50: Unattended Start Protection (USP)

When input is active prevents inverter from starting automatically when a run command is present at time of power-up. Please refer to Fig.4.3.21a for more details.

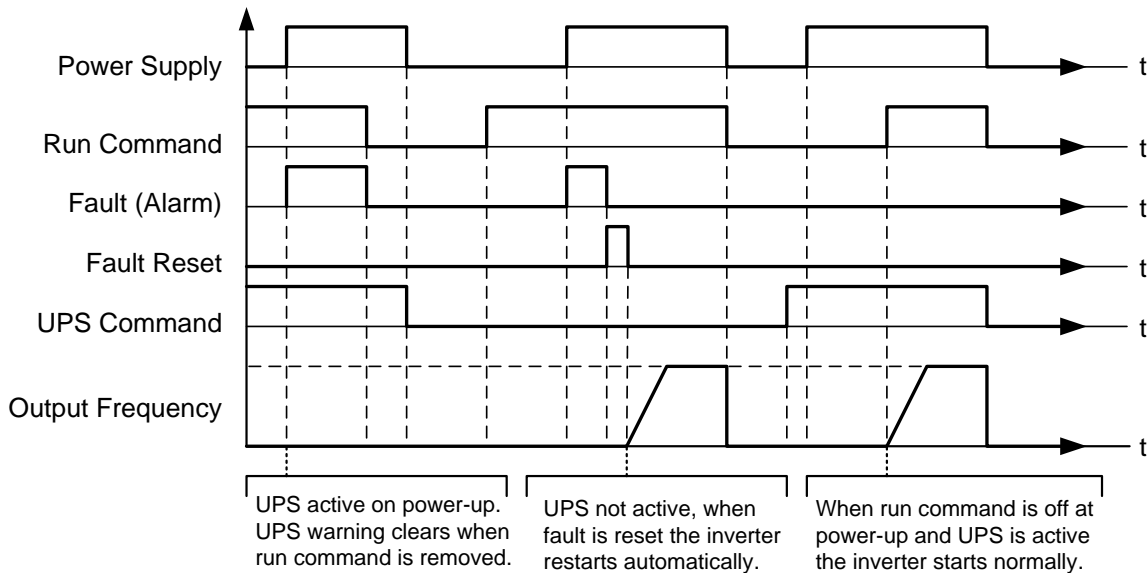

Figure 4.3.21a Unattended Start Protection

03-0X =53: 2-Wire Self Holding Mode (Stop Command).

Refer to the "2-wire operation with hold function" of parameter 00-02.

03-0X =54: Switch PID1 and PID2
Switch PID1 to PID2 when PID2 is active.

03-0X =55: RTC Time Enable

When input is active, enable RTC Timer.

Note: Parameter 16-13 (RTC timer function) has to be set to 2 (DI setting) for this input function to work.

03-0X =56: RTC Offset Enable

When input is active enables RTC Timer Offset set by parameter 16-31.

Note: Parameter 16-30 (RTC timer function) has to be set to 2 (DI setting) for this input function to work.

03-0X =57: Forced Frequency Run

When input is active and PID (10-03) is enabled forces the drive to run at a frequency reference set by parameter 23-28. This function is can be used for feedback loss detection.

03-0X =58: Run Permissive Function

When input is active, inverter will stop using the stop mode set in parameter 08-30.

| 03-08 | (S1~S6) DI Scan Time |
|-------|--|
| Range | 【0】 Scan Time 4ms 【1】 Scan Time 8ms |

Set the digital input CPU scan time. The digital input signal needs to be present for the minimum scan time to qualify as an enabled command.

Note: For noisy environments select scan time of 8ms (results in a slower response time).

| 03-09 | Multi-function Terminal S1-S4 Type Selection |
|-------|--|
| Range | 【xxx0b】 : S1 A contact 【xxx1b】 : S1 B contact 【xx0xb】 : S2 A contact 【xx1xb】 : S2 B contact 【x0xxb】 : S3 A contact 【x1xxb】 : S3 B contact 【0xxxb】 : S4 A contact 【1xxxb】 : S4 B contact |

| 03-10 | Multi-function Terminal S5-S6 Type Selection |
|-------|--|
| Range | 【xxx0b】 : S5 A contact 【xxx1b】 : S5 B contact 【xx0xb】 : S6 A contact 【xx1xb】 : S6 B contact |

Parameter 03-09 and 03-10 selects the digital input type between a normally open and a normally closed switch/contact.

Each bit of 03-09/03-10 presents an input:

03-09= 0 0 0 0 0: normally open switch
 s4 s3 s2 s1 1: normally closed switch

03-10= x x 0 0 0: normally open switch
 s6 s5 1: normally closed switch

Example: S1 and S2 wired to a normally closed contact / switch set 03-09=0011.



Do not set the operation command parameter 00-02 to terminal control before setting the digital input type. Failure to comply may cause death or serious injury.

| 03-11 | Relay (R1A-R1C) Output |
|-------|---|
| 03-12 | Relay (R2A-R2C) Output |
| 03-39 | Relay (R3A-R3C) Output |
| Range | <p>【0】 : During Running 【1】 : Fault Contact Output 【2】 : Frequency Agree 【3】 : Setting Frequency Agree (03-13±03-14) 【4】 : Frequency Detection 1 (> 03-13, Hysteresis interval is the setting value of 03-14) 【5】 : Frequency Detection 2 (< 03-13, Hysteresis interval is the setting value of 03-14) 【6】 : Automatic Restart 【7】 ~ 【8】 : Reserved 【9】 : Baseblock 【10】 ~ 【11】 : Reserved 【12】 : Over-Torque Detection 【13】 : Current Agree 【14】 ~ 【17】 : Reserved 【18】 : PLC Status 【19】 : PLC Control 【20】 : Zero Speed 【21】 : Inverter Ready 【22】 : Undervoltage Detection 【23】 : Source of Operation Command 【24】 : Source of Frequency Command 【25】 : Low Torque Detection 【26】 : Frequency Reference Missing 【27】 : Timing Function Output 【28】 ~ 【31】 : Reserved 【32】 : Communication Control Contacts 【33】 : RTC Timer 1 【34】 : RTC Timer 2 【35】 : RTC Timer 3 【36】 : RTC Timer 4 【37】 : Detection Output of PID Feedback Loss 【38】 : Brake Release</p> |

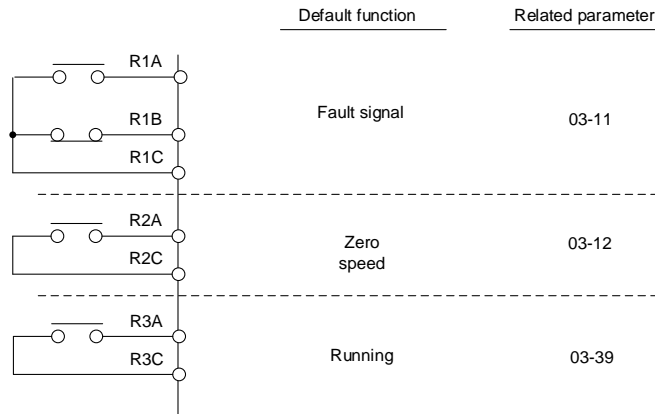

Figure 4.3.22 Multi-function digital output and related parameters

Table 4.3.6 Description of multi-function digital output

| Value | Function | | Description | Control Mode | | |
|-------|-------------------------|--------------------|--|--------------|-----|--------|
| | Name | LCD Display | | V/F | SLV | PM SLV |
| 0 | During Running | Running | ON: During running (Run Command is ON) | ○ | ○ | ○ |
| 1 | Fault Contact Output | Fault | ON: Fault contact output (except CF00 and CF01) | ○ | ○ | ○ |
| 2 | Frequency Agree | Freq. Agree | ON: Frequency agree (frequency agree width detection is set by 03-14) | ○ | ○ | ○ |
| 3 | Setting Frequency Agree | Setting Freq Agree | ON: Output frequency = allowed frequency detection level (03-13) ± frequency bandwidth (03-14) | ○ | ○ | ○ |
| 4 | Frequency Detection 1 | Freq. Detect 1 | ON: Output frequency > 03-13, Hysteresis interval is the setting value of 03-14 ON: Output frequency > 03-13, Hysteresis interval is the setting value of 03-14 | ○ | ○ | ○ |
| 5 | Frequency Detection 2 | Freq. Detect 2 | OFF: During acceleration: Output frequency ≥ 03-13 + 03-14 ON: During deceleration: Output frequency < 03-13 | ○ | ○ | ○ |
| 6 | Automatic Restart | Auto Restart | ON: the period of automatic restart | ○ | ○ | ○ |
| 7~8 | Reserved | Reserved | Reserved | - | - | - |
| 9 | Baseblock | Baseblock | ON: During baseblock | ○ | ○ | ○ |
| 10~11 | Reserved | Reserved | Reserved | - | - | - |
| 12 | Over-Torque Detection | Over Torque | ON: Over torque detection is ON | ○ | ○ | ○ |
| 13 | Current Agree | Current Agree | ON: Output current > 03-15 | ○ | ○ | ○ |
| 14~17 | Reserved | Reserved | Reserved | - | - | - |
| 18 | PLC Status | PLC statement | ON: when 00-02 is set to 3 (PLC operation command source) | ○ | ○ | ○ |
| 19 | PLC Control | Control From PLC | ON: Control from PLC | ○ | ○ | ○ |

| Value | Function | | Description | Control Mode | | |
|-------|---------------------------------------|-------------------|--|--------------|-----|--------|
| | Name | LCD Display | | V/F | SLV | PM SLV |
| 20 | Zero Speed | Zero Speed | ON: Output frequency < Minimum output frequency (Fmin) | ○ | ○ | ○ |
| 21 | Inverter Ready | Ready | ON: Inverter ready (after power on, no faults) | ○ | ○ | ○ |
| 22 | Undervoltage Detection | Low Volt Detected | ON: DC bus voltage = < Low-voltage warning detection level (07-13) | ○ | ○ | ○ |
| 23 | Source of Operation Command | Run Cmd Status | ON: Operation command from LED digital operator (local mode) | ○ | ○ | ○ |
| 24 | Source of Frequency Command | Freq Ref Status | ON: Reference frequency from LED digital operator (local mode) | ○ | ○ | ○ |
| 25 | Low Torque Detection | Under Torque | ON: Low-torque detection is ON | ○ | ○ | ○ |
| 26 | Frequency Reference Missing | Ref. Loss. | ON: Reference frequency loss | ○ | ○ | ○ |
| 27 | Timing Function Output | Timer Output | Set time function parameter to 03-33 and 03-34, and the time function input is set by parameter from 03-00 and 03-05 | ○ | ○ | ○ |
| 28~31 | Reserved | Reserved | Reserved | - | - | - |
| 32 | Communication Control Contacts | Control From Comm | ON: DO is set by communication control. | ○ | ○ | ○ |
| 33 | RTC Timer 1 | RTC Timer 1 | ON: 16-36 (RTC Speed Selection) selects Timer 1 and 16-32 (Source of Timer 1) is active in the set time. | ○ | ○ | ○ |
| 34 | RTC Timer 2 | RTC Timer 2 | ON: 16-36 (RTC Speed Selection) selects Timer 2 and 16-33 (Source of Timer 2) is active in the set time. | ○ | ○ | ○ |
| 35 | RTC Timer 3 | RTC Timer 3 | ON: 16-36 (RTC Speed Selection) selects Timer 3 and 16-34 (Source of Timer 3) is active in the set time. | ○ | ○ | ○ |
| 36 | RTC Timer 4 | RTC Timer 4 | ON: 16-36 (RTC Speed Selection) selects Timer 4 and 16-35 (Source of Timer 4) is active in the set time. | ○ | ○ | ○ |
| 37 | Detection Output of PID Feedback Loss | PID Fbk Loss | ON: PID Feedback Loss | ○ | ○ | ○ |
| 38 | Brake Release | Brake Release | ON: Brake Release | X | ○ | X |

03-1X=0: During Running

| | |
|-----|--|
| OFF | Run command is OFF and the inverter is stopped. |
| ON | Run command is ON or output frequency is greater than 0. |

03-1X=1: Fault contact output

Output is active during fault condition.

Note: Communication error (CF00, CF01) do not activate the fault contact.

03-1X=2: Frequency Agree

Output is active when the output frequency falls within the frequency reference minus the frequency detection width (03-14).

03-1X=3: Setting Frequency Agree

Output is active when the output frequency falls within the frequency detection width (03-14) of the set frequency detection level (03-13).

03-1X=4: Frequency detected 1

Output is active when the output frequency rises above the frequency detection level (03-13) + frequency detection width (03-14) and deactivates when the output frequency falls below frequency detection level (03-13).

03-1X=5: Frequency detected 2

Output is active when the output frequency is below the frequency detection level (03-13) + frequency detection width (03-14) and turns off when the output frequency falls below frequency detection level.

03-1X=6: Automatic restart.

Output is active during an auto-restart operation.

03-1X=9: Baseblock (B.B.)

Output is active when the inverter output is turned off during a Baseblock command.

03-1X=12: Over torque detected (Normally Open)

Output is active during an over torque detection see parameters 08-13 ~ 08-16.

03-1X=25: Low torque detected (Normally Open)

Output is active during low torque detection see parameters 08-17 ~ 08-20.

03-1X=13: Current Agree

When the output current is larger than that in 03-15 and its duration is higher than that in 03-16, this function will be ON.

03-1X=18: PLC status (setting =18)

Output is c when operation command parameter (00-02) is set to 3: PLC Control.

03-1X=19: PLC control contact

Output is controlled by the PLC logic

03-1X=20: Zero-speed

Output is active during zero-speed

| | |
|--------|--|
| Active | Output frequency \geq minimum output frequency (01-08, Fmin) |
| Off | Output frequency is \leq the minimum output frequency |

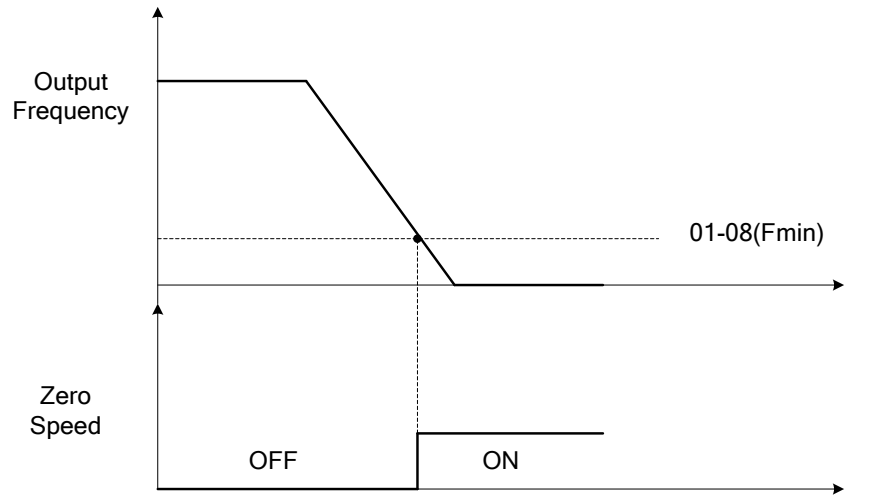

Figure 4.3.23 Zero-speed operation

03-1X=21: Inverter Ready

Output is active when no faults are active and the inverter is ready for operation.

03-1X=22: Undervoltage Detection

Output is active when the DC bus voltage falls below the low voltage detection level (07-13).

03-1X=23: Source of operation command

Output is active in local operation command.

| | |
|------------|--|
| OFF | Remote mode: 00-02 = 1 or 2, or any one of the multi-function digital input terminals (S1 to S6) set to function 5 (LOCAL / REMOTE control) is OFF. SEQ LED of the keypad is ON. |
| ON | Local mode: 00-02 = 0, or any one of the multi-function digital input terminals (S1 to S6) set to function 5 (LOCAL / REMOTE control) is active. SEQ LED of the keypad is OFF. |

03-1X=24: Source of frequency command

Output is active in local frequency command.

| | |
|------------|--|
| OFF | Remote mode: 00-05 = 1 or 2, or any one of the multi-function digital input terminals (S1 to S6) set to function 5 (LOCAL / REMOTE control) is OFF. REF LED of the keypad is ON. |
| ON | Local mode: 00-05 = 0, or any one of the multi-function digital input terminals (S1 to S6) set to function 5 (LOCAL / REMOTE control) is active. REF LED of the keypad is OFF. |

03-1X=26: Frequency reference missing

Output is active when the frequency reference is lost. When parameter 11-41 is set to 0 the inverter will decelerate to a stop. When parameter 11-41 is set to 1 operation will continue at the value of parameter 11-42 times the last know frequency reference.

03-1X=27: Time function output

Output is controlled by timer function see parameter 03-37 and 03-38.

03-1X=32: Communication control contacts

Output is active when communication control is active.

03-1X=37: Detection Output of PID Feedback Loss

When PID feedback loss occurs (refer to parameters setting 10-11~10-13), this function will be ON.

03-1X=38: Brake Release

When this function is ON, Break release is enabled. Refer to parameters descriptions of 03-41~03-42.

| | |
|--------------|--|
| 03-13 | Frequency Detection Level |
| Range | 【0.0~400.0】 Hz 【0.0~1200.0】 Hz (when 00-31 = 1) |
| 03-14 | Frequency Detection Width |
| Range | 【0.1~25.5】 Hz |

Frequency Detection Level: set the multi-function output terminals R1A-R1C, R2A-R2C or R3A-R3C to the desired detection level and bandwidth for use with multi-function output functions 2 to 5.

The time charts for the Frequency Agree Detection operation are shown in the following Table 4.3.7.

Table 4.3.7 Frequency Detection Operation

| Function | Detection operation of frequency confirmation | Description |
|--|---|--|
| <p>Frequency agree</p> | | <ul style="list-style-type: none"> • If output frequency is higher than the value of Frequency Detection Level (03-13) + Frequency Detection Width (03-14), the signal of output frequency detection 1 is ON. • If output frequency is lower than Frequency Detection Level (03-13), the signal of output frequency detection 1 is OFF. • If output frequency value falls between (03-13) and (03-13) + (03-14), the signal of output frequency detection 1 is the same as the previous value. • Any of the digital outputs function (03-11, 03-12 or 03-39) can be set to 4 (Output Frequency Detection 1). |
| <p>Set frequency agree</p> | | <ul style="list-style-type: none"> • If output frequency is higher than the value of Frequency Detection Level (03-13) + Frequency Detection Width (03-14), the signal of output frequency detection 1 is OFF. • If output frequency is lower than Frequency Detection Level (03-13), the signal of output frequency detection 1 is ON. • If output frequency value falls between (03-13) and (03-13) + (03-14), the signal of output frequency detection 2 is the same as the previous value. • Any of the digital outputs function (03-11, 03-12 or 03-39) can be set to 5 (Output Frequency Detection 2). |
| <p>Output frequency detection 1</p> | | <ul style="list-style-type: none"> • Output is active when the output frequency rises above the frequency detection level (03-13) + frequency detection width (03-14) and deactivates when the output frequency falls below frequency detection level (03-13). • Any of the digital outputs function (03-11, 03-12 or 03-39) can be set to 4 (Output frequency detection 1). |
| <p>Output frequency detection 2</p> | | <ul style="list-style-type: none"> • Output is active when the output frequency is below the frequency detection level (03-13) + frequency detection width (03-14) and turns off when the output frequency falls below frequency detection level. • Any of the digital outputs function (03-11, 03-12 or 03-39) can be set to 5 (Output frequency detection 2). |

| | |
|--------------|--|
| 03-15 | Current Agree Level |
| Range | 【0.1~999.9】 A |
| 03-16 | Delay Time of Current Agree Detection |
| Range | 【0.1~10.0】 Sec |

- **03-11=13** : Relay is active when output current is larger than that in 03-15.
- **03-15** : The setting value (**0.1~15.0**) depends on motor rated current.
- **03-16** : The unit of the setting value (**0.1~10.0**) is second. The delay time of relay signal from ON to OFF is 100ms (constant).

Timing Diagram:

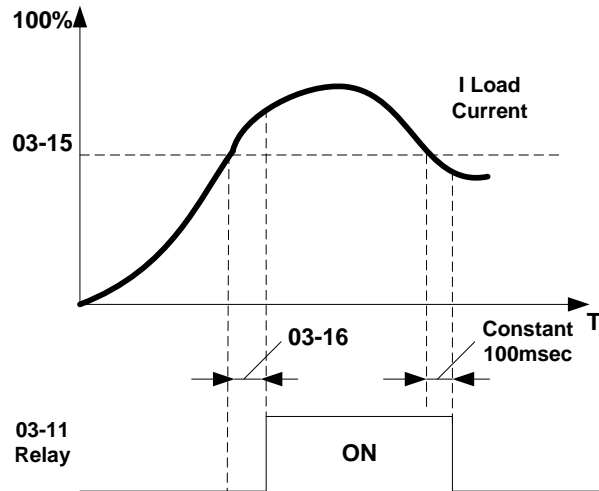

| | | |
|--------------|-------------------------------|-------------------------------|
| 03-19 | Relay (R1A-R3C) Type | |
| Range | 【xx0b】 : R1 A contact | 【xx1b】 : R1 B contact |
| | 【xx0xb】 : R2 A contact | 【xx1xb】 : R2 B contact |
| | 【x0xxb】 : R3 A contact | 【xx1xb】 : R3 B contact |

Parameter 03-19 selects the digital output type between a normally open and a normally closed contact.
Each bit of 03-19 presents an output:

03-19= 0 0 0 0 **0**: normally open contact
 R3 R2 R1 **1**: normally close contact

Example: R1 normally closed and R2 normally open contact set 03-19=xx001.

| | |
|--------------|---|
| 03-27 | UP/DOWN Frequency Hold/ Adjust Selection |
| Range | 【0】 : Keep UP/DOWN frequency when stopping. 【1】 : Clear UP/DOWN frequency when stopping. 【2】 : Allow frequency UP/DOWN when stopping. 【3】 : Refresh frequency at acceleration. |

03-27=0: When the run command is removed the UP/DOWN frequency reference before deceleration is stored. The next time the run command is applied the output frequency will ramp up to the previously stored frequency reference.

03-27=1: When the run command is removed the UP/DOWN frequency reference command is cleared (set to 0). The next time the run command is applied the output frequency will start at 0.

03-27=2: UP/DOWN command is active when run command is not active.

03-27=3: Keep the state of frequency command not to be cleared. When Run Command re-sends, press UP/DOWN key before the run frequency reaches the frequency command, press UP/ DOWN key, then:

- When 03-40 = 0, Frequency Command is set by Run Frequency.
- When 03-40 ≠ 0, Frequency Command is set by the values of Run Frequency plus the setting frequency of 03-40.

| 03-30 | Pulse Input Selection |
|-------|--|
| Range | 【0】 : Common Pulse Input 【1】 : PWM (Pulse Width Modulation) |

There are two modes in pulse input selection:

03-30=0: Common Pulse Input

Pulse Input (PI) = the selected frequency divided by pulse input scaling (set by 03-31), corresponding to the maximum output frequency of motor 1 (01-02).

Note: Monitor parameter 12-79 (pulse input percentage) displays the proportional relationship between input signal and 03-31 (pulse input scaling).

03-30=1: PWM (Pulse Width Modulation)

It is required to input the correct frequency.

PWM= positive edge pulse time divided by previous pulse time period, corresponding to the maximum output frequency of the motor 1 (01-02).

Note: Monitor parameter 12-79 (pulse input percentage) displays the proportional relationship between the positive edge of input signal and time period.

Note: Tolerance range of pulse time period in PWM modes is ±12.5%. If it is over than the range, it is inactive.

Pulse input selection diagram:

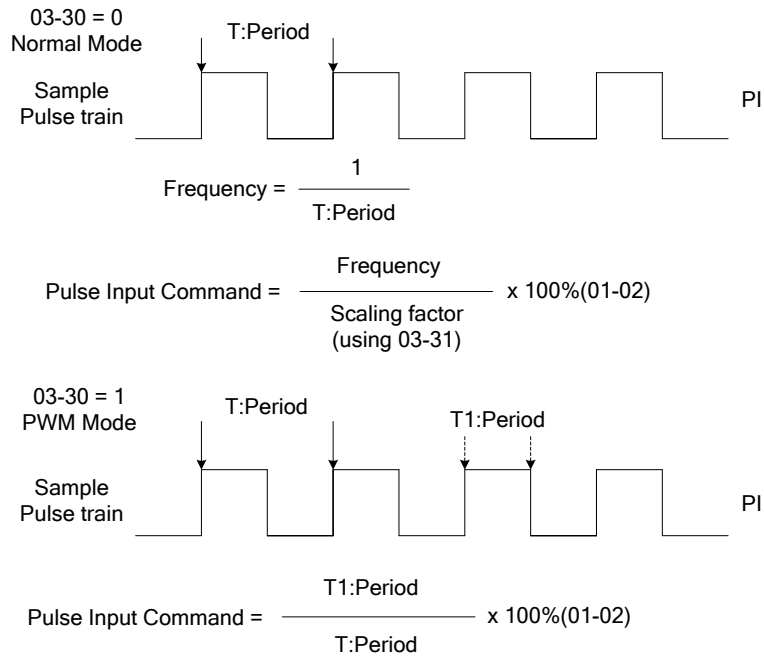

| | |
|--------------|----------------------------|
| 03-31 | Pulse Input Scaling |
| Range | 【50~32000】 Hz |

Pulse input scaling, 100% = Maximum pulse frequency.

| | |
|--------------|-------------------------|
| 03-32 | Pulse Input Gain |
| Range | 【0.0~1000.0】 % |

Target value (03-03) in % = Pulse input frequency scaled to 100% based on maximum pulse frequency (03-31) times the gain (03-32) + bias (03-33).

| | |
|--------------|-------------------------|
| 03-33 | Pulse Input Bias |
| Range | 【-100.0~100.0】 % |

Target value (03-03) in % = Pulse input frequency scaled to 100% based on maximum pulse frequency (03-31) times the gain (03-32) + bias (03-33).

| | |
|--------------|--------------------------------|
| 03-34 | Pulse Input Filter Time |
| Range | 【0.00~2.00】 Sec |

* Refer to Fig.4.3.24 for the pulse input specification.

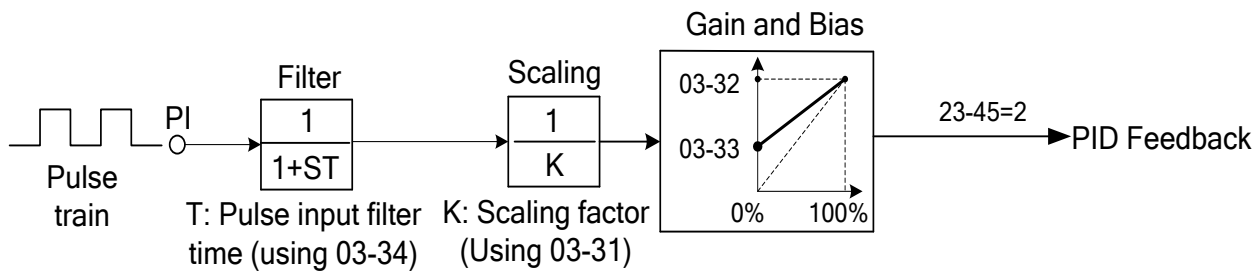

Figure 4.3.24 Pulse input adjustment

Set Pulse Input Setup as Flow Meter Input

Set parameter 23-45 (Flow Meter Feedback) to 2 (Pulse Input) to use the pulse input terminal PI for a flow meter pulse input. Refer to the description of parameter group 23 for details. Next set the pulse input scaling (03-31), enter the pulse input frequency to match the maximum output frequency. Adjust the pulse input filter time (03-34) to compensate for interference or noise.

| | |
|--------------|--------------------------------|
| 03-37 | Timer ON Delay (DI/DO) |
| Range | 【0.0~6000.0】 Sec |
| 03-38 | Timer OFF Delay (DI/DO) |
| Range | 【0.0~6000.0】 Sec |

Enable the timer function by setting one of multi-function input parameters 03-00~03-05 (S1 to S6) to 35 (timer function input) and one of multi-function output parameters 03-11, 03-12, 03-39 (R1A-R1C to R3A- R3C) to 27 (timer function output).

The timer function can be used to implement a timer relay. Use timing parameter 03-37 and 03-38 to set the timer ON / OFF delay.

Timer output is turned ON when the multi-function timer input is ON for the time specified in parameter 03-37.

Timer output is turned OFF after the multi-function timer input is OFF for the time specified in parameter 03-38.

Timing example:

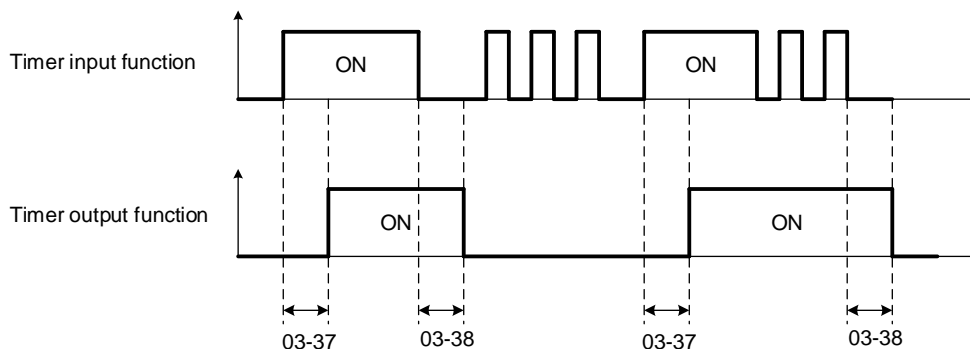

| | |
|--------------|--|
| 03-40 | Up/down Frequency Width Setting |
| Range | 【0.00~5.00】 Hz |

For example: Set terminal **S1: 03-00=【8】 (Up Frequency Increasing Command)**, **S2: 03-01=【9】 (DOWN Frequency Decreasing Command)** and **03-40=【△】 Hz**.

Mode1: When 03-40 is set to 0Hz, the standard up/down function is active, as shown in Fig. 4.3.17.

Mode2: When 03-40 is set to a value greater than 0Hz and terminal is active less than 2 sec. will result in a frequency change of ΔHz (setting frequency 03-40).

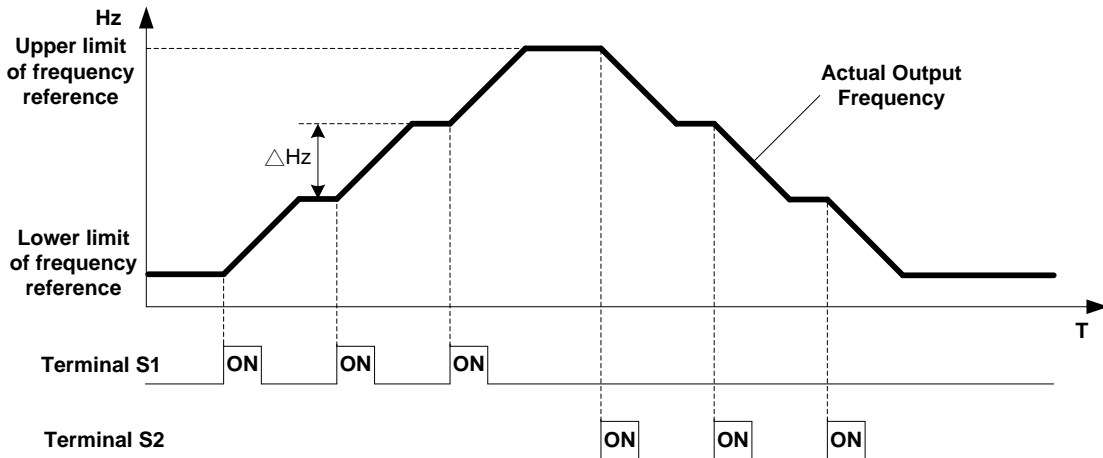

Mode3: When 03-40 greater than 0Hz and input terminal is active for more than 2 sec, frequency will ramp using the acceleration/ deceleration times.

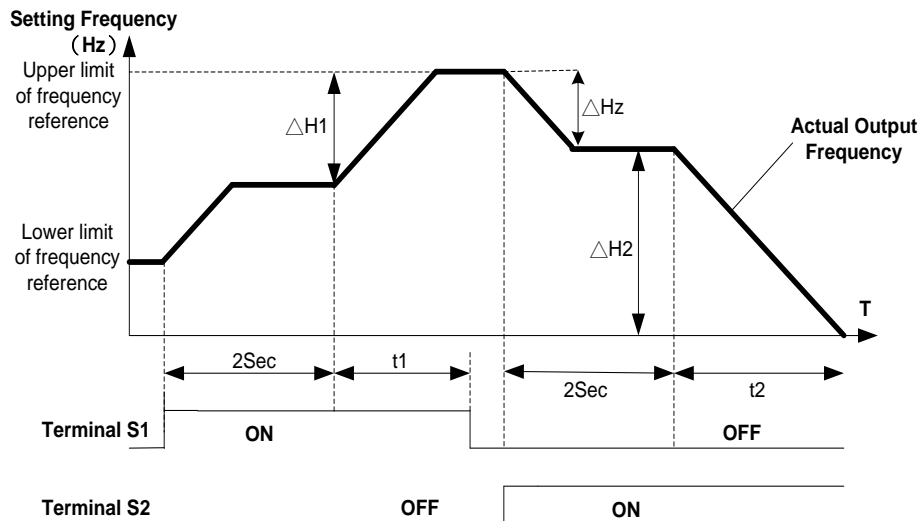

Notes:

$\Delta H1$: Increase frequency reference and accelerate to new frequency, t_1 : terminal active during acceleration.

$\Delta H2$: Decrease frequency reference and decelerate to new frequency, t_2 : terminal active during deceleration.

$$\Delta H1 = \frac{\text{Upper Limit Frequency}}{\text{Acceleration Time2}} \times \text{Terminal Conduction Time}(t_1)$$

$$\Delta H2 = \frac{\text{Lower Limit Frequency}}{\text{Deceleration Time2}} \times \text{Terminal Conduction Time}(t_2)$$

| | |
|--------------|-------------------------------------|
| 03-41 | Torque Detection Level |
| Range | 【0~300】 % |
| 03-42 | Delay Time of Braking Action |
| Range | 【0.00~65.00】 Sec |

Brake Release Function:

The brake release function requires uses frequency agree as shown in the following figure.

When output frequency is greater than frequency detection level (03-13) and output torque is greater than torque detection level (03-41) for the time specified in 03-42 (delay braking action delay time) the brake will release.

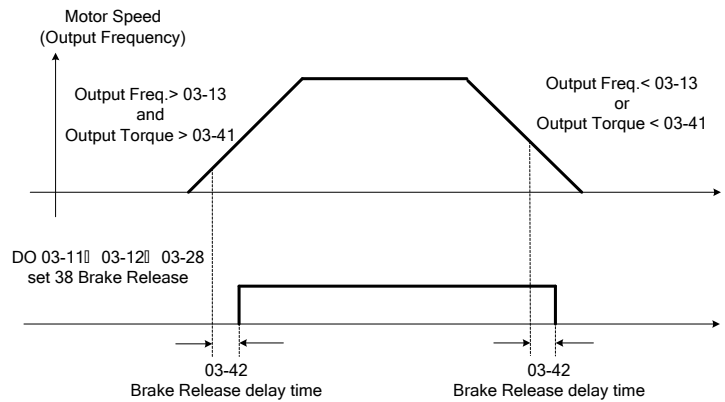

It is recommended to use the start and stop frequency lock function (11-43~11-46), as shown in the following figure:

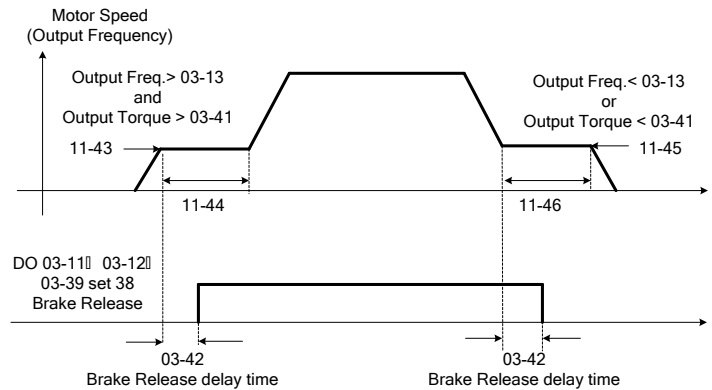

| | |
|--------------|--|
| 03-43 | UP/DOWN Acceleration/ Deceleration Selection |
| Range | 【0】 : Acceleration/Deceleration Time 1 【1】 : Acceleration/Deceleration Time 2 |

Select acceleration/ deceleration time for the UP/DOWN function. Example: $\Delta H1$ (set frequency increment at acceleration) and $\Delta H2$ (set frequency increment at deceleration).

Group 04 External Analog Input and Output Parameters

| | |
|--------------|---|
| 04-00 | AI Input Source Selection |
| Range | 【0】 : AI2 0~10V 【1】 : AI2 4~20mA |
| 04-01 | AI1 Signal Filter Time |
| Range | 【0.00~2.00】 Sec |
| 04-02 | AI1 Gain |
| Range | 【0.0~1000.0】 % |
| 04-03 | AI1 Bias |
| Range | 【-100~100.0】 % |
| 04-05 | AI2 Function Setting |
| Range | 【0】 : Auxiliary Frequency 【1】 : Frequency Reference Gain 【2】 : Frequency Reference Bias 【3】 : Output Voltage Bias 【4】 : Acceleration and Deceleration Scaling 【5】 : DC Braking Current* 【6】 : Over-Torque Level 【7】 : Stall Prevention Level During Running 【8】 : Frequency Reference Lower Limit 【9】 : Jump Frequency 4 【10】 : Added to AI1 【11】 : Positive Torque Limit 【12】 : Negative Torque Limit 【13】 : Regenerative Torque Limit 【14】 : Positive / Negative Torque Limit 【15】 : Reserved 【16】 : Torque Compensation |
| 04-06 | AI2 Signal Filter Time |
| Range | 【0.00~2.00】 Sec |
| 04-07 | AI2 Gain |
| Range | 【0.0~1000.0】 % |
| 04-08 | AI2 Bias |
| Range | 【-100.0~100.0】 % |

Refer to the followings for the details of parameter 04-00 (AI input signal type)

- ① AI2=0~10V, Set 04-00=0, set SW2 on the control board to V.
- ② AI2=0~20mA, Set 04-00=0, set SW2 on the control board to I.
- ③ AI2=4~20mA, Set 04-00=1, set SW2 on the control board to I.
- ④ AI2=2~10V, Set 04-00=1 or 3, set SW2 on the control board to V.

(1) Analog Input Level Adjustment AI1, AI2 (04-02, 04-03, 04-07, 04-08)

Each analog input AI1 and AI2 has a separate gain and bias parameter associated with it.

Analog input signal AI1 can be adjusted with parameter 04-02 and 04-03; Analog input signal AI2 can be adjusted with parameter 04-07 and 04-08. Refer to Fig.4.3.25.

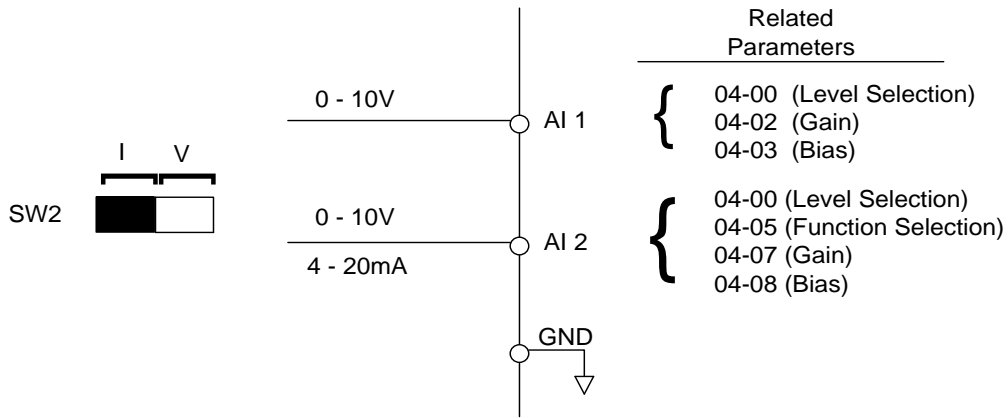

Figure 4.3.25 Analog inputs and related parameters

Gain setting: Sets the level in % that corresponds to a 10V or 20mA signal at the analog input.

Bias setting: Sets the level in % that corresponds to a 0V or 4mA signal at the analog input.

Use both gain and bias setting to scale the input signal.

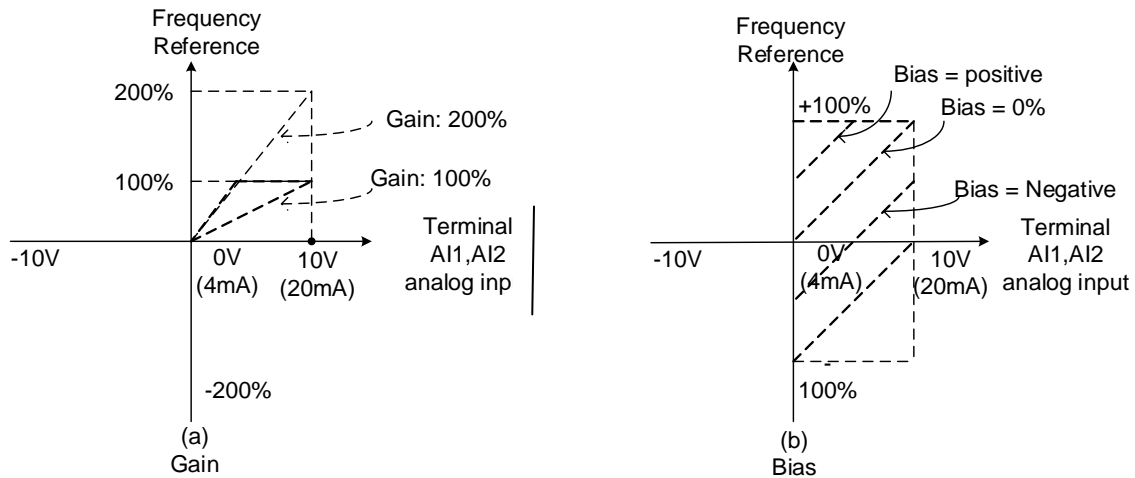

Figure 4.3.26 Gain and bias operations (for frequency reference signal)

(2) AI1 signal filtering time (04-01)

(3) AI2 signal filtering time (04-06)

All analog inputs (AI1, AI2) have a 1st order programmable input filter that can be adjusted when noise is present on each of the incoming analog signal to prevent erratic drive control.

The filter time constant (range: 0.00 to 2.00 seconds) is defined as the time that the input step signal reaches 63% of its final value.

Note: Increasing the filter time causes the drive operation to become more stable but less responsive to change to the analog input.

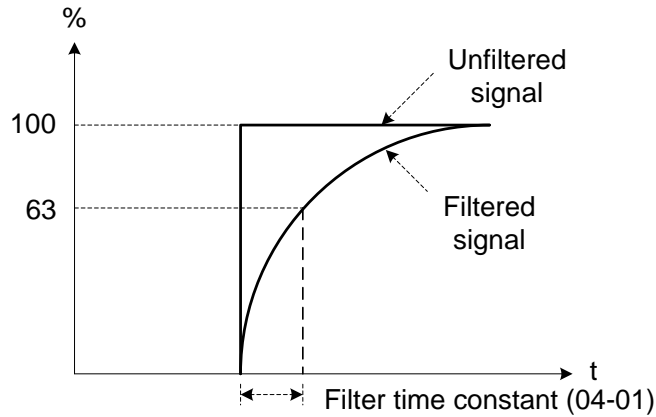

Figure 4.3.27 Filter time constant

(4) AI2 function setting (04-05)

AI2 is multi-function analog input terminal function selection. Refer to Table 4.3.8 for function overview

Table 4.3.8 Multi-function analog input list (04-05 setting)

| Value | Function | | Description | Control mode | | |
|-------|--|-------------------|--|--------------|-----|--------|
| | Name | LCD Display | | V/F | SLV | PM SLV |
| 0 | Auxiliary Frequency | AUX.Freq Ref | Max Output Frequency (01-02, Fmax) =100% | ○ | ○ | ○ |
| 1 | Frequency Reference Gain (FGAIN) | Freq Ref Gain | Aggregated gain = AI1 = 04-02 * FGAIN | ○ | ○ | ○ |
| 2 | Frequency Reference Bias (FBIAS) | Freq Ref Bias | Aggregated bias = AI1 = 04-03 * FBIAS | ○ | ○ | ○ |
| 3 | Output Voltage Bias (VBIAS) | Output Volt Bias | Aggregate output voltage = V/F curve voltage + VBIAS | ○ | X | ○ |
| 4 | Coefficient of Acceleration and Deceleration Reduction (K) | Tacc/Tdec Scaling | Actual acceleration and deceleration time = accel. and decal. time / K | ○ | ○ | ○ |
| 5 | DC Braking Current* | DC Inj Current | Adjust the DC braking current (0 ~ 100%) based on analog input. When the inverter rated current = 100%, DC braking current 07-07 is disabled. | ○ | ○ | ○ |
| 6 | Over-Torque Detection Level | Over Tq Level | Change over-torque detection level based on over-torque detection level, at this time, 08-15 is disabled. | ○ | ○ | ○ |
| 7 | Stall Prevention Level During Running | Run Stall Level | Adjust the action level (30% ~ 200%) of stall prevention in operation based on analog input. The inverter rated current =100% | ○ | X | ○ |
| 8 | Frequency Lower Limit | Ref. Low Bound | Adjust the lower limit (0 ~ 100%) of frequency command based on analog input, the maximum output = 100%. The lower limit of frequency command is the greater one of the actual frequency command's lower limit 00-13 or the multi-function analog input. | ○ | ○ | ○ |
| 9 | Jump Frequency 4 | Jump Freq 4 | Jump frequency 4. 100% = maximum output frequency | ○ | ○ | ○ |

| Value | Function | | Description | Control mode | | |
|-------|----------------------------------|-------------------|--|--------------|-----|--------|
| | Name | LCD Display | | V/F | SLV | PM SLV |
| 10 | Added to AI1 | Add to AI1 | Added to AI1. 100% = maximum output frequency | ○ | ○ | ○ |
| 11 | Positive Torque Limit | Positive Tq Limit | 100% = Motor's rated torque | X | ○ | ○ |
| 12 | Negative Torque Limit | Negative Tq Limit | 100% = Motor's rated torque | X | ○ | ○ |
| 13 | Regenerative Torque Limit | Regen. Tq Limit | 100% = Motor's rated torque | X | ○ | ○ |
| 14 | Positive / Negative Torque Limit | +/- Tq Limit | 100% = Motor's rated torque | X | ○ | ○ |
| 15 | Torque Limit | Tq Limit | 100% = Motor's rated torque | X | X | X |
| 16 | Torque Compensation | Tq Compensation | 100% = Motor's rated torque | X | ○ | X |
| 17 | Reserved | No Function | Reserved | ○ | ○ | ○ |

04-05=0: Auxiliary frequency

When parameter 00-05 = 1 (main frequency from external control) the auxiliary speed reference frequency can be activated via the multi-speed input commands (see table 4.3.5). The auxiliary frequency command can be set via AI2. The maximum output frequency is set by 01-02, $F_{max} = 100\%$.

04-05=1: Frequency Reference Gain (FGAIN)

Multi-function analog input AI2 can be used to adjust the frequency reference gain of analog input AI1. The total frequency reference gain of terminal AI1 is the internal gain set by parameter 04-02 times FGAIN. The maximum frequency reference for AI1 is 100%.

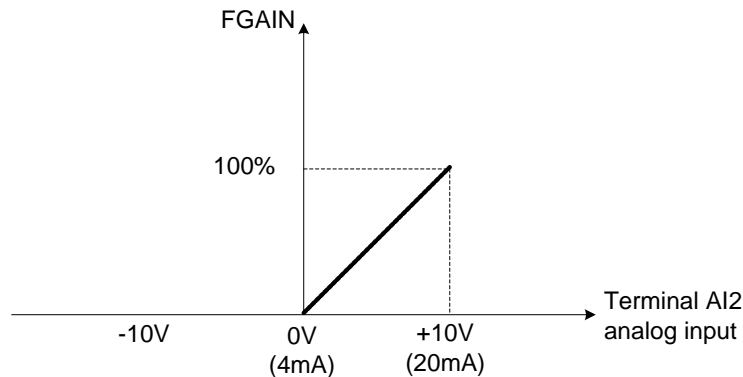

Figure 4.3.28 Frequency gain adjustment

Example:

When the internal gain of AI1 (04-02) is set to 100% and AI2 to 5V (for example FGAIN = 50%), the reference frequency of terminal AI1 will be 50%, as shown in Fig. 4.3.29.

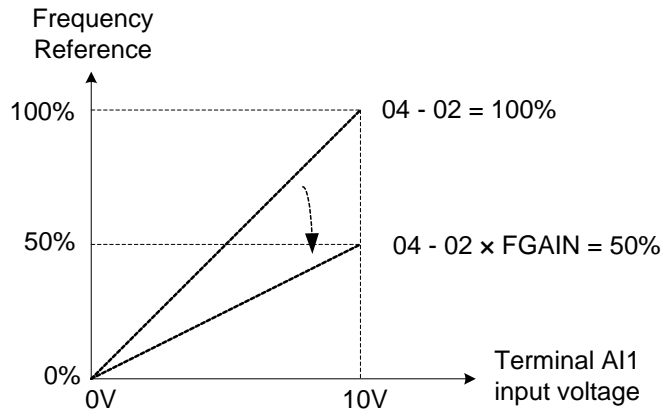

Figure 4.3.29 Frequency reference gain adjustment (example)

04-05=2: Frequency Reference bias (FBIAS)

Multi-function analog input terminal AI2 can be used to adjust the frequency reference bias of AI1. The total frequency reference bias of terminal AI1 is the sum of internal bias set by parameter 04-03 and FBIAS. The maximum frequency reference for AI1 is 100%.

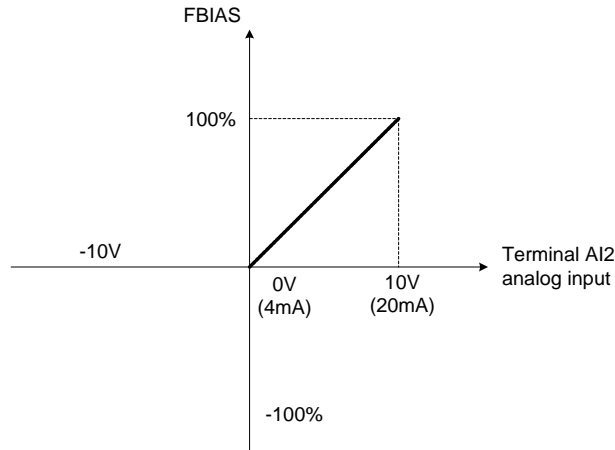

Figure 4.3.30 Bias adjustment

Example:

Terminal AI1 input is 0V, 04-02 = 100% (AI1 gain), 04-03 = 0% (AI1 bias) and terminal AI2 input is 3V. The reference frequency will be 30% as shown in Fig.4.3.31.

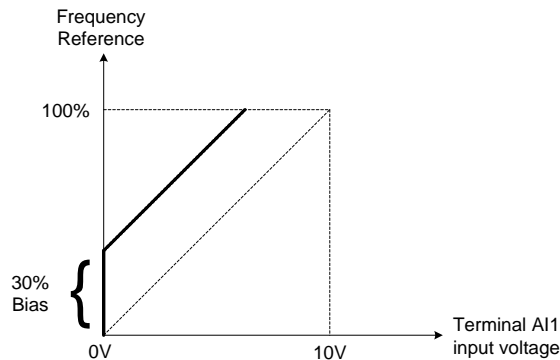

Figure 4.3.31 Frequency Reference bias adjustment (example)

04-05=3: Output Voltage Bias (VBIAS)

Multi-function analog input AI2 can be used to adjust the output voltage. The total output voltage of inverter is the sum of output voltage based on the selected V/F curve and VBIAS.

The maximum output voltage is set by 01-03, $V_{max} = 100\%$.

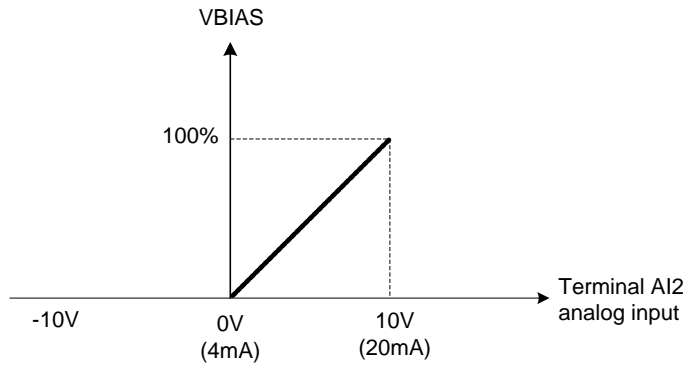

Figure 4.3.32 Bias adjustment

04-05=4: Acceleration and deceleration coefficient (K)

Multi-function analog input AI2 can be used to adjust the acceleration and deceleration time coefficient. The actual acceleration and deceleration time is calculated as follows:

$$\text{Actual accel / decel time} = \frac{\text{Acceleration / Deceleration time (00-14 ~ 00-17, 00-21~ 00-24)}}{K}$$

Acceleration/ Deceleration time setting is 100% (00-14~00-17, 00-21~00-24).

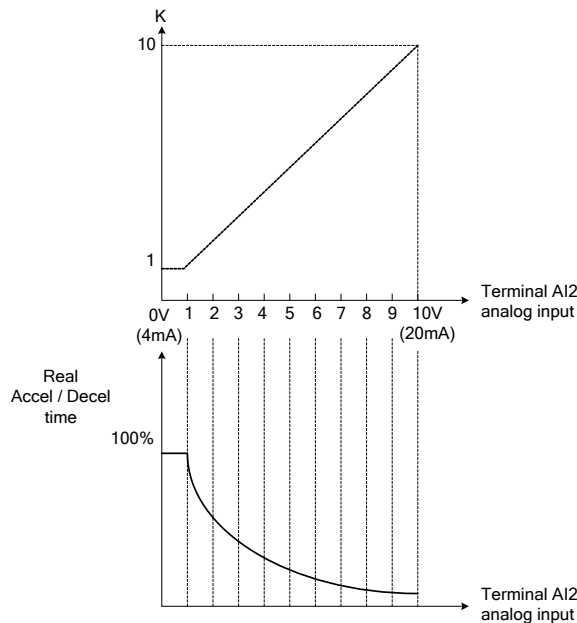

Figure 4.3.33 Acceleration / deceleration time reduction coefficient

04-05=5: DC braking current

Multi-function analog input AI2 can be used to adjust the DC Injection braking current.

DC braking current parameter 07-07 setting should be set to 0% to use this function.

The inverter rated current = 100%

Note: When using the permanent magnet (PM) motor, there will be no options of setting 5.

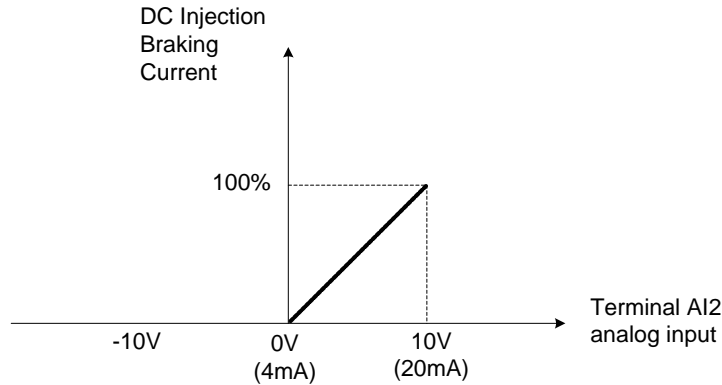

Figure 4.3.34 DC braking current adjustment

04-05=6: Over-torque detection level

Multi-function analog input AI2 can be used to adjust the over-torque detection level.

100% of inverter rated current (V/F control mode)

100% motor rated torque (SLV control mode)

If the multi-function analog input is used to adjust the over-torque level, the internal over-torque detection level (08-15) is disabled.

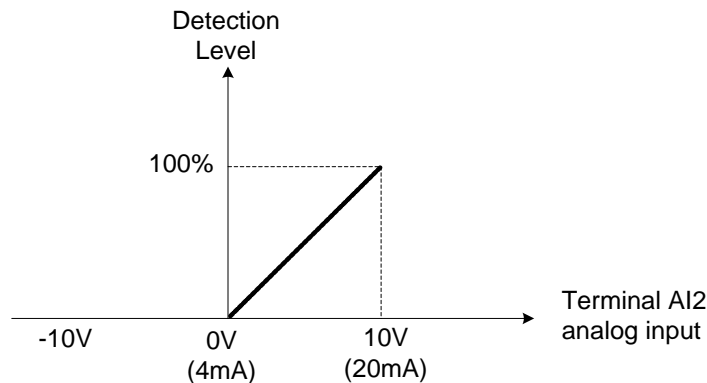

Figure 4.3.35 Over-torque/less torque detection level adjustment

4-05=7: Stall prevention level during running

Multi-function analog input AI2 can be used to adjust the stall prevention level during operation.

Inverter rated current = 100%. When AI2 is set to control stall prevention level (04-05 = 7) and parameter 08-03 (Stall prevention level during operation) is used, then the lesser of the two value becomes the active stall prevention level during operation.

Example: If the motor power is less than that of the inverter, the operation and the stall prevention of the motor will be based on the factory settings, multi-function analog input AI2 can be used to reduce the stall prevention level during operation.

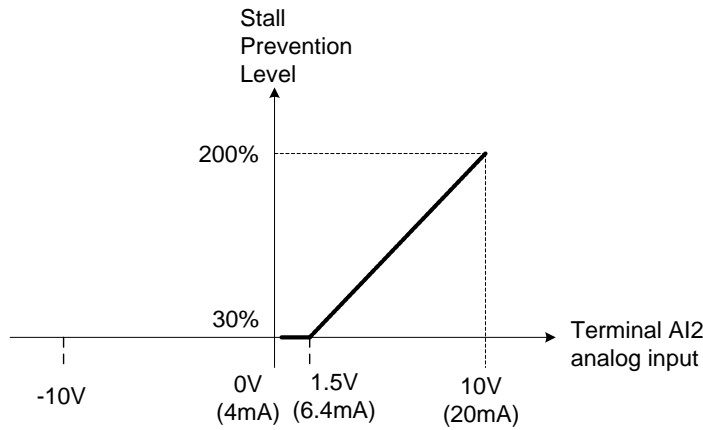

Figure 4.3.36 Stall prevention level adjustment during operation

04-05=8: Frequency lower limit

Multi-function analog input AI2 can be used to adjust the lower limit of frequency reference. Maximum output frequency (Fmax, 01-02) = 100%. The actual lower limit is determined by the maximum value of 00-13 (frequency lower limit) and level of the multi-function analog input AI2.

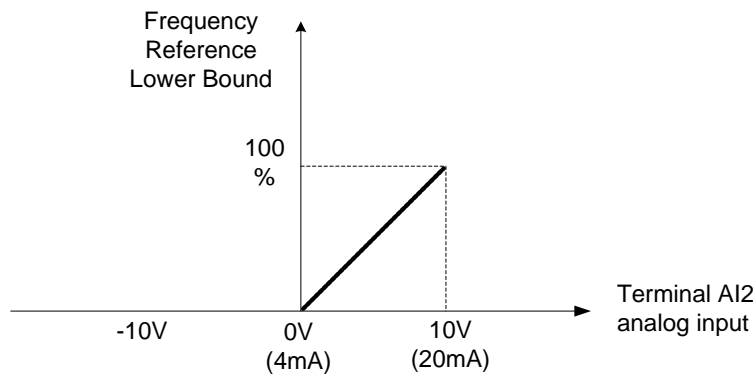

Figure 4.3.37 Adjustment of lower limit of frequency reference

04-05=9: Jump frequency 4

Multi-function analog input AI2 can be used to adjust Jump frequency 4.

Maximum output frequency (01-02, Fmax) = 100%. Setting 11-08 ~ 11-10 to 0.0Hz turns of the Jump frequency function.

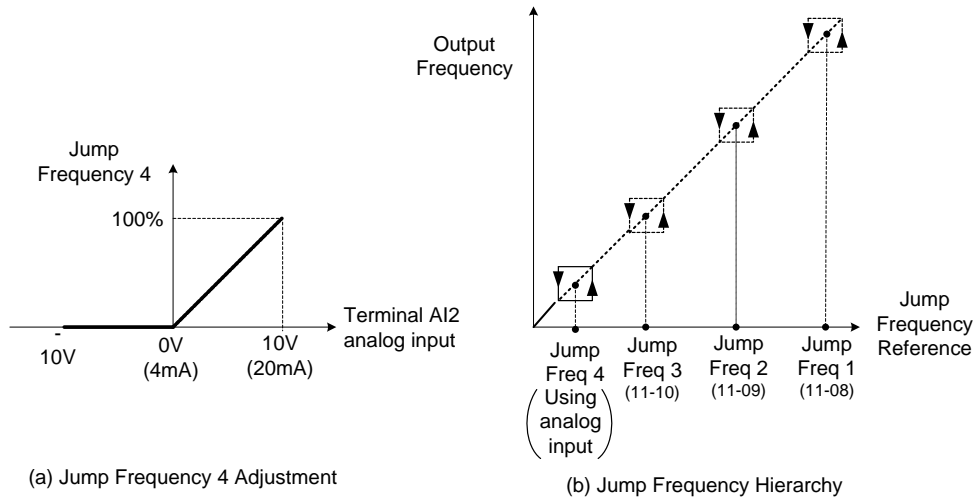

Figure 4.3.38 Jump frequency 4 setting operation

04-05=10: Added to AI1

Multi-function analog input AI2 can be used as a bias level for analog input AI1.

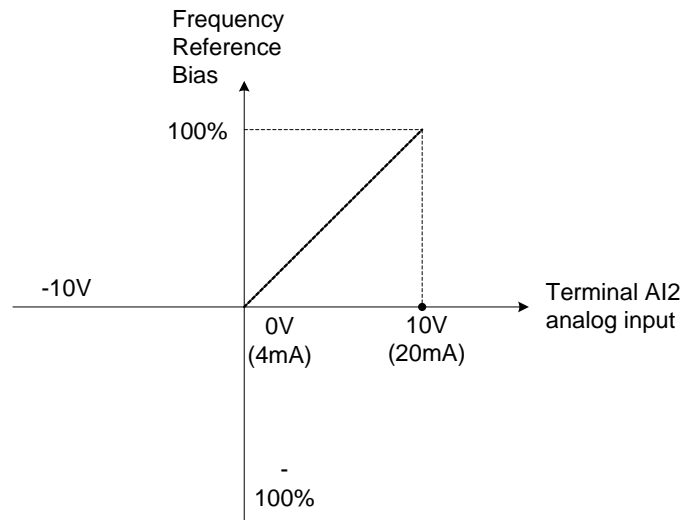

Figure 4.3.39 Added to AI1 as a bias operation

Example:

04-02 (AI1 gain) = 100%, 04-03 (AI2 gain) = 0%, and terminal AI2 level is 2V. If input terminal AI1 is 0V, the internal reference frequency of terminal AI1 will be 20 %

04-05=11: Positive torque limit

Multi-function analog input AI2 can be used to adjust the positive torque limit.

04-05=12: Negative torque limit

Multi-function analog input AI2 can be used to adjust the negative torque limit.

04-05=13: Regenerative torque limit

Multi-function analog input AI2 can be used to adjust the regenerative torque limit.

04-05=14: Positive / negative torque limits

Multi-function analog input AI2 can be used to adjust both the positive and negative torque limit.

For more details on torque limits, please refer to parameter group 21 - torque control group.

04-05=15: Torque limit of speed control

Multi-function analog input AI2 can be used to adjust the torque limit in closed loop vector mode.

04-05=16: Torque compensation of speed control

Multi-function analog input AI2 can be used to adjust the torque compensation in closed loop vector mode.

For more details on the torque control functions, please refer to parameter group 21 - torque control group.

| 04-11 | AO1 Function Setting |
|-------|---|
| Range | 【0】 : Output Frequency 【1】 : Frequency Reference 【2】 : Output Voltage 【3】 : DC Voltage 【4】 : Output Current 【5】 : Output KW 【6】 : Motor Speed 【7】 : Output PF (Power Factor) 【8】 : AI1 Input 【9】 : AI2 Input 【10】 : Torque Command 【11】 : q-axis Current 【12】 : d-axis Current 【13】 : Speed Deviation 【14】 : Reserved 【15】 : ASR Output 【16】 : Reserved 【17】 : q-axis Voltage 【18】 : d-axis Voltage 【19】 ~ 【20】 : Reserved 【21】 : PID Input 【22】 : PID Output 【23】 : PID Setpoint 【24】 : PID Feedback Value 【25】 : Output Frequency of the Soft Starter 【26】 : Reversed 【27】 : Reversed 【28】 : Communication Control |
| 04-12 | AO1 Gain |
| Range | 【0.0~1000.0】 % |

| | | | | | | | | | |
|------------------|---|-----------------|-----------|-----------------|------------|------------------|-----------|------------------|------------|
| 04-13 | AO1 Bias | | | | | | | | |
| Range | 【-100.0~100.0】 % | | | | | | | | |
| 04-16 | AO2 Function Setting | | | | | | | | |
| Range | Setting range and definition are the same as those of 04-11. | | | | | | | | |
| 04-17 | AO2 Gain | | | | | | | | |
| Range | 【0.0~1000.0】 % | | | | | | | | |
| 04-18 | AO2 Bias | | | | | | | | |
| Range | 【-100.0~100.0】 % | | | | | | | | |
| 04-19 | AO Output Source Type Selection | | | | | | | | |
| Range | <table border="0"> <tr> <td>【0】 : AO1 0~10V</td> <td>AO2 0~10V</td> </tr> <tr> <td>【1】 : AO1 0~10V</td> <td>AO2 4~20mA</td> </tr> <tr> <td>【2】 : AO1 4~20mA</td> <td>AO2 0~10V</td> </tr> <tr> <td>【3】 : AO1 4~20mA</td> <td>AO2 4~20mA</td> </tr> </table> | 【0】 : AO1 0~10V | AO2 0~10V | 【1】 : AO1 0~10V | AO2 4~20mA | 【2】 : AO1 4~20mA | AO2 0~10V | 【3】 : AO1 4~20mA | AO2 4~20mA |
| 【0】 : AO1 0~10V | AO2 0~10V | | | | | | | | |
| 【1】 : AO1 0~10V | AO2 4~20mA | | | | | | | | |
| 【2】 : AO1 4~20mA | AO2 0~10V | | | | | | | | |
| 【3】 : AO1 4~20mA | AO2 4~20mA | | | | | | | | |

For the analog output and related parameters, refer to Fig.4.3.40.

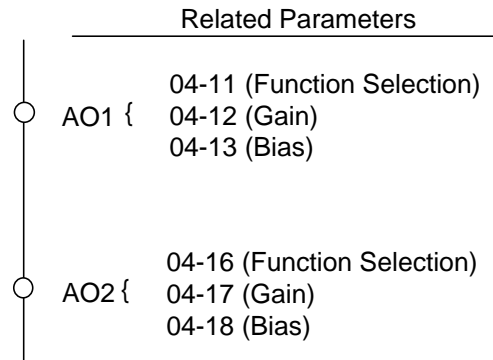

Figure 4.3.40 Analog outputs and related parameters

Analog output AO1 and AO2 adjustment (04-12, 04-13 and 04-17, 04-18)

Signal: Use parameter 04-11 to select the analog output signal for AO1 and parameter 04-16 to select the analog output signal for AO2.

Gain: Use parameter 04-12 to adjust the gain for AO1 and parameter 04-17 to adjust the gain for AO2. Adjust the gain so that the analog output (10V/20mA) matches 100% of the selected analog output signal (04-11 for AO1 and 04-16 for AO2).

Bias: Use parameter 04-13 to adjust the bias for AO1 and parameter 04-18 to adjust the bias for AO2. Adjust the bias so that the analog output (0V/4mA) matches 0% of the selected analog output signal (04-11 for AO1 and 04-16 for AO2).

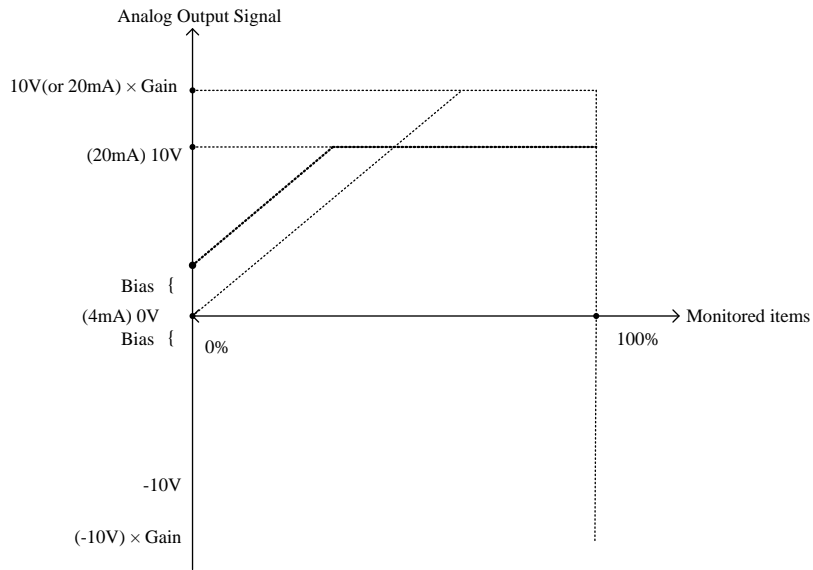

Figure 4.3.41 Analog output level adjustment

Table 4.3.9 Selection of analog output terminals function (04-11 and 04-16)

| 04-11, 04-16 Parameter setting | Function (Keypad display) | Monitoring Parameters Group 12 | Control Mode | | |
|-----------------------------------|------------------------------|-----------------------------------|--------------|-----|-----------|
| | | | VF | SLV | PM SLV |
| 0 | Output Freq | 12-17 | O | O | O |
| 1 | Freq Ref | 12-16 | O | O | O |
| 2 | Output Voltage | 12-19 | O | O | O |
| 3 | DC Voltage | 12-20 | O | O | O |
| 4 | Output Current | 12-18 | O | O | O |
| 5 | Output KW | 12-21 | O | O | O |
| 6 | Motor Speed | 12-22 | O | O | O |
| 7 | Output PF | 12-23 | O | O | O |
| 8 | AI1 Input | 12-25 | O | O | O |
| 9 | AI2 Input | 12-26 | O | O | O |
| 10 | Torque Ref | 12-27 | X | O | O |
| 11 | Current Iq | 12-28 | X | O | O |
| 12 | Current Id | 12-29 | X | O | O |
| 13 | Speed Deviation | 12-30 | X | O | O |
| 14 | Reserved | - | X | X | X |
| 15 | ASR Output | 12-32 | X | X | X |
| 16 | Reserved | - | X | X | X |
| 17 | Voltage Ref Vq | - | X | O | O |
| 18 | Voltage Ref Vd | - | X | O | O |
| 19~20 | Reserved | - | X | X | X |
| 21 | PID Input | 12-36 | O | O | O |
| 22 | PID Output | 12-37 | O | O | O |
| 23 | PID Setpoint | 12-38 | O | O | O |
| 24 | PID Feedback | 12-39 | O | O | O |
| 25 | Output Freq (SFS) | - | O | O | O |

| 04-11, 04-16 Parameter setting | Function (Keypad display) | Monitoring Parameters Group 12 | Control Mode | | |
|-----------------------------------|------------------------------|-----------------------------------|--------------|-----|-----------|
| | | | VF | SLV | PM SLV |
| 26~27 | Reserved | - | X | X | X |
| 28 | Comm Control | - | O | O | O |

| | |
|--------------|---------------------------------|
| 04-20 | Filter Time of AO Signal |
| Range | 【0.00~0.50】 Sec |

This function is used for filtering out momentary change of analog output signal.

Note: When this function is added, it will decrease the system reaction but increase interference protection.

| |
|---|
| Group 05: Multi-Speed Parameters |
|---|

| | |
|--------------|--|
| 05-00 | Acceleration and Deceleration Selection of Multi-Speed |
| Range | 【0】 : Acceleration and deceleration time are set by 00-14 ~ 00-24 (Tacc/Tdec 1~4) 【1】 : Acceleration and Deceleration Time are set by 05-17 ~ 05-48 (Independent) |

05-00=0: Standard Acceleration and deceleration times parameters 00-14 ~ 00-17 / 00-21 ~ 00-24 are used for multi-speed 0 ~ 15.

05-00=1: Each multi-speed uses a dedicated acceleration and deceleration time parameters 05-17 ~ 05-48. There are two different modes for acceleration / deceleration timing when 05-00 is set to 1, see time example on the next page.

Acceleration time calculation formula

$$\text{Time it takes to reach set frequency} = \frac{\text{Acceleration time} \times (\text{set frequency} - \text{output frequency})}{\text{Maximum output frequency}}$$

Deceleration time calculation formula

$$\text{Time it takes to reach set frequency} = \frac{\text{Deceleration time} \times (\text{output frequency} - \text{set frequency})}{\text{Maximum output frequency}}$$

Maximum output frequency: Parameter 01-00=F, maximum output frequency set by 01-02, 01-00 ≠ F, maximum output frequency determined by V/F curve selected (50.0 / 60.0 / 90.0 / 120.0 / 180.0).

Example: 01-00=01 (50Hz (maximum output frequency)), 05-02=10 Hz (multi-step speed 0), 05-17=5.0s (Acceleration time), 05-18=20.0 sec. (Deceleration time).

Acceleration time calculation formula

$$\text{Time it takes to reach set frequency} = \frac{5.0 \times 10 \text{ Hz}}{50 \text{ Hz}} = 1.0 \text{ sec.}$$

Deceleration time calculation formula

$$\text{Time it takes to reach set frequency} = \frac{20.0 \times 10 \text{ Hz}}{50 \text{ Hz}} = 4.0 \text{ sec.}$$

Example: Acceleration / deceleration timing when 05-00 is set to 1. In this example the following parameters are set:

- 00-02=1** (External Terminal Operation)
- 03-00=0** (Terminal S1: Forward /Stop)
- 03-01=1** (Terminal S2: Reversal /Stop)
- 03-02=2** (Terminal S3: Speed 1)
- 03-03=3** (Terminal S4: Speed 2)
- 03-03=4** (Terminal S5: Speed 3)

Note: When multi-step speed control is recommended to set parameter 04-05 is set to 10 (Added to AI1. When multi-step speed control is used and parameter 04-05 is set to 0 the frequency reference becomes AI2.

Acceleration / Deceleration Calculation Mode 1:

If the run command is cycled on and off, acceleration and deceleration time (a ~ f) is calculated based on the active speed command as follows:

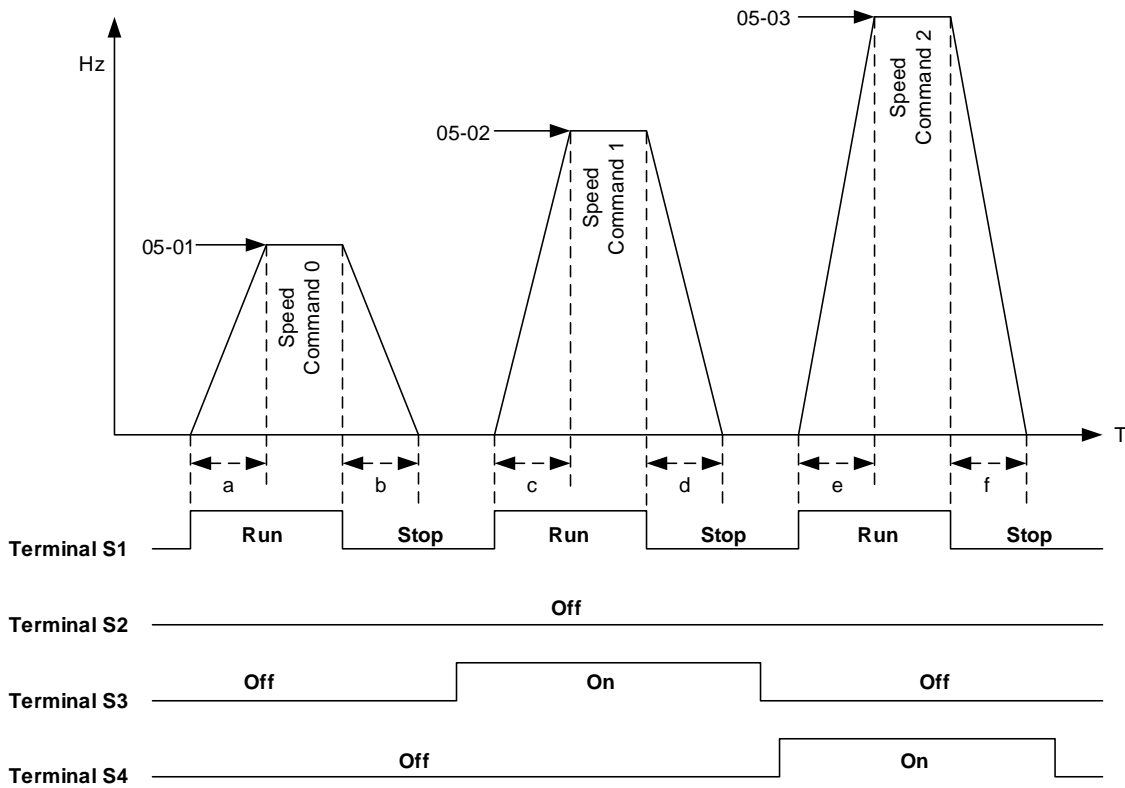

$$a = \frac{(05-17) \times (05-01)}{(01-02)} \quad b = \frac{(05-18) \times (05-01)}{(01-02)} \quad c = \frac{(05-19) \times (05-02)}{(01-02)} \quad \text{in sec.}$$

$$d = \frac{(05-20) \times (05-02)}{(01-02)} \quad e = \frac{(05-21) \times (05-03)}{(01-02)} \quad f = \frac{(05-22) \times (05-03)}{(01-02)} \quad \text{in sec.}$$

Acceleration / Deceleration Calculation Mode 2:

If the run command is remains on, acceleration and deceleration time (a ~ f) is calculated based on the active speed command as follows:

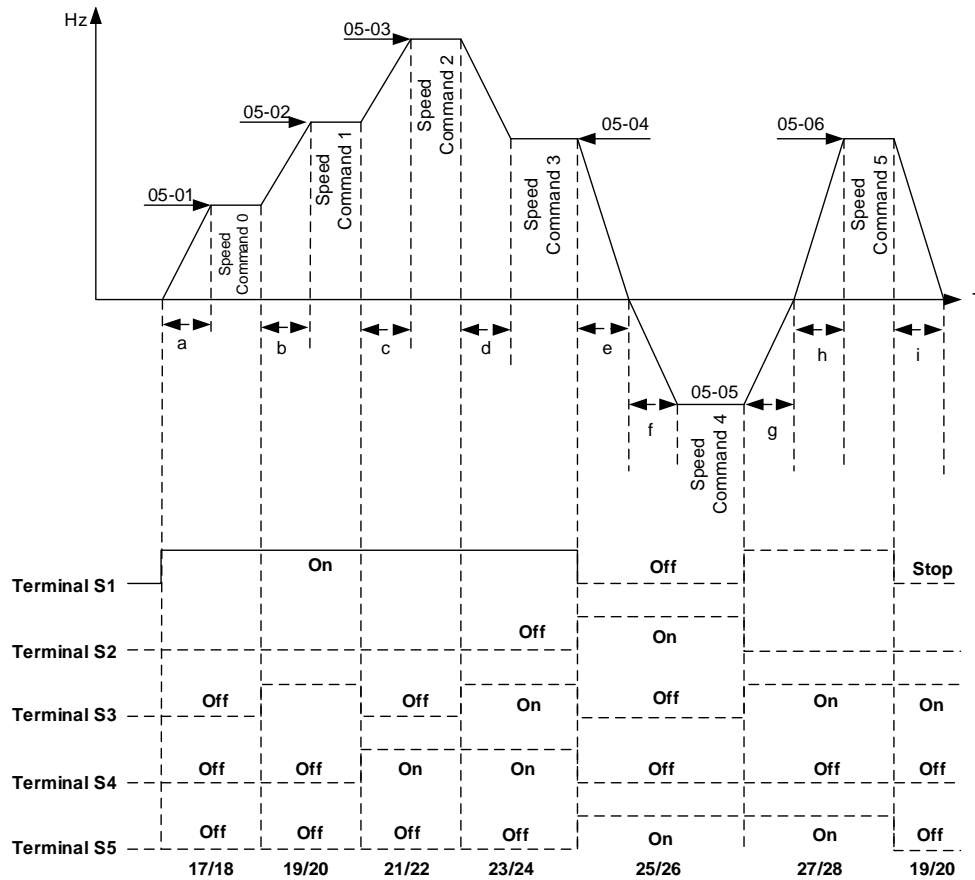

$$a = \frac{(05-17) \times (05-01)}{(01-02)} \quad b = \frac{(05-19) \times [(05-02) - (05-01)]}{(01-02)} \quad c = \frac{(05-21) \times [(05-03) - (05-02)]}{(01-02)} \quad \text{in sec.}$$

$$d = \frac{(05-24) \times [(05-03) - (05-04)]}{(01-02)} \quad e = \frac{(05-26) \times (05-04)}{(01-02)} \quad f = \frac{(05-25) \times (05-05)}{(01-02)} \quad \text{in sec.}$$

$$g = \frac{(05-27) \times (05-05)}{(01-02)} \quad h = \frac{(05-27) \times (05-06)}{(01-02)} \quad i = \frac{(05-19) \times (05-06)}{(01-02)} \quad \text{in sec.}$$

| | |
|-------|-------------------------------------|
| 05-01 | Frequency Setting of Speed- Stage 0 |
| 05-02 | Frequency Setting of Speed- Stage 1 |
| 05-03 | Frequency Setting of Speed- Stage 2 |
| 05-04 | Frequency Setting of Speed- Stage 3 |
| 05-05 | Frequency Setting of Speed- Stage 4 |
| 05-06 | Frequency Setting of Speed- Stage 5 |
| 05-07 | Frequency Setting of Speed- Stage 6 |
| 05-08 | Frequency Setting of Speed- Stage 7 |
| 05-09 | Frequency Setting of Speed- Stage 8 |
| 05-10 | Frequency Setting of Speed- Stage 9 |

| | |
|-------|--------------------------------------|
| 05-11 | Frequency Setting of Speed- Stage 10 |
| 05-12 | Frequency Setting of Speed- Stage 11 |
| 05-13 | Frequency Setting of Speed- Stage 12 |
| 05-14 | Frequency Setting of Speed- Stage 13 |
| 05-15 | Frequency Setting of Speed- Stage 14 |
| 05-16 | Frequency Setting of Speed- Stage 15 |
| Range | 【0.0~400.00】 Hz |

| | |
|-------|--|
| 05-17 | Acceleration time setting for multi speed 0 |
| 05-18 | Deceleration time setting for multi speed 0 |
| 05-19 | Acceleration time setting for multi speed 1 |
| 05-20 | Deceleration time setting for multi speed 1 |
| 05-21 | Acceleration time setting for multi speed 2 |
| 05-22 | Deceleration time setting for multi speed 2 |
| 05-23 | Acceleration time setting for multi speed 3 |
| 05-24 | Deceleration time setting for multi speed 3 |
| 05-25 | Acceleration time setting for multi speed 4 |
| 05-26 | Deceleration time setting for multi speed 4 |
| 05-27 | Acceleration time setting for multi speed 5 |
| 05-28 | Deceleration time setting for multi speed 5 |
| 05-29 | Acceleration time setting for multi speed 6 |
| 05-30 | Deceleration time setting for multi speed 6 |
| 05-31 | Acceleration time setting for multi speed 7 |
| 05-32 | Deceleration time setting for multi speed 7 |
| 05-33 | Acceleration time setting for multi speed 8 |
| 05-34 | Deceleration time setting for multi speed 8 |
| 05-35 | Acceleration time setting for multi speed 9 |
| 05-36 | Deceleration time setting for multi speed 9 |
| 05-37 | Acceleration time setting for multi speed 10 |
| 05-38 | Deceleration time setting for multi speed 10 |
| 05-39 | Acceleration time setting for multi speed 11 |
| 05-40 | Deceleration time setting for multi speed 11 |
| 05-41 | Acceleration time setting for multi speed 12 |
| 05-42 | Deceleration time setting for multi speed 12 |
| 05-43 | Acceleration time setting for multi speed 13 |
| 05-44 | Deceleration time setting for multi speed 13 |
| 05-45 | Acceleration time setting for multi speed 14 |
| 05-46 | Deceleration time setting for multi speed 14 |
| 05-47 | Acceleration time setting for multi speed 15 |
| 05-48 | Deceleration time setting for multi speed 15 |
| Range | 【0.1~6000.0】 Sec |

Group 06: Automatic Operation Parameters

| 06-00 | Automatic Operation Mode Selection |
|-------|---|
| Range | <p>【0】 : Disable</p> <p>【1, 4】 : Execute a single cycle operation.</p> <p>【2, 5】 : Execute continuous cycle operation.</p> <p>【3, 6】 : After completion of a single cycle, the on-going operation speed is based on the speed of the last stage.</p> <p>1 to 3: After a stop the inverter will continue where it left off when run command is re-applied.</p> <p>4 to 6: After a stop the inverter will start at step 1 when run command is re-applied.</p> |

Automatic operation mode uses frequency reference parameters 05-01, 06-01~06-15, operation time parameters 06-16 ~ 06-31 and direction of operation parameters 06-32~06-47.

Note: The automatic operation mode is disabled when any of the following functions are enabled:

- Frequency wobbling function
- PID function
- Parameters 06-16 to 06-31 are set to 0.

Notes:

- When automatic operation mode is enabled multi-step speed reference command 1~4 (03-00~03-07=2~5) is disabled.
- Frequency of multi-step speed 0 is set by 05-01.
- Acceleration/deceleration time is set by parameter 00-14 and 00-15 in automatic operation mode.

| Automatic operation frequency reference settings | |
|--|--------------------------------------|
| 06-01 | Frequency Setting of Speed-Stage 1 |
| 06-02 | Frequency Setting of Speed -Stage 2 |
| 06-03 | Frequency Setting of Speed -Stage 3 |
| 06-04 | Frequency Setting of Speed -Stage 4 |
| 06-05 | Frequency Setting of Speed -Stage 5 |
| 06-06 | Frequency Setting of Speed -Stage 6 |
| 06-07 | Frequency Setting of Speed -Stage 7 |
| 06-08 | Frequency Setting of Speed -Stage 8 |
| 06-09 | Frequency Setting of Speed -Stage 9 |
| 06-10 | Frequency Setting of Speed -Stage 10 |
| 06-11 | Frequency Setting of Speed -Stage 11 |
| 06-12 | Frequency Setting of Speed -Stage 12 |
| 06-13 | Frequency Setting of Speed -Stage 13 |
| 06-14 | Frequency Setting of Speed -Stage 14 |
| 06-15 | Frequency Setting of Speed -Stage 15 |
| Range | 0.00~400.00 Hz |

| Automatic operation time settings | |
|-----------------------------------|--|
| 06-16 | Operation Time Setting of Speed-Stage 0 |
| 06-17 | Operation Time Setting of Speed-Stage 1 |
| 06-18 | Operation Time Setting of Speed-Stage 2 |
| 06-19 | Operation Time Setting of Speed-Stage 3 |
| 06-20 | Operation Time Setting of Speed-Stage 4 |
| 06-21 | Operation Time Setting of Speed-Stage 5 |
| 06-22 | Operation Time Setting of Speed-Stage 6 |
| 06-23 | Operation Time Setting of Speed-Stage 7 |
| 06-24 | Operation Time Setting of Speed-Stage 8 |
| 06-25 | Operation Time Setting of Speed-Stage 9 |
| 06-26 | Operation Time Setting of Speed-Stage 10 |
| 06-27 | Operation Time Setting of Speed-Stage 11 |
| 06-28 | Operation Time Setting of Speed-Stage 12 |
| 06-29 | Operation Time Setting of Speed-Stage 13 |
| 06-30 | Operation Time Setting of Speed-Stage 14 |
| 06-31 | Operation Time Setting of Speed-Stage 15 |
| Range | 0.0~6000.0 Sec |

| Automatic operation direction settings | |
|--|---|
| 06-32 | Operation Direction Selection of Speed-Stage 0 |
| 06-33 | Operation Direction Selection of Speed-Stage 1 |
| 06-34 | Operation Direction Selection of Speed-Stage 2 |
| 06-35 | Operation Direction Selection of Speed-Stage 3 |
| 06-36 | Operation Direction Selection of Speed-Stage 4 |
| 06-37 | Operation Direction Selection of Speed-Stage 5 |
| 06-38 | Operation Direction Selection of Speed-Stage 6 |
| 06-39 | Operation Direction Selection of Speed-Stage 7 |
| 06-40 | Operation Direction Selection of Speed-Stage 8 |
| 06-41 | Operation Direction Selection of Speed-Stage 9 |
| 06-42 | Operation Direction Selection of Speed-Stage 10 |
| 06-43 | Operation Direction Selection of Speed-Stage 11 |
| 06-44 | Operation Direction Selection of Speed-Stage 12 |
| 06-45 | Operation Direction Selection of Speed-Stage 13 |
| 06-46 | Operation Direction Selection of Speed-Stage 14 |
| 06-47 | Operation Direction Selection of Speed-Stage 15 |
| Range | 0: Stop, 1: Forward, 2: Reversal |

Example 1: Automatic operation mode – Single cycle

In this example the inverter executes a single cycle and then stops.

Parameter Settings:

- 06-00 = 1 (Single cycle operation)
- 06-32~06-34 = 1 (Forward for operation stage 0 - 2)
- 06-47 = 2 (Reversal for operation stage 15)
- 06-35~06-46 = 0 (Stop for operation frequency stage 3 - 14)
- 05-01 = 15 Hz (Operation frequency stage 0: 15 Hz)
- 06-01 = 30 Hz (Operation frequency stage 1: 30 Hz)
- 06-02 = 50 Hz (Operation frequency stage 2: 50 Hz)
- 06-15 = 20 Hz (Operation frequency stage 15: 20 Hz)
- 06-16 = 20 sec (Operation time stage 0: 20 sec)
- 06-17 = 25 sec (Operation time stage 1: 25 sec)
- 06-18 = 30 sec (Operation time stage 2: 30 sec)
- 06-31 = 40 sec (Operation time stage 15 :40 sec)

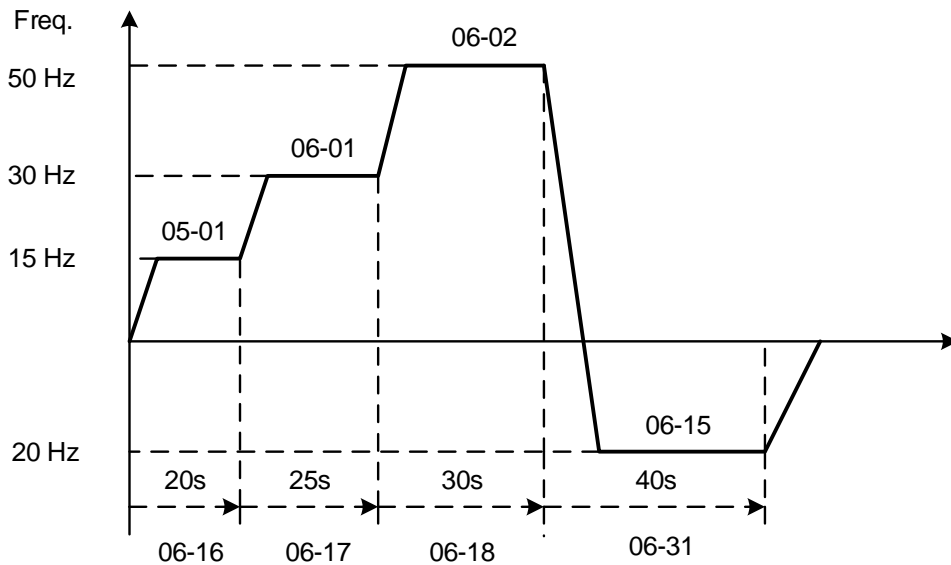

Figure 4.3.42 Single cycle automatic operation (stop)

Example 2: Automatic operation mode – Continuous cycle

In this example the inverter repeats the same cycle.

Parameter Settings:

06-00 = 2 or 5 (Continuous cycle operation)

06-01~06-47= Enter same setting as that of Example 1.

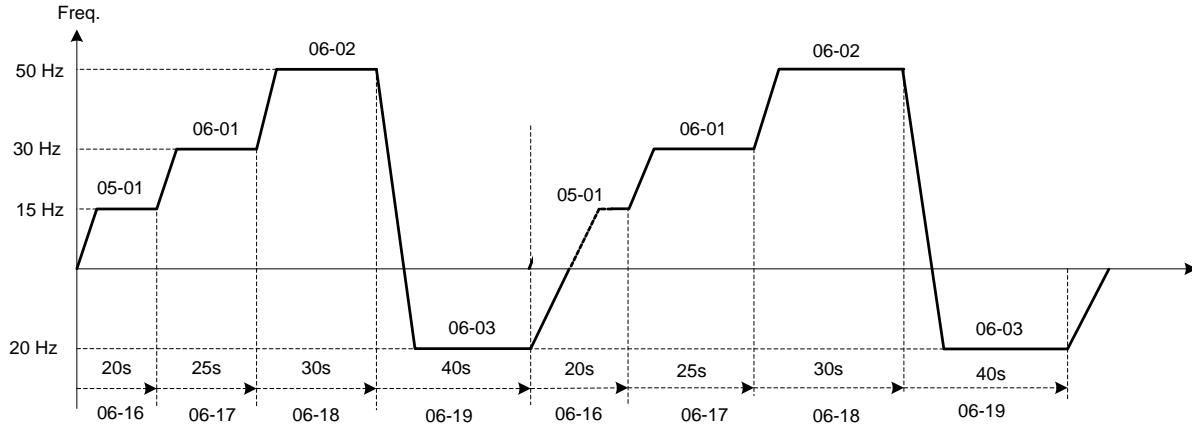

Figure

4.3.43 Periodic automatic operation

Example 3: Automatic operation mode – Single cycle and continue running at last speed of the cycle

In this example the inverter executes a single cycle and continue running at last speed of the cycle.

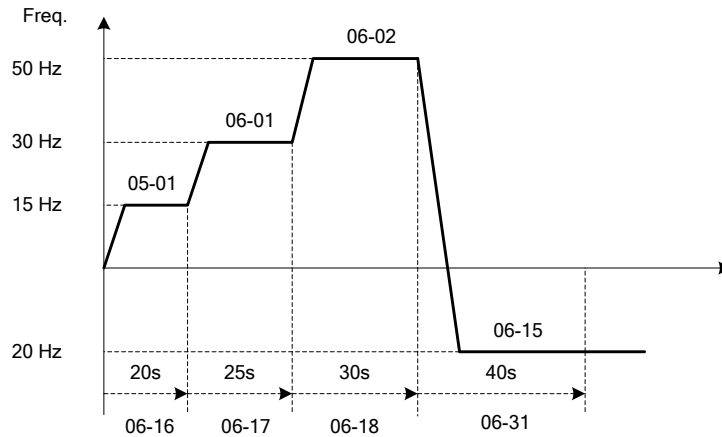

Figure 4.3.44 Single cycle automatic operation (continuous)

06-00= 1 to 3:

After a stop the inverter will start with the incomplete step when the run command is re-applied.

06-00= 4 to 6:

After a stop the inverter will start with the first step of the cycle when the run command is re-applied.

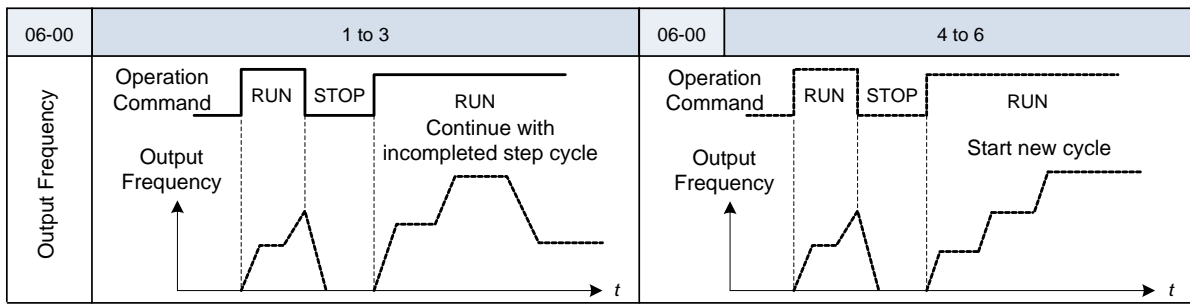

Notes:

- Acceleration/ deceleration time is set with parameters 00-14 and 00-15 in automatic operation mode.
- If the setting value of parameters 06-16-06-31 is 0, automatic operation mode is not active.

| |
|---|
| Group 07: Start /Stop Parameters |
|---|

| | |
|--------------|---|
| 07-00 | Momentary Power Loss/Fault Restart Selection |
| Range | 【0】 : Disable 【1】 : Enable |

07-00=0: Inverter trips on “UV” fault if power loss time is greater than 8ms.
07-00=1: Inverter restarts after restarting the power at the momentary power loss.

Note: When 07-00=1, inverter restores motor operation when is re-applied even if momentary power loss has occurred.

| | |
|--------------|--------------------------------|
| 07-01 | Fault Auto-Restart Time |
| Range | 【0~7200】 Sec |

07-01 = 0 sec.: Automatic restart time interval is set by minimum baseblock time (07-18).
 07-01 <07-18: Automatic restart time interval is set by minimum baseblock time (07-18).
 07-01 > 07-18: Automatic restart time interval is set by fault reset time (07-01).

Note:
 Automatic restart time interval is defined by time set in 07-18 plus 07-01 and the speed search delay time (07-22).

Refer to Fig.4.3.45 for setting automatic restart interval.

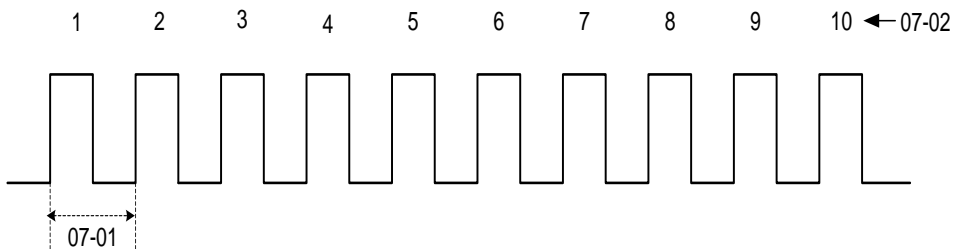

Figure 4.3.45 Automatic restart operation

| | |
|--------------|--|
| 07-02 | Number of Fault Auto-Restart Attempts |
| Range | 【0~10】 |

When the automatic restart function is enabled the internal automatic restart attempt counter is reset based on the following actions:

- a) No fault occurs in 10 minutes or longer after the automatic restart
- b) Reset command to clear fault via input terminal or using the keypad (ex: press reset/ ◀ key)
- c) Power to the inverter is turned off and back on again

Note:
 Multi-function digital output R1A-R1C, R2A-R2C, R3A-R3C can be programmed to activate during an automatic reset attempt, refer to parameter 03-11, 03-12 and 03-39.

Automatic restart operation:

- a) Fault is detected. The inverter turn off the output, displays the fault on the keypad and waits for the minimum

baseblock time parameter 07-18 to expire before accepting another run / automatic restart command.

- b) After the minimum baseblock time (07-18) has expired, the active fault is reset and a speed search operation is performed. The time between each fault restart attempt is set by parameter 07-01.
- c) When the total numbers of restart attempts exceed the number of automatic restart attempts set in parameter 07-02, the inverter will turn off the output and the fault contact is activated.

Please refer to Figure 4.3.46 for the automatic restart operation.

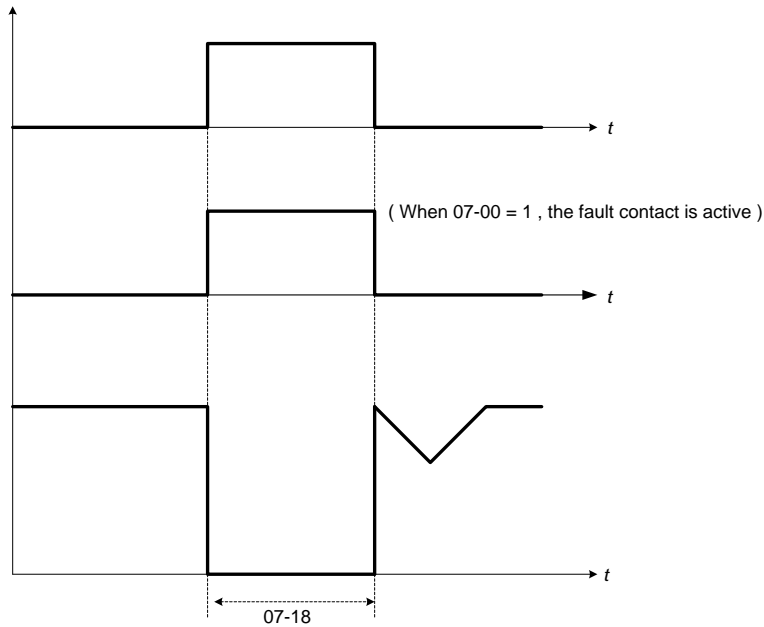

Figure 4.3.46 Auto-restart operation

The automatic restart function is active for the following faults. Please note that when the fault is not listed in the table the inverter will not attempt an automatic restart.

| Parameter Name | Faults | | Numbers of Restart |
|----------------|---|--|-----------------------------------|
| 07-00 | UV (under voltage) | | Unlimited |
| 07-01 | OC (over current) OL1 (motor overload) UT (Under torque detection) | OV (overvoltage) OL2 (Inverter overload) OT (Over-torque detection) | Depends on parameter 07-02 |
| 07-02 | IPL (input phase loss) GF (ground failure) | OPL (Output phase loss) | |

Notes:

- 1. Fault restart function contains momentary power loss restart and auto reset restart.
- 2. Refer to chapter 10 for troubleshooting and fault diagnostics.
- 3. Refer to speed search function (07-19~07-24) for information on the available speed search modes.

Note:

Automatic restart function is only active in the state of no harm to the safety or to the application devices.

Warning - Excessively use of the automatic restart function can damage the inverter.

| | |
|--------------|--|
| 07-04 | Direct Start at Power Up |
| Range | 【0】 : Enable (Start inverter when run signal is active at power-up) 【1】 : Disable |

07-04 = 0:

Starts inverter (run motor) when signal run is present at power-up.

07-04 =1:

Inverter will not start when run signal is active at power-up (STP1 will flash). To run the inverter remove the run command signal and re-apply run command again.

| | |
|--------------|-----------------------------------|
| 07-05 | Delay Time of Direct Start |
| Range | 【1.0~300.0】 Sec |

When 07-04 = 0, the inverter (run motor) will start when signal run is present at power-up after timer specified by parameter 07-05 has expired.



Warning:

- When run signal is active, 07-04 = 0 and run command source is set to external control (00- 02/00- 03 = 1) it is recommended to remove run command at power down to prevent damage to the drive and injury to the user.

| | |
|--------------|--|
| 07-06 | DC Injection Braking Starting Frequency |
| Range | 【0.0~10.0】 Hz |

DC injection braking start frequency is the level the output frequency has to reach before DC braking injection function is activated.

| | |
|--------------|-------------------------------------|
| 07-07 | DC Injection Braking Current |
| Range | 【0~100】 % |

DC Injection braking current as percentage of the inverter rated current. Increasing this level will increase the amount of heat generated by the motor windings. Do not set this parameter higher than the level necessary to hold the motor shaft.

| | |
|--------------|--|
| 07-08 | DC Injection Braking Time at Stop |
| Range | 【0.00~10.00】 Sec |

Duration of DC injection braking is during a stop operation. DC injection braking at stop is disabled when parameter 07-08 is set to 0 sec.

| | |
|--------------|---|
| 07-16 | DC Injection Braking Time at Start |
| Range | 【0.00~100.00】 Sec |

Duration of DC injection braking is during a start operation. DC injection braking at start is disabled when parameter 07-16 is set to 0 sec.

DC Injection Braking Operation

When DC Injection braking is active DC voltage is applied to the motor, increasing the braking current and resulting in an increase in the strength of the magnetic field trying to lock the motor shaft.

To enable DC injection braking during a start operation set the DC injection braking current (07-07) and the DC injection braking time (07-16) at start to a value greater than 0. DC injection braking at start can be used to prevent “wind milling effect” in fan applications.

To enable DC injection braking during a stop operation set the DC injection braking current (07-07) and the DC injection braking time at stop (07-08) to a value greater than 0.

Notes:

- When parameter 07-16 is set to 0 sec. the inverter will start from the minimum output frequency.
- Increasing the DC braking time (07-08, 07-16) can reduce the motor stop time.
- Increasing the DC braking current (07-07) can reduce the motor stop time.
- During stop operation: If the DC braking start frequency < minimum output frequency (01-08), DC braking is activated when the output frequency reaches the minimum output frequency level.
- DC Injection braking cannot be used in sensor vector control (SV).

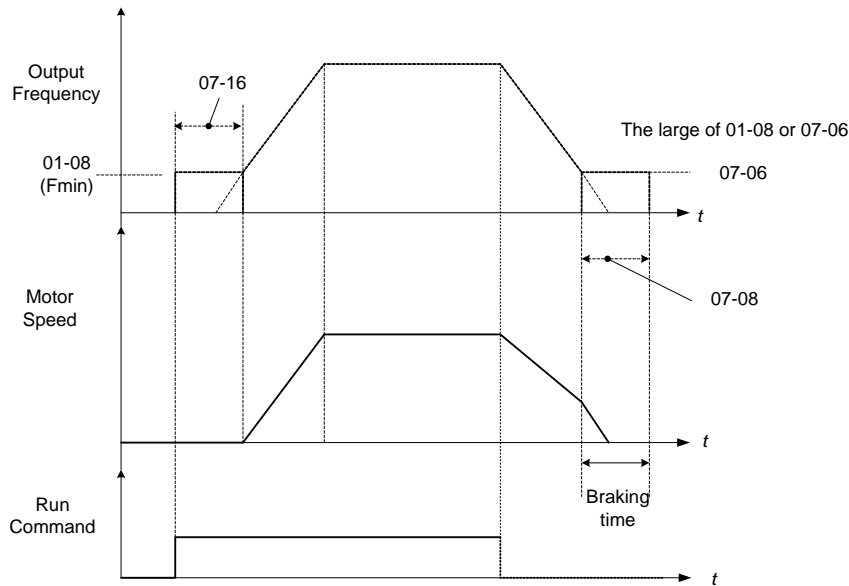

Figure 4.3.47 DC braking operation

DC braking operation can be controlled via any one of the multi-function input terminals (03-00 to 05) function 33. Refer to Fig. 4.3.47 for DC braking operation.

DC braking current can be controlled via the multi-function analog input (04-05) function 5. Refer to Fig. 4.3.34.

| | |
|--------------|---|
| 07-09 | Stop Mode Selection |
| Range | <p>【0】 : Deceleration to Stop</p> <p>【1】 : Coast to Stop</p> <p>【2】 : DC Braking Stop</p> <p>【3】 : Coast to Stop with Timer</p> |

When a stop command is issued the inverter stops according to the stop mode selected. There are four types of stop modes,

Note: When using the permanent magnet motor, only the option of deceleration to stop mode is available.

07-09=0: Deceleration to stop

When a stop command is issued, the motor will decelerate to the minimum output frequency (01-08) F_{min} and then stop. Deceleration rate depends on the deceleration time (factory default: 00-15).

When the output frequency reaches the DC braking stop frequency (07-06) or the minimum output frequency (01-08), DC injection braking is activated and the motor stops.

$$\text{Deceleration time} = \frac{\text{Output frequency when stop command is issued}}{\text{Maximum output frequency } F_{max} \text{ (01-02)}} \times \text{deceleration time setting}$$

Note: S curve setting will add to the overall stop time

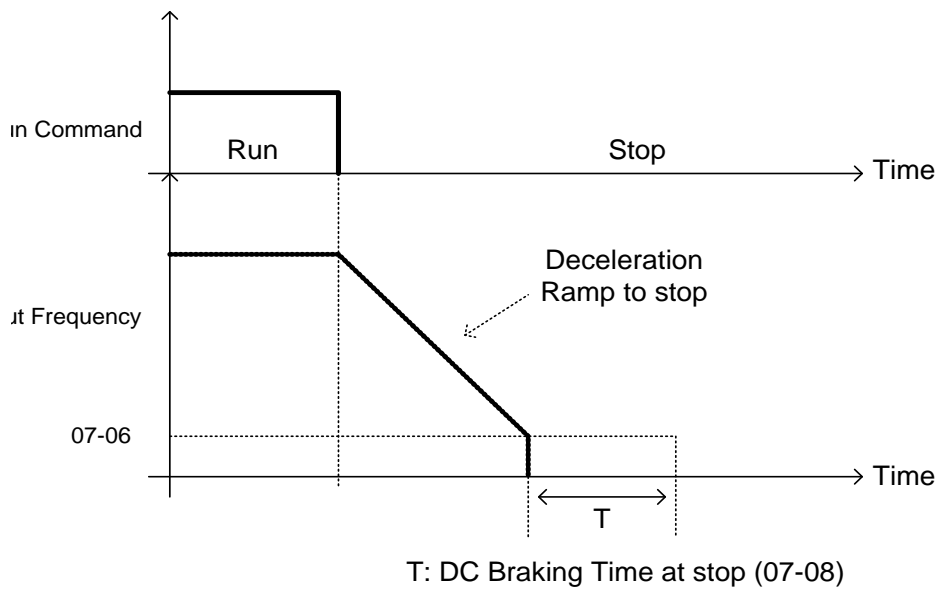

Figure 4.3.48 Deceleration to stop

07-09=1: Coast to stop

When a stop command is issued, the motor will coast to a stop. Stop time depends on motor load and friction of the system.

The inverter waits for the time set in the minimum baseblock time (07-18) before accepting the next run command.

In SLV mode (00-00=2) the speed search function is automatically enabled upon the next run command.

Note: When using a mechanical brake set parameter 07-26 to 1.

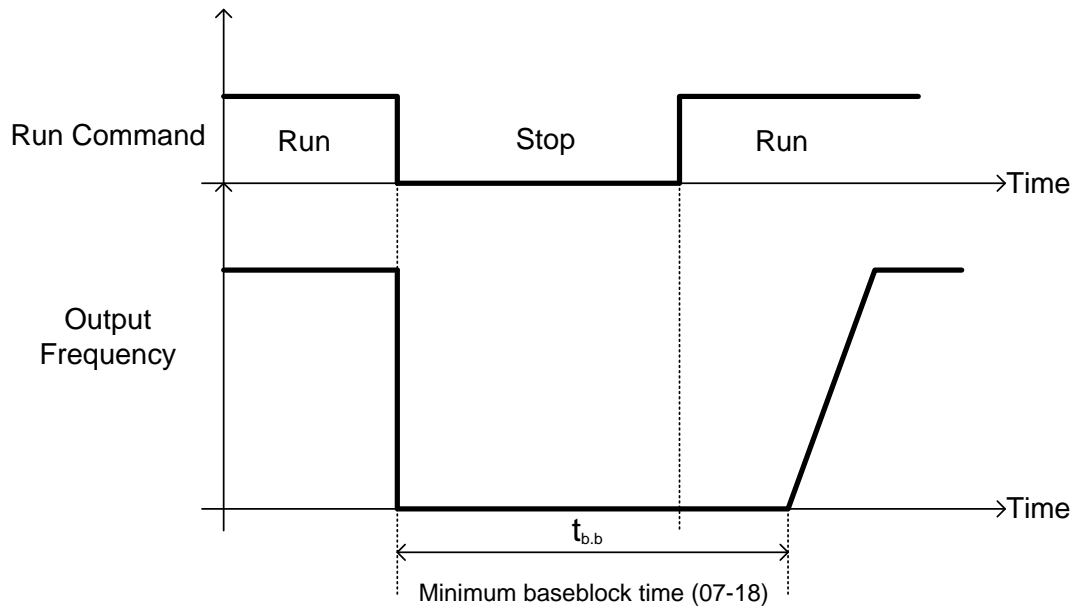

Figure 4.3.49 Coast to stop

07-09=2: DC braking to stop

When a stop command is issued, the inverter will turn off the output (Baseblock) and after the minimum Baseblock time (07-18) has expired activate DC braking (07-07). Refer to Fig.4.3.50.

The DC braking time (t_{DCDB}) of Figure 4.3.50 is determined by the value of 07-08 (DC Braking start time) and the output frequency at the time the stop command was issued.

$$t_{DCDB} = \frac{(07-08) \times 10 \times \text{output frequency}}{F_{max} (01-02)}$$

Note: Increase the minimum Baseblock time (07-18) in case an Overcurrent trip occurs during the DC braking.

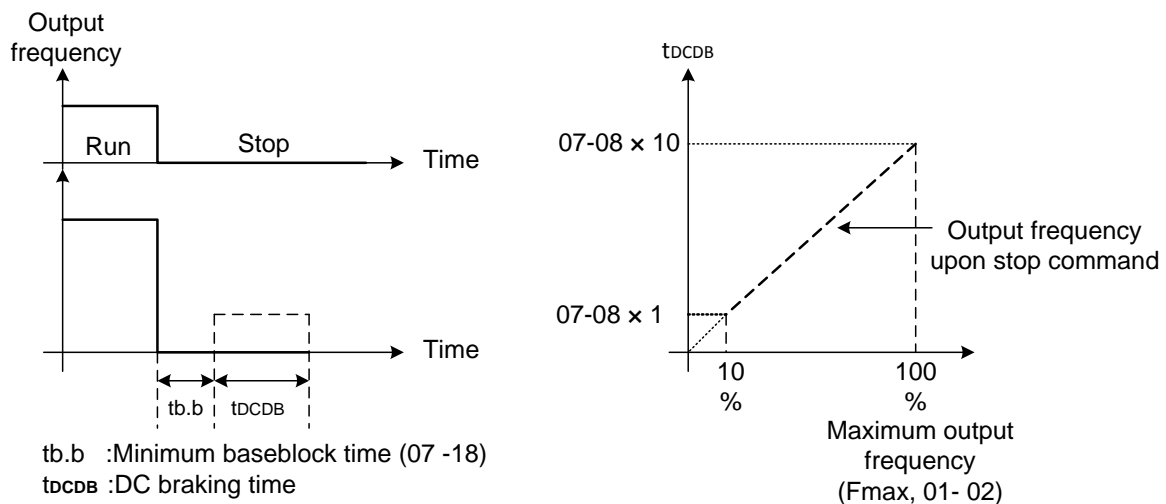
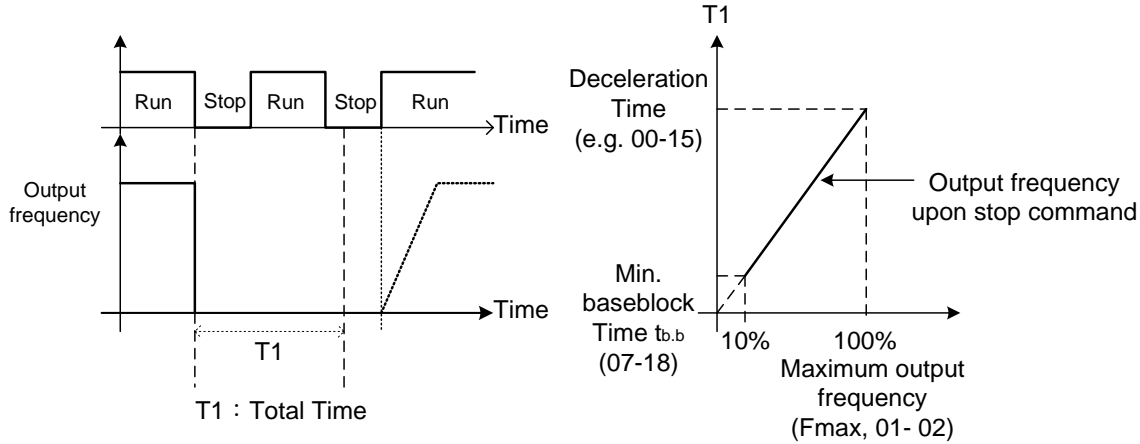

Figure 4.3.50 DC braking to stop

07-09=3: Coast to stop with timer

When a stop command is issued the motor will coast to a stop after the minimum Baseblock time (07-18) has expired. The inverter ignores the run command until the total time of the timer has expired.

The total time of the timer is determined by the deceleration time (00-15, 17, 22 or 24) and the output frequency upon stop. Refer to Fig.4.3.51



Figure

4.3.51 Coast to stop with timer

| | |
|--------------|--|
| 07-13 | Low Voltage Detection Level |
| Range | 【230V】 : 150~300V 【460V】 : 300~600V |
| 07-25 | Low voltage Detection Time |
| Range | 【0.00~1.00】 Sec |

Adjust the 07-13 voltage level from 150 to 300 Vdc (for 230V series) or from 300 to 600 Vdc (for 460V series).

When the AC input voltage is lower than the 07-13 value ($07-13 / 1.414 =$ AC voltage detection level) for the time specified in 07-25 the low-voltage error "UV" will displayed. If 07-25 = 0.00 sec., the UV error will be displayed immediately.

Set preventive measures:

- The inverter input voltage will limit the output voltage. If the input voltage drops excessively, or if the load is too big, the motor may stall.
- If the input voltage drops below the value set in 07-13 then the output is turned off momentarily. The inverter will not automatically start when power is restored.

| | |
|--------------|-----------------------------|
| 07-14 | Pre-excitation Time |
| Range | 【0.00~10.00】 Sec |
| 07-15 | Pre-excitation Level |
| Range | 【50~200】 % |

If a high starting torque is required for the application, especially for a large horsepower motors, the pre-excitation operation can be used to pre-flux (magnetize) the motor.

07-14: Pre-excitation time

When an operation command (forward or reverse) is activated, the inverter will automatically start pre-excitation based on the time set in parameter 07-14.

The time for the flux to reach 100% is a function value of motor's electrical time constant (See figure 4.3.52).

Electrical time constant (quadratic by-pass circuit time constant) can be calculated by motor parameter setting (group 02)

$$\text{Electrical time constant } T2 = \frac{\text{Motor leakage inductance (02-17) + motor mutual inductance (02-18)}}{\text{Motor rotor resistance (02-16)}}$$

Set the pre-excitation time (07-14) based on the electrical time constant T2

07-15: Pre-excitation initial level

Use the pre-excitation initial level (07-15) to provide a higher excitation current during the pre-excitation time (07-14), which will increase the speed and stability for motors.

In order to quickly magnetize the motor, reduce the pre-excitation time (07-14) and set the pre-excitation level (07-15) to a high level.

If 07-15 is set greater than 100%, providing a high excitation current during the pre-excitation time (07-14), motor's magnetization time is shortened. When the setting reaches 200%, magnetization is reduced by roughly half.

A high pre-excitation level (07-15) might result in excessive motor sound during pre-excitation.

When the flux reaches 100%, pre-excitation current reverts back to 100% and pre-excitation is completed.

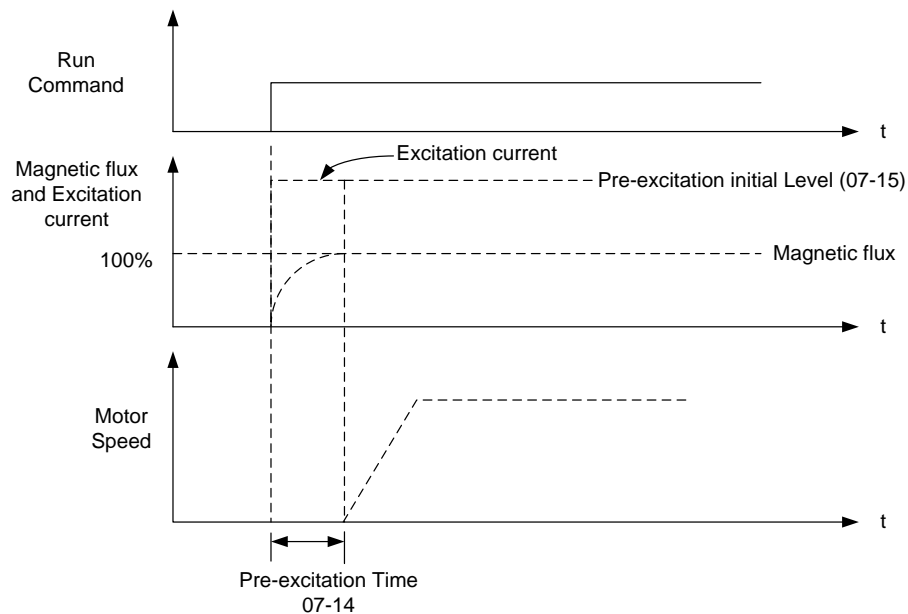

Figure 4.3.52 Pre-excitation operation

| | |
|--------------|--------------------------------|
| 07-18 | Minimum Base block Time |
| Range | 【0.1~5.0】 Sec |

In case of a momentary power failure, the inverter continues to operate after the power has been restored when parameter 07-00 is set to 1. Once the momentary power failure is detected; the inverter will automatically shut down the output and maintain B.B for a set time (07-18).

It is expected that after the minimum base block time has expired the residual voltage to be almost zero.

When the momentary power failure time exceeds the minimum base block time (07-18), the inverter will automatically perform a speed search upon return of power. Refer to the following figure 4.3.53.

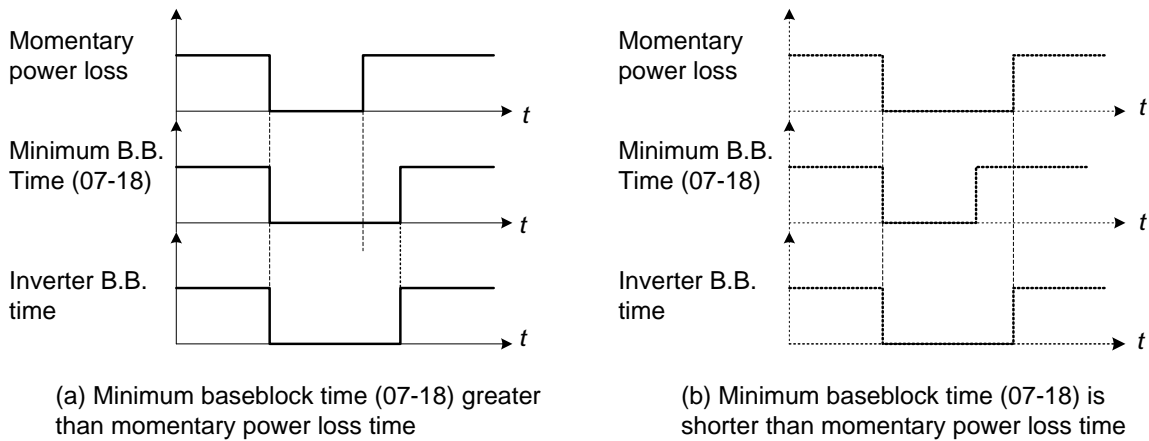

Figure 4.3.53 Minimum B.B time and momentary power loss time

Minimum base block time (07-18) is also used to for the DC braking function in combination with speed search as follows:

- Set the minimum base block time required (07-18).
- Execute speed search or DC braking function.
- Increase minimum Baseblock time if over-current "OC" condition occurs.
- After speed search is completed, normal operation continues.

| | |
|--------------|---|
| 07-19 | Bi-Direction-Detection Speed Search Operating Current |
| Range | 【0~100】 % |
| 07-20 | One Direction-Detection Speed Search Operating Current |
| Range | 【0~100】 % |
| 07-21 | Integral Time of Speed Searching |
| Range | 【0.1~10.0】 Sec |
| 07-22 | Delay Time of Speed Search |
| Range | 【0.0~20.0】 Sec |
| 07-23 | Voltage Recovery Time |
| Range | 【0.1~5.0】 Sec |

| | |
|--------------|--|
| 07-24 | Bi-Direction-Detection Speed Search Selection |
| Range | 【0】 : Disable 【1】 : Enable |
| 07-26 | Start Selection after Coast to Stop during SLV mode |
| Range | 【0】 : Speed search start 【1】 : Normal Start |
| 07-27 | Start Selection after Fault during SLV Mode |
| Range | 【0】 : Speed search start 【1】 : Normal Start |
| 07-28 | Start after External Base Block |
| Range | 【0】 : Speed search start 【1】 : Normal Start |

Speed search function is used to find the speed of a coasting motor and continue operation from that point. The speed search function is active after a momentary power loss.

Speed Search from Multi-function digital inputs

Set the multi-function digital input to external speed search command 1 or 2. External speed search command 1 (value = 19) and 2 (value = 34) cannot be set at the same time, otherwise "SE02" (digital input terminal error) warning occurs.

Speed search function must be enabled before applying the run command to ensure proper operation. See relay logic in Fig. 4.3.54.

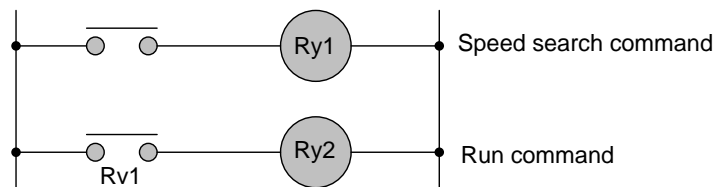

Figure 4.3.54 Speed search and operation commands

Notes: Speed Search Operation

- The speed search cannot be used when the motor rated power is greater than the inverter rated power.
- The speed search cannot be used when the motor rated power is two inverter sizes smaller than the inverter currently used.
- The speed search cannot be used in combination with a high-speed motor.
- In V/F mode, it is necessary to perform a static auto-tune.
- In SLV mode, it is necessary to perform a rotational auto-tune. Perform a static auto-tune when using long motor leads.

Speed search uses current detecting. Use parameter 07-24 to select detection direction.

07-19: Speed Direction Search Operating Current

- Used in bidirectional speed search only (07-24 = 1).
- Set bidirectional current level.

- Increase value if speed search is not successful at low speeds (above 5Hz)

Note: If value is too high may cause DC braking effect.

07-20: Speed Search Operating Current

- Can be used for bidirectional (07-24 = 1) or unidirectional (07-24 = 0) speed search.
- Sets speed search current Level.
- The set value must be lower than the excitation current (02-09) and must equal to the no-load current. If the no-load current is unknown it is recommended to set value at 20%.
- Excessive speed search current will cause inverter output to saturate.
- It is recommended to use speed search in case of a momentary power loss. Increase the minimum base block time (07-18) in case of an over-current condition.

07-21: Integral time of speed searching

- Can be used for bidirectional (07-24 = 1) or unidirectional (07-24 = 0) speed search.
- Set the integral time during speed search.
- If OV occurs, increase the set value to increase the speed search time. Decrease the value if a quick start is required

07-22: Delay time of speed search

- Use delay time when using a contactor on the inverter output side.
- The inverter speed search starts after the delay time expires.
- Speed search delay time is disabled when set to 0.0 sec. (07-22 = 0.0)

07-23: Voltage recovery time

- Sets the voltage recovery time.
- Sets the time for the inverter to restore the output voltage from 0V to the specified V/f level after speed search function is completed.

07-24: Direction-Detection Speed Search Selection

07-24=0: Disable Direction-Detection Speed Search

Speed search is executed using speed search operating current defined in parameter 07-20. In case speed search is not successful (e.g. motor speed is too low) a speed search time-out warning is displayed. Set 07-19 to value greater than 0 to enable DC braking at speed search if a time-out occurs frequently.

07-24=1: Enable Direction-Detection Speed Search

At start the current controller will send a step current to the motor (07-19) to determine the motor direction. Once direction is determined the current controller will perform a speed search using speed search operating current defined in parameter 07-20. Speed search is executed after a momentary power loss (external speed search command 2, 03-00 to 03-05 = 34) or from max. frequency (external speed search command 1, 03-00 to 03-05 = 19). Speed search direction will follow the speed command.

07-26: SLV Speed Search Function

- In SLV mode (00-00 = 2) set the stop mode to the coast stop (07-09 = 1) or to the coast to stop with timer (07-09 = 3). After a stop command is issued (coast to stop or coast to stop with times) the speed search function is automatically activated for the next start.

07-26=0: Speed search start (No mechanical brake is installed)

07-26=1: Normal Start (Mechanical brake is installed)

07-27: Start Selection after fault during SLV mode

07-27=0: Speed search start: Speed search is executed after a fault in SLV mode.

07-27=1: Normal start: Speed search is not enabled.

Note: Set the parameter to 1 (normal start) after a fault has occurred and a mechanical brake is used to stop the motor.

07-28: Start after external Baseblock

07-28=0: Speed search start: Speed search is executed after base block is removed.

07-28=1: Normal start: Speed search is not enabled.

Notes:

- Set parameter to 1 for the control mode of SLV mode (00-00 = 2) when the external base block active time is longer than the time the motor needs to come to a complete stop. After the external base block command is removed the inverter will accelerate from min. frequency.
- The inverter has no choices but can only normally start when using permanent magnetic motor.

■ Speed search based on current detection

(a) Speed search at starting

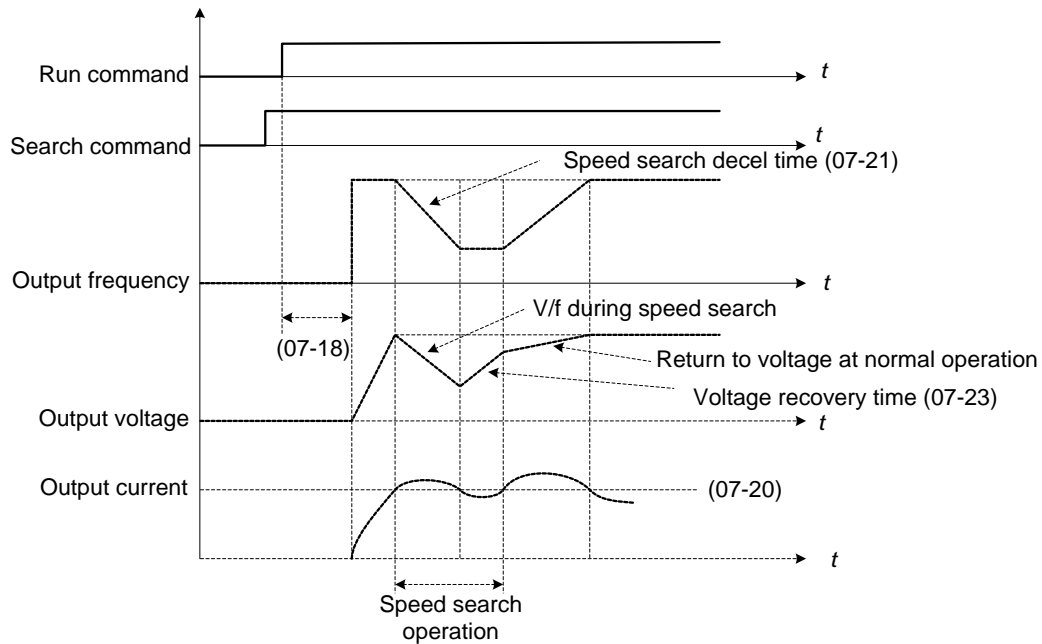

Figure 4.3.55 Speed search at starting

(b) Speed search in recovery period of momentary power failure

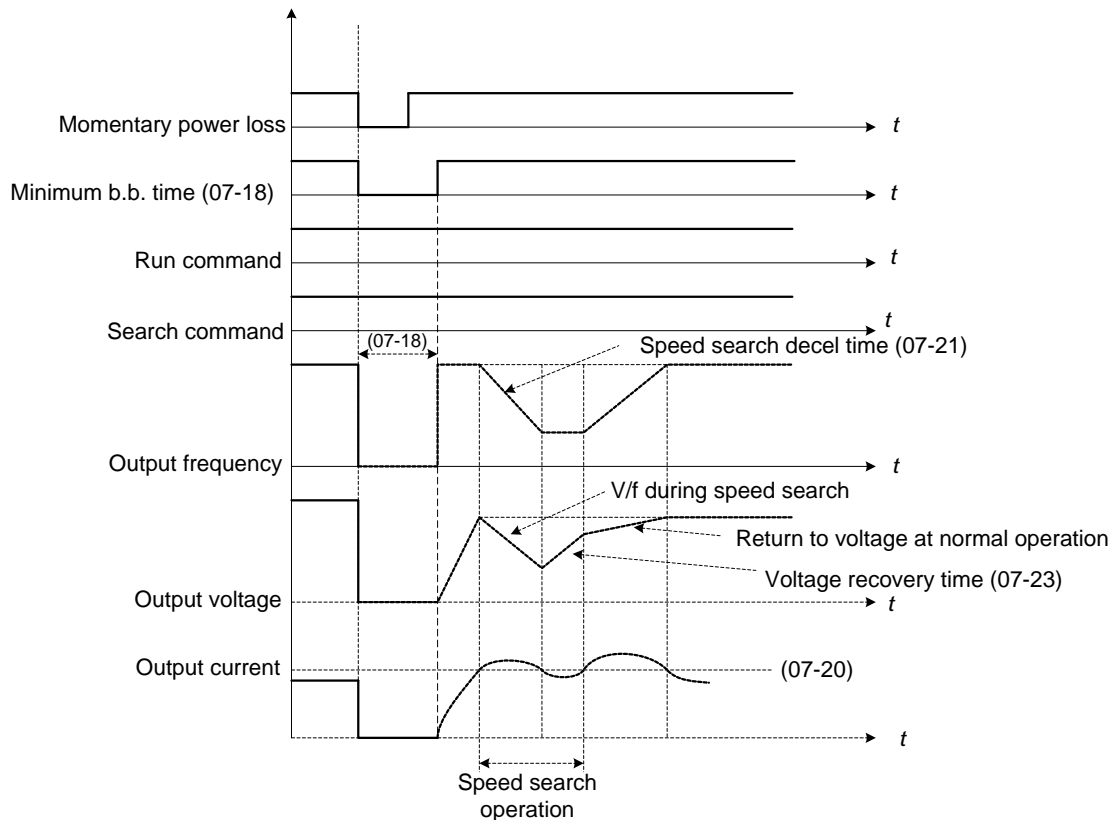

Figure 4.3.56 Speed search in recovery period of momentary power failure

Notes:

- If the minimum base block time (07-18) is longer than the momentary power failure time, the speed search starts operation after the minimum base block time (07-18).
- If the minimum base block time (07-18) is too short, the speed search operation begins immediately after power has been restored.

| 07-29 | Run Command Available During DC Braking |
|-------|--|
| Range | 【0】 : Disable (Run command is disregarded until the DC braking is completed) 【1】 : Enable |

When 07-29 is set to 0 the run command input is ignored until DC braking is completed.

When 07-29 is set to 1 the run command input overrides the DC braking function.

Group 08: Protection Parameters

| | |
|--------------|---|
| 08-00 | Stall Prevention Function |
| Range | 【xxx0b】 : Stall prevention is enabled in acceleration. 【xxx1b】 : Stall prevention is disabled in acceleration. 【xx0xb】 : Stall prevention is enabled in deceleration. 【xx1xb】 : Stall prevention is disabled in deceleration. 【x0xxb】 : Stall prevention is enabled in operation. 【x1xxb】 : Stall prevention is disabled in operation. 【0xxxb】 : Stall prevention in operation decelerates based on deceleration time 1 【1xxxb】 : Stall prevention in operation decelerates based on deceleration time 2 |
| 08-01 | Stall Prevention Level in Acceleration |
| Range | 【30~200】 % |
| 08-02 | Stall Prevention Level in Deceleration |
| Range | 【330~410】 V : 230V 【660~820】 V : 460V |
| 08-03 | Stall Prevention Level in Operation |
| Range | 【30~200】 % |
| 08-21 | Limit of Stall Prevention in Acc over Base Speed |
| Range | 【0~100】 % |
| 08-22 | Stall Prevention Detection Time in Operation |
| Range | 【2~100】 msec |

Stall prevention during acceleration (08-00=xxx0b)

Prevents the inverter from faulting (Overcurrent, Motor overload, Inverter overload) when accelerating with heavy loads.

When the inverter output current reaches the level set in parameter 08-01 minus 15% the acceleration rate starts to decrease. When the inverter output current reaches the level set in parameter 08-01 the motor stops accelerating. Refer to Fig.4.3.57 for more information.

Notes:

- Reduce stall prevention level during acceleration (08-01) in case the motor stalls (when the motor power is smaller than the inverter rating).
- The inverter rated output current should be set to 100%.

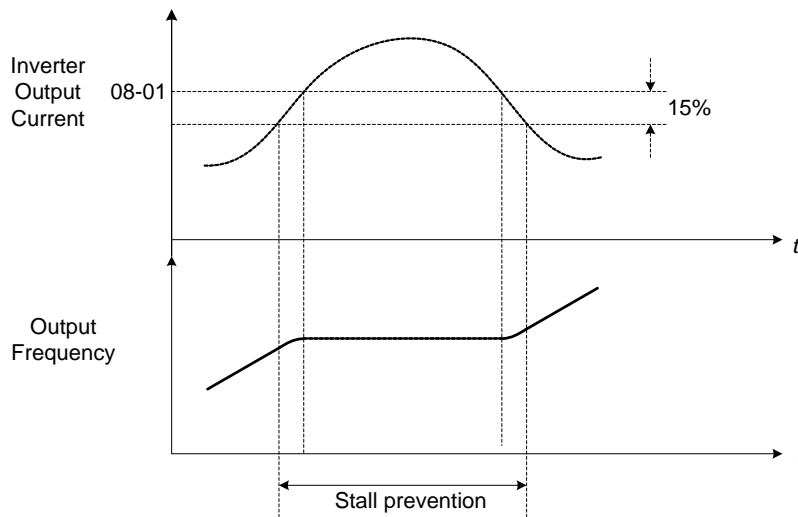

Figure 4.3.57 Stall prevention during acceleration

If the motor is used in the constant power (CH) region, the stall prevention level (08-01) is automatically reduced to prevent the stall.

Stall prevention level during acceleration (Constant horsepower)

$$\text{Stall Prev. Lev. Acceleration (CH)} = \frac{\text{Stall prevention level in acceleration (08-01)} \times \text{Fbase (01-12)}}{\text{Output frequency}}$$

Parameter 08-21 is the stall prevention limit value in Constant Horsepower region. Refer to Fig.4.3.58.

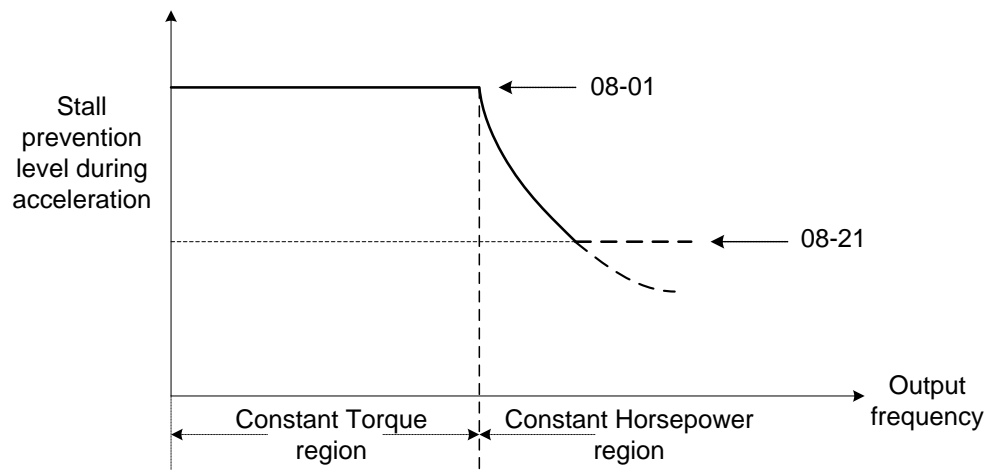

Figure 4.3.58 Stall prevention level and limit in acceleration

Stall prevention selection during deceleration (08-00=xx0xb)

Stall prevention during deceleration automatically increases the deceleration time according based on the DC-bus voltage to prevent over-voltage during deceleration. Refer to Fig.4.3.59 for stall prevention during deceleration

When the DC-bus voltage exceeds the stall prevention level deceleration will stop and the inverter will wait for the DC-bus voltage to fall below the stall prevention level before continuing deceleration. Stall prevention level can be set by 08-02, see Table 4.3.10.

Table 4.3.10 Stall prevention level

| Inverter model | 08-02 default value |
|----------------|---------------------|
| 230V class | 385VDC |
| 460V class | 770VDC |

Note: When using external braking (braking resistor or braking module) disable stall prevention during deceleration (08-00 to xx1xb).

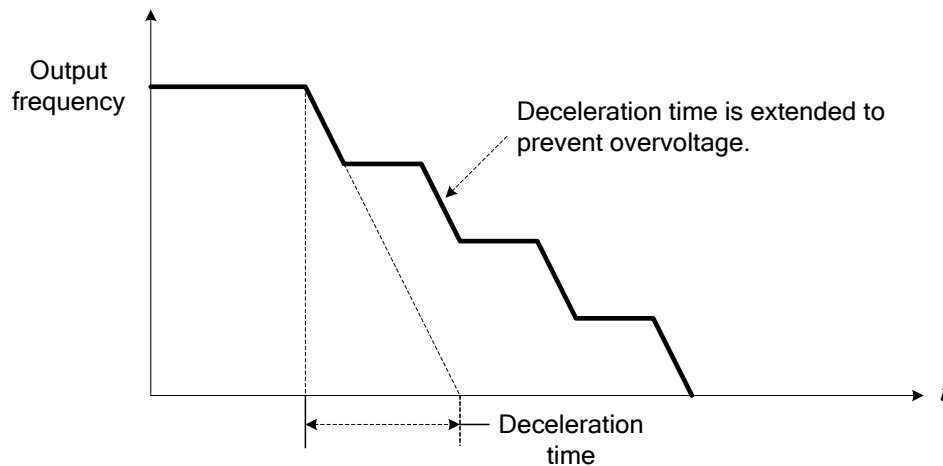

Figure 4.3.59 Stall prevention selection in deceleration

Stall prevention selection during run (08-00=x0xxb)

Stall prevention during run can only be used in V/F or SLV control mode.

This function prevents the motor from stalling by automatically reducing the output frequency during run.

If the inverter output current rises above the level set in parameter 08-03 for the time specified in parameter 08-22, the inverter output frequency is automatically decreased following deceleration time 1 (00-15) or deceleration time 2 (00-17).

When the inverter output current falls below the level set in parameter (08-03) minus 2%, normal operation continues and the output frequency increases to the frequency reference using the acceleration time 1 or acceleration time 2. Refer to the following Fig.4.3.60.

Note: The stall prevention level during run can be set by using multi-function analog input AI2 (04-05=7).

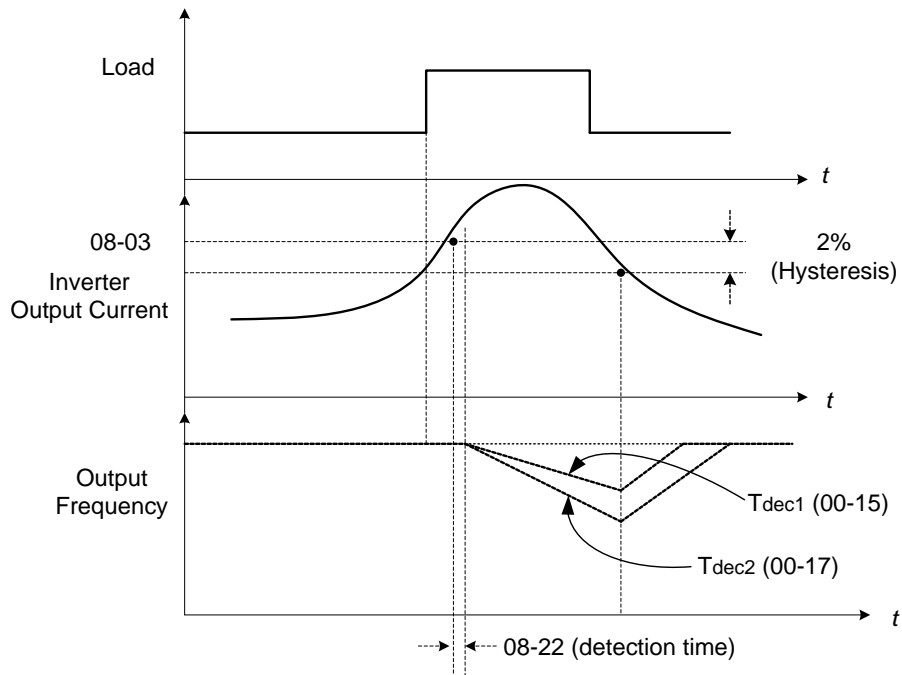

Figure 4.3.60 Stall prevention selection in operation

| 08-05 | Selection for Motor Overload Protection (OL1) |
|-------|--|
| Range | <p> 【xxx0b】 : Motor Overload Protection is disabled. 【xxx1b】 : Motor Overload Protection is enabled. 【xx0xb】 : Cold Start of Motor Overload 【xx1xb】 : Hot Start of Motor Overload 【x0xxb】 : Standard Motor 【x1xxb】 : Special motor 【0xxxb】 : Reserved 【1xxxb】 : Reserved </p> |

The motor overload protection function estimates the motor overload level based on the output current, output frequency, motor characteristics and time. The motor overload trip time depends on the motor rated current when the output frequency is higher than 60Hz.

On inverter power-up the motor overload protection internal thermal accumulation register is automatically reset.

To use the built-in motor overload protection function parameter 02-01 (motor rated current) has to match the motor rated current on the motor nameplate.

Turn off the motor overload protection when using two or more motors connected to the inverter (set 08-05 = xxx0b), and provide external overload protection for each motor (e.g. thermal overload switch).

With cold start enabled (08-05 = xx0xb), motor overload protection occurs in 5 and a half minutes when operating the motor at 150% of the motor rated current at an output frequency greater than 60Hz.

With hot start enabled (08-05 = xx1xb), motor overload protection occurs in 3 and a half minutes when operating

the motor at 150% of the motor rated current at an output frequency greater than 60Hz.

Refer to the following Fig.4.3.61 for an example of motor overload protection standard curve.

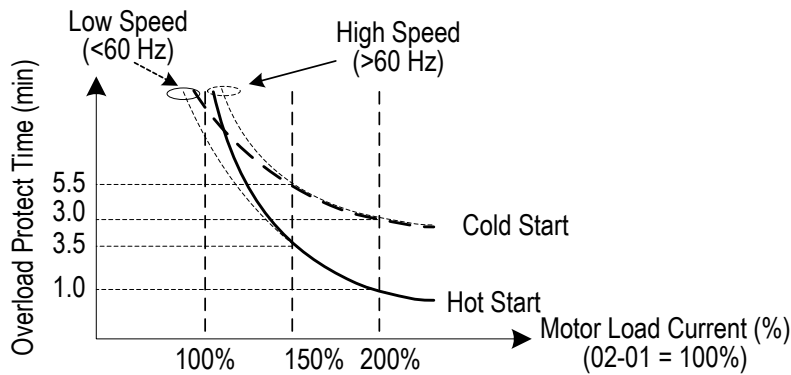

Figure 4.3.61 Motor overload protection curve (example: standard motor)

When using force cooled motors (Special inverter motor), thermal characteristics are independent of the motor speed, set 08-05 = x1xxb.

When 08-05 = x1xxb, overload protection function is based on motor rated current for output frequencies between 6 and 60Hz. If the output frequency is lower than 1Hz, the overload protection function uses 83% of the motor rated current to determine an overload condition.

When 08-05 = x0xxb, overload protection function is based on 70% of the motor rated current for an output frequency of 20Hz. If the output frequency is lower than 1Hz, the overload protection function uses 40% of the motor rated current to determine an overload condition.

Refer to Fig.4.3.62 for motor overload rating at different output frequencies.

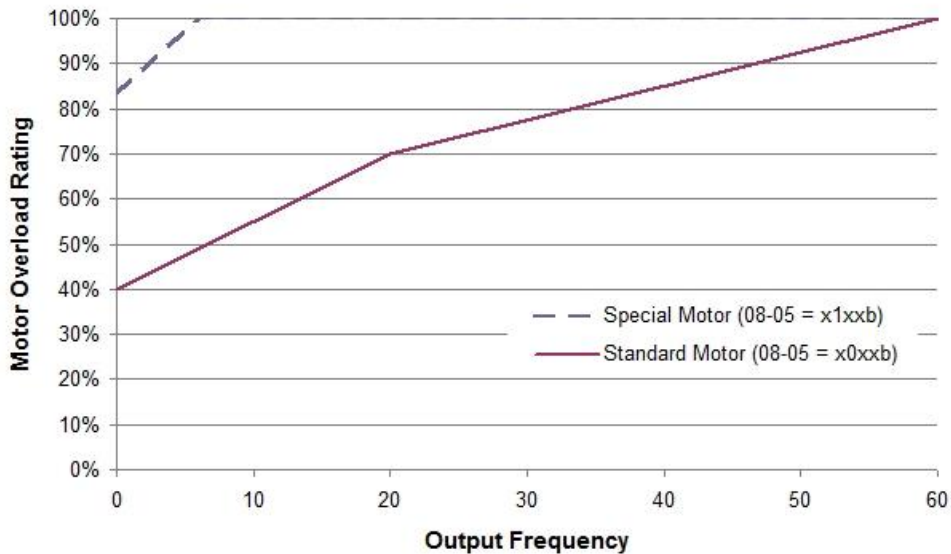

Figure 4.3.62 Motor overload rating at different output frequencies

| | |
|--------------|--|
| 08-06 | Start-up mode of overload protection operation (OL1) |
| Range | 【0】 : Stop Output after Overload Protection 【1】 : Continuous Operation after Overload Protection. |

08-06=0: When the inverter detects a motor overload the inverter output is turned off and the OL1 fault message will flash on the keypad. Press RESET button on the keypad or activate the reset function through the multi-function inputs to reset the OL1 fault.

08-06=1: When the inverter detects a motor overload the inverter will continue running and the OL1 alarm message will flash on the keypad until the motor current falls within the normal operating range.

| | |
|--------------|---|
| 08-08 | Automatic Voltage Regulation (AVR) |
| Range | 【0】 : AVR is enabled 【1】 : AVR is disabled |

Automatic voltage regulation stabilizes the motor voltage independent of fluctuation to the input voltage.

08-08=0: Automatic voltage regulation is active.

08-08=1: Automatic voltage regulation is not active, motor voltage follows the input voltage fluctuation.

| | |
|--------------|---|
| 08-09 | Selection of Input Phase Loss Protection |
| Range | 【0】 : Disable 【1】 : Enable |

08-09=0: Input phase loss detection is disabled.

08-09=1: Input phase loss detection is enabled. Keypad shows "IPL input Phase Loss" (IPL), when an input phase loss is detected the inverter output is turned off and the fault contact is activated.

Note: The input phase loss detection is disabled when the output current is less than 30% of the inverter rated current.

| | |
|--------------|--|
| 08-10 | Selection of Output Phase Loss Protection |
| Range | 【0】 : Disable 【1】 : Enable |

08-10=0: Output phase loss detection is disabled.

08-10=1: Output phase loss detection is enabled. Keypad shows "OPL Output Phase Loss" (OPL), when an output phase loss is detected the inverter output is turned off and the fault contact is activated.

Note: The output phase loss detection is disabled when the output current is less than 10% of the inverter rated current.

| | |
|--------------|--|
| 08-13 | Selection of Over-Torque Detection |
| Range | 【0】 : Over-Torque Detection is Disabled. 【1】 : Start to Detect when Reaching the Set Frequency. 【2】 : Start to Detect when the Operation is Begun. |
| 08-14 | Selection of Over-Torque Operation |
| Range | 【0】 : Deceleration to Stop when Over- Torque is Detected. 【1】 : Display Warning when Over- Torque is Detected. Go on Operation. 【2】 : Coast to Stop when Over Torque is Detected. |
| 08-15 | Level of Over-Torque Detection |
| Range | 【0~300】 % |
| 08-16 | Time of Over-Torque Detection |
| Range | 【0.0~10.0】 Sec |
| 08-17 | Selection of Low-Torque Detection |
| Range | 【0】 : Low-Torque Detection is Disabled. 【1】 : Start to Detect when Reaching the Set Frequency. 【2】 : Start to Detect when the Operation is Begun. |
| 08-18 | Selection of Low-Torque Operation |
| Range | 【0】 : Deceleration to Stop when Low- Torque is Detected. 【1】 : Display Warning when Low- Torque is Detected. Go on Operation. 【2】 : Coast to Stop when Low-Torque is Detected. |
| 08-19 | Level of Low-Torque Detection |
| Range | 【0~300】 % |
| 08-20 | Time of Low-Torque Detection |
| Range | 【0.0~10.0】 Sec |

The over torque detection function monitor the inverter output current or motor torque and can be used to detect increase in inverter current or motor torque (e.g. heavy load).

The low torque detection function monitor the inverter output current or motor torque and can be used to detect a decrease in inverter current or motor torque (e.g. belt break).

The torque detection levels (08-15, 08-19) are based on the inverter rated output current (100% = inverter rated output current) when operating the inverter in V/F control mode and motor output torque (100% = motor rated torque) when operating the inverter in SLV control mode.

Over-torque detection

Parameter 08-13 selects over-torque detection function. An over-torque condition is detected when the output current / torque rises above the level set in parameter 08-15 (Over-torque detection level) for the time specified in parameter 08-06 (Over-torque detection time).

08-13=0: Over-torque detection is disabled.

08-13=1: Over-torque detection is enabled when the output frequency reaches the set frequency.

08-13=2: Over-torque detection is enabled during running.

Parameter 08-14 selects the way the inverter acts when an over-torque condition is detected.

08-14=0: When an over-torque condition is detected the inverter displays and over-torque detection fault and the motor decelerates to a stop.

08-14=1: When an over-torque condition is detected the inverter displays an over-torque detection alarm and continues to run.

08-14=2: When an over-torque condition is detected the inverter displays and over-torque detection fault and the motor coasts to a stop.

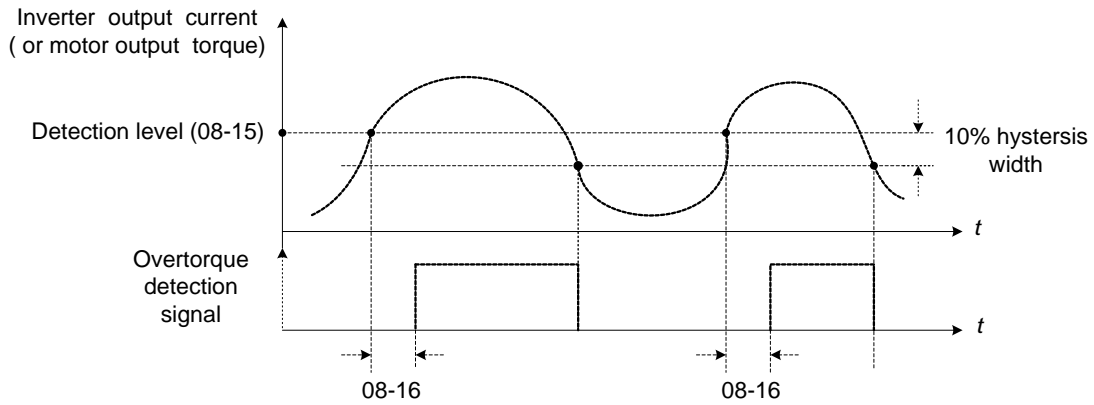

Figure 4.3.63 Over-torque detection operation

Low-torque detection

Parameter 08-18 selects low-torque detection function. An low-torque condition is detected when the output current / torque falls below the level set in parameter 08-19 (low-torque detection level) for the time specified in parameter 08-20 (Low-torque detection time).

08-17=0: Low-torque detection is disabled.

08-17=1: Low-torque detection is enabled when the output frequency reaches the set frequency.

08-17=2: Low-torque detection is enabled during running.

Parameter 08-18 selects the way the inverter acts when an over-torque condition is detected.

08-18=0: When a low-torque condition is detected the inverter displays and low-torque detection fault and the motor decelerates to a stop.

08-18=1: When a low-torque condition is detected the inverter displays a low-torque detection alarm and continues to run.

08-18=2: When a low-torque condition is detected the inverter displays and low-torque detection fault and the motor coasts to a stop.

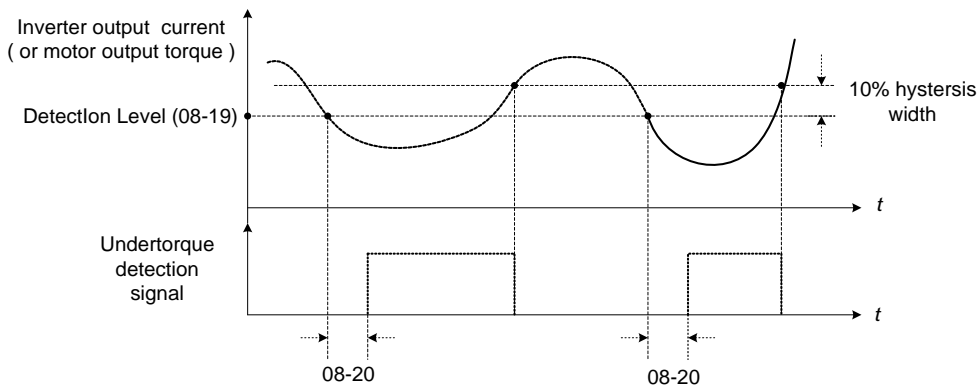

Figure 4.3.64 Low torque detection operation

Over and low torque detection condition can be output to the multi-function digital outputs (R1A-R1C, R2A-R2C, R3A-R3C) by setting parameters 03-11, 03-12 and 03-39 to 12 or 25. Refer to Fig. 4.3.65 for more information.

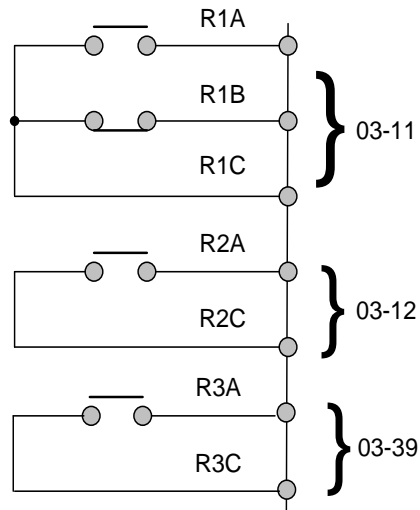

Figure 4.3.65 Over-torque / low torque detection multi-function digital output terminal

| 08-23 | Ground Fault (GF) Selection |
|-------|---|
| Range | 【0】 : Disable 【1】 : Enable |

If the inverter leakage current is greater than 50% of inverter rated current and the ground fault function is enabled (08-23), the keypad will display a "GF Ground Fault" (GF), motor will coast to a stop and fault contact is activated.

| 08-24 | External Fault Operation Selection |
|-------|--|
| Range | 【0】 : Deceleration to Stop 【1】 : Coast to Stop 【2】 : Continuous Operation |

When multi-function digital input terminal is set to 25 (the external fault) and this terminal signal is triggered off, parameter 08-24 (Operation Selection of External Fault) can be selected to stop it. The selection of stop modes is the same as 07-09.

| 08-25 | Detection selection of External Fault |
|-------|---|
| Range | 【0】 : Immediately Detect when the Power is Supplied 【1】 : Start to Detect during Operation |

The reason for the detection of external faults is determined by parameter 08-25.

- When 08-25=0, faults are immediately detected at power up.
- When 08-25=1, faults are detected when the inverter is running.

| | |
|--------------|---|
| 08-30 | Safety Function Operation Selection |
| Range | 【0】 : Deceleration to Stop 【1】 : Coast to Stop |

If multi-function digital input terminal is set to 58 (Safety Function), inverter will stop based parameter 08-30 stop method selection.

| | |
|--------------|--|
| 08-37 | Fan Control Function |
| Range | 【0】 : Start During Operation 【1】 : Immediately Start when Power is supplied 【2】 : Start During High Temperature |
| 08-38 | Delay Time of Fan Off |
| Range | 【0~600】 Sec |

08-37=0: Start at Operation

Fan is on when inverter is running.

When the inverter stops the fan will stop after the delay time specified in 08-38 has expired.

08-37=1: Permanent Start

When the inverter is at power on, fan will start permanently.

08-37=2: Start at High Temperature

If the heatsink temperature is higher than that of internal temperature setting the fan will start immediately.

If the temperature is lower than internal temperature value or the delay time Fan Off (08-38) has expired the fan will be turned off.

Note: Fan control function is disabled for models of 40HP or the above (230V) and 50HP or the above (460V) for IP20 series

| | |
|--------------|---|
| 08-35 | Motor Overheat Operation Selection |
| Range | 【0】 : Disable 【1】 : Deceleration to Stop 【2】 : Coast to Stop |
| 08-36 | PTC Filter Time |
| Range | 【0.00 ~ 5.00】 |
| 08-39 | Delay Time of Motor Overheat Protection |
| Range | 【1 ~ 300】 Sec |

Motor overheat protection can be detected by using a PTC (positive temperature coefficient) thermistor.

PTC Thermistor connects to terminals MT and GND. If the motor is overheating, the keypad displays error code OH4.

08-35=0: Motor overheat fault selection is disabled.

08-35=1, 2: When motor overheats the inverter will trip and the motor will stop running.

Motor overheating is detected when PTC value rises above 1330Ω and the time specified by 08-38 has expired. The keypad will display an "OH4 Motor overheat" and fault output is activated.

When the value of thermistor of PTC is $R_T < 550\Omega$ display (OH4) is reset.

Note: The stop mode of the inverter fault is set by 08-35.

08-35=1: Deceleration to stop when the inverter fault occurs.

08-35=2: Coast to stop when the inverter fault occurs

Notes:

- If no PTC thermistor is connected to MT and GND, the keypad will display an "OH4 Motor overheat."

- The value of the external PTC thermistor is in compliance with British National Standard.

When T_r is 150°C in class F and 180°C in class H,

a. $T_r - 5^\circ\text{C}$: $R_T \leq 550\Omega$

b. $T_r + 5^\circ\text{C}$: $R_T \geq 1330\Omega$

Refer to Fig. 4.3.66 for the connecting between the corresponding temperature of thermistor of PTC and terminals.

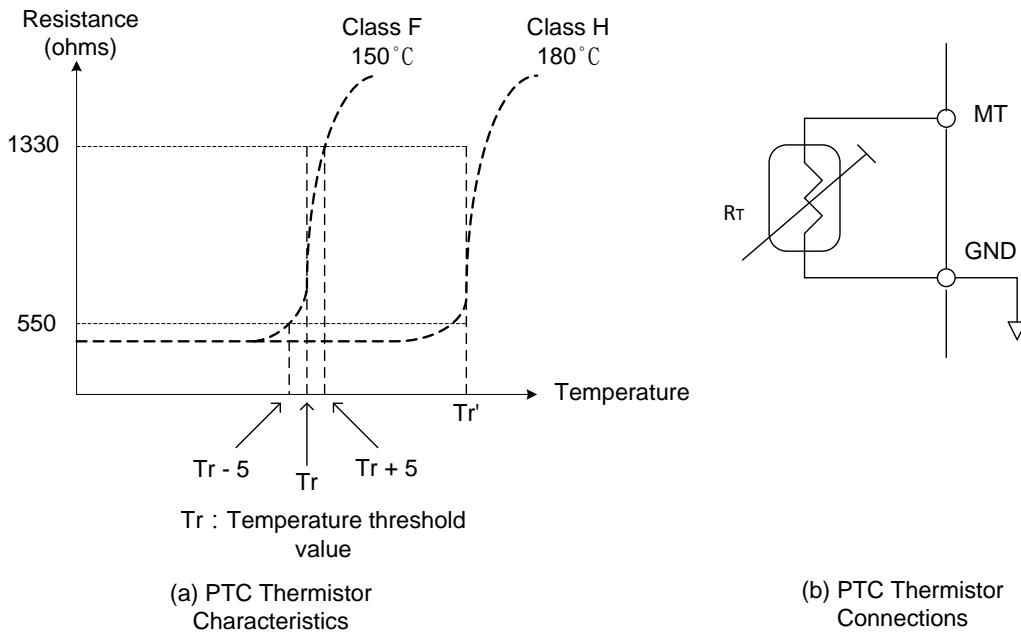

Figure 4.3.66 Protection of motor overheating

| |
|---|
| Group 09: Communication Parameters |
|---|

| | |
|--------------|---|
| 09-00 | INV Communication Station Address |
| Range | 【1~31】 |
| 09-01 | Communication Mode Selection |
| Range | 【0】 : MODBUS 【1】 : BACnet 【2】 : Metasys 【3】 : Multi PUMP 【4】 : PROFIBUS |
| 09-02 | Baud Rate Setting (bps) |
| Range | 【0】 : 1200 【1】 : 2400 【2】 : 4800 【3】 : 9600 【4】 : 19200 【5】 : 38400 |
| 09-03 | Stop Bit Selection |
| Range | 【0】 : 1 Stop Bit 【1】 : 2 Stop Bits |
| 09-04 | Parity Selection |
| Range | 【0】 : No Parity 【1】 : Even Bit 【2】 : Odd Bit |
| 09-06 | Communication Error Detection Time |
| Range | 【0.0~25.5】 Sec |
| 09-07 | Fault Stop Selection |
| Range | 【0】 : Deceleration to Stop Based on Deceleration Time 1 【1】 : Coast to Stop when Communication Fault Occurs. 【2】 : Deceleration to Stop Based on Deceleration Time 2 【3】 : Keep Operating when Communication Fault Occurs. |
| 09-08 | Comm. Fault Tolerance Count |
| Range | 【1~20】 |
| 09-09 | Waiting Time |
| Range | 【5~65】 msec |
| 09-10 | Device Instance Number |
| Range | 1~254 |

The Modbus communication port RJ45 (S+, S-) can be used to monitor, control, program and trouble-shoot the inverter. The built-in RS-485 can support the following communication protocol:

- Modbus communication protocol
- BACnet communication protocol (Refer to section 4.6 for more details)
- Metasys communication protocol (Refer to section 4.7 for more details)
- Pump in Parallel Connection (Refer to parameter group 23 for more details)
- Profibus communication protocol (Refer to section 11.7 Profibus communication option card for more details and this function is required to install Profibus card to be enabled.

Modbus communication can perform the following operations, independent of the frequency command selection (00-05) setting and operation command selection (00-02) setting:

- Monitor inverter signals
- Read and write parameters.
- Reset fault
- Control multi-function inputs

Modbus (RS-485) communication specification:

| Items | Specification |
|--------------------------|---|
| Interface | RS-485 |
| Communication type | Asynchronous (start - stop synchronization) |
| Communication parameters | Baud rate: 1200, 2400, 4800, 9600, 19200 and 38400 bps Data Length: 8 bits (Fixed) Parity: options of none, even and odd bit. For even and odd selection stop bit is fixed at 1 bit. |
| Communication protocol | Modbus RTU / ASCII |
| Number of inverters | Maximum 31 units |

Communication wiring and setup

- (1) Turn off power to the inverter.
- (2) Connect communication lines of the controller to the inverter (RJ45).
- (3) Turn power on.
- (4) Set the required communication parameters (09-00) via the keypad.
- (5) Turn off power to the inverter and wait until keypad is completely off.
- (6) Turn power on
- (7) Start communication between controller and inverter.

Modbus (485) communication architecture

- (1) Modbus communication configuration uses a master controller (PC, PLC), communicating to a maximum of 31 inverters.
- (2) The master controller is directly connected to the inverter via the RS-485 interface. If the master controller has a RS-232, a converter must be installed to convert signals to RS-485 to connect the master controller to the inverter.
- (3) A maximum 31 inverters can be connected to a network, following the Modbus communication standard.

Communication Parameters:

09-00: Inverter station addresses: Range 1-31

09-02: RS-485 communication baud rate setting

- = 0: 1200 bps (bits / second)
- = 1: 2400 bps
- = 2: 4800 bps
- = 3: 9600 bps
- = 4: 19200 bps
- = 5: 38400 bps

09-03: Stop bit selection

- = 0: 1 stop bit
- = 1: 2 stop bits

09-04: Parity selection of RS-485 communication

- = 0: No parity.
- = 1: even parity.
- = 2: odd parity.

09-06: RS-485 communication error detection time

09-07: Stop selection of RS-485 communication failure

- = 0: Deceleration to stop by deceleration time 00-15
- = 1: Coast to stop
- = 2: Deceleration to stop using the deceleration time of 00-26 (emergency stop time)
- = 3: Continue to operate (only shows a warning message, press the stop button to stop operation)

09-08: Comm. fault tolerance count

When the number of communication errors exceeds the value set in parameter 09-08 the inverter will display the comm. Fault alarm.

09-09: Wait time of inverter transmission

Sets the inverter response delay time. This is the time between the controller message and the start of the inverter response message. Refer to Fig. 4.3.67. Set the controller receive time-out to a greater value than the wait time parameter (09-09).

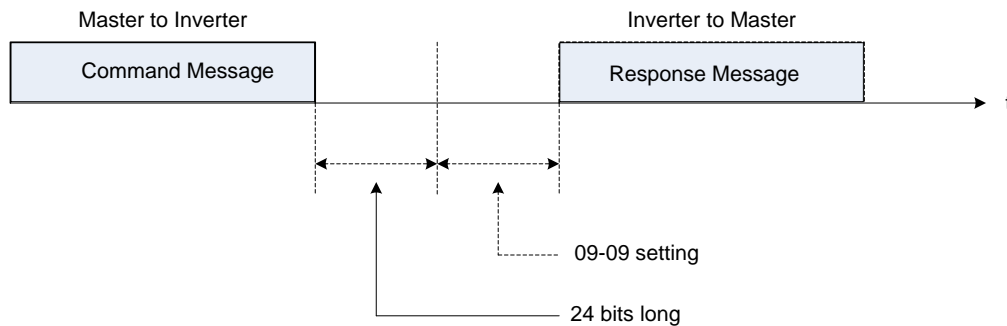

Figure 4.3.67 Communication Message Timing

| |
|---------------------------------|
| Group 10: PID Parameters |
|---------------------------------|

| 10-00 | PID Target Value Source Setting |
|-------|--|
| Range | 【1】 : AI1 Input 【2】 : AI2 Input 【3】 : Reserved 【4】 : 10-02/12-38 Value 【5】 : Reserved 【6】 : Refer to the Setting of 00-05 |

Operation Pressure Setting (23-02) or Target Value of Flow Meters (PUMP or HVAC function selection) can be set as PID's target value only when 10-00=0 and 23-00=1 or 2.

When 10-00=1 or 2, signal source proportional is corresponding to PID target via analog input terminal. For example, 0~10V is corresponding to the target of 0~100% so 2V is equivalent with the target value of 20%.

For normal use of PID, set 10-00 to 4 and set PID target value in parameter 10-02.

When 10-00=4, in addition to the percentage setting of 10-02 (PID target value), it allows PID setting (12-38) in the main screen monitor. The maximum target value is set via parameter 10-33 (PID maximum feedback value), the decimals are set via parameter 10-34 (PID decimal width) and the unit is set via parameter 10-35 (PID unit). For example:

When 10-33 = 999, 10-34 = 1, 10-35 = 3 and 10-02 = 10%, then 12-38 = 9.9 PSI displayed in the main screen monitor. User can also modify the value of 12-38 in the main screen monitor but the maximum value is 99.9 PSI (depending on the setting value of 10-33).

When 10-00=6, active frequency command (main frequency command) is used for the PID setpoint.

| 10-01 | PID Feedback Value Source Setting |
|-------|---|
| Range | 【1】 : AI1 Input 【2】 : AI2 Input 【3】 : Reserved |

Note: Parameter 10-00 and 10-01 cannot be set to the same source. If both parameters are set to the same source the keypad will show a SE05 alarm.

| 10-02 | PID Target Value |
|-------|---|
| Range | 【0.0~100.0】 % |
| 10-03 | PID Control Mode |
| Range | 【xxx0b】 : PID Disable 【xxx1b】 : PID Enable 【xx0xb】 : PID Positive Characteristic 【xx1xb】 : PID Negative Characteristic 【x0xxb】 : PID Error Value of D Control 【x1xxb】 : PID Feedback Value of D Control 【0xxxb】 : PID Output 【1xxxb】 : PID Output +Frequency Command |

When 10-03 is set to xxx 0b, PID will be disabled; if it is set to xxx1b, PID is enabled.

Note:

- LCD keypad will be switched automatically (16-00).
- Main Screen Monitoring will be changed to PID Setting (12-38).
- Sub-Screen Monitoring 1 will be changed to PID Feedback (12-39).
- Sub-Screen Monitoring 2 will be changed to Output Frequency (12-17).

At this time, if the setting is disabled, it will be switched automatically back to frequency command as the main page. When switching to PID setting in the LED keypad, it displays the modes selection of parameter 23-05.

Note: when 23-05=0, set the value in the conditions of 10-33 < 1000 and 10-34=1, or the inverter will display the signal of PID setting error (SE05).

When 10-03 is set to xx0xb, PID output occurs forward; if it is set to xx1xb, PID output occurs reversely. If PID feedback value is lower than the target value when PID output is set to be reverse, the output frequency is lower.

When 10-03 is set to x1xxb, PID control for feedback differential value is enabled; if it is set to x0xxb, basic PID control is enabled. Refer to Fig.4.3.69 and Fig.4.3.70.

When 10-03 is set to 0xxxb, PID output is enabled and it is corresponding to the frequency of 01-02 at 100%.

When 10-03 is set to 1xxxb, PID output and frequency command are enabled. The frequency command percentage (01-02) is added to the PID output during run.

| | |
|--------------|---|
| 10-04 | Feedback Gain |
| Range | 【0.01~10.00】 |
| 10-05 | Proportional Gain (P) |
| Range | 【0.00~10.00】 |
| 10-06 | Integral Time (I) |
| Range | 【0.0~100.0】 Sec |
| 10-07 | Differential Time (D) |
| Range | 【0.00~10.00】 Sec |
| 10-09 | PID Bias |
| Range | 【-100~100】 % |
| 10-10 | PID Primary Delay Time |
| Range | 【0.00~10.00】 % |
| 10-14 | PID Integral Limit |
| Range | 【0.0~100.0】 % |
| 10-23 | PID Limit |
| Range | 【0.00~100.0】 % |
| 10-24 | PID Output Gain |
| Range | 【0.0~25.0】 |
| 10-25 | PID Reversal Output Selection |
| Range | 【0】 : Do not Allow Reversal Output 【1】 : Allow Reversal Output |
| 10-26 | PID Target Acceleration/ Deceleration Time |
| Range | 【0.0~25.5】 Sec |

PID Adjustments

Gain control: The error signal (deviation) between the input command (set value) and the actual control value (feedback). This error signal or deviation is amplified by the proportional gain (P) to control the offset between the set value and the feedback value.

Integral control: The output of this control is the integral of the error signal (difference between set value and feedback value) and is used to minimize the offset signal that is left over from the gain control. When the integral time (I) is increased, the system response becomes slower.

Differential control: This control is the inverse from integral control and tries to estimate the behavior of the error signal by multiplying the error with the differential time. The result is added to the PID input. Differential control slows down the PID controller response and may reduce system oscillation. **Note:** Most applications that PID control (fan and pump) do not require differential control.

Refer to Fig. 4.3.68 for PID control operation

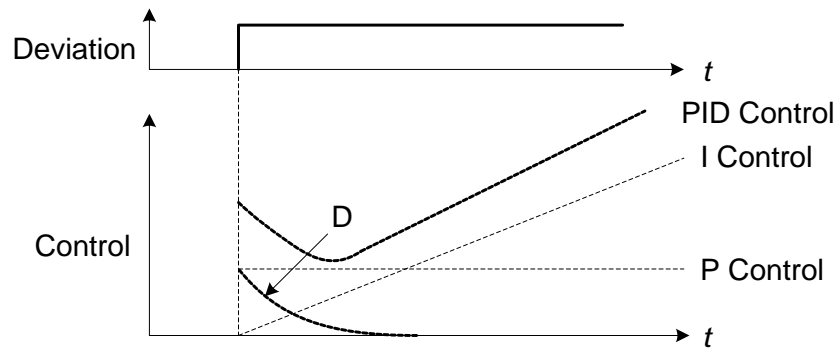

Figure 4.3.68 PID Control

PID Control Type

The inverter offers two types of PID control:

(a) PID control with differential feedback: (10-03 = x1xxb)

Make sure to adjust the PID parameters without causing system instability. Refer to Fig. 4.3.69 for PID control for feedback value differential.

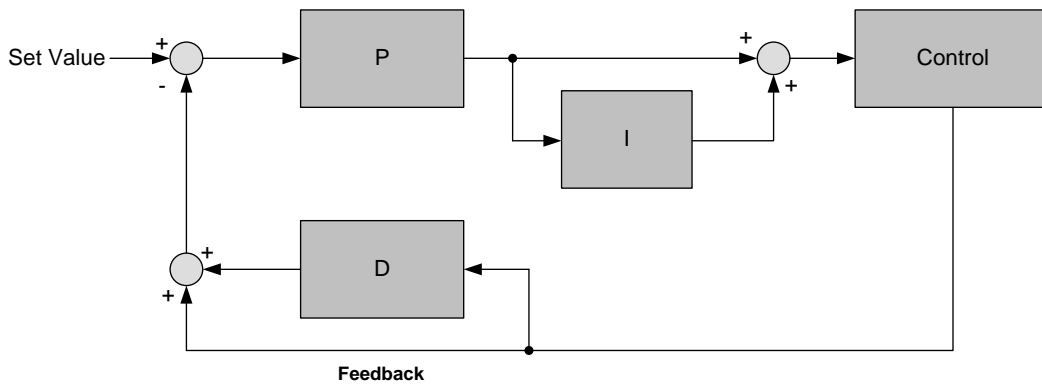

Figure 4.3.69 PID control for feedback differential value

(b) Basic PID control: (10-03 = x0xxb)

This is the basic type of PID control. Refer to the Fig. 4.3.70.

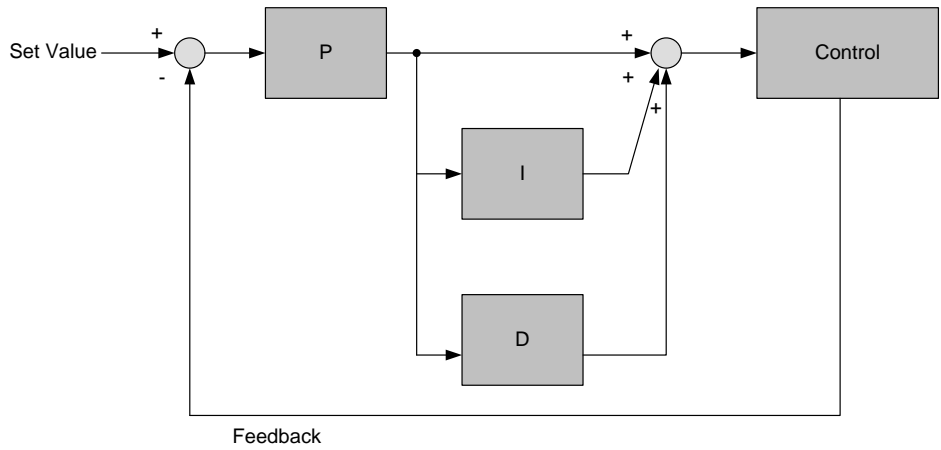

Figure 4.3.70 Basic PID control

PID Setup

Enable PID control by setting parameter 10-03, PID target value (10-00) and PID feedback value (10-01).

To use PID control set frequency command selection 00-05 to 4.

10-00: PID target value

- = 0: keypad Input
- = 1: analog AI1 Input (default)
- = 2: analog AI2 Input
- = 3: Reserved
- = 4: 10-02

10-01: PID feedback value

- = 1: Analog AI1 Input
- = 2: Analog AI2 Input
- = 3: Reserved

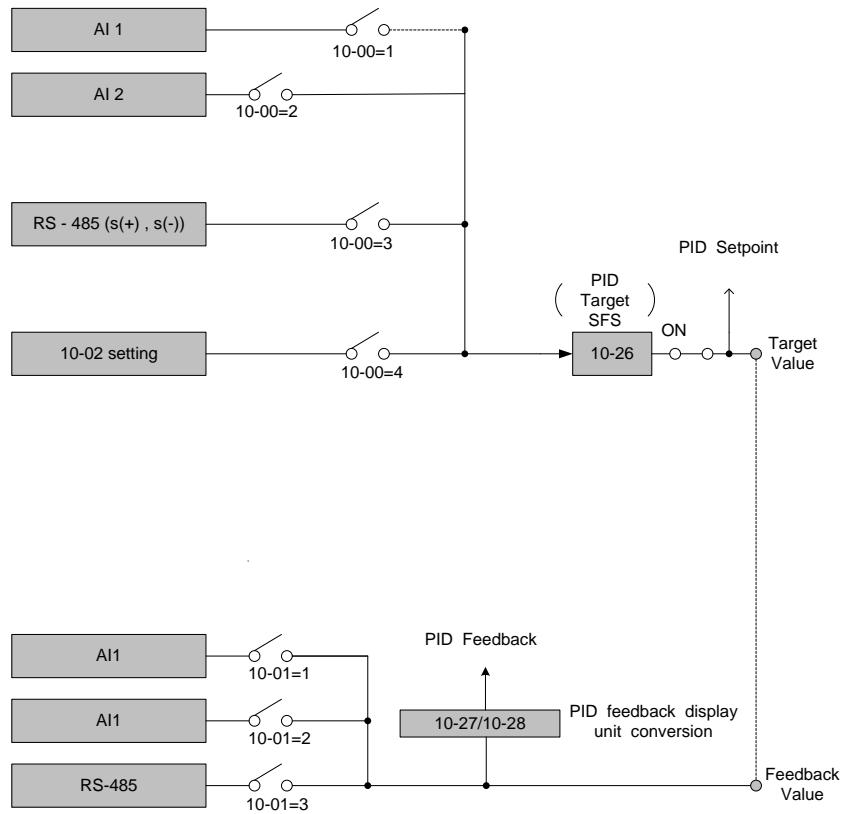

Figure 4.3.71 PID input selection

PID Control Setting

PID control block diagram.

The following figure shows the PID control block diagram.

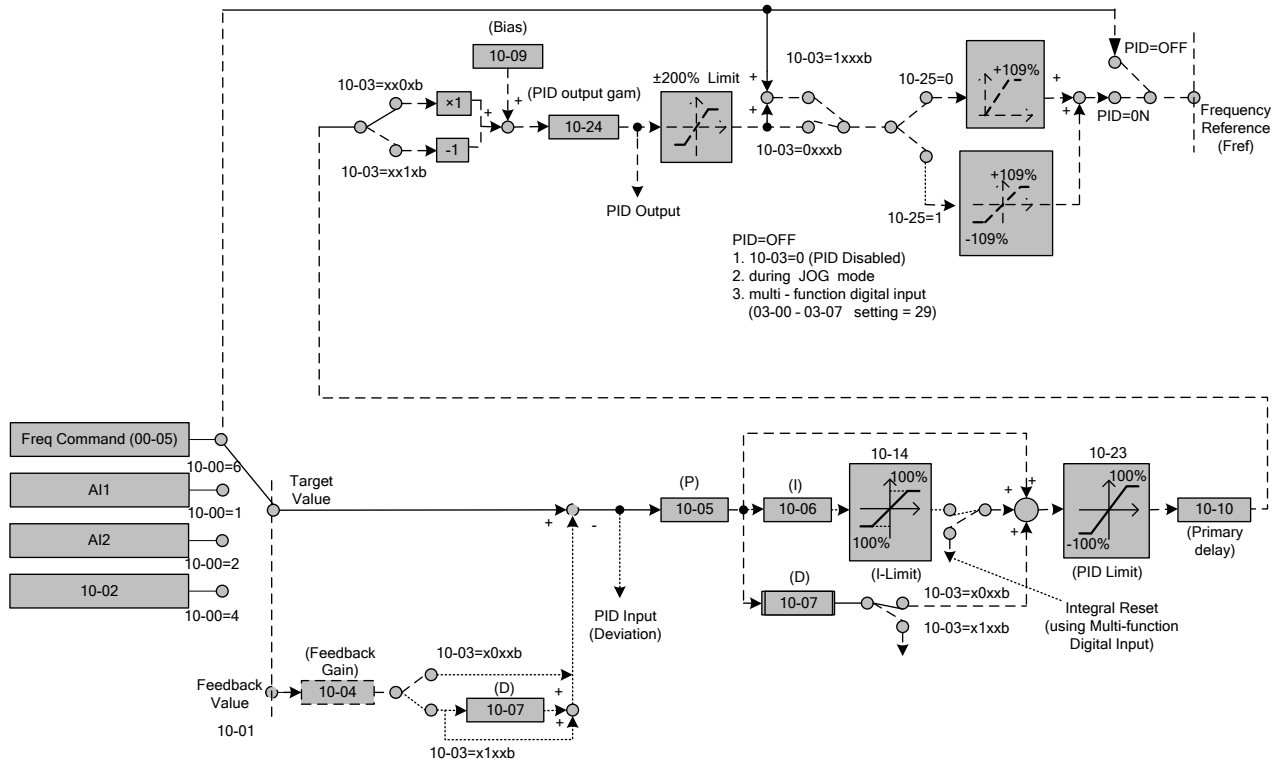

Figure 4.3.72 PID control block diagram

PID Tuning

Use the following procedures to start PID control,

- (1) Enable PID control (set 10-03 to a value greater than "xxx0b").
- (2) Increase the proportional gain (10-05) to 1.0
- (3) Decrease the integral time (10-06) to 10.0
- (4) Increase the differential time (10-07) to 0.0
- (5) Check system response.

The PID control serves to maintain a given process within certain limits whether it is pressure, flow etc. To do this the feedback signal (e.g. pressure transducer) is compared to the set value and the difference becomes the error signal for the PID control.

The PID control then responds by trying to minimize this error. The error is multiplied times the value of the proportional gain set by parameter **10-05**. An increased gain value results in a larger error. However, in any system as the gain is increased there is a point that the system will become unstable (oscillate).

To correct this instability, the response time of the system may be slowed down by increasing the **Integral time** set by parameter **10-06**. However slowing the system down too much may be unsatisfactory for the process.

The end result is that these two parameters in conjunction with the acceleration time (**01-14**) and deceleration (**01-15**) times require to be adjusted to achieve optimum performance for a particular application.

PID output polarity can be selected with parameter 10-03 (setting = xx0xb: PID output forward, setting = xx1xb: PID output reversal). When the PID output is set for reverse operation the output frequency decreased when the PID target value increases.

PID feedback value can be adjusted using parameter 10-04 (PID feedback gain) as well as with the analog input gain and bias for terminal AI1 or AI2.

10-14: PID integral limit: Used to limit the integral output to prevent motor stall or damage to the system in case of a rapid change in the feedback signal. Reduce the value of 10-14 to increase the inverter response.

10-23: PID limit: Used to limit the output of the PID control. Maximum output frequency is 100%.

10-10: Primary delay time: Low pass filter situated after the PID limit block that can be used to prevent PID output resonance. Increase the time constant to a value greater than the resonance frequency cycle and reduce time constant to increase the inverter response.

10-09: PID bias: Used to adjust the offset of the PID control. The offset value is added to the frequency reference as compensation. Use parameter **10-24** (PID output gain) to control the amount of compensation.

In case the PID control output value goes negative, parameter 10-25 (PID reversal output selection) can be used to reverse the motor direction.

Note: The PID output remains at zero when reverse operation is disabled.

10-26: PID target SFS: Sets the PID target value acceleration and deceleration ramp time. The PID target SFS can be disabled by setting the multi-function digital inputs 03-00 ~ 03-05 to 36 (PID target SFS is off). Reduce the acceleration / deceleration time in case load resonance or system instability is encountered.

PID Fine Tuning

All PID control parameters are related to each other and require to be adjusted to the appropriate values. Therefore, the procedure achieving the minimum steady-state is shown as following:

- (1) Increase or decrease the proportion (P) gain until the system is stable using the smallest possible control change.
- (2) The integral (I) reduces the system stability which is similar to increasing the gain. Adjust the integral time so that the highest possible proportional gain value can be used without affecting the system stability. An increase in the integral time reduces system response.
- (3) Adjust the differential time if necessary to reduce overshoot on startup. The acceleration / deceleration time can also be used for the same purpose.

Fine-tuning PID control parameters:

- (1) Reduce overshoot

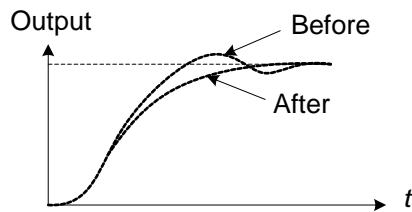

In case overshoot occurs, reduce the derivative time (D) and increase the integral time (I).

- (2) Stabilize PID control

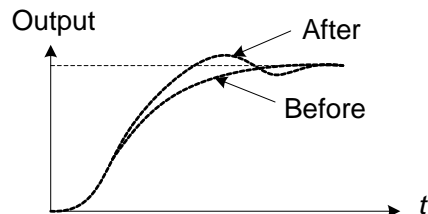

To quickly stabilize the PID control, reduce the integral time (I) and increase the differential time (D) in case overshoot occurs.

- (3) Reduce long-period oscillation

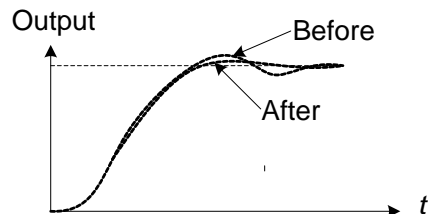

Adjust the integral time (I) in case of long-periodical system oscillation.

- (4) Reduce short-period oscillation

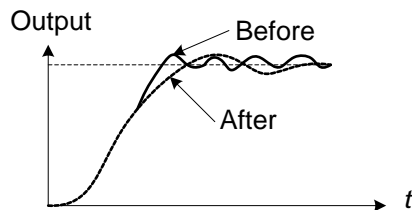

Adjusting the differential time (D) and proportional (P) gain when experiencing short-periodical oscillation.

| | |
|--------------|--|
| 10-11 | PID Feedback Loss Detection Selection |
| Range | 【0】 : Disable 【1】 : Warning 【2】 : Fault |
| 10-12 | PID Feedback Loss Detection Level |
| Range | 【0~100】 % |
| 10-13 | PID Feedback Loss Detection Time |
| Range | 【0.0~10.0】 Sec |

The PID control function provides closed-loop system control. In case PID feedback is lost, the inverter output frequency may increase to the maximum output frequency.

It is recommended to enable to the PID feedback loss when the PID function is used.

PID feedback loss detection

10-11=0: Disable

10-11=1: Warning

A feedback loss condition is detected when the PID feedback value falls below the value set in parameter 10-12 (PID feedback loss detection level) for the time set in parameter 10-13 (PID feedback loss detection time). PID feedback loss warning message "Pb" will be displayed on the keypad and the inverter will continue to operate.

10-11=2: Fault

A feedback loss condition is detected when the PID feedback value falls below the value set in parameter 10-12 (PID feedback loss detection level) for the time set in parameter 10-13 (PID feedback loss detection time). PID feedback loss fault message "Fb" will be displayed on the keypad, the inverter stops and the fault contact is activated.

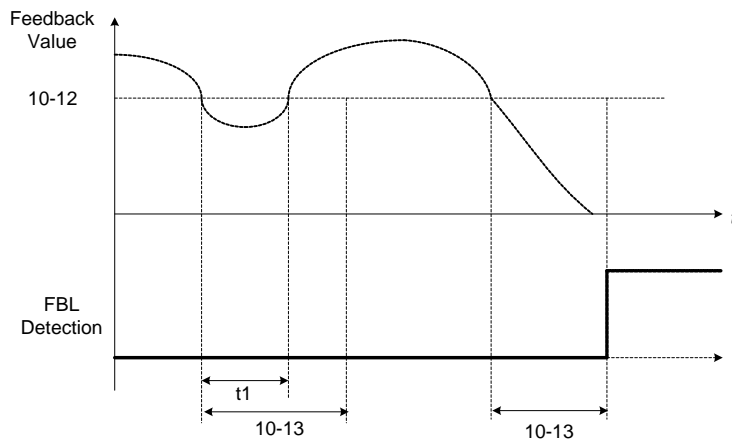

Figure 4.3.73 PID feedback loss detection

| | |
|--------------|---|
| 10-17 | Start Frequency of PID Sleep |
| Range | 【0.00~180.00】 Hz |
| 10-18 | Delay Time of PID Sleep |
| Range | 【0.0~255.5】 Sec |
| 10-19 | Frequency of PID Waking up |
| Range | 【0.00~180.00】 Hz |
| 10-20 | Delay Time of PID Waking up |
| Range | 【0.0~255.5】 Sec |
| 10-29 | PID Sleep Selection |
| Range | 【0】 : Disable 【1】 : Enable 【2】 : Set by DI |
| 10-40 | Compensation Frequency of PID Sleep Selection |
| Range | 【0】 : Disable 【1】 : Enable |

The PID Sleep function is used to stop the inverter when the PID output falls below the PID sleep level (10-17) for the time specified in the PID sleep delay time parameter (10-18).

The inverter wakes up from a sleep condition when the PID output (Reference frequency) rises above the PID wake-up frequency (10-19) for the time specified in the PID wake-up delay time (10-20).

Use parameter 10-29 to enable / disable PID sleep function.

10-29 =0: PID Sleep function is disabled.

10-29 =1: PID sleep operation is based on parameters of 10-17 and 10-18.

10-29 =2: PID sleep mode is enabled by multi-function digital input

Refer to Fig.4.3.74 (a) and (b) for PID sleep / wakeup operation.

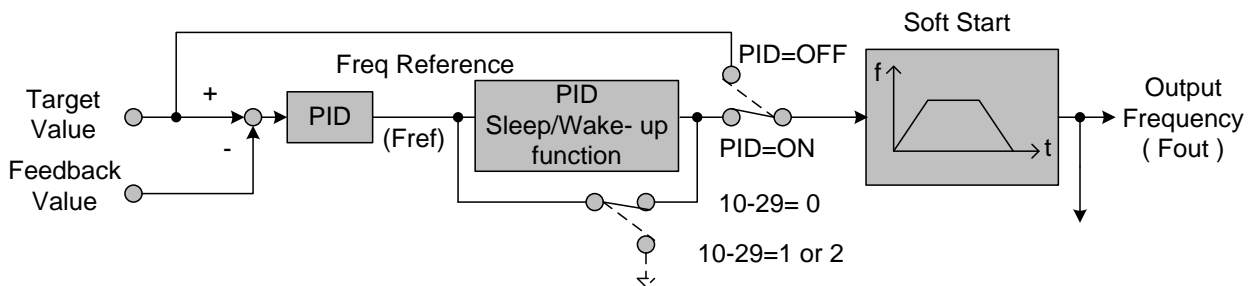

Figure 4.3.74: (a) PID control block diagram

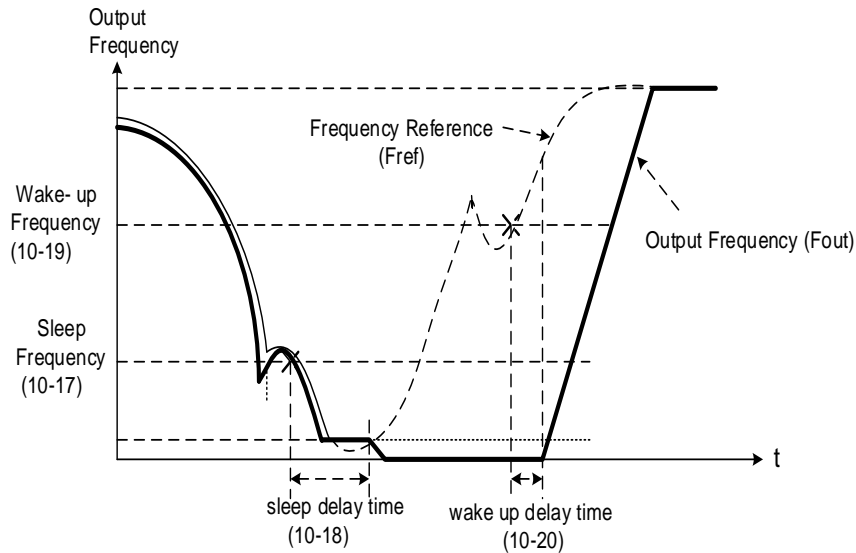

Figure 4.3.74: (b) Timing diagram of PID sleep / wakeup

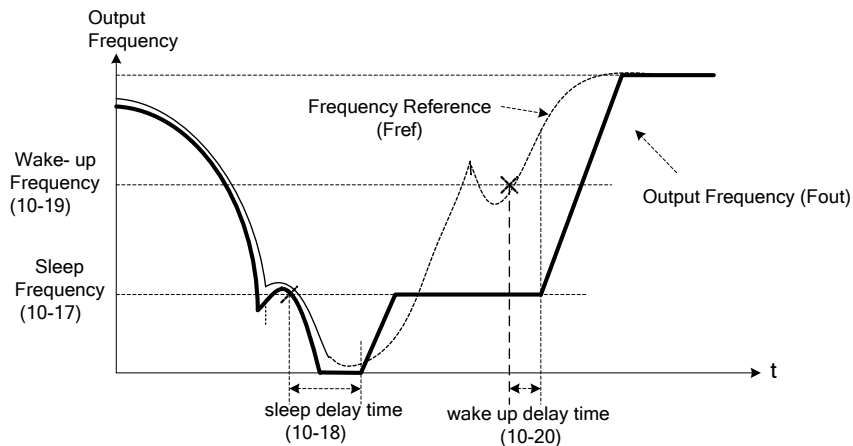

Figure 4.3.74: (c) Timing diagram of PID sleep frequency/ wakeup

When PID enters sleep mode the output frequency will directly go to 0Hz.

Notes:

- Refer to Fig. 4.3.74: (b) for parameter 10-40=0. The PID sleep timer is enabled when the output frequency (Fout) falls below the PID sleep frequency (10-17). When the sleep timer reaches the set PID sleep delay time (10-18) the inverter will decelerate to a stop and enter the sleep mode.
- Refer to Fig.4.3.74: (c) for parameter 10-40=1. The PID sleep timer is enabled when the output frequency (Fout) falls below the PID sleep frequency (10-17). When the sleep timer reaches the set PID sleep delay time (10-18), the motor will gradually run to PID sleep frequency set by 10-17. (Only applies when using a fixed frequency.)
- While sleep mode is active and the motor has stopped, the internal PID control is still in operating. When the reference frequency increases and exceeds the wakeup frequency parameter 10-19 for the time specified in the wakeup delay time parameter 10-20, the inverter will restart and the output frequency will ramp up to the reference frequency.
- Parameter 10-00 and 10-01 cannot be set to the same source. If both parameters are set to the same source the keypad will show a SE05 alarm.

| | |
|--------------|----------------------------------|
| 10-27 | PID Feedback Display Bias |
| Range | 【-99.99~99.99】 |
| 10-28 | PID Feedback Display Gain |
| Range | 【0.00~100.00】 |

PID Feedback Display Scaling

The PID feedback signal can be scaled to represent actual engineering units. Use parameter 10-28 to set the feedback signal gain for the feedback signal range maximum and parameter 10-27 to the feedback signal minimum.

Example:

Feedback signal is a pressure transducer (4-20mA) with a range of 0 – 200 PSI
 4mA = 0 PSI, 20mA = 200 PSI.

Set parameter 10-27 to 0.0 minimum of transducer range (0%).
 Set parameter 10-28 to 2.0 maximum of transducer range (100%).

Refer to the Fig.4.3.75 for displaying the unit conversion.

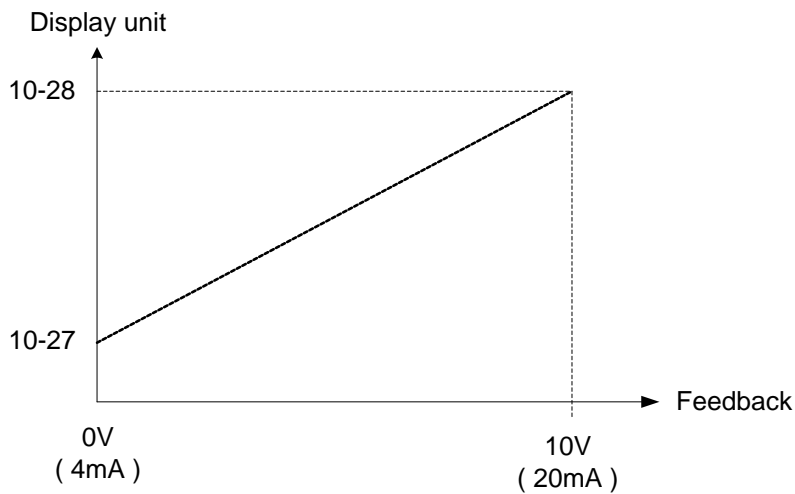

Figure 4.3.75 Feedback signal scaling

| | |
|--------------|----------------------------------|
| 10-30 | Upper Limit of PID Target |
| Range | 【0 ~ 100】 % |
| 10-31 | Lower Limit of PID Target |
| Range | 【0 ~ 100】 % |

PID target value will be limited to the upper and lower limit range of PID target.

| | |
|--------------|---|
| 10-32 | PID Switching Function |
| Range | 【0】 : PID1 【1】 : PID2 【2】 : Switch to PID2 by DI 【3】 : Switch to PID2 by RTC |

10-32=0: PID 1 function is enabled.

PID target value is set by 10-02 and proportional gain, integral time and differential time are set by 10-05, 10-06 and 10-07.

10-32=1: PID 2 function is enabled.

PID target value is set by 10-02 and proportional gain, integral time and differential time are set by 10-36, 10-37 and 10-38.

10-32=2: Set by Digital Input

If the digital input terminal is enabled (digital multi-function terminal is set to 54), PID1 will switch to PID2.

10-32=3: Set by RTC

When RTC timer is enabled, PID1 will switch to PID2.

| | |
|--------------|-----------------------------------|
| 10-33 | PID Maximum Feedback Value |
| Range | 【1~10000】 |

Function of PID maximum feedback value is the 100% corresponding value of 10-02.

| | |
|--------------|--------------------|
| 10-34 | PID Scaling |
| Range | 【0~4】 |

Function of PID decimal width enables the user to set the decimal point.

For example, if it is set to 1, the keypad displays the first decimal place XXX.X. If it is set to 2, the keypad displays the second decimal place XX.XX.

| | |
|--------------|-----------------|
| 10-35 | PID Unit |
| Range | 【0~23】 |

PID unit enables the user to select the unit for PID target value.

When 10-35=0, parameter of 12-38 will be used by the unit of %.

| | |
|--------------|-----------------------------------|
| 10-36 | PID2 Proportional Gain (P) |
| Range | 【0.00~10.00】 |
| 10-37 | PID2 Integral Time (I) |
| Range | 【0.0~100.0】 Sec |
| 10-38 | PID2 Differential Time (D) |
| Range | 【0.00~10.00】 Sec |

Refer to the PID function for more details of PID2 description.

| | |
|--------------|---|
| 10-39 | Force Frequency During PID Feedback Loss |
| Range | 【0~400】 Hz |

When the warning of PID feedback disconnection occurs, frequency command output depends on the parameter 10-39. When the disconnection warning is removed, PID control restores.

Group 11: Auxiliary Parameters

| 11-00 | Direction Lock Selection |
|-------|---|
| Range | 【0】 : Allow Forward and Reverse Rotation 【1】 : Only Allow Forward Rotation 【2】 : Only Allow Reverse Rotation |

If motor operation direction is set to 1 or 2, the motor can only operate in that specific direction. Run command in opposite direction is disabled.

Forward or reverse commands can be issued via the control terminals or keypad when 11-00 is set to 0.

Note: The reverse rotation selection can be used in fan and pump application where reverse rotation is prohibited.

| 11-01 | Carrier Frequency |
|-------|--|
| Range | 【0】 : Carrier Output Frequency Tuning 【1】 : 1.5 KHz 【2~16】 2~16 KHz |

Notes:

- (1) Value 1 to 16 represents KHz.
- (2) When 11-01=0, variable carrier frequency is used see parameter 11-30~11-32.
- (3) For SLV mode, the minimum value of 11-01 is 4 kHz.
- (4) Setting range is determined by the inverter rating (13-00).
- (5) Refer to section 3 inverter derating based on carrier frequency.
- (6) A low carrier frequency increases motor noise but reduces motor losses and temperature.
- (7) A low carrier frequency decreases RFI, EMI interference and motor leakage current.

Refer to the carrier frequency Table 4.3.11.

Table 4.3.11 Carrier frequency settings

| Carrier frequency (11-01=1 to 16)) | 1.5KHz--6K--10K--16KHz | | |
|------------------------------------|------------------------|-------|---------------------|
| Motor noise | High | ----- | low |
| Output current waveform | Non-sinusoidal | ----- | sinusoidal (better) |
| Noise interference | Low | ----- | high |
| Leakage current | Low | ----- | high |

If wire length between the inverter and the motor is too long, the high-frequency leakage current will cause an increase in inverter output current, which might affect peripheral devices. Adjust the carrier frequency to avoid this as shown in Table 4.3.12.

Table 4.3.12 Wire length and carrier frequency

| Wire length | < 30 Meter (98ft) | up to 50 Meter (164 ft) | up to 100 Meter (328ft) | > 100 Meter > 328ft |
|---------------------------------|--------------------------------|--------------------------------|-------------------------------|------------------------------|
| Carrier frequency (11-01 value) | Max. value 16KHz (11-01=14KHz) | Max. value 10KHz (11-01=10KHz) | Maxi. value 5KHz (11-01=5KHz) | Max. value 2KHz (11-01=2KHz) |

Notes:

- Reduce the carrier frequency if the torque does not match the speed.
- In V/F control mode, the carrier frequency is determined by parameters 11-30 (Carrier frequency max. limit), 11-31 (Carrier frequency lower limit) and 11-32 (Carrier frequency proportional gain).

| | |
|--------------|---|
| 11-02 | Soft PWM Function Selection |
| Range | 【0】 : Disable 【1】 : Enable |

11-02=0: Soft-PWM control disabled.

11-02=1: Soft-PWM control enabled. Soft-PWM control can improve audible noise produced by the motor. Soft-PWM also limits RFI noise to a minimum level. The default setting of Soft-PWM control is disabled. When Soft-PWM is enabled, the maximum carrier frequency is limited to 8 kHz.

| | |
|--------------|---|
| 11-03 | Automatic Carrier Lowering Selection |
| Range | 【0】 : Disable 【1】 : Enable |

11-03=0: Automatic carrier frequency reduction during an overheat condition is disabled.

11-03=1: Carrier frequency is automatically lowered in case the inverter heatsink overheats and returns to carrier frequency set in parameter 11-01 when the inverter temperature returns to normal. See section 3.5 for more information.

| | |
|--------------|--|
| 11-04 | S-curve Time Setting at the Start of Acceleration |
| 11-05 | S-curve Time Setting at the End of Acceleration |
| 11-06 | S-curve Time Setting at the Start of Deceleration |
| 11-07 | S-curve Time Setting at the End of Deceleration |
| Range | 【0.00~2.50】 Sec |

The S curve function for acceleration / deceleration is used to reduce mechanical impact caused by the load during momentary starting and stopping of the inverter. To use the S curve function set the time for acceleration start point (11-04), acceleration end point (11-05), deceleration start point (11-06) and deceleration end point (11-07). Refer to Fig.4.3.76 for more information.

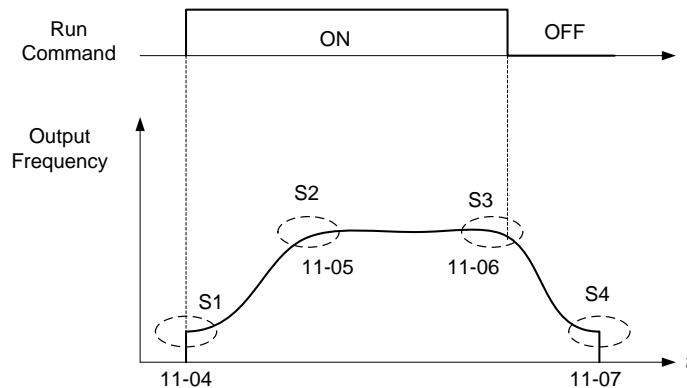

Figure 4.3.76 S curve characteristic

Total acceleration and deceleration time when the S curve is used:

$$\text{Accelerating time} = \text{Accelerating time 1 (or 2)} + \frac{(11-04) + (11-05)}{2}$$

$$\text{Deceleration time} = \text{Deceleration time 1 (or 2)} + \frac{(11-06) + (11-07)}{2}$$

| | |
|-------|----------------------|
| 11-08 | Jump Frequency 1 |
| 11-09 | Jump Frequency 2 |
| 11-10 | Jump Frequency 3 |
| Range | 【0.0~400.0】 Hz |
| 11-11 | Jump Frequency Width |
| Range | 【0.0~25.5】 Hz |

These parameters allow “jumping over” of certain frequencies that can cause unstable operation due to resonance within certain applications.

Note: Prohibit any operation within the jump frequency range. During acceleration and deceleration the frequency is continuous without skipping the jump frequency.

To enable jump frequency 1 – 3 (11-08 – 11-10) set the frequency to a value greater than 0.0 Hz.

Use the jump frequency width (11-11) to create a jump frequency range. Refer to Fig.4.3.77.

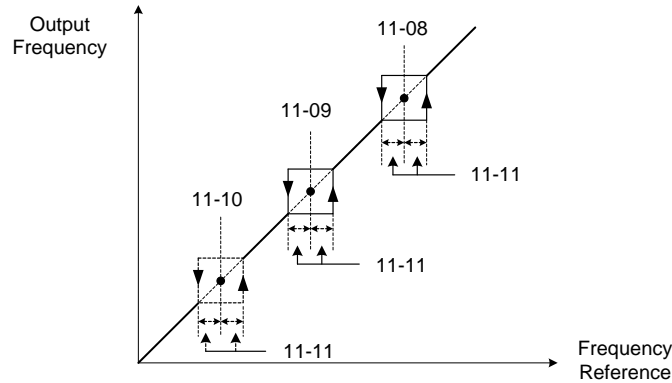

Figure 4.3.77 Jump frequency operation

Jump frequency via Analog Input.

Set parameter 04-05 (AI2 function selection) to 9 (frequency jump setting 4) to control the jump frequency via analog input AI2. Refer to Fig. 4.3.38.

Note: When jump frequency overlap the sum of the overlapped jump frequencies will be used as the jump frequency range. Refer to Fig.4.3.78.

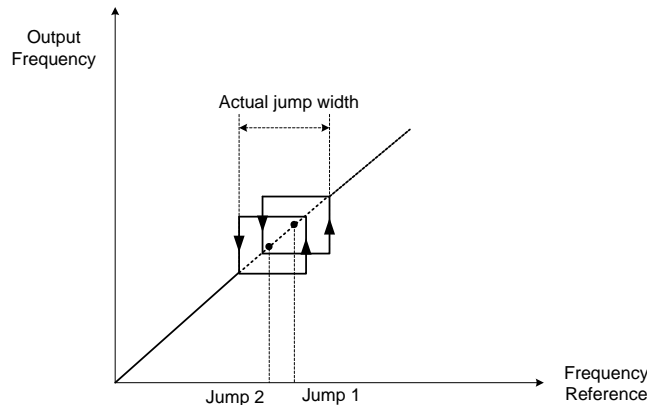

Figure 4.3.78 Jump frequency overlap

| | |
|--------------|---------------------------|
| 11-13 | Keypad Return Time |
| Range | 【0~120】 Sec |

If the keypad is not pressed within the time set by 11-13, it will automatically return to the mode screen.

When it is set to 0, function of automatic return key is off. Press the return key to return to the previous directory.

| | |
|--------------|---------------------------------------|
| 11-12 | Manual Energy Saving Gain |
| Range | 【0~100】 % |
| 11-18 | Manual Energy Saving Frequency |
| Range | 【0.00~400.00】 Hz |

Manual energy savings reduces the output voltage to save energy.

To enable manual energy savings set one of the multi-function digital input (03-00 to 03-05) to 20 and activate the input or use parameter 11-18 to set the manual energy savings activation frequency.

When the output frequency rises above the value set in parameter 11-18 manual energy savings function is enabled. Setting parameter 11-18 manual energy savings frequency to 0.0 Hz disables the manual energy savings frequency activation function. Refer to figure 4.3.88 for more information.

Note: Only use manual energy savings functions in combination with variable torque loads (e.g. Fans, pumps).

Manual energy saving gain (11-12) determines the output voltage of the inverter when manual energy savings is enabled. Output voltage is percentage gain times the V/F voltage.

Manual energy saving control uses the voltage recovery time (07-23) to change the output voltage

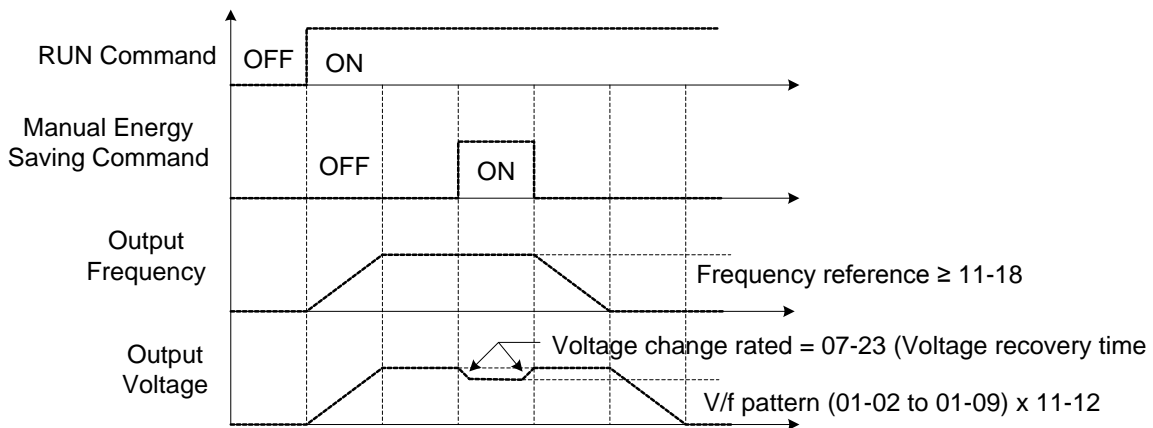

Figure 4.3.79 Manual energy saving operation

| | |
|--------------|---|
| 11-19 | Automatic Energy Saving Function |
| Range | 【0】 : Automatic Energy Saving is Disabled. 【1】 : Automatic Energy Saving is Enabled. |
| 11-20 | Filter Time of Automatic Energy Saving |
| Range | 【0~200】 msec |
| 11-21 | Voltage Upper Limit of Energy Saving Tuning |
| Range | 【0~100】 % |
| 11-22 | Adjustment Time of Automatic Energy Saving |
| Range | 【0~5000】 msec |
| 11-23 | Detection Level of Automatic Energy Saving |
| Range | 【0~100】 % |
| 11-24 | Coefficient of Automatic Energy Saving |
| Range | 【0.00~655.35】 |

In the V/F control mode the automatic energy saving (AES) function automatically adjusts the output voltage and reduces the output current of the inverter to optimize energy savings based on the load.

The output power changes proportional to the motor load. Energy savings is minimal when the load exceeds 70% of the output power and savings become greater when the load decreases.

The parameter of automatic energy saving function has been set at the factory before shipment. In general, it is no need to adjust. If the motor characteristic has significant difference from the TECO standard, please adjust the following parameters:

Enable Automatic Energy Savings Function

- (1) To enable automatic energy saving function set 11-19 to 1.
- (2) Filter time of automatic energy saving (11-20)
- (3) Commissioning parameter of energy saving (11-21 to 11-22)

In AES mode, the optimum voltage value is calculated based on the load power requirement but is also affected by motor temperature and motor characteristic.

In certain applications the optimum AES voltage needs to be adjusted in order to achieve optimum energy savings. Use the following AES parameters for manual adjustment:

11-21: Voltage limit value of AES commissioning operation

Sets the voltage upper limit during automatic energy saving. 100% corresponds to the settings of parameter 01-03 (Maximum Output Voltage) depending on the inverter class used. Refer to the Fig.4.3.80.

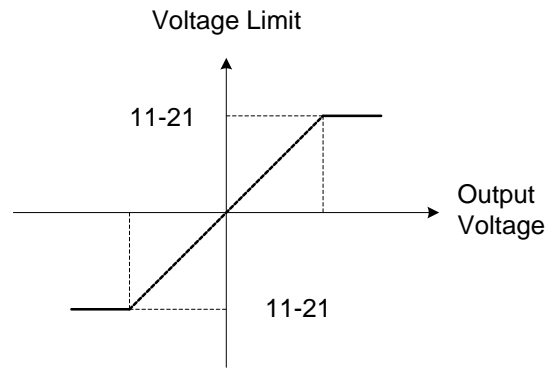

Figure 4.3.80 Voltage limit value of commissioning operation

11-22: Adjustment time of automatic energy saving

Set sample time constant for measuring output power.

Reduce the value of 11-22 to increase response when the load changes.

Note: If the value of 11-22 is too low and the load is reduced the motor may become unstable.

11-23: Detection level of automatic energy saving

Set the automatic energy saving output power detection level.

11-24: Coefficient of automatic energy saving

The coefficient is used to tune the automatic energy saving. Adjust the coefficient while running the inverter on light load while monitoring the output power. A lower setting means lower output voltage.

Notes:

- If the coefficient is set to low the motor may stall.
- Coefficient default value is based on the inverter rating. Set parameter 13-00. If the motor power does not match the inverter rating.

| | |
|--------------|---|
| 11-29 | Auto De-rating Selection |
| Range | 【0】 : Disable 【1】 : Enable |

The automatic de-rating function automatically reduces the output frequency by 30% of the nominal motor speed when the inverter detects an overheat condition.

Automatic de-rating function depends on the automatic carrier frequency reduction selection (11-03).

If automatic carrier frequency reduction is disabled (11-03=0), the output frequency is reduced by 30% of the nominal motor speed when an overheat condition is detected.

If automatic carrier frequency reduction is enabled (11-03=1), the output frequency is reduced by 30% of the nominal motor speed when the carrier frequency is at its minimum setting.

11-29=0: Auto de-rating selection disabled, carrier frequency is based on 11-01 or 11-03.

11-29=1: Auto de-rating selection is enabled.

| | |
|--------------|--|
| 11-30 | Variable Carrier Frequency Max. Limit |
| Range | 【0~16】 KHz |
| 11-31 | Variable Carrier Frequency Min. Limit |
| Range | 【0~16】 KHz |

| | |
|--------------|---|
| 11-32 | Variable Carrier Frequency Proportional Gain |
| Range | 【00~99】 |

Carrier frequency method depends on the selected control mode.

| Control Mode | Variable Carrier Frequency (11-01 = 0) | Fixed Carrier Frequency (11-01 = 2-16 kHz) |
|---------------------|---|---|
| V/F | Available | Available |
| SLV | Not available | Available |

Variable carrier frequency can be adjust with parameter 11-30 ~ 11-32.

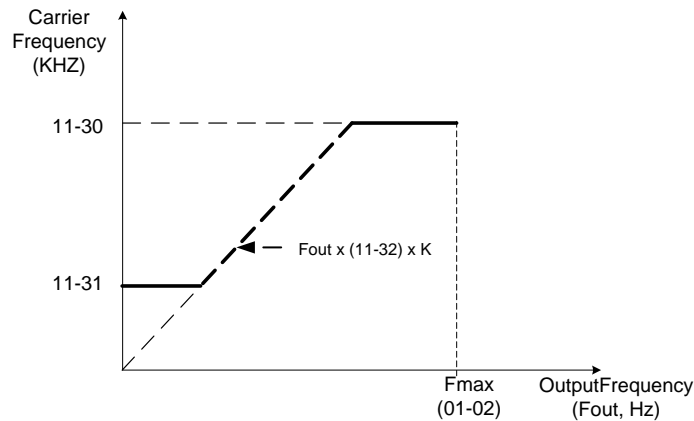

K is a coefficient; the value of K is based on the following based on the maximum carrier frequency:

K=1: when 11-30 < 5 KHz

K=2: when 10 KHz > 11-30 ≥ 5 KHz

K=3: when 11-30 ≥ 10KHz

Notes:

- In V/F control mode if the speed and torque are constant, the variable carrier frequency mode (11-01=0) can be selected to reduce the carrier frequency based on output frequency.
- If the carrier frequency proportional gain (11-32) > 6 and 11-30 < 11-31, error message "SE01" out of range will appear on the keypad.
- If the minimum limit (11-31) is set higher than the maximum limit (11-30), the minimum limit will be ignored and the carrier frequency will be set at the highest limit (11-30).
- In fixed carrier frequency mode (11-01 = 2-16) parameters 11-30, 11-31 and 11-32 are not used.
- In SLV control mode, the maximum limit of the carrier frequency is fixed at 11-30.

| | |
|--------------|---|
| 11-41 | Frequency Reference Loss Operation Selection |
| Range | 【0】 : Decelerate to Stop when Reference Frequency Disappears 【1】 : Operation is Set by 11-42 when Reference Frequency Disappears |
| 11-42 | Operation Frequency after Frequency Reference Loss |
| Range | 【0.0~100.0】 % |

A reference frequency loss is detected when the frequency command falls 90% within 360ms.

When 11-41=1, main frequency command is compared to the previous value during the 360ms.

When the frequency loss occurs, inverter will operate depending on the following estimated frequency command.

Reference frequency command = the frequency command prior to frequency loss × the level set in parameter 11-42

Descriptions of frequency loss function:

- 1) When inverter is on operation and source of selected analog command disappears, the command acts depending on the setting of parameter 11-42.
- 2) When reference command restores to the level prior to frequency loss, inverter will restore to the previous state.

Notes:

1. Frequency command (11-42) is corresponding to the maximum output frequency of motor 1 (01-02) when reference frequency disappears.
2. The frequency reference loss can only be used for analog signals (1: AI1; 7: AI2) set by the main frequency source (00-05).

Refer to Fig.4.3.81 for the operation of multi-function digital output (03-11~03-12) when a frequency reference loss occurs.

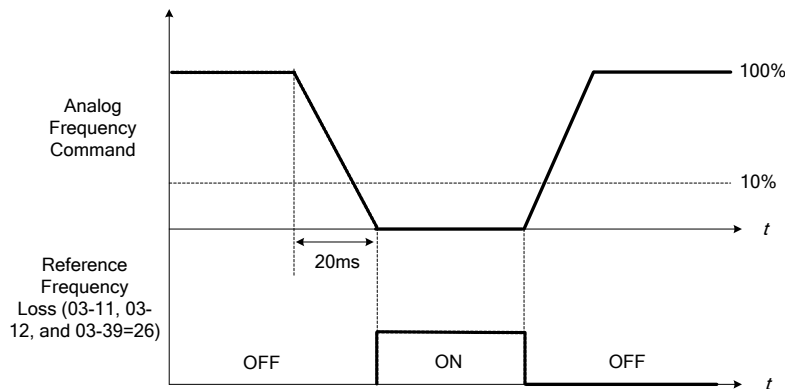

Figure 4.3.81 Operation for reference frequency loss

| | |
|--------------|-------------------------------------|
| 11-43 | Hold Frequency at Start |
| Range | 【0.0~400.0】 Hz |
| 11-44 | Frequency Hold Time at Start |
| Range | 【0.0~10.0】 Sec |
| 11-45 | Hold Frequency at Stop |
| Range | 【0.0~400.0】 Hz |
| 11-46 | Frequency Hold Time at Stop |
| Range | 【0.0~10.0】 Sec |

The hold function is used to temporarily hold the reference frequency in order to prevent stalling the motor or preventing an over current condition during starting or stopping due to load conditions.

During start the inverter will operate at the hold frequency at start for the time specified in the parameter 11-44 in order to establish the magnetic flux.

Note: Acceleration and deceleration time do not include the start and stop hold time. Refer to the Fig. 4.3.82.

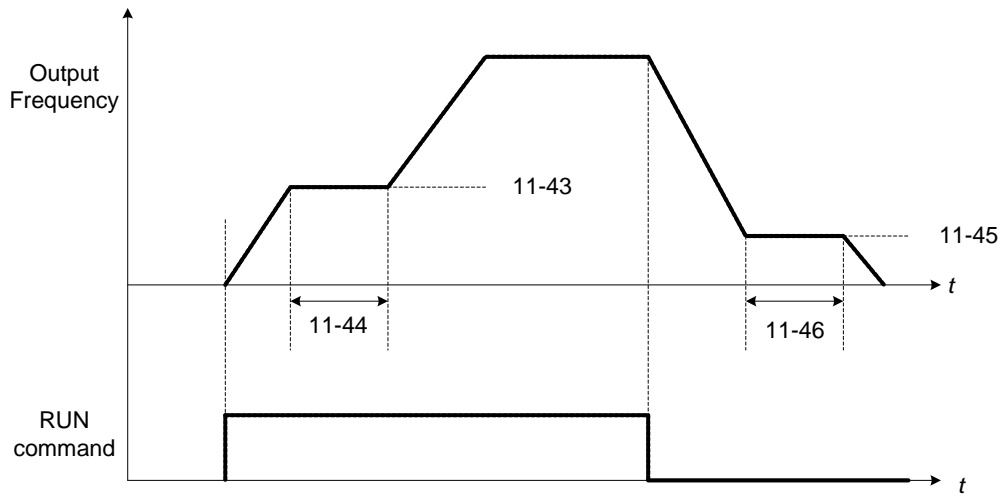

Figure 4.3.82 Reserved function

When the inverter is in stop mode, this function can also be used to prevent wind milling. In addition, it can be used for the purpose of braking using the motor to consume the braking energy resulting in a better controlled stop. Refer to the DC brake parameter 07-16 for DC braking during start.

Notes:

- The hold function at start is inactive when the hold frequency at start (11-43) is set to a value less than Fmin (01-08).
- The hold function at stop is inactive when the hold frequency at stop (11-45) is set to a value less than Fmin (01-08).

| | |
|--------------|--|
| 11-47 | KEB Deceleration Time |
| Range | 【0.0~25.5】 Sec |
| 11-48 | KEB Detection Level |
| Range | 【190~210】 V : 230V 【380~420】 V : 460V |

KEB function can be used to keep the inverter from tripping on a under voltage condition due to a momentary power-loss. To enable the KEB function set parameter 11-47 to a value greater than 0.0 sec.

Upon detection of a power-loss the inverter uses the KEB deceleration time (11-47) to decelerate the motor and using the regenerative energy from the motor to maintain the DC-bus at a nominal level.

11-48: KEB detection level

If the DC-bus voltage falls below the value set in 11-48, the KEB is activated and the inverter starts decelerating according to the value set in 11-47.

To accelerate back to the original output frequency one of the digital inputs (03-00 to 03-05) set for 48 (KEB acceleration) has to be activated and the DC voltage has to rise above 11-48 + delta V (Delta V = +10V for 230V series, Delta V = +20 V for 460V series).

Refer to the example in Fig.4.3.83.

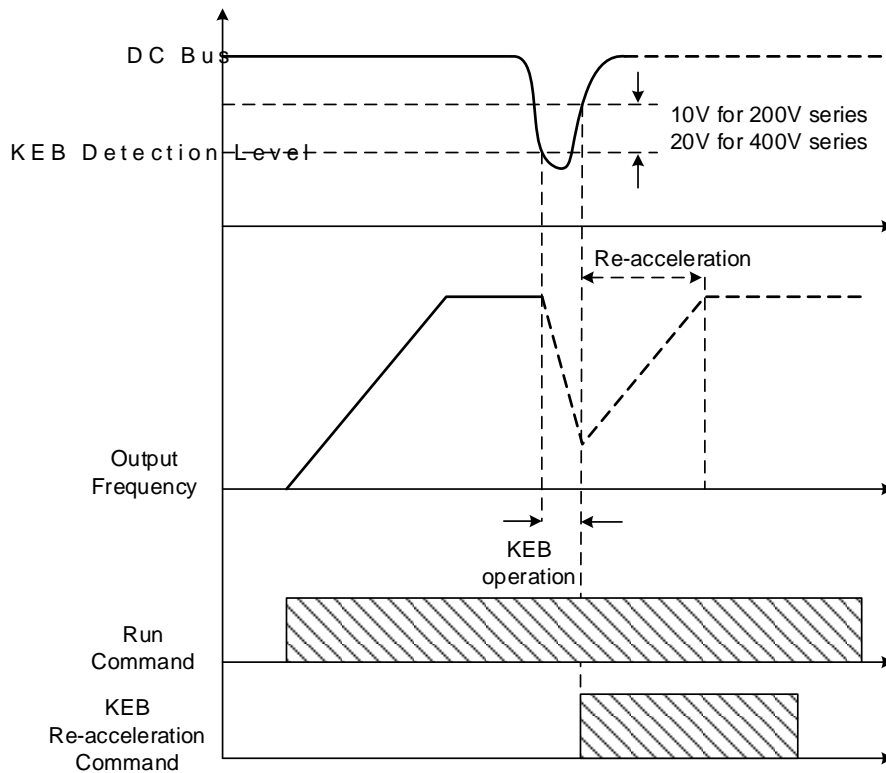

Figure 4.3.83 KEB operation

| | |
|-------|---|
| 11-51 | Braking Selection of Zero Speed |
| Range | 【0】 : Disable 【1】 : Enable |

11-51: Operation selection of zero-speed braking

In V/F control mode, the DC braking operation can be used to hold the motor shaft.
Set 11-51 to select zero-speed braking operation to 1 to enable this function.

To use DC braking operation set parameter 00-02 (operation command selection) to 1 and parameter 00-05 (frequency reference selection) to 1, the operation command and frequency reference are now set for external control. When the frequency reference is 0V (or less than 4mA), and the operation command is turned on, the zero-speed 'DC' braking operation is activated and holding torque is generated using DC braking.

Refer to Fig.4.3.84 for more information on zero-speed DC braking operation.

Note: DC braking 07-07 is limited to 20% of the inverter rated current.

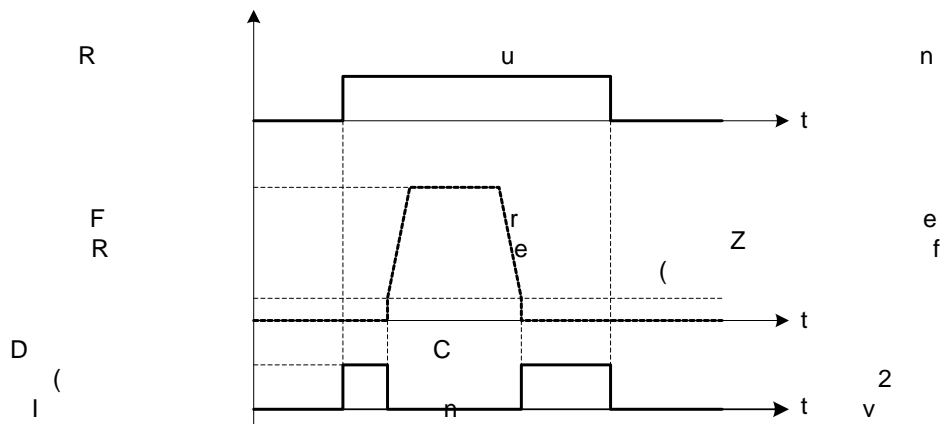

Figure 4.3.84 Zero-speed braking operation

| | |
|--------------|---|
| 11-54 | Output kwh Initialization |
| Range | 【0】 : Do not Clear Output KWH 【1】 : Clear Output KWH |

Reset the cumulative energy (KWHr) (12-67) and the cumulative energy (MWHr) (12-68) via parameter 11-54.

| | |
|--------------|---|
| 11-55 | STOP Key Selection |
| Range | 【0】 : Stop Key is Disabled when the Operation Command is not Provided by Keypad. 【1】 : Stop Key is Enabled when the Operation Command is not Provided by Keypad. |

11-55= 0: Stop button disabled when operation command is set for terminals (00-02=1) or communication (00-02=3).

11-55= 1: Stop button enabled.

| | |
|--------------|---|
| 11-56 | UP/DOWN Selection |
| Range | 【0】 : When UP/DOWN on Keypad is Disabled, ENTER must be pressed after changing the Frequency Reference. 【1】 : When UP/DOWN on Keypad is Enabled, Frequency Reference will change immediately upon pressing the UP or Down key. |

11-56= 0: Changing the reference frequency on the keypad in UP/DOWN control requires the ENTER button to be pressed for the inverter to accept the modified reference frequency.

11-56= 1: Changing the reference frequency on the keypad in UP/DOWN control immediately changes the reference frequency and there for the output frequency.

Note: The reference frequency can be changed (up or down) via the keypad or by setting one of multi-functional digital input terminals (03-00 to 03-05) to 8 and 9. Refer to instructions of (03-00 to 03-05 = 8 or 9).

| | |
|--------------|---|
| 11-58 | Record Reference Frequency |
| Range | 【0】 : Disable 【1】 : Enable |

This function is enabled only when one of multi-function digital input terminals (03-00 to 03-05) is set to 11 (ACC / DEC disabled) or two MFIT are set to 8 and 9 (up / down). Refer to the figure 4.3.18 to disable acceleration / deceleration, and figure 4.3.17 for up / down operation.

| | |
|--------------|-------------------------------------|
| 11-59 | Anti-hunting Protection Gain |
| Range | 【0.01~2.50】 |

Gradually increase the setting value with the unit of 0.01 when the motor is driven leading to the occurrence of oscillation under the state of normal duty.

| | |
|--------------|---|
| 11-60 | Upper Limit of Anti-hunting Protection |
| Range | 【0~100】 % |

Function of prevention of oscillation upper limit is required to be within the setting value.

| | |
|--------------|---|
| 11-61 | Filter Time of Anti-hunting Protection |
| Range | 【0~100】 |

Adjust the response of oscillation function. That is, adjust once delay time parameter of prevention oscillation function.

| | |
|--------------|--|
| 11-62 | Prevention of Oscillation Selection |
| Range | 【0】 : Mode 1 【1】 : Mode 2 |

11-62=0: The response to prevention oscillation is slower.

11-62=1: The response to prevention oscillation is faster.

| | |
|--------------|---|
| 11-63 | Flux-Enhancing Selection |
| Range | 【0】 : Disable 【1】 : Enable |

11-63=0: Flux-enhancing disabled.

11-63=1: Flux-enhancing enabled.

| |
|--|
| Group 12: Monitoring Parameters |
|--|

| | | |
|--------------|---|---|
| 12-00 | Display Screen Selection (LED) | |
| Range | Highest bit => <u>0 0 0 0</u> <= lowest bit The value range of each bit is 0~7 from the highest bit to the lowest bit, | |
| | 【0】 : No display 【2】 : Output Voltage 【4】 : heatsink Temperature 【6】 : AI1 Value | 【1】 : Output Current 【3】 : DC Bus Voltage 【5】 : PID Feedback 【7】 : AI2 Value |

Note: The highest bit is used for power-up monitor. The 4 least significant bits can be used to customize the display sequence see section 4.1.3.

| | | |
|--------------|--|--|
| 12-01 | PID Feedback Display Mode (LED) | |
| Range | 【0】 : Display the Feedback Value by Integer (xxx) 【1】 : Display the Feedback Value by the Value with First Decimal Place (xx.x) 【2】 : Display the Feedback Value by the Value with Second Decimal Places (x.xx) | |
| 12-02 | PID Feedback Display Unit Setting (LED) | |
| Range | 【0】 : xxxxx(no unit) 【1】 : xxxPb(pressure) 【2】 : xxxFL(flow) | |

| | | |
|--------------|--|--|
| 12-03 | Line Speed Display (LED) | |
| Range | 【0~65535】 RPM | |
| 12-04 | Line Speed Display Mode (LED) | |
| Range | 【0】 : Display Inverter Output Frequency 【1】 : Line Speed Display at Integer.(xxxxx) 【2】 : Line Speed Display at One Decimal Place. (xxxx.x) 【3】 : Line Speed Display at Two Decimal Places. (xxx.xx) 【4】 : Line Speed Display at Three Decimal Places. (xx.xxx) | |

12-04=0

Inverter displays the line speed at stop, operation or the modification of frequency.

12-04≠0

12-03 is set to the maximum line speed and corresponds to the maximum output frequency.

For example, if the line speed display of 12-03 is 1800, the keypad display is 900 when frequency output is 30Hz.

| | |
|--------------|---|
| 12-05 | Status Display of Digital Input Terminal (LED/LCD) |
| Range | Read-only |

Terminals S1-S6 are represented using two segments of each digit. Segment turns on when input is active. The bottom segments of each of the first three digits are used to represent the digital outputs (R1, R2, R3). Segments turn on when output is active.

When operation command is changed to PLC, press RUN key and it will light up.

Example1: S1~S6, R1, R2 and R3 are ON

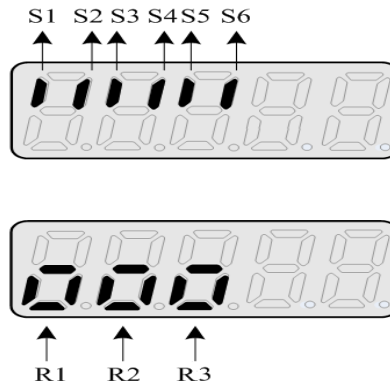

Example2: S1~S6, R1, R2 and R3 are OFF

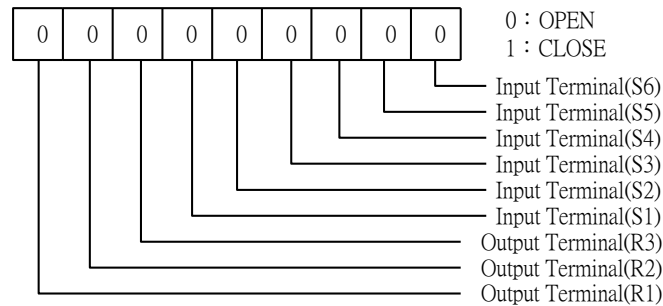

Note: Refer to section 4.3 for other monitor parameters 12-11~12-79.

Monitor parameters 12-67 (KWHr) and 12-68 (MWHr) is the display of accumulative energy.

Note: Parameter 11-54 can clear the monitor parameter.

Monitor parameter 12-76 (No-load voltage) is required to refer to the descriptions of parameter 02-09(Motor 1 excitation current) and 17-09 (Motor excitation current).

| |
|--|
| Group 13 Maintenance Function Group |
|--|

| | |
|--------------|----------------------------------|
| 13-00 | Inverter Rating Selection |
| Range | 00H~FFH |

| Inverter model | 13-00 display | Inverter model | 13-00 display |
|----------------|---------------|----------------|---------------|
| F510-2005-XXX | 205 | F510-4005-XXX | 405 |
| F510-2008-XXX | 208 | F510-4008-XXX | 408 |
| F510-2010-XXX | 210 | F510-4010-XXX | 410 |
| F510-2015-XXX | 215 | F510-4015-XXX | 415 |
| F510-2020-XXX | 220 | F510-4020-XXX | 420 |
| F510-2025-XXX | 225 | F510-4025-XXX | 425 |
| F510-2030-XXX | 230 | F510-4030-XXX | 430 |
| F510-2040-XXX | 240 | F510-4040-XXX | 440 |
| F510-2050-XXX | 250 | F510-4050-XXX | 450 |
| F510-2060-XXX | 260 | F510-4060-XXX | 460 |
| F510-2075-XXX | 275 | F510-4075-XXX | 475 |
| F510-2100-XXX | 2100 | F510-4100-XXX | 4100 |
| F510-2125-XXX | 2125 | F510-4125-XXX | 4125 |
| F510-2150-XXX | 2150 | F510-4150-XXX | 4150 |
| F510-2175-XXX | 2175 | F510-4175-XXX | 4175 |
| | | F510-4215-XXX | 4215 |
| | | F510-4250-XXX | 4250 |

| | |
|--------------|-------------------------|
| 13-01 | Software Version |
| Range | 0.0-9.9 |

| | |
|--------------|---|
| 13-03 | Cumulative Operation Hours 1 |
| Range | 【0~23】 hours |
| 13-04 | Cumulative Operation Hours 2 |
| Range | 【0~65535】 days |
| 13-05 | Selection of Cumulative Operation Time |
| Range | 【0】 : Cumulative time at power on 【1】 : Cumulative time during operation |

13-05= 0: Inverter logs the time while the inverter is powered-up.

13-05= 1: Inverter logs the time when the inverter is running.

| | |
|--------------|---|
| 13-06 | Parameters Locked |
| Range | 【0】 : Parameters other than 13-06 are read-only 【1】 : Only user parameter are enabled. 【2】 : All parameters are writable. |
| 13-07 | Parameter Password Function |
| Range | Reserved |
| 13-08 | Restore Factory Setting |
| Range | 【0】 : No Initialization 【1】 : Reserved 【2】 : 2 Wire Initialization (220/440V, 60Hz) 【3】 : 3 Wire Initialization (220/440V, 60Hz) 【4】 : 2 Wire Initialization (230/415V, 50Hz) 【5】 : 3 Wire Initialization (230/415V, 50Hz) 【6】 : 2 Wire Initialization (200/380V, 50Hz) 【7】 : 3 Wire Initialization (200/380V, 50Hz) 【8】 : PLC Initialization 【9】 : 2 Wire Initialization (230V/460V, 60Hz) 【10】 : 3 Wire Initialization (230V/460V, 60Hz) 【Others】 : Reserved |

Use parameter 13-08 to initialize the inverter to factory default. It is recommended to write down the modified parameters before initializing the inverter. After initialization, the value of 13-08 will return to zero automatically.

13-08=2: 2-wire initialization (220V/440V)

Multi-function digital input terminal S1 controls forward operation / stop command, and S2 controls reverse operation / stop command. Refer to Fig.4.3.1.

Inverter input voltage (01-14) is automatically set to 220V (230V class) or 440V (460V class).

Inverter maximum frequency (01-12) is automatically set to 60Hz.

13-08=3: 3-wire initialization (220V/440V)

Multi-function digital input terminal S5 controls the forward / reverse direction, terminal S1 (Start Command) and S2 (Normally Closed Stop Command) are set for 3-wire start/stop. Refer to Figure 4.3.2 and Figure 4.3.3 for 3-wire type operation mode.

Inverter input voltage (01-14) is automatically set to 220V (230V class) or 440V (460V class).

Inverter maximum frequency (01-12) is automatically set to 60Hz.

13-08=4: 2-wire initialization (230V/415V)

Multi-function digital input terminal S1 controls forward operation / stop command, and S2 controls reverse operation / stop command. Refer to Fig.4.3.1.

Inverter input voltage (01-14) is automatically set to 230V (230V class) or 415V (460V class).

Inverter maximum frequency (01-12) is automatically set to 50Hz.

13-08=5: 3-wire initialization (230V/415V)

Multi-function digital input terminal S5 controls the forward / reverse direction, terminal S1 (Start Command) and S2 (Normally Closed Stop Command) are set for 3-wire start/stop.

Inverter input voltage (01-14) is automatically set to 230V (230V class) or 415V (460V class).

Inverter maximum frequency (01-12) is automatically set to 50Hz.

13-08=6: 2-wire initialization (230V/380V)

Multi-function digital input terminal S1 controls forward operation / stop command, and S2 controls reverse operation / stop command. Refer to Fig.4.3.1.

Inverter input voltage (01-14) is automatically set to 230V (230V class) or 380V (460V class).

Inverter maximum frequency (01-12) is automatically set to 50Hz.

13-08=7: 3-wire initialization (230V/380V)

Multi-function digital input terminal S5 controls the forward / reverse direction, terminal S1 (Start Command) and S2 (Normally Closed Stop Command) are set for 3-wire start/stop.

Inverter input voltage (01-14) is automatically set to 230V (230V class) or 380V (460V class).

Inverter maximum frequency (01-12) is automatically set to 50Hz.

13-08=8: PLC initialization

Clear built-in PLC ladder logic and related values.

13-08=9: 2 wire initialization (230V/460V, 60Hz)

Setting similar to 2 wire Initialization (13-08=2). The input voltage (01-14) is set to 230V (230V class) or 460V (460V class) automatically and the maximum frequency of 01-12 is set to 60Hz.

13-08=10: 3 wire initialization (230V/460V, 60Hz)

It is the same as 3 wire Initialization (13-08=3). The input voltage (01-14) will be set to 230V (230V class) or 460V (460V class) automatically and the maximum frequency of 01-12 will be set to 60Hz automatically.

Note: The default value of 13-08 is 9 (230V/460V, 60Hz) for F510 Filter Model (IP20).

| 13-09 | Fault History Clearance Function |
|-------|---|
| Range | 【0】 : Do not Clear Fault History 【1】 : Clear Fault History |

13-09=1: Clear inverter fault history including (12-11~12-15/12-45~12-64)

| 13-10 | Password Function 2 |
|-------|---------------------|
| Range | 0 ~ 9999 |

| | |
|--------------|----------------------|
| 13-11 | C/B CPLD Ver. |
| Range | 【0.00~9.99】 |

This parameter displays CPLD version on the control board.

| | |
|--------------|-----------------------|
| 13-12 | Option Card Id |
| Range | 【0~255】 |

Displays option card ID code:

- 【0】 : None**
- 【1】 : PG-L**
- 【2】 : PG-O**
- 【3】 : PG-PM**
- 【4】 : PG-PMS**
- 【5】 : PG-PMR**
- 【6】 : CM-P**
- 【7】 : CM-C**
- 【8】 : IO-8DO**

| | |
|--------------|------------------------------|
| 13-13 | Option Card CPLD Ver. |
| Range | 【0.00~9.99】 |

This parameter displays option card CPLD version.

| | |
|--------------|--|
| 13-14 | Fault Storage Selection |
| Range | 【0】 : Auto Restart Fault Messages are not saved in fault history during Auto-Restart. 【1】 : Auto Restart Fault Messages are saved in fault history during Auto-Restart. |

13-14=0,

Fault messages are not saved in fault history (12-46~12-49) while the auto restart function is active.

13-14=1,

Fault messages are saved in fault history (12-46~12-49) while the auto restart function is active.

Group 14: PLC Setting Parameters

| | |
|--------------|-------------------------|
| 14-00 | T1 Set Value 1 |
| 14-01 | T1 Set Value 2 (Mode 7) |
| 14-02 | T2 Set Value 1 |
| 14-03 | T2 Set Value 2 (Mode 7) |
| 14-04 | T3 Set Value 1 |
| 14-05 | T3 Set Value 2 (Mode 7) |
| 14-06 | T4 Set Value 1 |
| 14-07 | T4 Set Value 2 (Mode 7) |
| 14-08 | T5 Set Value 1 |
| 14-09 | T5 Set Value 2 (Mode 7) |
| 14-10 | T6 Set Value 1 |
| 14-11 | T6 Set Value 2 (Mode 7) |
| 14-12 | T7 Set Value 1 |
| 14-13 | T7 Set Value 2 (Mode 7) |
| 14-14 | T8 Set Value 1 |
| 14-15 | T8 Set Value 2 (Mode 7) |
| Range | 【0~9999】 |

| | |
|--------------|------------------|
| 14-16 | C1 Set Value |
| 14-17 | C2 Set Value |
| 14-18 | C3 Set Value |
| 14-19 | C4 Set Value |
| 14-20 | C5 Set Value |
| 14-21 | C6 Set Value |
| 14-22 | C7 Set Value |
| 14-23 | C8 Set Value |
| Range | 【0~65535】 |

| | |
|--------------|------------------|
| 14-24 | AS1 Set Value 1 |
| 14-25 | AS1 Set Value 2 |
| 14-26 | AS1 Set Value 3 |
| 14-27 | AS2 Set Value 1 |
| 14-28 | AS2 Set Value 2 |
| 14-29 | AS2 Set Value 3 |
| 14-30 | AS3 Set Value 1 |
| 14-31 | AS3 Set Value 2 |
| 14-32 | AS3 Set Value 3 |
| 14-33 | AS4 Set Value 1 |
| 14-34 | AS4 Set Value 2 |
| 14-35 | AS4 Set Value 3 |
| Range | 【0~65535】 |

| | |
|--------------|------------------|
| 14-36 | MD1 Set Value 1 |
| 14-37 | MD1 Set Value 2 |
| 14-38 | MD1 Set Value 3 |
| 14-39 | MD2 Set Value 1 |
| 14-40 | MD2 Set Value 2 |
| 14-41 | MD2 Set Value 3 |
| 14-42 | MD3 Set Value 1 |
| 14-43 | MD3 Set Value 2 |
| 14-44 | MD3 Set Value 3 |
| 14-45 | MD4 Set Value 1 |
| 14-46 | MD4 Set Value 2 |
| 14-47 | MD4 Set Value 3 |
| Range | 【0~65535】 |

Please refer to section 4.5 for more details of built-in PLC function.

| |
|--|
| Group 15: PLC Monitoring Parameters |
|--|

| | |
|--------------|-----------------------------|
| 15-00 | T1 Current Value 1 |
| 15-01 | T1 Current Value 2 (Mode 7) |
| 15-02 | T2 Current Value 1 |
| 15-03 | T2 Current Value 2 (Mode 7) |
| 15-04 | T3 Current Value 1 |
| 15-05 | T3 Current Value 2 (Mode 7) |
| 15-06 | T4 Current Value 1 |
| 15-07 | T4 Current Value 2 (Mode 7) |
| 15-08 | T5 Current Value 1 |
| 15-09 | T5 Current Value 2 (Mode 7) |
| 15-10 | T6 Current Value 1 |
| 15-11 | T6 Current Value 2 (Mode 7) |
| 15-12 | T7 Current Value 1 |
| 15-13 | T7 Current Value 2 (Mode 7) |
| 15-14 | T8 Current Value 1 |
| 15-15 | T8 Current Value 2 (Mode 7) |
| Range | 【0~9999】 |

| | |
|--------------|------------------|
| 15-16 | C1 Current Value |
| 15-17 | C2 Current Value |
| 15-18 | C3 Current Value |
| 15-19 | C4 Current Value |
| 15-20 | C5 Current Value |
| 15-21 | C6 Current Value |
| 15-22 | C7 Current Value |
| 15-23 | C8 Current Value |
| Range | 【0~65535】 |

| | |
|--------------|-------------------------|
| 15-24 | AS1 Results |
| 15-25 | AS2 Results |
| 15-26 | AS3 Results |
| 15-27 | AS4 Results |
| 15-28 | MD1 Results |
| 15-29 | MD2 Results |
| 15-30 | MD3 Results |
| 15-31 | MD4 Results |
| 15-32 | TD Current Value |
| Range | 【0~65535】 |

| |
|--|
| Group 16: LCD Function Parameters |
|--|

| | |
|--------------|--------------------------------|
| 16-00 | Main Screen Monitoring |
| Range | 【5~79】 |
| 16-01 | Sub-Screen Monitoring 1 |
| Range | 【5~79】 |
| 16-02 | Sub-Screen Monitoring 2 |
| Range | 【5~79】 |

At power-up the inverter shows two monitor section on the display, main monitor section and t two sub-screen monitor sections (smaller font).

Choose the monitor signal to be displayed on the main-screen monitor screen using parameter 16-00, and the monitor signals to be displayed on the sub-screen monitor with parameters 16-01 and 16-02, similar to monitor parameters 12-5 ~ 12-79.

Note: The setting value of 16-00, 16-01 and 16-02 can be modified, except in PID mode (refer to the setting description of parameter 10-03) and PUMP modes (refer to the setting description of parameter 23-00).

| | |
|--------------|--|
| 16-03 | Selection of Display Unit |
| Range | 【0】 : Display unit is Hz (Resolution is 0.01Hz) 【1】 : Display unit is % (Resolution is 0.01%) 【2】 : Rpm display; to calculate motor poles for V/f and SLV are set by 02-07, PM mode is by 22-03 【40~9999】 : 100% is XXXX with no decimals (integer only) 【10001~19999】 : 100% is XXX.X with 1 decimal 【20001~29999】 : 100% is XX.XX with 2 decimals 【30001~39999】 : 100% is X.XXX with 3 decimals |
| 16-04 | Selection of Engineering Unit |
| Range | 【0】 : No Unit 【1】 : FPM 【2】 : CFM 【3】 : PSI 【4】 : GPH 【5】 : GPM 【6】 : IN 【7】 : FT 【8】 : /s 【9】 : /m 【10】 : /h 【11】 : °F 【12】 : inW 【13】 : HP 【14】 : m/s 【15】 : MPM 【16】 : CMM 【17】 : W 【18】 : KW 【19】 : m |

| | |
|--|---|
| | 【20】 : °C 【21】 : RPM 【21】 : RPM 【22】 : Bar 【23】 : Pa |
|--|---|

16-03: Display unit of digital operator

Set the units of the following items to be displayed, the frequency reference (05-01, 00-18, 06-01~06-15) and the monitoring frequency 12-16, 12-17 (Output frequency)

16-04: Display unit of engineering

When 16-03 = 00040-39999, engineering units are enabled. The displayed set range and the frequency range of unit (05-01, 06-01~06-15) as well as the monitoring frequency (12-16, 12-17) are changed by parameters 16-04 and 16-03.

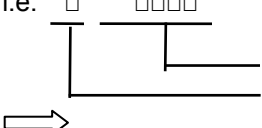
| 16-03 | Set / displayed contents | | | |
|---------------------|--|--------------------------------|--|--|
| 0 | 0.01 Hz | | | |
| 1 | 0.01 % (maximum output frequency 01-02=100%) | | | |
| 2 | RPM (RPM = 120 x reference frequency / numbers of motor pole. The numbers of motor pole is set by 02-07 for control modes of V/F or SLV and is set by 22-03 in PMSLV.) | | | |
| 00040 - 39999 | Set the decimal point by using the fifth place. i.e. $\square \quad \square\square\square\square$  <div style="display: inline-block; vertical-align: middle; margin-left: 20px;"> Sets full display scaling excluding decimals Set the number of decimal places </div> | | | |
| | 00040 - 09999 : $\square\square\square\square$ (Integer only e.g. 1000) 10001 - 19999 : $\square\square\square.\square$ (1 decimal place e.g. 10.0) 20001 - 29999 : $\square\square.\square\square$ (2 decimal places, e.g. 10.00) 30001 - 39999 : $\square.\square\square\square$ (3 decimal places, e.g. 10.000) | | | |
| | <example> | | | |
| | 16-03 | Display | Display unit | Display example |
| | 00040 - 09999 | $\square\square\square\square$ | use 16-04 setting | Example: 100 % speed is 0200 > set 16-03=00200 (from 05-01, 06-01 to 06-15, set range from 0040 to 9999). > set 16-04=0 (no unit) |
| 10001 - 19999 | $\square\square\square.\square$ | | Example: 100 % speed is 200.0 CFM > set 16-03=12000 (05-01, 06-01 to 06-15, set range from 0000 to 9999). > set 16-04=2 (CFM) > 60% speed will be displayed as 120.0 CFM | |
| 20001 - 29999 | $\square\square.\square\square$ | | Example: 100 % speed is 65.00°C > set 16-03=26500 (05-01, 06-01 to 06-15, set range from 0000 to 9999) > set 16-04=20 (°C) > 60% of speed is displayed as 39.00 °C | |
| 30001 - 39999 | $\square.\square\square\square$ | | Example: 100 % speed is 2.555 m/s > set 16-03=32555 > set 16-04=14 (m/s) > 60% speed is displayed as 1.533 m/s | |

| | |
|--------------|----------------------|
| 16-05 | LCD Backlight |
| Range | 【0~7】 |

Adjust the screen contrast of the digital operator. If it is set to 0, the screen backlight is turned off.

| | |
|--------------|---|
| 16-07 | Copy Function Selection |
| Range | 【0】 : Disable (Do not copy parameters) 【1】 : Read (read inverter parameters and save to the operator) 【2】 : Write (write the operator parameters to inverter) 【3】 : Verify (Compare parameters of inverter and operator) |
| 16-08 | Selection of Allowing Reading |
| Range | 【0】 : Disable (Do not allow to read inverter parameters and save to the operator) 【1】 : Enable (Allow to read inverter parameters and save to the operator) |

LCD digital operator with built-in memory (EEPROM) can be used to store and retrieve parameters:

- (1) Read: Save inverter parameters to the digital operator (INV → OP).
- (2) Write: Write the parameters from the digital operator to the inverter and save (OP → INV).
- (3) Verify: Compare the inverter parameters against the parameters in the digital operator.

16-07=0: No action

16-07=1: Read (all parameters are copied from the inverter to the keypad).

16-07=2: Write (all parameter are copied from the keypad to the inverter).

16-07=3: Verify (Compare the set value of the inverter to the parameter of the digital operator).

Set 16-08 = 0, to prevent the saved parameter data stored in the digital operator from accidentally being overwritten.

When parameter 16-08=0 and the read operation is executed (16-07=1) a warning message of "RDP Read Prohibited" will be displayed on the keypad and the read operation is cancelled.

Refer to the following steps for copy function operation.

For the write-in operation requires the following items to match.

- (1) Software version
- (2) Control method
- (3) Inverter type
- (4) Inverter rated capacity and voltage

Set one of the parameters 03-00 to 03-05 (multi-function digital input selection) to 49 (Enable the parameter write-in function) to enable or disable the parameter write-in function.

When terminal is active, parameters can be copied from the digital operator to the inverter. When the terminal is not active inverter parameters are prohibited from write-in, excluding the reference frequency (00-05).

Note: Set parameter 16-11 (RTC date setting) and 16-12 (RTC time setting) after parameters are copied from the operator to the inverter (OP→INV).

■ **READ: Copy inverter parameters to the keypad**

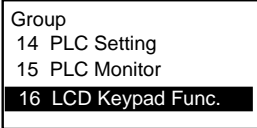
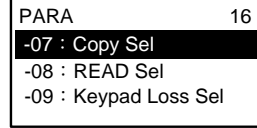
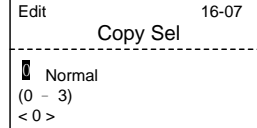
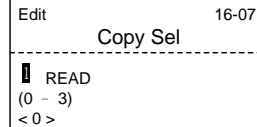
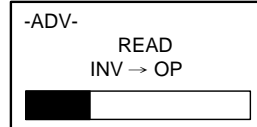
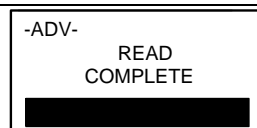
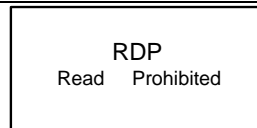
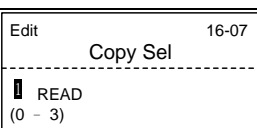
| Steps | LCD Display (English) | Description |
|-------|---|---|
| 1 |  | Select the copy function group (16) from the group menu. |
| 2 |  | Press the Read / Enter key and select parameter (16-07) copy sel. |
| 3 |  | Press the Read / Enter key to display the data setting / read screen (LCD display is inverted). |
| 4 |  | Change the set value to 1 (read) by using the up arrow key. |
| 5 |  | <ul style="list-style-type: none"> • Use Read / Enter key to enable the read operation, the display is shown as the left. • The bottom of LCD display will show a bar to indicate the read progress s. |
| 6 |  | "READ COMPLETE" will be displayed on the keypad when reading was successful. |
| |  | <ul style="list-style-type: none"> • The error message of "RDP Read Prohibited" may occur on the keypad when reading parameters from the inverter is prohibited. • If the error is displayed, press any key to remove the error message and go back to parameter 16-07. |
| 7 |  | When DSP/FUN key is pressed, the display returns to parameter 16-07. |

■ **WRITE: Copy Keypad parameters to the Inverter**

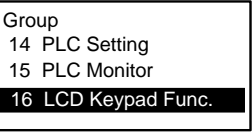
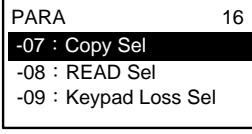
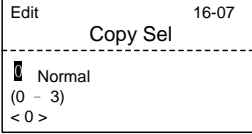
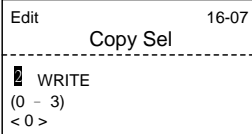
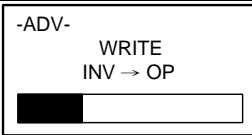
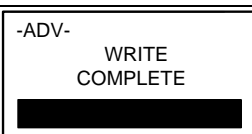
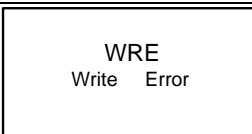
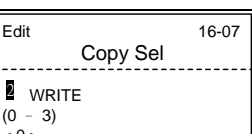
| Steps | LCD Display (English) | Description |
|-------|---|--|
| 1 |  | Select the copy function group (16) from the group menu. |
| 2 |  | Press the Read / Enter key and select parameter (16-07) copy sel. |
| 3 |  | Press the Read / Enter key to display the data setting / read screen (LCD display is inverted). |
| 4 |  | Change the set value to 2 (write) by using the up arrow key. |
| 5 |  | <ul style="list-style-type: none"> • Use Read / Enter key to enable the read operation, the display is shown as the left. • The bottom of LCD display will show a bar to indicate the read progress. |
| 6 |  | "WRITE COMPLETE" will be displayed on the keypad when writing was successful. |
| |  | <ul style="list-style-type: none"> • The error message of "WRE Write Error " may occur on the keypad when writing parameters to the inverter is prohibited. • If the error is displayed, press any key to remove the error message and go back to parameter 16-07. |
| 7 |  | When DSP/FUN key is pressed, the display returns to parameter 16-07. |

■ **Verify: Compare Inverter Parameters against Keypad Parameters.**

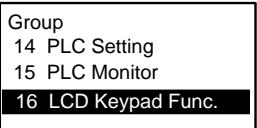
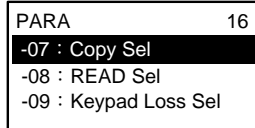
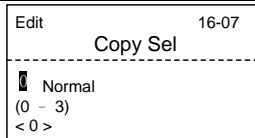
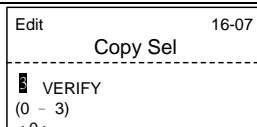
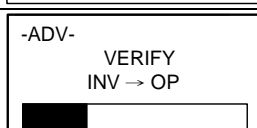
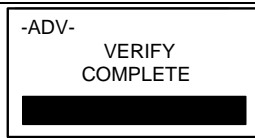
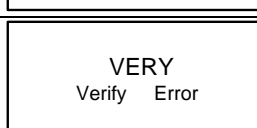
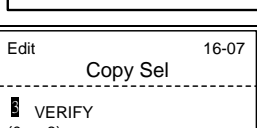
| Steps | LCD Display (English) | Description |
|-------|---|--|
| 1 |  | Select the copy function group (16) from the group menu. |
| 2 |  | Press the Read / Enter key and select parameter (16-07) copy sel. |
| 3 |  | Press the Read / Enter key to display the data setting / read screen (LCD display is inverted). |
| 4 |  | Change the set value to 3 (verify) by using the up arrow key. |
| 5 |  | <ul style="list-style-type: none"> • Use Read / Enter key to enable the read operation, the display is shown as the left. • The bottom of LCD display will show a bar to indicate the read progress. |
| 6 |  | “VERIFY COMPLETE” will be displayed on the keypad when writing was successful. |
| |  | <ul style="list-style-type: none"> • The error message of “VERY Verify Error ” may occur on the keypad when writing parameters to the inverter is prohibited. • If the error is displayed, press any key to remove the error message and go back to parameter 16-07. |
| 7 |  | When DSP/FUN key is pressed, the display returns to parameter 16-07. |

| | |
|--------------|--|
| 16-09 | Selection of Operator Removed (LCD) |
| Range | 【0】 : Keep Running 【1】 : Stop |

16-09=0: Continue operating when keypad is removed.

16-09=1: Trip inverter when keypad is removed while operating in local mode.

| | |
|--------------|--|
| 16-10 | RTC Function Selection |
| Range | 【0】 : Hide 【1】 : Show |
| 16-11 | RTC Set Date |
| Range | 【12.01.01 ~ 99.12.31】 |
| 16-12 | RTC Set Time |
| Range | 【00:00 ~ 23:59】 |

Set the internal clock before using the function of Real Time Clock (RTC).

RTC date setting is determined by parameter 16-11 and RTC time setting is determined by parameter 16-12.

RTC is displayed in the top of the keypad and refer to Fig.4.3.85 for the selection of RTC time display (16-10) is set to 1.

| | |
|----------|-----------|
| Monitor | 00:00 |
| Freq Ref | |
| 12-16 = | 000.00 Hz |
| 12-17 = | 000.00 Hz |
| 12-18 = | 0000.0A |

Figure 4.3.85 RTC Time Display (Example)

Notes:

- RTC is disabled if the keypad is removed from the inverter.
- The RTC continues to run regardless of the RTC function being displayed using parameter 16-10 (RTC Time Display Setting).

Users can apply the parameters 12-72 and 12-73 to monitor the specific RTC date and time.

The Real-time Clock has the following functions:

- Four times per day
- Four weeks
- Timer offset function (preset time)
- Timer enable via multi-function digital input
- Selection for constant time and speed
- Timer enabled multi-function digital output

| | |
|--------------|--|
| 16-13 | RTC Timer Function Selection |
| Range | 【0】 : Disable 【1】 : Enable 【2】 : Enable by DI |

| | |
|-------|---|
| 16-14 | P1 Start Time |
| 16-15 | P1 Stop Time |
| 16-18 | P2 Start Time |
| 16-19 | P2 Stop Time |
| 16-22 | P3 Start Time |
| 16-23 | P3 Stop Time |
| 16-26 | P4 Start Time |
| 16-27 | P4 Stop Time |
| Range | 【00:00 ~ 23:59】 |
| 16-16 | P1 Start Date |
| 16-17 | P1 Stop Date |
| 16-20 | P2 Start Date |
| 16-21 | P2 Stop Date |
| 16-24 | P3 Start Date |
| 16-25 | P3 Stop Date |
| 16-28 | P4 Start Date |
| 16-29 | P4 Stop Date |
| Range | 【1】 : Monday 【2】 : Tuesday 【3】 : Wednesday 【4】 : Thursday 【5】 : Friday 【6】 : Saturday 【7】 : Sunday |
| 16-30 | RTC Offset Selection |
| Range | 【0】 : Disable 【1】 : Enable 【2】 : Set by DI |
| 16-31 | RTC Offset Time Setting |
| Range | 【00:00 ~ 23:59】 |
| 16-32 | Source of Timer 1 |
| 16-33 | Source of Timer 2 |
| 16-34 | Source of Timer 3 |
| 16-35 | Source of Timer 4 |
| Range | 【0~31】 : Refer to Table 4.3.13 |
| 16-36 | Selection of RTC Speed |
| Range | 【0】 : Off 【1】 : By Timer 1 【2】 : By Timer 2 【3】 : By Timer 3 【4】 : By Timer 4 【5】 : By Timer 1+2 |

| 16-37 | Run Direction of RTC Speed |
|-------|--|
| Range | 【xxx0 B】 : RTC Run1 Forward Rotation 【xxx1 B】 : RTC Run1 Reverse Rotation 【xx0x B】 : RTC Run2 Forward Rotation 【xx1x B】 : RTC Run2 Reverse Rotation 【x0xx B】 : RTC Run3 Forward Rotation 【x1xx B】 : RTC Run3 Reverse Rotation 【0xxx B】 : RTC Run4 Forward Rotation 【1xxx B】 : RTC Run4 Reverse Rotation |

Source of timer can be selected to link multiple time periods and one time period can be set to multiple timers.

Timer is set by the following steps:

① **Start the timer:**

Timer starts via the setting of RTC timer function (16-13).

② **Set the time period:**

Set the start, stop time and date. If the start time is equal to the stop time the timer is disabled.

③ **Enable timer:**

Set time period for the specific timer (16-32~16-35).

④ **Link to parameters:**

The timer can be linked to the relay output. Only one relay output can be linked to one timer (e.g. 03-11, 03-12 and 03-39, 16-36).

Note: If the stop time is set to 12:00, Motor stops at from 12:01.

Refer to Fig.4.3.86 for RTC parameter structure.

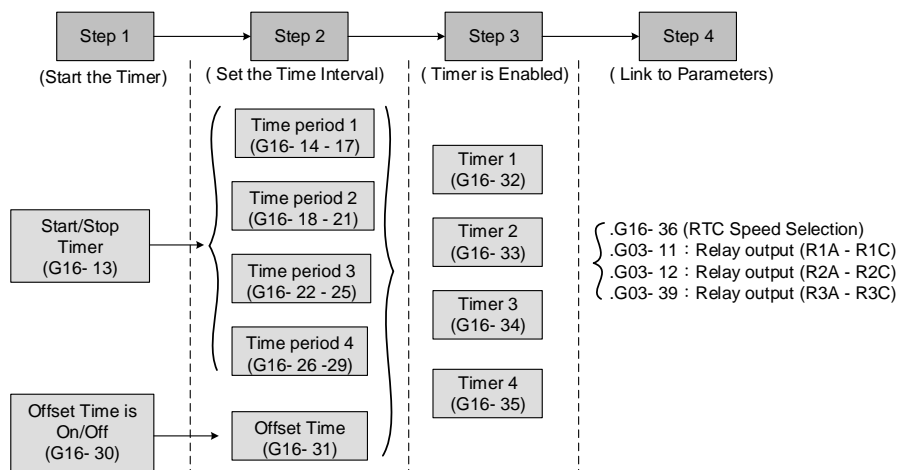

Figure 4.3.86 RTC structure

Refer to the following Table 4.3.13 for the selection of timer operation cycle.

Table 4.3.13 Set Time period for timer function

| 16-32 ~ 16-35 | O | P4 | P3 | P2 | P1 | Timer Function | Display |
|---------------------|---|----|----|----|----|--|---------------|
| 0 | 0 | 0 | 0 | 0 | 0 | Without the selection of timer | None |
| 1 | 0 | 0 | 0 | 0 | 1 | Time Period 1 | P1 |
| 2 | 0 | 0 | 0 | 1 | 0 | Time Period 2 | P2 |
| 3 | 0 | 0 | 0 | 1 | 1 | Time Period 1 and 2 | P1+P2 |
| 4 | 0 | 0 | 1 | 0 | 0 | Time Period 3 | P3 |
| 5 | 0 | 0 | 1 | 0 | 1 | Time Period 1 and 3 | P1+P3 |
| 6 | 0 | 0 | 1 | 1 | 0 | Time Period 2 and 3 | P2+P3 |
| 7 | 0 | 0 | 1 | 1 | 1 | Time Period 1 , 2 and 3 | P1+P2+P3 |
| 8 | 0 | 1 | 0 | 0 | 0 | Time Period 4 | P4 |
| 9 | 0 | 1 | 0 | 0 | 1 | Time Period 1 and 4 | P1+P4 |
| 10 | 0 | 1 | 0 | 1 | 0 | Time Period 2 and 4 | P2+P4 |
| 11 | 0 | 1 | 0 | 1 | 1 | Time Period 1 , 2 and 4 | P1+P2+P4 |
| 12 | 0 | 1 | 1 | 0 | 0 | Time Period 3 and 4 | P3+P4 |
| 13 | 0 | 1 | 1 | 0 | 1 | Time Period 1 , 3 and 4 | P1+P3+P4 |
| 14 | 0 | 1 | 1 | 1 | 0 | Time Period 2 , 3 and 4 | P2+P3+P4 |
| 15 | 0 | 1 | 1 | 1 | 1 | Time Period 1 , 2 , 3 and 4 | P1+P2+P3+P4 |
| 16 | 1 | 0 | 0 | 0 | 0 | Offset selection | Offset (O) |
| 17 | 1 | 0 | 0 | 0 | 1 | Offset and time period 1 | O+P1 |
| 18 | 1 | 0 | 0 | 1 | 0 | Offset and time period 2 | O+P2 |
| 19 | 1 | 0 | 0 | 1 | 1 | Offset and time period 1 and 2 | O+P1+P2 |
| 20 | 1 | 0 | 1 | 0 | 0 | Offset and time period 3 | O+P3 |
| 21 | 1 | 0 | 1 | 0 | 1 | Offset and time period 1 and 3 | O+P1+P3 |
| 22 | 1 | 0 | 1 | 1 | 0 | Offset and time period 2 and 3 | O+P2+P3 |
| 23 | 1 | 0 | 1 | 1 | 1 | Offset and time period 1 , 2 and 3 | O+P1+P2+P3 |
| 24 | 1 | 1 | 0 | 0 | 0 | Offset and time period 4 | O+P4 |
| 25 | 1 | 1 | 0 | 0 | 1 | Offset and time period 1 and 4 | O+P1+P4 |
| 26 | 1 | 1 | 0 | 1 | 0 | Offset and time period 2 and 4 | O+P2+P4 |
| 27 | 1 | 1 | 0 | 1 | 1 | Offset and time period 1 , 2 and 4 | O+P1+P2+P4 |
| 28 | 1 | 1 | 1 | 0 | 0 | Offset and time period 3 and 4 | O+P3+P4 |
| 29 | 1 | 1 | 1 | 0 | 1 | Offset and time period 1 , 3 and 4 | O+P1+P3+P4 |
| 30 | 1 | 1 | 1 | 1 | 0 | Offset and time period 2 , 3 and 4 | O+P2+P3+P4 |
| 31 | 1 | 1 | 1 | 1 | 1 | Offset and time period 1 , 2 , 3 and 4 | O+P1+P2+P3+P4 |

Reference frequency and motor rotation direction are controlled by RTC function.

16-36=0: RTC speed selection is disabled.

16-36=1: Timer 1 is enabled.

Reference frequency = Frequency Setting of Speed-Stage 0 (05-01)

16-36=2: Timer 2 is enabled.

Reference frequency = Frequency Setting of Speed-Stage 0 (05-01)

16-36=3: Timer 3 is enabled.

Reference frequency = Frequency Setting of Speed-Stage 0 (05-01)

16-36=4: Timer 4 is enabled.

Reference frequency = Frequency Setting of Speed-Stage 0 (05-01)

16-36=4: Timer 1 and 2 are enabled.

Frequency reference is controlled by the simultaneous operation of timer 1 and 2.

Notes:

- The inverter runs using the start of a specific timer without being affected by other timers.
- The RTC speed setting (16-36) is affected by timer period 1 to 4 (P1~P4) using RTC rotation direction (16-37).

Example:

When the selection of RTC speed is set to 5 (timer 1+2), source of run command (00-02) and source of frequency command (00-05) are required to be set to RTC to have the frequency reference be controlled by RTC timer 1 and 2.

Refer to Table 4.3.14 for more information.

Note: Selection of RTC Rotation Direction (16-37) depends on Motor Direction Lock Selection(11-00).

Table 4.3.14 Reference frequency is determined by timer 1 and 2

| Timer 1 | Timer 2 | Main Frequency Command Source Selection (00-05) | Source of frequency setting | Selection of rotation direction |
|---------|---------|---|---|---------------------------------|
| 0 | 0 | 6(RTC) | Set by frequency setting of speed-stage 0 (05-01) | By RTC 1 (16-37) |
| 1 | 0 | 6(RTC) | Set by frequency setting of speed-stage 1 (06-01) | By RTC 2 (16-37) |
| 0 | 1 | 6(RTC) | Set by frequency setting of speed-stage 2 (06-02) | By RTC 3 (16-37) |
| 1 | 1 | 6(RTC) | Set by frequency setting of speed-stage 3 (06-03) | By RTC 4 (16-37) |

RTC function is disabled when:

- Multi-function terminal (03-00~03-05) is set to fire mode.
- KEB function is enabled
 - Source of main frequency of RTC function is according to Table 4.3.14 and also can refer to main and alternative frequency command modes (00-07).
 - If main run command source selection (00-02) is set to 0~3 (0: keypad, 1: external terminal, 2: communication control, 3: PLC), refer to Table 4.3.15 for the relationship between main run command and RTC timer status.

Table 4.3.15 Relationship between main run command and RTC timer status

| Main run command 00-02 | RTC timer x status | Inverter status |
|------------------------|--------------------|---|
| 0~3 | 0 | Inverter cannot run (without run command) |
| 0~3 | 1 | Inverter cannot run (without run command) |
| 4 | 0 | Inverter cannot run (RTC timer is disabled) |
| 4 | 1 | Inverter runs and rotates depending on the function of 16-37. |

RTC timer example:

Inverter running on Monday between 6:00 AM to 10:00 PM.

Inverter running on Tuesday to Friday between 8:00 AM to 8:00 PM.

Inverter running on Saturday between 8:00 AM to 6:00 PM.

Inverter running on Sunday between 8:00 AM to 12:00 PM.

Motor running on weekdays (Mon. to Fri.) at speed 1 and on weekends at speed 2.

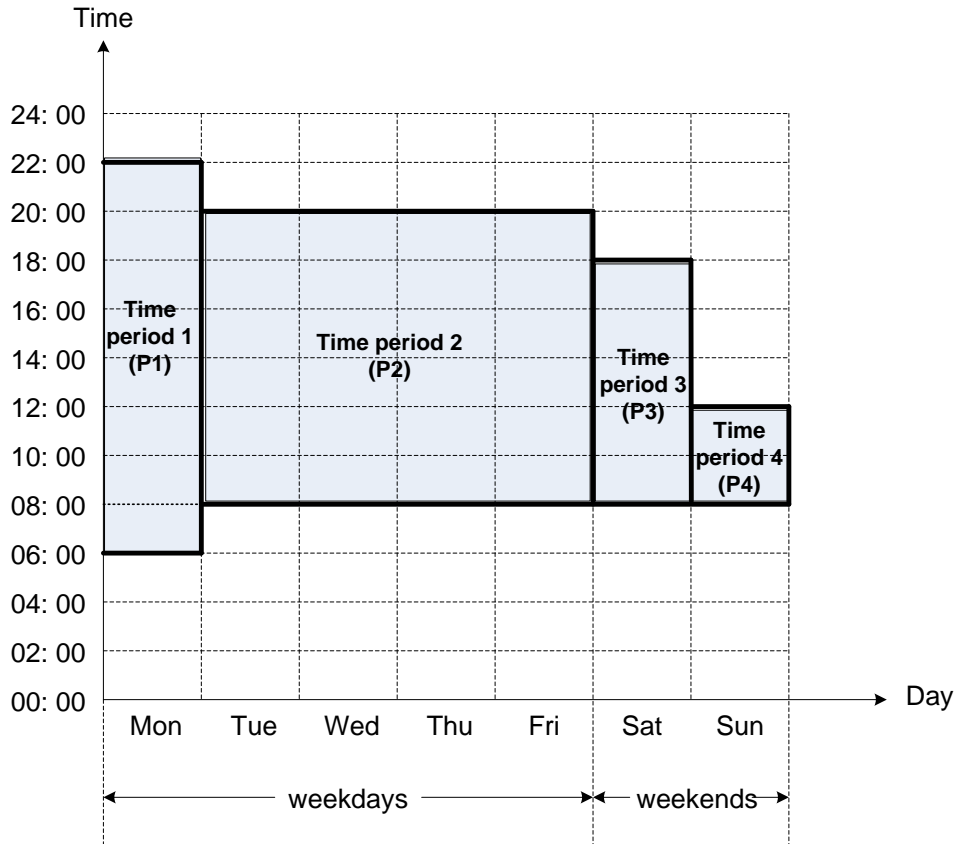

Figure 4.3.87 RTC timer (example)

- ① **Start up the timer in the parameter group 16** (Set the internal time first to enable this function).
Set the correct date and time in the parameters 16-11 and 16-12 and set parameter 16-13 to 1(enable RTC timer function).
- ② **Set time period 1 (P1)**
Start time 1: 16-14 = 06:00:00 (6:00 AM)
Stop time 1: 16-15 = 22:00:00 (10:00 PM)
Start date 1: 16-16 = 1 (Monday)
Stop date 1: 16-17 = 1 (Monday)
- ③ **Set time period 2 (P2)**
Start time 2: 16-18 = 08:00:00 (8:00 AM)
Stop time 2: 16-19 = 20:00:00 (8:00 PM)
Start date 2: 16-20 = 2 (Tuesday)
Stop date 2: 16-21 = 5 (Friday)
- ④ **Set time period 3 (P3)**
Start time 3: 16-22 = 08:00:00 (8:00 AM)
Stop time 3: 16-23 = 18:00:00 (6:00 PM)
Start date 3: 16-24 = 6 (Saturday)
Stop date 3: 16-25 = 6 (Saturday)
- ⑤ **Set time period 4 (P4)**
Start time 4: 16-26 = 08:00:00 (8:00 AM)
Stop time 4: 16-27 = 12:00:00 (12:00 AM)
Start date 4: 16-28 = 7 (Sunday)
Stop date 4: 16-29 = 7 (Sunday)
- ⑥ **Timer 1 is enabled to set all the time periods (P1, P2, P3, P4)**
16-32 = 15: Source of timer 1 = P1 + P2 + P3 + P4)
- ⑦ **Selection of RTC speed is determined by timer 1**
16-36 = 1: Timer 1 is enabled.
Frequency setting is speed-stage 0 (05-01).
Rotation direction (16-37) is set to 0000b.
Then, the rotation direction of time period 1~4 (P1~P4) is corresponding to the setting of 16-37.
- ⑧ **Choose two constant speeds (speed 1 & speed 2)**
16-36 = 5: Timer 1+2 is enabled.
When timer 1 is enabled, frequency setting is speed-stage 1; while timer 2 is enabled, frequency setting is speed-stage 2.
Rotation direction (16-37) is set to 0000b.
Then, when timer 1 and timer 2 are active, direction of motor rotation is forward rotation.

Note: Select RTC offset (16-30) and set RTC offset time (16-31) to enable the offset time. Inverter runs depending on the arranging time period to timer function. Refer to the following Fig.4.3.88.

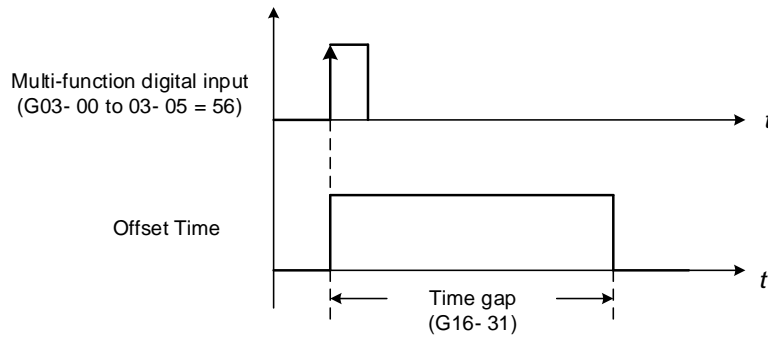

Figure 4.3.88 Operation of offset time

Example:

Inverter runs at the time period defined by P1:

When 16-36=1 (selection of RTC speed is set to timer 1) and 16-32=17 (offset + PI), RTC offset (16-30) is controlled by DI and the offset time is set via 16-31. Activate the DI and RTC will immediately turn on.

If the timer source is set to 15 (P1+P2+P3+P4), press “STOP” key at the time period 1 (P1). Normally the RTC will start automatically at the beginning of the next time period (P2) but it can be setup to start via a DI (16-30 = 2). The inverter and RTC start running again when activating the DI.

Notes:

If the “STOP” key is pressed within the time period the inverter can be re-started by:

- Setting the RTC offset selection (16-30) to 2 (set by DI) and set DI to 56 (RTC Offset Enable).
- Setting the RTC offset (16-30) to enabled.

Note:

RTC Accuracy:

| Temperature | Deviation |
|-------------------------|----------------|
| +25 °C (77 °F) | +/-3 sec./ day |
| -20 / +50°C (-4/ 122°F) | +/-6 sec./ day |

Group 17: IM Motor Automatic Tuning Parameters

| | |
|--------------|---|
| 17-00 | Mode Selection of Automatic Tuning |
| Range | 【0】 : Rotation Auto-Tune 【1】 : Static Auto-Tune 【2】 : R1 Tuning (Stator Resistance Measurement) 【4】 : Loop Adjust (Current Loop PID Adjustment) 【5】 : Rotation Auto-Tune (with Loop Adjust, Stator Resistance, and Rotation) 【6】 : Static Auto-Tuning (with Loop Adjust, Stator Resistance, and Static) |
| 17-01 | Motor Rated Output Power |
| Range | 【0.00~600.00】 KW |
| 17-02 | Motor Rated Current |
| Range | 10%~200% of the inverter rated current in V/F control mode 25%~200% of the inverter rated current in SLV control mode |
| 17-03 | Motor Rated Voltage^{*1} |
| Range | 【0.0~255.0】 V: 230V 【0.0~510.0】 V: 460V |
| 17-04 | Motor Rated Frequency^{*2} |
| Range | 【10.0~400.0】 Hz |
| 17-05 | Motor Rated Speed |
| Range | 【0~24000】 rpm |
| 17-06 | Pole Number of Motor |
| Range | 【2~16】 pole (Even) |
| 17-08 | Motor No-load Voltage |
| Range | 【50~240】 V: 220V 【100~480】 V: 440V |
| 17-09 | Motor Excitation Current |
| Range | 【0.01~600.00】 A (15%~70% motor rated current) |
| 17-10 | Automatic Tuning Start |
| Range | 【0】 : Disable 【1】 : Enable |
| 17-11 | Error History of Automatic Tuning |
| Range | 【0】 : No Error 【1】 : Motor Data Error 【2】 : Stator Resistance Tuning Error 【3】 : Leakage Induction Tuning Error 【4】 : Rotor Resistance Tuning Error 【5】 : Mutual Induction Tuning Error 【6】 : Reserved 【7】 : DT Error 【8】 : Motor Acceleration Error 【9】 : Warning |
| 17-12 | Leakage Inductance Ratio |
| Range | 【0.1~15.0】 % |
| 17-13 | Slip Frequency |
| Range | 【0.10~20.00】 Hz |

*1. Values of motor rated voltage are for 230V class, double the values for 460V class.

***2. The setting range of motor rated frequency is 0.0 to 400.0 Hz.**

Auto-tuning

Based on the motor nameplate set the motor rated output power (17-01), motor output rated current (17-02), motor rated voltage (17-03), motor rated frequency (17-04), motor rated speed (17-05) and number of motor poles (17-06) to perform an auto-tune.

■ Automatic tuning mode selection (17-00)

17-00=0: Perform rotational auto-tune (High performance auto-tune)

17-00=1: Perform a static non-rotational auto-tune

Motor does not rotate during auto-tuning and this tuning causes lower power at low speed.

17-00=2: Perform stator resistance non-rotational auto-tune (V/F mode) when using long motor leads.

This tuning causes lower power at low speed.

17-00=3: Reserved

17-00=4: Performance improvement (speed and torque regulation) in vector control mode

■ Motor rated output power (17-01)

Set by inverter capacity (13-00)

■ Motor rated current (17-02)

Set by inverter capacity (13-00)

Set the range to 10 %~200 % of the inverter rated current.

■ Motor rated voltage (17-03)

■ Motor rated frequency (17-04)

■ Motor rated speed (17-05)

When tuning a special motor (e.g. constant power motor, high-speed spindle motor), with a motor rated voltage or rated motor frequency that is lower than a standard AC motor, it is necessary to confirm the motor nameplate information or the motor test report.

Prevent the inverter output voltage from saturation when the motor rated voltage is higher than the inverter input voltage (see Example 1).

Example 1: Motor rated voltage (440V/60Hz) is higher than the inverter input voltage (380V/50 Hz).

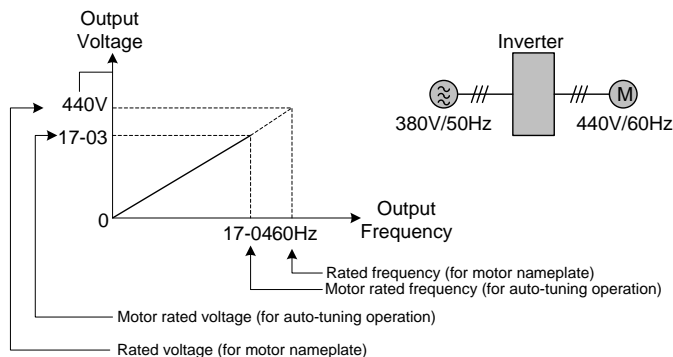

Figure 4.3.89 Rated voltage and frequency settings

Step 1: Set motor rated voltage, 17-03=440V.

Step 2: Set no-load voltage, 17-08=360V, lower the input voltage by 20V when operating in torque control.

Step 3: Set motor rated frequency:

$$17-04 = (\text{Rated frequency of motor nameplate}) \times \frac{(\text{Inverter input power voltage})}{(\text{Rated frequency of motor nameplate})} = 60\text{Hz} \times \frac{380\text{V}}{440\text{V}} = 51.8\text{Hz}$$

Step 4: Automatically tuning

Parameter 01-12 (Fbase) is automatically set during auto-tuning. Parameter 01-12 (Fbase) is set to the motor rated frequency.

Step 5: Set the 01-12 (Fbase) to the motor rated frequency on the motor nameplate. If the maximum output frequency (01-02, Fmax) and base frequency (01-12, Fbase) are different, set the maximum output frequency when the auto-tuning (01-02, Fmax) is completed.

When the inverter input voltage (or frequency) is higher than the motor rated voltage (or frequency), set the motor rated voltage (17-03) and the motor rated frequency (17-04) to the rated frequency on the motor nameplate.

Example 2: The inverter input voltage and frequency (440V/50Hz) are higher than the motor rated voltage and frequency (380V/33Hz), set 17-03 to 380V (rated motor voltage) and 17-04 to 33Hz (motor rated frequency).

- Number of poles (17-06)
Set the motor pole number with its range is 2, 4, 6, 8 and 16 poles.
- Motor no-load voltage (17-08)
 - a) Motor no-load voltage is mainly used in SLV mode, set to value 10~50V lower than the input voltage to ensure good torque performance at the motor rated frequency.
 - b) Set to 85 ~ 95% of the motor rated voltage. In general, the no-load voltage can be closer to the motor rated voltage for larger motors, but cannot exceed the motor rated voltage.
 - c) The motor no-load voltage can be set to a value greater than the actual input voltage. In this case the motor can only operate under relatively low frequency. If the motor operates at the rated frequency an over voltage condition may occur.
 - d) The higher the motor power the higher the no-load voltage is.
 - e) A smaller no-load voltage will reduce the no-load current.
 - f) When load is applied the magnetic flux is weakened and the motor current increases.
 - g) A higher no-load voltage results in a higher no-load current.
 - h) When load is applied the magnetic flux weakens and the motor current increases. Increasing the magnetic flux generates back EMF and results in poor torque control.
- Motor excitation current (17-09)
 - a) Only the static-type or stator resistance measurement auto-tuning (17-00=1 or 17-00=2) can be set. This data can be obtained by manual tuning. Normally, it does not require adjusting.
 - b) Motor excitation current is used for non-rotational auto-tuning.
 - c) The setting range of motor excitation current is 15%~70% of the motor rated current.
 - d) If this parameter is not set, the inverter calculates the motor related parameters.
- Automatic tuning start (17-10)
Set parameter 17-10 to 1 and press ENTER the inverter will display "Atrdy" for Auto-tune ready. Next, press

RUN key to start the auto-tune procedure. During auto-tuning the keypad will display "Atune" for Auto-tune in progress. When the motor is successfully tuned, the keypad shows "AtEnd".

■ Error history of automatic tuning (17-11)

If auto-tuning fails the keypad will display the AtErr" message and the auto-tune cause is shown in parameter 17-11. Refer to section 5 for troubleshooting and possible automatic tuning error causes.

Note: The motor tuning error history (17-11) shows the tuning result of the last auto-tune. No error is displayed when auto-tune is aborted or when the last auto-tune was successful.

■ Motor Leakage Inductance Ratio (17-12)

- a) Only stator resistance measurement auto-tuning (17-00=2) can be set. Data can be obtained by manual tuning. Normally, it does not require adjustment.
- b) Mainly used during non-rotational auto-tuning. The default setting is 3.4%. It is required to perform an auto tune to save the adjusted value into parameter 02-33.
- c) If this parameter is not set, the inverter automatically calculates the motor related parameters.

■ Motor Slip Frequency (17-13)

- a) Only stator resistance measurement auto-tuning (17-00=2) can be set. Data can be obtained by manual tuning. Normally, it does not require adjustment.
- b) Mainly used for non-rotational auto-tuning. The default setting is 1Hz. It is required to perform an auto tune to save the adjusted value into parameter 02-34.
- c) If this parameter is not set, the inverter automatically calculates the motor related parameters.

Notes:

- Perform the "Stator resistance measurement" (17-00=2) auto-tune if the inverter/motor leads are longer than 167ft (50m).
- For the best performance in vector control mode perform the rotary-type automatic tune (17-00=0) first (using short motor leads between the inverter and motor) and a "Stator resistance measurement" (17-00=2) next.
- If a rotary auto-tune (17-00=0) cannot be performed, manually enter the mutual induction (02-18), excitation current (02-09), core saturation compensation factor 1 - 3 (02-11 - 02-13).
- Perform the "Stator resistance measurement" (17-00=2) in V/F control when inverter/motor leads are longer than 167ft (50m).

Group 18: Slip Compensation Parameters

| | |
|--------------|---|
| 18-00 | Slip Compensation Gain at Low Speed |
| Range | 【0.00~2.50】 |
| 18-01 | Slip Compensation Gain at High Speed |
| Range | 【-1.00~1.00】 |
| 18-02 | Slip Compensation Limit |
| Range | 【0~250】 % |
| 18-03 | Slip Compensation Filter Time |
| Range | 【0.0~10.0】 sec |
| 18-04 | Regenerative Slip Compensation Selection |
| Range | 【0】 : Disable 【1】 : Enable |
| 18-05 | FOC Delay Time |
| Range | 【1~1000】 msec |
| 18-06 | FOC Gain |
| Range | 【0.00~2.00】 |

Slip compensation automatically adjusts the output frequency based on the motor load to improve the speed accuracy of the motor mainly in V/F mode.

The slip compensation function compensates for the motor slip to match the actual motor speed to the reference frequency.

Slip compensation adjustment in V/F mode

18-00: Slip compensation gain at low speed

The adjustment of slip compensation gain at low speed follows the below procedure:

1. Set the rated slip and the motor no-load current (02-00).
2. Set the slip compensation (18-00) to 1.0 (factory default setting is 0.0 in V / F control mode)
3. For the operation with a load attached, measure the speed and adjust the slip gain (18-00) accordingly (increase in steps of 0.1).
 - If the motor speed is lower than frequency reference, increase the value of 18-00.
 - If the motor speed is higher than frequency reference, decrease the value of 18-00.

When the output current is greater than the no-load current (02-00), the slip compensation is enabled and the output frequency increases from f1 to f2. Refer to Fig.4.3.90., the slip compensation value is calculated as follows:

$$\text{Slip compensation value} = \text{Motor rated sync induction rotation difference} \times \frac{[\text{Output current (12-08)} - \text{motor no-load current (02-00)}]}{[\text{Motor output rated current (02-01)} - \text{motor no-load current (02-00)}]}$$

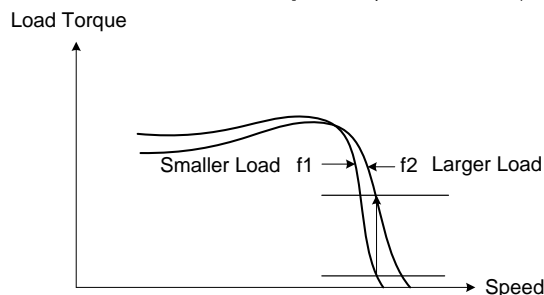

Figure 4.3.90 Slip compensation output frequency

18-02: Slip compensation limit

Sets slip compensation limit in constant torque and the constant power operation (Fig.4.3.91).
If 18-02 is 0%, the slip compensation limit is disabled.

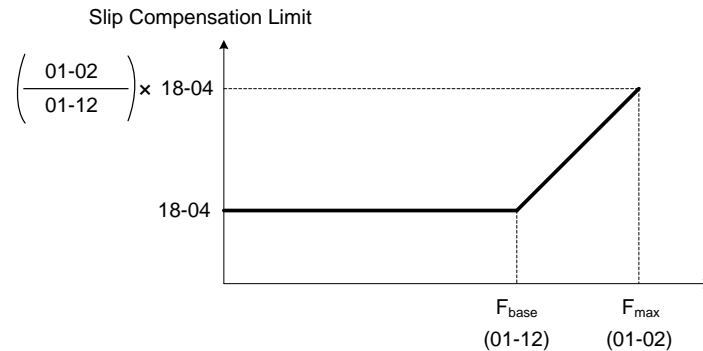

Figure 4.3.91 Slip compensation limit

When the slip compensation gain 18-00 at low speed is adjusted, and the actual motor speed is still lower than the reference frequency, the motor may be limited by the slip compensation limit.

Note: Make sure that the slip compensation limit 18-02 does not exceed the maximum allowed system limit.

18-03: Slip compensation filter

Set slip compensation filter time in V/F mode

18-04: Regenerating slip compensation selection

The selections to enable or disable the slip compensation function during regeneration.

To enable slip compensation during regeneration caused by deceleration (SLV mode), set 18-04 to 1 in case speed accuracy is required. When the slip compensation function is used regenerative energy might increase temporarily (18-04= 1) therefore a braking module might be required.

SLV mode adjustment

18-00: Slip compensation gain

- Slip compensation can be used to control the full rang speed accuracy under load condition.
- If the speed is lower than 2 Hz and the motor speed decreases, increase the value of 18-00.
- If the speed is lower than 2 Hz and the motor speed increases, reduce the value of 18-00.

Slip compensation gain uses a single value for the whole speed range. As a result the slip compensation accuracy at low speed is high but slight inaccuracies might occur at high speeds.

Adjust parameter 18-02 together with the compensation value or continue to adjust 18-00 if the speed accuracy at higher speed is not acceptable. Please note adjusting these parameters might impact the accuracy at lower speeds.

The impact of 18-00 on the torque and the speed are shown in Fig.4.3.92.

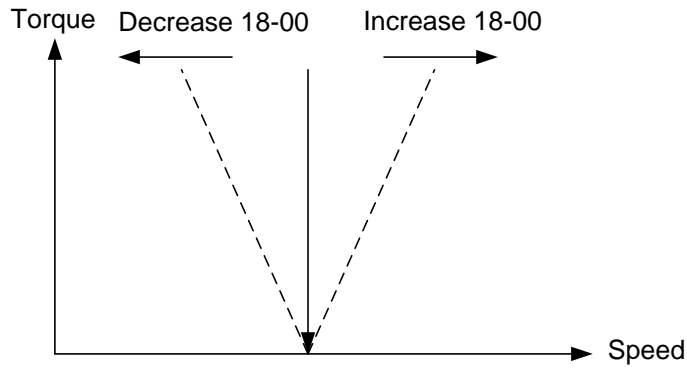

Figure 4.3.92 18-00 Effect on the torque and speed

18-01: Slip compensation gain at high speed

It is not required to adjust the Slip compensation gain at high speed if the motor is loaded. After adjusting parameter 18-00 it is recommended to increase the reference frequency and check the motor speed. In case of a speed error increase the value of 18-01 to adjust the compensation. Increase the motor rated frequency (01-12 base frequency) and increase the value of 18-01 to reduce the speed error. If the speed accuracy becomes worse due to an increase in motor temperature it is recommended to use a combination of 18-00 and 18-01 for adjustment.

Compared to 18-00, 18-01 serves as a variable gain for the full speed range. Parameter 18-01 determines the slip compensation at the motor rated speed and is calculated follows:

$$\text{Slip compensation gain} = \text{Slip compensation gain at low speed} + \frac{[\text{Slip compensation gain at high speed} \times \text{frequency reference}]}{[\text{Motor rated frequency}]}$$

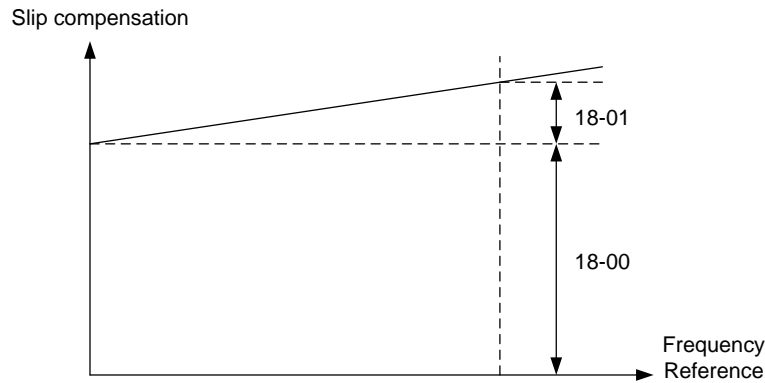

Figure 4.3.93 18-00/18-01 Slip compensation gain versus frequency reference

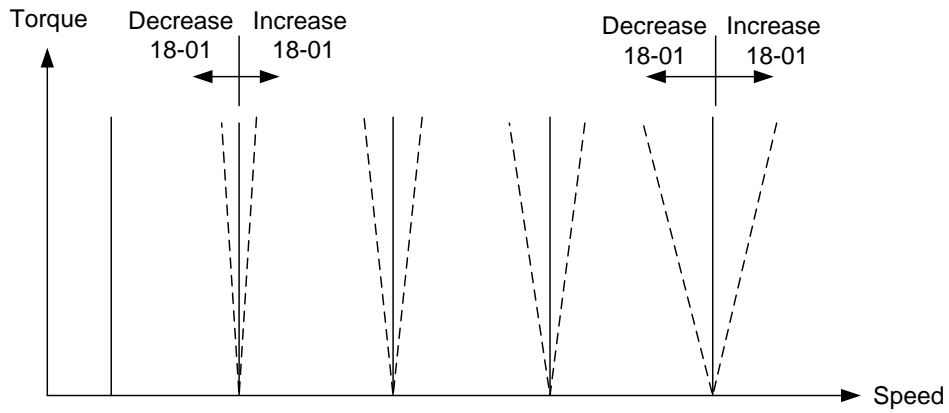

Figure 4.3.94 18-01 Effect on torque speed curve

18-05: FOC (Flux Orient Control) delay time

In the SLV mode, the slip compensation of the magnetic flux depends on the torque current and excitation current. If the motor load rises above 100% while running at the motor rated frequency, the motor voltage and resistance drops sharply, which may cause the inverter output to saturate and current jitter occur. The magnetic flux slip compensation will independently control the torque current and the excitation current to prevent increasing and decreasing of the current (jitter). For slow speed or fixed speed operation, 18-05 may be increased. For fast operation adjust 18-06.

18-06: Slip compensation gain

If the motor is jittering at the rated frequency under full load, the value of 18-06 may gradually be reduced to zero to reduce current jitter.

| | |
|--|--|
| Group 20 Speed Control Parameters | |
|--|--|

| | |
|--------------|---|
| 20-00 | ASR Gain 1 |
| Range | 【0.00~250.00】 |
| 20-01 | ASR Integral Time 1 |
| Range | 【0.001~10.000】 Sec |
| 20-02 | ASR Gain 2 |
| Range | 【0.00~250.00】 |
| 20-03 | ASR Integral Time 2 |
| Range | 【0.001~10.000】 Sec |
| 20-04 | ASR Integral Time Limit |
| Range | 【0~300】 % |
| 20-07 | Selection of Acceleration and Deceleration of P/PI |
| Range | 【0】: PI speed control will be enabled only in constant speed. For accel/decel, only use P control. 【1】 : Speed control is enabled either in constant speed or accel/decal. |
| 20-08 | ASR Delay Time |
| Range | 【0.000~0.500】 Sec |
| 20-09 | Speed Observer Proportional (P) Gain 1 |
| Range | 【0.00~2.55】 |
| 20-10 | Speed Observer Integral(I) Time 1 |
| Range | 【0.01~10.00】 Sec |
| 20-11 | Speed Observer Proportional (P) Gain 2 |
| Range | 【0.00~2.55】 |
| 20-12 | Speed Observer Integral(I) Time 2 |
| Range | 【0.01~10.00】 Sec |
| 20-13 | Low-pass Filter Time Constant of Speed Feedback 1 |
| Range | 【1~1000】 mSec |
| 20-14 | Low-pass Filter Time Constant of Speed Feedback 2 |
| Range | 【1~1000】 mSec |
| 20-15 | ASR Gain Change Frequency 1 |
| Range | 【0.0~400.0】 Hz |
| 20-16 | ASR Gain Change Frequency 2 |
| | 【0.0~400.0】 Hz |
| 20-17 | Torque Compensation Gain at Low Speed |
| Range | 【0.00~2.50】 |
| 20-18 | Torque Compensation Gain at High Speed |
| Range | 【-10~10】 % |
| 20-33 | Constant Speed Detection Level |
| Range | 【0.1~5.0】 % |

The following figure an overview of the automatic speed regulator (ASR) block.

SLV control mode:

The ASR function adjusts the output frequency to control the motor speed to minimize the difference between the frequency reference and actual motor speed.

The ASR controller in SLV mode uses a speed estimator to estimate the motor speed. In order to reduce speed feedback signal interference, a low-pass filter and speed feedback compensator can be enabled.

The ASR integrator output can be disabled or limited. The ASR output is passed through a low-pass filter.

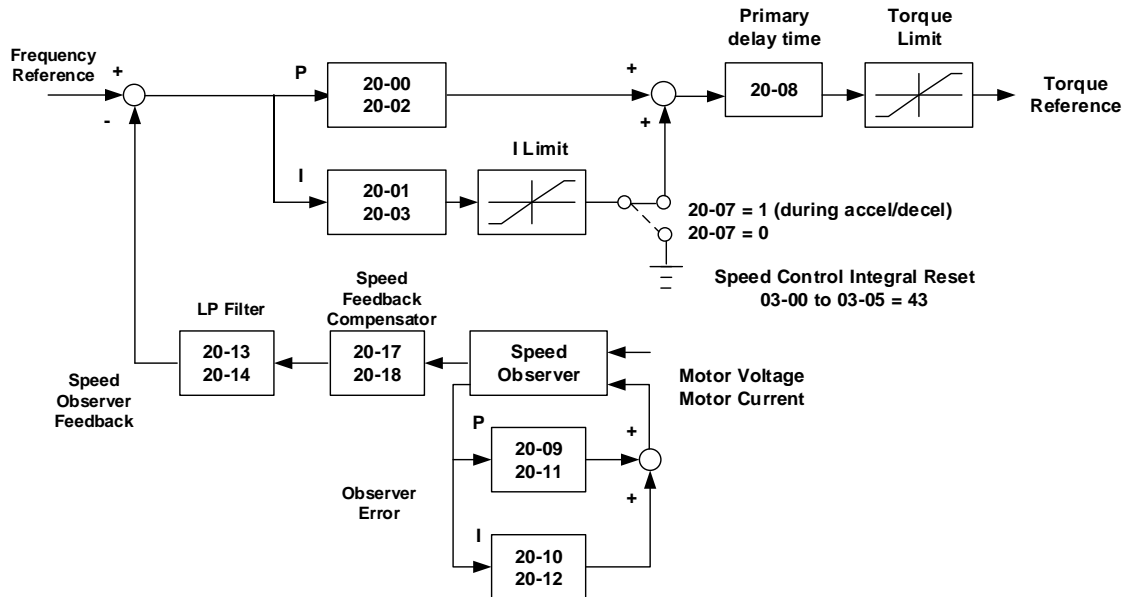

Figure 4.3.95 ASR block diagram (SLV mode)

ASR setting (SLV control mode)

In SLV mode the ASR gain is divided into a high-speed and low-speed section. The speed controller has a high-speed gain 20-00/20-01 and a low-speed gain 20-02/20-03 that can be set independently.

- The high/low switch frequency can be set with parameter 20-15 and 20-16. Similar to the ASR gain, the speed estimator has a high-speed gain 20-09/20-10 and a low-speed gain 20-11/20-12.
- The speed estimator has a low-pass filter to reduce the speed feedback interference, parameter 20-13 and 20-14 are active at high speed as well as low speed. The switch between the high-speed and the low-speed is set by parameter 20-15 and 20-16.
- 20-17 sets the low-speed compensation gain of the speed feedback.
- 20-18 sets the high-speed compensation gain of the speed feedback.
- When the frequency reference is rises above the value set in 20-16, the ASR gain used is set by parameters 20-00 and 20-01.
- When the frequency reference falls below the value set in 20-15, the ASR gain used is set by parameters 20-02 and 20-03.
- Gain time constant is adjusted linearly when the speed command falls within the range of 20-15 to 20-16, for a smooth operation.

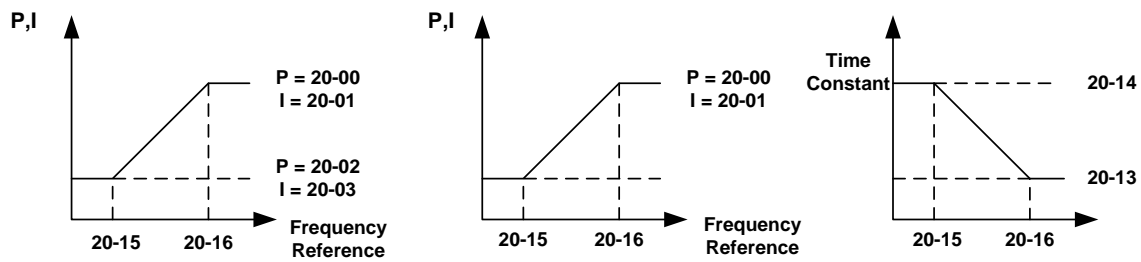

Figure 4.3.96 ASR gain setting (SLV mode)

Tuning the speed control gain

- a. Gain adjustment at minimum output frequency
 - Motor is running minimum output frequency (Fmin, 01-08).
 - Adjust the Maximum ASR proportional gain 2 (20-02) without causing instability.
 - Adjust the Minimum ASR integration time 2 (20-03) without causing instability.
 - Ensure the output current is lower than 50% of inverter rated current. If the output current is more than 50% of inverter rated current, decrease the setting value of parameter 20-02 and increase the value of 20-03.
- b. Gain adjustment at maximum output frequency
 - Motor is running at maximum output frequency (Fmax, 01-02).
 - Adjust the Maximum ASR proportional gain1 (20-00) without causing instability.
 - Adjust the Minimum ASR integration time 1 (20-02) without causing instability.
- c. Gain adjustment of accel./ decel. integral control
 - When 20-07=1, enabled for automatic speed regulation at constant speed and during acceleration / deceleration.
 - Integral control makes the motor speed react as possible reach to the target speed but may cause instability. Refer to Fig. 4.3.97 & Fig.4.3.98.

When 20-07=1, Enable ASR Proportion (P) and Integer (I) control during accel/ decel. / constant speed operation.

When 20-07=0, Enable ASR Proportion (P) and Integer (I) control only during constant speed operation and ASR P control during acceleration / deceleration.

Parameter 20-33 (Constant Speed Detection Level) is used to set a constant speed detection bandwidth active only when 20-07 is set 0 and frequency command source is set to analog input. Adjust the value of parameter 20-33 to compensate for noise during constant speed operation.

During ASR gain tuning, the multi-function analog output (AO1 and AO2 terminal) can be used to monitor the output frequency and motor speed (as shown in Fig.4.3.96).

SLV mode gain tuning (20-00~20-03, 20-09~20-18)

- a) Complete the parameter tuning in normal operation.
- b) Increase ASR proportional gain 1 (20-00), ASR proportional gain 2 (20-02), carefully monitor system stability.

Use parameter 20-00 and 20-02 to adjust the speed response for each cycle. Tuning the settings of 20-00, 20-02 can increase system response, but may cause system instability. See Fig.4.3.97.

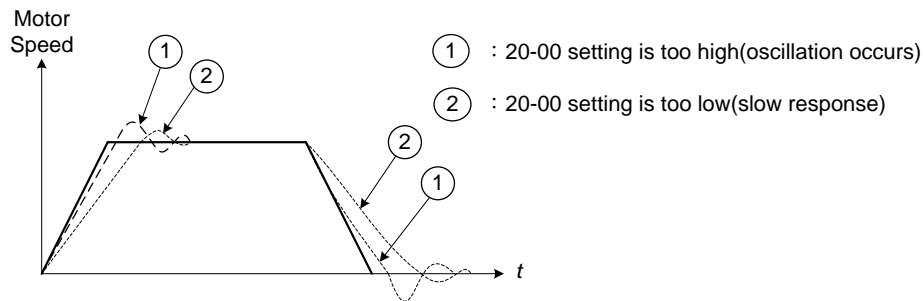

Figure 4.3.97 System response of ASR proportion gain

- a) Reduce ASR integral time 1(20-01), ASR integral time 2 (20-02) and carefully monitor system stability.
1. A long integral time will result in poor system response.
 2. If the integral time setting is too short, the system may become unstable Refer to the following figure.

While tuning ASR P and I gain the system may overshoot and an over voltage condition can occur. A braking unit (braking resistor) can be used to avoid an over voltage condition.

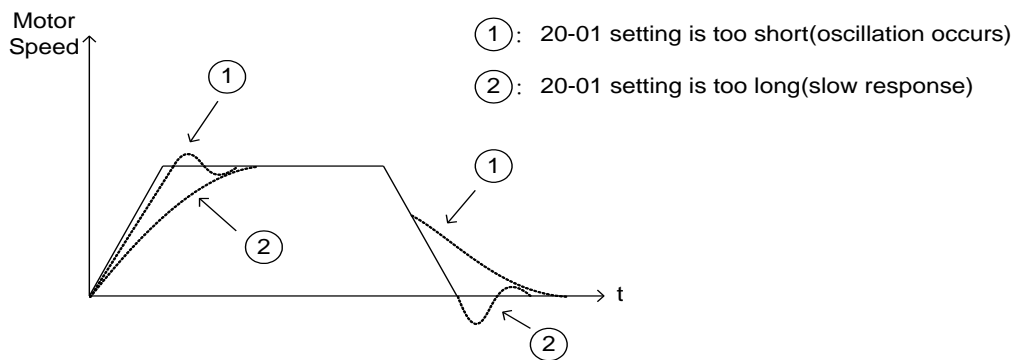

Figure 4.3.98 The response of ASR integral time

Both low-speed ASR gain and the high-speed gain can be set to the same values and only require to be adjusted in case of system instability.

In case tuning of the ASR P and I gain 20-00~20-03 does not improve the system response, reduce the low-pass filter time constant 20-13~20-14 to increase the bandwidth of the feedback system and re-tune the ASR gain.

- Tune low-speed low-pass filter time constant 20-14, make sure the reference frequency is below parameter 20-15 value.
- Tune high-speed low-pass filter time constant 20-13 at frequency reference, make sure the reference frequency is above parameter 20-16 value.
- Increasing the low-pass filter time constant can limit the bandwidth of the speed feedback system and may reduce the system response. Increasing the low-pass time reduces the speed feedback signal interference but may results in sluggish system response when the load suddenly changes. Adjust the low-pass filter time if the load stays fairly constant during normal operation. The low bandwidth of the speed feedback must be supported by the low gain of ASR to ensure the stable operation.
- Decreasing the low-pass filter time constant may increase the bandwidth of the speed feedback and the system response. Decreasing the low-pass time may increase the speed feedback interference resulting in system instability when the load suddenly changes. Decrease the low-pass filter time is a quick system response is required for rapidly changing loads. The high bandwidth of the speed feedback allows for a relative high ASR gain.

- In case tuning 20-00 ~ 20-03 and the low-pass filter time constant 20-13 do not improve the system response time, tuning the PI gain 20-09 ~ 20-12 of the speed estimator may be required.
- Setting a high gain for the speed estimator (high proportion (P) gain and small integral (I) time) increases the bandwidth of the speed feedback, but may cause speed feedback interference resulting in system instability.
- Setting a low gain for the speed estimator (small proportion (P) gain and high integral (I) time) decreases the bandwidth of the speed feedback, may improve speed feedback interference resulting in a more stable system.
- The default values for the ASR can be used in most applications, no adjustment is required. Adjusting the low-pass filter time and speed estimator gains requires a good understanding of the overall system.
- Parameter 20-15 sets the gain switch frequency at low-speed and parameter 20-16 sets the gain switch frequency at high-speed.
- Operating at a speed below 20-15 will result in a larger excitation current for low-speed operation accuracy. When the frequency reference rises above 20-16, the inverter will output the rated excitation current at the no-load voltage (02-19).
- For general purpose applications parameter 20-15 should be set to a value of 5 ~ 50% of the motor base frequency.
- If this value is too high, the inverter output may saturate. Parameter 20-16 should be set to a value of 4Hz or more above the value of 20-08.
- When experiencing speed jitter at high speed and stable operation during mid-range speed while operating a heavy load (>100%), it is recommended to reduce the no-load voltage (02-19) or tune the FOC parameters (18-05 ~ 18-06).
- Parameter 20-17 and 20-18 are for compensating speed feedback at low speed and high speed.
- Use parameter 20-17 to adjust the torque compensation gain for the low speed range. By tuning 20-17 an offset is added to the torque-speed curve. Increase 20-17 when the no-load speed is lower than the frequency reference. Decrease 20-17 when the no-load speed is higher than the frequency reference. The effect on the torque-speed curve from 20-17 is shown as the following figure:

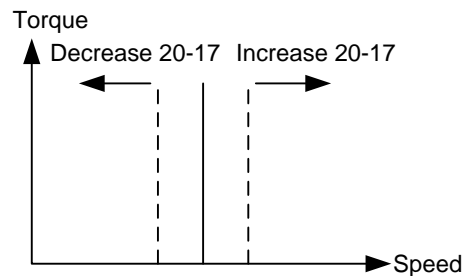

Figure 4.3.99 Effect on the torque-speed curve from 20-17

- Use parameter 20-18 to adjust the torque compensation gain for middle to high speed range. For most general purpose applications it is not necessary to adjust the 20-18. By tuning 20-18 an offset is added to the torque-speed curve. Increase 20-18 when the no-load speed is lower than the frequency reference. Decrease 20-18 when the no-load speed is higher than the frequency reference. The effect on the torque-speed curve from 20-18 is shown as the following Fig.4.3.100.

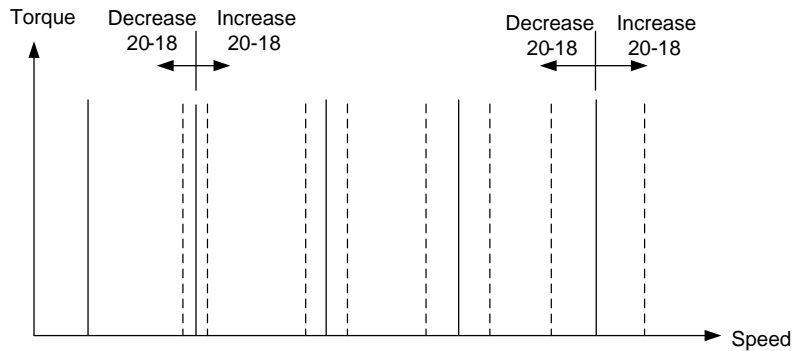

Figure 4.3.100 Effect on the torque-speed curve from 20-17

- ASR main delay time (20-08).
 - a) Does not required to be adjusted for general purpose applications
 - b) When the set value of 20-08 is set high, the speed response and therefore system response will decrease improving system stability.
- a. ASR Integral Time Limit (20-04)
 - a) Setting a small value may prevent system response when the load suddenly changes.

Note:

- Specification for no-load speed circuit bandwidth in vector control:
 1. 50 Hz is for control modes of SV / PMSV.
 2. 10 Hz is for control modes of SLV / PMSLV.
- Speed response is affected by k_p adjustment, inertia, load and motor temperature and the bandwidth will decrease slightly while controlling the application.

| | |
|--------------|--|
| 20-34 | Compensation Gain During Speed Drop |
| Range | 【0.00~25600】 |
| 20-35 | Compensation Time During Speed Drop |
| Range | 【0~30000】 mSec |

Decreasing the torque compensation value can reduce the response of the ASR during a momentary change in load. Refer to Fig. 4.3.97 & Fig. 4.3.98.

20-34 Compensation Gain During Speed Drop:

The effect of the Compensation Gain During Speed Drop is the same as the proportional gain of ASR (20-00, 20-02) but active only during the Compensation Time During Speed Drop (20-35) for large speed fluctuation to prevent the system instability.

20-35 Compensation Time During Speed Drop:

This time constant used to prevent system instability cause by parameter 20-34. Note increased compensation time can lead to a slower output response which is can affect derating compensation in negative way.

The recommended setting value of 20-34 is 30~50 and that of 20-35 is 50~100ms.

| | |
|---|--|
| Group 21 Torque Control Parameters | |
|---|--|

| | |
|--------------|---|
| 21-05 | Positive Torque Limit |
| Range | 【0~160】 % |
| 21-06 | Negative Torque Limit |
| Range | 【0~160】 % |
| 21-07 | Forward Regenerative Torque Limit |
| Range | 【0~160】 % |
| 21-08 | Reversal Regenerative Torque Limit |
| Range | 【0~160】 % |

Torque limit can be set in two ways:

- Use torque limit parameters (21-05 to 21-08) to set a fixed torque limit.
- Set the torque limit by using the multi-function analog input (AI2).

There are four torque limits that can be set separately, one for each quadrant:

- (I) Positive torque limit in forward direction (21-05 positive torque limit)
- (II) Positive torque limit of reverse direction (21-08 negative torque limit)
- (III) Negative torque limit in reverse direction (21-06 forward regenerating torque limit)
- (IV) Negative torque limit in forward direction (21-07 reversal regenerating torque limit)

Refer to Fig.4.3.101.

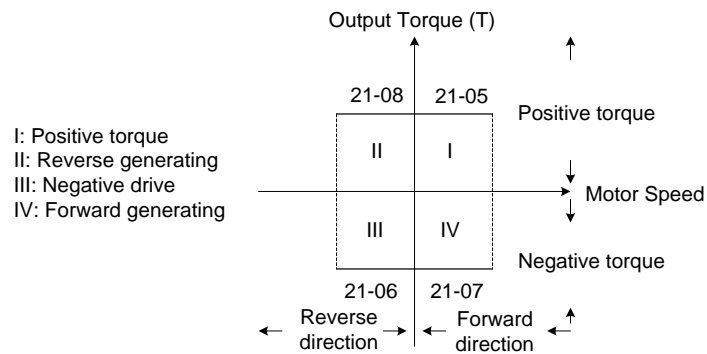

Figure 4.3.101 Torque limit setting

Torque limit setting by using multi-function analog input AI2 (04-05)

Table 4.3.16 Torque limit analog input

| 04-05 (AI2) | Function |
|-------------|--|
| 11 | Positive torque limit |
| 12 | Negative torque limit |
| 13 | Regenerative torque limit (for both forward and reversal directions). |
| 14 | Positive/negative torque limit (positive and negative detection torque limit) |

Set the analog input terminal (AI2) signal level (04-00), gain (04-07) and bias (04-08)

The default setting for the analog input AI2 is 0 -10V representing 0 – 100% of the motor rated torque).

Fig.4.3.102 shows the relationship between the output torque and the torque limit.

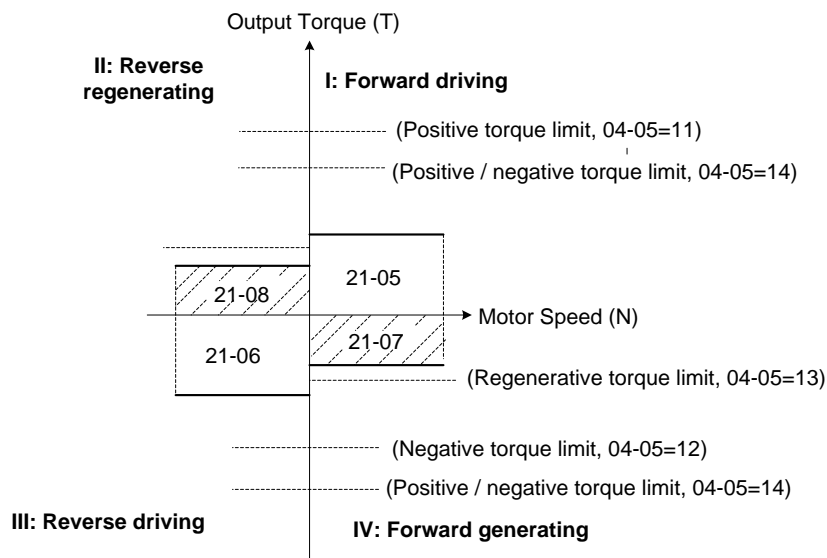

Figure 4.3.102 Analog input torque limit (AI2)

When the analog input is set to positive torque limit (value = 11) the torque limit is active in the third and fourth quadrant.in the reverse direction (regenerative torque in the second quadrant).

When the analog input is set to negative torque limit (value = 12) the torque limit is active in the third and fourth quadrant.

When the analog input is set to regenerative torque limit (value = 13) the torque limit is active in the second and fourth quadrant can be controlled.

When the analog input is set to positive/negative torque limit (value = 14) the torque limit is active in all four quadrants.

When the analog input is at maximum (10V or 20mA), the torque limit is 100% of the motor rated torque. In order to increase the torque limit above 100% the analog input gain (04-07) has to set to a value greater than 100%. For example: 160.0% of the gain will result in the torque limit of 160% of motor rated torque at 10V (20mA) analog input level.

| | |
|--|--|
| Group 22: PM Motor Parameters (PM Control Mode) | |
|--|--|

| | |
|--------------|---|
| 22-00 | Rated Power of PM Motor |
| Range | 【0.00~600.00】 Kw |
| 22-02 | Rated Current of PM Motor |
| Range | 25%~200% of inverter's rated current |
| 22-03 | Pole Number of PM Motor |
| Range | 【2~96】 Poles |
| 22-04 | Rated RPM of PM Motor |
| Range | 【1~60000】 rpm |
| 22-05 | Maximum RPM of PM Motor |
| Range | 【1~60000】 rpm |
| 22-06 | PM Motor Rated Frequency |
| Range | 【0.0~400.0】 Hz |
| 22-10 | PM SLV Start Current |
| Range | 【0.0 ~ 120.0】 % |
| 22-11 | DC Injection Current Level |
| Range | 【0.0 ~ 100.0】 % |
| 22-12 | Speed Observer kp Value |
| Range | 【1 ~ 10000】 |
| 22-13 | Speed Observer ki Value |
| Range | 【1 ~ 1024】 |
| 22-14 | PM Motor Stator Resistance |
| Range | 【0.001 ~ 30.000】 Ω |
| 22-15 | PM Motor D-axis Inductance |
| Range | 【0.01 ~ 300.00】 mH |
| 22-16 | PM Motor Q-axis Inductance |
| Range | 【0.01 ~ 300.00】 mH |
| 22-18 | Flux-Weakening Control |
| Range | 【0 ~ 100】 % |

The PM parameter group can be restored to factory default by initializing the inverter (13-08).

PM motor rated power (22-00)

Set the motor power according to the motor nameplate.

PM motor rated current (22-02)

Set the motor full load according to the motor nameplate.

PM motor pole number (22-03)

Set the number of motor poles according to the motor nameplate.

PM motor rated speed (22-04)

Set parameter 22-04 or 22-06, the inverter will automatically calculate one or the other.

Set the motor rated speed in rpm according to the motor nameplate.

Note:

Only set parameter 22-04 or 22-06, the inverter will automatically calculate the other one.

Formula: $n(22-04) = 120 * f(22-06) / P(22-03)$

PM motor maximum rotation speed (22-05)

Set the maximum motor rated speed in rpm according to the motor nameplate.

PM motor rated frequency (22-06)

Set the motor rated frequency according to the motor nameplate.

PM SLV Start Current (22-10)

Set the torque current at start up as % of motor rated current.

DC Injection Current (22-11)

Set the auto-tuning DC injection current of the permanent magnet (PM) motor as % of motor rated current.

Speed Estimation kp Value (22-12) & Speed Estimation ki Value (22-13)

Performance of speed response adjustment:

The higher the setting value is, the faster the motor response becomes; may result in instability of the motor load.

The lower the setting value is, the larger the speed deviation becomes. So, please adjust the proper setting value depending on the field apparatus.

PM Armature Resistance (22-14)

Set the motor resistance per phase in unit of 0.001Ω. This parameter is automatically set during motor auto-tuning (22-21).

Note: The motor resistance is different from the line resistance.

PM Motor D-axis Inductance (22-15)

Set motor D-axis inductance in unit of 0.01mH. This parameter is automatically set during motor auto-tuning (22-21).

PM Motor Q-axis Inductance (22-16)

Set motor Q-axis inductance in unit of 0.01mH. This parameter is automatically set during motor auto-tuning (22-21).

Flux-Weakening Control (22-18)

If motor maximum rotation speed (22-05) is greater than motor rated rotation speed (22-04), the inverter automatically uses flux-weakening control. Parameter value is maximum flux-weakening level in percentage of the motor rated current.

| | |
|--------------|--|
| 22-21 | PM Motor Tuning |
| Range | 【0】 : Disable 【1】 : Enable |
| 22-22 | Fault History of IPM Motor Tuning |
| Range | 【0】 : No Error 【5】 : Circuit tuning time out 【6】 : Reserved 【7】 : Other motor tuning errors 【8】 : Reserved 【9】 : Current Abnormity Occurs while Loop Adjustment 【10】 : Reserved 【11】 : Stator Resistance Measurement is Timeout 【12】 : Reserved |

SLV PM Motor Tuning (22-21)

WARNING!

Sudden start: The inverter and motor may start unexpectedly during Auto-Tuning, which could result in death or serious injury. Make sure the area surrounding of the motor and load are clear before proceeding with Auto-Tuning.

WARNING! Electric Shock Hazard

High voltage is applied to the motor when performing an auto-tune, even when the motor is stopped, which could result in death or serious injury. Do not touch the motor before performing the auto-tuning procedure is completed.

WARNING! Holding Brake

Do not perform an auto-tuning procedure when the motor is connected to a brake this may result in incorrect motor data calculation. Disconnect the motor and the load and confirm that the motor can freely run.

- a) Use parameter 22-21 to select tuning mode.
- b) Next press the enter key to go to the PM motor tuning screen. The keypad will display the message of "IPrdy" (Ready to Tune).
- c) Press run to start the PM motor tuning. The keypad will display the "IPtun" message during auto-tune.
- d) If the motor is successfully tuned, the message of "IPEnd " will be displayed. If auto-tune is aborted with the stop key, the operator will display the message of " IPbrd " (PM motor tuning aborted).

Fault History of SLV PM Motor Tuning (22-22)

Parameter 22-22 shows the PM motor tuning fault history. If PM motor tuning has failed, the "IPErr" message is shown on the keypad (PM motor tuning failure). Refer to section 10 for the possible error causes and trouble shooting.

PM motor tuning fault history (22-22) only stores the result of the last auto-tune performed .If auto-tuning was successful or aborted no error will be displayed.

Group 23: Pump & HVAC & Compressor Function Parameters

| 23-00 | Function Selection |
|-------|---|
| Range | 【0】 : Disable 【1】 : Pump 【2】 : HVAC 【3】 : Compressor |

Dedicated Pump and HVAC modes are available. To use these modes the PID function has to be enabled beforehand (10-03=xxx1b). Each application has their own parameter group these groups become available after the application settings is enabled. Parameters 23-01 to 23-39 are used for a Pump application; 23-45 to 23-58 are for HVAC and 23-66 to 23-70 are for a compressor application.

The main screen (16-00, 16-01, and 16-02) of LCD keypad automatically changes based on the application function selected as shown in the table below:

| | Pump mode 23-00=1 | HVAC mode 23-00=2 | Compressor 23-00=3 |
|-------|---------------------------|---------------------------|------------------------------|
| 16-00 | Pump setpoint 12-74 | HVAC setpoint 12-77 | Frequency reference 12-16 |
| 16-01 | Pump feedback 12-75 | HVAC feedback 12-71 | Output frequency 12-17 |
| 16-02 | Output frequency 12-17 | Output frequency 12-17 | Output current 12-18 |

Notes:

- Enable PID (10-03 = xxx1b) before using Pump and HVAC function
- Parameter 10-03 will automatically be set to xxx1b after 23-00 is set to 1 or 2; and will return to xxx0b when 23-00 is set 0.
- In Compressor mode, the frequency command, 00-05 is automatically set to 1 (refer to A11) and can't be set to 5 (PID). The middle output voltage (01-07) is automatically set to half of the maximum output voltage and parameter 01-00 will be hidden.

| 23-01 | Pump mode selection for single / multi pump system |
|-------|--|
| Range | 【0】 : Single Pump 【1】 : Master 【2】 : Follower 1 【3】 : Follower 2 【4】 : Follower 3 |

Parameter changes become active after restarting the drive. For wiring and parameter configuration please refer to chapter 3.3.4. Refer to fig. 4.3.111 for example of multi-pump application.

| | |
|--------------|--|
| 23-02 | Pump setpoint |
| Range | 【0.10 ~ 650.00】 PSI |
| 23-03 | Maximum Pressure Setting |
| Range | 【0.10 ~ 650.00】 PSI |
| 23-04 | Pump Setpoint Source |
| Range | 【0】 : From 23-02/12-74 【1】 : From AI1 |

The maximum pressure value depends on the pressure transducer used by the pump system. Parameter 23-02 is limited based on the maximum pressure setting (23-03). Pressure setpoint is selected by parameter 23-04.
Note: Refer to Appendix A for a detailed wiring of the system.

| | |
|--------------|--|
| 23-05 | Display Mode Selection (for LED keypad) |
| Range | 【0】 : Display Setpoint and Pressure Feedback 【1】 : Only Display Setpoint 【2】 : Only Display Feedback Pressure |

Both setpoint and feedback pressure can be displayed separately.

① When 23-05=0000: Led keypad displays pressure setting value and pressure feedback value.

20 10

The most left two digits is the setpoint value and the two right most digits is the pressure feedback value on the LED keypad.

Note: When 23-00=2 (HVAC), the value shown on the display is the actual divided by 10000. Example: Display value is 5.0 means 5000GPM.

② when 23-05=0001: Led keypad only displays the setpoint value.

20.0

③ when 23-05=0002: Led keypad only displays the pressure feedback value.

0 10

Note:

When the setpoint value is greater than 10, the setpoint value is displayed an “integer” number instead of a decimal number for 10-33 set to a value less than 1000 and 10-34=1 in PID mode.

| | |
|--------------|------------------------------|
| 23-06 | Proportion Gain (P) |
| Range | 【0.00~10.00】 |
| 23-07 | Integral Time (I) |
| Range | 【0.0~100.0】 Sec |
| 23-08 | Differential Time (D) |
| Range | 【0.0~100.0】 Sec |

- PID parameters can be changed while the inverter is running.

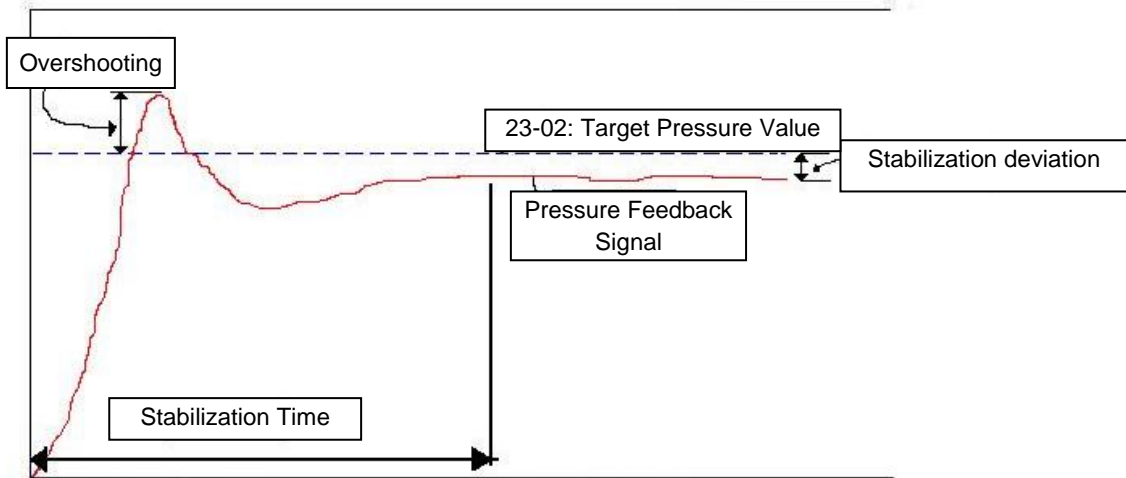

Figure 4.3.103 Response of pressure feedback signal

Table 4.3.17 PID parameter adjustment guidelines

| | | Increase Setting Value | Decrease Setting Value | Note |
|-----------------------|--------------|--|-----------------------------|----------------------------------|
| Proportional Gain (P) | Advantage | Improve response time | Reduce oscillation | Improve the settling time |
| | Disadvantage | Pressure may become unstable/oscillation | Slow down the response | |
| Integral Time (I) | Advantage | Improve the feedback variation | Fast response | Improve the stabilized deviation |
| | Disadvantage | Slow down response | System easily gets unstable | |
| Differential Time (D) | Advantage | Avoid overshoot | More stable | Improve the overshoot |
| | Disadvantage | System easily gets unstable | Large Overshoot | |

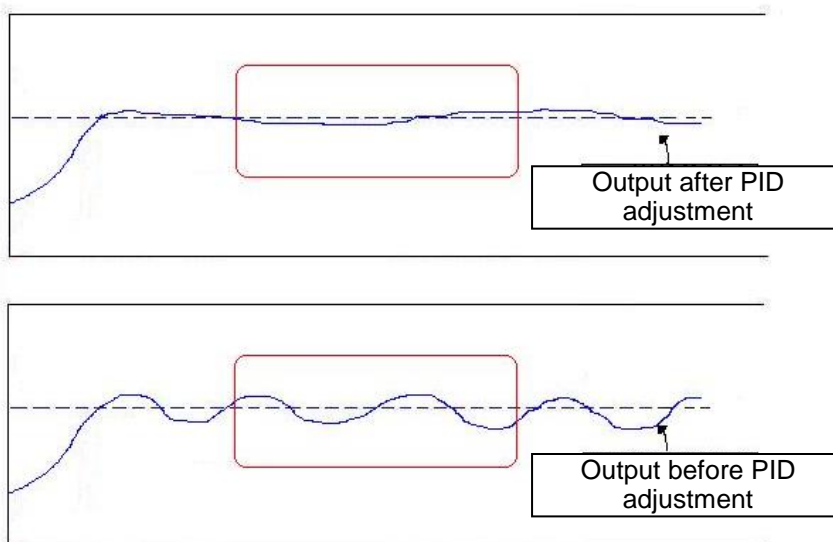

Figure 4.3.104 Response of feedback signal before/after PID adjustment

| | |
|--------------|--|
| 23-09 | Constant Pressure Detection Tolerance |
| Range | 【0.10~650.00】 PSI |
| 23-10 | Sleep Frequency of Constant Pressure |
| Range | 【0.0~180.0】 Hz |
| 23-11 | Sleep Time of Constant Pressure |
| Range | 【0.0~255.5】 Sec |

Inverter output frequency will decrease down to the sleep frequency when the pressure feedback value is greater than the Pump setpoint. Inverter output frequency increases when the pressure feedback value is smaller than (23-02) - (23-09).

The inverter will go to sleep (decelerate to zero) when the output frequency stays at the level defined by the Sleep Frequency of Constant Pressure (23-10) for the time specified by the Sleep Time of Constant Pressure (23-11).

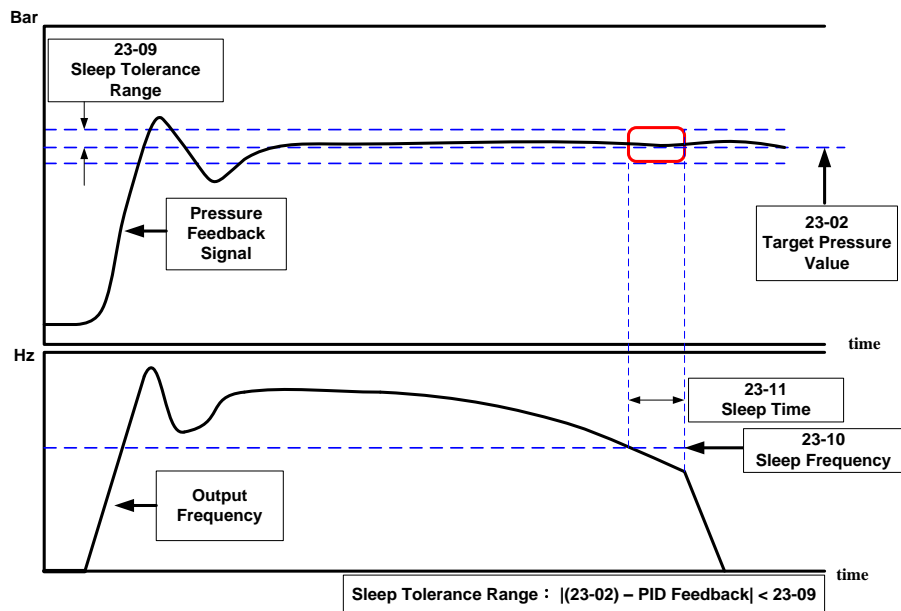

Figure 4.3.105 System response of constant pressure

| | |
|--------------|---------------------------------------|
| 23-12 | High Pressure Level |
| Range | 【0.10 ~ 650.00】 PSI |
| 23-13 | Warning Time for High Pressure |
| Range | 【0.1 ~ 255.0】 Sec |
| 23-14 | Fault Time for High Pressure |
| Range | 【0.1 ~ 255.0】 Sec |

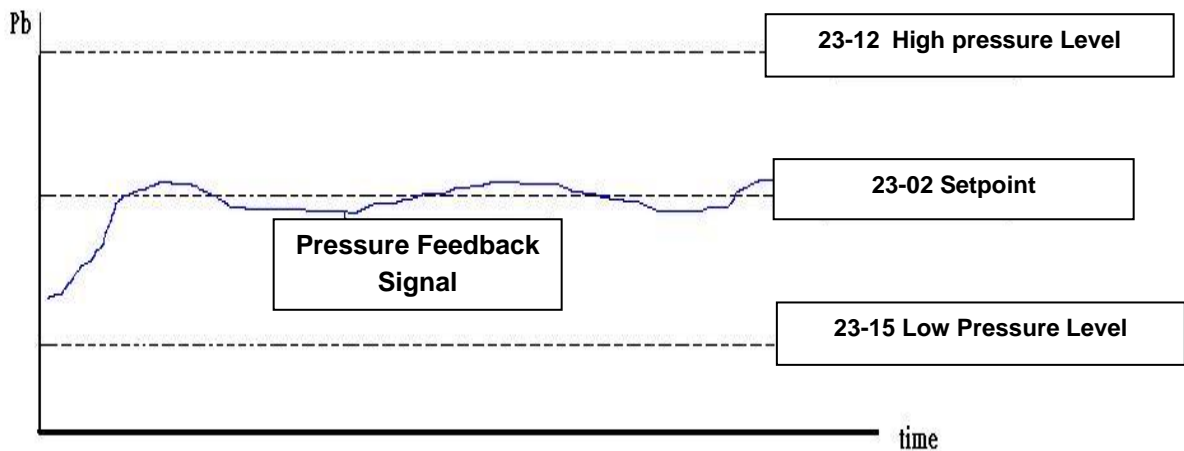

Figure 4.3.106 General situation for feedback signal

The inverter will trip on a High Pressure Fault (OPbFt) when the pressure feedback signal is greater than the High Pressure Level (23-12) for the time specified in Fault Time for High Pressure (23-14). A High Pressure warning (HIPb) is shown on the keypad when the High Pressure timer exceeds the time specified in Warning Time for High Pressure (23-13). The High Pressure Fault timer will reset when the pressure feedback falls below High Pressure Level (23-12) and start again from 0 when the feedback increases above the High Pressure Level (23-12).

Note: If 23-13=0, high-pressure protection function will be disabled.

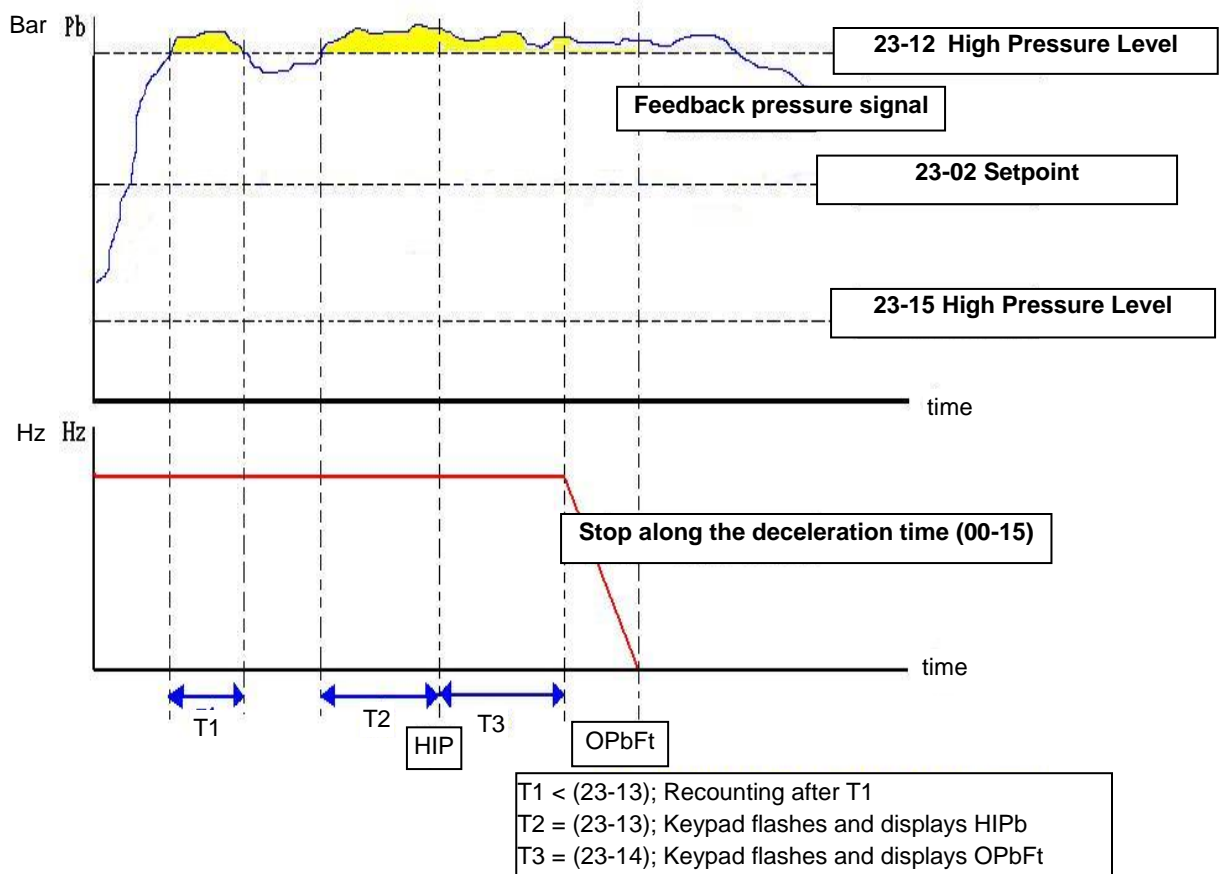

Figure 4.3.107 Process of warning and alarm when feedback higher than 23-12

| | |
|--------------|--------------------------------------|
| 23-15 | Low Pressure Level |
| Range | 【0.10 ~650.00】 PSI |
| 23-16 | Warning Time for Low Pressure |
| Range | 【0.1 ~ 255.0】 Sec |
| 23-17 | Fault Time for Low Pressure |
| Range | 【0.0 ~ 600.0】 Sec |

The inverter will trip on a Low Pressure Fault (LPbFt) when the pressure feedback signal falls below the Low Pressure Level (23-15) for the time specified in Fault Time for Low Pressure (23-17). A Low Pressure warning (LoPb) is shown on the keypad when the Low Pressure timer exceeds the time specified in Warning Time for Low Pressure (23-16). The Low Pressure Fault timer will reset when the pressure feedback rises above the Low Pressure Level (23-15) and start again from 0 when the feedback falls below the Low Pressure Level (23-15).

Note: If 23-16=0, low-pressure protection function will be disabled.

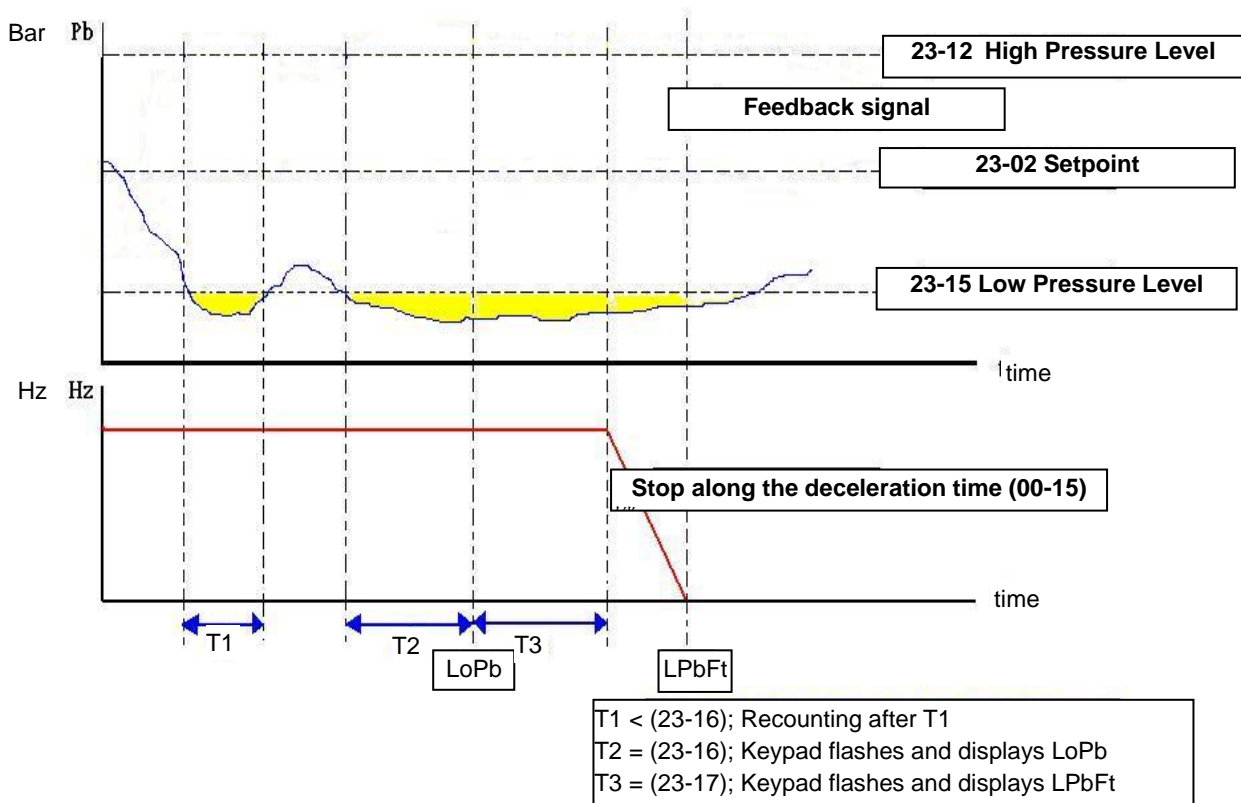

Figure 4.3.108 Process of warning and alarm when feedback lowers than 23-15.

| | |
|--------------|--|
| 23-18 | Detection Time of Pressure Loss |
| Range | 【0.0 ~ 600.0】 Sec |
| 23-19 | Pressure Loss Level |
| Range | 【0 ~ 100.0】 % |

23-19 = 0: Disable feedback pressure signal loss.

23-19 > 0: If the feedback pressure value falls below the value of **【(setpoint) x (23-19)】** for the time specified in detection time (23-18), the inverter faults on a FBLSS fault.

Note: This function is similar to the PID feedback loss, 10-11; Use function 10-11 if the inverter is required to keep running when feedback pressure is lost.

| | |
|--------------|--|
| 23-20 | Percentage of Pressure Level *1 |
| Range | 【0】 Pressure Unit 【1】 Percentage Unit |

***1: Available in firmware V1.1.**

23-20=0:

Engineering units for parameters 23-09, 23-12, 23-15, 23-24, 23-38 and 23-39 defined by 23-36.

23-20=1:

Engineering units for parameters 23-09, 23-12, 23-15, 23-24, 23-38 and 23-39 change to percentage (%). 100% scaling is equal to the maximum pressure setting (23-03). Example, 23-03=60 Psi, 23-12=80%, means that high pressure level is 48 PSI (60 x 0.8=48).

| | |
|--------------|--|
| 23-23 | Water Usage Detection function |
| Range | 【0】 : Upward Detection 【1】 : Downward Detection |
| 23-24 | Water Usage Detection Bias |
| Range | 【0.0 ~ 65.00】 PSI |
| 23-25 | Water Usage Detection Time |
| Range | 【0.0 ~ 200.0】 Sec |
| 23-26 | Acceleration Time of Water Usage Detection |
| Range | 【0.0 ~ 600.0】 Sec |
| 23-27 | Deceleration Time of Water Usage Detection |
| Range | 【0.0 ~ 600.0】 Sec |

Acceleration time of water usage detection (23-26) and deceleration time of water usage detection (23-27) use e acceleration time 2 (00-16) and the deceleration time 2 (00-17). Setting 23-26 changes the setting of 00-16 and 23-27 changes the value of 00-17. Do not use multi acc/dec function while pump application function is active.

23-25 = 0.0 (sec) disables the water usage detection function. The water usage detection function can be used to shorten the time it takes for the inverter to go sleep during limited or no water usage.

Extend the water detection time 23-25 when the water usage duty cycle increases, to avoid cycling in and out of sleep mode resulting in unstable system pressure.

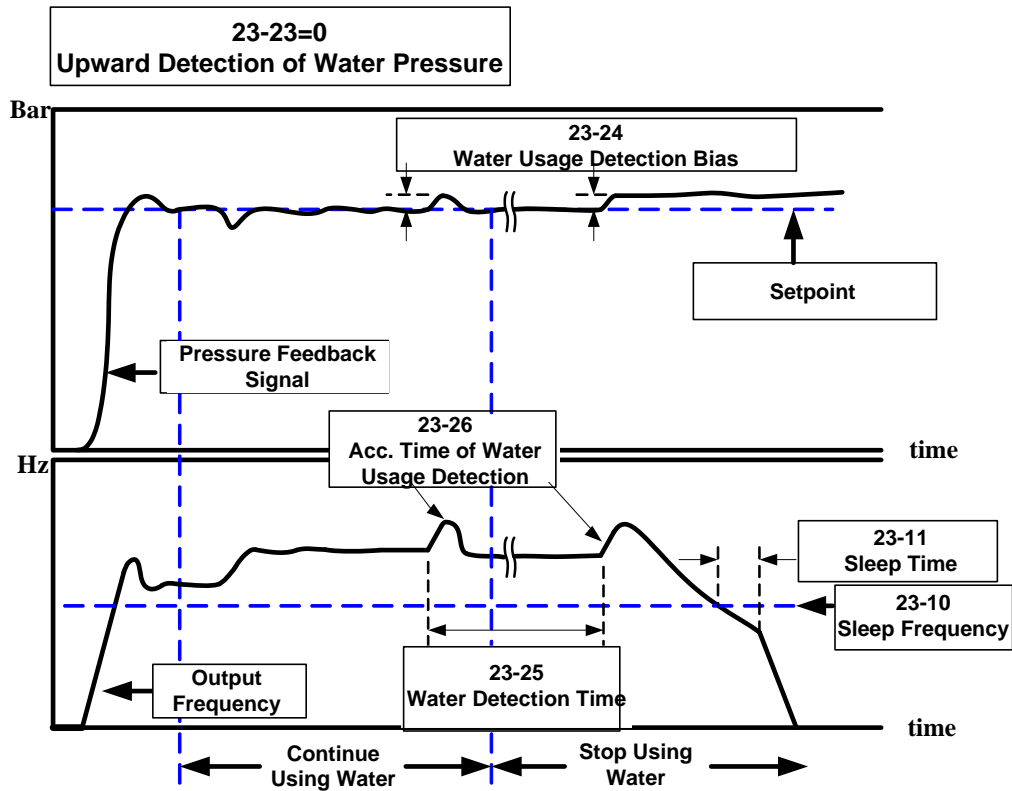

Figure 4.3.109 Process of upward detection of water pressure

For the water usage detection using upward detection mode, the output frequency is increased using the Acceleration Time of Water Usage Detection (23-26) until the pressure reaches a value of setpoint + 23-24.

The inverter will go to sleep if during the water usage detection cycle (23-25) the system pressure level stays above the setpoint; otherwise the PID function will decrease the output frequency (motor speed) to decrease the system pressure.

Reduce Water Usage Detection Bias (23-24) to reduce pressure instability during continued water usage. Please note that reducing the Water Usage Detection Bias (23-24) will extend the time it takes before the inverter detects a sleep condition when water usage is minimal or shutoff.

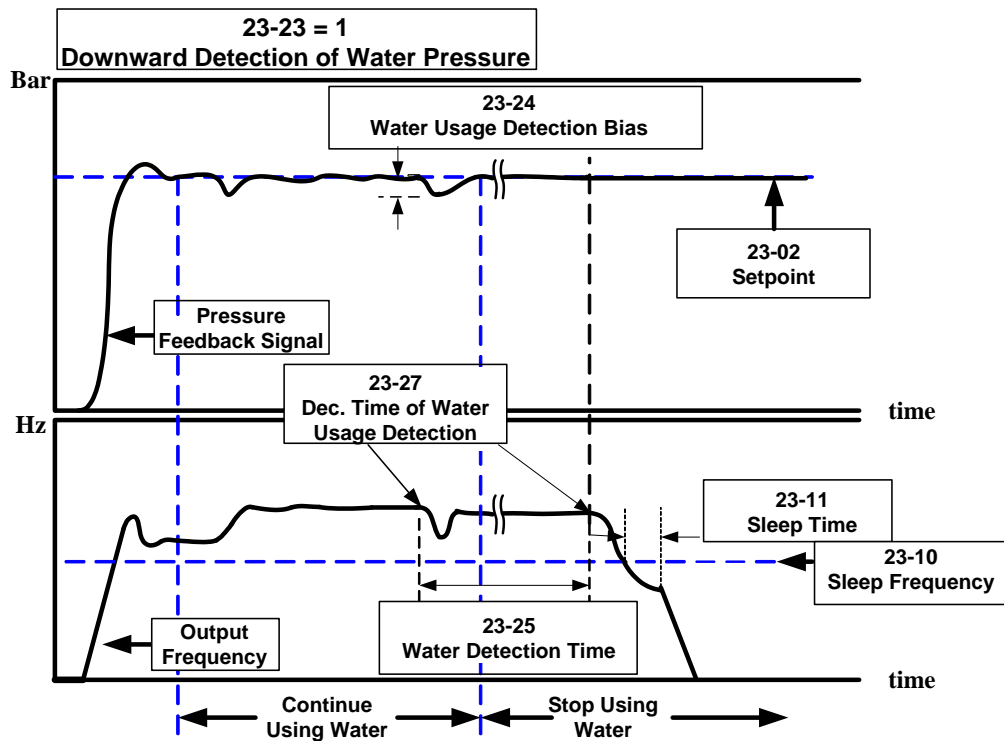

Figure 4.3.110 Process of downward detection of water pressure

For the water usage detection using downward detection mode, the output frequency is decreased using the Deceleration Time of Water Usage Detection (23-27) until the pressure reaches setpoint + 23-24.

The inverter will go to sleep if during this cycle (23-25) the system pressure is maintained; otherwise the PID function will increase the output frequency (motor speed) to increase the system pressure.

Increase 23-25 to improve system pressure oscillation caused by the water usage detection function.

Example: The system goes to sleep when it has a small leak and the pressure decreases during deceleration. For the inverter to re-accelerate depends on whether it reaches the sleep frequency first or if the pressure reaches the setpoint - 23-24 first.

Table 4.3.18 Guide for comparison of water pressure detection direction

| | Advantage | Disadvantage |
|---------------------------|---|--|
| Upward detection | <ul style="list-style-type: none"> Keep the pressure above the target pressure during this process. For strict and precise applications | <ul style="list-style-type: none"> Using standard sleep mode the system will hardly go to sleep when water is shut-off or only a small amount of water is used. In the multi-pump mode, followers hardly go into sleep mode. |
| Downward detection | <ul style="list-style-type: none"> Goes into sleep mode quickly in a situation where water is turned off or a small amount of water is used. In the multi-pump mode, regulate the pumps to provide optimum operation for the purpose of energy saving. In multi-pump mode, the order of startup is Master, Follower 1, Follower 2, and Follower 3. The process of going to sleep mode is to turn off Follower3, Follower 2, Follower 1 and the Master. After the switching time 23-29 expires the system alternates Master and Follower (lag pump) inverters to increase pump life expectancy. | <ul style="list-style-type: none"> Pressure fluctuations may occur during this process if user inappropriately regulates 23-24 and 23-27. |

| | |
|--------------|---------------------------------|
| 23-28 | Forced Frequency Command |
| Range | 【0.0 ~ 200.0】 Hz |

This function is available when PID mode (10-03) is enabled. Configure one of the multi-function digital inputs to be 16 (PID disable), and one set one to be 57 (forced frequency command). Turn ON the DI while PID is disabled, the inverter output frequency uses setting of 12-16; next turn-on the DI using the forced frequency command function, the frequency will follow the value set in 23-28.

This function is available in Pump, HVAC, and PID mode. It can be used to detect a pressure signal loss (disconnect) condition. **Note:** When the inverter operated in this mode it cannot be stopped by pressing the stop button.

| | |
|--------------|---|
| 23-29 | Time of Multi-Pump Switch Over |
| Range | 【0 ~ 240】 hour |
| 23-30 | Detection Time of Multi-Pump |
| Range | 【0.0 ~ 30.0】 Sec |
| 23-31 | Multi-Pump Synchronous Function |
| Range | 【0】 : Disable 【1】 : Pressure Setpoint and Run/ Stop 【2】 : Pressure Setpoint 【3】 : Run/Stop |

In multi-pump mode, the Master, Follower 1, Follower 2, and Follower 3 will automatically alternate to the next available one in sequence after all the drives have entered sleep mode for the time specified in 23-29.

When parameter 23-31 is set to 1 or 3, Detection Time of Multi-Pump (23-30) becomes active. If the system pressure is unable to meet the pressure setpoint - 23-09 within the time specified in 23-30, the Master will turn-on the next available follower (Lag pump).

23-31=0: Disabled.

23-31=1: Setpoint and Run/ Stop

Setpoint and Run/Stop command are modified and controlled by Master; Followers (Lag pumps) follow Master's command. Stop button on Followers (Lag Pumps) is still available, and can be used as an emergency stop.

23-31=2: Setpoint

Setpoint is modified / controlled by Master; Followers (Lag pumps) follow Master's setpoint.

23-31=3: Run/Stop

Run/ Stop command is controlled by Master, Followers (Lag pumps) follow Master's command. Stop button on Followers (Lag pump) is still available and can be used as an emergency stop.

Note: To change the setpoint on the Master requires pressing ENTER key to modify the pressure setting of all the followers (Lag pumps).

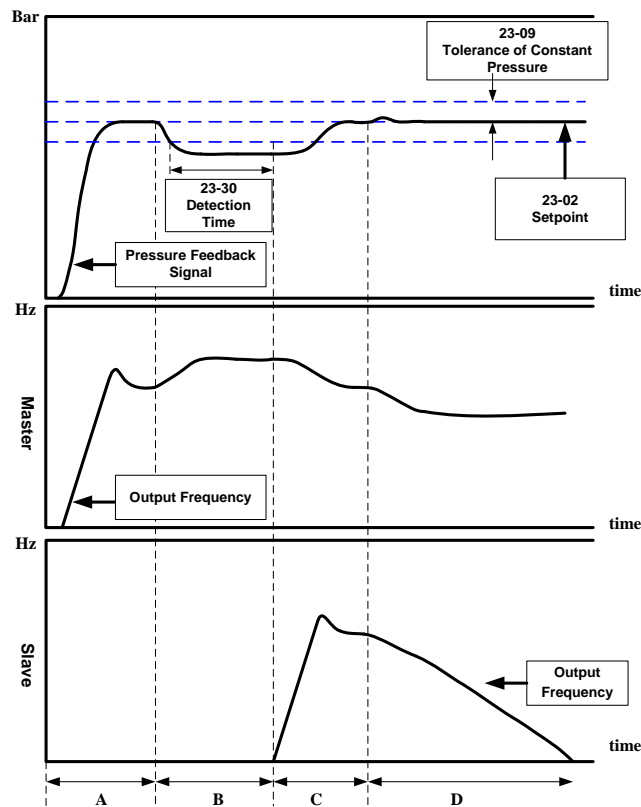

Figure 4.3.111 Dual pumps start up process

- A: Master start running first and follower (Lag pump) is waiting.
- B: The pressure drops, but the time specified in 23-30 has not yet expired, Follower (Lag pump) is waiting to come online.
- C: Master wakes up the next available Follower (Lag pump) to start running after the time specified in 23-30 has expired to increase the system pressure.
- D: The output frequency of both Master and Follower (Lag pump) decrease when pressure falls within the specified bandwidth (23-09). The Follower (Lag pump) will go into sleep before the master.

Notes:

- When both inverters are in sleep mode for the time specified in switching time (23-29), the master and Follower (Lag pump) will alternate.

- In multi-pump mode only one of the inverters can be set as the master (23-01 = 1).

| 23-36 | Pump Unit Selection |
|-------|---|
| Range | 【0】 : PSI 【1】 : inW 【3】 : Bar 【4】 : Pa |

Engineering unit for parameters 23-02, 23-09, 23-12, 23-15, 23-24, 23-38 and 23-39 are set by parameter (23-36).

| | |
|-------|---------------------------------|
| 23-37 | Leakage Detection Time |
| Range | 【0.0~100.0】 |
| 23-38 | Leakage Detection Variation |
| Range | 【0.01~65.00】 |
| 23-39 | Leakage Detection Wake up Level |
| Range | 【0.01~65.00】 |

Leakage Detection Case1: Pressure Variation > 23-38

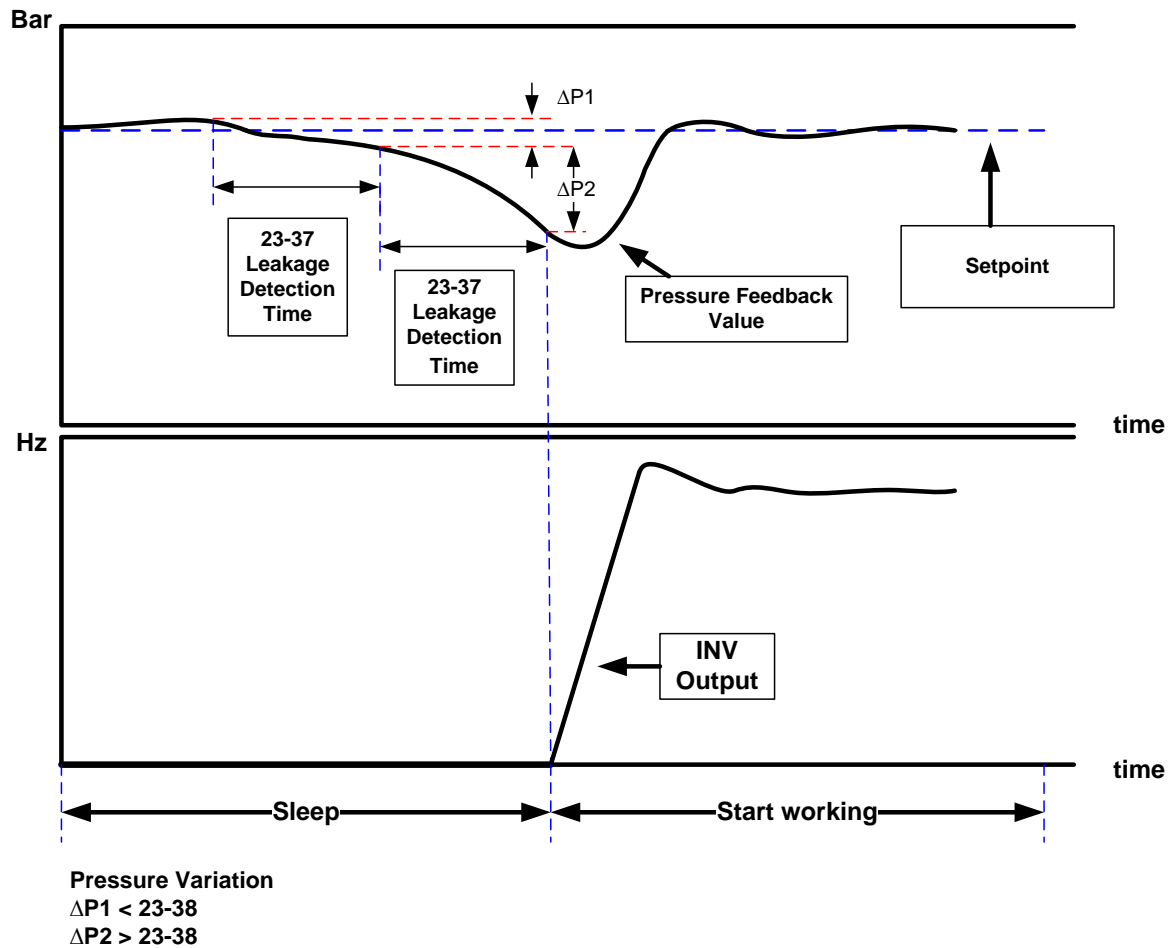

Notes:

- When 23-37 = 0.0 (sec), function is disabled.
- When the inverter is in sleep mode, pressure may drop over time due to a leak. The inverter will start when pressure variation is greater than the value set in parameter 23-38 for the time specified in 23-37.

- Leakage detection is available only in single pump mode.

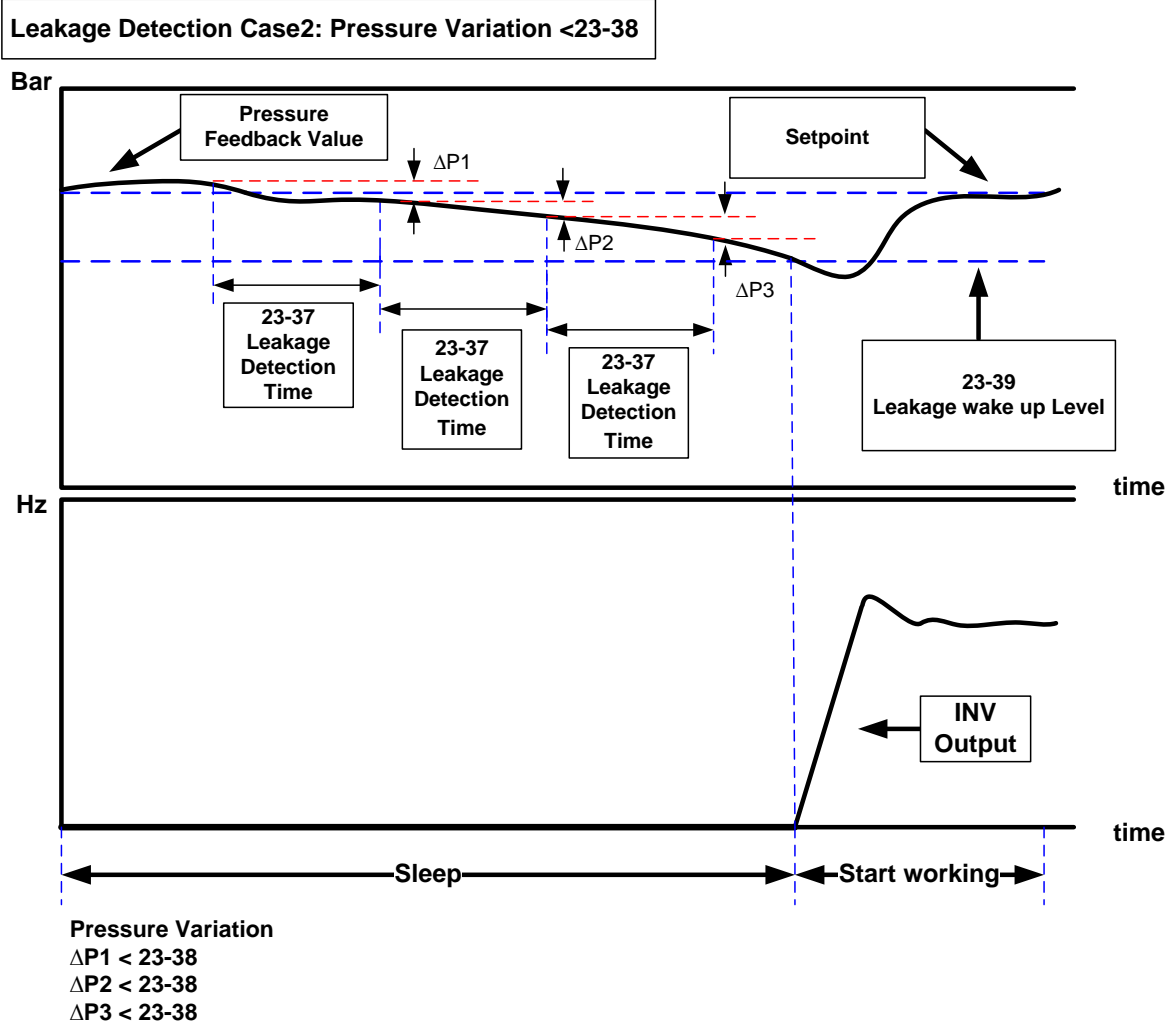

Notes:

- When 23-37 = 0.0 (sec), function is disabled.
- When the inverter is in sleep mode, pressure may drop over time due to a leak. The inverter will start when pressure drops below the value set in parameter 23-38 for the time specified in 23-37. The inverter starts if pressure variation is smaller than that of 23-38 or pressure falls outside the bandwidth specified by parameter 23-39 during the detection time.
- Properly adjust the leakage detection parameters 23-37, 23-38 and 23-39 to prevent system from cycling on and off caused by leak.
- Leakage detection is available only in single pump mode.

| | |
|--------------|---|
| 23-41 | Local/ Remote Key |
| Range | 【0】 : Disable 【1】 : Enable |

When enabled allows user to switch between local and remote operation.

Input source selection is determined by the source of frequency command (00-05) and the operation modes (00-02).

23-41=0: Disable

Frequency command is controlled by terminal AI1 and AI2 and run command is controlled by terminal S1, S2 or RS485. SEQ and REF lights are on.

23-41=1: Enable

User can use the FWD/REV key to switch between Local and Remote operation.

Frequency command is controlled by the keypad when SEQ and REF signal light are off.

Note: Local mode is controlled by the keypad and remote mode is controlled by control circuit terminals or RS485 connection.

| | |
|--------------|---|
| 23-42 | Energy Reset |
| Range | 【0】 : Disable (Energy Accumulating) 【1】 : Enable |
| 23-43 | Energy Price per KWH (\$ / kWh) |
| Range | 【0.000~5.000】 |
| 23-44 | Pulse Output Selection |
| Range | 【0】 : Disable 【1】 : Per 0.1kWh 【2】 : Per 1kWh 【3】 : Per 10kWh 【4】 : Per 100kWh 【5】 : Per 1000kWh |

When inverter starts up, user can view energy usage in parameter 12-67 (unit: kWh) and 12-68 (unit: MWhr). Reset energy usage by setting parameter 23-42 to 1.

Set the price per kWh in parameter 23-43 and view total cost in parameter 12-69 and 12-70.

The pulse output (23-44) can be set to output a pulse based on energy usage in kWh. The pulse output signal on condition lasts for 200ms independent of the selection in 23-44.

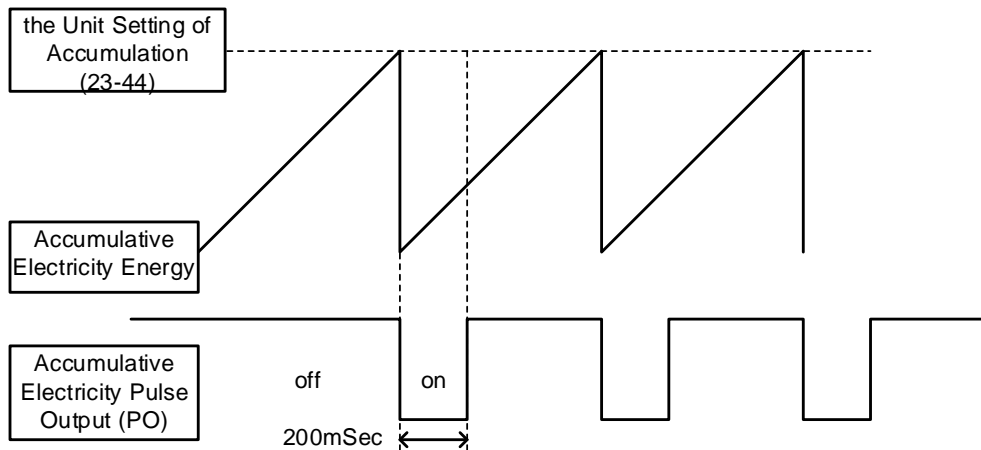

Figure 4.3.112 Accumulative electricity pulse output

| | |
|--------------|--|
| 23-45 | Flow Meter Type |
| Range | 【0】 : None 【1】 : Analog Input 【2】 : Pulse Train Input |
| 23-46 | Maximum rated Flow |
| Range | 【1~10000】 GPM |
| 23-47 | HVAC Setpoint |
| Range | 【1~10000】 GPM |
| 23-59 | HVAC Setpoint Source |
| Range | 【0】 : From 23-47/12-77 【1】 : From AI1 |

The value of maximum rated flow (23-46) depends on the flow meter used in the system. Parameter 23-47 range depends on the maximum flow rate set in parameter 23-46. The signal type of the flow meter is selected by 23-04.

Note: HVAC mode works when PID mode is enabled (10-03=xxx1b) and 23-00=2.

| | |
|--------------|-----------------------------------|
| 23-48 | Over Flow Level |
| Range | 【0.01~99.00】 % |
| 23-49 | Warning Time for Over Flow |
| Range | 【0~255】 Sec |
| 23-50 | Alarm Time for Over Flow |
| Range | 【0~255】 Sec |

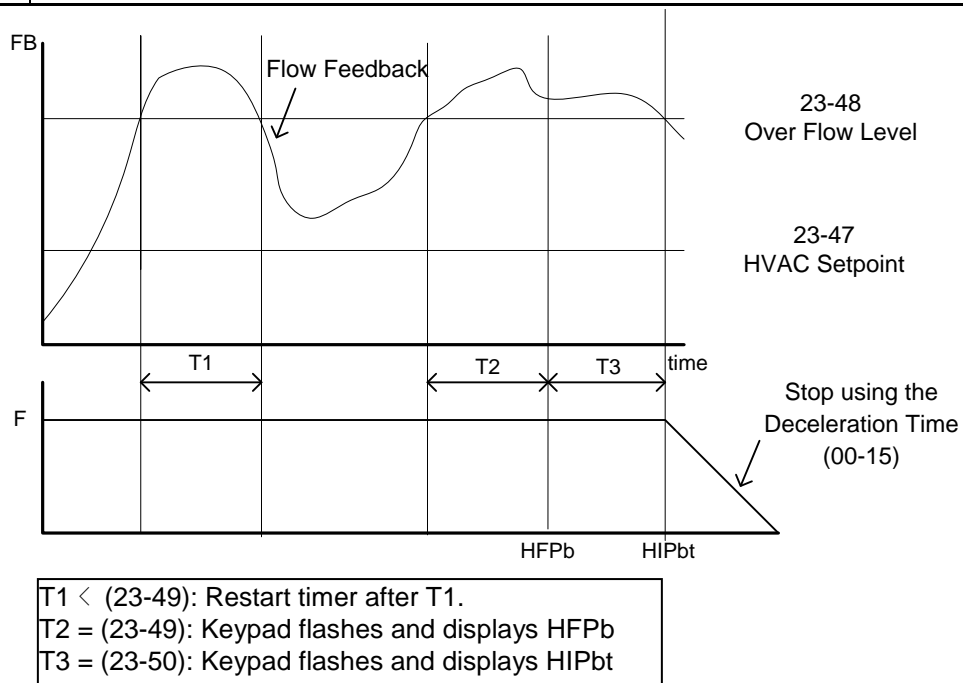
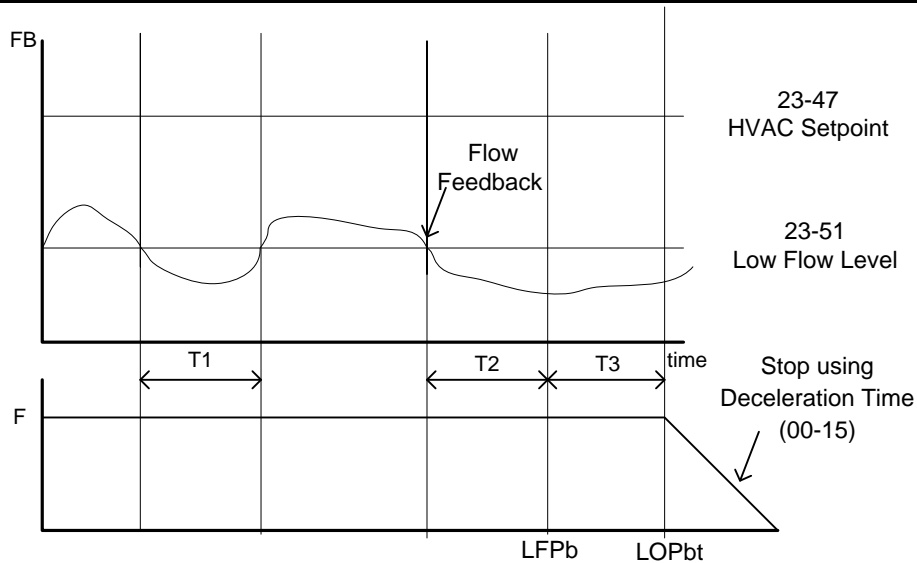

Figure 4.3.113 Over flow warning / stop

When flow level feedback is higher than the over flow level specified in parameter 23-48 for a time specified in 23-50 the inverter will trip on a HIPbt fault. The inverter displays a warning (HFPb) on the keypad when the flow level feedback is higher than the over flow level specified in parameter 23-48 for a time specified in 23-49. The internal timers for fault and alarm are reset to 0 when the flow level falls below the over flow level (23-48).

Note: Set parameter 23-50 to 0 to disable over flow protection.

| | |
|--------------|----------------------------------|
| 23-51 | Low Flow Level |
| Range | 【0.01~99.00】 % |
| 23-52 | Warning Time for Low Flow |
| Range | 【0~255】 Sec |
| 23-53 | Alarm Time for Low Flow |
| Range | 【0~255】 Sec |



| |
|---|
| <p>T1 < (23-52): Recounting after T1. T2 = (23-52): Keypad flashes and displays LFPb T3 = (23-53): Keypad flashes and displays LOPbt</p> |
|---|

Figure 4.3.114 Low flow warning / stop

When flow level feedback falls below the low flow level specified in parameter 23-51 for a time specified in 23-53 the inverter will trip on a LOPbt fault. The inverter displays a warning (LFPb) on the keypad when the flow level feedback falls below the low flow level specified in parameter 23-51 for a time specified in 23-52. The internal timers for fault and alarm are reset to 0 when the flow level rises above the low flow level (23-51).

Note: Set parameter 23-52 to 0 to disable over flow protection.

| | |
|--------------|--|
| 23-54 | Detection Function of Low Suction |
| Range | 【0】 : Disable 【1】 : PID Error 【2】 : Current 【3】 : PID Error and Current |
| 23-55 | Detection Time of Low Suction |
| Range | 【0~30.0】 Sec |
| 23-56 | PID Error Level of Low Suction |
| Range | 【0 ~ 30】 % |
| 23-57 | Current Level of Low Suction (Motor Rated Current) |
| Range | 【0 ~ 100】 % |
| 23-58 | Action of Low Suction |
| Range | 【0】 : Disable 【1】 : Warning 【2】 : Fault 【3】 : Fault & Restart |

Low suction detection can be used to detect for example a condition where there is insufficient water in the supply tank. Use parameter 23-58 to set the inverter action when a low suction condition is detected. Set low suction signal in parameter 23-54. Refer to Fig.4.3.115 for low suction block diagram.

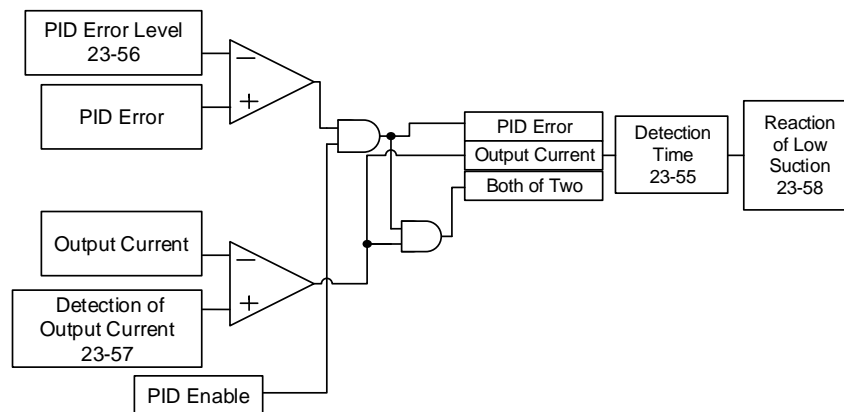

Figure 4.3.115 Function block of low suction protection

Table 4.3.19 the detection logic of low suction

| 23-54 | Detection Signal | |
|----------|------------------|----------------|
| | PID Error | Output Current |
| 1 | 1 | 0 |
| 2 | 0 | 1 |
| 3 | 1 | 1 |

- When 23-Detection Function of Low Suction is set to =1, (Detect PID Error), PID Error is used for low suction detection.
- When 23-54 Detection Function of Low Suction is set to =2, (Detect Current), output current is used for low suction detection.
- When 23-54 Detection Function of Low Suction is set to =3, both PID Error and Output Current are used for low suction detection.

Table 4.3.20 shows messages on the keypad during a low suction detection

Table 4.3.20 Detection signal of water used

| 23-58 | Inverter Status | Keypad Signal | Error Signal |
|-------|------------------|---------------|---|
| 0 | Running | None | None |
| 1 | Running | LSCFT(Flash) | Warning of Low Suction |
| 2 | Stop | LSCFT | Jump to Error for Low Suction |
| 3 | Stop and Restart | LSCFT | Jump to Error for Low Suction and Restart |

Note: Low suction state is detected if signal is higher than PID error level or lower than output current.

| 23-60 | HVAC Unit Selection |
|-------|--|
| Range | 【0】 : GPM 【1】 : FPM 【3】 : CFM 【4】 : GPH |

Engineering unit for parameters 12-7, 12-77, 23-46 and 23-47 is set by parameter 23-60.

| | |
|--------------|----------------------------------|
| 23-66 | Derating of Current Level |
| Range | 【10 ~ 200】 % |
| 23-67 | Derating Time |
| Range | 【1.0 ~ 20.0】 Sec |
| 23-68 | Derating Gain |
| Range | 【1~100】 % |
| 23-69 | OL4 Current Level |
| Range | 【10~200】 % |
| 23-70 | OL4 Delay Time |
| Range | 【0.0 ~ 20.0】 Sec |

In water-cooled chiller application operating the compressor at rated current for 1 to 2 minutes can easily cause damage to compressor, the inverter therefor incorporates a two- stage protection function to protect the compressor.

First Stage Protection:

When the inverter is at constant speed and the current is higher than the derating level (23-66) (percentage of rated current of the compressor), for the time specified in 23-67 the inverter will reduce the frequency reference command to reduce the current load. The new frequency reference is derating gain (23-68) x frequency reference. When the current falls below the derating of current level (23-66), output frequency will be restored to the original frequency reference. When the derating cycle repeats more than 3 times the output frequency will be set to the last known derating frequency until the current is falls below the derating level (23-66).

Example:

Set 23-66=80%, 23-67=10sec, 23-68=90%, frequency command is 60Hz and the rated current of compressor is 30A.

When the output current=27A, greater than 24A ($30A \times 80\%$), 10 sec (derating time) passes, and the output frequency decreases to 54 Hz (frequency command $60Hz \times 90\%$)

Next the output current decreases to 25A, but is still higher than 24A; another 10 sec passes, the adjust frequency reference now becomes 48.6 Hz ($60Hz \times 90\% \times 90\%$)

Next the output current decreases to 23A lower than 24A, therefor the output frequency is restored to 60Hz and the current rises back to 27A. When cycle repeat more than three times, the output frequency will stop at 48.6Hz and the output current decreases to 23A.

Protection of second stage:

When the current reaches the over load detection level (23-69) for the time specified in 23-70 the inverter will decelerate to a stop and display an OL4 fault (Compressor Overload).

Note: It is recommended that the rated current of compressor is required to be lower than that of inverter.

Group 24: Function of 1 to 8 Option Card

| 24-00 | Functional Selection of Relay Card |
|-------|--|
| Range | <p>【0】 : Disabled.</p> <p>【1】 : Fixed Modes of Inverter Pump: First on and Last off; then Stop All.</p> <p>【2】 : Fixed Modes of Inverter Pump: Only Stop Inverter Pump.</p> <p>【3】 : Fixed Modes of Inverter Pump: First on and First Off; then Stop All.</p> <p>【4】 : Cycle Modes of Inverter Pump: First on and First Off; then Stop All.</p> <p>【5】 : Cycle Modes of Inverter Pump: Only Stop Inverter Pump.</p> <p>【6】 : Cycle modes of Inverter Pump by built-in Relay: First on and First off; then Stop All.</p> |

The inverter with built-in PID controller in combination with a programmable logic controller (PLC) is commonly used in the pumping industry. The 1 to 8 pump option card can be used for constant pressure pumping systems without the need of an external controller. The inverter offers optimum pressure regulation using the built-in PID controller.

There are two basic operation modes for 1 to 8 relay card, and one mode using the relays on the inverter control board:

① Fixed modes of inverter pump:

In this mode, the inverter directly controls one pump; the other pumps are switched across the line and controlled by the inverter's 1 to 8 relay option card. Pumps 2 – 8 (Lag Pumps) are added when demand is required. See Fig 4.3.126 for the wiring diagram.

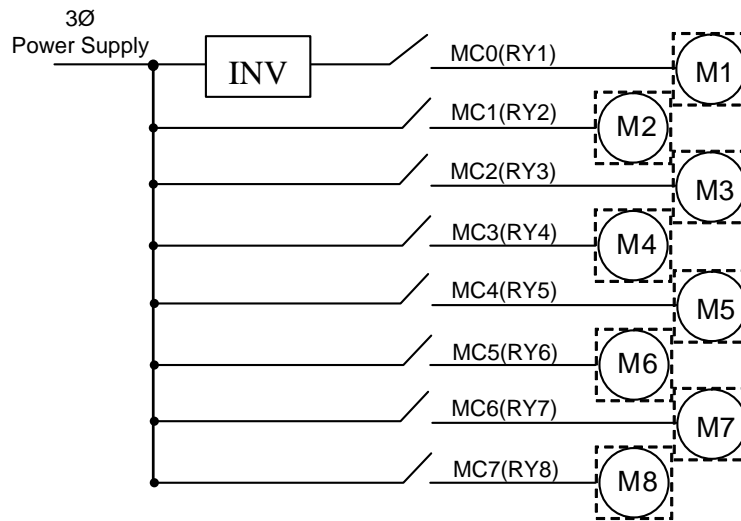

Figure 4.3.116 Fixed modes of inverter pump

② **Cycle modes of inverter pump:**

Up to 4 pumps are controlled sequentially by a single inverter. See fig 4.3.127 for the wiring diagram.

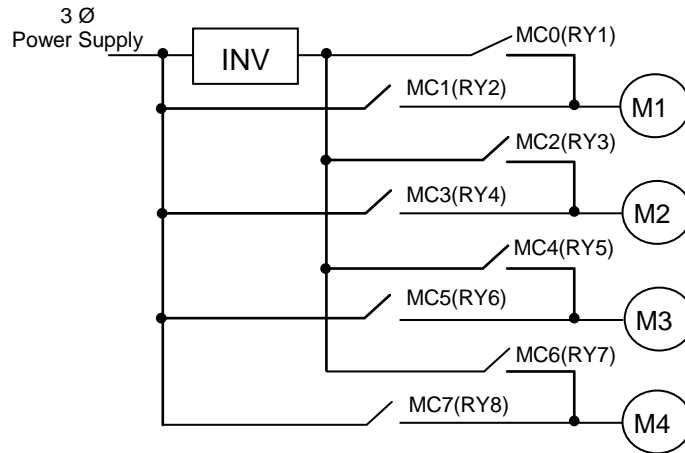

Figure 4.3.117 Cycle modes of inverter pump

③ **Cycle modes of inverter pump using built-in relays:**

Up to 3 pumps can be controlled using the three relays on the inverter control board to perform the cycle mode control without the need of the 1 to 8 relay card. See fig 4.3.128 for the wiring diagram.

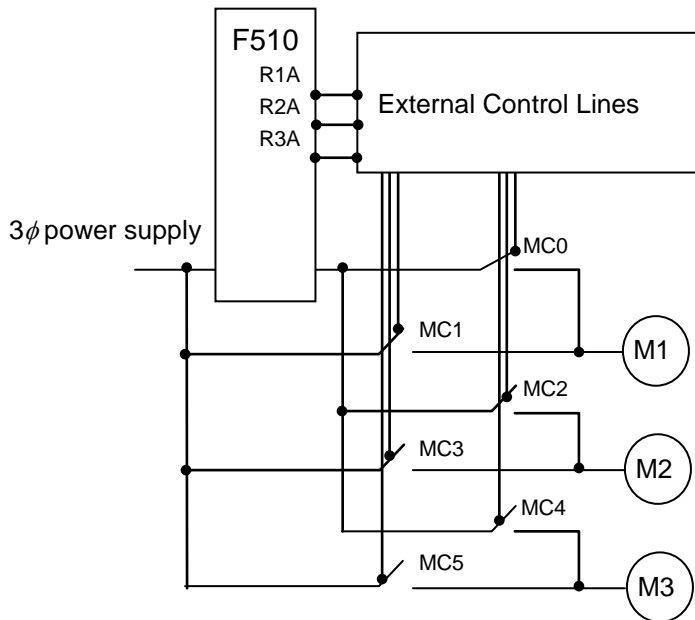

Figure 4.3.118 Cycle modes of inverter pump by built-in relay

24-00=0: 1 to 8 relay card is disabled.

24-00 = 1: Fixed modes of inverter pump, first on and last off; then stop all.

When the system pressure matches the setpoint for the time specified in 24-03, the auxiliary lag pumps turn off in order of first on last off. This mode can be used for motors with different ratings. See the timing chart in fig 4.3.120 and 4.3.121.

24-00=2: Fixed modes of inverter pump only stop inverter pump.

This mode works similar to mode 1, 24-00=1, except when inverter is stopped the auxiliary lag pumps that are running stay running (Relays stay ON).

24-00=3: Fixed modes of inverter pump, first on and first off; then stop all.

When the system pressure matches the setpoint for the time specified in 24-03, the auxiliary lag pumps turn off in order of first on first off. This mode can be used for motors with equal ratings.

24-00=4: Cycle modes of inverter pump, first on and first off; then stop all.

Motors are controlled by the inverter in sequence and turn off in order of first on first off. See the timing chart in fig 4.3.122 and 4.3.123.

24-00=5: Cycle modes of inverter pump, only stop the Inverter pump.

This mode works similar to mode 4, 24-00=4, except when inverter is stopped the auxiliary lag pumps that are running stay running (Relays stay ON).

24-00=6: Cycle modes of inverter pump by built-in relay: first on and first off; then stop all.

This mode is only active when 24-07=1, and works similar to mode 4, 24-00=4 except this mode uses the built-in relays on the inverter control card . See the timing chart in fig 4.3.124 and 4.3.125

Notes:

- If the 1 to 8 pump card is not installed, parameter 24-00 cannot be set (default 0).
- Set 24-07=1 first, before 24-00 can be changed even without installing the 1 to 8 pump card.
- PID function has to be enabled before performing group 24:
- PID function is enabled by setting parameter 10-03 PID control mode (10-03) to xxx1b (PID enable). Set PID setpoint source (10-00) to 4 and the setpoint in parameter 10-02. If the feedback signal source (10-01) is set to 2 (AI2) and the AI input signal type (04-00) is set to 0 (AI2: 0~10V) requires SW2 to be set to position V on the control board.
- PID disable (03-00~03-05 = 16) and Force Frequency Command (03-00~03-05 = 57) by DI are disabled when using function group 24.

| 24-01 | Selection of Relay 2-4 Function |
|-------|--|
| Range | 【xxx0b】 : Reserved 【xxx1b】 : Reserved 【xx0xb】 : Relay 2 Disable 【xx1xb】 : Relay 2 Enable 【x0xxb】 : Relay 3 Disable 【x1xxb】 : Relay 3 Enable 【0xxxb】 : Relay 4 Disable 【1xxxb】 : Relay 4 Enable |
| 24-02 | Selection of Relay 5-8 Function |
| Range | 【xxx0b】 : Relay 5 Disable 【xxx1b】 : Relay 5 Enable 【xx0xb】 : Relay 6 Disable 【xx1xb】 : Relay 6 Enable 【x0xxb】 : Relay 7 Disable 【x1xxb】 : Relay 7 Enable 【0xxxb】 : Relay 8 Disable 【1xxxb】 : Relay 8 Enable |

● **Fixed modes of inverter pump:**

In the fixed modes of inverter pump, RY1 is always used and RY2~RY8 can be used when required.

Inverter decelerates to the lower limit frequency (00-13*01-02) when relays switch ON, PID function is temporarily disabled until the frequency reaches the lower limit, and vice versa; inverter accelerates to upper limit frequency (00-12*01-02) when relays switch OFF, PID function is temporarily disabled until the frequency reaches the upper limit.

● **Cycle modes of inverter pump:**

In the cycle modes, two relays make a pair (RY1/RY2, RY3/RY4, RY5/RY6, RY7/RY8), up to 4 pairs. Both relays in one pair have to be enabled otherwise the relay pair does not work.

Inverter stops output, switches output to control the next motor and switches supply power to the previous motor (by turning ON relay, RY2, RY4, RY6 or RY8) when the pump system requires more pumps to maintain the pressure. When pressure is stable, then inverter keeps running and turns off the relays (pumps) as needed. Note: set switching time for magnetic contactor (24-05), time needed to switch motor from inverter to across the line.

● **Cycle modes of inverter pump by built-in relay:**

In this mode RY1 is always used and RY2~RY3 is used when required. 24-01 can only be set 0xxx (Relay 4 cannot be set.) and 24-02 is not visible.

| 24-03 | Detection Time on Fmax (Upper Limit Frequency) |
|-------|--|
| Range | 【1.0 ~ 600.0】 Sec |

The inverter turns on the next pump (relay/motor) when the inverter output frequency is equal to the upper limit frequency (00-12 x 01-02) for the time specified in 24-03. This value depends on the response of the system. Note: When the value of the Detection Time on Fmax is set too low may result in the system to become unstable.

| | |
|--------------|---|
| 24-04 | Detection Time on Fmin (Lower Limit Frequency) |
| Range | 【1.0 ~ 600.0】 Sec |

The inverter turns off the last pump (relay/motor) when the inverter output frequency is equal to the lower limit frequency (00-13 x 01-02) for the time specified in 24-04. This value depends on the response of the system. Note: When the value of the Detection Time on Fmin is set too low may result in the system to become unstable.

| | |
|--------------|---|
| 24-05 | Switching Time of Magnetic Contactor |
| Range | 【0.1~2.00】 Sec |

When a motor originally controller by the inverter is switched over to commercial AC power supply or when the motor is originally driven by the commercial AC power supply is switched by the inverter, parameter 24-05 is used to prevent the condition that both the inverter and commercial AC power are connected together resulting in a short circuit between the inverter output and AC power supply.

Generally, the off-to-on time of magnetic contactor is longer than the on-to-off time. So 24-05 should be set to a value greater than the turn-on time of the relay on relay card plus the turn-on time of magnetic contactor.

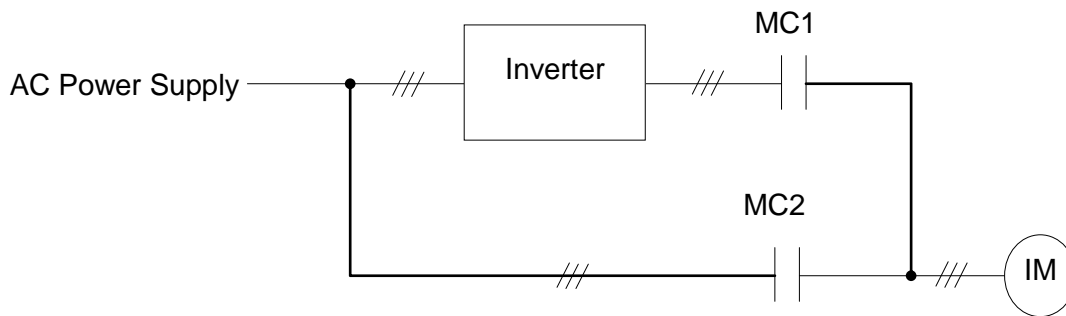

Figure 4.3.119 Diagram of a single cycle mode inverter pump

| | |
|--------------|-----------------------------|
| 24-06 | Relay Frequency Bias |
| Range | 【0.0~20.0】 % |

Parameter 24-06 allows the system to switch the relays on 1 to 8 relay card on or off quicker. Example, 00-12 = 80%, and 00-13 = 20%, then:

- If 24-06 = 0%, the output frequency needs to reach 80% of the maximum frequency to turn the relay on; the output frequency needs to reach 20% of the minimum frequency to turn the relay off.
- If 24-06 = 5%, the output frequency needs to reach 75% of the maximum frequency to turn the relay on; the output frequency needs to reach 25% of the minimum frequency to turn the relay off.

| | |
|--------------|---|
| 24-07 | Pump Control Source Selection |
| Range | 【0】 : Relay card 【1】 : Control board |

24-07 = 0: Use 1 to 8 relay option card

24-07 = 1: Use built-in relays on control board

If 1 to 8 relay card is unavailable:

- ① 24-00 range is 1~3 and 6.
- ② 24-01 is set to 0xxx (Relay 4 is disabled).
- ③ 24-02 is set to 0000 (Relay 5~8 are disabled).

Note: Set 24-00, 24-01, 24-02 and 24-07 as described above to avoid programming errors.

Refer to the following table for controlling the maximum number of pumps for different settings of 24-00 and 24-07.

| Setting value of 24-00 | Inverter pump Modes | No. of relay required by one pump | 24-07=0 (Relay in 1 to 8 pump card) | 24-07=1 (Relay in the control board) |
|-------------------------------|----------------------------|--|--|---|
| 1-3 | Fixed Modes | 1 | 8 PUMP | 3 PUMP |
| 4,5 | Cycle Modes | 2 | 4 PUMP | None |
| 6 | Cycle Modes | 1 | None | 3 PUMP |

- Function for R1A becomes Relay1 and parameter 03-11 is not used.
- Function for R2A becomes Relay2 and parameter 03-12 is not used.
- Function for R3A becomes Relay3 and parameter 03-39 is not used.

- The following examples are the timing chart for switching ON/OFF relays in fixed mode. Set 24-00=1, 24-06=0, enable the PID function and Relay1 to Relay 4 on the 1 to 8 relay card. Motor 1 is connected to inverter and motor 2~4 are connected to AC power supply. MC of AC power supply is controlled by the external circuit control. Wiring diagram refer to Fig. 4.3.126.
- ◇ Output frequency (F_{out}) reaches F_{max} (00-12*01-02) for the time specified in 24-03, Relay 2 turns on, motor 2 starts running. Motor 1 decelerates to F_{min} (00-13*01-02) after relay 2 turns on; when F_{min} is reached PID control turns on again.

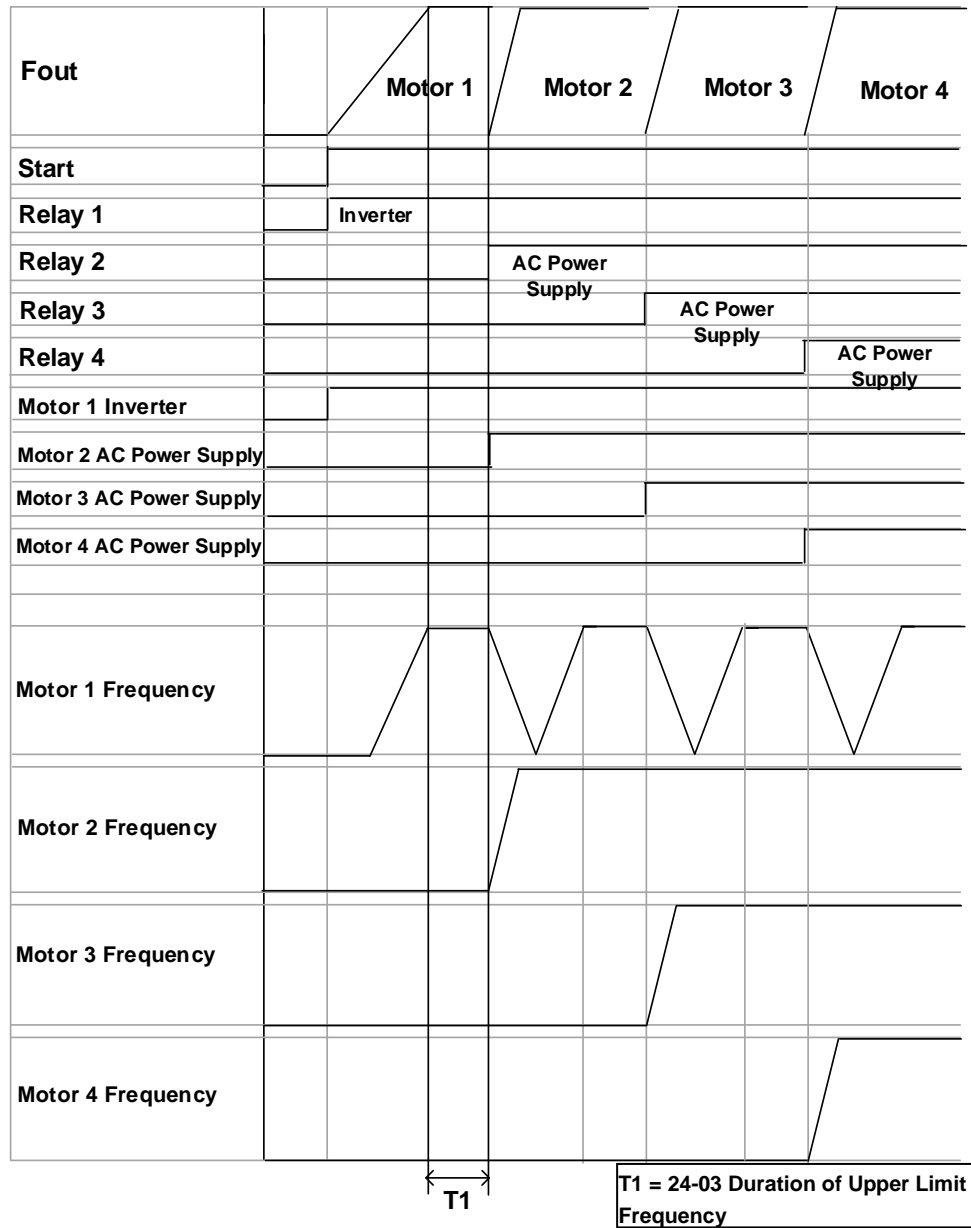

Figure 4.3.120 Timing chart of switching ON relays in fixed mode

- Output frequency (F_{out}) decreases to the F_{min} (00-13*01-02) for the time specified in 24-04, relay 4 turns off and motor 4 coasts to stop. Motor 1 accelerates to F_{max} (00-12*01-02) after relay 4 turns off; when F_{max} is reached PID control turns on again.

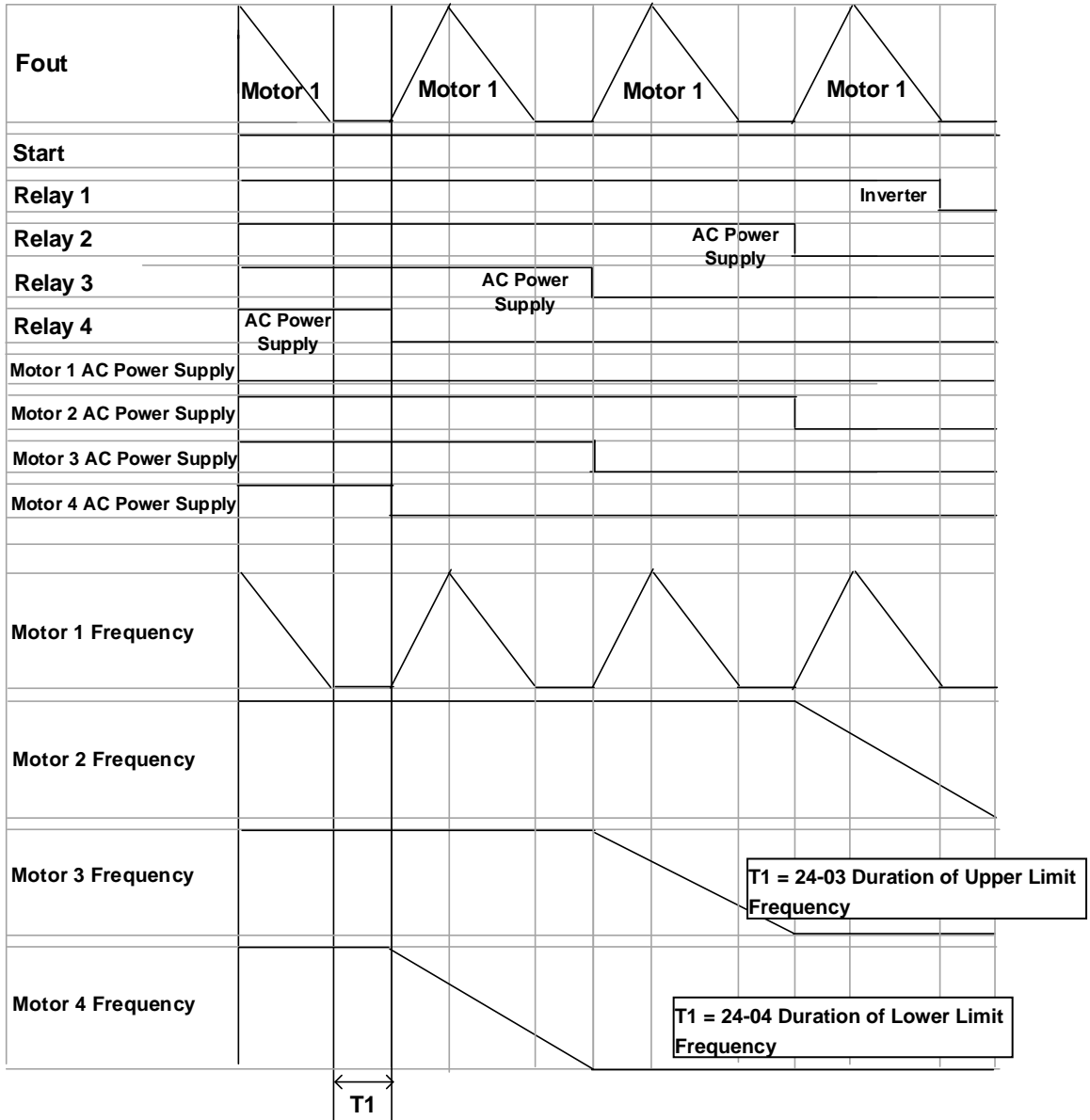

Figure 4.3.121 Timing chart of switching OFF relays in fixed mode

- The following examples are the timing chart of switching relays on and off in cycle modes. Set 24-00=1, 24-06=0, enable the PID function and Relay 1 to Relay 4 on the 1 to 8 pump card. Fig 4.3.119 is the timing diagram of cycle mode operation; please refer to Appendix A for a detailed wiring of the system.
- ◇ Output frequency (Fout) reaches Fmax (00-12*01-02) for the time specified in Fmax (24-03), relay 1 turns off and inverter output turns off.
- ◇ Relay 1 and Relay 2 turn on and the inverter starts running after the MC switching time, 24-05 has expired.

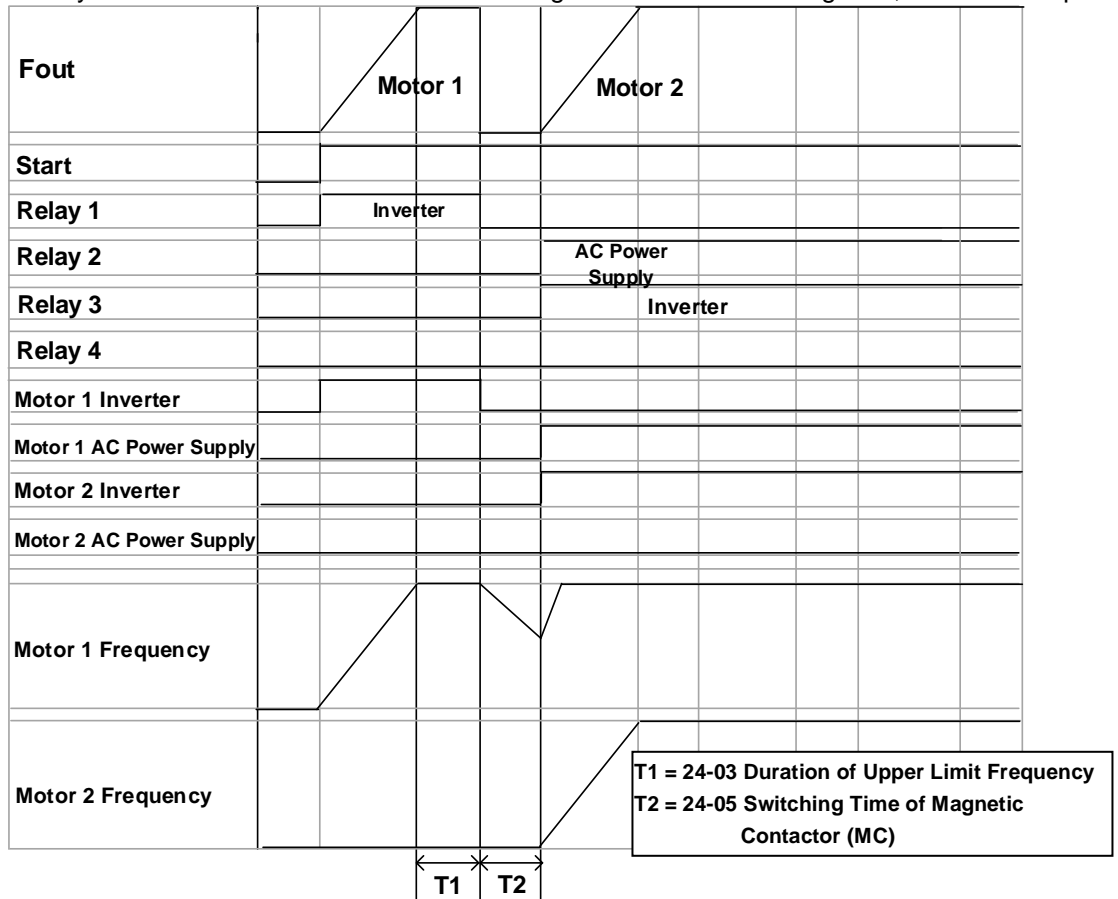

Figure 4.3.122 Timing chart of switching ON relays in cycle mode

- Output frequency (F_{out}) reaches F_{min} (00-13*01-02) for the time specified in 24-04, relay 2 turns off and the inverter accelerates to F_{max} (00-12*01-02). When F_{max} is reached PID control is turned on again. If the feedback is still higher than the setpoint motor 2 will decelerate to F_{min} again.

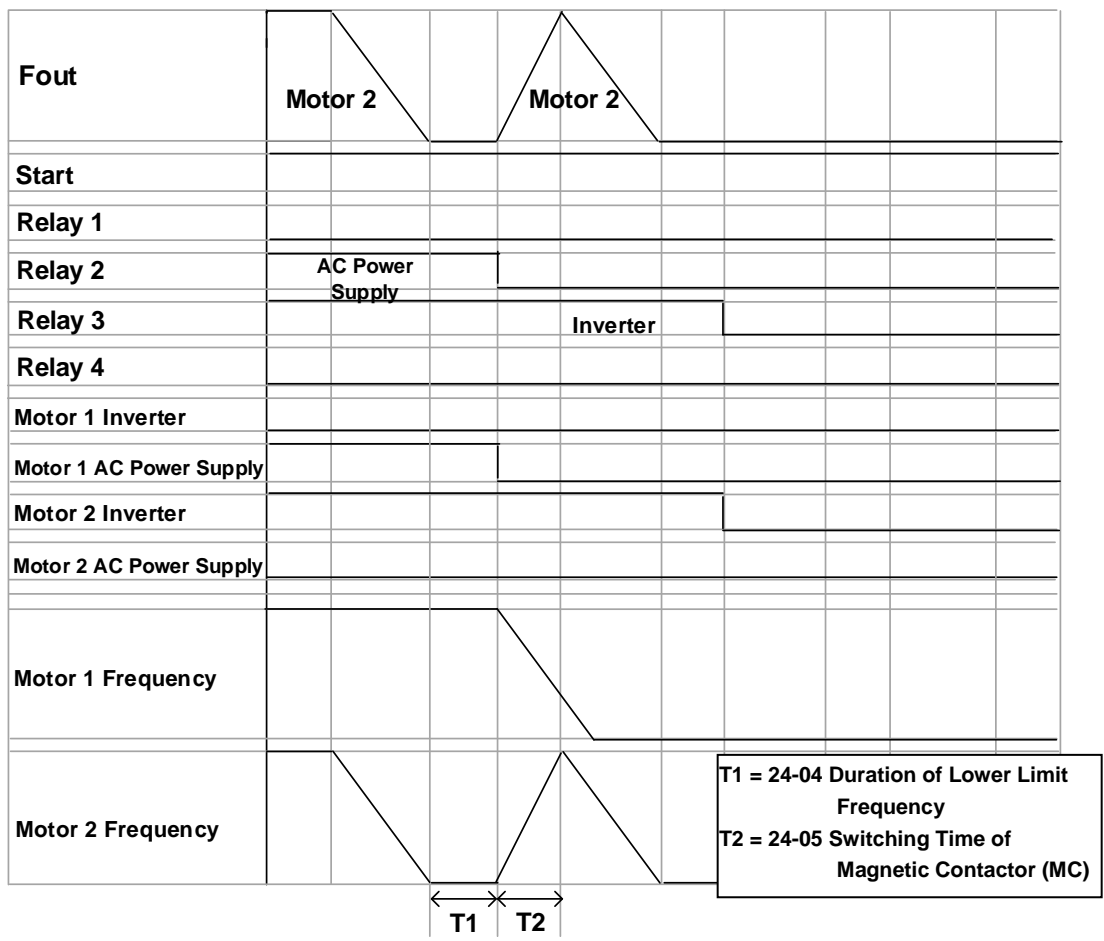

Figure 4.3.123 Timing chart of switching OFF the relays in cycle mode

- The following examples are the timing charts for switching relays on and off in cycle mode using the built-in relays. Set 24-00=1, 24-06=0, enable the PID function. Relay1 to Relay3 are now set to operate as R1A to R3A. Fig 4.3.118 is the timing diagram of this mode; please refer to Appendix A for a detailed wiring diagram of the system.
- ◇ Output frequency (Fout) reaches the upper limit frequency (00-12) for the detection time specified in 24-03, relay 1 turns off and the inverter output turns off.
- ◇ Although relay 2 turns on in advance, the inverter does not start and relay 1 does not turn on until twice the MC switching time (24-05) has expired.

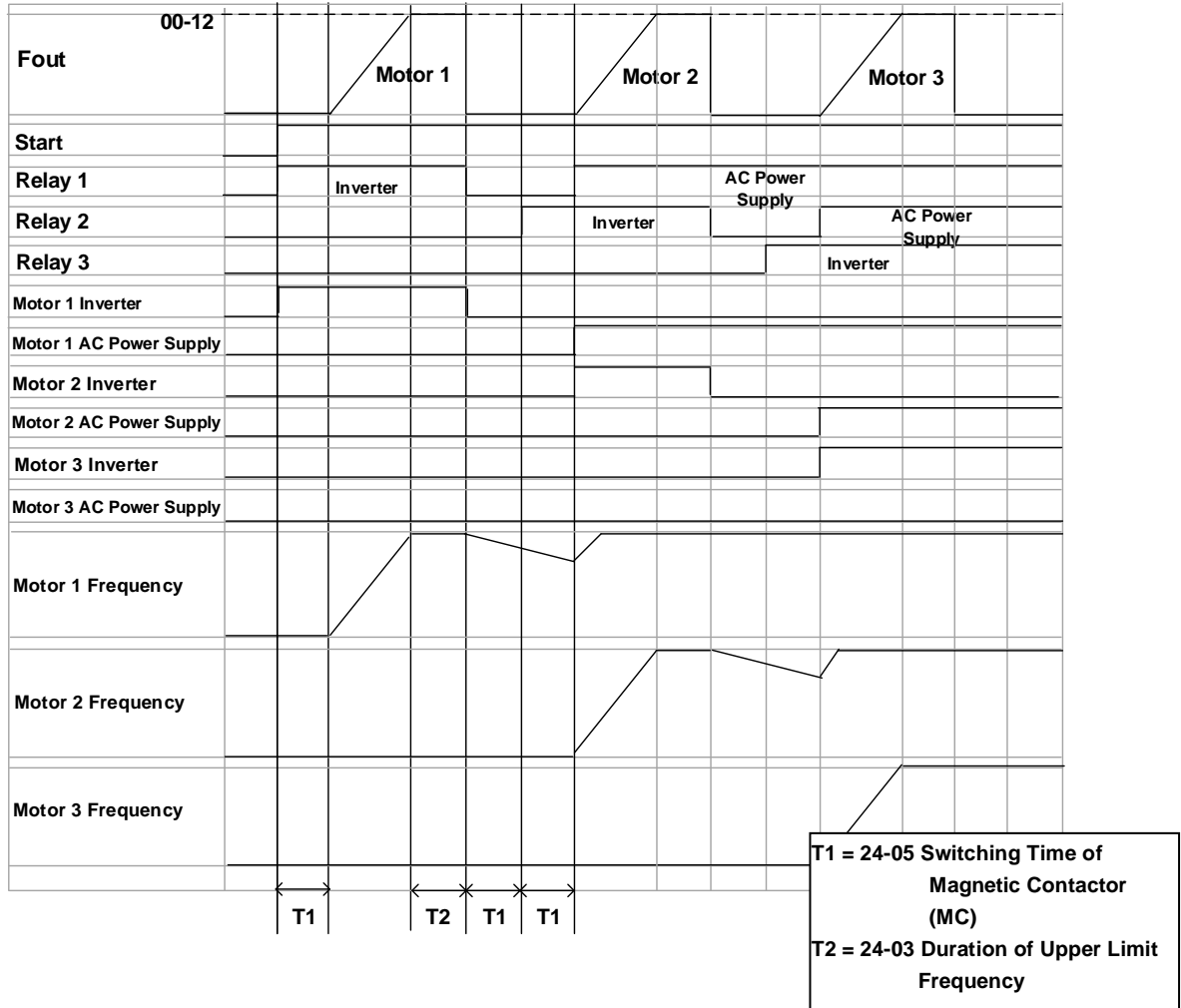

Figure 4.3.124 Timing chart for switching ON/OFF relays using the built-in relays

- ◇ When pressure feedback signal is higher than the setpoint, output frequency (F_{out}) starts decreasing. Relay 1 turns off when the output frequency reaches the lower limit frequency (00-13*01-02) for the time specified in 24-04.

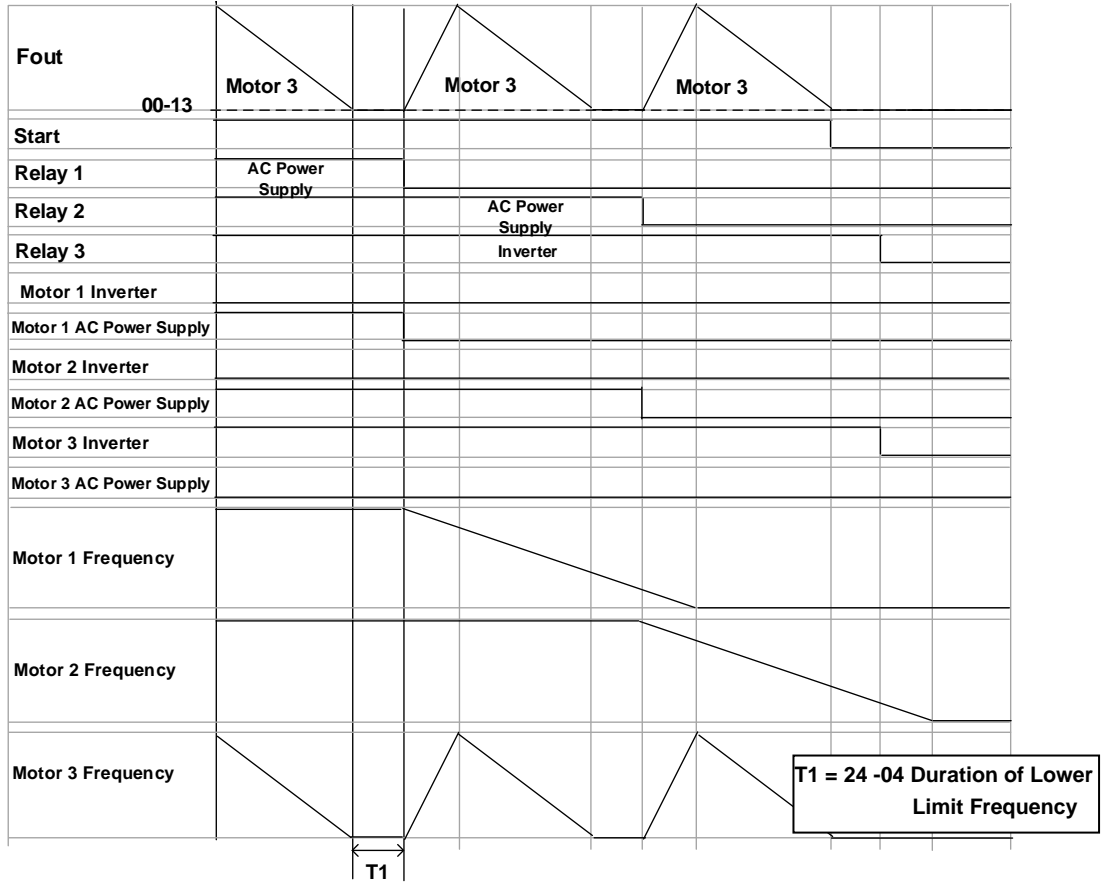

Figure 4.3.125 Timing using relays on the control card

■ Wiring for 1 to 8 Pump Card and 1 to 3 Relay Modes

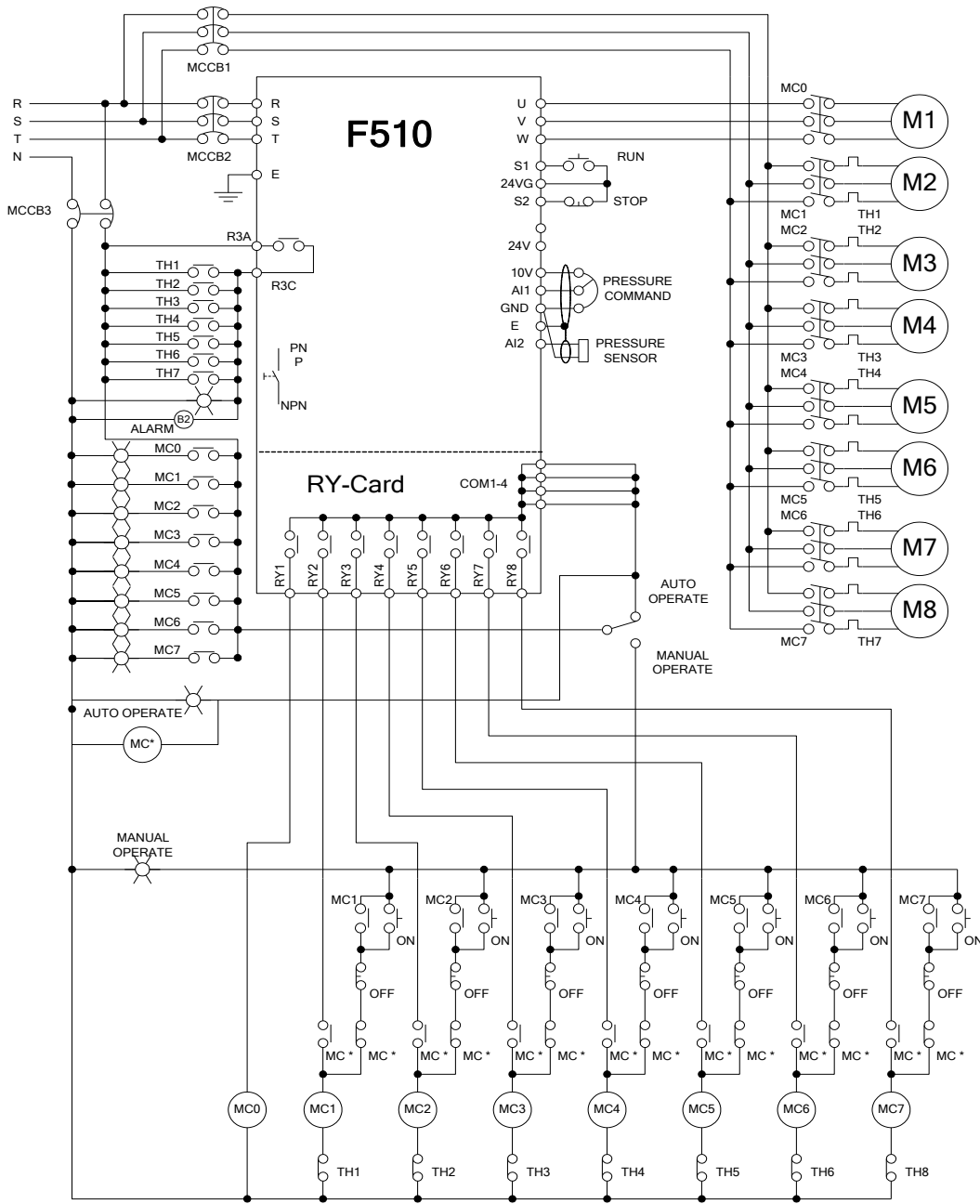

Figure 4.3.126 Fixed mode inverter pump wiring using 1 to 8 option card

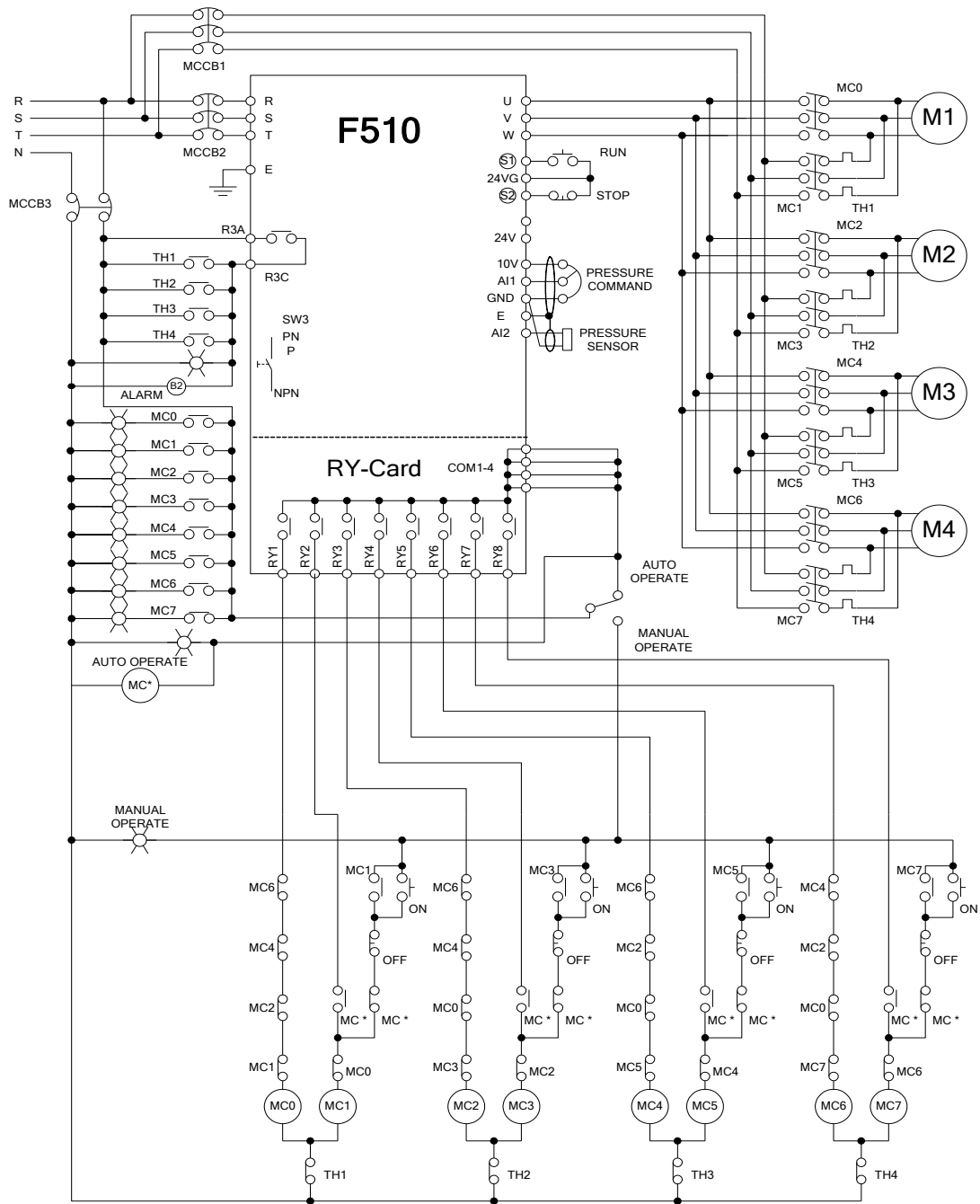

Figure 4.3.127 Cycle mode inverter pump wiring using 1 to 8 option card

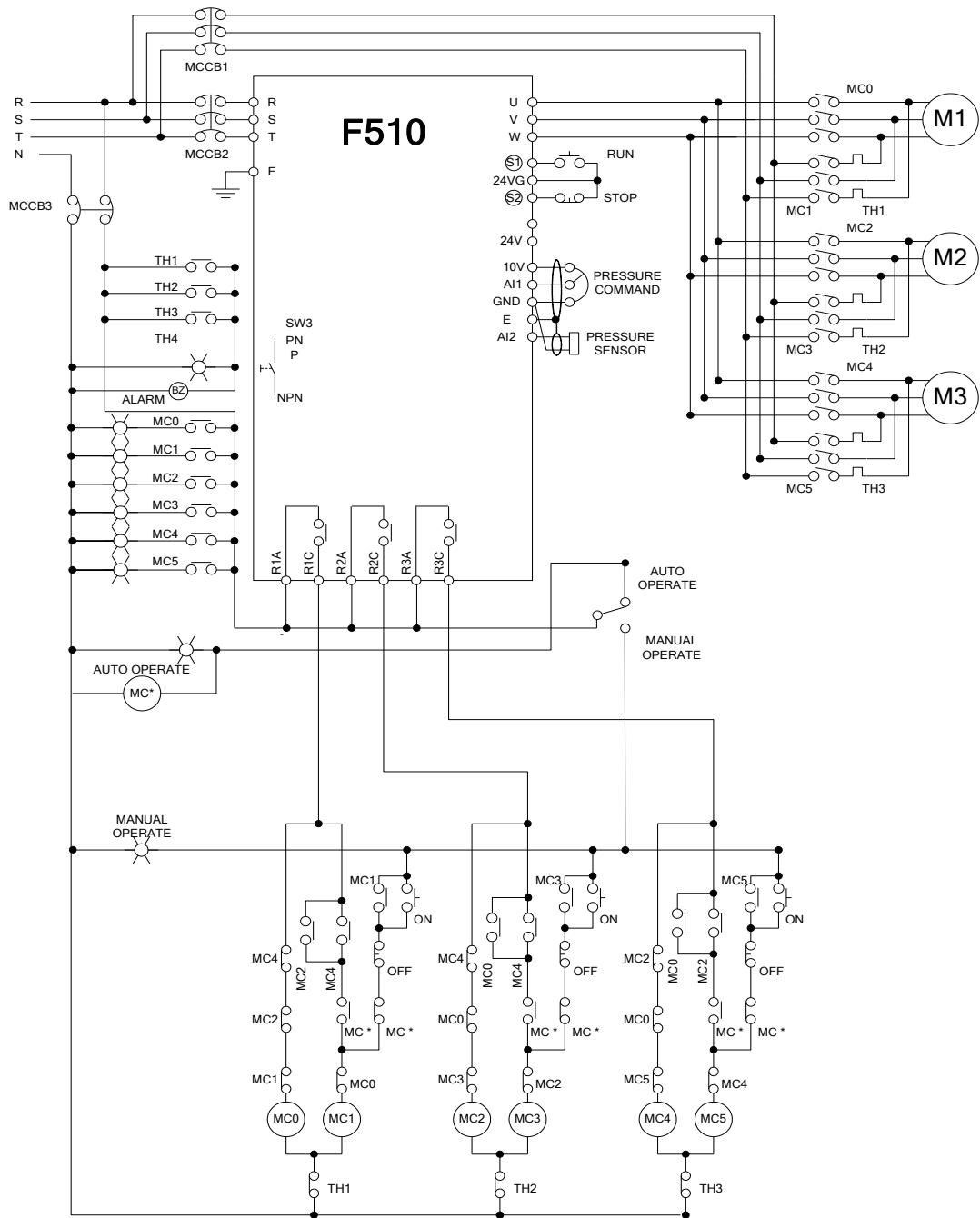

Figure 4.3.128: Cycle mode inverter pump wiring using relays on the control card

5. Check motor rotation and direction

This test is to be performed solely from the inverter keypad. Apply power to the inverter after all the electrical connections have been made and protective covers have been re-attached. At this point, **DO NOT RUN THE MOTOR**, the keypad should display as shown below in Fig. 5.1 and the speed reference 12-16=005.00Hz should be blinking at the parameter code “12-16”.

Important: Motor rotation and direction only applies to standard AC motors with a base frequency of 60Hz. For 50Hz or other frequency AC motors please set the max frequency and base frequency in group 01 accordingly before running the motors.



Fig 5.1: Keypad (Stopped)



Fig 5.2: Keypad (Running)

Next press the **RUN** key, see Fig 5.2. The motor should now be operating at low speed running in forward (clockwise) direction. The parameter code 12-17 shown at the bottom left corner of the screen will change from 12-17=000.00Hz to 12-17=005.00Hz. Next press **STOP** key to stop the motor.

If the motor rotation is incorrect, power down the inverter.

After the power has been turned OFF, wait at least ten minutes until the charge indicator extinguishes completely before touching any wiring, circuit boards or components.

Using Safety precaution, and referring to section 3.8 exchange any two of the three output leads to the motor (U/T1, V/T2 and W/T3). After the wiring change, repeat this step and recheck motor direction.

6. Speed Reference Command Configuration

The inverter offers users several choices to set the speed reference source. The most commonly used methods are described in the next sections.

Frequency reference command is selected with parameter 00-05.

00-05: Main Frequency Command (Frequency Source)

This function sets the frequency command source.

Setting Range: 0 to 7

To set parameter 00-05:

- After power-up press the **DSP/FUN** key
- Select **00 Basic Fun**
- Press **READ/ ENTER** key
- Select parameter -05 with the **UP/DOWN ▲** and **▼** keys and press the **READ/ ENTER** key.

In the parameter list move cursor to 00-05 with the **UP/DOWN** keys and press **READ/ ENTER** key to select.

| 00-05 | Main Frequency Command Source Selection |
|-------|--|
| Range | 0: Keypad 1: External control (analog) 2: Terminal UP / DOWN 3: Communication control 6: RTC 7: AI2 Auxiliary Frequency |

6.1 Reference from Keypad

Speed reference from the keypad is the default setting. Press the **READ/ ENTER** key first and use the **</RESET**, **▲** and **▼** keys to change the speed reference.

6.2 Reference from External Analog Signal (0-10V / 4-20mA)

Analog Reference: 0 – 10 V (Setting 00-05 = 1)

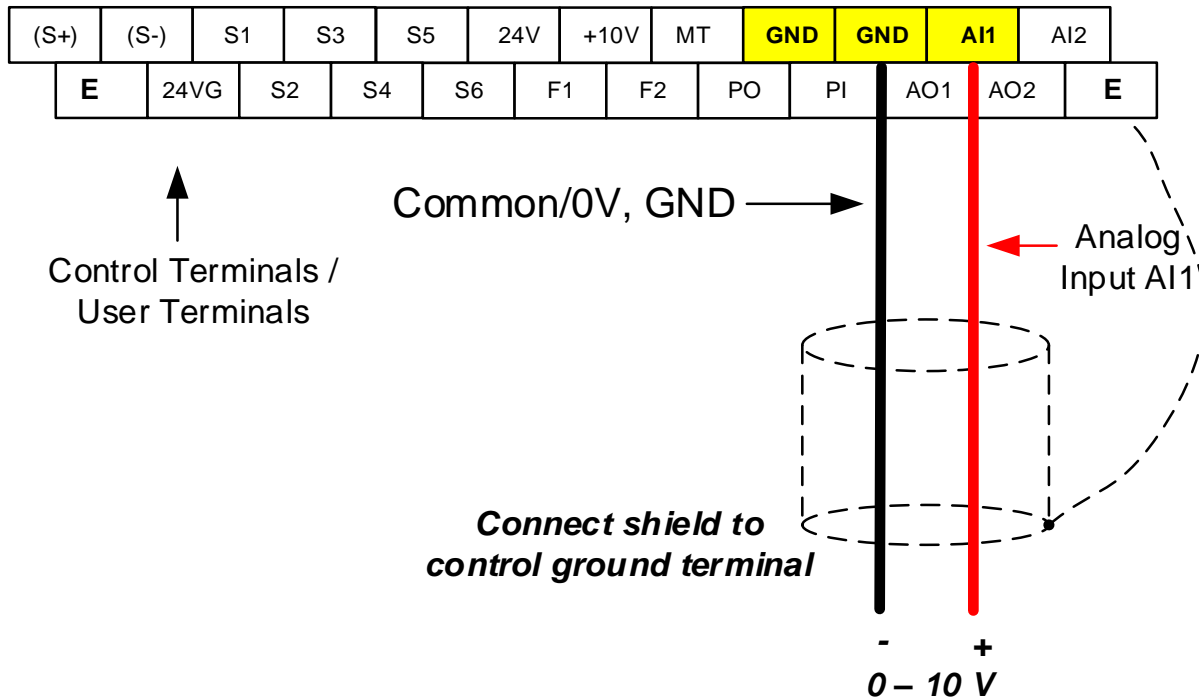

Analog Reference: Potentiometer / Speed Pot (Setting 00-05 = 1)

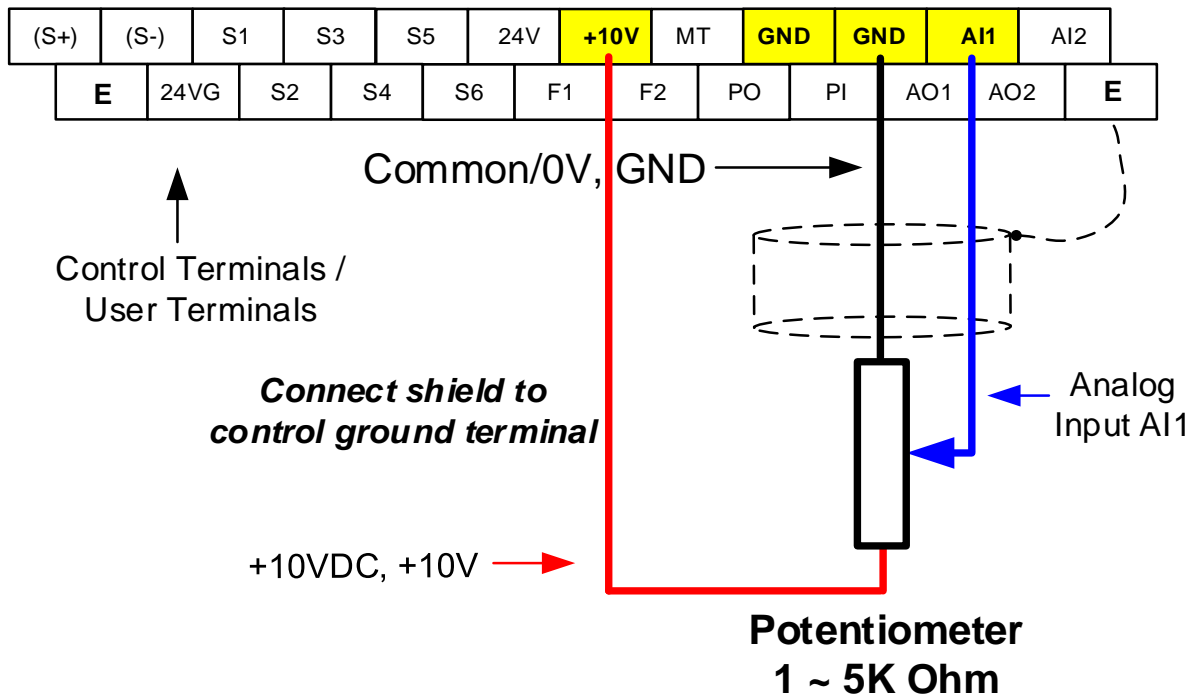

Analog Reference: 4 – 20mA (Setting 00-05 = 1)

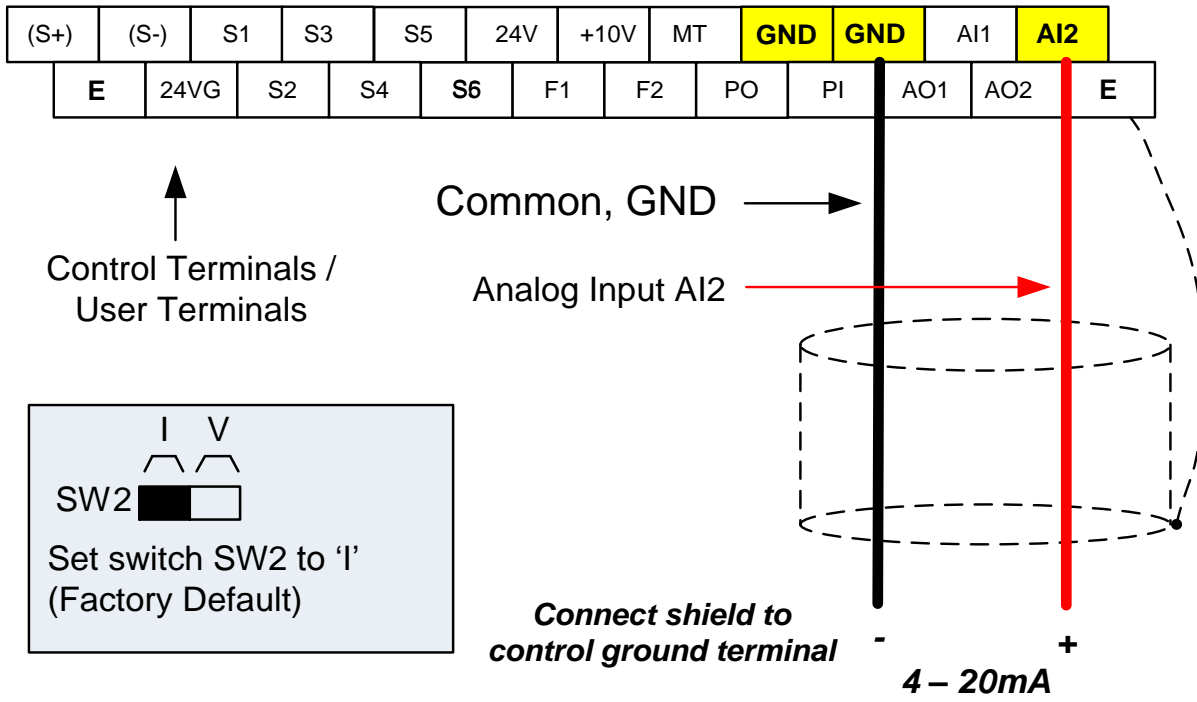

6.3 Reference from Serial Communication RS485 (00-05=3)

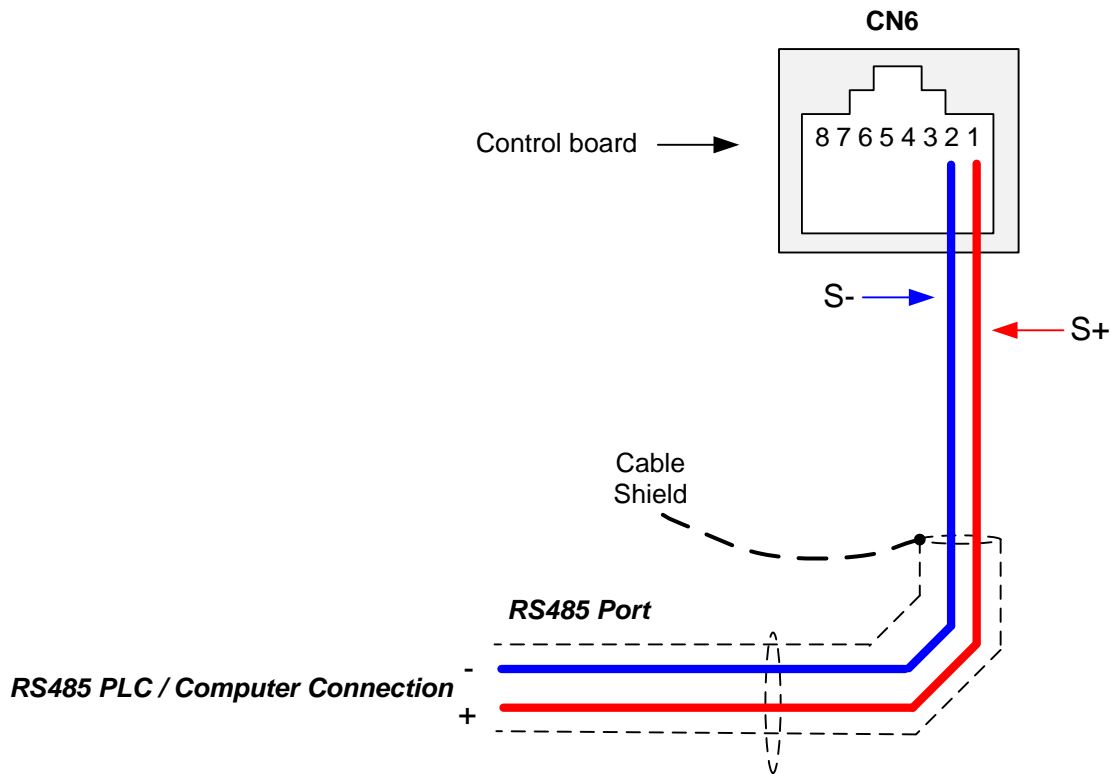

To set the speed reference for the inverter via serial communication parameter 00-05 has be set to “3” for frequency command via serial communication.

Default Communication Setting is: Address “1”, 9600 Bits/sec, 1 Start Bit, 1 Stop Bit, and No Parity

The serial communication link function uses RS485 Modbus RTU protocol and allows for:

- 1) Monitoring (data monitoring, function data check).
- 2) Frequency setting.
- 3) Operation command (FWD, REV, and other commands for digital input).
- 4) Write function data.

Frequency Reference Command Register

Inverter Frequency Reference Register: 2502 (Hexadecimal) - Bit 0 – Bit 15: 0.00 ~ 400.00 Hz

Examples:

Frequency Reference Command: 10.00 Hz (Inverter Node Address: 01)

Command String (hexadecimal): 01 06 25 02 03 E8 23 B8

To set the frequency reference to 10.00, a value of '1000' (03E8h) has to be send to the inverter.

Frequency Reference Command: 30.00 Hz (Inverter Node Address: 01)

Command String (hexadecimal): 01 06 25 02 0B B8 24 44

To set the frequency reference to 30.00, a value of '3000' (0BB8h) has to be send to the inverter.

Frequency Reference Command: 60.00 Hz (Inverter Node Address: 01)

Command String (hexadecimal): 01 06 25 02 17 70 2D 12

To set the frequency reference to 60.00, a value of '6000' (1770h) has to be send to the inverter

Note: The last 2 bytes of the command strings consist of a CRC16 checksum, please refer to section 4.5 of the instruction manual for additional information.

6.4 Reference from two Analog Inputs

Analog input AI1 is used as master frequency reference and analog input AI2 is used as auxiliary frequency reference.

Analog Reference AI1: 0 – 10 V (Setting 00-05 = 1)

Analog Reference AI2: 0 – 10 V (Setting 00-06 = 7)

| AI1 – Analog Input 1 | AI2 – Analog Input 2 | 04-00 Setting (Default = 1) | Dipswitch SW2 (Default 'V') |
|----------------------|----------------------|-----------------------------|-----------------------------|
| 0 ~ 10V | 0 ~ 10V | 0 | Set to 'V' |
| 0 ~ 10V | 4 ~ 20mA | 1 | Set to 'I' |

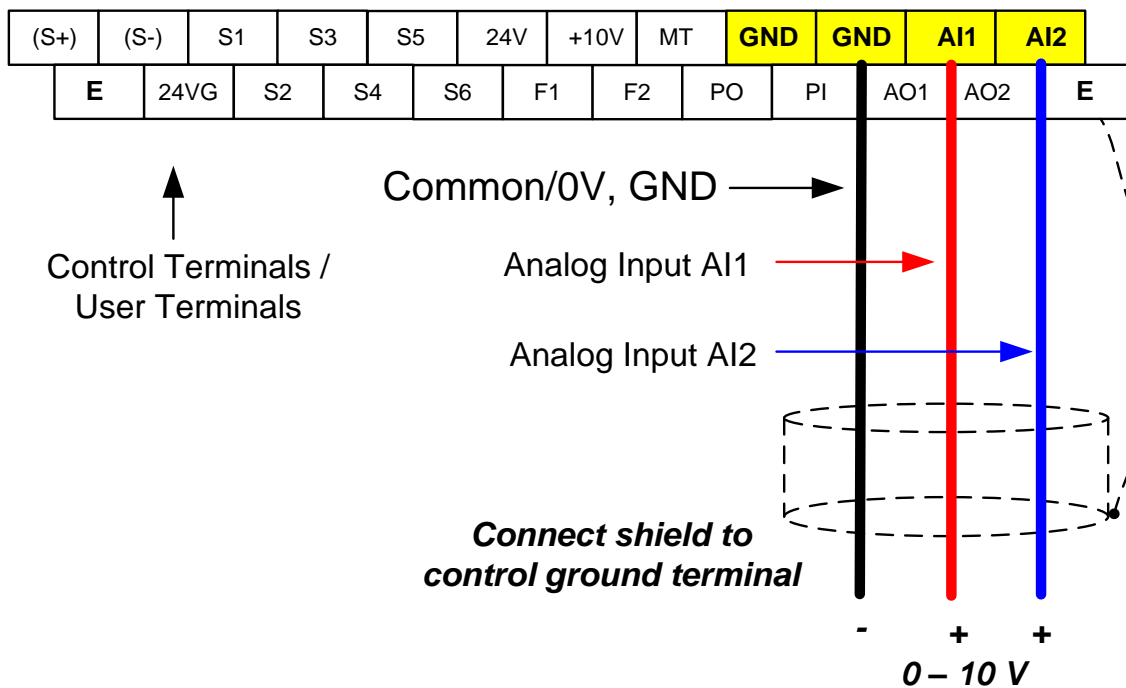

6.5 Change Frequency Unit from Hz to rpm

Enter the number of motor poles in 16-03 to change the display units from Hz to rpm.

| 16-03 | Display unit |
|-------|--|
| Range | 0: Display unit is Hz (Resolution is 0.01Hz) |
| | 1: Display unit is % (Resolution is 0.01%) |
| | 2~39: Display unit rpm, (uses number of motor poles to calculate) |
| | 40~9999: 100% is XXXX with no decimals (integer only) |
| | 10001~19999: 100% is XXX.X with 1 decimal |
| | 20001~29999: 100% is XX.XX with 2 decimals |
| | 30001~39999: 100% is X.XXX with 3 decimals |

Example: Motor poles 4, 16-03 = 4.

7. Operation Method Configuration (Run / Stop)

The inverter offers users several choices to run and stop from different sources. The most commonly used methods are described in the next sections.

Operation command is selected with parameter 00-02.

00-02: Run Command Selection

This function sets the frequency command source.

Setting Range: 0 to 4

To set parameter 00-01:

- After power-up press the **DSP/FUN** key
- Select **00 Basic Fun**
- Press **READ/ ENTER** key
- Select parameter -01 with the **UP/DOWN ▲** and **▼** keys and press the **READ/ ENTER** key.

In the parameter list move cursor to 00-01 with the **UP/DOWN** keys and press **READ/ ENTER** key to select.

| 00-02 | Run Command Selection |
|-------|--|
| Range | 0: Keypad control 1: External terminal control 2: Communication control 3: PLC 4: RTC |

7.1 Run/Stop from the Keypad (00-02=0) – Default Setting

Use the **RUN** key to run the drive in forward direction and the **FWD/REV** key to change the motor direction. (Note: to disable reverse direction set parameter 11-01 to 1)

Press **STOP** key to stop the inverter. (Note: Stop method can be set with parameter 07-09, default is **deceleration to stop**).



7.2 Run/Stop from External Switch / Contact or Pushbutton (00-02=1)

Use an external contact or switch to Run and Stop the inverter.

Permanent Switch / Contact

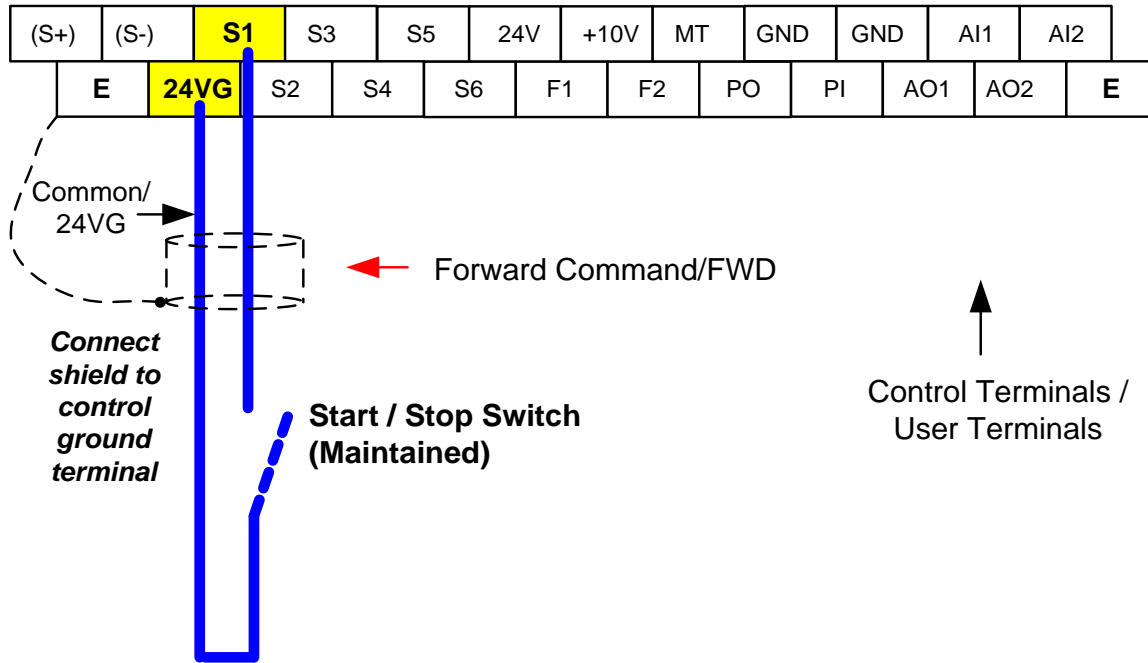

Momentary Contacts (Push Buttons)

Use push button / momentary switch to Run and Stop the inverter.

Set parameter 13-08 to 3, 5 or 7 for 3-wire program initialization, multi-function input terminal S1 is set to run operation, S2 for stop operation and S5 for forward/reverse command.

00-01 Operation Method = 1

03-05 Terminal S5 Function = 26

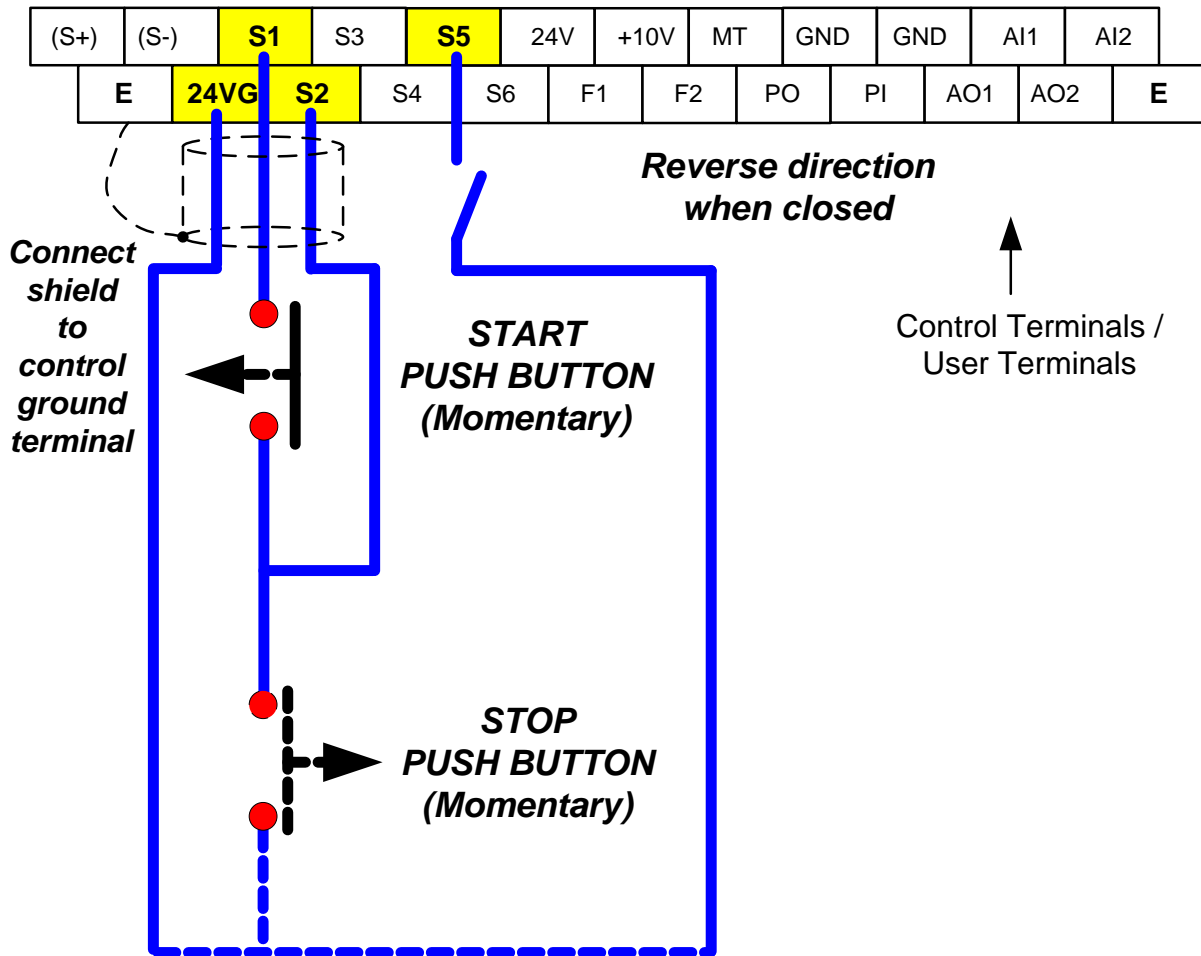

Note: Stop mode selection can be set with parameter 07-09, default is **deceleration to stop**.

7.3 Run/Stop from Serial Communication RS485 (00-02=3)

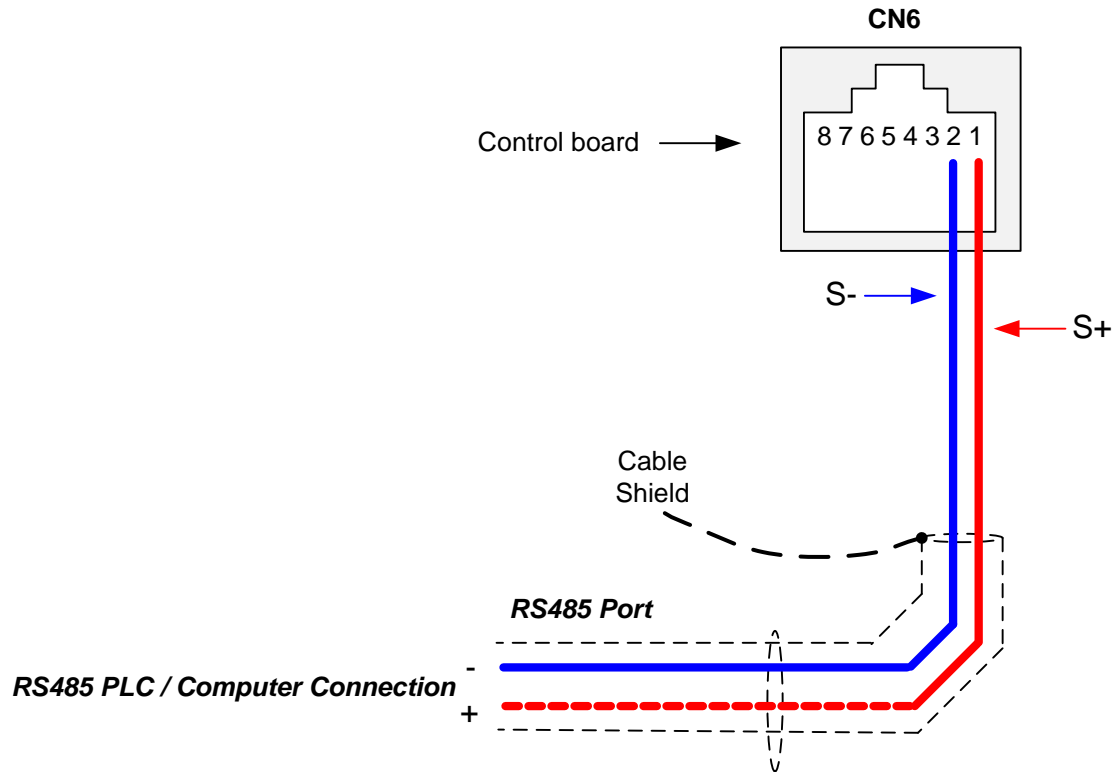

To control (Run/Stop) the inverter via serial communication parameter 00-02 has be set to either a “3” for communication control.

Default Communication Setting is: Address “1”, 9600 Bits/sec, 1 Start Bit, 1 Stop Bit, and No Parity

The serial communication link function uses RS485 Modbus RTU protocol and allows for:

- 1) Monitoring (data monitoring, function data check).
- 2) Frequency setting.
- 3) Operation command (FWD, REV, and other commands for digital input).
- 4) Write function data.

Command Register

Inverter Command Register: 2501 (Hexadecimal)

Bit 0: Run Forward

Bit 1: Run Reverse

Bit 2 ~ Bit 15: Refer to the chapter XX of this manual

Examples:

Run Forward Command (Inverter Node Address: 01)

Command String (hexadecimal): 01 06 25 01 00 01 12 C6

Run Reverse Command (Inverter Node Address: 01)

Command String (hexadecimal): 01 06 25 01 00 03 93 07

Stop Command (Inverter Node Address: 01)

Command String (hexadecimal): 01 06 25 01 00 00 D3 06

Note: The last 2 bytes of the command strings consist of a CRC16 checksum, please refer to section 4.5 of the instruction manual for additional information.

8. Motor and Application Specific Settings

It is essential that before running the motor, the motor nameplate data matches the motor data in the inverter.

8.1 Set Motor Nameplate Data (02-01, 02-05)

02-05 Rated power of motor 1

The nominal motor rated capacity is set at the factory. Please verify that the motor name plate data matches the motor rated capacity shown in parameter 02-05. The setting should only be changed when driving a motor with a different capacity.

Range: 0.00 to 600.00 kW (1HP = 0.746 kW)

To set parameter 02-05:

- After power-up press the **DSP/FUN** key
- Select **02 Motor Parameter**
- Press **READ/ ENTER** key
- Select parameter -01 with the **UP/DOWN ▲** and **▼** keys and press the **READ/ ENTER** key.

Default values vary based on the inverter model.

02-01 Rated current of motor 1

The motor rated current is set at the factory based on the inverter model. Enter the motor rated current from the motor nameplate if it does not match the value shown in parameter 02-01.

Setting range: 0.01 to 600.00A

To set parameter 02-01:

- After power-up press the **DSP/FUN** key
 - Select **02 Motor Parameter**
 - Press **READ/ ENTER** key
 - Select parameter -01 with the **UP/DOWN ▲** and **▼** keys and press the **READ/ ENTER** key.
-

8.2 Acceleration and Deceleration Time (00-14, 00-15)

Acceleration and Deceleration times directly control the system dynamic response. In general, the longer the acceleration and deceleration time, the slower the system response, and the shorter time, the faster the response. An excessive amount of time can result in sluggish system performance while too short of a time may result in system instability.

The default values suggested normally result in good system performance for the majority of general purpose applications. If the values need to be adjusted, caution should be exercised, and the changes should be in small increments to avoid system instability.

00-14 Acceleration time 1

00-15 Deceleration time 1

These parameters set the acceleration and deceleration times of the output frequency from 0 to maximum frequency and from maximum frequency to 0.

To set parameter 00-14 or 00-15:

- After power-up press the **DSP/FUN** key
- Select **00 Basic Fun**
- Press **READ/ ENTER** key
- Select parameter -14 or -15 with the **UP/DOWN ▲** and **▼** keys and press the **READ/ ENTER** key.

Acceleration and deceleration times are represented by the three most significant (high order) digits. Set acceleration and deceleration times with respect to maximum frequency. The relationship between the set frequency value and acceleration/deceleration times is as follows:

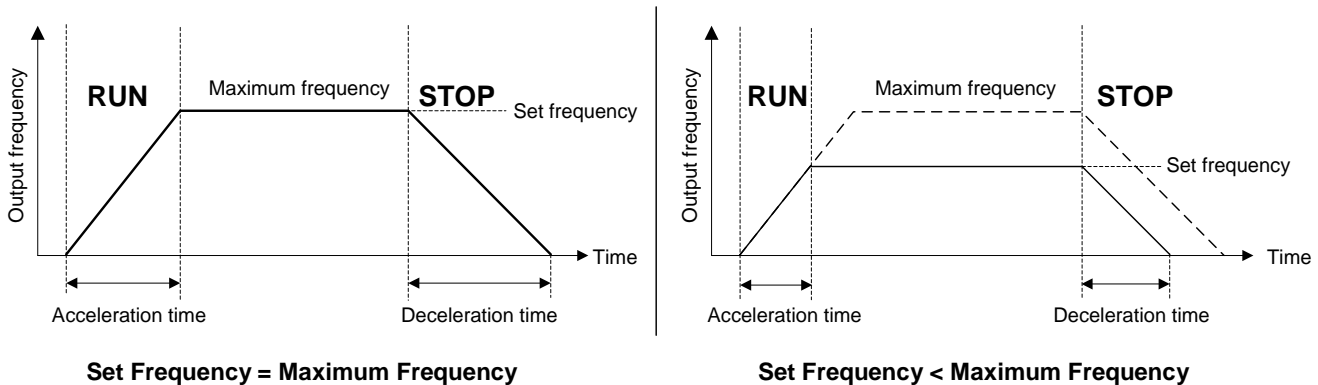

Note: If the set acceleration and deceleration times are set too low, the torque limiting function or stall prevention function can become activated if the load torque and or inertia are relatively high. This will prolong the acceleration and or deceleration times and not allow the set times to be followed. In this case the acceleration and or the deceleration times should be adjusted.

8.3 Automatic Energy Savings Function (11-19)

In the V/F control mode the automatic energy saving (AES) function automatically adjusts the output voltage and reduces the output current of the inverter to optimize energy savings based on the load.

The output power changes proportional to the motor load. Energy savings is minimal when the load exceeds 70% of the output power and savings become greater when the load decreases.

The parameter of automatic energy saving function has been set at the factory before shipment. In general, it is no need to adjust. If the motor characteristic has significant difference from TECO standard, please refer to the following commands for adjusting parameters:

Enable Automatic Energy Savings Function

To set parameters 11-19 to 11-24:

- After power-up press the **DSP/FUN** key
- Select **11 Auxiliary Function Group**
- Press **READ/ ENTER** key
- Select parameter -19 to -24 with the **UP/DOWN ▲ and ▼** keys and press the **READ/ ENTER** key.

- (1) To enable automatic energy saving function set 11-19 to 1.
- (2) Filter time of automatic energy saving (11-20)
- (3) Commissioning parameter of energy saving (11-21 to 11-22)

In AES mode, the optimum voltage value is calculated based on the load power requirement but is also affected by motor temperature and motor characteristic.

In certain applications the optimum AES voltage needs to be adjusted in order to achieve optimum energy savings. Use the following AES parameters for manual adjustment:

11-21: Voltage limit value of AES commissioning operation

Sets the voltage upper limit during automatic energy saving. 100% corresponds to 230V or 460V depending on the inverter class used.

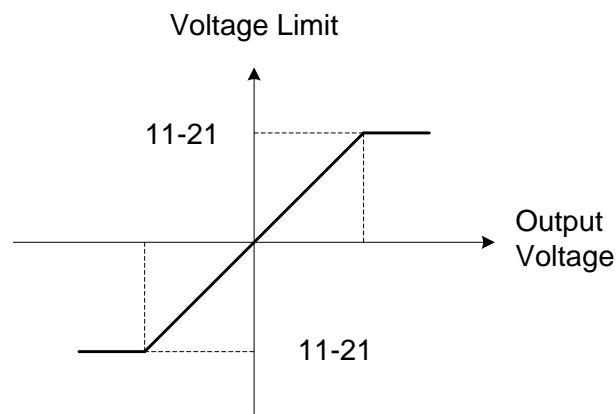

Voltage limit value of commissioning operation

11-22: Adjustment time of automatic energy saving

Sets sample time constant for measuring output power.

Reduce the value of 11-22 to increase response when the load changes.

Note: If the value of 11-22 is too low and the load is reduced the motor may become unstable.

11-23: Detection level of automatic energy saving

Sets the automatic energy saving output power detection level.

11-24: Coefficient of automatic energy saving

The coefficient is used to tune the automatic energy saving. Adjust the coefficient while running the inverter on light load while monitoring the output power. A lower setting means lower output voltage.

Notes:

- If the coefficient is set to low the motor may stall.
- Coefficient default value is based on the inverter rating. Set parameter 13-00. If the motor power does not match the inverter rating.

8.4 Emergency Stop

The emergency stop time is used in combination with multi-function digital input function #14 (Emergency stop). When emergency stop input is activated the inverter will decelerate to a stop using the Emergency stop time (00-26) and display the [EM STOP] condition on the keypad.

Note: To cancel the emergency stop condition the run command has to be removed and emergency stop input deactivated.

Example: Emergency Stop Switch set for input terminal S5 (03-04 = 14).

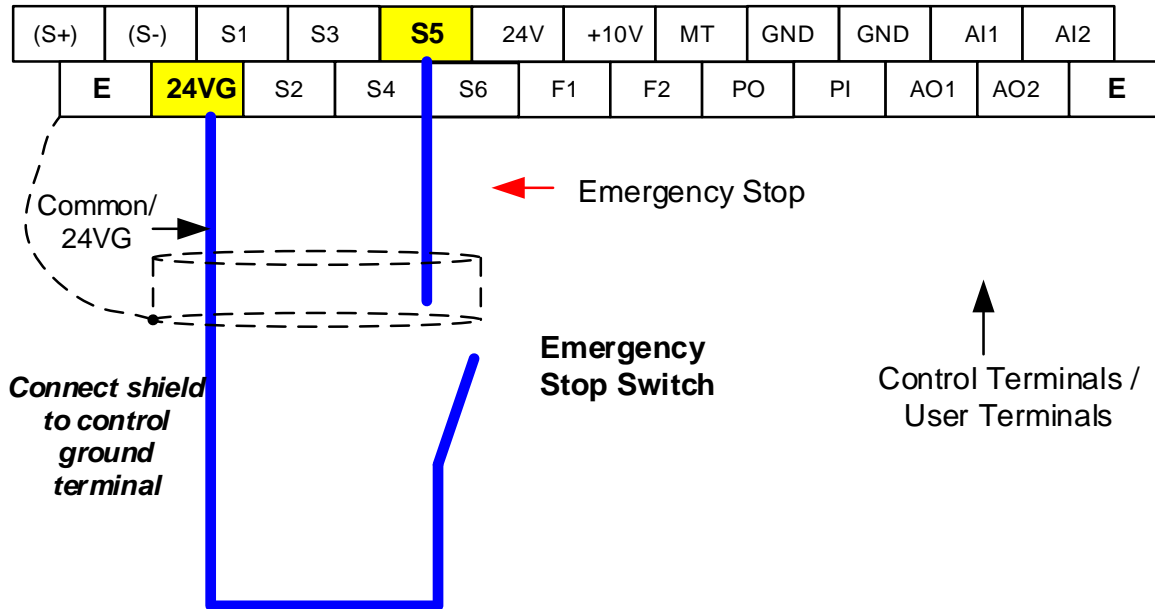

| | |
|-------|---------------------|
| 00-26 | Emergency stop time |
| Range | 0.0~6000.0 Sec |

8.5 Direct / Unattended Startup

The unattended startup function prevents the inverter from starting automatically when a run command is present at time of power-up. To use USP command set one of the multi-function digital input functions to #50 (USP Startup).

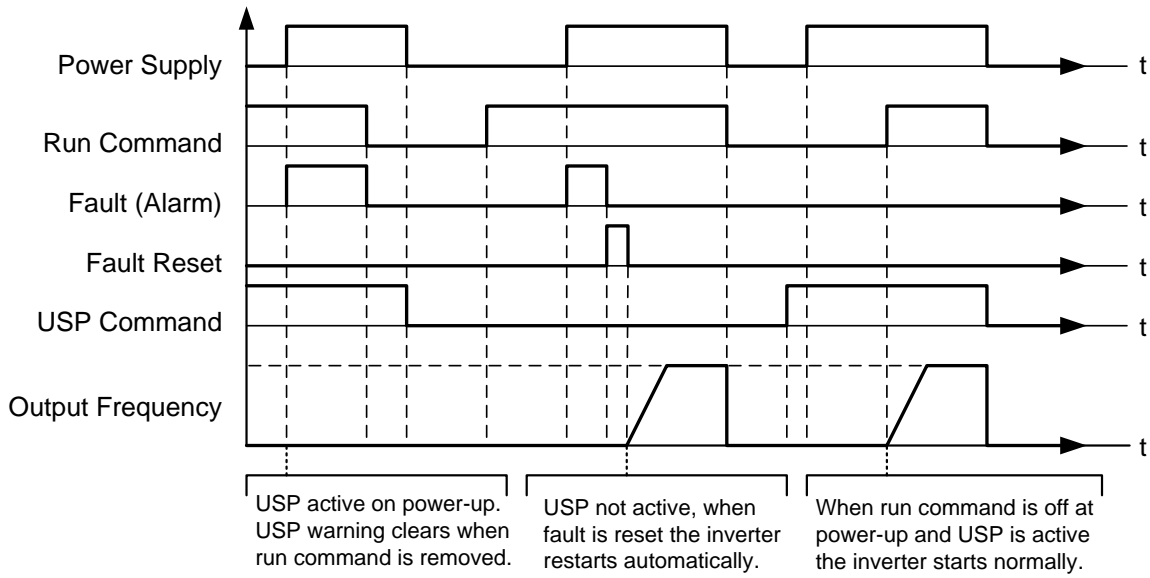

Unattended Startup Protection

8.6 Analog Output Setup

Signal: Use parameter 04-11 to select the analog output signal for AO1 and parameter 04-16 to select the analog output signal for AO2.

Gain: Use parameter 04-12 to adjust the gain for AO1 and parameter 04-17 to adjust the gain for AO2. Adjust the gain so that the analog output (10V/20mA) matches 100% of the selected analog output signal (04-11 for AO1 and 04-16 for AO2).

Bias: Use parameter 04-13 to adjust the bias for AO1 and parameter 04-18 to adjust the bias for AO2. Adjust the bias so that the analog output (0V/4mA) matches 0% of the selected analog output signal (04-11 for AO1 and 04-16 for AO2).

Example: Analog Output 1 Wiring

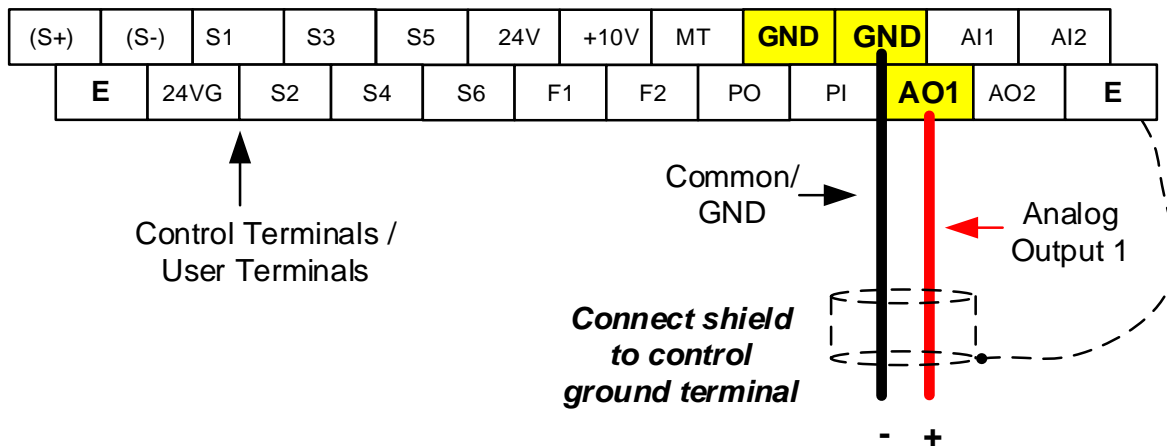

| 04-11 | AO1 function Setting | |
|-------|-------------------------------|---|
| Range | 0: Output frequency | 14: Reserved |
| | 1: Frequency command | 15: ASR output |
| | 2: Output voltage | 16: Reserved |
| | 3: DC voltage | 17: q-axis voltage |
| | 4: Output current | 18: d-axis voltage |
| | 5: Output power | 19: Reserved |
| | 6: Motor speed | 20: Reserved |
| | 7: Output power factor | 21: PID input |
| | 8: AI1 input | 22: PID output |
| | 9: AI2 input | 23: PID target value |
| | 10: Torque command | 24: PID feedback value |
| | 11: q -axis current | 25: Output frequency of the soft starter |
| | 12: d-axis current | 26: Reserved |
| | 13: Speed deviation | 27: Reserved |

| | |
|--------------|-------------------------------|
| 04-12 | AO1 gain value |
| Range | 0.0~1000.0% |
| 04-13 | AO1 bias-voltage value |
| Range | -100.0~100.0% |
| 04-16 | AO2 function Setting |
| Range | See parameter 04-11 |
| 04-17 | AO2 gain value |
| Range | 0.0~1000.0% |
| 04-18 | AO2 bias-voltage value |
| Range | -100.0~100.0% |

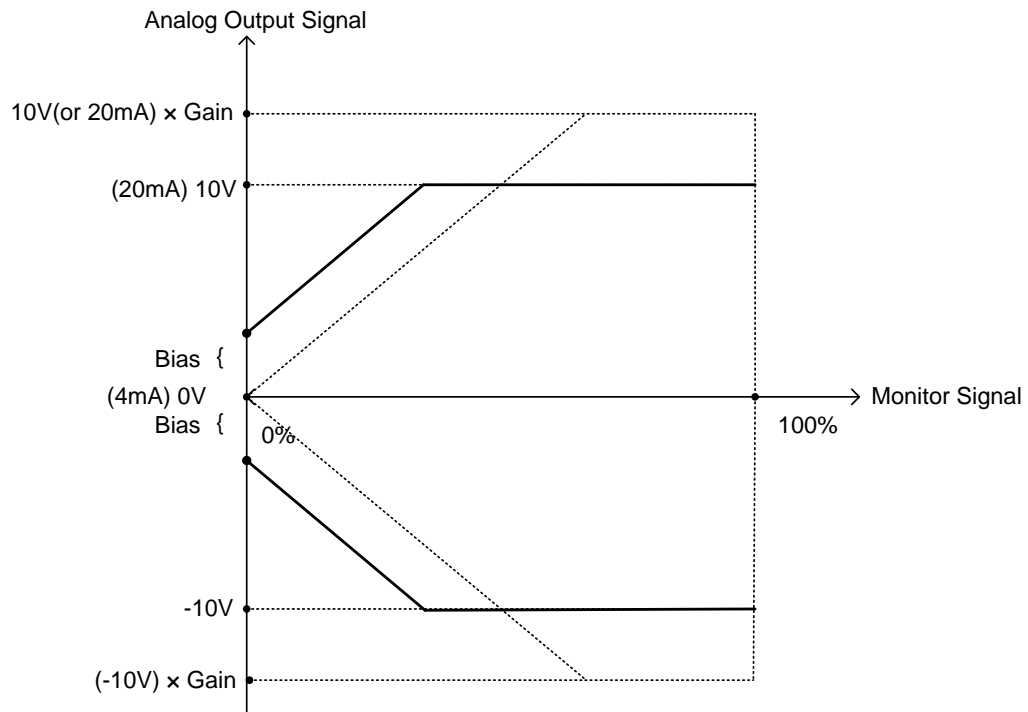

Analog output level adjustment

9. Using PID Control for Constant Flow / Pressure Applications

9.1 What is PID Control?

The PID function in the inverter can be used to maintain a constant process variable such as pressure, flow, temperature by regulating the output frequency (motor speed). A feedback device (transducer) signal is used to compare the actual process variable to a specified setpoint. The difference between the set-point and feedback signal is called the error signal.

The PID control tries to minimize this error to maintain a constant process variable by regulating the output frequency (motor speed).

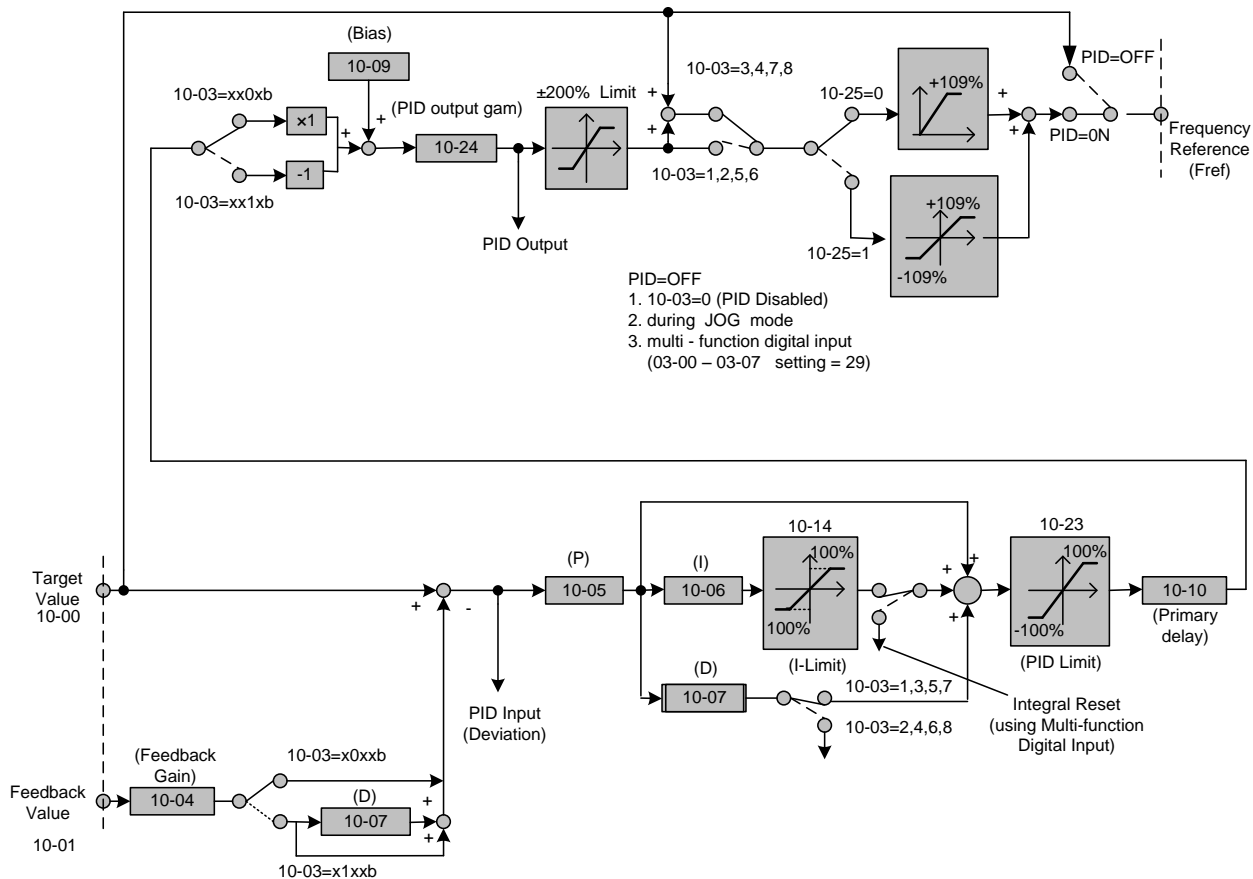

The amplitude of the error can be adjusted with the Proportional Gain parameter 10-05 and is directly related to the output of the PID controller, so the larger gain the larger the output correction.

Example 1:

Gain = 1.0

Set-Point = 80%

Feedback = 78%

Error = Set-point - Feedback = 2%

Control Error = Gain x Error = 2%

Example 2:

Gain = 2.0

Set-Point = 80%

Feedback = 78%

Error = Set-point - Feedback = 2%

Control Error = Gain x Error = 4%

Please note that an excessive gain can make the system unstable and oscillation may occur.

The response time of the system can be adjusted with the Integral Gain set by parameter 10-06. Increasing the Integral Time will make the system less responsive and decreasing the Integral Gain Time will increase response but may result in instability of the total system.

Slowing the system down too much may be unsatisfactory for the process. The end result is that these two parameters in conjunction with the acceleration (00-14) and deceleration (00-15) times are adjusted to achieve optimum performance for a particular application.

For typical fan and pump applications a Proportional Gain (10-05) of 2.0 and an Integral Time (10-06) of 5.0 sec is recommended.

10-03 PID control mode

PID control can be enabled by setting parameter 10-03 to 'xxx1b'

| 10-03 | PID control mode |
|-------|--|
| Range | xxx0b: PID disable xxx1b: PID enable xx0xb: PID positive characteristic xx1xb: PID negative characteristic x0xxb: PID error value of D control x1xxb: PID feedback value of D control 0xxxb: PID output 1xxxb: PID output +target value |

Commonly used PID control modes

0001b: Forward operation: PID operation enabled, motor speeds increases when feedback signal is smaller than set-point (most fan and pump applications)

0011b: Reverse operation: PID operation enabled, motor slows down when feedback signal is smaller than set-point (e.g. level control applications)

To set parameter 10-03:

- After power-up press the **DSP/FUN** key
- Select **10 PID Control**
- Press **READ/ ENTER** key
- Select parameter -03 with the **UP/DOWN ▲** and **▼** keys and press the **READ/ ENTER** key.

Important: To use the PID function parameter 00-05 (Main Frequency Command Source Selection) has to be set to 5 for PID reference.

9.2 Connect Transducer Feedback Signal (10-01)

The PID function in the inverter

Depending on the type of feedback transducer used, the inverter can be setup for either 0-10V or a 4-20mA feedback transducer.

Feedback Signal 4 – 20mA (10-01 = 2) – SW2 = I

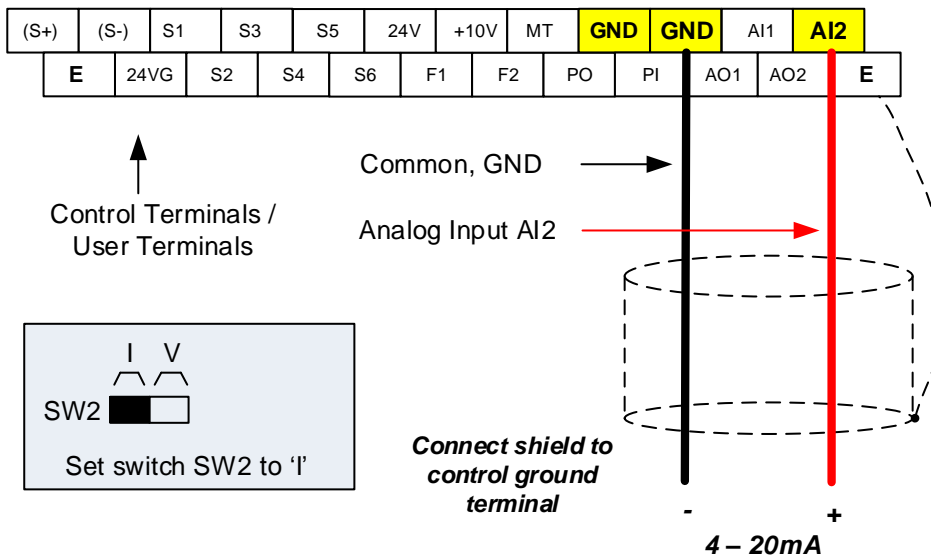

Feedback Signal 0 – 10V (10-01 = 1) – SW2 = V

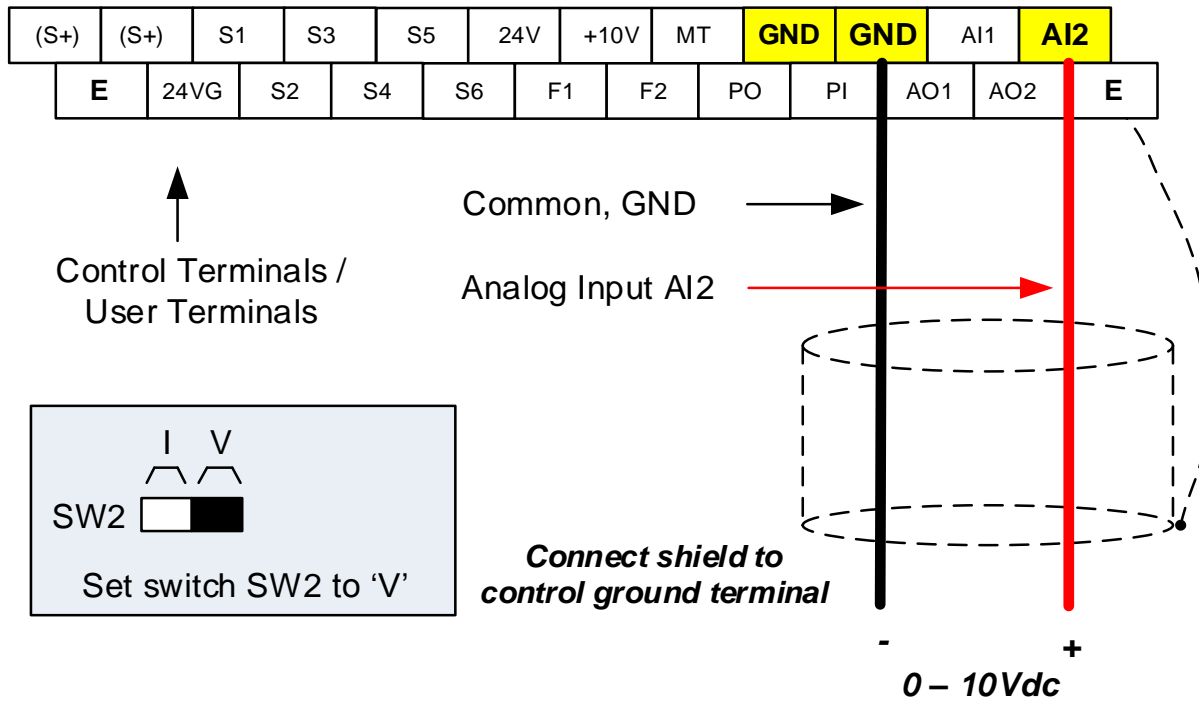

9.3 Engineering Units

The PID setpoint scaling can be selected with parameter 16-03 and 16-04.

Example: 0 – 200.0 PSI Setpoint, set 16-03 to 12000 (1 decimal, range 0 – 200) and 16-04 to 2 (PSI).

9.4 Sleep / Wakeup Function

The PID Sleep function can be used to prevent a system from running at low speeds and is frequently used in pumping application. The PID Sleep function is turned on by parameter 10-29 set to 1. The inverter output turns off when the PID output falls below the PID sleep level (10-17) for the time specified in the PID sleep delay time parameter (10-18).

The inverter wakes up from a sleep condition when the PID output (Reference frequency) rises above the PID wake-up frequency (10-19) for the time specified in the PID wake-up delay time (10-20).

10-29 =0: PID Sleep function is disabled.

10-29 =1: PID sleep operation is based on parameters of 10-17 and 10-18.

10-29 =2: PID sleep mode is enabled by multi-function digital input

Refer to figure 4.3.74 (a) and (b) for PID sleep / wakeup operation.

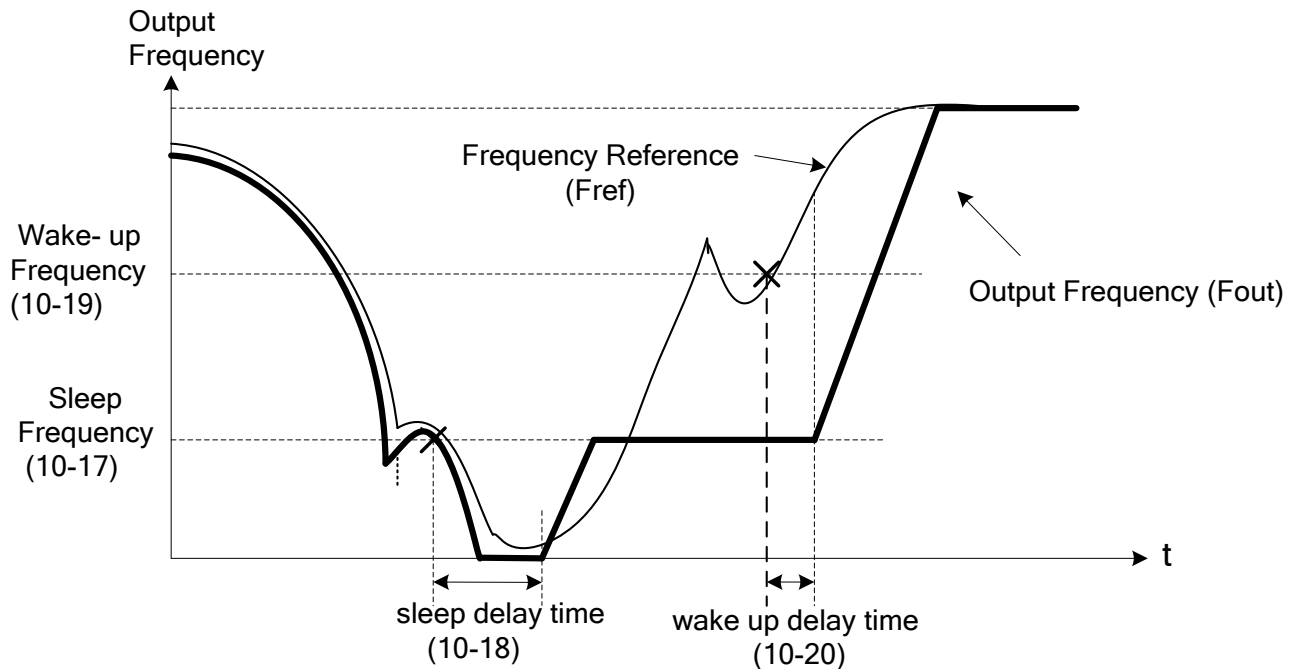
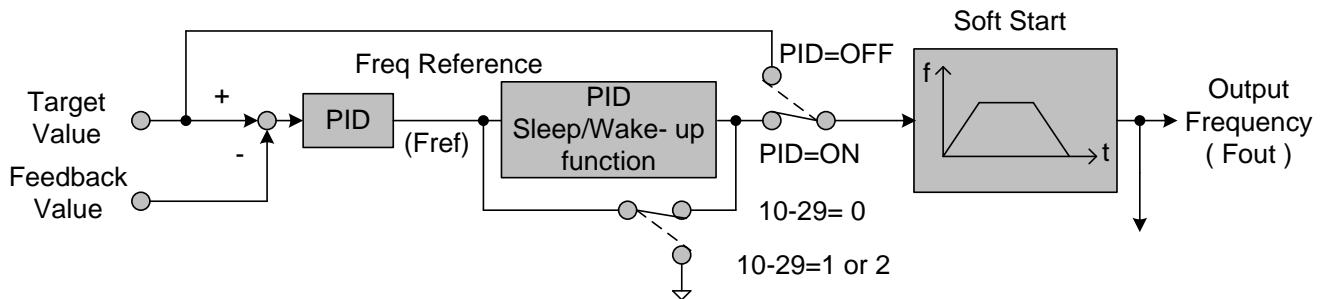

PID Sleep Function

10. Troubleshooting and Fault Diagnostics

10.1 General

Inverter fault detection and early warning / self-diagnosis function. When the inverter detects a fault, a fault message is displayed on the keypad. The fault contact output energizes and the motor will coast to stop (The stop method can be selected for specific faults).

When the inverter detects a warning / self-diagnostics error, the digital operator will display a warning or self-diagnostic code, the fault output does not energize in this case. Once the warning is removed, the system will automatically return to its original state.

10.2 Fault Detection Function



When a fault occurs, please refer to Table 10.2.1 for possible causes and take appropriate measures.













Use one of the following methods to restart:

1. Set one of multi-function digital input terminals (03-00, 03-07) to 17 (Fault reset); activate input
2. Press the reset button on the keypad.
3. Power down inverter wait until keypad goes blank and power-up the inverter again.

When a fault occurs, the fault message is stored in the fault history (see group 12 parameters).



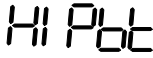
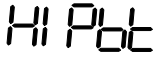



Table 10.2.1 Fault information and possible solutions

| LED display | Description | Cause | Possible solutions |
|---|--|--|---|
| <p>OC over current</p>  | <p>The inverter output current exceeds the overcurrent level (200% of the inverter rated current).</p> | <ul style="list-style-type: none"> • Acceleration / Deceleration time is too short. • Contactor at the inverter output side. • A special motor or applicable capacity is greater than the inverter rated value. • Short circuit or ground fault. | <ul style="list-style-type: none"> • Extend acceleration / deceleration time. • Check the motor wiring. • Disconnect motor and try running inverter. |
| | | | |
| <p>SC short circuit</p>  | <p>Inverter output short circuit or ground fault.</p> | <ul style="list-style-type: none"> • Short circuit or ground fault (08-23 = 1). • Motor damaged (insulation). • Wire damage or deterioration. | <ul style="list-style-type: none"> • Check the motor wiring. • Disconnect motor and try running inverter. |
| | | | |
| <p>GF Ground fault</p>  | <p>The current to ground exceeds 50% of the inverter rated output current (08-23 = 1, GF function is enabled).</p> | <ul style="list-style-type: none"> • Motor damaged (insulation). • Wire damage or deterioration. • Inverter DCCT sensors defect. | <ul style="list-style-type: none"> • Replace motor. • Check the motor wiring. • Disconnect motor and try running inverter. • Check resistance between cables and ground. • Reduce carrier frequency. |
| | | | |

| LED display | Description | Cause | Possible solutions |
|---|--|---|--|
| OV Over voltage  | DC bus voltage exceeds the OV detection level: 410Vdc: 230V class 20Vdc: 460V class (For 440V class, if input voltage 01-14 is set lower than 460V, the OV detection value will be decreased to 700Vdc). | <ul style="list-style-type: none"> Deceleration time set too short, resulting in regenerative energy flowing back from motor to the inverter. The inverter input voltage is too high. Use of power factor correction capacitors. Excessive braking load. Braking transistor or resistor defective. Speed search parameters set incorrectly. | <ul style="list-style-type: none"> Increase deceleration time Reduce input voltage to comply with the input voltage requirements or install an AC line reactor to lower the input voltage. Remove the power factor correction capacitor. Use dynamic braking unit. Replace braking transistor or resistor. Adjust speed search parameters. |
|  | | | |
| UV Under voltage  | DC bus voltage is lower than the UV detection level or the pre-charge contactor is not active while the inverter is running. 190Vdc: 230V class; 380Vdc: 460V class (The detection value can be adjusted by 07-13). | <ul style="list-style-type: none"> The input voltage is too low. Input phase loss. Acceleration time set too short. Input voltage fluctuation. Pre-charge contactor damaged. DC bus voltage feedback signal value not correct. | <ul style="list-style-type: none"> Check the input voltage. Check input wiring. Increase acceleration time. Check power source Replace pre-charge contactor Replace control board or complete inverter. |
|  | | | |
| IPL input phase loss  | Phase loss at the input side of the inverter or input voltage imbalance, active when 08-09 = 1 (enabled). | <ul style="list-style-type: none"> Wiring loose in inverter input terminal. Momentary power loss. Input voltage imbalance. | <ul style="list-style-type: none"> Check input wiring / faster screws. Check power supply. |
|  | | | |
| OPL output phase loss  | Phase loss at the output side of the inverter, active when 08-10 = 1 (enabled). | <ul style="list-style-type: none"> Wiring loose in inverter output terminal. Motor rated current is less than 10% of the inverter rated current. | <ul style="list-style-type: none"> Check output wiring / faster screws. Check motor & inverter rating. |
|  | | | |
| OH1 Heatsink overheat  | The temperature of the heat sink is too high. Note: when OH1 fault occurs three times within five minutes, it is required to wait 10 minutes before resetting the fault. | <ul style="list-style-type: none"> Ambient temperature too high. cooling fan failed Carrier frequency set too high. Load too heavy. | <ul style="list-style-type: none"> Install fan or AC to cool surroundings. Replace cooling fan. Reduce carrier frequency. Reduce load / Measure output current |
|  | | | |
| OL1 Motor overload  | Internal motor overload protection tripped, active when protection curve 08-05 = xxx1. | <ul style="list-style-type: none"> Voltage setting V/F mode too high, resulting in over-excitation of the motor. Motor rated current (02-01) set incorrectly. Load too heavy. | <ul style="list-style-type: none"> Check V/f curve. Check motor rated current Check and reduce motor load, check and operation duty cycle. |
|  | | | |

| LED display | Description | Cause | Possible solutions |
|--|---|--|--|
| OL2 Inverter overload | Inverter thermal overload protection tripped. | | <ul style="list-style-type: none"> • Check V/f curve. • Replace inverter with larger rating. • Check and reduce motor load, check and operation duty cycle. |
| OL2 | If an inverter overload occurs 4 times in five minutes, it is required to wait 4 minutes before resetting the fault. | <ul style="list-style-type: none"> • Voltage setting V/F mode too high, resulting in over-excitation of the motor. • Inverter rating too small. • Load too heavy. | |
| OT Over torque detection | Inverter output torque is higher than 08-15 (over torque detection level) for the time specified in 08-16. Parameter 08-14 = 0 to activate. | <ul style="list-style-type: none"> • Load too heavy. | <ul style="list-style-type: none"> • Check over torque detection parameters (08-15 / 08-16). • Check and reduce motor load, check and operation duty cycle. |
| OT | | | |
| UT Under torque detection | Inverter output torque is lower than 08-19 (under torque detection level) for the time specified in 08-20. Parameter 08-18 = 0 to activate. | <ul style="list-style-type: none"> • Sudden drop in load. • Belt break. | <ul style="list-style-type: none"> • Check under torque detection parameters (08-19 / 08-20). • Check load / application. |
| ut | | | |
| CE communicati on error | No Modbus communication received in for the time specified in 09-06 (communication error detection time). Active when 09-07(= 0 to 2). | <ul style="list-style-type: none"> • Connection lost or wire broken. • Host stopped communicating. | <ul style="list-style-type: none"> • Check connection • Check host computer / software. |
| CE | | | |
| FB PID feedback loss | PID feedback signal falls below level specified in 10-12 (PID feedback loss detection level) for the time specified in 10-13 (Feedback loss detection time). Active when parameter (10-11 = 2). | <ul style="list-style-type: none"> • Feedback signal wire broken • Feedback sensor broken. | <ul style="list-style-type: none"> • Check feedback wiring • Replace feedback sensor. |
| Fb | | | |
| STO Safety switch | Inverter safety switches open. | <ul style="list-style-type: none"> • Terminal board Input F1 and F2 are not connected • 08-30 is set to 1: Coast to stop and digital input (58) is active. | <ul style="list-style-type: none"> • Check F1 and F2 connection |
| STO | | | |

| LED display | Description | Possible causes | Corrective action |
|---|---|---|---|
| DEV Speed deviation 551 | Inverter safety switches open. | <ul style="list-style-type: none"> When 08-30 is set to 0: Deceleration to stop, and digital input (58) is active. | <ul style="list-style-type: none"> Check if digital terminal (58) is active. |
| EF1 External fault (S1) EF1 | External fault (Terminal S1) Active when 03-00= 25, and Inverter external fault selection 08-24=0 or 1. | <ul style="list-style-type: none"> Multifunction digital input external fault active. | <ul style="list-style-type: none"> Multi-function input function set incorrectly. Check wiring |
| EF2 External fault (S2) EF2 | External fault (Terminal S2) Active when 03-01= 25, and Inverter external fault selection 08-24=0 or 1. | | |
| EF3 External fault (S3) EF3 | External fault (Terminal S3) Active when 03-02= 25, and Inverter external fault selection 08-24=0 or 1. | | |
| EF4 External fault (S4) EF4 | External fault (Terminal S4) Active when 03-03= 25, and Inverter external fault selection 08-24=0 or 1. | | |
| EF5 External fault (S5) EF5 | External fault (Terminal S5) Active when 03-04= 25, and Inverter external fault selection 08-24=0 or 1. | | |
| EF6 External fault (S6) EF6 | External fault (Terminal S6) Active when 03-05= 25, and Inverter external fault selection 08-24=0 or 1. | | |
| CF07 Motor control fault CF07 | Motor control fault | | |
| FU fuse open Fu | DC bus fuse blown DC fuse (Models 230V 50HP and above, 460V 75HP and above) open circuit. | <ul style="list-style-type: none"> IGBT damaged. Short circuit output terminals. | <ul style="list-style-type: none"> Check IGBTs Check for short circuit at inverter output. Replace inverter. |

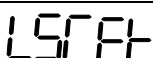
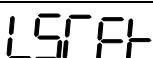
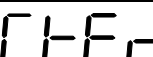
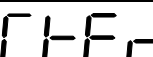
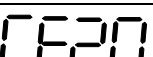
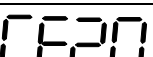
| LED display | Description | Possible causes | Corrective action |
|--|---|---|--|
| LOPBT Low flow fault  | Low flow fault | <ul style="list-style-type: none"> The feedback signal is disconnected. Feedback value is lower than minimum flow limit. | <ul style="list-style-type: none"> Check feedback signal connection. Check if feedback value is lower than minimum flow limit (23-51). |
|  | | | |
| HIPBT High flow fault  | High flow fault | <ul style="list-style-type: none"> Feedback value is greater than maximum flow value. | <ul style="list-style-type: none"> Check feedback value Check if feedback value is lower than maximum flow limit (23-48). |
|  | | | |
| LPBFT Low pressure fault  | Low pressure fault | <ul style="list-style-type: none"> The feedback signal is not connected. Feedback value is lower than minimum feedback value. | <ul style="list-style-type: none"> Check feedback signal connection. Check if feedback value is lower than minimum limit (23-15). |
|  | | | |
| OPBFT High pressure fault  | High pressure fault | <ul style="list-style-type: none"> Feedback value is greater than maximum feedback value. | <ul style="list-style-type: none"> Check feedback signal connection. Check if feedback value is greater than maximum limit (23-12). |
|  | | | |
| LSCFT Low suction fault  | Low suction fault | <ul style="list-style-type: none"> Low water flow or not enough suction Difference between setpoint and feedback value is too high. Output current is too low. | <ul style="list-style-type: none"> Check water flow Check feedback value Check output current |
|  | | | |
| CF00 Operator Communication Error LCD display only* | LCD keypad data communication fault | <ul style="list-style-type: none"> No communication between LCD keypad and inverter for more than 5 seconds after power up. | <ul style="list-style-type: none"> Disconnect the keypad and then reconnect. Replace the control board Check keypad cable |
| LCD display only* | | | |
| CF01 Operator Communication Error 2 LCD display only* | LCD keypad data communication fault | <ul style="list-style-type: none"> Communication errors between LCD keypad and inverter for more than 2 seconds. | <ul style="list-style-type: none"> Disconnect the keypad and then reconnect. Replace the control board Check keypad cable |
| LCD display only* | | | |
| CT Fault  | Input voltage fault | <ul style="list-style-type: none"> Abnormal input voltage, too much noise or malfunctioning control board. | <ul style="list-style-type: none"> Check input voltage signal and the voltage on the control board. |
|  | | | |
| CF20 Double Communication Error  | Both Profibus and Modbus communication selected | <ul style="list-style-type: none"> Two communication protocols are active simultaneously. | <ul style="list-style-type: none"> Select only one communication protocol. |
|  | | | |

10.3 Warning / Self-diagnosis Detection Function

When the inverter detects a warning, the keypad displays a warning code (flash).

Note: The fault contact output does not energize on a warning and the inverter continues operation. When the warning is no longer active the keypad will return to its original state.

When the inverter detected a programming error (for example two parameters contradict each other or are set to an invalid setting), the keypad displays a self-diagnostics code.







Note: The fault contact output does not energize on a self-diagnostics error. While a self-diagnostics code is active the inverter does not accept a run command until the programming error is corrected.







Note: When a warning or self-diagnostic error is active the warning or error code will flash on the keypad. When the RESET key is pressed, the warning message (flash) disappears and returns after 5 sec. If the warning or self-diagnostic error still exists.







Refer to Table 10.3.1 for an overview, cause and corrective action for inverter warnings and self-diagnostic errors.





Table 10.3.1 warning / self-diagnosis and corrective actions







| LED display | Description | Possible causes | Corrective action |
|---|---|---|--|
| OV (flash) Over voltage |  DC bus voltage exceeds the OV detection level: 410Vdc: 230V class 820Vdc: 460V class (for 440V class, if input voltage 01-14 is set lower than 460V, the OV detection value will be decreased to 700Vdc) | <ul style="list-style-type: none"> Deceleration time set too short, resulting in regenerative energy flowing back from motor to the inverter. The inverter input voltage is too high. Use of power factor correction capacitors. Excessive braking load. Braking transistor or resistor defective. Speed search parameters set incorrectly. | <ul style="list-style-type: none"> Increase deceleration time Reduce input voltage to comply with the input voltage requirements or install an AC line reactor to lower the input voltage. Remove the power factor correction capacitor. Use dynamic braking unit. Replace braking transistor or resistor. Adjust speed search parameters. |
| UV (flash) under voltage | | | |
| OH2 (flash) Inverter over heating warning | Inverter overheat warning Multi-function digital input set to 32. (Terminal S1 ~ S8) Active when 03-00 ~ 03-07 = 31). | <ul style="list-style-type: none"> Multifunction digital input overheat warning active. | <ul style="list-style-type: none"> Multi-function input function set incorrectly. Check wiring |







| LED display | Description | Possible causes | Corrective action |
|---|---|--|---|
|  | | | |
| OT (flash) over torque detection | Inverter output torque is higher than 08-15 (over torque detection level) for the time specified in 08-16. Parameter 08-14 = 0 to activate. | <ul style="list-style-type: none"> • Load too heavy. | <ul style="list-style-type: none"> • Check over torque detection parameters (08-15 / 08-16). • Check and reduce motor load, check and operation duty cycle. |
|  | | | |
| UT (flash) under torque detection | Inverter output torque is lower than 08-19 (under torque detection level) for the time specified in 08-20. Parameter 08-18 = 0 to activate. | <ul style="list-style-type: none"> • Sudden drop in load. • Belt break. | <ul style="list-style-type: none"> • Check under torque detection parameters (08-19 / 08-20). • Check load / application. |
|  | | | |
| bb1 (flash) External baseblock | External base block (Terminal S1) | <ul style="list-style-type: none"> • Multifunction digital input external baseblock active. | <ul style="list-style-type: none"> • Multi-function input function set incorrectly. • Check wiring |
|  | | | |
| bb2 (flash) External baseblock | External base block (Terminal S2) | | |
|  | | | |
| Bb3 (flash) External baseblock | External base block (Terminal S3) | | |
|  | | | |
| Bb4 (flash) External baseblock | External base block (Terminal S4) | | |
|  | | | |

| LED display | Description | Possible causes | Corrective action |
|---|--|--|---|
| bb5 (flash) External baseblock  | External base block (Terminal S5) | | |
| bb6 (flash) External baseblock  | External base block (Terminal S6) | <ul style="list-style-type: none"> • Multifunction digital input external baseblock active. | <ul style="list-style-type: none"> • Multi-function input function set incorrectly. • Check wiring |
| OL1 Motor overload  | Internal motor overload protection tripped, active when protection curve 08-05 = xxx1. | <ul style="list-style-type: none"> • Voltage setting V/F mode too high, resulting in over-excitation of the motor. • Motor rated current (02-01) set incorrectly. • Load too heavy. | <ul style="list-style-type: none"> • Check V/f curve. • Check motor rated current • Check and reduce motor load, check and operation duty cycle. |
| OL2 Inverter overload  | Inverter thermal overload protection tripped. If an inverter overload occurs 4 times in five minutes, it is required to wait 4 minutes before resetting the fault. | <ul style="list-style-type: none"> • Voltage setting V/F mode too high, resulting in over-excitation of the motor. • Inverter rating too small. • Load too heavy. | <ul style="list-style-type: none"> • Check V/f curve. • Replace inverter with larger rating. • Check and reduce motor load, check and operation duty cycle |
| CE (flash) communication error  | No Modbus communication received for 2 sec. Active when 09-07=3. | <ul style="list-style-type: none"> • Connection lost or wire broken. • Host stopped communicating. | <ul style="list-style-type: none"> • Check connection • Check host computer / software. |
| CLB over current protection level B  | Inverter current reaches the current protection level B. | <ul style="list-style-type: none"> • Inverter current too high. • Load too heavy. | <ul style="list-style-type: none"> • Check load and duty cycle operation. |

| LED display | Description | Possible causes | Corrective action |
|---|---|--|--|
| Retry (flash) retry  | Automatic reset activated, warning is displayed until restart delay time set (07-01) expires. | <ul style="list-style-type: none"> Parameter 07-01 set to a value greater than 0. Parameter 07-02 set to a value greater than 0. | <ul style="list-style-type: none"> Warning disappears after automatic reset. |
| F1 (flash) External fault (S1)  | External fault (Terminal S1) Active when 03-00=25, and Inverter external fault selection 08-24=2. | <ul style="list-style-type: none"> Multifunction digital input external fault active and parameter 08-24 = 2 for operation to continue. | <ul style="list-style-type: none"> Multi-function input function set incorrectly. Check wiring Multi-function input function set incorrectly. Check wiring |
| EF2 (flash) External fault (S2)  | External fault (Terminal S2) Active when 03-01=25, and Inverter external fault selection 08-24=2. | | |
| EF3 (flash) External fault (S3)  | External fault (Terminal S3) Active when 03-02=25, and Inverter external fault selection 08-24=2. | | |
| EF4 (flash) External fault (S4)  | External fault (Terminal S4) Active when 03-03=25, and Inverter external fault selection 08-24=2. | | |
| EF5 (flash) External fault (S5)  | External fault (Terminal S5) Active when 03-04=25, and Inverter external fault selection 08-24=2. | | |
| EF6 (flash) External fault (S6)  | External fault (Terminal S6) Active when 03-05=25, and Inverter external fault selection 08-24=2. | | |

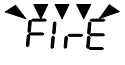
| LED display | Description | Possible causes | Corrective action |
|---|--|---|---|
| EF9 (flash) error of forward/reve rsal rotation  | Forward run and reverse run are active within 0.5 sec of each other. Stop method set by parameter 07-09. | <ul style="list-style-type: none"> • Forward run and reverse run active (see 2-wire control). | <ul style="list-style-type: none"> • Check run command wiring |
| SE01 Rang setting error  | Parameter setting falls outside the allowed range. | <ul style="list-style-type: none"> • Some parameter ranges are determined by other inverter parameters which could cause an out of range warning when the dependency parameter is adjusted. Example: 02-00 > 02-01, 02-20 > 02-21, 00-12 > 00-13 etc...). | <ul style="list-style-type: none"> • Check parameter setting. |
| SE02 Digital input terminal error  | Multi-function input setting error. | <ul style="list-style-type: none"> • Multi-function digital input terminals (03-00 to 03-07) are set to the same function (not including ext. fault and not used.) or ①UP/DOWN commands are not set at the same time(they must be used together). ②UP/DOWN commands (08 and 09) and ACC/DEC commands (11) are set at the same time. ③Speed search 1(19, maximum frequency) and Speed search 2 (34, from the set frequency) are set at the same time. | <ul style="list-style-type: none"> • Check multi-function input setting. |
| SE03 V/f curve error  | V/f curve setting error. | <ul style="list-style-type: none"> • V/F curve setting error. ① 01-02 > 01-12 > 01-06 >01-08; • (Fmax) (Fbase) (Fmid1) (Fmin) ②01-16 > 01-24 > 01-20 > 01-22; • (Fmax2) (Fbase2)(Fmid1) (Fmin2) | <ul style="list-style-type: none"> • Check V/F parameters |
| SE05 PID selection error  | PID selection error. | <ul style="list-style-type: none"> • 10-00 and 10-01are set to the same analog input 1 (AI1) or 2 (AI2) | <ul style="list-style-type: none"> • Check parameters 10-00 and 10-01. |

| LED display | Description | Possible causes | Corrective action |
|---|---|--|---|
| HPErr Model selection error  | Inverter capacity setting error: Inverter capacity setting 13-00 does not match the rated voltage. | <ul style="list-style-type: none"> • Inverter capacity setting does not match voltage class (13-00). | <ul style="list-style-type: none"> • Check inverter capacity setting 13-00. |
| SE09 PI setting error  | | | |
| FB (flash) PID feedback breaking  | PID feedback signal falls below level specified in 10-12 (PID feedback loss detection level) for the time specified in 10-13 (Feedback loss detection time). Active when parameter (10-11 = 1). | <ul style="list-style-type: none"> • Feedback signal wire broken • Feedback sensor broken. | <ul style="list-style-type: none"> • Check feedback wiring • Replace feedback sensor. |
| USP (flash) Unattended Start Protection  | | | |
| LFPB Low flow error  | Low flow error | <ul style="list-style-type: none"> • The feedback signal is not connected. • Due to HVAC feedback value is lower than limit of minimum flow. | <ul style="list-style-type: none"> • Check feedback signal is correct and with right connection. • Check if feedback value is lower than limit of minimum flow. |
| HFPB High flow error  | | | |
| LPBFT Low pressure error  | Low pressure error | <ul style="list-style-type: none"> • The feedback signal is not connected. • Due to feedback value of pump pressure is lower than limit of minimum flow. | <ul style="list-style-type: none"> • Check feedback signal is correct and with connection. • Check if feedback value of pressure is lower than limit of minimum pressure. |

| LED display | Description | Possible causes | Corrective action |
|---|---|--|--|
| OPBFT High pressure error | High pressure error | <ul style="list-style-type: none"> Due to feedback value of pump pressure is lower than limit of maximum flow. | <ul style="list-style-type: none"> Check feedback signal is correct. Check if feedback value of pressure is lower than limit of maximum pressure. |
|  | | | |
| LSCFT Low suction error | Inadequate suction error | <ul style="list-style-type: none"> Insufficient water of supply tank leads to insufficient suction. PID difference is higher than its level or current is lower than output current level. | <ul style="list-style-type: none"> Check if water of supply tank is enough, and water supply is regular. Check PID difference is higher than its level or current is lower than output current level |
|  | | | |
| FIRE Fire override mode | Fire override mode | <ul style="list-style-type: none"> Fire override mode is active | <ul style="list-style-type: none"> None (Fire override mode is not a kind of warning). |
|  | | | |
| SE10 PUMP/HVAC Setting error | PUMP/HVAC settings of inverter error | <ul style="list-style-type: none"> PUMP selection of inverter (23-02)> (23-03). HVAC selection of inverter (23-46)> (23-47). | <ul style="list-style-type: none"> Check pump selection of inverter (23-02) and (23-03) settings. Check HVAC selection of inverter (23-02) and (23-03) settings. |
|  | | | |
| COPUP PUMP communication breaking error | Breaking error of multiple pumps communication | <ul style="list-style-type: none"> Communication breaking or disconnection of pump cascade control. | <ul style="list-style-type: none"> Check if it has setting issue or is not properly connected. |
|  | | | |
| Parameter Setting Error | Parameter setting error | <ul style="list-style-type: none"> Error of Parameter setting occurs. | <ul style="list-style-type: none"> Refer to the instruction manual or this parameter is selected to be disabled. |
|  | | | |
| Warning of Direct Start | When 07-04 is set to 1, the inverter cannot start directly but displays the warning signal. | <ul style="list-style-type: none"> Set the digital input terminal (S1-S6) to run and simultaneously set 07-04=1. | <ul style="list-style-type: none"> Check the digital input terminal and disconnect it. Then reconnect the DI terminal after the setting delay time (07-05) ends. |

10.4 Auto-tuning Error

When a fault occurs during auto-tuning of a standard AC motor, the display will show the “AtErr” fault and the motor stops. The fault information is displayed in parameter 17-11.

Note: The fault contact output does not energize with an auto-tuning fault. Refer to Table 10.4.1, for fault information during tuning, cause and corrective action.

Table 10.4.1 Auto-tuning fault and corrective actions

| Error | Description | Cause | Corrective action |
|-------|--|---|--|
| 01 | Motor data input error. | <ul style="list-style-type: none"> Motor Input data error during auto-tuning. Inverter output current does not match motor rated current. | <ul style="list-style-type: none"> Check the motor tuning data (17-00 to 17-09). Check inverter capacity |
| 02 | Motor lead to lead resistance R1 tuning error. | <ul style="list-style-type: none"> Auto-tuning is not completed within the specified time Auto-tuning results fall outside parameter setting range. Motor rated current exceeded. Motor was disconnected. | <ul style="list-style-type: none"> Check the motor tuning data (17-00 to 17-09). Check motor connection. Disconnect motor load. Check inverter current detection circuit and DCCTs. Check motor installation. |
| 03 | Motor leakage inductance tuning error. | | |
| 04 | Motor rotor resistance R2 tuning error. | | |
| 05 | Motor mutual inductance Lm tuning error. | | |
| 07 | Deadtime compensation detection error | | |
| 06 | Motor encoder error | <ul style="list-style-type: none"> PG feedback noise | <ul style="list-style-type: none"> Check motor rated current. Check PG card grounding. |
| 08 | Motor acceleration error (Rotational type auto-tuning only). | <ul style="list-style-type: none"> Motor fails to accelerate in the specified time (00-14= 20sec). | <ul style="list-style-type: none"> Increase acceleration time (00-14). Disconnect motor load. |
| 09 | Other | <ul style="list-style-type: none"> No load current is higher than 70% of the motor rated current. Torque reference exceeds 100%. Errors other than ATE01~ATE08. | <ul style="list-style-type: none"> Check the motor tuning data (17-00 to 17-09). Check motor connection. |

10.5 PM Motor Auto-tuning Error

When a fault occurs during auto-tuning of a PM motor, the display will show the “IPErr” fault and the motor stops. The fault information is displayed in parameter 22-18.

Note: The fault contact output does not energize with an auto-tuning fault. Refer to Table 10.5.1, for fault information during tuning, cause and corrective action.

Table 10.5.1 Auto-tuning fault and corrective actions for PM motor

| Error | Description | Cause | Corrective action |
|---------|--|---|---|
| 01 | Magnetic pole alignment tuning failure (static). | <ul style="list-style-type: none"> Inverter output current does not match motor current. | <ul style="list-style-type: none"> Check the motor tuning data (22-02). Check inverter capacity |
| 02 - 04 | Reserved | | |
| 05 | Circuit tuning time out. | <ul style="list-style-type: none"> System abnormality during circuit tuning. | <ul style="list-style-type: none"> Check for active protection functions preventing auto-tuning. |
| 06 | Encoder error | <ul style="list-style-type: none"> PG feedback noise | <ul style="list-style-type: none"> Check motor rated current. Check PG card grounding. |
| 07 | Other motor tuning errors. | <ul style="list-style-type: none"> Other tuning errors. | <ul style="list-style-type: none"> Check the motor tuning data (22-02). Check motor connection. |
| 08 | Reserved | | |
| 09 | Current out of range during circuit tuning. | <ul style="list-style-type: none"> Inverter output current does not match motor current. | <ul style="list-style-type: none"> Check the motor tuning data (22-02). Check inverter capacity |
| 10 | Reserved | | |
| 11 | Parameter tuning time out. | <ul style="list-style-type: none"> Error relationship between voltage and current. | <ul style="list-style-type: none"> Check if value for parameter 22-11 is set too low, value cannot exceed 100% of the inverter rated current. Check motor connection. |

11. Inverter Peripheral devices and Options

11.1 Braking Resistors and Braking Units

Inverters ratings 230V 5 ~ 30HP / 460V 5 ~ 40HP *IP20) have a built-in braking transistor. For applications requiring more braking torque an external braking resistor can be connected to terminals B1 / P and B2; for inverter ratings above 230V 40HP / 460V 50HP (IP20), an external braking unit (connected to ⊕ - ⊖ of the inverter) and a braking resistor (connected to two ends of the detection module B-P0) is required.

Table 11.1 List of braking resistors and braking units (IP20)

| Inverter | | | Braking unit | | Braking resistor | | | | Braking torque (Peak / Continues) | Minimum resistance | |
|------------|-----|-------------------|--------------|---------|------------------|------------------------|----------|-------------------------------|--------------------------------------|--------------------|------|
| V | HP | Rated Current (A) | Model | Qty Req | Part Number | Resistor specification | Qty Req. | Resistor dimensions (L*W*H)mm | | (Ω) | (W) |
| 3φ 230V | 5 | 14.5 | - | - | JNBR-390W40 | 390W/40Ω | 1 | 395*34*78 | 126%,10%ED | 25 | 680 |
| | 7.5 | 21 | - | - | JNBR-520W30 | 520W/30Ω | 1 | 400*40*100 | 114%,10%ED | 21 | 800 |
| | 10 | 30 | - | - | JNBR-780W20 | 780W/20Ω | 1 | 400*40*100 | 126%,10%ED | 18 | 900 |
| | 15 | 40 | - | - | JNBR-2R4KW13R6 | 2400W/13.6Ω | 1 | 535*50*110 (*2 pcs) | 124%, 10%ED | 11 | 1500 |
| | 20 | 56 | - | - | JNBR-3KW10 | 3000W/10Ω | 1 | 615*50*110 (*2 pcs) | 126%, 10%ED | 9.5 | 1800 |
| | 25 | 69 | - | - | JNBR-4R8KW8 | 4800W/8Ω | 1 | 535*50*110 (*4 pcs) | 126%, 10%ED | 7.2 | 2400 |
| | 30 | 79 | - | - | JNBR-4R8KW6R8 | 4800W/6.8Ω | 1 | 535*50*110 (*4 pcs) | 124%, 10%ED | 6.5 | 2400 |
| | 40 | 110 | JNTBU-230 | 2 | JNBR-3KW10 | 3000W/10Ω | 2 | 615*50*110 (*4 pcs) | 126%, 10%ED | 2.7 | 3000 |
| | 50 | 138 | JNTBU-230 | 2 | JNBR-3KW10 | 3000W/10Ω | 2 | 615*50*110 (*4 pcs) | 105%, 10%ED | 2.7 | 3000 |
| | 60 | 169 | JNTBU-230 | 2 | JNBR-4R8KW6R8 | 4800W/6.8Ω | 2 | 535*50*110 (*8 pcs) | 124%, 10%ED | *note1 | |
| | 75 | 200 | JNTBU-230 | 3 | JNBR-4R8KW8 | 4800W/8Ω | 3 | 535*50*110 (*12 pcs) | 124%, 10%ED | *note1 | |
| | 100 | 250 | JNTBU-230 | 3 | JNBR-4R8KW6R8 | 4800W/6.8Ω | 3 | 535*50*110 (*12 pcs) | 116%, 10%ED | *note1 | |
| | 125 | 312 | JNTBU-230 | 4 | JNBR-4R8KW6R8 | 4800W/6.8Ω | 4 | 535*50*110 (*16 pcs) | 119%,10%ED | *note1 | |
| | 150 | 400 | JNTBU-230 | 5 | JNBR-4R8KW6R8 | 4800W/6.8Ω | 4 | 535*50*110 (*16 pcs) | 108%,10%ED | *note1 | |

| Inverter | | | Braking unit | | Braking resistor | | | | Braking torque (Peak / Continues) | Minimum resistance | |
|------------|-----|-------------------|--------------|----------------|------------------|------------------------|-------------------------|-------------------------------|--------------------------------------|--------------------|------|
| V | HP | Rated Current (A) | Model | Qty Req | Part Number | Resistor specification | Qty Req. | Resistor dimensions (L*W*H)mm | | (Ω) | (W) |
| 3φ 460V | 5 | 9.2 | - | - | JNBR-400W150 | 400W/150Ω | 1 | 395*34*78 | 133%, 10%ED | 60 | 1200 |
| | 7.5 | 11.1 | - | - | JNBR-600W130 | 600W/130Ω | 1 | 400*40*100 | 107%, 10%ED | 60 | 1200 |
| | 10 | 17.5 | - | - | JNBR-800W100 | 800W/100Ω | 1 | 535*50*110 | 105%, 10%ED | 43 | 1600 |
| | 15 | 23 | - | - | JNBR-1R6KW50 | 1600W/50Ω | 1 | 615*50*110 | 133%, 10%ED | 43 | 1600 |
| | 20 | 31 | - | - | JNBR-1R5KW40 | 1500W/40Ω | 1 | 615*50*110 | 126%, 10%ED | 39 | 1600 |
| | 25 | 38 | - | - | JNBR-4R8KW32 | 4800W/32Ω | 1 | 535*50*110 (*4 pcs) | 126%, 10%ED | 22 | 3000 |
| | 30 | 44 | - | - | JNBR-4R8KW27R2 | 4800W/27.2Ω | 1 | 535*50*110 (*4 pcs) | 124%, 10%ED | 13.5 | 4800 |
| | 40 | 54 | - | - | JNBR-6KW20 | 6000W/20Ω | 1 | 615*50*110 (*4 pcs) | 124%, 10%ED | 13.5 | 4800 |
| | 50 | 72 | JNTBU-430 | 2 | JNBR-4R8KW32 | 4800W/32Ω | 2 | 535*50*110 (*8 pcs) | 126%, 10%ED | 11 | 3000 |
| | 60 | 88 | JNTBU-430 | 2 | JNBR-4R8KW27R2 | 4800W/27.2Ω | 2 | 535*50*110 (*8 pcs) | 124%, 10%ED | 11 | 3000 |
| | 75 | 103 | JNTBU-430 | 2 | JNBR-6KW20 | 6000W/20Ω | 2 | 615*50*110 (*8 pcs) | 133%, 10%ED | 11 | 3000 |
| | 100 | 145 | JNTBU-430 | 3 | JNBR-4R8KW27R2 | 4800W/27.2Ω | 3 | 535*50*110 (*12 pcs) | 113%, 10%ED | *note1 | |
| | 125 | 165 | JNTBU-430 | 3 | JNBR-6KW20 | 6000W/20Ω | 3 | 615*50*110 (*12 pcs) | 121%, 10%ED | *note1 | |
| | 150 | 208 | JNTBU-430 | 3 | JNBR-6KW20 | 6000W/20Ω | 3 | 615*50*110 (*12 pcs) | 104%, 10%ED | *note1 | |
| | 175 | 250 | JNTBU-430 | 5 | JNBR-4R8KW27R2 | 4800W/27.2Ω | 5 | 535*50*110 (*20 pcs) | 109%, 10%ED | *note1 | |
| 215 | 296 | JNTBU-430 | 6 | JNBR-4R8KW27R2 | 4800W/27.2Ω | 6 | 535*50*110 (*24 pcs) | 107%, 10%ED | *note1 | | |
| 250 | 328 | JNTBU-430 | 5 | JNBR-6KW20 | 6000W/20Ω | 5 | 615*50*110 (*20 pcs) | 105%, 10%ED | *note1 | | |

*1: Minimum resistance is the acceptable minimum value of the braking resistor for a single braking unit.

Note: Keep sufficient space between inverter, braking unit and braking resistor and ensure proper cooling is provided for.

11.2 AC Line Reactors

An AC line reactor can be used for any of the following:

- Capacity of power system is much larger than the inverter rating.
- Inverter mounted close to the power system (in 33ft / 10 meters).
- Reduce harmonic contribution (improve power factor) back to the power line.
- Protect inverter input diode front-end by reducing short-circuit current.
- Minimize overvoltage trips due to voltage transients.

Please select the AC line reactor based on the inverter rating according to the following table.

Table11.2.1 List of AC Line Reactors

| Model | | AC reactor | | |
|------------------|-----------------|------------------|-----------------------|-------------------|
| Voltage | HP | Part Number | Inductance Value (mH) | Rated Current (A) |
| 3 ϕ 230V | 5 | JNACL0P71M15A2 | 0.71mH | 15A |
| | 7.5 | JNACL0P53M20A2 | 0.53mH | 20A |
| | 10 | JNACL0P35M30A2 | 0.35mH | 30A |
| | 15 | JNACL0P265M40A2 | 0.265mH | 40A |
| | 20 | JNACL0P18M60A2 | 0.18mH | 60A |
| | 25 | JNACL0P13M80A2 | 0.13mH | 80A |
| | 30 | JNACL0P12M90A2 | 0.12mH | 90A |
| | 40 | JNACL0P09M120A2 | 0.09mH | 120A |
| | 50 | JNACL0P07M160A2 | 0.07mH | 160A |
| | 60 | JNACL0P05M200A2 | 0.05mH | 200A |
| | 75 | JNACL0P044M240A2 | 0.044mH | 240A |
| | 100 | JNACL0P038M280A2 | 0.038mH | 280A |
| | 125 | JNACL0P026M360A2 | 0.026mH | 360A |
| 3 ϕ 460V | 5/7.5 | JNACL2P2M10A4 | 2.2mH | 10A |
| | 10 | JNACL1P42M15A4 | 1.42mH | 15A |
| | 15 | JNACL1P06M20A4 | 1.06mH | 20A |
| | 20 | JNACL0P7M30A4 | 0.7mH | 30A |
| | 25 | JNACL0P53M40A4 | 0.53mH | 40A |
| | 30 | JNACL0P42M50A4 | 0.42mH | 50A |
| | 40 | JNACL0P36M60A4 | 0.36mH | 60A |
| | 50 | JNACL0P26M80A4 | 0.26mH | 80A |
| | 60 | JNACL0P24M90A4 | 0.24mH | 90A |
| | 75 | JNACL0P18M120A4 | 0.18mH | 120A |
| | 100 | JNACL0P15M150A4 | 0.15mH | 150A |
| | 125 | JNACL0P11M200A4 | 0.11mH | 200A |
| | 150 | JNACL0P09M250A4 | 0.09mH | 250A |
| | 175/215 | JNACL0P06M330A4 | 0.06mH | 330A |
| 250 | JNACL0P05M400A4 | 0.05mH | 400A | |

Note: AC reactors listed in this table can only be used for the inverter input side. Do not connect AC reactor to the inverter output side. Both 230V class 60HP~125HP (IP20) and 460V class 100HP~425HP (IP20) have built-in DC reactors. If required by the application an AC reactor may be added.

11.2.1 AC Line Reactors Dimensions (230V)

1. Standard: In Compliance with JEC-2210 (Ver. 1990)
2. Insulation Level: H Level
3. Phase: 3-phase
4. Voltage: 200~240V
5. Insulation Resistance: below 0.2~1.1KV AC 4000V/1Min
6. Type: MR-DL (for input terminal)
7. Dimensions:

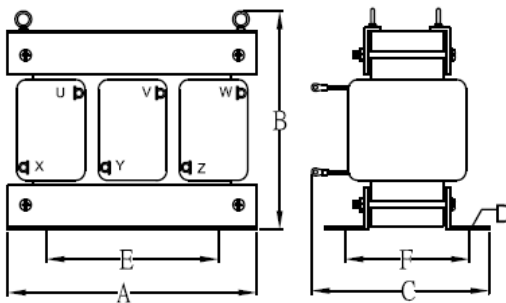

Figure 1

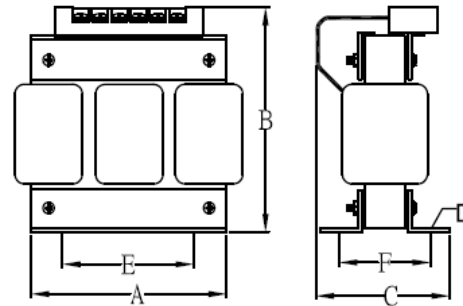

Figure 2

| Voltage (V) | Inductance Value (mH) | Rated Current (A) | Dimensions (mm) | | | | | | Figure | NW (Kg) |
|------------------|-----------------------|-------------------|-----------------|-----|-----|-----|-----|----------|----------|---------|
| | | | A | B | C | D | E | F | | |
| 3 ϕ 230V | 0.71mH | 15A | 150 | 145 | 85 | 6 | 60 | 65 | Figure 2 | 3.5 |
| | 0.53mH | 20A | 150 | 145 | 85 | 6 | 60 | 65 | Figure 2 | 3.5 |
| | 0.35mH | 30A | 150 | 125 | 120 | 6 | 60 | 65 | Figure 1 | 3.5 |
| | 0.265mH | 40A | 150 | 125 | 130 | 6 | 60 | 75 | Figure 1 | 4.5 |
| | 0.18mH | 60A | 150 | 125 | 130 | 6 | 60 | 75 | Figure 1 | 4.5 |
| | 0.13mH | 80A | 180 | 150 | 150 | 6 | 90 | 75 | Figure 1 | 7 |
| | 0.12mH | 90A | 180 | 150 | 150 | 6 | 90 | 75 | Figure 1 | 7 |
| | 0.09mH | 120A | 180 | 150 | 160 | 6 | 90 | 85 | Figure 1 | 8 |
| | 0.07mH | 160A | 230 | 180 | 170 | 10 | 160 | 90 | Figure 1 | 16 |
| | 0.05mH | 200A | 230 | 180 | 180 | 10 | 160 | 100 | Figure 1 | 18 |
| | 0.044mH | 240A | 230 | 180 | 190 | 10 | 160 | 110 | Figure 1 | 23 |
| | 0.038mH | 280A | 230 | 180 | 200 | 10 | 160 | 120 | Figure 1 | 25 |
| 0.026mH | 360A | 280 | 250 | 230 | 10 | 160 | 135 | Figure 1 | 30 | |

11.2.2 AC Line Reactors Dimensions (460V)

1. Standard: In Compliance with JEC-2210 (Ver. 1990)
2. Insulation Level: H Level
3. Phase: 3-phase
4. Voltage: 380~600V
5. Insulation Resistance: below 0.2~1.1KVAC 4000V/1Min
6. Type: MR-DL (for input terminal)
7. Dimensions

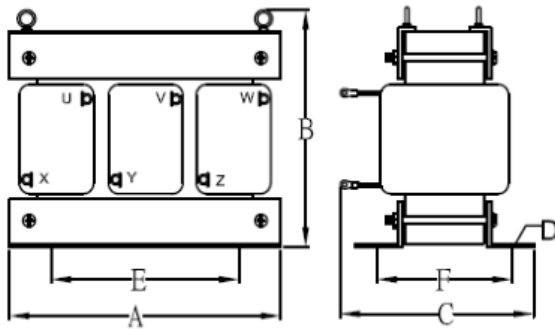

Figure 1

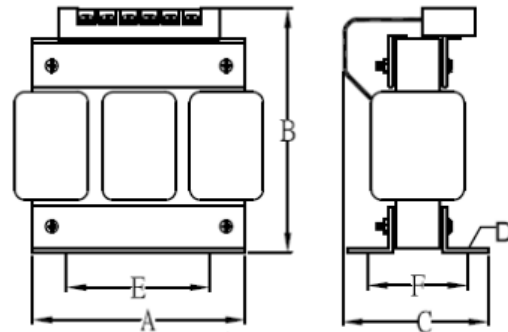

Figure 2

| Voltage (V) | Inductance Value (mH) | Rated Current (A) | Dimensions (mm) | | | | | | Figure | NW (Kg) |
|------------------|-----------------------|-------------------|-----------------|-----|-----|----|-----|-----|----------|---------|
| | | | A | B | C | D | E | F | | |
| 3 ϕ 460V | 2.2mH | 10A | 150 | 145 | 85 | 6 | 60 | 65 | Figure 2 | 3.5 |
| | 1.42mH | 15A | 150 | 145 | 85 | 6 | 60 | 65 | Figure 2 | 3.5 |
| | 1.06mH | 20A | 150 | 145 | 95 | 6 | 60 | 75 | Figure 2 | 4.5 |
| | 0.7mH | 30A | 150 | 125 | 130 | 6 | 60 | 75 | Figure 1 | 4.5 |
| | 0.53mH | 40A | 180 | 150 | 150 | 6 | 90 | 75 | Figure 1 | 7 |
| | 0.42mH | 50A | 180 | 150 | 160 | 6 | 90 | 85 | Figure 1 | 8 |
| | 0.36mH | 60A | 180 | 150 | 160 | 6 | 90 | 85 | Figure 1 | 8.5 |
| | 0.26mH | 80A | 230 | 190 | 170 | 8 | 160 | 85 | Figure 1 | 12 |
| | 0.24mH | 90A | 230 | 190 | 180 | 8 | 160 | 95 | Figure 1 | 15 |
| | 0.18mH | 120A | 230 | 190 | 190 | 8 | 160 | 105 | Figure 1 | 18 |
| | 0.15mH | 150A | 230 | 180 | 200 | 10 | 160 | 120 | Figure 1 | 25 |
| | 0.11mH | 200A | 280 | 250 | 230 | 10 | 160 | 135 | Figure 1 | 30 |
| | 0.09mH | 250A | 280 | 250 | 230 | 10 | 160 | 135 | Figure 1 | 33 |
| | 0.06mH | 330A | 320 | 260 | 240 | 10 | 170 | 140 | Figure 1 | 42 |
| | 0.05mH | 400A | 320 | 260 | 240 | 10 | 170 | 140 | Figure 1 | 45 |

11.3 Input Noise Filters

Install a noise filter on power supply side to eliminate noise transmitted between the power line and the inverter. The inverter noise filter shown in table 11.3.1 and 11.3.2 below meets the EN61800-3 class A specification. 460V inverter class models can be ordered with integrated noise filter.

Table 11.3.1 Input Noise Filter Specifications and Ratings (IP20)

| Inverter size | | Noise filter | | | |
|------------------|-------------------------|----------------|---------------|-------------------|---------------|
| Input voltage | HP | Model | Rated current | Dimension | Part Number |
| 3 ϕ 230V | 1HP/2HP | FS32125-11-99 | 11 | 263.8*45*70 | 4KA53X079T01 |
| | 3HP/5HP | FS32124-23-99 | 23 | 290*50*85 | 4KA53X080T01 |
| | 7.5HP/10HP | FS32123-42-99 | 42 | 330*85*90 | 4KA53X081T01 |
| | 15HP | FS32125-61-99 | 61 | 318*80*135 | 4KA53X082T01 |
| | 20HP/25HP | FS32125-86-99 | 86 | 360*95*90 | 4KA53X083T01 |
| | 30HP/40HP | FS32125-150-99 | 150 | 320*226.5*86 | 4KA53X084T01 |
| | 50HP/60HP | FS32125-232-99 | 232 | 320*226.5*86 | 4KA53X095T01 |
| | 75HP/100HP | FS32125-343-99 | 343 | 320*226.5*86 | 4KA53X096T01 |
| 3 ϕ 460V | 1HP/2HP/3HP | FS32128-8-99 | 8 | 63.5*130*92 | 4KA53X085T01 |
| | 5HP/7.5HP | FS32127-19-99 | 19 | 85.5*140*91.2 | 4KA53X086T01 |
| | 10HP/15HP | FS32126-33-99 | 33 | 100.7*210*101 | 4KA53X087T01 |
| | 20HP/25HP/30HP | FS32126-63-99 | 63 | 138.3*256.2*129.3 | 4KA53X088T11 |
| | 40HP/50HP/60HP | FS32126-112-99 | 112 | 150*283*125.8 | 4KA53X089T11 |
| | 75HP/100HP | FS32126-181-99 | 181 | 320*226.5*86 | 4KA53X097T01 |
| | 125HP/150HP/175HP/215HP | FS32126-361-99 | 361 | 320*226.5*86 | 4KA53X098T01 |
| | 250HP/300HP/375HP/425HP | FS6101-800-99 | 800 | C/F | 4H000D1910004 |

B. Input or Output Noise Filter (EMI Suppression Zero Phase Core)

- Part Number: 4H000D0250001
- Select a matched ferrite core to suppress EMI noise according to the required power rating and wire size.
- The ferrite core can attenuate high frequencies in the range of 100 kHz to 50 MHz, as shown in figure 11.4.1 below, and therefore should minimize the RFI generated by the inverter.
- The zero-sequence noise ferrite core can be installed either on the input side or on the output side. The wire around the core for each phase should be wound by following the same convention and in one direction. The more turns without resulting in saturation the better the attenuation. If the wire size is too large to be wound, all the wiring can be grouped and put through several cores together in one direction.

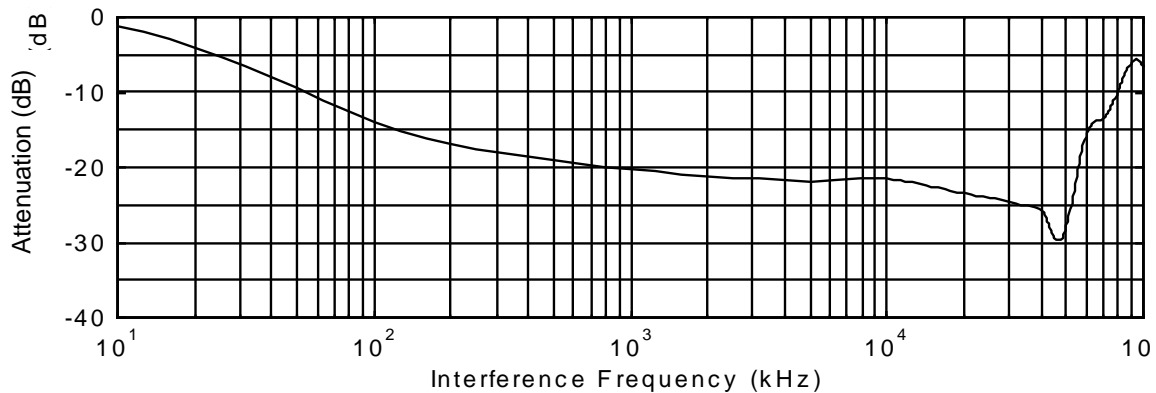

Fig. 11.4.1 Frequency attenuation characteristics (10 windings case)

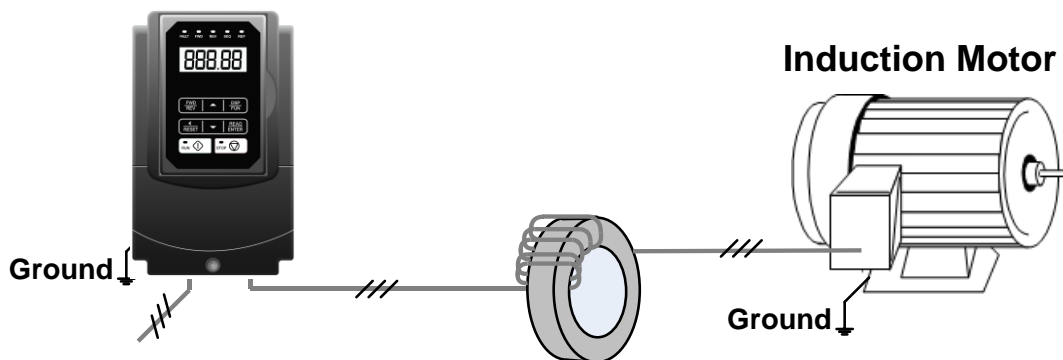

Fig. 11.4.2 Example of EMI Suppression Zero Phase Core Application

Note: All the wiring of phases U/T1, V/T2, W/T3 must pass through the same zero-phase core without crossing over.

11.4 Input Current and Fuse Specifications

230V class (IP20)

| Model | Horse power | KVA | 100% of rated output current | Rated input current | Fuse rating |
|--------------|-------------|------|------------------------------|---------------------|-------------|
| F510-2005-C3 | 5 | 5.5 | 14.5 | 16 | 30 |
| F510-2008-C3 | 7.5 | 8.0 | 21 | 22.3 | 45 |
| F510-2010-C3 | 10 | 11.4 | 30 | 31.6 | 60 |
| F510-2015-C3 | 15 | 15 | 40 | 41.7 | 80 |
| F510-2020-C3 | 20 | 21 | 56 | 60.9 | 125 |
| F510-2025-C3 | 25 | 26 | 69 | 75 | 150 |
| F510-2030-C3 | 30 | 30 | 79 | 85.9 | 175 |
| F510-2040-C3 | 40 | 42 | 110 | 119.6 | 225 |
| F510-2050-C3 | 50 | 53 | 138 | 150 | 275 |
| F510-2060-C3 | 60 | 64 | 169 | 186 | 325 |
| F510-2075-C3 | 75 | 76 | 200 | 232 | 400 |
| F510-2100-C3 | 100 | 95 | 250 | 275 | 500 |
| F510-2125-C3 | 125 | 119 | 312 | 343 | 600 |
| F510-2150-C3 | 150 | 152 | 400 | 440 | 800 |

460V class (IP20)

| Model | Horse power | KVA | 100% of rated output current | Rated input current | Fuse rating |
|--------------|-------------|------|------------------------------|---------------------|-------------|
| F510-4005-C3 | 5 | 7.0 | 9.2 | 9.6 | 20 |
| F510-4008-C3 | 7.5 | 8.5 | 11.1 | 11.6 | 20 |
| F510-4010-C3 | 10 | 13.3 | 17.5 | 18.2 | 30 |
| F510-4015-C3 | 15 | 18 | 23 | 24 | 40 |
| F510-4020-C3 | 20 | 24 | 31 | 32.3 | 50 |
| F510-4025-C3 | 25 | 29 | 38 | 41.3 | 70 |
| F510-4030-C3 | 30 | 34 | 44 | 47.8 | 80 |
| F510-4040-C3 | 40 | 41 | 54 | 58.7 | 100 |
| F510-4050-C3 | 50 | 55 | 72 | 75 | 125 |
| F510-4060-C3 | 60 | 67 | 88 | 95.7 | 150 |
| F510-4075-C3 | 75 | 79 | 103 | 112 | 200 |
| F510-4100-C3 | 100 | 111 | 145 | 141 | 250 |
| F510-4125-C3 | 125 | 126 | 165 | 181 | 300 |
| F510-4150-C3 | 150 | 159 | 208 | 229 | 350 |
| F510-4175-C3 | 175 | 191 | 250 | 275 | 500 |
| F510-4215-C3 | 215 | 226 | 296 | 325 | 600 |
| F510-4250-C3 | 250 | 250 | 328 | 360 | 700 |

11.5 Other Options

A. Blank cover and keypad extension cable

When used for remote control purposes, the keypad can be removed and remotely connected with an extension cable. Extension cables are available in the following lengths: 1m (3.3ft), 2m (6.6ft), 3m (10ft), and 5m (16.4ft).

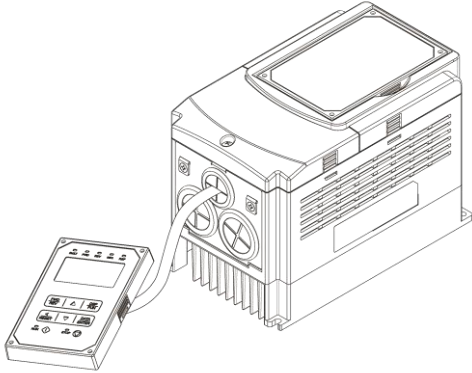

| Name | Model | specification |
|---------------------------|------------|--------------------|
| LED digital operator wire | JN5-CB-01M | 1m (3.3ft) |
| | JN5-CB-02M | 2m (6.6ft) |
| | JN5-CB-03M | 3m (10ft) |
| | JN5-CB-05M | 5m (16.4ft) |

When using a remote mount keypad a blank cover can be installed in place of the original keypad to prevent dust and debris from entering the inverter.



Blank keypad cover

| Name | Model | specification |
|-------------|------------|---------------|
| Blank cover | JN5-OP-A03 | Blank cover |

B. 1 to 8 Pump Card

Refer to instruction manual of the option card on how to install.

JN5-IO-8DO Card: 8 Relay Output Card.

Terminals of JN5-IO-8DO:

| Terminal | Description |
|----------|-----------------------------|
| RY1~RY8 | Relay1~Relay8 Form A output |
| CM1~CM4 | Common terminal output |

Wiring of JN5-IO-8DO (Example):

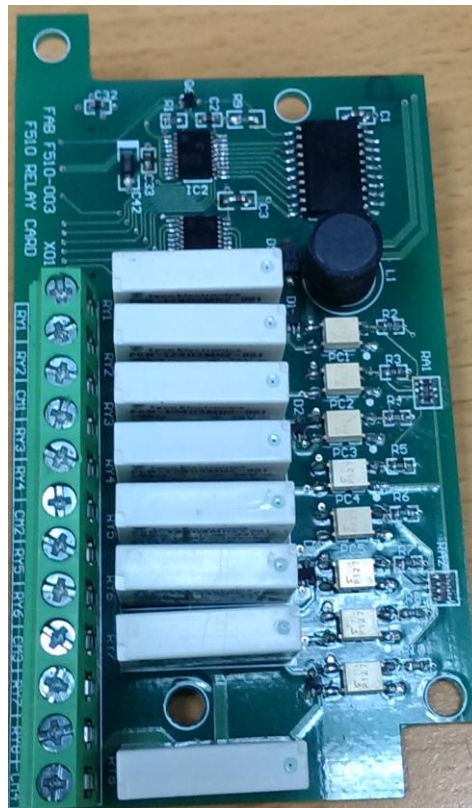
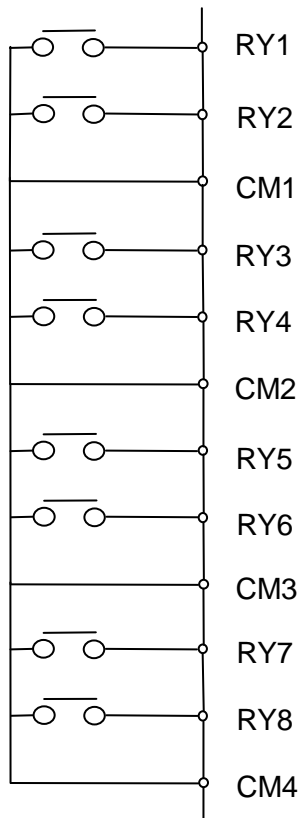

C. Copy Unit (JN5-CU)

The copy unit is used to copy an inverter parameter setup to another inverter. The copy unit saves time in applications with multiple inverters requiring the same parameter setup.

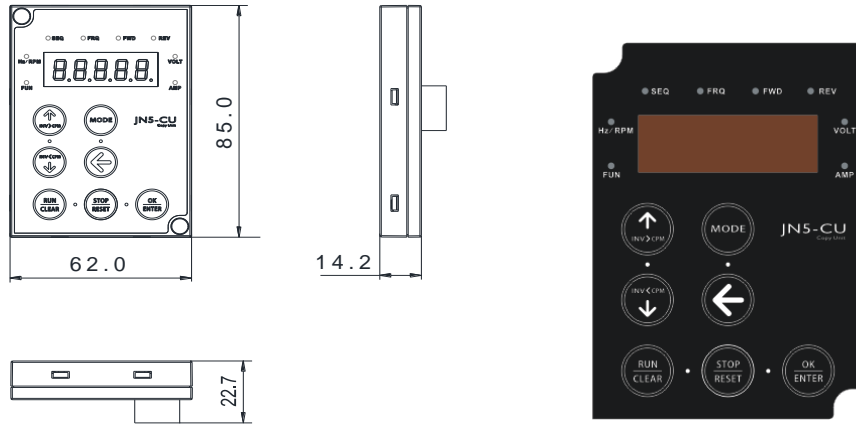

Copy Unit (JN5-CU) dimensions

D. Copy Module (JN5-CU-M)

The copy module is used to copy up to 128 parameters from one inverter to another inverter.

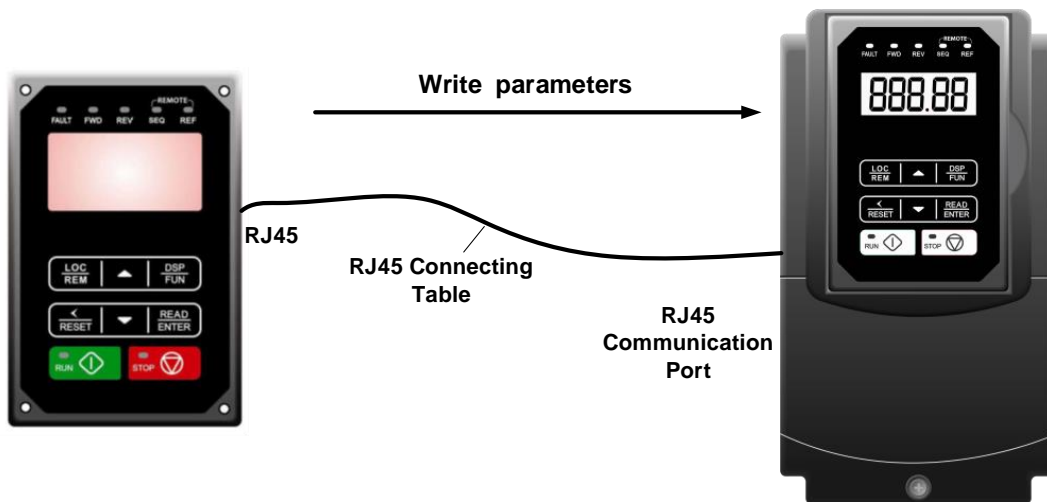

E. RJ45 to USB Communication Cable (6ft / 1.8m) (JN5-CM-USB)

The communication cable is used to communicate with the TECO Link software directly to the inverter using the PC USB port.

- Cable:

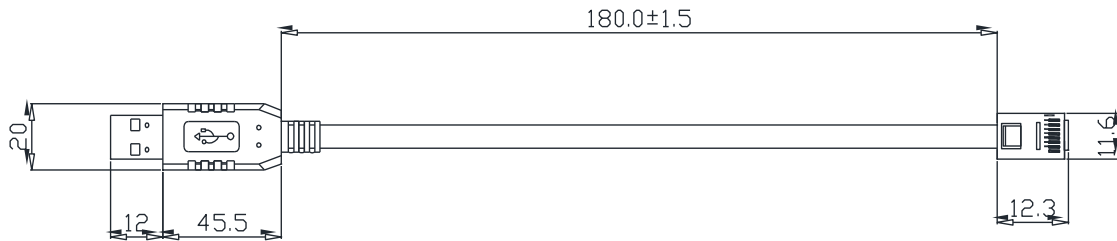

- Connect to the RS45 port:

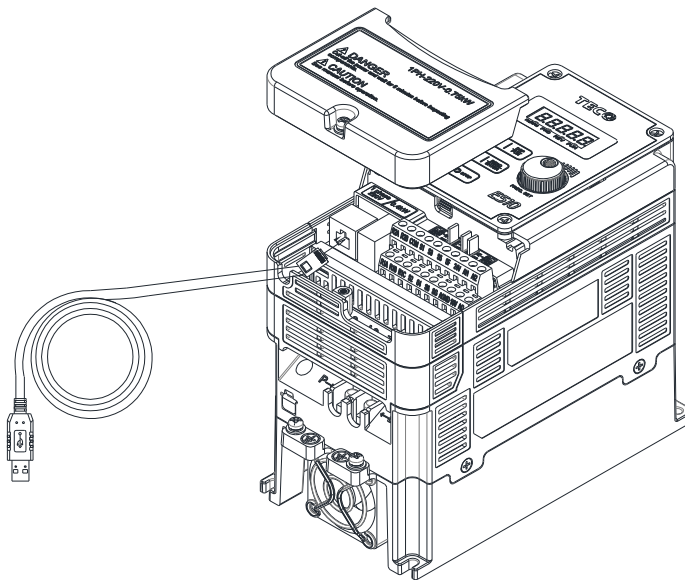

11.6 Communication options

(a) PROFIBUS communication interface module (JN5-CM-PDP)

For wiring example and communication setup refer to JN5-CM-PDP communication option manual.

(b) DEVICENET communication interface module (JN5-CM-DNET)

For wiring example and communication setup refer to JN5-CM-DNET communication option manual.

(c) CANopen communication interface module (JN5-CM-CAN)

For wiring example and communication setup refer to JN5-CM-VAN communication option manual.

(d) TCP-IP communication interface module (JN5-CM-TCPIP)

For wiring example and communication setup refer to JN5-CM-TCPIP communication option manual.

Appendix A: Single and Multi-Pump Wiring

■ PUMP Wiring Diagram for Pressure Sensor of Voltage Type

Single Pump:

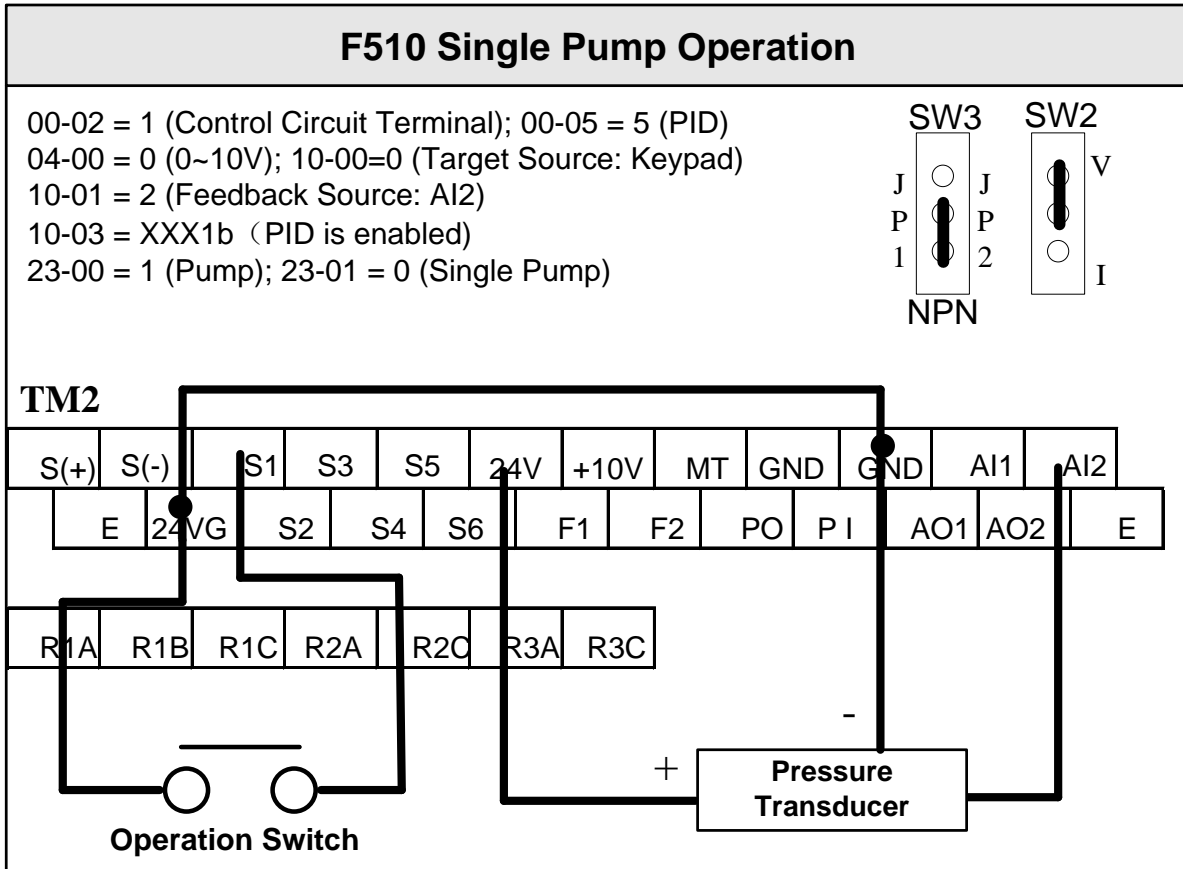

Multi-Pump:

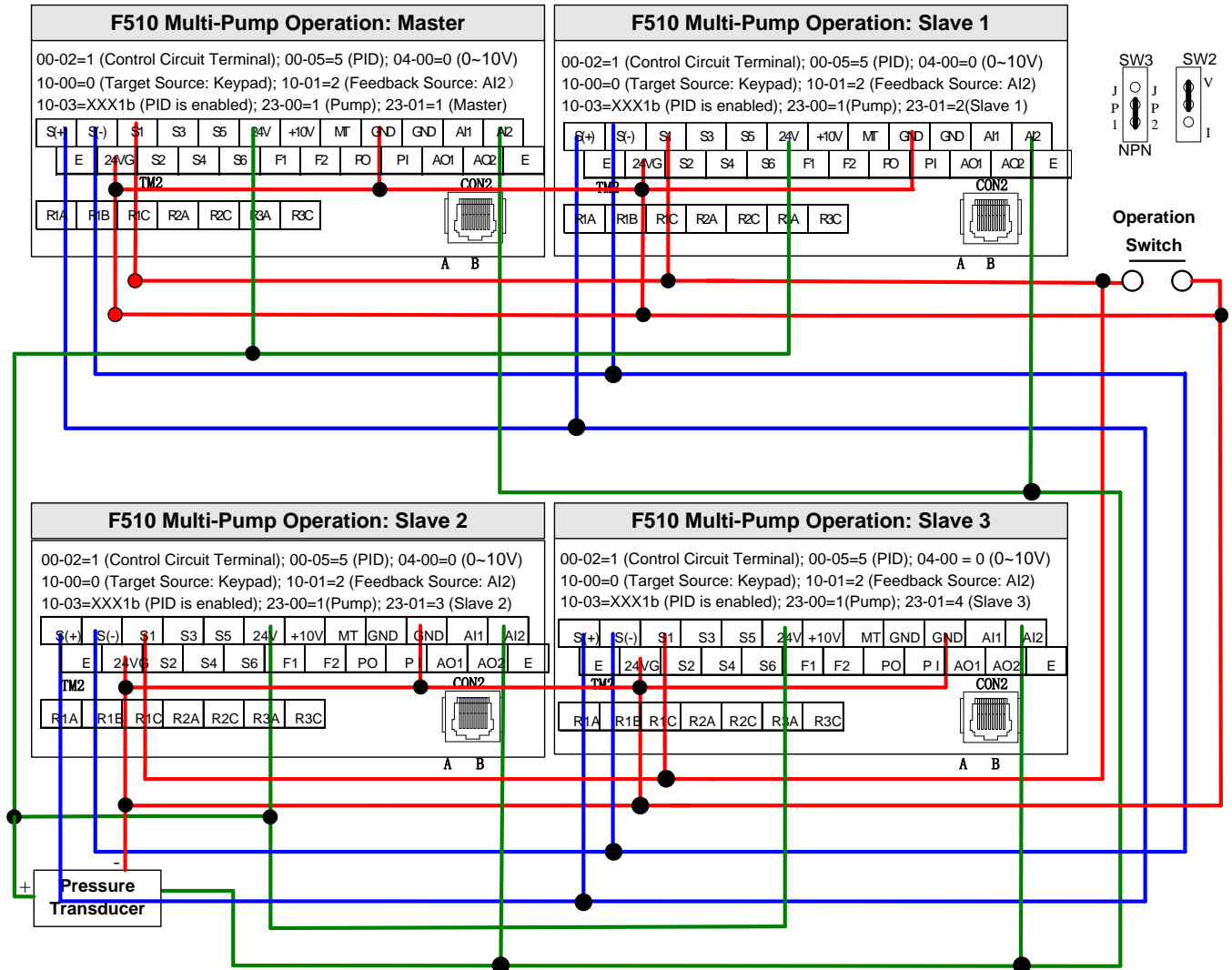

■ PUMP Wiring Diagram for Pressure Sensor of Current Type

Single Pump:

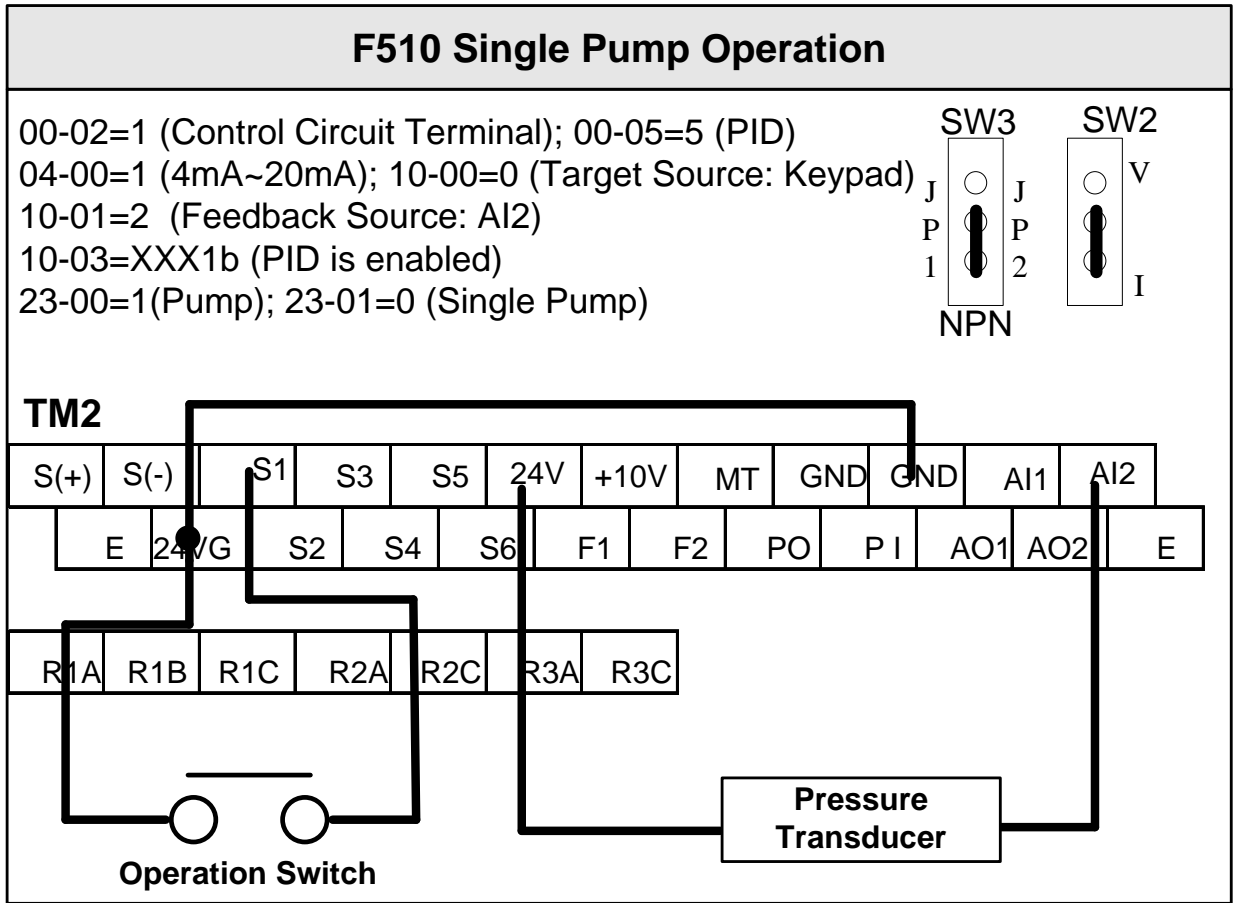

Multi-Pump:

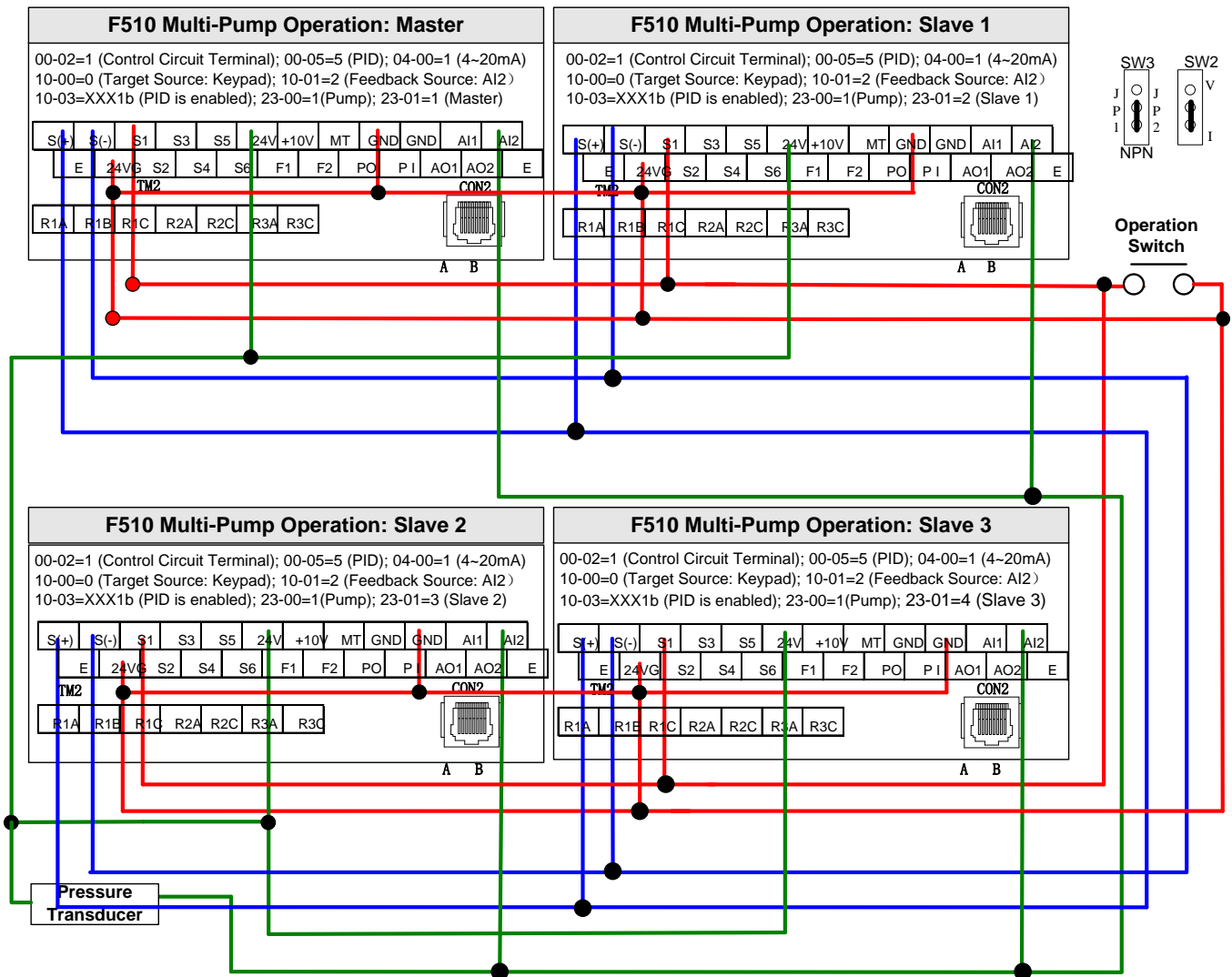

Notes:

1. Check position of dip switch SW2 and SW3.
2. It is required to reconnect after setting Master/ Follower.
3. 24VG and GND have to be connected together.
4. When the communication mode is selected for multiple pumps in parallel connection (09-01=3), baud rate settings (09-02) of both Master and Follower have to be the same. Refer to parameter 23-31.
5. When wiring pressure sensor to multi-pump units make sure to set Follower parameter 04-07(AI2 Gain) =252.0% and 04-08(AI1 Bias) =25.0%.

Appendix B: UL Instructions

Danger

Electric Shock Hazard

Do not connect or disconnect wiring while the power is on.
Failure to comply will result in death or serious injury.

Warning

Electric Shock Hazard

Do not operate equipment with covers removed.

Failure to comply could result in death or serious injury.

The diagrams in this section may show inverters without covers or safety shields to show details. Be sure to reinstall covers or shields before operating the inverters and run the inverters according to the instructions described in this manual.

Always ground the motor-side grounding terminal.

Improper equipment grounding could result in death or serious injury by contacting the motor case.

Do not touch any terminals before the capacitors have fully discharged.

Failure to comply could result in death or serious injury.

Before wiring terminals, disconnect all power to the equipment. The internal capacitor remains charged even after the power supply is turned off. After shutting off the power, wait for at least the amount of time specified on the inverter before touching any components.

Do not allow unqualified personnel to perform work on the inverter.

Failure to comply could result in death or serious injury.

Installation, maintenance, inspection, and servicing must be performed only by authorized personnel familiar with installation, adjustment, and maintenance of inverters.

Do not perform work on the inverter while wearing loose clothing, jewelry, or lack of eye protection.

Failure to comply could result in death or serious injury.

Remove all metal objects such as watches and rings, secure loose clothing, and wear eye protection before beginning work on the inverter.

Do not remove covers or touch circuit boards while the power is on.

Failure to comply could result in death or serious injury.

Warning

Fire Hazard

Tighten all terminal screws to the specified tightening torque.

Loose electrical connections could result in death or serious injury by fire due to overheating of electrical connections.

Do not use an improper voltage source.

Failure to comply could result in death or serious injury by fire.

Verify that the rated voltage of the inverter matches the voltage of the incoming power supply before applying power.

Do not use improper combustible materials.

Failure to comply could result in death or serious injury by fire. Attach the inverter to metal or other noncombustible material.

NOTICE

Observe proper electrostatic discharge procedures (ESD) when handling the inverter and circuit boards.

Failure to comply may result in ESD damage to the inverter circuitry.

Never connect or disconnect the motor from the inverter while the inverter is outputting voltage.

Improper equipment sequencing could result in damage to the inverter.

Do not use unshielded cable for control wiring.

Failure to comply may cause electrical interference resulting in poor system performance. Use shielded twisted-pair wires and ground the shield to the ground terminal of the inverter.

Do not modify the inverter circuitry.

Failure to comply could result in damage to the inverter and will void warranty. TECO is not responsible for any modification of the product made by the user. This product must not be modified.

Check all the wiring to ensure that all connections are correct after installing the inverter and connecting any other devices.

Failure to comply could result in damage to the inverter.

❖ **UL Standards**

The UL/cUL mark applies to products in the United States and Canada and it means that UL has performed product testing and evaluation and determined that their stringent standards for product safety have been met. For a product to receive UL certification, all components inside that product must also receive UL certification.



❖ **UL Standards Compliance**

This inverter is tested in accordance with UL standard UL508C and complies with UL requirements. To ensure continued compliance when using this inverter in combination with other equipment, meet the following conditions:

■ **Installation Area**

Do not install the inverter to an area greater than pollution severity 2 (UL standard).

■ Main Circuit Terminal Wiring

UL approval requires crimp terminals when wiring the inverter's main circuit terminals. Use crimping tools as specified by the crimp terminal manufacturer. TECO recommends crimp terminals made by NICHIFU for the insulation cap.

The table below matches inverter models with crimp terminals and insulation caps. Orders can be placed with a TECO representative or directly with the TECO sales department.

Closed-Loop Crimp Terminal Size

| Drive Model F510 | Wire Gauge mm ² , (AWG) | | Terminal | Crimp Terminal | Tool | Insulation Cap |
|---------------------|---------------------------------------|---------------------|----------|-------------------|--------------------------|----------------|
| | R/L1, S/L2, T/L3 | U/T1, V/T2, W/T3 | Screws | Model No. | Machine No. | Model No. |
| 2008 | 5.5 (10) | | M4 | R5.5-4 | Nichifu NH 1 / 9 | TIC 5.5 |
| 2015 | 14 (6) | | M4 | R14-6 | Nichifu NOP 60 | TIC 8 |
| 2030 | 38 (2) | | M6 | R38-6 | Nichifu NOP 60 / 150H | TIC 22 |
| 2050 | 80 (3/0) | | M8 | R80-8 | Nichifu NOP 60 / 150H | TIC 60 |
| 2075 | 150 (4/0) | | M8 | R150-8 | Nichifu NOP 150H | TIC 80 |
| 2125 | 300 (4/0)*2 | | M10 | R150-10 | Nichifu NOP 150H | TIC 100 |
| 4010 | 5.5 (10) | | M4 | R5.5-4 | Nichifu NH | 9-Jan |
| 4020 | 8 (8) | | M6 | R8-6 | Nichifu NOP 60 | TIC 8 |
| 4040 | 22 (6) | | M6 | R22-6 | Nichifu NOP 60 / 150H | TIC 14 |
| 4075 | 60 (2) | | M8 | R60-8 | Nichifu NOP 60 / 150H | TIC 38 |
| 4125 | 150 (3/0) | | M8 | R150-8 | Nichifu NOP 150H | TIC 80 |
| 4250 | 300 (4/0)*2 | | M10 | R150-10 | Nichifu NOP 150H | TIC 100 |

❖ Type 1

During installation, all conduit hole plugs shall be removed, and all conduit holes shall be used.

Note: Contact TECO for inverter ratings 2125 - 2150 and 4250 - 4425.

230V Class

| Drive Model F510 | Fuse Type | |
|---------------------------------------|---|------------------------|
| | Manufacturer: Bussmann / FERRAZ SHAWMUT | |
| | Model | Fuse Ampere Rating (A) |
| 200 V Class Three-Phase Drives | | |
| 2005 | Bussmann 50FE | 690V 50A |
| 2008 | Bussmann 50FE | 690V 50A |
| 2010 | Bussmann 63FE | 690V 63A |
| 2015 | FERRAZ SHAWMUT A50QS100-4 | 500V 100A |
| 2020 | Bussmann 120FEE / FERRAZ A50QS150-4 | 690V 120A / 500V 150A |
| 2025 | FERRAZ SHAWMUT A50QS150-4 | 500V 150A |
| 2030 | FERRAZ SHAWMUT A50QS200-4 | 500V 200A |
| 2040 | FERRAZ SHAWMUT A50QS250-4 | 500V 250A |
| 2050 | FERRAZ SHAWMUT A50QS300-4 | 500V 300A |
| 2060 | FERRAZ SHAWMUT A50QS400-4 | 500V 400A |
| 2075 | FERRAZ SHAWMUT A50QS500-4 | 500V 500A |
| 2100 | FERRAZ SHAWMUT A50QS600-4 | 500V 600A |
| 2125 | FERRAZ SHAWMUT A50QS700-4 | 500V 700A |

460V Class

| Drive Model F510 | Fuse Type | |
|---------------------------------------|---|------------------------|
| | Manufacturer: Bussmann / FERRAZ SHAWMUT | |
| | Model | Fuse Ampere Rating (A) |
| 400 V Class Three-Phase Drives | | |
| 4005 | Bussmann 16CT | 690V 16A |
| 4008 | Bussmann 25ET | 690V 25A |
| 4010 | Bussmann 40FE | 690V 40A |
| 4015 | Bussmann 50FE | 690V 50A |
| 4020 | Bussmann 63FE | 690V 63A |
| 4025 | Bussmann 80FE | 500V 80A |
| 4030 | Bussmann 100FE / FERRAZ A50QS100-4 | 690V 100A / 500V 100A |
| 4040 | Bussmann 120FEE | 500V 120A |
| 4050 | FERRAZ SHAWMUT A50QS150-4 | 500V 15A |
| 4060 | FERRAZ SHAWMUT A50QS200-4 | 500V 200A |
| 4075 | FERRAZ SHAWMUT A50QS250-4 | 500V 250A |
| 4100 | FERRAZ SHAWMUT A50QS300-4 | 500V 300A |
| 4125 | FERRAZ SHAWMUT A50QS400-4 | 500V 400A |
| 4150 | FERRAZ SHAWMUT A50QS500-4 | 500V 500A |
| 4175 | FERRAZ SHAWMUT A50QS600-4 | 500V 600A |
| 4215 | FERRAZ SHAWMUT A50QS700-4 | 500V 700A |
| 4250 | FERRAZ SHAWMUT A50QS700-4 | 500V 700A |

❖ **Motor Over Temperature Protection**

Motor over temperature protection shall be provided in the end use application.

■ **Field Wiring Terminals**

All input and output field wiring terminals not located within the motor circuit shall be marked to indicate the proper connections that are to be made to each terminal and indicate that copper conductors, rated 75°C are to be used.

■ **Inverter Short-Circuit Rating**

This inverter has undergone the UL short-circuit test, which certifies that during a short circuit in the power supply the current flow will not rise above value. Please see electrical ratings for maximum voltage and table below for current.

- The MCCB and breaker protection and fuse ratings (refer to the preceding table) shall be equal to or greater than the short-circuit tolerance of the power supply being used.
- Suitable for use on a circuit capable of delivering not more than (A) RMS symmetrical amperes for DiJ2.IHp in 240 / 480 V class drives motor overload protection.

| Horse Power (Hp) | Current (A) | Voltage (V) |
|---------------------------|----------------------|----------------------|
| 1 - 50 | 5,000 | 240 / 480 |
| 51 - 200 | 10,000 | 240 / 480 |
| 201 - 400 | 18,000 | 240 / 480 |
| 401 - 600 | 30,000 | 240 / 480 |

❖ Inverter Motor Overload Protection

Set parameter 02-01 (motor rated current) to the appropriate value to enable motor overload protection. The internal motor overload protection is UL listed and in accordance with the NEC and CEC.

■ 02-01 Motor Rated Current

Setting Range Model Dependent

Factory Default: Model Dependent

The motor rated current parameter (02-01) protects the motor and allows for proper vector control when using open loop vector or flux vector control methods (00-00 = 2 or 3). The motor protection parameter 08-05 is set as factory default. Set 02-01 to the full load amps (FLA) stamped on the nameplate of the motor. The operator must enter the rated current of the motor (17-02) in the menu during auto-tuning. If the auto-tuning operation completes successfully (17-00 = 0), the value entered into 17-02 will automatically write into 02-01.

■ 08-05 Motor Overload Protection Selection

The inverter has an electronic overload protection function (OL1) based on time, output current, and output frequency, which protects the motor from overheating. The electronic thermal overload function is UL-recognized, so it does not require an external thermal overload relay for single motor operation. This parameter selects the motor overload curve used according to the type of motor applied.

| 08-05 | Selection for motor overload protection (OL1) |
|-------|---|
| Range | xxx0b : Motor overload is disabled xxx1b : Motor overload is enabled xx0xb : Cold start of motor overload xx1xb : Hot start of motor overload x0xxb : Standard motor x1xxb : Special motor |

Sets the motor overload protection function in 08-05 according to the applicable motor.

08-05 = ---OB: Disables the motor overload protection function when two or more motors are connected to a single inverter. Use an alternative method to provide separate overload protection for each motor such as connecting a thermal overload relay to the power line of each motor.

08-05 = --1-B: The motor overload protection function should be set to hot start protection characteristic curve when the power supply is turned on and off frequently, because the thermal values are reset each time when the power is turned off.

08-05 = -0—B: For motors without a forced cooling fan (general purpose standard motor), the heat dissipation capability is lower when in low speed operation.

08-05 = -1—B: For motors with a forced cooling fan (inverter duty or VIF motor), the heat dissipation capability is not dependent upon the rotating speed.

To protect the motor from overload by using electronic overload protection, be sure to set parameter 02-01 according to the rated current value shown on the motor nameplate.

Refer to the following "Motor Overload Protection Time" for the standard motor overload protection curve example: Setting 08-05 = -0--B.

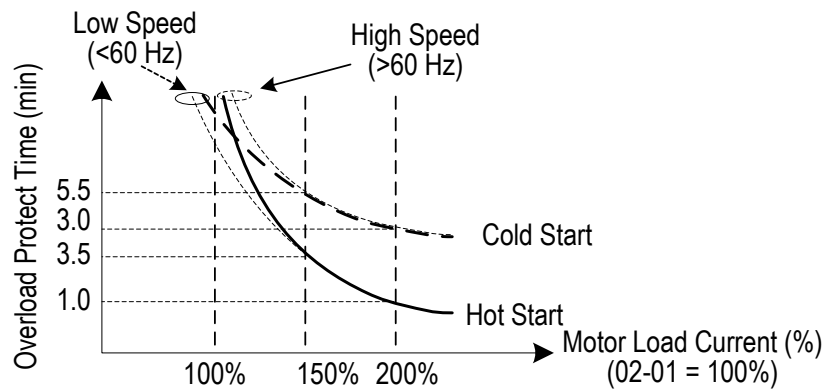

■ 08-06 Motor Overload Operation Selection

| | |
|--------------|--|
| 08-06 | Start-up mode of overload protection operation (OL1) |
| Range | 0: Stop output after overload protection 1: Continuous operation after overload protection. |

08-06=0: When the inverter detects a motor overload the inverter output is turned off and the OL1 fault message will flash on the keypad. Press RESET button on the keypad or activate the reset function through the multi-function inputs to reset the OL1 fault.

08-06=1: When the inverter detects a motor overload the inverter will continue running and the OL1 alarm message will flash on the keypad until the motor current falls within the normal operating range.

UL- Additional Data

Closed-Loop Crimp Terminal Size

| Drive Model | Wire Gauge mm2 (AWG) | | Terminal | Crimp Terminal | Tool | Insulation Cap |
|-------------|-------------------------|---------------------|----------|-------------------|------------------|-------------------|
| | R/L1, S/L2, T/L3 | U/T1, V/T2, W/T3 | Screws | Model No. | Machine No. | Model No. |
| F510 | | | | | | |
| 2175 | 152 (300)*2 | | M12 | R150-12*2 | Nichifu NOP 150H | TIC 150 |
| 4300 | 203 (400)*2 | | M12 | R200-12S*2 | Nichifu NOH 300K | TIC 200 |
| 4375 | 253 (500)*2 | | M12 | R325-12S*2 | Nichifu NOH 300K | TIC 325 |
| 4425 | 253 (500)*2 | | M12 | R325-12S*2 | Nichifu NOH 300K | TIC 325 |

❖ **Type 1**

During installation, all conduit hole plugs shall be removed, and all conduit holes shall be used

Recommended Input Fuse Selection

| Drive Model F510 | Fuse Type | |
|---------------------------------------|---|------------------------|
| | Manufacturer: Bussmann / FERRAZ SHAWMUT | |
| | Model | Fuse Ampere Rating (A) |
| 200 V Class Three-Phase Drives | | |
| 2150 | Bussmann 170M5464 | 690V 800A |
| 2175 | Bussmann 170M5464 | 690V 800A |

| Drive Model F510 | Fuse Type | |
|---------------------------------------|---|------------------------|
| | Manufacturer: Bussmann / FERRAZ SHAWMUT | |
| | Model | Fuse Ampere Rating (A) |
| 400 V Class Three-Phase Drives | | |
| 4300 | Bussmann 170M5464 | 690V 800A |
| 4375 | Bussmann 170M5464 | 690V 800A |
| 4425 | Bussmann 170M5466 | 690V 1000A |
| 4425 | Bussmann 170M5466 | 690V 1000A |

TECO



INVERTER

F510

Teco-Westinghouse Motor Company

5100 N. IH-35

Round Rock, Texas 78681

1-800-279-4007

www.tecowestinghouse.com

TECO Electric & Machinery Co., Ltd.

10F., No.3-1, Yuancyu St., Nangang District,

Taipei City 115, Taiwan

Tel: +886-2-6615-9111

Fax: +886-2-6615-0933

www.teco.com.tw

Distributor

Ver 01: 2014.07