

# Foreword

Thank you for using our company's inverter. Before using it, you must read this instruction manual carefully. Please use it after you are familiar with the precautions of this product.

## **Installation Environment:**

1. Installed indoors and in a well-ventilated place, generally should be installed vertically to ensure the best cooling effect.
2. The ambient temperature is required to be in the range of -10~45°C.
3. The ambient humidity is required to be less than 90%, without water droplets condensing.
4. Install in a place with vibration less than 0.5G to prevent falling damage. The inverter is not allowed to suffer sudden impact.
5. Install in an environment away from magnetic fields and free of flammable and explosive substances.
6. Make sure to install the inverter on fireproof materials (such as metal) to prevent fire.
7. Make sure that no foreign objects enter the inverter to prevent circuit shortcuts from burning down the inverter.

# Safety Precautions

1. Before wiring, please confirm whether the input power is in the power off state.
2. It is strictly forbidden to operate with wet hands during wiring operation, and professional electrical engineering personnel are required.
3. The main circuit terminal and the cable must be firmly connected, otherwise the inverter may be damaged due to poor contact.
4. For safety reasons, the ground terminal of the inverter must be reliably grounded.
5. It is strictly forbidden to connect the AC 220V or 380V power supply to the terminals other than TA and TC in the control terminal.
6. It is strictly forbidden to connect the AC power supply to the output U, V, W terminals of the inverter.
7. On the input power supply side of the inverter, be sure to configure a fuseless circuit breaker for circuit protection or a circuit breaker with leakage protection to prevent the accident caused by the inverter from expanding.
8. Please confirm whether the voltage of the AC main circuit power supply is consistent with the rated voltage of the inverter.
9. Do not intervene the contactor in the output circuit. If necessary, please consult our company or relevant qualified personnel in advance.
10. When the inverter is powered on, do not open the cover or perform wiring work.
11. Do not touch the inside of the inverter after power-on, and do not put conductive rods or other

objects into the inverter.

12. For inverters that have been stored for more than half a year, a charging experiment should be conducted before use to restore the characteristics of the filter capacitor of the inverter main circuit. When charging, the voltage regulator should be used to gradually increase the voltage to the rated value. Within 1~2 hours, otherwise there is a risk of electric shock or explosion.
13. Since the output voltage of the inverter is a PWM pulse wave, please do not install capacitors or inrush current absorbers at its output. If it has been installed, be sure to remove it.
14. It is strictly forbidden to use contactors and other switching devices on the input side of the inverter to directly start and stop frequently.
15. Derating is required for areas with an altitude of more than 1000 meters. -Generally, the derating is about 10% every 1000 meters.°
16. If there are abnormal phenomena such as smoke, odor, strange noise, etc. in the inverter, please immediately cut off the power and carry out maintenance or call the agent for service.
17. When carrying out inspection and maintenance, the main circuit power should be cut off first.
18. The company will not be responsible for any loss of property and personnel caused by unauthorized modification of the inverter or failure to follow the procedures in this manual.

# 1 General technical specifications and product models

## General technical specifications

Item		Description
Input	Rated voltage frequency	380V or 220V: 50HZ/60HZ
	Allowable voltage working range	Fluctuation range: $\leq \pm 20\%$ ; voltage unbalance rate: $< 3\%$ ; frequency: $\pm 5\%$
Output	Rated voltage	0~380V or 0 ~220V
	Frequency	0~999.9HZ
	Overload capacity	100% rated current for 1 minute
Main control performance	Control model	V/F control, advanced VF control, separate VF control, VF square curve control, without PG current vector control
	Modulation	Space voltage vector PWM modulation
	Speed range	1: 100 (without PG vector control)
	Starting torque	150% rated torque at 3.0 Hz (Advanced VF control)
	Speed stabilization accuracy	$\leq \pm 0.2\%$ rated synchronous speed
	Speed fluctuation	$\leq \pm 0.5\%$ rated synchronous speed
	Torque response	$\leq 50\text{ms}$ without PG vector control
	Torque control	Support torque control without PG vector control mode Torque control accuracy: $\pm 5\%$
	Frequency accuracy	Digital setting: maximum frequency $\times \pm 0.01\%$ ; Analog setting: maximum frequency $\times \pm 0.2\%$
	Frequency resolution	Digital setting: 0.01Hz; Analog setting: maximum frequency $\times 0.05\%$
	Torque boost	Automatic torque boost, manual torque boost 0.1%~30.0%
	V/F curve	6 control modes: 1 user setting V/F curve mode, 4 torque reduction characteristic curve modes (2.0 power, 1.7 power, 1.5 power, 1.3 power) and linear curve, square curve, multi-point VF curve
	Acceleration and deceleration curve	Linear acceleration and deceleration. Time unit (minutes/second) optional, up to 999.9 seconds
DC braking	Starting frequency of DC braking at stop: 0.00-50.00HZ Braking time: 0.0-30.0S; braking current: 0.0%-50.0% rated current	
Automatic Voltage Adjustment (AVR)	When the grid voltage changes, it can automatically keep the output voltage constant	

	Automatic current limit	Automatically limit the current during operation to prevent frequent overcurrent fault tripping
	Voltage stall	Control the voltage during deceleration to prevent overvoltage protection from stopping
	Automatic carrier adjustment	Automatically adjust carrier frequency according to load characteristics and temperature characteristics; multiple carrier modes are optional
Customization function	Separate VF control	Easy to implement various power supply designs
	Textile swing frequency	Textile swing frequency control, can realize fixed swing frequency and variable swing frequency .
	Frequency combination function	The running command channel and frequency reference channel can be combined arbitrarily
	Jog	The jog forward rotation frequency can be set and the jog priority is enabled. The jog frequency range: 0.00Hz~50.00Hz; the jog acceleration and deceleration time can be set from 0.1 to 999.9s, and the jog interval time can be set from 0.1 to 999.9s .
	Multi-speed operation	Achieve multi-speed operation through built-in PLC or control terminal
	Built-in process closed-loop control	Can easily form a closed-loop control system.
	Water supply burst detection	Burst detection delay time, high pressure detection threshold, low pressure detection threshold
Operation function	Run command channel	Operation panel. Bolt terminal, serial communication port, can be switched in various ways
	Frequency given channel	2 kinds of digital setting, analog voltage setting, analog current setting, pulse setting, terminal setting, multi-speed setting, etc.
	Auxiliary frequency setting	Realize flexible and precise frequency fine-tuning and frequency synthesis
	Pulse output terminal	0~50kHz pulse square wave signal output, can realize the output of physical quantities such as set frequency and output frequency
	Analog output terminal	2 analog signal outputs. The output range is flexibly set between 0~20mA or 0~10V, which can realize the output of physical quantities such as set frequency and output frequency
operating panel	LED display	Can display 26 parameters such as set frequency, output frequency, output voltage, output current, etc.
	Key function selection	Define the action range of some keys to prevent misoperation

	Protective function	Phase loss protection (optional), over-current protection, over-voltage protection, under-voltage protection, over-temperature protection. Overload protection, load loss protection, etc.
Environment	Location	Indoor. Free from direct sunlight, dust, corrosive gas, flammable gas, oil mist, water vapor, dripping or salt etc.
	Altitude	Use derating above 1000 meters, derate 10% for every 1000 meters raised
	Ambient temperature	-10C~+40C (If ambient temperature is 40C-50C, please use derating)
	Humidity	5%~95%RH, no condensation
	Vibration	Less than 5.9m/s( 0.6g)
	Storage temperature	-40C~+70C
Structure	Protection level	IP20
	Cooling method	Air-cooled, with fan control
	Efficiency	7.5KW and below >93%

#### Product Design Executive Standard

- EN 61800-3: 2017 Adjustable speed electric drive system. Part 3: Electromagnetic compatibility (EMC) requirements and specific test methods
- EN61800-2: 2015 speed adjustable electric drive system. Part 2: General requirements. Rating specifications for low voltage adjustable frequency AC drive systems
- EN 61800-5-1:2007/A1:2017 Adjustable speed electric drive system-Part 5-1: Safety requirements-electricity, heat and energy

#### Model table

Input voltage	Model	Capacity (KVA)	Input Current (A)	Adapted motor (KW)
220V 1-phase	SY2000-0R7G-S2	1.40	4.0	0.75
	SY2000-1R5G-S2	2.60	7.0	1.50
	SY2000-2R2G-S2	3.80	10.0	2.20
	SY2000-004G-S2	8.80	16.0	4.0
	SY2000-5R5G-S2	11.0	22.0	5.5
380V 3-phase	SY2000-0R7G-4	1.50	2.30	0.75
	SY2000-1R5G-4	3.70	3.70	1.5
	SY2000-2R2G-4	4.70	5.0	2.2
	SY2000-004G-4	5.90	10.5	4.0
	SY2000-5R5G-4	8.90	14.6	5.5
	SY2000-7R5G-4	11.0	20.0	7.5

# 2 Installation and wiring

## 1. Basic wiring diagram

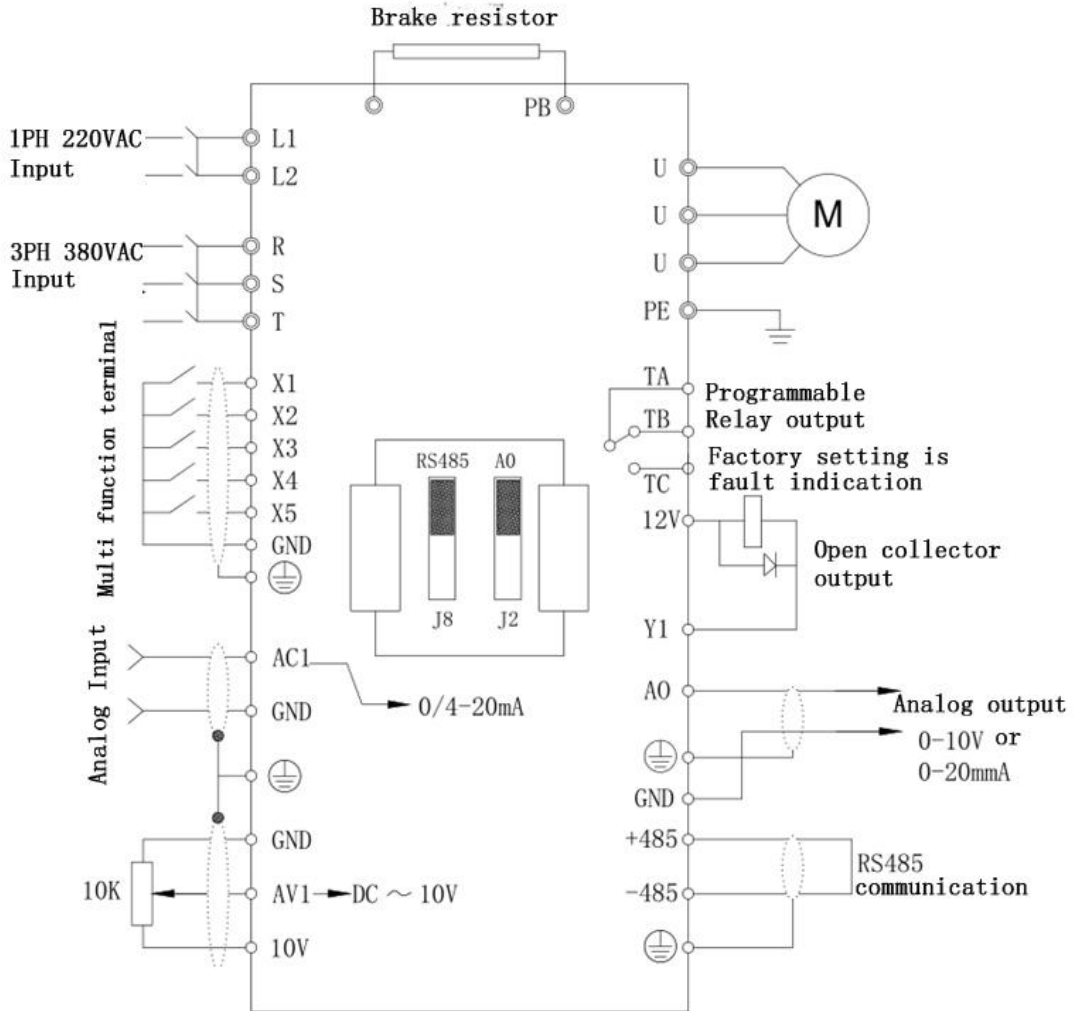

## 2. Jumper Correspondence:

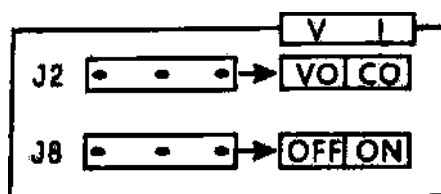

J2		
V	VO position	AO output voltage signal
I	CO position	AO output current signal
J8		
OFF position		Indicates that the matched resistance on 485 communication is not connected
ON position		Indicates that the matched resistance on 485 communication is connected

## 3. Control circuit terminal description:

Terminal function description of control circuit			
Item	Terminal label	Function Description	Specification
Multi-function digital input terminal	X1	X (X1, X2, X3, X4, X5) ~ GND is valid when they are short connected, its function is set by parameters P2.13 ~ P2.17. (Common: GND)	INPUT, 0 ~ 10V level signal, low level valid, 5mA.
	X2		
	X3		
	X4		
	X5		
Digital signal output terminal	Y1	Multi-function programmable open collector output, It can be programmed as a switching output terminal with multiple functions. (Common: GND)	OUTPUT, the maximum load current cannot bigger than 50mA.
Analog input and output terminals	ACI	ACI only receives current input, AVI only receives voltage input. The setting of the measuring range refers to the description of function codes P2.00 ~ P2.09. (Reference ground: GND)	INPUT, input voltage range: 0 ~ 10V (input impedance: 100K $\Omega$ ), input current range: 0 ~ 20mA (input impedance: 500 $\Omega$ ).
	AVI		
	AO	AO provides analog voltage / current output, which can represent 6 kinds of physical values. The output voltage and current are selected by the jumper J2 (AO jumper terminal). The default is voltage output. If want current output, only need to shorted connect the middle and the other end. For details please refer to function code F2.10. (Reference ground: GND)	OUTPUT, 0 ~ 10V DC voltage. The output voltage of the AO terminal is the PWM waveform from the CPU. The output voltage is proportional to the width of the PWM waveform.
Relay output	TA	The output of programmable relay	TA-TB: normally closed;

terminal	TB	terminals TA and TC can reach 14 kinds. For details, please refer to the introduction of F2.20 output terminal function.	TA-TC: normally open. Contact capacity: 250VAC / 2A (COSΦ = 1); 250VAC / 1A (COSΦ = 0.4), 30VDC / 1A.
	TC		
Power supply port	10V	10V is the common power supply of the analog input terminal circuit	The maximum output current is 20mA.
	12V	12V is the common power supply for digital signal input terminals	The maximum output current is 100mA.
	GND	Analog signal and 10V, digital signal and 12V power supply GND.	Analog signals and digital signals common grounded.
Communication port	485+	RS485 signal + port	Standard RS485 communication interface, not isolated from GND, please use twisted pair or shielded wire.
	485-	RS485 signal-port	

#### 4. Model specification

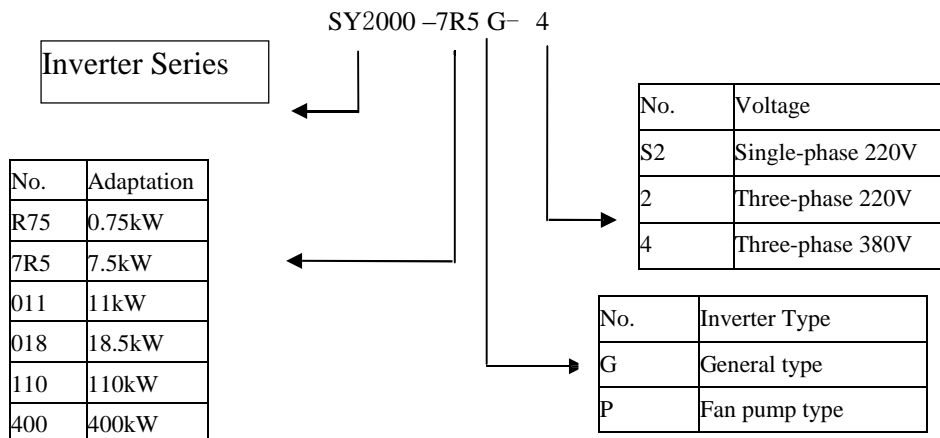

GP unification Model description	<p>Users check factory models through P0.00. P type is one lower power than G type.</p> <p>E.g: If you need 11kw P type, 7.5kw G type could be selected as a replacement. Its input current is the rated input current (20.5A) of 7.5kw G type, but its rated power is that of 11kw G type, and output current is the rated output current(25A) of 11kw G type.</p> <p>Though inverter hardware of GP unification is different, there are some optimization of software parameters for different load types .</p> <p>P type model is only suitable for pump, fan etc light load models, can not work at the rated current or more than the rated frequency for a long time.</p>
----------------------------------	---



### 3 Operation panel introduction

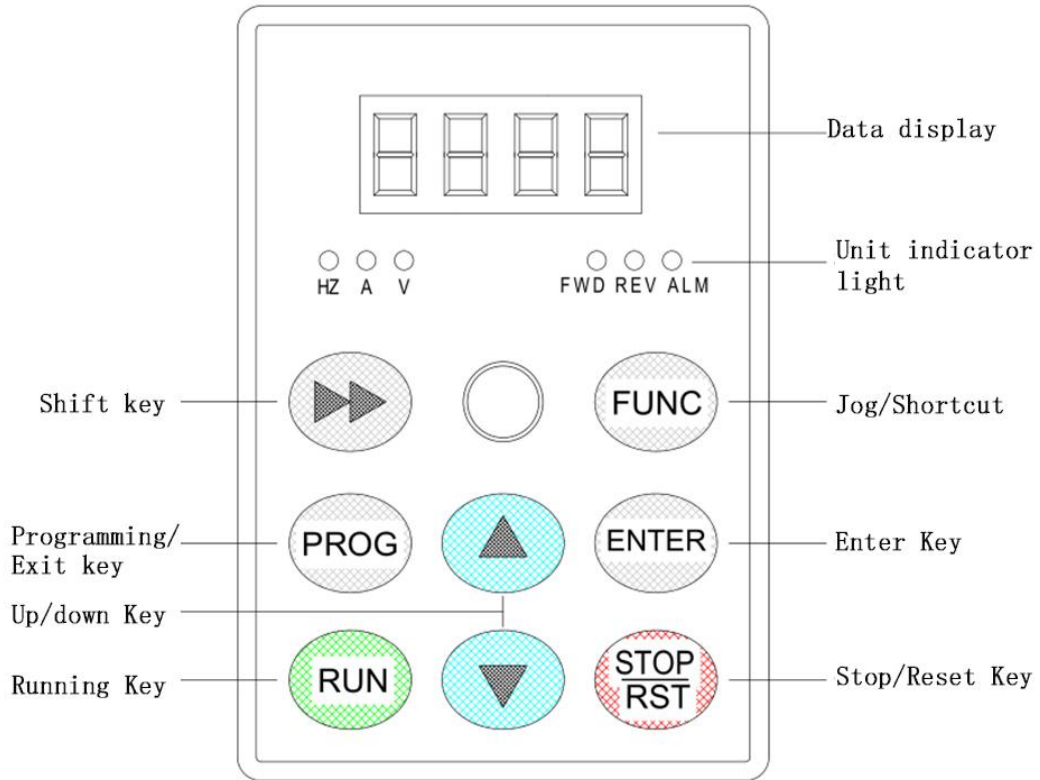

Panel indicator description		
Symbol	Name	Function
FWD	Forward indicator	The inverter is running forward,
REV	Reverse indicator	The inverter is running reverse.
ALM	Warning indicator	Lights up when the inverter failure
V	Voltage indicator	When the light is on, it means that the LED display content is voltage data
A	Current indicator	When the light is on, it means that the LED display content is current data
HZ	Frequency indicator	When the light is on, it means that the LED display content is frequency data

## 4 Peripheral equipment selection

For inverters of different power levels, the recommended values of air switch MCCB, contactor capacity and copper core insulated conductor cross-sectional area are shown in the table below

**Recommended table of inverter input and output wiring specifications**

Model	Incoming protection		Power cable		Signal line (mm <sup>2</sup> )
	Air switch MCCB	Contactor (A)	Power line (mm <sup>2</sup> )	Motor line (mm <sup>2</sup> )	
SY2000-0R7G-S2	16	10	1.5	1.5	≥0.5
SY2000-1R5G-S2	20	16	2.5	1.5	≥0.5
SY2000-2R2G-S2	32	20	4.0	2.5	≥0.5
SY2000-0R7G-4	10	10	1.0	1.0	≥0.5
SY2000-1R5G-4	16	10	1.0	1.0	≥0.5
SY2000-2R2G-4	16	10	1.5	1.5	≥0.5
SY2000-004G/5R5P-4	25	16	2.5	2.5	≥0.5
SY2000-5R5G/7.7P -4	32	25	4.0	4.0	≥0.5
SY2000-7R5G/11P-4	40	32	4.0	4.0	≥0.5
SY2000-011G/15P-4	63	40	6.0	6.0	≥0.5
SY2000-015G/018P-4	63	40	6.0	6.0	≥0.5
SY2000-018G/22P-4	100	63	10	10	≥0.5
SY2000-022G/30P-4	100	63	16	16	≥0.5
SY2000-030G/37P-4	125	100	25	25	≥0.5
SY2000-037G/45P-4	160	100	25	25	≥0.5
SY2000-045G/55P-4	200	125	35	35	≥0.5
SY2000-055G/75P-4	200	125	50	50	≥0.5
SY2000-075G/90P-4	250	160	70	70	≥0.5

## 5 Parameter monitor and fault record

Group d-Monitoring parameter group					
Code	Item	Description	Setting Range	Default Value	Amendment
d-00	Output frequency (Hz)	0.00~999.9Hz	0.1HZ	0.0Hz	◆
d-01	Setting frequency (Hz)	0.00~999.9Hz	0.1HZ	0.0Hz	◆
d-02	Output voltage (V)	0~999V	1V	0V	◆
d-03	Bus voltage (V)	0~999V	1V	0V	◆
d-04	Output current (A)	0.0~999.9A	0.1A	0A	◆
d-05	Motor speed (Krpm)	0~6Krpm	1Krpm	Model setting	◆
d-06	Analog input AVI (V)	0.00~10V	0.01V	0.00V	◆
d-07	Analog input ACI (mA)	0.00~20.00mA	0.01mA	0.00mA	◆
d-08	Analog output AO (V / mA)	0.00~10.00V/0.00-20.00mA	0.01V/0.01mA	0.00V/mA	◆
d-09	Reserved	-	-	0	◆
d-10	Pulse input frequency (KHz)	0.00~99.99KHz	0.01KHz	0.00KHz	◆
d-11	PID pressure feedback value	0.00~10.00V/0.00~99.99(MPa/Kg)	0.01V/(MPa/Kg)	0.00V/(MPa/Kg)	◆
d-12	Current count value	0~9999s	1s	0s	◆
d-13	Current timing value (s)	0~9999s	1s	0s	◆
d-14	Input terminal status (X1-X5)	0 ~1FH	1H	0H	◆
d-15	Output status (Y / R)	0 ~ 1H	1H	0H	◆
d-16	Module temperature (°C)	0.0~132.3°C	0.1°C	0.0	◆
d-17	Software upgrade date (year)	2010~2026	1	2017	◆
d-18	Software upgrade date (month, day)	0~1231	1	0914	◆
d-19	Second fault code	1~19	1	0	◆
d-20	Last fault code	1~19	1	0	◆
d-21	Output frequency at last fault (Hz)	0.00~999.9Hz	0.1HZ	0.0Hz	◆
d-22	Output current at the last fault (A)	0.0~999.9A	0.1A	0.0A	◆
d-23	Bus voltage at the latest fault (V)	0~999V	1V	0V	◆
d-24	Module temperature at last fault (°C)	0.0~132.3°C	0.1°C	0.0	◆
d-25	Inverter running cumulative time (h)	0~9999h	1h	1h	◆

d-26	Inverter status	0 ~ FFFFH 0: Run / Stop 1: Reverse / Forward 2: Jog 3: DC braking 4: Reserved 5: Overvoltage limit 6: Constant speed frequency down 7: Over-current limit 8 ~ 9: 00-zero speed / 01-acceleration / 10-deceleration / 11-constant speed 10: Overload pre-alarm 11: Reserved 12 ~ 13:Running command channel: 00-panel / 01-terminal / 10-reserved 14~15:Bus voltage status: 00-normal / 01-low voltage protection / 10-overpressure protection	1H	0H	◆
------	-----------------	--	----	----	---

Group E-Fault code			
Code	Description	fault cause	Solution
E0C1	Over-current during acceleration	The acceleration time is too short	Increase acceleration time
		Inverter power is too small	Adopt large power inverter
		Improper setting of V / F curve or torque boost	Adjust V / F curve or torque boost
E0C2	Over-current during deceleration	Deceleration time is too short	Increase deceleration time
		Inverter power is too small	Adopt large power inverter
E0C3	Over-current during constant speed	Low grid voltage	Check input power
		Abrupt or abnormal load	Check load or reduce sudden load
		Inverter power is too small	Adopt large power inverter
EHU1	Overvoltage during acceleration	Abnormal input voltage	Check input power
		Restart the rotating motor	Set to start after DC braking
EHU2	Overvoltage during deceleration	Deceleration time is too short	Increase deceleration time
		Abnormal input voltage	Check input power
EHU3	Overvoltage during constant speed	Abnormal input voltage	Check input power
EHU4	Over-voltage during shutdown	Abnormal input voltage	Check input power
ELU0	Under-voltage during operation	Input voltage is abnormal or the relay is disconnect	Check the power supply voltage or ask service from the manufacturer

ESC1	Power module failure	Inverter output short circuit or grounded	Check motor wiring
		Inverter instantaneous overcurrent	Refer to overcurrent solution
		Control board abnormal or serious interference	Ask service from the manufacturer
		Power device damage	Ask service from the manufacturer
E-OH	Radiator overheating	The ambient temperature is too high	Decrease ambient temperature
		Damaged fan	Replace the fan
		Clogged air duct	Dredge air duct
EOL1	Inverter overload	Improper setting of V / F curve or torque boost	Adjust V / F curve and torque boost
		The grid voltage is too low	Check grid voltage
		The acceleration time is too short	Increase acceleration time
		The motor is overloaded	Choose big power inverter
EOL2	Motor overload	Improper setting of V / F curve or torque boost	Adjust V / F curve and torque boost
		The grid voltage is too low	Check grid voltage
		The motor is locked or the load is too large	Check the load
		The motor overload protection factor is set incorrectly	Correctly set the motor overload protection factor
E-EF	External equipment fault	Fault input terminal of the external device is closed	Disconnect the fault input terminal of the external device and clear the fault (Attention to check the reason)
EPID	PID feedback disconnected	PID feedback circuit is loose	Check the feedback connection
		Feedback value is less than broken wire detection value	Adjust the detection input threshold
E485	RS485 communication fault	Does not match the baud rate of the host computer	Adjust the baud rate
		RS485 channel interference	Check whether the communication connection is shielded and whether the wiring is reasonable. If necessary, consider connecting parallel filter capacitors
		Communication timeout	Retry
ECCF	Current detection fault	Current sampling circuit fault	Ask service from the manufacturer
		Auxiliary power fault	
EEEP	EEPROM read and write fault	EEPROM fault	Ask service from the manufacturer
EPAO	Burst fault	Feedback pressure is less than low pressure detection threshold or greater than or equal to high pressure detection threshold	Check the feedback connection or adjust the detection high and low pressure threshold
EPOF	Dual CPU communication fault	CPU communication fault	Ask service from the manufacturer

## 6 Parameter summary and instructions

Parameter Description					
○ —Parameters that can be modified in any state					
× —Parameters that cannot be modified in running state					
◆ —Actual detection parameters, which cannot be modified					
◇ —Manufacturer parameters, which are limited to manufacturer modification, and users are prohibited					
Group F0-basic operating parameters					
Code	Item	Description	Setting range	Default Value	Amendment
F0.00	Power	Display current power	0.10~ 99.99KW	Model setting	◆
F0.01	Main controller software version	Display the current software version number	1.00~99.99	1.00	◆
F0.02	Running command channel selection	0: Panel command channel 1: Terminal command channel 2: Communication command channel	0~2	0	○
F0.03	Frequency setting selection	0: Panel potentiometer 1: Digital setting 1, panel ▲, ▼ key adjustment 2: Digital setting 2, terminal UP / DOWN adjustment 3: AVI analog setting (0 ~ 10V) 4: Combination setting 5: ACI setting (0 ~ 20mA) 6: Communication setting 7: Pulse setting Note: When combination setting chosen, the combination setting is selected in F1.15.	0~7	0	○
F0.04	Maximum output frequency	The maximum output frequency is the highest frequency that the inverter is allowed to output, and it is the benchmark for acceleration and deceleration settings.	MAX {50.0, 【F0.05】} ~ 999.9Hz	50.0Hz z	×
F0.05	Upper limit frequency	The operating frequency cannot exceed this frequency	MAX{0.1, 【F0.06】} ~ 【F0.04】	50.0Hz z	×
F0.06	Lower limit frequency	The operating frequency cannot be lower than this frequency	0.0~Upper limit	0.0Hz	×

			frequency								
F0.07	Processing when Lower limit frequency reaching	0: Zero speed operation 1: Run at the lower limit frequency 2: Stop	0~2	0	×						
F0.08	Digital setting of operating frequency	The value is the initial value of frequency digital setting	0.0~Upper limit frequency	10.0Hz	○						
F0.09	Digital frequency control	LED ones: power-off storage 0: save 1: Do not save LED tens: Keep down 0: Keep 1: Do not keep LED hundreds: UP / DOWN negative frequency adjustment 0:useless 1:useful LED thousands: PID, PLC frequency superposition selection 0: useless 1: F0.03+PID 2: F0.03+PLC	0000~2111	0000	○						
F0.10	acceleration time	The time required for the inverter to accelerate from 0 to the maximum output frequency									
F0.11	deceleration time	The time required for the inverter to decelerate from the maximum output frequency to 0 <table border="1" data-bbox="518 1473 893 1599"> <thead> <tr> <th>Model</th> <th>Defalut</th> </tr> </thead> <tbody> <tr> <td>0.75~4.0kW</td> <td>7.5s</td> </tr> <tr> <td>5.5~7.5KW</td> <td>15s</td> </tr> </tbody> </table>	Model	Defalut	0.75~4.0kW	7.5s	5.5~7.5KW	15s	0.1~999.9S 0.4~4.0KW 7.5S 5.5~7.5KW 15.0S	Model setting	○
Model	Defalut										
0.75~4.0kW	7.5s										
5.5~7.5KW	15s										
F0.12	Direction setting	0: Forward 1: Reverse 2: No reversal	0~2	0	○						
F0.13	V / F curve setting	0: Linear curve 1: Square curve 2: Multi-point VF curve	0~2	0	×						
F0.14	Torque boost	Manual torque boost, this setting is a percentage relative to the motor rated voltage; if F0.14 = 0.0, it is vector control.	0.0~30.0%	Model setting	○						

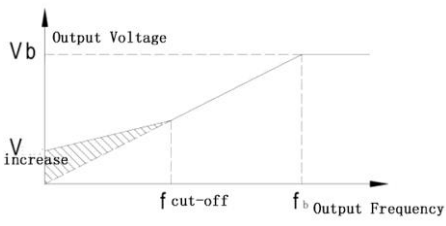
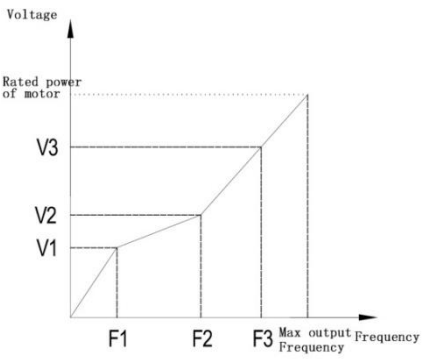
F0.15	Torque boost cutoff frequency	<p>This setting is the lifting cut-off frequency point during manual torque boost</p> 	0.0~50.0Hz	15.0Hz	×	
F0.16	Carrier frequency setting	<p>For occasions requiring silent operation, the carrier frequency can be appropriately increased to meet the requirements, but it will increase the heat generation of the inverter. When the inverter leaves the factory, the manufacturer has set a reasonable carrier frequency. Under normal circumstances, the user does not need to modify this parameter.</p>	2.0~16.0KHz z 0.4~3.0KW 4.0KHz 4.0~7.5KW 3.0KHz	Model setting	×	
F0.17	V/F frequency value F1		0.1~Frequency value F2	12.5Hz	×	
F0.18	V/F voltage value V1		0.0~Voltage value V2	25.0%	×	
F0.19	V/F frequency value F2		Frequency value F1 ~ frequency value F3	25.0Hz	×	
F0.20	V/F voltage value V2		Voltage value V1 ~ voltage value V3	50.0%	×	
F0.21	V/F frequency value F3		<p>When P0.13=2 (multi-point V/F curve), users can use F0.17~F0.22 V/F curve. The V/F curve is usually set according to the load characteristics of the motor. Note: V1&lt;V2&lt;V3, F1&lt;F2&lt;F3, the low frequency voltage setting is too high may cause the motor to overheat or even burn, the inverter may be over current stall or over current protection.</p>	Frequency value F2~motor rated frequency 【F4.03】	37.5Hz	×
F0.22	V/F voltage value V3		Voltage value V2 ~ 100.0% * Vout (motor rated voltage [F4.00])	75.0%	×	
F0.23	user password		Set any non-zero number, you need to wait 3 minutes or power down to take effect.	0~9999	0	○



Group F1-auxiliary operating parameters					
Code	Item	Description	Setting range	Default Value	Amendment
F1.00	Starting method	LED ones: starting mode 0: starting from the starting frequency 1: DC braking first and then starting from the starting frequency LED tens: Power failure or abnormal restart method 0: useless 1: starting from the starting frequency LED hundreds: reserved LED thousands: reserved	0000~0011	00	×
F1.01	Direct Starting frequency	Direct starting frequency: refers to the initial frequency when the inverter starts.	0.0~50.0Hz	1.0Hz	○
F1.02	DC braking current at starting	Starting DC braking current and time: When the inverter starts, perform DC braking according to the set DC braking current before starting, and then start the acceleration operation after the set DC braking time before starting. If the DC braking time is set to 0, the DC braking is invalid. The greater the DC braking current, the greater the braking force.	0.0~50.0% × Motor rated current	0.0%	○
F1.03	DC braking time at starting	The DC braking current before starting refers to the percentage of the rated current of the inverter. 	0.0~30.0s	0.0s	○
F1.04	Stop mode	0: Slow down 1: Free stop	0~1	0	×

F1.05	Starting frequency of DC braking at stop		0.0~Upper limit frequency	0.0Hz	○
F1.06	Voltage of DC braking at stop		0.0~50.0% × Motor rated voltage	0.0%	○
F1.07	DC braking time at stop		0.0~30.0s	0.0s	×
F1.08	DC braking waiting time at stop		0.00~99.99s	0.00s	×
F1.09	forward Jog frequency setting	Jog forward and reverse frequency setting	0.0~50.0Hz	10.0Hz	○
F1.10	Reverse jog frequency setting				
F1.11	Jog acceleration time	Jog acceleration and deceleration time setting	0.1~999.9S 0.4~4.0KW 10.0S 5.5~7.5KW 15.0S	Model setting	○
F1.12	Jog deceleration time				
F1.13	Jump frequency	By setting the jump frequency and range, the inverter can avoid the mechanical resonance point of the load.	0.0~Upper limit frequency	0.0Hz	○
F1.14	Jump range		0.0~10.0Hz	0.0Hz	○
F1.15	Combination frequency setting method	0: Potentiometer + digital frequency 1: Potentiometer + digital frequency 2: Potentiometer + AVI 3: Digital frequency 1 + AVI 4: Digital frequency 2 + AVI 5: Digital frequency 1+ multi-speed 6: Digital frequency 2+ multi-speed 7: Potentiometer + multi-speed	0~7	0	×
F1.16	Programmable operation control (simple PLC operation)	LED ones: PLC enable control 0: useless 1: useful LED tens: Operating mode selection 0: Single cycle 1: Continuous cycle 2: Keep the final value after a single cycle LED hundreds: Starting method 0: Restart from the first stage 1: Start from the stage of shutdown (fault) moment 2: Start from the stage , frequency at the moment of shutdown (fault)	0000~1221	0000	×

		LED thousands: Power-down storage options 0: storage 1: do not storage																																		
F1.17	Multi-speed frequency 1	F1.17-P1.35 to determine the operating frequency, time and direction of each section. The multi-step speed frequency can be set continuously from -upper limit frequency (-fmax) to upper limit frequency (fmx). Note: The sign of the multi-step speed determines the running direction of the simple PLC. Negative values indicate reverse operation. This machine can set 7-step speed frequency, corresponding to multi-step speed frequency 0 (f0) to multi-step speed 6 (f6)	-Upper frequency to upper frequency	5.0Hz	○																															
F1.18	Multi-speed frequency 2		-Upper frequency to upper frequency	10.0Hz	○																															
F1.19	Multi-speed frequency 3		-Upper frequency to upper frequency	15.0Hz	○																															
F1.20	Multi-speed frequency 4		-Upper frequency to upper frequency	20.0Hz	○																															
F1.21	Multi-speed frequency 5		-Upper frequency to upper frequency	25.0Hz	○																															
F1.22	Multi-speed frequency 6		-Upper frequency to upper frequency	37.5Hz	○																															
F1.23	Multi-speed frequency 7		-Upper frequency to upper frequency	50.0Hz	○																															
		<table border="1"> <thead> <tr> <th>Speed segment</th> <th>Multi-speed S1</th> <th>Multi-speed S2</th> <th>Multi-speed S3</th> </tr> </thead> <tbody> <tr> <td>0</td> <td>1</td> <td>0</td> <td>0</td> </tr> <tr> <td>1</td> <td>0</td> <td>1</td> <td>0</td> </tr> <tr> <td>2</td> <td>1</td> <td>1</td> <td>0</td> </tr> <tr> <td>3</td> <td>0</td> <td>0</td> <td>1</td> </tr> <tr> <td>4</td> <td>1</td> <td>0</td> <td>1</td> </tr> <tr> <td>5</td> <td>0</td> <td>1</td> <td>1</td> </tr> <tr> <td>6</td> <td>1</td> <td>1</td> <td>1</td> </tr> </tbody> </table>	Speed segment	Multi-speed S1	Multi-speed S2	Multi-speed S3	0	1	0	0	1	0	1	0	2	1	1	0	3	0	0	1	4	1	0	1	5	0	1	1	6	1	1	1		
Speed segment	Multi-speed S1	Multi-speed S2	Multi-speed S3																																	
0	1	0	0																																	
1	0	1	0																																	
2	1	1	0																																	
3	0	0	1																																	
4	1	0	1																																	
5	0	1	1																																	
6	1	1	1																																	
F1.24	Speed segment 1 running time	Set the running time of segment speed 1 (unit is selected by [F1.35], default is second)	0.0~999.9s	10.0s	○																															
F1.25	Speed segment 2 running time	Set the running time of segment speed 2 (the unit is selected by [F1.35], the default is second)	0.0~999.9s	10.0s	○																															
F1.26	Speed segment 3 running time	Set the running time of segment speed 3 (the unit is selected by [F1.35], the default is second)	0.0~999.9s	10.0s	○																															
F1.27	Speed segment 4 running time	Set the running time of segment speed 4 (unit is selected by [F1.35], default is second)	0.0~999.9s	10.0s	○																															
F1.28	Speed segment 5 running time	Set the running time of segment speed 5 (the unit is selected by [F1.35], the default is second)	0.0~999.9s	10.0s	○																															
F1.29	Speed segment 6 running time	Set the running time of segment speed 6 (unit is selected by [F1.35], default is second)	0.0~999.9s	10.0s	○																															
F1.30	Speed segment 7 running time	Set the running time of segment speed 7 (the unit is selected by [F1.35], the default is second)	0.0~999.9s	10.0s	○																															
F1.31	segment acceleration and deceleration	LED ones: Speed segment 1 acceleration and deceleration time 0 ~ 1	0000~1111	0000	○																															

	time selection 1	LED tens: Speed segment 2 acceleration and deceleration time 0 ~ 1 LED Hundreds : Speed segment 3 acceleration and deceleration time 0 ~ 1 LED Thousands: Speed segment 4 acceleration and deceleration time 0 ~ 1			
F1.32	segment acceleration and deceleration time selection 1	LED ones: Speed segment 5 acceleration and deceleration time 0 ~ 1 LED tens: Speed segment 6 acceleration and deceleration time 0 ~ 1 LED Hundreds : Speed segment 7 acceleration and deceleration time 0 ~ 1 LED Thousands: reserved	000~111	000	○
F1.33	Acceleration time 2	Set acceleration and deceleration time 2	0.1~999.9s 0.4~4.0KW 10.0s 5.5~7.5KW 15.0s	10.0s	○
F1.34	deceleration time 2				
F1.35	Time unit selection	LED ones: process PID time unit LED Tens: simple PLC time unit LED Hundreds :general acceleration and deceleration time unit LED Thousands: reserved 0: unit is 1 second 1: unit is 1 minute 1: unit is 0.1 second	000~211	000	×

**Group F2-Analog and digital input and output parameters**

Code	Item	Description	Setting range	Default Value	Amendment
F2.00	AVI input lower limit voltage	Set AVI upper and lower voltage limits	0.00~ 【F2.01】	0.00V	○
F2.01	AVI input upper limit voltage		【F2.01】 ~ 10.00V	10.00V	○
F2.02	AVI lower limit corresponding setting	Set the corresponding setting of AVI upper and lower limits, this setting corresponds to the percentage of upper limit frequency [F0.05].	-100.0% ~ 100.0%	0.0%	○
F2.03	AVI upper limit corresponding setting			100.0%	○
F2.04	ACI input lower limit current	Set ACI input upper and lower current limit	0.00~ 【F2.05】	0.00mA	○
F2.05	ACI input upper limit current		【F2.04】 ~ 20.00mA	20.00mA	○
F2.06	ACI lower limit corresponding setting	Set the corresponding setting of the upper and lower limits of ACI, which corresponds to the percentage of upper	-100.0% ~ 100.0%	0.0%	○

F2.07	ACI upper limit corresponding setting	limit frequency [F0.05].		100.0 %	○
F2.08	Analog input signal filtering time constant	This parameter is used to filter the input signal of AVI, ACI and panel potentiometer to eliminate the influence of interference.	0.1~5.0s	0.1s	○
F2.09	Analog input anti-shake deviation limit	When the analog input signal frequently fluctuates around the given value, you can set F2.09 to suppress the frequency fluctuation caused by this fluctuation.	0.00~0.10V	0.00V	○
F2.10	AO analog output terminal function selection	0: output frequency 1: output current 2: Motor speed 3: output voltage 4: AVI 5: ACI	0~5	0	○
F2.11	AO output lower limit	Set the upper and lower limits of AFM output	0.00~10.00 V/	0.00V	○
F2.12	AO output upper limit		0.00~20.00 mA	10.00 V	○
F2.13	Input terminal X1 function	0: The control terminal is in idle 1: Forward jog control 2: Reverse jog control 3: Forward control (FWD) 4: Reverse control (REV) 5: Three-wire operation control 6: Free stop control 7: External stop signal input (STOP) 8: External reset signal input (RST) 9: Normally open input for external fault 10: Frequency increasing command (UP) 11: Frequency decreasing command (DOWN) 13: Multi-speed selection S1 14: Multi-speed selection S2 15: Multi-step speed selection S3 16: Run command channel is forced to be terminal 17: Run command channel is forced to be communication 18: Stop DC braking command 19: Frequency switch to AVI 20: Frequency switch to digital frequency 1 21: Frequency switch to digital frequency 2 22: Pulse frequency input (only valid for X5) 23: Counter clear signal 24: Counter trigger signal 25: Timer clear signal 26: Timer trigger signal 27: Acceleration and deceleration time selection	0~27	3	×
F2.14	Input terminal X2 function		0~27	4	×
F2.15	Input terminal X3 function		0~27	0	×
F2.16	Input terminal X4 function		0~27	0	×
F2.17	Input terminal X6 function		0~27	22	×
F2.18	FWD / REV	0: Two-wire control mode 1	0~3	0	×

	terminal control mode	1: Two-wire control mode 2 2: Three-wire control mode 1 3: Three-wire control mode 2			
F2.19	Terminal function detection selection at power-on	0: terminal running command is invalid when power on 1: terminal running command is valid when power on	0~1	0	×
F2.20	Relay TA/TB/TC Output settings	0: In idle 1: The inverter is ready for operation 2: Inverter is running	0~14	5	○
F2.21	Y1 open collector output	3: The inverter is running at zero speed 4: External fault shutdown 5: Inverter failure 6: Frequency / speed arrival signal (FAR) 7: Frequency / speed level detection signal (FDT) 8: The output frequency reaches the upper limit 9: The output frequency reaches the lower limit 10: inverter overload pre-alarm 11: Timer overflow signal 12: Counter detection signal 13: Counter reset signal 14: Auxiliary motor	0~14	0	○
F2.22	Relay TA/TC closing delay	The delay from the change of relay state to the change of output	0.0~255.0s	0.0s	×
F2.23	Relay TA/TC closing delay				
F2.24	Frequency reach FAR detection amplitude	The output frequency is within the positive and negative detection width of the set frequency, and the terminal outputs a valid signal (low level).	0.0Hz~15.0 Hz	5.0Hz	○
F2.25	FDT level setting	When the output frequency exceeds the frequency corresponding to the PDT level, the multi-function digital output terminal outputs the "frequency level detection FDT" signal [F2. 20~F2.21] until the output frequency drops below ) The signal is invalid only at the corresponding frequency. The specific waveform is shown below:	0.0Hz~Upper limit frequency	10.0Hz	○
F2.26	FDT hysteresis		0.0~30.0Hz	1.0Hz	○

F2.27	UP / DOWN terminal modification rate	The function code is the frequency modification rate when setting the frequency by the UP / DOWN terminal, that is, the UP / DOWN terminal and the COM terminal are shorted for one second, and the amount of frequency change	0.1Hz~99.9 Hz/s	1.0Hz/s	○
F2.28	Input terminal pulse trigger mode setting (X1~X5)	0: indicates the level trigger mode 1: indicates pulse trigger mode	0~1FH	0	○
F2.29	Input terminal effective logic setting (X1 ~ X5)	0: Positive logic, that is, When Xi terminal connected to the public terminal, it is valid, and the disconnection is invalid 1: Inverse logic, that is, When Xi terminal connected and public terminal, it is invalid, and the disconnection is valid	0~1FH	0	○
F2.30	X1 filter coefficient	Used to set the sensitivity of the input terminal. If the digital input terminal is susceptible to interference and causes malfunction, the parameter can be increased to increase the anti-interference ability, but if the setting is too large, the sensitivity of the input terminal will be reduced. 1: represents 2MS scanning time unit	0~9999	5	○
F2.31	X2 filter coefficient		0~9999	5	○
F2.32	X3 filter coefficient		0~9999	5	○
F2.33	X4 filter coefficient		0~9999	5	○
F2.34	X5 filter coefficient		0~9999	5	○
<b>Group F3-PID parameters</b>					
Code	Item	Description	Setting range	Default Value	Amendment
F3.00	PID function setting	LED ones: PID adjustment characteristic 0: invalid 1: positive effect When the feedback signal is greater	0000~2122	1010	×

		<p>than the given amount of PID, the output frequency of the inverter is required to decrease (that is, to reduce the feedback signal).</p> <p>2: Negative effect</p> <p>When the feedback signal is greater than the given amount of PID, the output frequency of the inverter is required to increase (ie, reduce the feedback signal).</p> <p>LED hundreds: PID given input channel</p> <p>0: keyboard potentiometer</p> <p>The PID amount is given by the potentiometer on the operation panel.</p> <p>1: Digital setting</p> <p>The PID amount is given by digital input and set by function code F3.01.</p> <p>2: Pressure setting (MPa, Kg)</p> <p>Set pressure by setting F3.01 and F3.18.</p> <p>LED Hundreds: PID feedback input channel</p> <p>0: AVI</p> <p>1: ACI</p> <p>LED thousands : PID sleep selection</p> <p>0: invalid</p> <p>1: Normal sleep</p> <p>This method needs to set specific parameters of F3.10 ~ F3.13.</p> <p>2: Disturb sleep</p> <p>It is the same as the parameter setting when the sleep mode is selected as 0. If the PID feedback value is within the range set by F3.14, it will enter to the disturbance sleep after maintaining the sleep delay time. If the feedback value is less than the wake-up threshold (PID polarity is positive), it will wake up immediately.</p>			
F3.01	Digital setting of Given value	Use the operation keyboard to set the given value of PID control. This function is valid only when the digital setting of the PID given channel selects digital setting (F3.00 tens place is 1 or	0.0~100.0%	0.0%	○



		2). If the tens place of F3.00 is 2, it is given by pressure. This parameter is consistent with the unit of F3.18.			
F3.02	Feedback channel gain	When the level of the feedback channel and the set channel are inconsistent, this function can be used to adjust the gain of the feedback channel signal.	0.01~10.00	1.00	○
F3.03	Proportional gain P	The speed of PID adjustment speed is set by the two parameters of proportional gain and integration time. If fast adjustment speed asked, it needs to increase the proportional gain and reduce the integration time. If slow adjustment speed asked, it needs to reduce the proportional gain and increase the integration time. In general, the derivative time is not set.	0.01~5.00	2.00	○
F3.04	Integration time Ti		0.1~50.0s	1.0s	○
F3.05	Differential time Td		0.1~10.0s	0.0s	○
F3.06	Sampling period T	The larger the sampling period, the slower the response, but the better the suppression effect of the interference signal, it is not necessary to set it under normal circumstances.	0.1~10.0s	0.0s	○
F3.07	Deviation limit	The deviation limit is the ratio of the absolute value of the deviation between system feedback amount and the given amount to the given amount. When the feedback amount is within the deviation limit range, the PID adjustment does not work.	0.0~20.0%	0.0%	○
F3.08	Closed loop preset frequency	Frequency and running time of inverter before PID operation	0.0~Upper limit frequency	0.0Hz	○
F3.09	Preset frequency retain time		0.0~999.9s	0.0s	×
F3.10	Sleep threshold coefficient	If the actual feedback value is greater than the given value, and when the frequency output by the inverter reaches the lower limit frequency, the inverter enters the sleep state (ie, running at zero speed) after the delay waiting time defined by F3.12; The value is the percentage of PID setting.	0.0~150.0%	100.0%	○
F3.11	Wake up	If the actual feedback value is less than	0.0~150.0%	90.0%	○

	threshold coefficient	the given value, the inverter will leave the sleep state and start working after the delay waiting time defined by F3.13; this value is the percentage of the PID set value.			
F3.12	Sleep delay time	Set sleep delay time	0.0~999.9s	100.0s	○
F3.13	Wake up delay time	Set wake up delay time	0.0~999.9s	1.0s	○
F3.14	The deviation between the feedback when entering sleep and the set pressure	This function parameter is only valid for disturbance sleep mode	0.0~10.0%	0.5%	○
F3.15	Pipe Burst detection delay time	Set delay time of the pipe burst detection	0.0~130.0s	30.0S	○
F3.16	High pressure detection threshold	When the feedback pressure is greater than or equal to this set value, the burst pipe fault "EPA0" will be reported after F3.15 burst pipe delay. When the feedback pressure is less than this set value, the burst pipe fault "EPA0" will be automatically reset; the threshold is the percentage of constant pressure.	0.0~200.0%	150.0%	○
F3.17	Low pressure detection threshold	When the feedback pressure is less than this set value, the burst pipe fault "EPA0" will be reported after F3.15 burst pipe delay. When the feedback pressure is greater than or equal to this set value, the burst pipe fault "EPA0" will be automatically reset; the threshold is The percentage of constant pressure.	0.0~200.0%	50.0%	○

F3.18	Sensor range	Set the maximum range of the sensor	0.00~99.99 (MPa, Kg)	10.00 MPa	○
<b>Group F4-Advanced function parameters</b>					
Code	Item	Description	Setting range	Default Value	Amendment
F4.00	Motor rated voltage	Motor parameter setting	0~500V: 3 80V 0~250V: 2 20V	Model setting	×
F4.01	Motor rated current		0.1~999.9A	Model setting	×
F4.02	Motor rated speed		0~60000Krpm	Model setting	×
F4.03	Motor rated frequency		1.0~999.9Hz	50.0Hz	×
F4.04	Motor stator resistance	Set motor stator resistance	0.001~20.00 0Ω	Model setting	○
F4.05	Motor no-load current	Set motor no-load current	0.1~【F4.01】	Model setting	×
F4.06	AVR function	0: invalid 1: valid throughout 2: Only invalid when decelerating	0~2	0	×
F4.07	Cooling fan control	0: Automatic control mode 1: Keep running when the power on.	0~1	0	○
F4.08	Fault automatic reset times	When the number of fault resets is set to 0, there is no automatic reset function, which can only be reset manually. 10 means that the number of times is unlimited, that is, countless times.	0~10	0	×
F4.09	Fault automatic reset interval time	Set the interval time of fault automatic reset	0.5~25.0s	3.0s	×
F4.10	Starting voltage of Energy consumption braking	If the internal DC voltage of the inverter is higher than the initial voltage of energy consumption braking, the built-in braking unit will act. If a braking resistor is connected at this time, the internally raised voltage energy of the inverter will be released through the braking resistor to make the DC voltage drop.	330~380/66 0~800V	350/78 0V	○
F4.11	Ratio of energy consumption braking action		10~100%	100%	○
<b>Group F5-protection function parameters</b>					
Code	Item	Description	Setting range	Default Value	Amendment
F5.00	Protection settings	LED ones: Motor overload protection selection 0: invalid 1: valid LED tens: PID feedback disconnection protection 0: invalid 1: Protective action and free stop LED Hundreds: 485 communication failure processing 0: Protective action and free stop	0000~1211	0001	×

		1: Alarm but maintain the status quo operation 2: Alarm and stop according to the set method LED Thousands : Shock suppression selection 0: invalid 1: valid			
F5.01	Motor overload protection factor	The motor overload protection factor is the percentage of the motor rated current value to the inverter rated output current value	30%~110%	100%	×
F5.02	Undervoltage protection level	This function code specifies the allowable lower limit voltage of the DC bus when the inverter is working normally.	50~280/50~480V	180/360V	×
F5.03	Deceleration voltage limit factor	This parameter is used to adjust the inverter's ability to suppress overvoltage during deceleration.	0: close, 1~255	1	×
F5.04	Overvoltage limit level	The overvoltage limit level defines the operating voltage during overvoltage stall protection	350~400/660~850V	375/790V	×
F5.05	Acceleration current limit factor	This parameter is used to adjust the inverter's ability to suppress overcurrent during acceleration.	0: close, 1~99	10	×
F5.06	Constant speed current limiting factor	This parameter is used to adjust the inverter's ability to suppress overcurrent during constant speed operation	0: close, 1~10	0	×
F5.07	Current limit level	The current limiting level defines the current threshold of the automatic current limiting action, and its set value is a percentage relative to the rated current of the inverter.	50%~250%	180%	×
F5.08	Feedback disconnection detection value	This value is the percentage of PID given amount. When the feedback value of PID continues to be smaller than the feedback disconnection detection value, the inverter will make corresponding protection actions according to the setting of F5.00, and it will be invalid when F5.08 = 0.0%.	0.0~100.0%	0.0%	×
F5.09	Feedback disconnection detection time	The delay time before the protection action after feedback disconnection occurs.	0.1~999.9S	10.0s	×
F5.10	Inverter overload pre-alarm level	The current threshold of the inverter overload pre-alarm action is set as a percentage of the inverter's rated current.	0~150%	120%	○
F5.11	Inverter overload pre-alarm delay	The delay time between the inverter output current and the overload pre-alarm level (F5.10) to the output of the overload pre-alarm signal. The delay time from the output current of the inverter is continuously greater than the overload pre-alarm level (F5.10) to the output of the overload	0.0~15.0s	5.0s	×

		pre-alarm signal.			
F5.12	Jog priority enable	0: Invalid 1: When the inverter is running, the jogging priority is the highest	0~1	0	×
F5.13	Oscillation suppression factor	When motor vibration occurs, it is necessary to set F5.00 thousands to be effective, turn on the vibration suppression function, and then adjust by setting the vibration suppression coefficient. In general, if the vibration amplitude is large, increase the vibration suppression coefficient F5.13, F5.14 ~ F5.16 does not need to be set; if special occasions, F5.13 ~ F5.16 should be used together.	0~200	30	○
F5.14	Amplitude suppression factor		0~12	5	○
F5.15	Lower limit frequency of oscillation suppression		0.0~【F5.16】	5.0Hz	○
F5.16	Upper limit frequency of oscillation suppression		【F5.15】~【F0.05】	45.0Hz	○
F5.17	Wave-by-wave current limit selection	LED ones: select when acceleration 0: invalid 1: valid LED tens digit: select when deceleration 0: invalid 1: effective LED hundreds o: select when constant speed 0: invalid 1: valid LED thousands: reserved	000~111	011	×
<b>Group F6-Communication parameters</b>					
Code	Item	Description	Setting range	Default Value	Amendment
F6.00	Local address	Set the local address, 0 is the broadcast address.	0~247	1	×
F6.01	MODBUS communication configuration	LED ones: baud rate selection 0: 9600BPS 1: 19200BPS 2: 38400BPS LED tens: data format 0: no check 1: Even parity 2: Odd parity LED hundreds: communication response mode 0: normal response 1: Only respond to slave address 2: No response 3: The slave does not respond to the free stop command of the master in the broadcast mode LED thousands: reserved	0000~0322	0000	×
F6.02	Communication timeout detection time	If the machine does not receive the correct data signal within the time interval defined by this function code, then the machine considers that the communication has failed, and the	0.1~100.0s	10.0s	×

		inverter will decide whether to protect or maintain the current operation according to the setting of the communication failure action mode. When the value is set to 0.0, RS485 communication timeout detection is not performed.			
F6.03	Local response delay	This function code defines the end of the inverter data frame reception and sends the intermediate time interval of the response data frame to the host computer. If the response time is less than the system processing time, the system processing time shall prevail.	0~200ms	5ms	×
F6.04	Proportional linkage coefficient	This function code is used to set the weight coefficient of the frequency command received by the inverter through the RS485 interface which as the slave The actual operating frequency of this machine is equal to the value of this function code times the frequency setting command value received through the RS485 interface. In linkage control, this function code can set the ratio of the operating frequency of multiple inverters.	0.01~10.00	1.00	○

**Group F7-supplementary functional parameters**

Code	Item	Description	Setting range	Default Value	Amendment
F7.00	Counting and timing mode	LED ones: count arrival processing 0: Single period counting, stop output 1: Single period, continue to output 2: Cycle count, stop output 3: Cycle count, continue to output LED Tens: reserved LED hundreds: timing arrival processing 0: Single-week timing, stop output 1: Weekly timing, continue to output 2: Cycle timing, stop output 3: Cycle timing, continue to output LED thousands: reserved	000~303	103	×
F7.01	Counter reset value setting	Set counter reset value	【F7.02】 ~ 9999	1	○
F7.02	Counter detection value setting	Set counter detection value	0~ 【F7.01】	1	○
F7.03	Timing setting	Set timing time	0~9999s	0s	○
F7.04	External pulse X5 input lower limit frequency	Set external pulse X5 input upper and lower limit frequency	0.00~ 【F7.14】	0.00K Hz	○
F7.05	External pulse X5 input upper limit frequency		【F7.13】 ~ 99.99KHz	20.00 KHz	○
F7.06	External pulse X5 lower limit	Set the external pulse X5 upper and lower limit corresponding settings, this	-100.0% ~ 10 0.0%	0.0%	○

	corresponding setting	setting is a percentage relative to the maximum output frequency			
F7.07	External pulse X5 upper limit corresponding setting		-100.0% ~ 100.0%	100.0%	○
<b>Group F8-Management and display parameters</b>					
Code	Item	Description	Setting range	Default Value	Amendment
F8.00	Operation monitoring parameter selection	For example: F8.00 = 2, that is, select the output voltage (d-02), and then the default display item of the main monitoring interface is the current output voltage value.	0~26	0	○
F8.01	Selection of shutdown monitoring parameter items	For example: F8.01 = 3, that is, select the bus voltage (d-03), and then the default display item of the main monitoring interface is the current bus voltage value.	0~26	1	○
F8.02	Motor speed display coefficient	It is used to correct the display error of the speed scale and has no effect on the actual speed.	0.01~99.99	1.00	○
F8.03	Parameter initialization	0: No operation The inverter is in the normal parameter reading and writing state. Whether the setting value of the function code can be changed depends on the setting state of the user password and the current working state of the inverter. 1: Restore factory settings All user parameters are restored to factory settings according to the model. 2: Clear fault record Clear the contents of the fault record (d-19 ~ d-24). After the operation is completed, this function code is automatically cleared to 0.	0~2	0	×
F8.04	JOG key setting	0: JOG 1: switching between forward and reverse 2: Clear the ▲ / ▼ key frequency setting 3: Reverse running (at this time, the RUN key defaults to forward running)	0~3	0	×
F8.05	Slip compensation selection	0: invalid 1: valid After the asynchronous motor is loaded, it will cause the speed to drop. The use of slip compensation can make the motor speed close to its synchronous speed, so that the motor speed control accuracy is higher.	0~1	0	×

# 7 Communication Protocol

(The following data are all hexadecimal)

## 1、RTU mode and format

When the controller communicates on the Modbus bus in RTU mode, each 8-bit byte in the information is divided into two 4-bit hexadecimal characters. The main advantage of this mode is that the density of characters transmitted is higher than that of ASCII mode at the same baud rate, each message must be transmitted continuously.

### (1) The format of each byte in RTU mode

Coding system: 8-bit binary, hex 0-9, A-F.

Data bits: 1 start bit, 8 bits of data (lowest bit sent first), 1 stop bit, parity bit can be selected.

(Refer to RTU data frame bit sequence diagram)

Error check area: cyclic redundancy check (CRC).

### (2) RTU data frame bit sequence diagram

With Parity check

Start	1	2	3	4	5	6	7	8	Par	Stop
-------	---	---	---	---	---	---	---	---	-----	------

Without Parity check

Start	1	2	3	4	5	6	7	8	Stop
-------	---	---	---	---	---	---	---	---	------

## 2、Reading and writing function code description:

Function code	Function description
03	Read register
06	Write register

## 3、Parameter address description of communication protocol:

Function Description	Address definition	Explanation of data	R/W
Communication control commands	2000H	0001H: Downtime	W
		0012H: Forward run	
		0013H: Jog forward	
		0022H: Reverse run	
		0023H: Jog reverse	
Communication frequency setting address	2001H	The communication frequency setting range is -10000 ~ 10000. Note: The communication frequency setting is a percentage relative to the maximum frequency, and its range is -100.00% ~ 100.00%).	W
Communication control commands	2002H	0001H: External fault input	W
		0002H: Fault reset	



Read run / stop parameters	2102H	Set frequency (two decimal places)	R
	2103H	Output frequency (two decimal places)	R
	2104H	Output current (one decimal places)	R
	2105H	Bus voltage (one decimal places)	R
	2106H	The output voltage(one decimal places)	R
	210DH	Inverter temperature (one decimal places)	R
	210EH	PID Feedback value (two decimal places)	R
	210FH	PID Given value (two decimal places)	R
	2101H	Bit0: run Bit1: Downtime Bit2: Jog Bit3: Forward Bit4: Reverse Bit5~Bit7: reserved Bit8: Communication given Bit9: Analog signal input Bit10 : Communication operation command channel Bit11: Parameter lock Bit12: Running Bit13: Jog command Bit14~Bit15: reserved	R
Read fault code description	2100H	00: No abnormality 01: Module failure 02: Overvoltage 03: Temperature failure 04: Inverter overload 05: Motor overload 06: External fault 07~09: Reserved 10: Overcurrent during acceleration 11: Overcurrent during deceleration 12: Overcurrent at constant speed 13: Reserved 14: Undervoltage	R

#### 4、03 Reading function mode:

Inquiry information frame format (Send frame):

Address	01H
Function	03H
Starting data address	21H
	02H
Data(2Byte)	00H
	02H
CRC CHK Low	6FH
CRC CHK High	F7H

Data analysis:

- 01H Inverter address
- 03H Function code
- 2102H Starting address
- 0002H To read the number of addresses, I.e. 2102H and 2103H
- F76FH 16-bit CRC check code

Response information frame format(Return frame):

Address	01H
Function	03H
DataNum*2	04H
Data1[2Byte]	17H
	70H
Data2[2Byte]	00H
	00H
CRC CHK Low	FEH
CRC CHK High	5CH

Data analysis:

- 01H Inverter address
- 03H Reading function code.
- 04H Is the product of reading items \* 2
- 1770H Read the data of 2102H (set frequency)
- 0000H Read the data of 2103H (output frequency)
- 5CFEH 16-bit CRC check code

## 5、06H Writing function mode

Inquiry information frame format(Sending frame):

Address	01H
Function	06H
Starting data address	20H
	00H
Data(2Byte)	00H
	01H
CRC CHK Low	43H
CRC CHK High	CAH

Data analysis:

- 01H Inverter address
- 06H Writing function code
- 2000H Control command address
- 0001H Stop command
- 43CAH 16-bit CRC check code

Response information frame format(Return frame):

Address	01H
Function	06H
Starting data address	20H
	00H
Number of Data(Byte)	00H
	01H
CRC CHK Low	43H
CRC CHK High	CAH

Data analysis of this segment: If the settings are correct, return the same input data.

## 8 Regular inspection and maintenance

Changes in the operating environment of the inverter, such as the effects of temperature, humidity, smoke, and the aging of internal components of the inverter, may cause various failures of the inverter. Therefore, the inverter must be inspected daily during storage and use, and regular maintenance should be carried out.

1: Daily maintenance

When the inverter is turned on normally, please confirm the following:

- (1) Does the motor have abnormal sound and vibration?
- (2) Is the inverter and motor overheated abnormally?
- (3) Is the ambient temperature too high?
- (4) Is the load current meter the same as usual.

(5) Is the cooling fan of the inverter running normally?。

## 2: Regular maintenance

### 1) Regular maintenance

The user can conduct regular inspections of the inverter in the short-term or 3-6 months according to the usage, to eliminate hidden troubles and ensure long-term stable operation. When the inverter checked, the power must be cut off. Only After the monitor is not displayed and the power indicator of the main circuit is off, the inspection can be carried out

(1) If the control terminal screws are loose, tighten them with a screwdriver.

(2) Whether the main circuit terminals are in poor contact, and whether there are traces of overheating in the connections of cables or copper bars, screws。

(3) Whether the power cable and control wire are damaged, especially whether the external insulation layer is cracked or cut.

(4) Whether the connection between the power cable and the cold-pressed connector is loose, and whether the insulation explosion zone at the connection is aging or falling off.

(5) Clean up dust on printed circuit boards, air ducts, etc., and take anti-static measures when cleaning.

(6) For the insulation test of the inverter, you must first remove the power supply of the inverter and all the connections between the inverter and the motor, and after all the main circuit input and output terminals are reliably shorted with wires, then test the ground, please Use a qualified 500V megohmmeter (or the corresponding voltage range of the insulation tester); do not use a faulty instrument. It is strictly forbidden to connect only a single main circuit terminal to the insulation test, otherwise there will be a risk of damage to the transformer. Do not perform insulation test on the control terminals, otherwise the inverter will be damaged. After the test is completed, remember to remove all the wires shorting the loop terminals.

(7) If the insulation test is performed on the motor, the wires between the motor and the inverter must be completely disconnected before testing the motor separately. Otherwise, there is a risk of damage to the inverter.

### 2) Regular maintenance

In order to make the inverter work normally for a long time, the service life of the electronic components inside the inverter must be regularly maintained. The use of the electronic components differs depending on the conditions. The maintenance period of the inverter as shown in the following table is for reference.

Item	Standard replacement years
Cooling fan	2~3 years
Electrolytic capacitor	4~5 years
Printed circuit board	5~8 years

China Technical Service Headquarter Manufacturer: Shanghai  
Sanyu Industry Co.,Ltd.  
Address: Room 723, No.800 Shangcheng Road, Shanghai, China  
Tel: +86-21-65046976  
Fax: +86-21-516865815  
Postal code: 200120  
Website: [www.sanyuacdrive.com](http://www.sanyuacdrive.com)  
E-mail: [infor@sanyuinverter.com](mailto:infor@sanyuinverter.com)