

INDUSTRIAL AUTOMATION

USER MANUAL

Manuale d'uso

Manuel d'emploi

Bedienungsanleitung

Manual de uso

Manual do usuário

Руководство по эксплуатации

VARIABLE FREQUENCY DRIVE **SINUS MINI** Basic User Manual-Manuale d'uso Basic

Foreword

Thank you for using the SINUS MINI series of high performance vector inverter.

SINUS MINI series inverter is a new generation of high performance vector control inverter developed by our company. The product has advanced control mode, and realizes high torque, high precision, high reliability and wide speed drive. The inverter built-in simple PLC, PID controller, programmable input and output terminals, RS485 interface, analog input / output control function and other rich control functions. It provides a high degree of integration solution for equipment support, engineering transformation, automation control and special industry application

This manual is random data ,It is only for safety considerations, installation and wiring, keyboard operation, table function, fault code construction , maintenance and other aspects of the presentation, For detailed functional notes, please refer to the SINUS MINI product brochure or consult our company. This manual is the basic instruction document for your proper use and display of its superior performance and safe operation. Please read it carefully and keep it properly, and please hand it to the end user of this product

In the process of using, If you have any problems or special requests, please contact our company (Office) or dealer ,You can also contact our customer service center directly, and we will be happy to serve you,

The company has been committed to the continuous optimization of the product, because this series of products and related information may be optimized or changed, there are possible changes, subject to change without notice.Please forgive me for the inconvenience caused.

Reader

This instruction manual is suitable for the following personnel to read:

Inverter installation personnel, engineering and technical personnel (electrical engineers, electrical operators, etc.), designers

Please ensure that this instruction manual reaches the end user.

General notes



Caution: Due to the dangers posed against the required operation, may lead to moderate harm or minor injuries, and damage to the equipment;



Warning: Due to the dangers posed against the required operation, may result in serious injury and even death;

Contents

CHAPTER 1 INTRODUCTION TO SINUS MINI SERIES INVERTER	5
1.1 PRODUCT MODEL DESCRIPTION.....	5
1.2 SAFETY PRECAUTIONS	6
1.3 PRODUCT SERIES	8
1.4 PRODUCT STANDARD SPECIFICATION	10
1.5 USE NOTE.....	11
CHAPTER 2 INVERTER INSTALLATION	13
2.1 INSTALLATION ENVIRONMENT	13
2.2 MECHANICAL INSTALLATION	14
2.3 INVERTER SHAPE AND INSTALLATION DIMENSIONS	15
2.4 THE SHAPE AND MOUNTING DIMENSIONS OF THE OPERATING PANEL (UNIT: MM)	16
2.5 KEYBOARD TRAY	16
CHAPTER 3 WIRING OF INVERTER.....	17
3.1 CONNECTION OF THE PRODUCT AND PERIPHERAL DEVICES.....	17
3.2 DESCRIPTION OF PERIPHERAL DEVICES FOR MAIN CIRCUIT	18
3.3 SELECTION OF MAIN CIRCUIT PERIPHERAL DEVICES.....	18
3.4 TERMINAL WIRING	19
3.5 CONTROL CIRCUIT TERMINAL FUNCTION.....	20
3.6 PERIPHERAL DEVICE SELECTION OF CONTROL CIRCUIT	21
3.7 FUNCTION OF MAIN CIRCUIT TERMINAL.....	21
3.8 ATTENTION FOR MAIN CIRCUIT WIRING.....	22
CHAPTER 4 KEYBOARD OPERATION	24
4.1 KEYBOARD INTRODUCE.....	24
4.2 DESCRIPTIONS OF INDICATORS.....	24
4.3 BUTTON DESCRIPTION OF KEYBOARD.....	25

4.4 KEYPAD OPERATING STATUS.....25

4.5 PANEL OPERATION METHOD26

4.6 PARAMETER DISPLAY.....27

4.7 MOTOR AUTO-TUNING PROCEDURE28

4.8 RUNNING FOR THE FIRST TIME.....29

CHAPTER 5 LIST OF PARAMETERS30

5.1 FUNCTION PARAMETER TABLE.....30

CHAPTER 6 DETAIL FUNCTION INTRODUCTION50

F0 BASIC FUNCTION PARAMETERS.....50

F1 AUXILIARY FUNCTION PARAMETERS 1.....56

F2 AUXILIARY FUNCTION PARAMETERS 2.....59

F3 MOTOR PARAMETERS65

F4 DEDICATD FUNCTION FOR V/F CONTROL.....66

F5 VECTOR CONTROL FUNTION68

F6 I/O OUTPUT TERMINAL71

F7 ANALOG INPUT TERMINAL FUNCTION83

F8 ANALOG OUTPUT TERMINAL85

F9 PROGRAM OPERATING PARAMETERS.....87

FA PID PARAMETER90

FB TRAVERSE FUNCTION92

FC COMMUNICATION AND BUS CONTROL FUNCTION94

FD FAULTS AND PROTECTION PARAMETERS.....95

FE FACTORY RESERVED98

FF FACTORY RESERVED.....98

FH DISPLAY FUNCTION.....99

CHAPTER 7 FAULT DIAGNOSIS AND TROUBLESHOOTING102

7.1 FAULT QUERY AT FAULT 102

7.2 LIST OF FAULT AND ALARM INFORMATION..... 103

7.3 TROUBLESHOOTING PROCEDURES 107

CHAPTER 8 ROUTINE REPAIR AND MAINTENANCE 108

8.1 ROUTINE MAINTENANCE 108

8.2 PERIODIC MAINTENANCE 109

8.3 COMPONENT REPLACEMENT 109

8.4 INSULATION TEST 110

APPENDIX A COMMUNICATION PROTOCOL 111

APPENDIX B CONTROL MODE SETTING PROCESS 124

WARRANTY AGREEMENT 125

Chapter 1 Introduction to SINUS MINI Series Inverter

1.1 Product Model Description

Before unpacking the product, please check product packaging for shipping damage caused by careless transportation and whether the specifications and type of the product complies with the order. If any questions, please contact the supplier of SINUS MINI series inverter, or directly contact the .

Model specification:

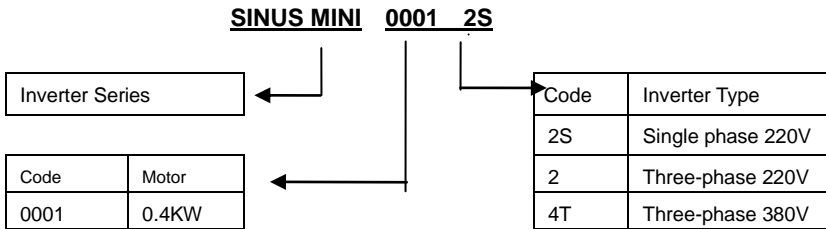
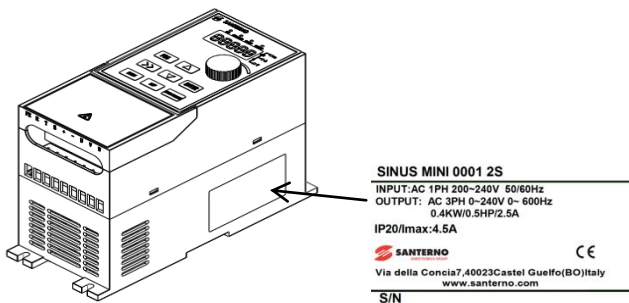

Fig. 1-1 Inverter symbol description

Below the right plate of the inverter case, a nameplate indicating the type and the rated value of the inverter is attached. The contents are as follows:



1.2 safety Precautions

Description of safety marks:



Danger: The misuse may cause fire, severe injury, even death.



Note: The misuse may cause medium or minor injury and equipment damage.

Procedure qualification

This product must be operated by trained professionals. Moreover, operations personnel must undergo professional training, familiar with equipment installation, wiring, operation and maintenance, and the correct response to the use of various emergency situations arise.

Safety guidance

A warning sign is put forward for your safety, is to prevent the operation of injuries, and take the product and related system damage measures; please read this manual carefully before use, and in strict accordance with the safety rules in this manual and warning signs for the operation.

- Proper transport, storage, installation, and careful operation and maintenance is very important for the safe operation of the inverter. During the transportation and storage to ensure the inverter from shock and vibration, but also must ensure that the store in a dry, non corrosive gas, no conductive dust and environmental temperature less than 60 degrees Celsius.
- This product with the dangerous voltage, and it is under the control of the movement mechanism with potential risk, if you do not comply with the provisions of this manual or not according to the operation requirements, may cause casualties, damage to the products and related systems.
- Do not make the connection work in power on state, otherwise the risk of death caused by electric shock; in wiring, inspection, maintenance and operation, disconnect all power related equipment, and confirm the main circuit of the DC voltage has dropped to a safe level, wait 5 minutes and then carry on the related work.
- The power line, the motor line and the control line must be fastened and connected. The grounding terminal must be reliably grounded and the grounding resistance is less than 10 Omega
- The static electricity of the human body will seriously damage the internal sensitive devices, and please comply with the measures and methods stipulated in the electrostatic prevention measures (ESD) before the relevant operations, otherwise the frequency inverter may be damaged
- Since the output voltage of the inverter is a pulse waveform, if the output side is equipped with capacitors to improve the power factor or lightning protection varistors, etc., be sure to remove or modify the input side of the inverter

- The output side of the inverter shall not switch devices such as circuit breakers and contactor (if the switching device must be switched on the output side, the output current of the inverter must be zero when the switch is switched on control)
- No matter where the fault occurs in the control equipment, it is possible to cause a shutdown and major accidents. Therefore, please take the necessary external protection measures or backup devices
- This product can only be used in accordance with the use of the manufacturer. Without permission, it shall not be used in special areas such as emergency response, rescue, ship, medical, aviation, nuclear facilities, etc.
- Only the maintenance of products by the company or the company's licensing professionals, unauthorized modification, the use of non recognition of the company's accessories, may lead to product failure. In the maintenance, any defective devices must be promptly replaced.

1.3 Product Series

SINUS MINI-□□□□2S Single phase AC220V constant torque / heavy load application

Power (kW)		0.4	0.75	1.5	2.2
Motor power (kW)		0.4	0.75	1.5	2.2/3.0
Output	Voltage (V)	Three-phase 0 to rated input voltage			
	Rated current (A)	2.6	4.5	7.5	12
	Overload capacity	150% 1 minute, 180% 2 seconds, 200% 0.5 seconds, 10 minutes (inverse time lag feature)			
Input	Rated voltage / frequency	Single phase 200V~240V; 50Hz/60Hz			
	Allowable voltage range	180V~260V; Voltage imbalance: ≤3% ; Allowable frequency fluctuation: ±5%			
	Rated current (A)	5.9	8.3	14.1	24.2
Brake unit		Built-in as standard			
Protection class		IP30			
Cooling mode		Self-cooling		Forced air convection cooling	

SINUS MINI-□□□□2T Three phase AC 220V constant torque / heavy load application

Power (kW)		0.4	0.75	1.5	2.2	4.0	/	/	/	/	/	/	/	/
Motor power (kW)		0.4	0.75	1.5	2.2	4.0	/	/	/	/	/	/	/	/
Output	Voltage (V)	Three-phase 0 to rated input voltage												
	Rated current (A)	2.6	4.5	7.5	10	17	/	/	/	/	/	/	/	/
	Overload capacity	150% 1 minute, 180% 2 seconds, 200% 0.5 seconds, 10 minutes (inverse time lag feature)												
Input	Rated voltage / frequency	3 phase 220V±15%; 50Hz/60Hz												
	Allowable voltage range	220V±15%; Voltage imbalance: ≤3% ; Allowable frequency fluctuation: ±5%												
	Rated current (A)	4.1	5.3	8.0	11.8	18.1	/	/	/	/	/	/	/	/
Brake unit		Built-in as standard						External braking unit needed						
Protection class		IP30												
Cooling mode		Self-cooling	Forced air convection cooling											

SINUS MINI-□□□□4T Three phase AC 380V constant torque / heavy load application

Power (kW)	0.75	1.5	2.2	4.0	5.5	/	/	/	/	/	/	/	/	/
Motor power (kW)	0.75	1.5	2.2	4.0	5.5	/	/	/	/	/	/	/	/	/
Out put	Voltage (V)	Three-phase 0 to rated input voltage												
	Rated current (A)	2.5	3.7	5.5	9	13	/	/	/	/	/	/	/	/
	Overload capacity	150% 1 minute, 180% 2 seconds, 200% 0.5 seconds, 10 minutes (inverse time lag feature)												
Inp ut	Rated voltage / frequency	3 phase 380V±15%; 50Hz/60Hz												
	Allowable voltage range	380V±15%; Voltage imbalance: ≤3% ; Allowable frequency fluctuation: ±5%												
	Rated current (A)	4.3	5.2	6.0	10.5	15.5	/	/	/	/	/	/	/	/
Brake unit	Built-in as standard								External braking unit needed					
Protection class	IP30													
Cooling mode	Self-cooling	Forced air convection cooling												

SINUS MINI-□□□□5T Three phase AC 460V constant torque / heavy load application

Power (kW)	0.75	1.5	2.2	4.0	5.5	/	/	/	/	/	/	/	/	/
Motor power (kW)	0.75	1.5	2.2	4.0	5.5	/	/	/	/	/	/	/	/	/
Out put	Voltage (V)	Three-phase 0 to rated input voltage												
	Rated current (A)	2.5	3.7	5.5	9	13	/	/	/	/	/	/	/	/
	Overload capacity	150% 1 minute, 180% 2 seconds, 200% 0.5 seconds, 10 minutes (inverse time lag feature)												
Input	Rated voltage / frequency	3 phase 460V±15%; 50Hz/60Hz												
	Allowable voltage range	460V±15%; Voltage imbalance: ≤3% ; Allowable frequency fluctuation: ±5%												
	Rated current (A)	4.1	4.9	5.7	9.4	12.5	/	/	/	/	/	/	/	/
Brake unit	Built-in as standard								External braking unit needed					
Protection class	IP30													
Cooling mode	Self-cooling	Forced air convection cooling												

1.4 Product standard specification

Item		Specifications
power	Voltage frequency	Single-phase 220V/50/60Hz, Three-phase 380V 50/60Hz
	Allowable fluctuation	voltage: $\pm 15\%$, frequency: $\pm 5\%$
Control performance	Frequency range	0-600Hz
	Output frequency	The maximum frequency value $\pm 0.1\%$
	Output frequency	Operate keyboard up and down keys: 0.01Hz Potentiometer analog input: 0.2Hz
	Run command given mode	The keyboard is given; the external terminal is given; the serial port is given by the host computer
	carrier frequency	2.0-12.0KHz
	Torque boost	0-20.0% adjustable, optional v/f curve optional
	overload capacity	150% rated output current 1 minute, 180% rated output current 2 second
	Acc/Dec time	0.1-3600 second
	Rated output voltage	Using the power supply voltage compensation function, the motor rated voltage is 100%, which can be set in the range of 50-100% (the output can not exceed the input voltage)
	AVR function	When the network voltage fluctuates, the output voltage fluctuation is very small and almost constant V/F
	standard feature	PID control, acceleration and deceleration time is adjustable, variable deceleration mode, carrier frequency, torque, current limiting, power off, restart, jump frequency control, lower frequency running, multi-speed, swing frequency, RS485, analog output, fault slip compensation, automatic reset
	braking	Energy consumption braking, DC braking
	Frequency setting input	Keyboard digital setting, external terminal AI1 (0-10V/0-20mA switchable), AI2 (0-10V/0-20mA switchable), RS485 and signal combination and terminal selection
	Signal feedback input	External terminal AI1 (0-10V/0-20mA switchable), AI2 (0-10V/0-20mA switchable), RS485
	Input instruction signal	Start, stop, reverse, inching, multi-speed, free parking, reset, acceleration and deceleration time selection, frequency setting, channel selection, external fault alarm, etc.
External output signal	Relay output, collector output, 0-10V output, 4-20mA output	
protective function	Over voltage, under voltage, over current, current limit, overload, overheating, electronic thermal overload relay, stall, data protection, etc.	

display	Four digit display (LED)	15 kinds of parameters, such as frequency setting, output frequency, output voltage, output current, motor speed, output torque, digital value terminals, program menu parameters and 33kinds of fault codes
	indicator lamp (LED)	Run/stop status, etc.
Operating environment	Environment	Inside, low than 1000m, free from dust, corrosive gas and direct sunlight
	Ambient temperature	-10℃~+40℃ (bare machine -10℃~+50℃) , 20%~90%RH (no condensing)
	Vibration	less than 0.5g
	Storage temperature	-25℃~+65℃
	Installation	Wall mounted or surface mounted inside a cabinet
Protection class		IP30
Cooling		Forced air cooling.

1.5 Use note

The design of the inverter allows it to operate in an industrial environment with electromagnetic interference. Usually, if the quality is good, it can ensure the safety of inverter and trouble free operation, please install to ensure the inverter can run reliably and effectively avoid the electromagnetic interference caused by the following rules.

- Ensure that the grounding cable of all control devices are connected to the inverter as transducer with short and thick, reliably connected to public places or public star connection grounding bus motor; please contact the nearest ground, please do not put the shell of the motor is connected to the earthing terminal or inverter control system protection.

- When the equipment is not grounded, the contact leakage occurs. Please connect the grounding end of the inverter to the equipment shell and motor shell, and the single phase 220V inverter N terminal must be connected to zero line

- Conductors are preferably flat and multi-core because they are less impedance at high frequencies

- The ends of the truncated cables should be as neat as possible to ensure that the segments are as short as possible

- Control cable wiring should be far away from the power supply cables and the motor cable, use wire slot alone, and must be in power cables and the motor cable when crossing each other should adopt 90 degrees vertical cross.

- The cabinet is installed to ensure the contactor with a surge suppressor. Or, there is a 'R-C' damping circuit is connected to the coil of AC contactor, the use of varistor and corresponding coil voltage; the coil DC contactor is connected with a "freewheeling diode" or coil device voltage corresponding to the type of

varistor; the output control relay in inverter contactor occasions and frequent action, this is especially important.

- The connection wire of the motor shall be shielded cable or armored cable, and the grounding end of the shielding layer can be reliably grounded by the cable grounding card



- Install "input noise filter" can reduce the electromagnetic interference brought from the grid side of other equipment, the input side noise filter "must be as close as possible to the inverter power input terminal, at the same time, with the same inverter filter must be reliable grounding.

- Install "the output side filter can reduce noise" wireless interference from the motor and the inductive interference, "the output side filter noise" must be as close as possible to the inverter output terminals, at the same time, with the same inverter filter must be reliable grounding.

- Shielded cable or twisted pair shall be used whenever the control loop is connected

- Adding the "zero phase reactor" in the power line near the inverter input terminal, adding the "zero phase reactor" in the motor line near the inverter output terminals, adding "zero phase reactor" in the control line near the inverter control terminal, can effectively reduce the electromagnetic interference and the main power cable connected inverter induction.

- Grounding, correct and reliable grounding are the basic conditions for the safe and reliable operation of this product. In order to properly connect the inverter to the ground, please read the following cautions carefully

<p>warning</p> 	<ul style="list-style-type: none"> ●To avoid electric shock, please use the dimensions specified in the electrical equipment technical standard, and shorten the wiring length as much as possible, and the grounding resistance is below 10 Omega. Otherwise, the leakage current caused by the inverter will lead to the unstable potential of the grounding terminal far from the grounding point, which will lead to an electric shock accident
<p>Caution</p> 	<ul style="list-style-type: none"> ●Do not share the ground wire with the welder or power equipment that requires high current / pulse current, otherwise it will cause abnormal operation of the inverter ●When using multiple inverters, do not loop the ground. Otherwise, the inverter will act abnormally ●The motor must be grounded independently, and the motor casing can not be connected to the ground terminal of the inverter, nor can the same ground network be shared with the control system

Chapter 2 Inverter Installation

To ensure the safe use of this product, to maximize the performance of the inverter and to ensure the reliable operation of the inverter, please strictly follow the environment, wiring, ventilation and other requirements described in this chapter

2.1 Installation environment

In order to give full play to the performance of this product and maintain its function for a long time, the installation environment is very important. Please install this product in the environment that meets the requirements shown in the following table

Environment	Requirement
Installation environment	Installation indoor without direct sunlight
Work temperature	-10 ~ +40°C
Storage Temperature	-20 ~ +60°C
Environment temperature	No condensation under 95%RH
Ambient environment	<p>Please install the inverter in the following places:</p> <ul style="list-style-type: none"> ●No oil fog, corrosive gas, flammable gas, dust and other places; ●Metal powder, oil, water and other foreign matter will not enter the frequency inverter inside the place (do not install the frequency inverter on wood and other flammable substances above); ●A place where radioactive substances are not flammable; ●A place where no noxious gas or liquid is found; ●A place where little salt is eaten; ●A place where there is no direct sunlight
Height above sea level	Below 1000m
Vibration	Below 10~ 20Hz: 9.8m/s ² ; Below 20~55Hz : 5.9m/s ²

<p>Installation and cooling</p>	<ul style="list-style-type: none"> •The inverter shall not be installed horizontally or horizontally, and vertical and vertical installation must be guaranteed; •High resistance heating equipment such as braking resistance, please install independently, avoid and inverter installed in the same cabinet, it is strictly prohibited to brake resistance and other high heating equipment installed in the inverter inlet
---------------------------------	--------------------------------------------------------------------------------------------------------------------------------------------------------------------------------------------------------------------------------------------------------------------------------------------------------------------------------------------------------------------------------------------------------------------------------------------------------

2.2 Mechanical installation

- SINUS MINI series inverter components

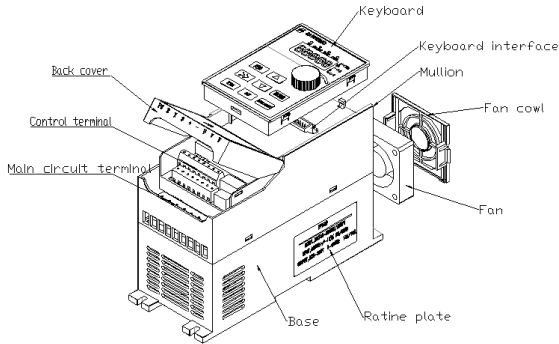

- Installation space, direction and space

Installation: single frequency governor to install in indoor ventilated place, and a wall hanging cabinet type or vertical installation. And with the adjacent items or baffle (wall) must keep enough space.

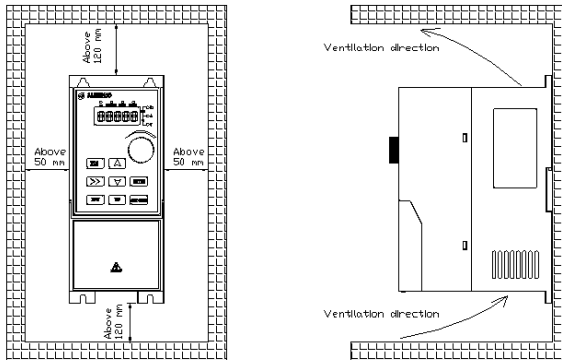

installation diagram of single inverter

Multiple installation: when installing multiple inverters in the control cabinet, please ensure the following installation space.

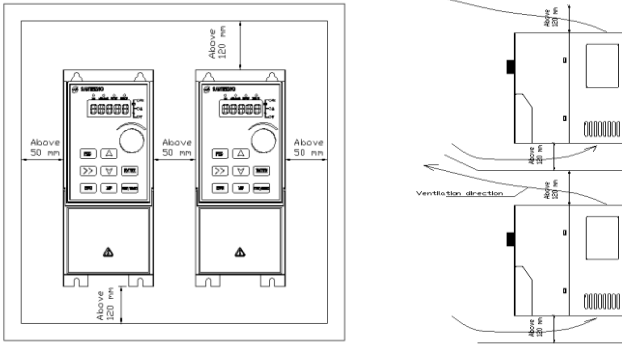

Installation diagram of multi inverters

2.3 Inverter shape and installation dimensions

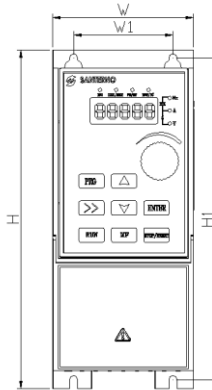

Voltage level	Inverter model	Outline construction and installation dimension (mm)						Weight (kg)
		W	H	D	W1	H1	Mounting hole d	
Single phase 220V	SINUS-0001 2S	78	188	126	55	178	4	1.5
	SINUS-0002 2S							
	SINUS-0003 2S							
	SINUS-0004 2S	96	225	137	65	215	4	
Three-phase 220V	SINUS-0001 2T	78	188	126	55	178	4	1.5
	SINUS-0002 2T							
	SINUS-0003 2T							
	SINUS-0004 2T	96	225	137	65	215	4	

Three -phase 380V	SINUS-0002 4T	78	188	126	55	178	4	1.5
	SINUS-0003 4T							
	SINUS-0004 4T							
	SINUS-0005 4T	96	225	137	65	215	4	2
	SINUS-0006 4T							
Three -phase 460V	SINUS-0002 5T	78	188	126	55	178	4	1.5
	SINUS-0003 5T							
	SINUS-0004 5T							
	SINUS-0005 5T	96	225	137	65	215	4	2
	SINUS-0006 5T							

2.4 The shape and mounting dimensions of the operating panel (unit: mm)

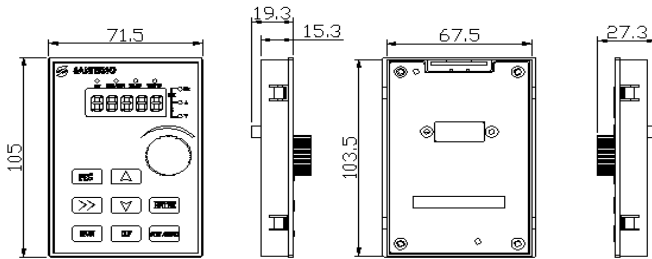

Keyboard (SINUS MINI-DF01)

Rear view of Keyboard

2.5 Keyboard tray

SINUS MINI-DF03 is the operation panel to install plate cabinet use, its shape and size are as follows:

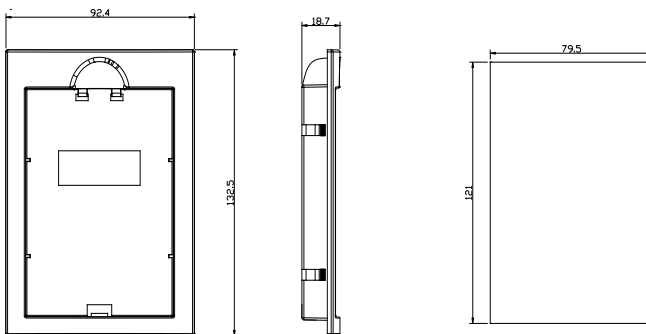

Chapter 3 Wiring of Inverter

3.1 Connection of the Product and peripheral Devices

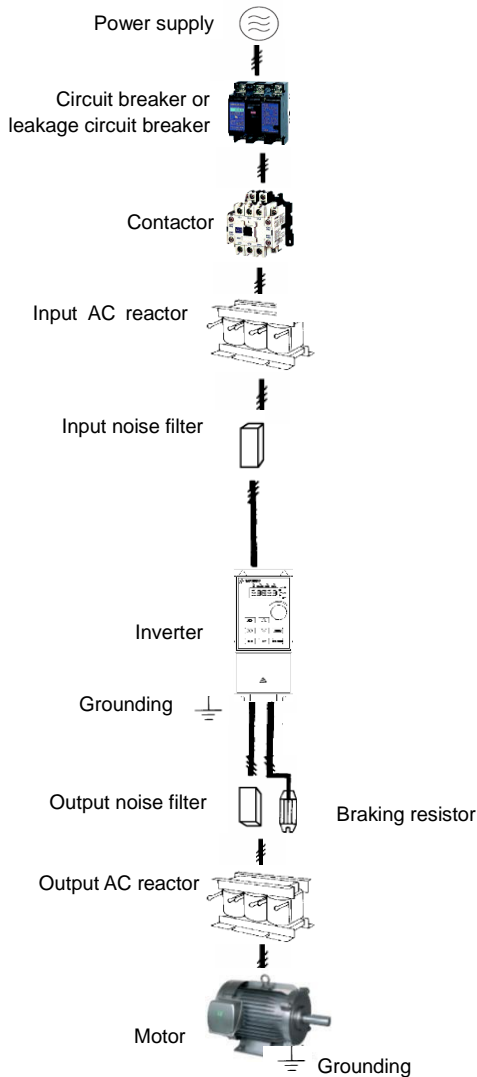

Fig.3-1 Connection diagram of the product and peripheral devices

3.2 Description of peripheral Devices for Main Circuit

Circuit breaker	The capacity of the circuit breaker shall be 1.5 ~ 2 time of the rated current of the inverter. The time features of the circuit breaker shall fully consider the time features of the inverter overload protection.
Leakage circuit breaker	Because the inverter output is the high-frequency pulse, there will be high-frequency leakage current. Special leakage circuit breaker shall be used when installing leakage circuit breaker at the input end of the inverter. It is suggested that B type leakage circuit breaker be used, and the leakage current value shall be set as 300mA.
Contactor	Frequent open and close of contactor will cause inverter failure, so the highest frequency for the open and close of contactor shall not exceed 10 times/min. When braking resistor is used, to void the over temperature damage of the braking resistor, thermal protection relay with braking resistor over temperature detection shall be installed to disconnect the contactor at the contact control power side of the thermal protection relay.
Input AC reactor	<ol style="list-style-type: none"> The inverter power supply capacity is more than 600kVA or 10 times of the inverter capacity. If there is switch type reactive-load compensation capacitor or load with silicon control at the same power node, there will be high peak current flowing into input power circuit, causing the damage of the rectifier components. When the voltage unbalanced of the three-phase power supply of the inverter exceeds 3%, the rectifier component will be damaged. It is required that the input power factor of the inverter shall be higher than 90%. When the above situations occur, install the AC reactor at the input end of the inverter.
Input noise filter	The noise input from the power end to the inverter and output from the inverter to the power end can be reduced.
Thermal protection relay	Although the inverter has motor overload protection function, when one inverter drives two or more motors or multi-pole motors, to prevent the motor over temperature failure, thermal protection relay shall be installed between the inverter and each motor, and the motor overload protection parameter FD.00 shall be set as "2" (motor protection disabled).
Output noise filter	When the output end of the inverter is connected with noise filter, the conduction and radiation interference can be reduced.
Output AC reactor	When the cable connecting the inverter and the motor is longer than 100m, it is suggested to install AC output reactor to suppress the high-frequency oscillation to avoid the damage to motor insulation, large leakage current and frequent inverter protective action.

3.3 Selection of Main Circuit peripheral Devices

Inverter model	Circuit Breaker (A)	Contactor (A)	E P B R S T U V W			Grounding terminal PE		
			Terminal screw	Tightening torque (N·m)	Wire specific ation (mm ²)	Terminal screw	Tightening torque (N·m)	Wire specific ation (mm ²)
SINUS-0001 2S	16	10	M4	1.2~1.5	2.5	M4	1.2~1.5	2.5
SINUS-0002 2S	25	16	M4	1.2~1.5	2.5	M4	1.2~1.5	2.5
SINUS-0003 2S	32	25	M4	1.2~1.5	4	M4	1.2~1.5	2.5
SINUS-0004 2S	40	32	M4	1.2~1.5	6	M4	1.2~1.5	4
SINUS-0002 4T	10	10	M4	1.2~1.5	2.5	M4	1.2~1.5	2.5
SINUS-0003 4T	16	10	M4	1.2~1.5	2.5	M4	1.2~1.5	2.5
SINUS-0004 4T	16	10	M4	1.2~1.5	2.5	M4	1.2~1.5	2.5
SINUS-0005 4T	25	16	M4	1.2~1.5	4	M4	1.2~1.5	4
SINUS-0006 4T	32	25	M4	1.2~1.5	6	M4	1.2~1.5	6

3.4 Terminal wiring

This section describes all the precautions and requirements that ensure the user's safe use of the product, maximize the performance of the inverter, and ensure the reliable operation of the inverter. The standard wiring diagram is as follows:

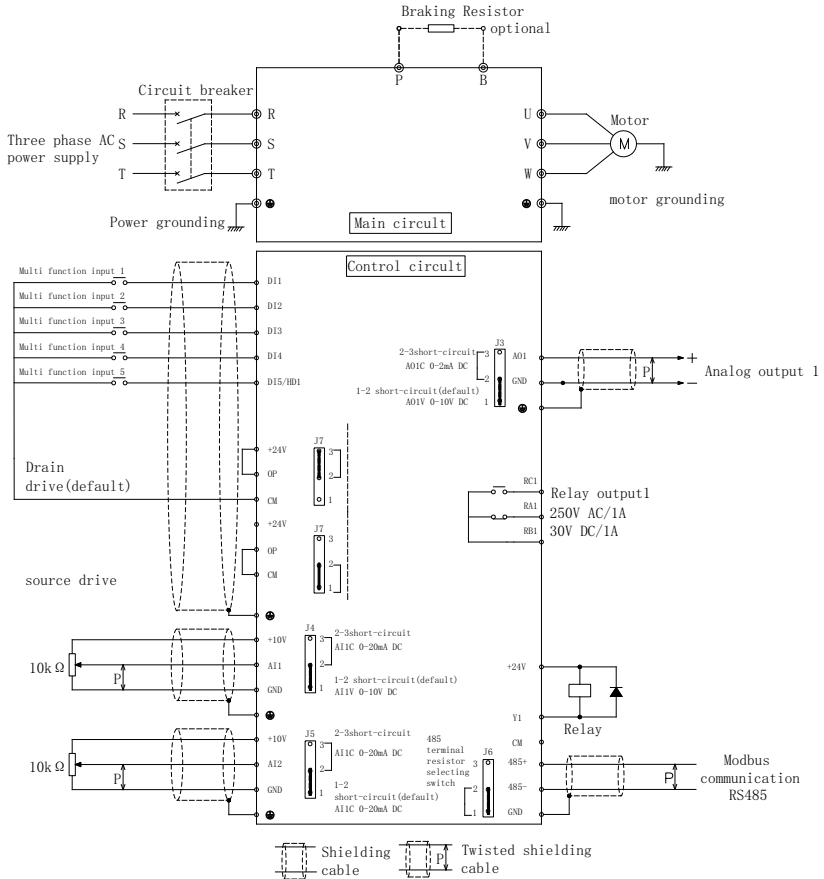

Note:

Analog output is frequency, current, voltmeter and other instructions for specific output, can not be used for feedback and other control operations

3.5 Control circuit terminal function

3.5.1 Control loop terminal line

+10V	A01	485+	485-	DI2	DI4	Y1	COM				
GND	A11	A12	DI1	DI3	DI5	+24V	COM	RA1	RB1	RC1	

3.5.2 Control circuit terminal instruction

Type	Terminal sign	Terminal Name	Function Description
Power supply	+10V-GND	External terminal of 10V power supply	Provide +10V power supply for external units, with maximum output current of 10mA. It is generally used as the operating power supply for the external potentiometer. The potentiometer resistance range is 1kΩ to 5kΩ.
	+24V-COM	External terminal of 24V power supply	Provide +24V power supply for external units. It is generally used as the operating power supply for digital input/output terminal and the external sensor. Maximum output current: 200mA
	OP	External power input terminals	When using external signal to drive DI1~DI5,OP should be connected to external power supply,The factory defaults (J7) to the 24V connection
Analog input	A11-GND	Analog input terminal 1	1. Input voltage range: DC 0V ~ 10V /4mA ~ 20mA, chosen by jumper J4 on control board. 2. Input impedance: 22kΩ of voltage input, 500Ω of current input.
	A12-GND	Analog input terminal 2	1.Input range: DC 0V~10V/4mA~20mA, chosen by jumper J5 on control board 2.Input impedance: 22kΩ of voltage input, 500Ω of current input.
Digital Input	DI1-OP	Digital Input 1	1. Optical coupling isolation, bipolar input. 2. Input impedance: 4.7kΩ. 3. Electrical level input range: 9V~30V.
	DI2-OP	Digital Input 2	
	DI3-OP	Digital Input 3	
	DI4-OP	Digital Input 4	Input impedance: 2.4 kΩ.
	HDI DI5-OP	High-speed pulse input terminal (Optional)	DI5 can be used as high-speed pulse input channel. Maximum input frequency: 100kHz.
Analog output	A01-GND	Analog output 1	The voltage or current output is determined by jumper J3 on the control panel. Output voltage range: 0V to 10V Output current range: 0mA to 20mA.

Digital Output	Y1-COM	Digital output 1 (High-speed pulse output) (Optional)	Optical coupling isolation,dual polarity open collector output. Output voltage range: 0V to 24V Output current range: 0mA to 50mA
Relay output1	RB1-RA1	Normally closed	Contact driving capacity: AC250V, 3A, COS ϕ =0.4
	RB1-RC1	Normally open	
terminal 485	485+	485Positive signal of differential signal	Rate: 1200/2400/4800/9600/19200/38400 Up to 32 units at most, more than 32 units, use repeaters.The longest distance 500m (shielded twisted pair cable using standard) J6: 485Terminal resistance selection: ON is a 100 Omega terminal resistor, OFF is no terminal resistance
	485-	485Negative side of differential signal	
	GND	485Shielding GND of communication	Internal isolation from COM

NOTE:

* If the user adjustable potentiometer in + 10V and GND, potentiometer resistance should not be less than 5K Omega

3.6 Peripheral device selection of control circuit

Terminal number	Terminal screw	tightening torque (N·m)	AWG mm ²	Types of wires
+10V、AO1、485+、485-、DI2、DI4、Y1、COM	M3	0.5~0.6	0.75	Double glue shielded cable
GND、AI1、AI2、DI1、DI3、DI5、+24V、COM	M3	0.5~0.6	0.75	shielded cable

3.7 Function of main circuit terminal

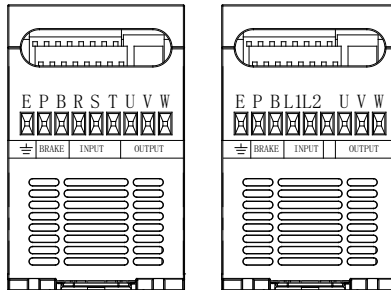

SINUS MINI-00xx 4T SINUS-00xx 2S

Terminal symbol	Terminal name and function description
R、S、T (L1、L2)	Three (single) phase current input terminals
P、B	Braking resistor connecting terminal
U、V、W	Three phase AC output terminal
E	Ground terminal PE

3.8 Attention for Main Circuit Wiring

3.8.1 Power Supply Wiring

- ◆ It is forbidden to connect the power cable to the inverter output terminal, otherwise, the internal components of the inverter will be damaged.
- ◆ To facilitate the input side over current protection and power failure maintenance, the inverter shall connect to the power supply through the circuit breaker or leakage circuit breaker and contactor.
- ◆ Please confirm that the power supply phases, rated voltage are consistent with that of the nameplate, otherwise, the inverter may be damaged.

3.8.2 Motor Wiring

- ◆ It is forbidden to short circuit or ground the inverter output terminal, otherwise the internal components of the inverter will be damaged.
- ◆ Avoid short circuit the output cable and the inverter enclosure, otherwise there exists the danger of electric shock.
- ◆ It is forbidden to connect the output terminal of the inverter to the capacitor or LC/RC noise filter with phase lead, otherwise, the internal components of the inverter may be damaged.
- ◆ When contactor is installed between the inverter and the motor, it is forbidden to switch on/off the contactor during the running of the inverter, otherwise, there will be large current flowing into the inverter, triggering the inverter protection action.
- ◆ If the cable between the inverter and the motor is too long, the higher harmonic leakage current of the output end will cause adverse impact on the inverter and the peripheral devices. It is suggested that when the motor cable is longer than 100m, output AC reactor be installed. refer to the following table for the carrier frequency setting.

Length of cable between the inverter and motor	Less than 50m	Less than 100 m	More than 100m
Carrier frequency (F2.30)	Less than 15kHz	Less than 10kHz	Less than 5kHz

3.8.3 Grounding Wiring

- ◆ The inverter will produce leakage current. The higher the carrier frequency is, the larger the leakage current will be. The leakage current of the inverter system is more than 3.5mA, and the specific value of the leakage current is determined by the use conditions. To ensure the safety, the inverter and the motor must be grounded.
- ◆ The grounding resistance shall be less than 10ohm. For the grounding wire diameter requirement, refer to 3.3 lectotype of main circuit peripheral devices.
- ◆ Do not share grounding wire with the welding machine and other power equipment.
- ◆ In the applications with more than 2 inverters, keep the grounding wire from forming a loop.



Correct

Wrong

Fig. 3-3 Grounding wiring

3.8.4 Countermeasures for Conduction and Radiation interference

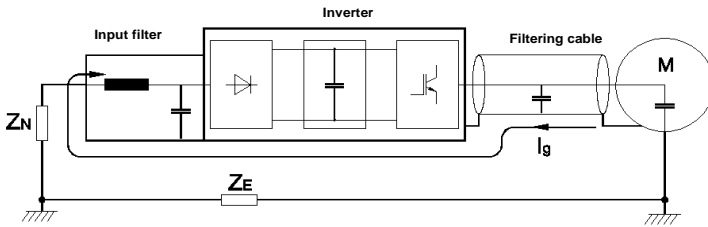

Fig.3-4 Noise current illustration

Fig. 3-4 noise current legend

- ◆ When the input noise filter is installed, the wire connecting the filter to the inverter input power end shall be as short as possible.
- ◆ The filter enclosure and mounting cabinet shall be reliably connected in large area to reduce the back flow impedance of the noise current I_g .
- ◆ The wire connecting the inverter and the motor shall be as short as possible. The motor cable adopts 4-core cable, with the grounding end grounded at the inverter side, the other end connected to the motor enclosure. The motor cable shall be sleeved into the metal tube.
- ◆ The input power wire and output motor wire shall be kept away from each other as long as possible.
- ◆ The equipment and signal cables vulnerable to influence shall be kept far away from the inverter.
- ◆ Key signal cables shall adopt shielding cable. It is suggested that the shielding layer shall be grounded with 360-degree grounding method and sleeved into the metal tube. The signal cable shall be kept far away from the inverter input wire and output motor wire. If the signal cable must cross the input wire and output motor wire, they shall be kept orthogonal.
- ◆ When analog voltage and current signals are adopted for remote frequency setting, twinning shielding cable shall be used. The shielding layer shall be connected to the grounding terminal PE of the inverter, and the signal cable shall be no longer than 50m.
- ◆ The wires of the control circuit terminals RA/RB/RC and other control circuit terminals shall be separately routed.
- ◆ It is forbidden to short circuit the shielding layer and other signal cables or equipment.
- ◆ When the inverter is connected to the inductive load equipment (e.g. electromagnetic contactor, relay and solenoid valve), surge suppressor must be installed on the load equipment coil, as shown in Fig.3-5.

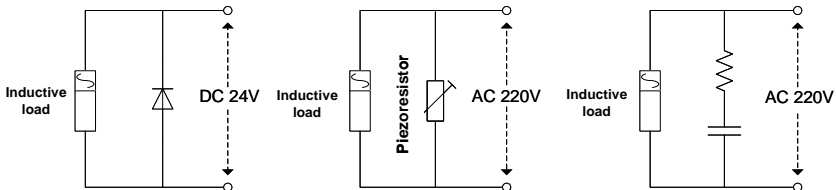

Fig.3-5 Application of inductive load surge suppressor

Chapter 4 Keyboard Operation

4.1 Keyboard introduce

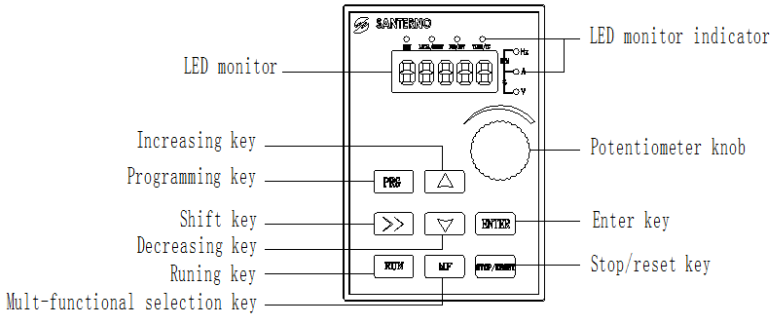

Figure 3 - 1 Keyboard (SINUS MINI-DF01)

4.2 Descriptions of Indicators

Indicator sign	name		Meanings
Indicator sign	name	Meanings	Color
LOCAL/REMO T	Running command reference mode indicator	OFF Running command is given by keyboard ON: Running command is given by terminal operation Flashing: Running command is given by host computer	red
RUN	Running status indicator	ON: running state OFF: stop state Flashing: stopping state	green
FWD/REV	Positive and negative indicator light	ON: forward running OFF : reverse running	red
TUNE/TC	Tuning/Fault indicator	ON: Fault condition OFF: Normal condition	red
Hz	Frequency indicator	ON Current display parameter is running frequency	red
A	Current indicator	ON: Current display parameter is current	red
V	Voltage indicator	ON: Current display parameter is voltage	red
RPM (Hz+A)	Rotating speed	ON: Current display parameter is rotating speed	red
S/M (A+V)	Time indicator	ON: Current display parameter is time	red
% (Hz+V)	% indicator	ON :Current display parameter is percentage	red

4.3 Button description of Keyboard

Sign	Name	Function
PRG	Programming key PRG	1. Switch between program and other states, which includes parameters display and programming; 2. In menu status, press this key to return previous menu.
OK	Enter OK	1. In program status, press this key to enter next menu. 2. In menu level 3, press this key to save parameters value.
▲	Increase ▲	1. In first level menu, increase function code PX according to edit bit 2. In second level menu, increase the function code PX YZ data. 3. In third level menu ,Increase the function code data
▼	Decrease ▼	1. In first level menu, decrease function code PX according to edit bit 2. In second level menu, decrease the function PX YZ code data 3. In third level menu ,decrease the function code data
>>	Shift >>	1. In third level menu , use key >> to shift edit bit of the data 2. In stop/run status, switch the panel display parameters such as frequency, current and voltage.
RUN	Run Key RUN	1. When running command is given via operation panel, the key is used to control the start of inverter. 2. After setting the parameter auto tuning, start parameter auto tuning for inverter start-up
STOP /RESET	Stop/Reset Key STOP/RESET	1. When running command is given via operation panel, the key is used to control the stop of inverter. 2. When the inverter has fault and has stopped, this key is used as RESET key to clear the fault alarm.
MF	Multi-function MF	0: Non function; 1: forward point running.;2: reverse

4.4 Keypad Operating Status

4.4.1 Initialization after power on

When the power is switched on, panel will start 5 seconds' initiation process. During this process, LED displays "8.8.8.8.", and all LED indicators on the panel are in ON stat

4.4.2 Stopping State

In stopping state, LED displays default parameters in flashing mode, and the unit indicator in right side displays the unit of this parameters. In this state, all status indicators are OFF, press ►► key ,LED displays fault code"n-xx"(xx=00-08), press SET key to enter and view the parameter; press PRG key to exit; and press ►► key to scroll through parameters in stopping state.

4.4.3 Running state

In stopping state, after receiving running command, the drive enters running state. The LED and unit

indicator display parameter and its unit respectively.

At this time, running status indicator is ON all the time. Press PRG key to enter programming menu and view parameter value.

Press ►► key, LED displays running parameter “r-xx” (xx=00~14). Press SET key to enter and view parameter value; press PRG key to exit this parameter menu; press ►► key to scroll through monitoring parameters.

4.4.4 Fault alarm state

In stopping, running or programming state, correspondent fault information will be reported if fault is detected. At this time, LED displays the fault code in flashing mode. When fault alarm occurs, press PRG key to enter programming menu and look up the fault log.

When fault alarm occurs, the alarm picture is displayed, and the fault can be reset by press STOP/RESET key. The drive restores to normal operation upon clearing the fault, and the fault code is displayed again if the fault has not been cleared.

4.5 Panel Operation Method

4.5.1 Panel Operation Procedure

parameter setting method via panel: through three-level menu, users can look up and modify the function codes very easily.

Three level menu structure: function parameters (first level)→function codes(second level)→value of function code(third level). Operation process is shown in Fig.4-1.

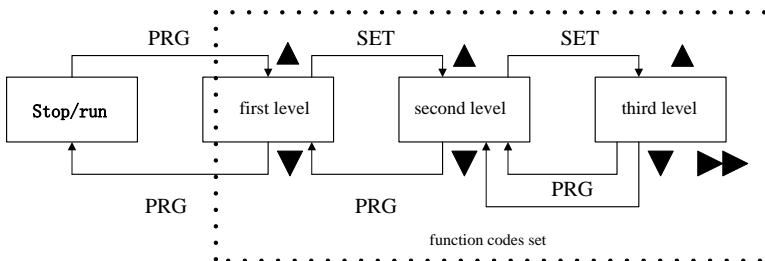

Fig.4-1 Menu Operation Procedure

In the third level menu, user can return second level menu by pressing PRG key or SET key. The different is: parameter settings can be saved in control board if SET key is pressed, then LED returns to second level menu and shifts to next function code automatically; If user presses PRG key, LED returns to second level menu directly, but the parameters can not be saved and stop at current function code.

4.5.2 parameter setup

Setting parameters correctly is a premise for actualizing SINUS MINI's performances. parameter setting method via panel will be introduced in the following part with rated power as an example (Change 18.5kW into 7.5kW).

Operation process is shown in Fig.4-2. Press the SHIFT key with single direction shifting function to shift the flashing bit of parameters (that is modification bit). After finishing the parameters setup, press the MENU key twice to exit programming state.

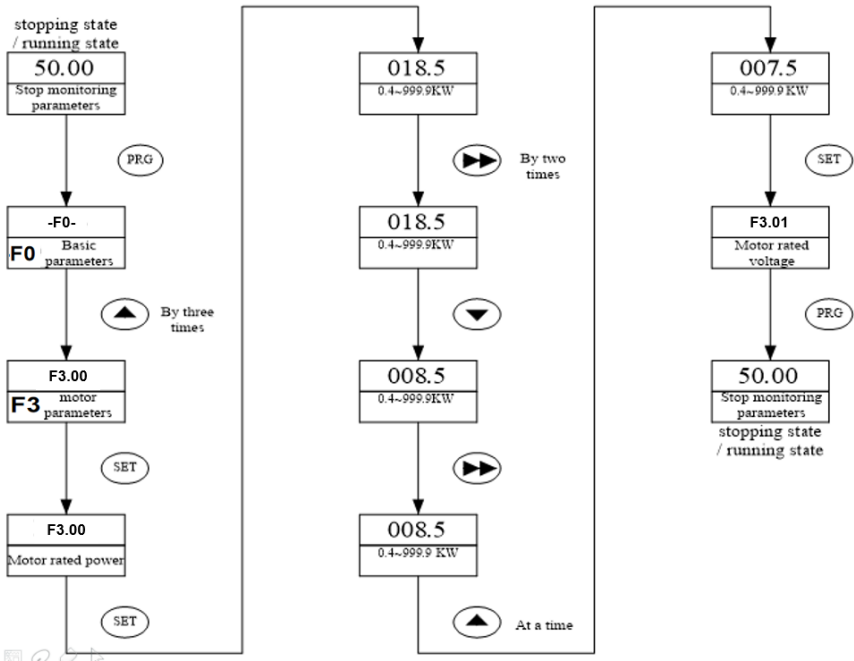

Fig 4-2 Procedure of parameter setup

4.6 parameter Display

In stopping state or running state, various state parameters can be displayed by LED. The displayed parameters can be decided by FH.00 ~ FH.01 and can be scrolled through by pressing the SHIFT key. The following is an explanation for the parameters operation method in stopping and running state.

4.6.1 Switch of parameter Display in Stopping State

In stopping state, the drive has 9 state parameters which can be scrolled by ►► key, they are: frequency setting, external counting value, digital value input terminal state, digital value output terminal state, panel potentiometer, analog input AI1, analog input AI2 and DC bus voltage. Please refer to the explanation of FH.01.

The default value of FH.01 is "preset frequency". If FH.01 value is set to 2, default display parameter in stopping state will be changed into "DC bus voltage".

User can look up other parameters during stopping state by pressing ►► key: Every time you press ►► key, the next parameter in stopping state will be displayed.

4.6.2 Switch of the running parameters

In running state, maximum 15 running state parameters can be displayed by SINUS MINI drive via ►► key.

4.7 Motor auto-tuning procedure

Before selecting vector control mode, user should input motor parameters correctly. SINUS MINI drive can get motor's standard parameters according to the parameters on nameplate; In order to get better control performance, you can control the drive to perform auto-tuning on the motor, so as to get accurate motor parameters. Tuning is divided into static tuning and overall auto-tuning. If the motor and load cannot be completely removed, F3.05 =1 shall be set for static tuning. The steps of tuning are as follows:

1. Set F0.01= 0 to select panel running command control mode;
2. According the motor's name-plate, Set F3.00、 F3.01、 F3.02、 F3.03、 F3.04 parameter in proper order.
3. Set F3.05=1, Select static auto-tuning, Or set F3.05 = 2, Select overall auto-tuning, Press "SET" key.
4. Press "run" and the keyboard displays "- id-" and starts tuning for 1-2 minutes.
5. After the tuning is finished, the machine is automatically stopped and the motor parameters are automatically saved.

4.8 Running for the First Time

Please follow the procedures to run the inverter for the first time:

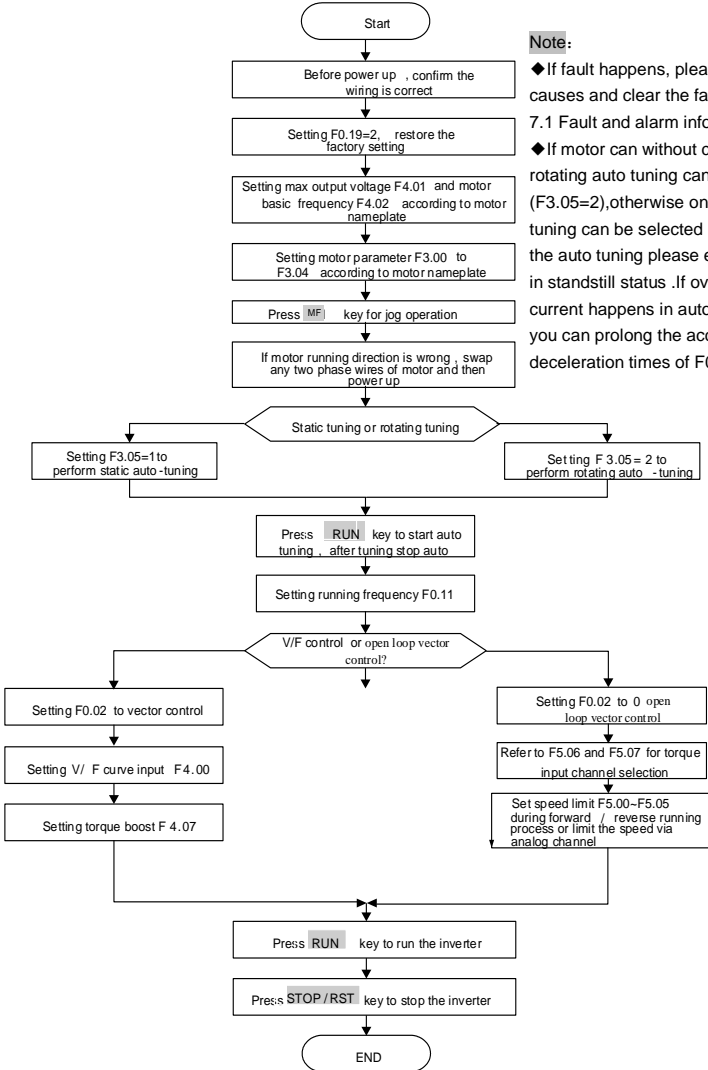

Note:

- ◆ If fault happens, please judge the fault causes and clear the fault according to 7.1 Fault and alarm information list.
- ◆ If motor can without connecting the load rotating auto tuning can be selected (F3.05=2), otherwise only static auto tuning can be selected. When enabling the auto tuning please ensure the motor is in standstill status. If over voltage or over current happens in auto tuning process, you can prolong the acceleration and deceleration times of F0.16 and F0.17.

Chapter 5 List of Parameters

Meanings of Each Item in Function Code parameter Table

Item	Meanings
Function code number	The number of function code, such as F0.00
Function code name	he name of function code, which explains the function code's meanings.
Function code selection	Function code parameter setting list
default value	Restore the settings of the function code after the product is delivered (see F0.19).
Order number	The order number of function code
Property	#: This function code can be changed during operation; +: This function code can only be changed during stopping status; *: The setting of this function code is read-only and cannot be changed.

5.1 Function parameter Table

Function code	Name	Description	Default	Property
F0.00	reserved			*
F0.01	Running command selection	0: keyboard operation 1: External terminal 2: Communication	0	+
F0.02	Control mode	0: open loop vector control 1: V/F control	1	+
F0.03	Main Frequency Source	0: Digital set via the keyboard 1: Keyboard potentiometer 2: External analog signal AI1(0~10V) 3: External analog signal AI2(0~20mA) 4: up/down1 setting 5: up/down2 setting 6: Multistage speed 7: PID 8: Serial communication setting 9: Program run	0	+

F0.04	Main frequency setting gain K1	0.000-9.999	1.000	+
F0.05	Zero frequency source of multi-speed mode	0: Reserved 1: Digital frequency of F0.11 2: External analog signal:AI1 3: External analog signal:AI2 4: Communication given	0	+
F0.06	Auxiliary frequency setting option	0: External analog signal AI1(0~10V) 1: External analog signal AI2(0~20mA) 2: External analog signal AI1(0~10V) (+/- polarity) 3: External analog signal AI2(0~20mA) (+/- polarity) 4: PID 5: Keyboard Increase and decrease key	0	+
F0.07	Auxiliary frequency range selection	0: Relative maximum frequency 1: Relative primary given	0	+
F0.08	Auxiliary frequency setting range	0-100%	100	+
F0.09	Setting Frequency selection	0: Main frequency 1: Auxiliary frequency 2: Main frequency + Auxiliary frequency 3: Main frequency - Auxiliary frequency 4: switch between Main frequency and Auxiliary frequency 5: switch between Main frequency and (Main frequency + Auxiliary frequency) 6: switch between Main frequency and (Main frequency - Auxiliary frequency) 7: MAX (Main frequency, Auxiliary frequency) 8: MIN (Main frequency, Auxiliary frequency) 9: Traverse operation	0	+
F0.10	UP/DOWN setting store selection	0: Store 1: Not Store	0	#
F0.11	Digital frequency setting	0~600.0Hz	50.00	#

F0.12	Rotating direction (Keypad operation)	0: FWD 1: REV	0	+
F0.13	Maximum output frequency	50.00~600.0 Hz	50.00	+
F0.14	High frequency limit	0.00 Hz ~ Maximum output frequency	50.00	+
F0.15	Low frequency limit	0.00Hz~ High frequency limit	0	+
F0.16	Acc time 1	0.1~3600.0s	20.0	#
F0.17	Dec time 1	0.1~3600.0s	20.0	#
F0.18	reserved		0	+
F0.19	parameter initialization	0: No operation 1: Clear fault information 2: Recover factory settings without motor parameters 3: Recover factory settings include motor parameters 4. Lock parameters Note: After executing 1~2 steps, restores to zero automatically.	0	+
F1.00	Starting mode	0: Start from starting frequency 1: After DC braking, start by starting frequency	0	+
F1.01	Starting frequency	0.50~20.00Hz	0.50	+
F1.02	Hold time of Starting Frequency	0.0~60.0s	0	+
F1.03	DC injection braking time at start	0.0~60.0s	0	+
F1.04	DC injection braking current start	0.0~100.0%(motor rated current)	0	+

F1.05	Stopping mode	0: Dec-to-stop 1: Dec-to-stop + DC braking 2: Free run to stop	0	+
F1.06	Initial frequency of DC injection brake	0.00~20.00Hz	0	+
F1.07	DC injection braking time	0: No operation 0.1~60.0s	0	+
F1.08	DC injection braking current	0.0~100.0%(motor rated current)	0	+
F1.09	Acc/Dec mode selection	0: Linear mode 1: Reserved	0	+
F1.10	Reserved	Reserved	0	+
F1.11	Reserved	Reserved	0	+
F1.12	Restart after power failure	0: disabled 1: enabled	0	+
F1.13	Delay time for restarting after power failure	0.0~20.0s	2.0	+
F1.14	dynamic braking start voltage	630-710	660	
F1.15	Rate of dynamic braking	0: No dynamic braking 1~100%	90	#
F1.16	Action on frequency lower than lower frequency limit	0: dormancy 1: start, running at lower frequency limit 2: Stop	0	+
F1.17	MF key function	0: No operation; 1: reverse rotation	0	+
F1.18	Stop/reset Key function	0: action on Keypad control mode 1: action on both Keypad and External terminal 2: action on both Keypad and communication	0	+

F1.19	Fan control function	0: always run after power on 1: stop fan after inverter stop running	1	+
F2.00	Acc time 2	0.1~3600s	20.0	#
F2.01	Dec time 2	0.1~3600s	20.0	#
F2.02	Acc time 3	0.1~3600s	20.0	#
F2.03	Dec time 3	0.1~3600s	20.0	#
F2.04	Acc time 4	0.1~3600s	20.0	#
F2.05	Dec time 4	0.1~3600s	20.0	#
F2.06	Jog Acc time	0.1~20.0s	10.0	#
F2.07	Jog Dec time	0.1~20.0s	10.0	#
F2.08	Jog frequency	0.50~60.00Hz	5.00	#
F2.09	Multi-frequency 1	0.00~600.0 Hz	0.00	#
F2.10	Multi-frequency 2	0.00~600.0 Hz	0.00	#
F2.11	Multi-frequency 3	0.00~600.0 Hz	0.00	#
F2.12	Multi-frequency 4	0.00~600.0 Hz	0.00	#
F2.13	Multi-frequency 5	0.00~600.0 Hz	0.00	#
F2.14	Multi-frequency 6	0.00~600.0 Hz	0.00	#
F2.15	Multi-frequency 7	0.00~600.0 Hz	0.00	#
F2.16	Multi-frequency 8	0.00~600.0 Hz	0.00	#
F2.17	Multi-frequency 9	0.00~600.0 Hz	0.00	#
F2.18	Multi-frequency 10	0.00~600.0 Hz	0.00	#
F2.19	Multi-frequency 11	0.00~600.0 Hz	0.00	#
F2.20	Multi-frequency 12	0.00~600.0 Hz	0.00	#
F2.21	Multi-frequency 13	0.00~600.0 Hz	0.00	#
F2.22	Multi-frequency 14	0.00~600.0 Hz	0.00	#
F2.23	Multi-frequency 15	0.00~600.0 Hz	0.00	#
F2.24	Jump frequency 1	0.00~600.0 Hz	0.00	+
F2.25	Jump frequency 2	0.00~600.0 Hz	0.00	+
F2.26	Jump frequency 3	0.00~600.0 Hz	0.00	+

F2.27	Jump frequency range	0.00~20.00 Hz	0.00	+
F2.28	FWD/REV dead time	0.1~3600s	0.5	+
F2.29	REV prohibited	0: REV enabled 1: REV disabled	0	+
F2.30	Carrier frequency	2.0~12.0KHz	3.0	+
F2.31	Zero frequency threshold	0.0~600.0Hz	0.00	+
F2.32	Zero frequency hysteresis	0.0~600.0 Hz	0.00	+
F2.33	Droop control	0.00-10.00Hz	0.00	+
F3.00	Motor rated power	0.4~999.9KW	Drive's rated power	+
F3.01	Motor rated voltage	0~440V	380V	+
F3.02	Motor rated current	0.1~999.9A	Drive's rated power	+
F3.03	Motor rated frequency	1.00~400.0Hz	50.00	+
F3.04	Motor rated speed	1~9999RPM	1440	+
F3.05	Motor auto-tuning	0: No operation 1: static auto tuning 2: overall auto- tuning	0	+
F3.06	Stator resistance	0.001-20.00%	Motor parameter	+
F3.07	Rotor resistance	0.001-20.00%	Motor parameter	+

F3.08	Self inductance	1.000-9.999	Motor parameter	+
F3.09	Leakage inductance	0.001-1.000	Motor parameter	+
F3.10	Exciting current with no load	0.0~999.9A	Motor parameter	+
F3.11	Reserved			+
F4.00	V/F control mode	0: Linear V/F 1: Square V/F 2: 1.5 times torque 3: 1.2 times torque 4: User defined V/F	0	+
F4.01	Base voltage	0~440V	380	+
F4.02	Base frequency	10.00~600.0 Hz	50.00	+
F4.03	Intermediate voltage 1	0~F4.04	32	+
F4.04	Intermediate voltage 2	F4.03~100%	50	+
F4.05	Intermediate frequency 1	0~F4.06	16.00	+
F4.06	Intermediate frequency 2	F4.05~400.0Hz	25.00	+
F4.07	Torque boost	0.0~20.0% (base voltage)	3.0	+
F4.08	Slip compensation	0.0~10.0%(rated speed)	0.00	+
F4.09	AVR function	0: disabled 1: enabled	0	+
F5.00	ASR proportional gain 1	0.000~6.000	2.000	+
F5.01	ASR integration time 1	0.000~9.999	0.500	+

F5.02	ASR proportional gain 2	0.000~6.000	1.000	+
F5.03	ASR integration time 2	0.000~9.999	1.000	+
F5.04	ASR switching frequency	00.00~99.99Hz	5.00	+
F5.05	Slip compensation gain	50.0~200.0%	100.0	+
F5.06	Driving torque limit	0~200.0%(motor rated current)	150.0	+
F5.07	Braking torque limit	0~200.0%(motor rated current)	150.0	+
F5.08	Reserved	Reserved		+
F5.09	Reserved	Reserved		+
F5.10	Reserved	Reserved		+
F6.00	FWD/REV mode	0: Two-line operation mode 1 1: Two-line operation mode 2 2: 3-line operation mode 1 3: 3-line operation mode 2	0	+
F6.01	Up/down rate	0.10~99.99Hz/s	1.00	#
F6.02	Definition of input terminal X1	0: No function 1: FWD	1	+
F6.03	Definition of input terminal X2	2: REV 3: External reset	2	+
F6.04	Definition of input terminal X3	4: Jog FWD 5: Jog REV	3	+
F6.05	Definition of input terminal X4	6: Multi-frequency 1 7: Multi-frequency 2	4	+
F6.06	Definition of input terminal X5	8: Multi-frequency 3 9: Multi-frequency 4 10: Terminals for selecting Acc/Dec time 1 11: Terminals for selecting Acc/Dec time 2	5	+

		<p>12: Normally open terminal for inputting external fault</p> <p>13: Normally close terminal for inputting external fault</p> <p>14: Frequency increase command</p> <p>15: Frequency decrease command</p> <p>16: Free run to stop</p> <p>17: Three-wire control</p> <p>18: switch of speed given mode</p> <p>19: Reset terminal for program operation</p> <p>20: Start traverse operation</p> <p>21: Pause traverse operation</p> <p>22: DC braking command</p> <p>23: Acc/Dec disabled command</p> <p>24: switch between panel control mode and external terminal control mode</p> <p>25: switch between panel control mode and communication control mode</p> <p>26: Counter trig signal</p> <p>27: Counter reset signal</p> <p>28: PID dormancy waking up</p> <p>29: switch between PID positive mode and negative mode</p> <p>30: emergence stop</p>		
F6.07	Terminal filter times	1-100	10	
F6.08	Operation protection of power on terminal	<p>0: protect</p> <p>1: no protect</p>	0	

F6.09	Programmable relay 1	0: No function 1: Drive ready	17	+
F6.10	Output terminal Y1 definition	2: Drive running signal 1 3: Drive running signal 2 4: Frequency arriving signal 5: Frequency detection threshold 1 6: Frequency detection threshold 2 7: High limit frequency arriving 8: Low limit frequency arriving 9: Overload signal 10: Over voltage stall 11: Over current stall 12: External stopping command 13: Preset counting value arriving 14: Specified counting value arriving 15: Low voltage lockup signal 16: Overload pre-alarm 17: Drive failure signal 18: Zero speed running 19: End signal of stage of program operation 20: End signal of cycle of program operation	1	+
F6.11	Frequency arriving width	0.00~10.00Hz	0.00	#
F6.12	FDT1 level	0.00~600.0 Hz	50.00	#
F6.13	FDT1 lag	0.00~10.00Hz	0.00	#
F6.14	FDT2 level	0.00~600.0 Hz	25.00	#
F6.15	FDT2 lag	0.00~10.00Hz	0.00	#
F6.16	Preset value arriving	0~9999	0	+
F6.17	Specified value arriving	0~9999	0	+

F6.18	Terminal logic	0~255	0	+
F7.00	AI1 Filter time	0.05~5.00s	0.50	#
F7.01	Minimum AI1	0.0~100.0%	0.0	#
F7.02	Frequency corresponding to F7.01	0.00~100.0% (Maximum output frequency)	0.00	#
F7.03	Maximum AI1	0.0~100.0%	100.0	#
F7.04	Frequency corresponding to F7.03	0.00~100.0% (Maximum output frequency)	100.0	#
F7.05	AI2 filter time	0.05~5.00s	0.50	#
F7.06	Minimum AI2	0.0~100.0%	0.0	#
F7.07	Frequency corresponding to F7.06	0.00~100.0% (Maximum output frequency)	0.00	#
F7.08	Maximum AI2	0.0~100.0%	100.0	#
F7.09	Frequency corresponding to F7.08	0.00~100.0% (Maximum output frequency)	100.0	#
F7.10	FWD/REV dead time range	0.0~10.0%	1.0	+
F7.11	Potentiometer input filter time	0.05~5.00s	0.50	#
F7.12	Potentiometer input minimum	0.0~100.0%	0.0	#
F7.13	Frequency corresponding to F7.12	0.00~100.0% (Maximum output frequency)	0.00	#
F7.14	Potentiometer input maximum	0.0~100.0%	0.0	#

F7.15	Frequency corresponding to F7.14	0.00~100.0% (Maximum output frequency)	100.0	#
F8.00	AO1 output selection	0: Running frequency 1: Frequency setting 2: Output current (Ie) 3: Output voltage	1	#
F8.01	reserved	4: Output torque 5: DC Bus Voltage 6: PI reference 7: PI feedback 8: AI1 9: AI2	1	#
F8.02	Minimum AO1	0.0~100.0%	0.0	#
F8.03	Minimum value corresponding to F8.02	0.0~100.0%	0.0	#
F8.04	Maximum AO1	0.0~100.0%	100.0	#
F8.05	Maximum value corresponding to F8.04	0.0~100.0%	100.0	#
F8.06	reserved	0.0~100.0%	0.0	#
F8.07	reserved	0.0~100.0%	0.0	#
F8.08	reserved	0.0~100.0%	100.0	#
F8.09	reserved	0.0~100.0%	100.0	#
F9.00	Program running function	0: Single cycle (Stop after a single cycle) 1: Continuous cycle 2: Maintain the final value	0	+
F9.01	Run time unit	0: Second 1: Minute	0	+

F9.02	Stage 1 timing T1	0~3600.0	0	+
F9.03	Stage 2 timing T2	0~3600.0	0	+
F9.04	Stage 3 timing T3	0~3600.0	0	+
F9.05	Stage 4 timing T4	0~3600.0	0	+
F9.06	Stage 5 timing T5	0~3600.0	0	+
F9.07	Stage 6 timing T6	0~3600.0	0	+
F9.08	Stage 7 timing T7	0~3600.0	0	+
F9.09	Stage 8 timing T8	0~3600.0	0	+
F9.10	Stage 9 timing T9	0~3600.0	0	+
F9.11	Stage 10 timing T10	0~3600.0	0	+
F9.12	Stage 11 timing T11	0~3600.0	0	+
F9.13	Stage 12 timing T12	0~3600.0	0	+
F9.14	Stage 13 timing T13	0~3600.0	0	+
F9.15	Stage 14 timing T14	0~3600.0	0	+
F9.16	Stage 15 timing T15	0~3600.0	0	+
F9.17	T1 running mode	0: FWD, Acc/Dec time 1	0	+
F9.18	T2 running mode	1: FWD, Acc/Dec time 2	0	+
F9.19	T3 running mode	2: FWD, Acc/Dec time 3	0	+
F9.20	T4 running mode	3: FWD, Acc/Dec time 4	0	+
F9.21	T5 running mode	4: REV, Acc/Dec time 1	0	+
F9.22	T6 running mode	5: REV, Acc/Dec time 2	0	+
F9.23	T7 running mode	6: REV, Acc/Dec time 3	0	+
F9.24	T8 running mode	7: REV, Acc/Dec time 4	0	+
F9.25	T9 running mode		0	+

F9.26	T10 running mode		0	+
F9.27	T11 running mode		0	+
F9.28	T12 running mode		0	+
F9.29	T13 running mode		0	+
F9.30	T14 running mode		0	+
F9.31	T15 running mode		0	+
F9.32	Record function	0: Disabled 1: Record, not store after power off 2: Record, store after power off	0	+
FA.00	PID control characteristic	0: Positive characteristic 1: Negative characteristic	0	+
FA.01	PID reference selection	0: Panel Digital setting 1: External analog signal AI1 2: External analog signal AI2 3: Communication	0	+
FA.02	Feedback channel selection	0: External analog signal AI1 1: External analog signal AI2	0	+
FA.03	Digital setting of reference	0.00~10.00V	5.00	#
FA.04	Minimum reference	0~100%	0	+
FA.05	Maximum reference	0~150%	100	+
FA.06	Minimum feedback	0~100%	0	+
FA.07	Maximum feedback	0~150%	100	+
FA.08	Proportional gain	0.00~10.00	1.00	#
FA.09	Integration time	0.01~99.99s	0.5	#
FA.10	differential time	0.00, no differentiation 0.01~99.99s	0	#
FA.11	Sample cycle	0.01~99.99s	0.1	#

FA.12	Error limit	0.0~15.0%	0.0	#
FA.13	Level of abnormal feedback signal	0~100%	50	#
FA.14	Detection time of abnormal feedback signal	0: No detection 0.1~3600s	0.0	#
FA.15	reserved		0	+
FA.16	PID Sleep control	0: No sleep function; 1: Internal waking up, 2. External input terminal	0	+
FA.17	Delay time of sleeping	0~3600s	0	+
FA.18	Sleeping frequency	0.00~400.0Hz	0.00	+
FA.19	Delay time of waking	0.0~60.0s	0.0	+
FA.20	Waking value	0.0~100.0%	100.0	+
FB.00	Traverse mode	0: Auto mode 1: Manual mode	0	+
FB.01	Preset traverse frequency	0.00~600.0Hz	0.00	#
FB.02	Hold time of preset traverse frequency	0.0~3600s	0.0	#
FB.03	Preset central frequency	0.00~600.0Hz	0.00	#
FB.04	Travers amplitude	0.0~50.0% (FB.03)	0.0	#
FB.05	Step frequency	0.0~50.0% (FB.04)	0.0	#
FB.06	Traverse cycle	0.1~999.9s	10.00	#
FB.07	Rise time of triangular wave	0.0~100.0% (FB.06)	50.0	#
FC.00	Baud rate selection	0: 1200BPS 1: 2400BPS	3	+

		2: 4800BPS 3: 9600BPS 4: 19200BPS 5: 38400BPS		
FC.01	Data format	0: 8,N,2 for RTU (MODBUS) 1: 8,E,1 for RTU (MODBUS) 2: 8,O,1 for RTU (MODBUS) 3: 7,N,2 for ASCII (MODBUS) 4: 7,E,1 for ASCII (MODBUS) 5: 7,O,1 for ASCII (MODBUS) 6: 8,N,1 free communication format 7: 8,E,1 free communication format 8: 8,O,1 free communication format 9: Host mode, send current running frequency	0	+
FC.02	Local address	1~32, 0 is the broadcast address	1	+
FC.03	Communication timeout detect	0, No detection 2.0~10.0s	0	+
FC.04	Response delay	2~1000ms		+
FC.05	EEROM Store selection	0: Store 1: no store function	0	+
FD.00	Motor overload protection mode	0: No protection 1: Common motor protection 2: Variable frequency motor protection	1	+
FD.01	Motor overload protection factor	20.0~150.0%	100.0	+
FD.02	Over voltage stall selection	0: Disabled 1: Enabled	1	+
FD.03	Stall over voltage point	115.0~150.0% (UDC)	120.0	+
FD.04	Selection of overload pre-alarm	0: Detect at constant speed and alarm 1: Detect all the time and alarm	0	+

	detection			
FD.05	Overload detection threshold	20.0~180.0% (I _e)	150.0	+
FD.06	Overload pre-alarm delay	0.0~60.0s	2.0	+
FD.07	Auto current limiting threshold	20.0~180.0%	150.0	+
FD.08	Frequency decrease rate during current limiting	0.00~99.99Hz/s	0.00	+
FD.09	Action mode of auto current limiting	0: Disabled 1: Enabled during Acc/Dec, disabled at constant speed 2: Enabled during Acc/Dec, enabled at constant speed	1	+
FD.10	Auto reset	0: Disabled 1~5: Times of fault reset	0	+
FD.11	Auto reset interval	2.0~20.0s	2.0	+
FD.12	Relay action in Auto reset	0: No action 1: action	0	
FD.13	Act selection at under voltage fault	0: No action 1: Act in running state 2: Act in running and stop state	1	+
FD.14	reserved		1	+
FD.15	reserved		1	+
FD.16	Under Voltage Point	380V: 250-440 220V: 200-260	380V:400 220V:250	+
FD.17	reserved			+
FD.18	reserved			+

FD.19	reserved			+
FD.20	reserved			+
FE.00	Keyboard frequency setting lock function	0: Keyboard frequency settings are not locked, you can change the frequency of the inverter settings by keyboard keys 1: Keyboard frequency setting lock, can not change the setting frequency of the inverter by keyboard increase key and decrease keys, You can only change the setting frequency of the inverter by changing the F0.11	0	+
FE.01	Terminal start delay	0.1-20.0s	0	
FE.02	Terminal stop delay	0.1-20.0s	0	
FE.03	MODBUS respond	0: The Modbus protocol responds to the write command 1: The Modbus protocol does not respond to write commands	0	
FE.04	Acceleration and deceleration time switching frequency	When the frequency is not equal to 0, less than FE.04, the Acc/Dec time is 1, otherwise the Acc/Dec time is 2	0.00	+
FF.xx	Reserved	Reserved	Reserved	
FH.00	Running display parameters selection	0: Frequency setting 1: Running frequency 2: Output current 3: Output voltage 4: Bus voltage 5: Overload rate 6: Preset line speed 7: Running line speed	1	#

		8: Output torque 9: PI reference 10: PI feedback 11: Reserved 12: Analog input AI1 13: Analog input AI2 14: I/O status 15: External counting value		
FH.01	Display parameters at stop	0: Frequency setting 1: Preset line speed 2: DC Bus voltage 3:Reserved 4: Analog input AI1 5: Analog input AI2 6: I/O status 7: external counting value 8: PI reference 9:PI feedback	0	#
FH.02	Line speed factor	0.01~99.99	30.00	#
FH.03	Inverter Power			*
FH.04	Heat sink temperature 1	0~100		*
FH.05	Heat sink temperature 2	0~100		*
FH.06	1st fault type			*
FH.07	2nd fault type			*
FH.08	3rd fault type			*
FH.09	Bus voltage at last fault			*
FH.10	Output current at last fault			*

FH.11	Frequency setting at last fault			*
FH.12	Running frequency at last fault			*
FH.13	I/O state at last fault			*
FH.14	Total operating time			*
FH.15	Software version of CPU Board			*
FH.16	Software version of Keypad Board			*

Chapter 6 Detail Function Introduction

F0 Basic function parameters

F0.00 Reserved	
0.01 Running command selection	Setting range: 0, 1, 2

Select physical channel of inverter's running control command, common running commands include:

Start, Stop, FWD and REV;

0: Running command issued by Keypad

Running command is issued by pressing the keys on Keypad, such as RUN, STOP/RESET, JOG, etc.

1: Running command issued by External terminals

Running command is issued by external terminals, such as FWD, REV, JOGF and JOG (terminal function must be defined).

2: Running command issued by RS485 serial communication port

Running command can be issued through internal RS485 serial communication port by host.

F0.02 Control mode	Setting range: 0~1
--------------------	--------------------

0: Sensorless vector control

That is no speed sensor vector control running mode, which can be used for high performance variable speed general driving condition.

Note:

A. At the first running when vector control mode is selected, please perform motor auto-tuning to get accurate parameters of motor. After auto-tuning, motor parameters will be saved in the internal control board for control operation.

B. To ensure high steady/dynamic control performance, user must set parameters of speed controller correctly. For parameters setup and adjustment of speed controller, please refer to explanation of F5 parameter group.

C. If vector control mode is selected, one SINUS MINI can only drive one motor. At this time, motor capacity can be one level higher (full load is forbidden) or lower than that of the inverter. Different of capacity between inverter and motor should not be too large, otherwise, the inverter's control performance drops or drive system cannot operate normally.

1: V/F control

When one inverter drives more than one motor, if motor auto-tuning cannot be performed or the motor's parameters cannot be acquired through other methods, please select V/F control mode.

F0.03 Main Frequency Source	Setting range: 0~9
-----------------------------	--------------------

SINUS MINI series inverter has ten kinds of frequency setting mode.

0: Keyboard settings, set the current frequency by digital settings F0.11, adjust the inverter through the keyboard up and down key

1: Keyboard potentiometer

2: External analog signal AI1 (0~10V or 0~20mA)the voltage / current signal is determined by the J4 jumper selection

Use external analog signal AI1to set the running frequency

3: External analog signal AI2(0~10V or 0-20mA),the voltage / current signal is determined by the J5 jumper selection

4: up/down 1 setting

Present frequency is set by terminal defined by up/down function. Frequency setting is held when the drive stops.

5: up/down 2 setting

Present frequency is set by terminal defined by up/down function. Frequency setting is the data of F0.11 when the drive stops

6: Multi Frequency

You need to set relevant parameter of the F6 I/O and F2 ,When choose multi frequency operational mode

7: PID

You need to set relevant parameter of the FA and PID ,When choose PID operational mode

8: RS485 setting

Frequency setting is set by host computer via RS485 serial communication command.

9: Program running

When inverter begins running, need to set F9 parameter.

F0.04 Main Frequency gain	Setting arrange: 0.000~9.999
---------------------------	------------------------------

The main frequency is the product of the setting frequency selected by parameter F0.03 and this gain.

F0.05 Zero frequency source of multi-speed mode	Setting arrange: 0~3
-------------------------------------------------	----------------------

0: Digital frequency of F0.11

1: Reserved

2: External analog signal:AI1

3: External analog signal:AI2

4: Communication given

F0.06 Auxiliary frequency setting	Setting arrange: 0~4
-----------------------------------	----------------------

SINUS MINI series inverter has 4 kinds of auxiliary frequency setting mode

0: External analog signal AI1(0~10V or 0~20mA) the voltage / current signal is determined by the J4 jumper selection

1: External analog signal AI2(0~10V or 0~20mA) the voltage / current signal is determined by the J5 jumper selection

2: External analog signal AI1(0~10V or 0~20mA) (+/- polarity)

3: External analog signal AI2(0~10V or 0~20mA) (+/- polarity)

4: PID

5: Keyboard Increase and decrease key

When F0.06=2, 3, Polarity control of external analog AI1 and AI22 is shown in Fig. 6-1, With 5v as the analog input, the center point is 0-5v negative adjustment and 5v-10v forward regulation.

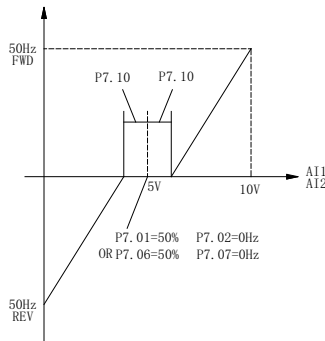

Fig6-1 Polarity control of external analog signal

F0.07 Auxiliary frequency range selection	Setting range: 0~1
-------------------------------------------	--------------------

When the F0.09 is used to determine the range of the auxiliary frequency settings

0: Maximum output frequency

1: Main frequency

F0.08 Auxiliary frequency range	Setting range: 0~100%
---------------------------------	-----------------------

The auxiliary frequency is the product of the setting frequency selected by parameter F0.07 and this gain.

F0.09 Setting Frequency selection	Setting range: 0~9
-----------------------------------	--------------------

Select the setting frequency source of the inverter. The frequency is given through a combination of the frequency setting and the auxiliary frequency setting

0: Main frequency

The setting frequency source of the inverter is determined by the main frequency of the parameter of F0.03.

1: Auxiliary frequency

The setting frequency source of the inverter is determined by the auxiliary frequency of the parameter of F0.06.

2: Main frequency + Auxiliary frequency

3: Main frequency - Auxiliary frequency

4: switch between main frequency and auxiliary frequency

The setting frequency source of the inverter can be switched between the main frequency and auxiliary frequency with the external terminal defined by F6 Group parameter.

5: switch between Main frequency and (Main frequency + Auxiliary frequency)

The setting frequency source of the inverter can be switched between the main frequency and (Main frequency + Auxiliary frequency) with the external terminal defined by F6 Group parameter.

6: switch between Main frequency and (Main frequency - Auxiliary frequency)

The setting frequency source of the inverter can be switched between the main frequency and (Main frequency - Auxiliary frequency) with the external terminal defined by F6 Group parameter.

7: MAX (Main frequency, Auxiliary frequency)

The setting frequency source of the inverter is maximum of main frequency and auxiliary frequency

8: MIN (Main frequency, Auxiliary frequency)

The setting frequency source of the inverter is minimum of main frequency and auxiliary frequency

9: Traverse operation

The setting frequency source of the inverter is determined by traverse operation mode defined by function code FB parameter group.

F0.10 Keyboard and up/down setting store selection	Setting range: 0、1
----------------------------------------------------	--------------------

0: Store

The initial frequency setting value is the value of parameter F0.11. It can be changed by the terminal defined with function UP/DOWN. When the inverter is power off, the current frequency setting value is stored.

1: Not Store

The initial frequency setting value is the value of parameter F0.11. It can be changed by the terminal defined with function UP/DOWN. When the inverter is power off, the current frequency setting value is not stored.

F0.11 digital frequency setting	Setting range: 0.00~High frequency limit
---------------------------------	------------------------------------------

If digital frequency setting via panel is selected, the value of parameter, will be the present preset frequency.

F0.12 Rotating direction	Setting range: 0, 1
--------------------------	---------------------

If panel control mode is selected, select the relationship between inverter's actual output direction and the direction of control command.

- 0: Same with control command;
- 1: Opposite to control command

F0.13 Maximum output frequency	Setting range: 50Hz~600.0Hz
F0.14 High frequency limit	Setting range: 0.00Hz~ Maximum output frequency
F0.15 Low frequency limit	Setting range: 0.00Hz~Upper frequency limit

The maximum output frequency is the maximum frequency which the inverter is able to output, shown in Fig. 6-2 as F_{max} ;

High frequency limit is the maximum frequency which the user is allowed to set, shown in Fig. 6-2 as f_H ;

Low frequency limit is the minimum frequency which the user is allowed to set, shown in Fig. 6-2 as f_L ;

f_b in Fig.6-2 is basic running frequency, which is defined as the lowest output frequency when the inverter outputs the highest voltage in V/F control mode.

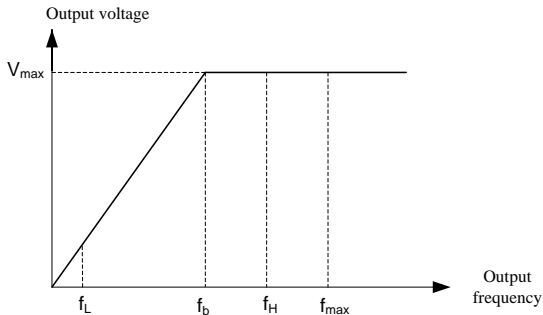

Fig.6-2 Frequency limits definition

F0.16 Acc time 1	Setting range: 0.1~3600s
F0.17 Dec time 1	Setting range: 0.1~3600s

Acc time means the time during which the inverter output from zero frequency to the maximum output frequency, shown in Fig. 6-3 as $T1$.

Dec time means the time during which the inverter outputs from the maximum output frequency to zero frequency, shown in Fig. 6-3 as T2.

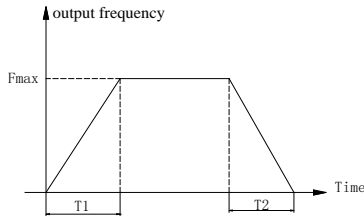

Fig 6-3 Definition of Acc/Dec time

Factory setting of Acc/Dec time: Acc/Dec time 1 (F0.16、F0.17)。

Other Acc/Dec time must be selected through control terminals according to different groups (Please refer to F2 parameter group)。

When program is running, selection of Acc/Dec time group is setup in function code (Please refer to F9 parameter group).

F0.18 reserved	Setting range: 0, 1
F0.19 parameter initialization	Setting range: 0~4

0: No operation

Inverter is in normal parameter read/write state.

1: Clear fault information

The fault information clearing operation will clear all the memorized parameters stored in the function codes between FH.06~FH.13

2: Recover factory settings without motor parameters.

Setup F0.19 to 2 and confirm, inverter will recover all the parameters between F0~F2 and F4~FH to the default factory setting value.

All the setting values of F3 parameter group will not be influenced when factory setting value is restored.

3: Recover factory settings include motor parameters

Setup F0.19 to 3 and confirm, inverter will recover all the parameters include motor parameters.

4: parameter locking

When set F0.19 to 4, parameter locking function is enabled. Except this parameter, all other parameters are read only and can not be modified.

F1 Auxiliary function parameters 1

F1.00 start mode	Setting range: 0~1
------------------	--------------------

0: Start from starting frequency

When inverter begins running, it starts from starting frequency (F1.01) and runs for the preset time (F1.02) at this frequency according to the setting values of F1.01 and F1.02; then it enters normal Acc mode according to preset Acc time and Acc/Dec mode parameters, at last it accelerates to preset frequency.

1: Brake first then start from starting frequency

When inverter begins running, it starts DC injection braking process according to the preset DC injection braking voltage and time defined in F1.03 and F1.04. It starts from starting frequency, and runs for the preset time at this frequency; and then enters normal Acc mode according to preset Acc time and Acc/Dec mode parameters, and at last accelerates to preset frequency. The process is shown in Fig. 6-4.

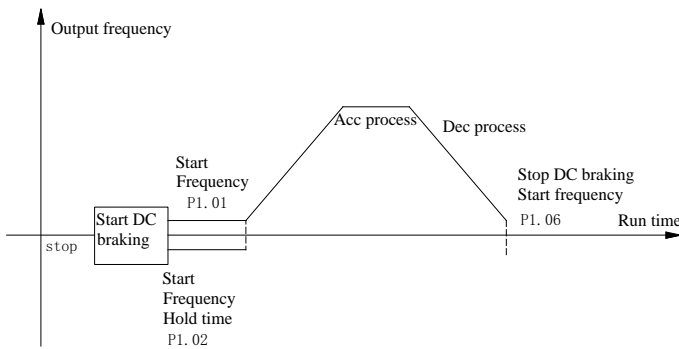

Fig. 6-4 Start mode 1 (FWD, REV, Stop and RUN) diagram

F1.01 Starting frequency	Setting range: 0.50~20.00Hz
F1.02 Hold time of starting frequency	Setting range: 0.00~60.0s

Start frequency: It is the initial frequency when the inverter starts from zero frequency, which is shown in Fig. 6-4.

In the Acc and Start process, if the preset frequency is lower than the start frequency, inverter's output frequency becomes zero;

Start frequency holding time: the running time at start frequency in Acc/Start process, which is shown in Fig. 6-4.

F1.03 DC injection braking time at start	Setting range: 0.00~60.0s
F1.04 DC injection braking current at start	Setting range: 0.0~100.0% (inverter rated current)

DC braking time at start: holding time for output DC injection braking current when the inverter is in start process.

If DC injection braking time at start is set to 0.0 second, DC injection braking function is disabled.

DC braking current at start: percentage of braking voltage when the inverter starts in DC injection braking process.

F1.05 Stop mode selection	Setting range: 0, 1, 2
---------------------------	------------------------

0: Dec-to-stop mode 1

When the inverter receives stop command, it lowers its output frequency and decelerates to stop according to the preset Dec time. During Dec process, for inverter with braking resistor or unit, it will enter dynamic braking.

1: Dec-to-stop mode 2

After the inverter receives stop command, it lowers its output frequency and decelerates to stop according to the preset Dec time. During Dec process, when output frequency is equal to the frequency set by F1.06, the inverter starts DC braking according to the DC braking time and voltage defined by F1.07 and F1.08.

2: Free run to stop

After the inverter receives the stop command, it stops its output immediately; the motor will decelerate to stop according to its inertia.

F1.06 Initial frequency of DC injection braking	Setting range: 0.00~20.00Hz
-------------------------------------------------	-----------------------------

Initial frequency of DC injection braking: It is the frequency when the inverter's output frequency is decreased to zero along the Dec curve in Dec-to-stop process, which is shown in Fig. 6-4.

In the process of Dec-to-stop, when the preset frequency is lower than the initial frequency of Stop DC injection braking, the inverter's output frequency is decreased to zero.

If the running condition has no strict requirements for braking, the initial frequency of DC injection braking should be set as low as possible.

F1.07DC injection braking time	Setting range: 0.0, 0.1~60.0s
F1.08 DC injection braking current	Setting range: 0.0~100.0% (inverter's rated current)

DC injection braking time:the time for maintaining output DC injection braking in inverter's stopping process.

DC injection braking current: percentage of braking voltage when the inverter stops in DC injection braking mode.

When the DC injection braking time is set to0 second., the DC injection braking function is disabled.

F1.09 Acc/Dec mode selection	Setting range: 0, 1
------------------------------	---------------------

- 0: linear mode
- 1: Reserved

F1.10 Reserved	0
F1.11 Reserved	0
F1.12 Restart after power failure	Setting range: 0, 1

- 0: Disabled;
- 1:Enabled; Function of restarting after power failure is enabled when the power supply recovers.

F1.13 Delay time for restarting after power failure	Setting range: 0.0~20.0s
-----------------------------------------------------	--------------------------

When the power recovers from failures, the time before the inverter restarts is the delay time. This time is set according to the time needed by other equipment to recover when the power supply recovers.

F1.14 dynamic braking start voltage	380V voltage level Setting range: 630~710V 220V voltage level Setting range: 350~380V
-------------------------------------	------------------------------------------------------------------------------------------

Setting the start voltage of dynamic braking.

F1.15Rate of dynamic braking	Setting range: 0.0 ~100.0%
------------------------------	----------------------------

Define duty cycle of dynamic braking.

- 0: No dynamic braking
- 1%~100%: In process of dynamic braking, percentage of valid braking time to carrier cycle, user can modify this value if necessary.

F1.16Start frequency lower than frequency limit	Setting range:0, 1,2
-------------------------------------------------	----------------------

- 0:when preset frequency is lower than low frequency limit, the inverter will not start;
- 1:when preset frequency is lower than low frequency limit, the inverter will start at low frequency limit;
- 2:When preset frequency is lower than frequency limit, the inverter stop.

F1.17 M key function	
----------------------	--

- 0: No operation;
- 1: forward rotation
- 2: reverse rotation

F1.18 Stop/reset Key function	Setting range: 0、1、2
-------------------------------	----------------------

This parameter decides the “stop” function of STOP/RESET key of the Keypad in different command source. The “Reset”function is usable in all command source.

- 0: action on Keypad control mode
- 1: action on both Keypad and External terminal
- 2: action on both Keypad and communication

F1.19 Fan control function	Setting arrange: 0、1
----------------------------	----------------------

- 0: Cooling fan always runs after power on
- 1: Cooling fan stops fan after inverter stop running

F2 Auxiliary function parameters 2

F2.00 Acc time2	Setting arrange: 0.1~3600s
F2.01 Dec time2	Setting arrange: 0.1~3600s
F2.02 Acc time3	Setting arrange: 0.1~3600s
F2.03 Dec time3	Setting arrange: 0.1~3600s
F2.04 Acc time4	Setting arrange: 0.1~3600s
F2.05 Dec time4	Setting arrange: 0.1~3600s

Four Acc/Dec times are defined as following:

phases of Acc/Dec time		1	2	3	4
Terminal state	DI4	OFF	ON	OFF	ON
	DI5	OFF	OFF	ON	ON

As shown in the table above, in normal operation condition, Acc/Dec time 1 is the default setting (both terminals DI4, DI5 are OFF, and Acc/Dec time 1 and 2 are defined by terminal DI4 and DI5 respectively).

F2.06 Jog Acc time 1	Setting range: 0.1~20.0s
F2.07 Jog Dec time 1	Setting range: 0.1~20.0s
F2.08 Jog frequency	Setting range: 0.5~60.00Hz

F2.06~F2.08 define the jog running parameters, which is shown in Fig. 6-7.

In Fig. 6-7, f_1 is Jog running frequency (F2.08), t_1 is Jog Acc time (F2.06), t_3 is Jog Dec time (F2.07), and t_2 is the Jog running time.

Jog running command can be issued through panel, control terminal or host computer.

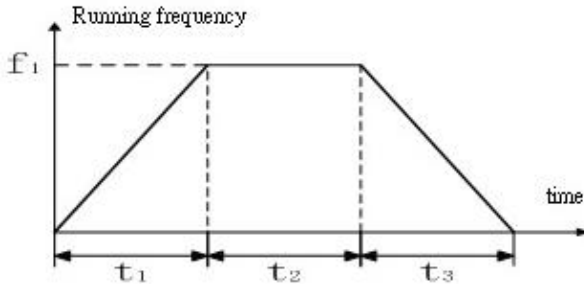

Fig. 6-7 Jog running parameters

F2.09 Multi-frequency 1	Setting range: 0~600.0Hz
F2.10 Multi-frequency 2	Setting range: 0~600.0Hz
F2.11 Multi-frequency 3	Setting range: 0~600.0Hz
F2.12 Multi-frequency 4	Setting range: 0~600.0Hz
F2.13 Multi-frequency 5	Setting range: 0~600.0Hz
F2.14 Multi-frequency 6	Setting range: 0~600.0Hz
F2.15 Multi-frequency 7	Setting range: 0~600.0Hz
F2.16 Multi-frequency 8	Setting range: 0~600.0Hz
F2.17 Multi-frequency 9	Setting range: 0~600.0Hz
F2.18 Multi-frequency 10	Setting range: 0~600.0Hz
F2.19 Multi-frequency 11	Setting range: 0~600.0Hz

F2.20	Multi-frequency 12	Setting range: 0~600.0Hz
F2.21	Multi-frequency 13	Setting range: 0~600.0Hz
F2.22	Multi-frequency 14	Setting range: 0~600.0Hz
F2.23	Multi-frequency 15	Setting range: 0~600.0Hz

Multi-frequency/speed is set in F2.09~F2.23, which can be used in multi-speed running and programming state.

There are 15 multi-frequency operation modes, which can be selected through control terminals.

Assumption:

“1 (ON)” means that control terminal is connected;

“0 (OFF)” means that control terminal is disconnected.

If control terminals of multi-frequency are not set, or all of them are in OFF position, frequency setting is determined by function code F0.05;

If certain control terminal of multi-frequency is not in OFF position, frequency setting is determined by function code F2.09~F2.23;

If multi-frequency operation is selected, Starting/stopping the drive is determined by control mode selection F0.01.

Frequency	1	2	3	4	5	6	7	8	9	10	11	12	13	14	15
Terminal	X	X	X	X	X	X	X	X	X	X	X	X	X	X	X
Terminal 1	1	0	1	0	1	0	1	0	1	0	1	0	1	0	1
Terminal 2	0	1	1	0	0	1	1	0	0	1	1	0	0	1	1
Terminal 3	0	0	0	1	1	1	1	0	0	0	0	1	1	1	1
Terminal 4	0	0	0	0	0	0	0	1	1	1	1	1	1	1	1

F2.24	Jump frequency 1	Setting range: 0~600.0Hz
F2.25	Jump frequency 2	Setting range:0~600.0Hz
F2.26	Jump frequency 3	Setting range:0~600.0Hz
F2.27	Jump frequency range	Setting range:0~20.00Hz

Jump frequency is set to prevent the output frequency of inverter from meeting the mechanical resonant point of load.

In Jump frequency parameters, set the system's mechanical resonant central frequency, at most three frequency values can be setup, shown in Fig.6-8.

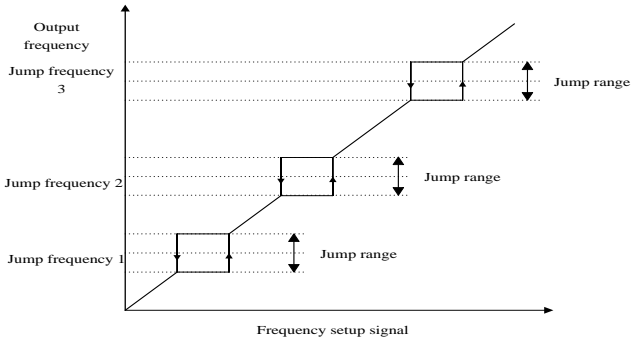

Fig. 6-8 Jump frequency and its range

F2.28 FWD/REV dead time	Setting range: 0.1~3600s
-------------------------	--------------------------

FWD/REV dead time: the waiting and holding time before the motor changes its rotating direction after the inverter's output frequency is decreased to zero. It is the time taken by the motor to change its rotating direction when the inverter receives REV command during its running process. The time is shown in Fig. 6-9 as T0.

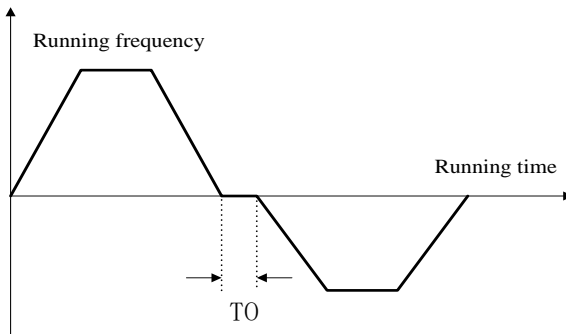

Fig. 6-9 FWD/REV dead time

F2.29 REV prohibited	Setting range: 0, 1
----------------------	---------------------

When F2.29=0, this function is disabled. In this case, terminal F/R=OFF, Run FWD; terminal F/R=ON, Run Rev;

When F2.29=1, this function is enabled. In this case, terminal F/R signal is invalid. Motor can only run forward, and switching between FWD/REV is not available.

Running mode of routine program is independent of this function.

In traverse operation mode, both FWD and REV running are allowable, but switching between FWD/REV is prohibited. Setting FWD/REV direction may not be same as actual direction, which can be defined by changing phase sequence of the output.

F2.30 Carrier frequency adjustment	Setting range:2.0~12.0KHz
------------------------------------	---------------------------

Carrier wave frequency can be continuously adjusted within 2.0~12.0KHz.

This function is mainly used to improve system performance, and reduce noise and vibration.Since SINUS MINI series adopts IGBT as power devices, carrier frequency can be higher. Increasing carrier frequency can bring following benefits: better current waveform, lower noise, which is especially suitable for applications that need low noise. However, with the increase of carrier frequency, it also brings some disadvantages, such as increase of power loss on switching devices, overheat, low efficiency, etc. Since high frequency carrier produces severe radio interference, please install filter for application with high requirement on EMI. At the same time, capacitive leakage current increases, and the wrong action of leakage protector and over current may happen.

Decreasing carrier frequency, the contrary is the case. Motor noise will increase in lower carrier frequency. Influence of carrier frequency is different for various motors. Therefore, optimal carrier frequency should be selected according to practical situation. In fact, with the increase of motor capacity, carrier frequency should decrease. For motor capacity above 37 kW, 2KHz carrier frequency is recommended.

F2.31 Zero frequency threshold	Setting range: 0~600.0Hz
F2.32 Zero frequency hysteresis	Setting range: 0~600.0Hz

The above two parameters are to set zero frequency hysteresis control.

Take analog input AI1 for example, see Fig.6-10:

Start-up process:

When the Run command is issued, only after AI1 voltage arrives or exceeds VS-b, does the drive start and accelerate to the preset frequency in defined Acc time.

Stop process:

During Dec process, when AI1 voltage reduces to VS-b, the drive will not stop until it reaches VS-a and the corresponding frequency becomes fa, where fa is the threshold of zero frequency defined by F2.31, and fb, fa is defined by F2.32.

This function can realize dormancy to save energy, in this way, frequent start and stop at threshold frequency can be avoided.

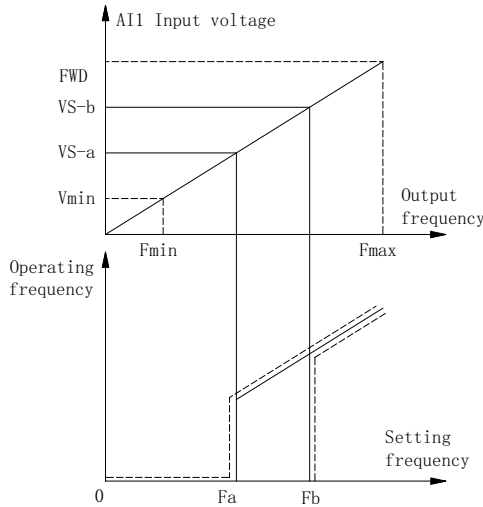

fa: Zero frequency threshold

fb: fa + Zero frequency hysteresis

Fig. 6-10 Zero Frequency Hysteresis

F2.33 Droop control	Setting range: 0.00~10.00Hz
---------------------	-----------------------------

When several inverter drives one load, the load of individual inverter is different due to speed different. The inverter with higher speed drives more load. This parameter can decrease the speed when the load is increased and equalizes the load of inverters.

F3 Motor parameters

F3.00 Motor rated power	Setting range:0.4~999.9kW
F3.01 Motor rated voltage	Setting range:0~440V
F3.02 Motor rated current	Setting range:0.1~999.9A
F3.03 Motor rated frequency	Setting range:1.00~600.0Hz
F3.04 Motor rated speed	Setting range: 1~999 rpm

Note:

In order to ensure motor tuning, please set nameplate parameter of the motor correctly.

In order to ensure high control performance, the motor capacity should match that of the drive. Generally the motor's power is allowed to be one grade higher or lower that of the drive.

F3.05 Motor auto-tuning	Setting range: 0, 1,2
-------------------------	-----------------------

Note: Before tuning, the parameters on the nameplate of the motor must be input correctly (F3.00~F3.04).

0: No operation

1: static auto-tuning

If the load can not be unconnected from motor, user can adopt static auto tuning. First set F3.05 to 1, after confirmation, then press the RUN key on the Keypad, inverter will perform static auto-tuning functions.

2: overall auto- tuning

First set F3.05 to 2, after confirmation, then press the RUN key on the Keypad, inverter will perform overall auto-tuning functions. The overall auto- tuning includes static auto-tuning and spinning auto-tuning and the load must be unconnected form the motor.

Note:

- a. If over-current or over-voltage fault occurs during tuning process, user can adjust Add/Dec time (F0.16, F0.17) and torque boost (F4.07);
- b. Do not start tuning with load on motor;
- c. Make sure the motor is in stopping status before tuning, otherwise, the tuning can not be performed normally;
- d. Motor auto-tuning can only be performed in Keypad control mode(F0.01=0).

F3.06 Stator resistance	Setting range: 0.001-20.00%
F3.07 Rotor resistance	Setting range: 0.001-20.00%
F3.08 Self inductance	Setting range: 1.000~9.999
F3.09 leakage inductance	Setting range: 0.001~1.000
F3.10 Exciting current with no load	Setting range: 0.0~999.9A

Factory settings of F3.06~F3.10 are the parameters of motor that rated power matches the inverter. If user already knows the motor's parameters, just input the motor parameters directly. However, after successfully performing motor auto-tuning, value of F3.06~F3.10 will be updated automatically.

Resistance and inductance are the relative value of the nominal motor parameters.

$$\text{Resistance value} = (\text{real Resistance value}) * (1.732 * I) / V * 100\%;$$

$$\text{Inductance value} = (\text{real Inductance value}) * 2 * 3.14 * P * (1.732 * I) / V;$$

In above formula, V is motor rated voltage defined by F3.01 ; I is motor rated current defined by F3.02 ;

P is the motor rated frequency defined by F3.03.

These parameters are reference parameters for vector control, which will affect control performance directly.

F3.11 Reserved	
----------------	--

F4 Dedicated function for V/F control

F4.00 V/F curve control mode	Setting range: 0~4
------------------------------	--------------------

- 0: linear voltage/frequency mode (constant torque load), shown as curve 0 in Fig. 6-11;
- 1: Square voltage/frequency mode, shown as curve 1 in Fig. 6-11;
- 2: 1.5 times torque/frequency mode, shown as curve 2 in Fig. 6-11;
- 3: 1.2 times torque/frequency mode, shown as curve 3 in Fig. 6-11;
- 4: User defined V/F curve.

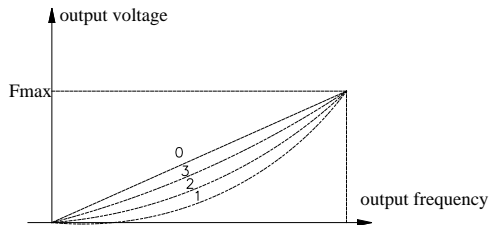

Fig. 6-11 V/F curve

F4.01 Base voltage	Setting range: 0~440V
F4.02 Base frequency	Setting range: 10.00~ 600.0Hz

Basic V/F characteristic of SINUS MINI series is shown in Fig. 6-12. Base Frequency F_{BASE} is the output frequency corresponding to the rated output voltage U_N . Its range is 10 to 600Hz. Generally, F_{BASE} should be selected according to rated frequency of the motor. In some special case, it can be selected according to requirement. In this condition, both motor V/F characteristic and output torque should be considered.

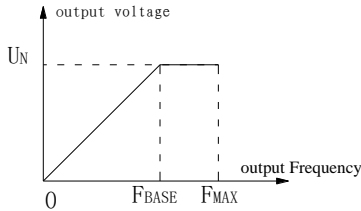

Fig. 6-12 Base voltage and frequency

F4.03Intermediate voltage 1	Setting range:0~F4.04
F4.04Intermediate voltage 2	Setting range:F4.03~100% (reference voltage F4.01)
F4.05Intermediate frequency 1	Setting range:0~F4.06
F4.06Intermediate frequency 2	Setting range: F4.05~600.0Hz
F4.07 Torque boost	Setting range:0~10%(reference voltage F4.01)

In order to compensate the torque drop at low frequency, the inverter can boost the output voltage in the low frequency zone, which is shown in Fig. 6-13.

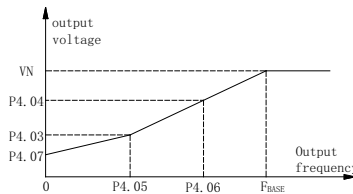

Fig. 6-13 Torque boost

Note:

Generally, factory setting (2%) can satisfy most applications. If over-current fault occurs during startup, please increase this parameter from zero gradually until it meets requirement. Pay attention that large torque boost could damage equipment.

F4.08 Slip compensation	Setting range: 0.0~10%(Rated speed F3.04)
-------------------------	-------------------------------------------

In V/F control mode, motor's speed will be decreased with load rising. In order to ensure the motor's speed be close to synchronous speed in rated load condition, slip compensation can be done according to the preset frequency.

F4.09 AVR function	Setting range:0, 1
--------------------	--------------------

0: Disabled; 1: Enabled

AVR is auto voltage regulation. When the inverter's input voltage differs with the rated input voltage, the inverter's output voltage can be stabilized by adjusting the width of PWM wave.

This function is disabled when the output voltage is higher than input voltage.

F5 Vector control funtion

F5.00 ASR proportional gain 1	Setting range:0.00~6.000
F5.01 ASR integration time 1	Setting range:0.00~9.999
F5.02 ASR proportional gain 2	Setting range:0.00~6.000
F5.03 ASR integration time 2	Setting range:0.00~9.999
F5.04 ASR switching frequency	Setting range:0.0~99.99Hz

Through F5.00~F5.04, user can set the proportional gain P and integration time I of speed regulator, so as to change the speed response characteristic.

a.Speed regulator (ASR)'s structure is shown in Fig.6-14, where K_p is proportional gain P, and K_i is integration time I.

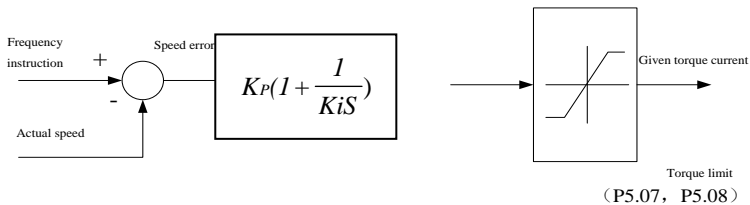

Fig. 6-14 Simplified block diagram of ASR

If the integral time is set to 0 (F5.01=0, F5.03=0), which means integral function is disabled, and the

speed loop is simply a proportion regulator.

b.Adjustment of proportion gain P and integration time I for speed regulator

Increasing P will fasten system transient response, but system oscillation may occur given too big P. Decreasing I will fasten transient response, but system oscillation and overshoot may occur given too small.

Normally, user may tune P first, increase its value as long as no system oscillation occurs; then adjust I, ensuring fast response without overshoot. Figure 6-15 shows better speed step response if P, I are set properly. Speed response can be monitored through analog terminals AO1. refer to F8 parameter group for detail information.

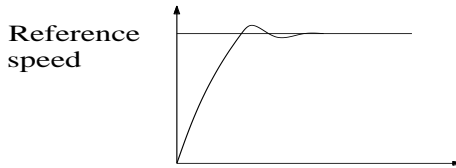

Fig. 6-15 Step response with better dynamic performance

Note:

With improper PI parameters, after accelerating to high speed, over-voltage during Dec process may occur (Without external braking resistor or unit), which is caused by regenerative braking after speed overshoot. To avoid this fault, user can tune PI parameters.

Adjustment of PI parameter in high/low speed applications

If system is required to respond quickly both in low and high frequency operation with load, user may set ASR switching frequency (F5.04). Normally, when the system runs at low frequency, the transient response performance can be improved by increasing P and decreasing I. Adjust ASR parameters following the procedures below:

Set appropriate switching frequency F5.04;

Tune proportional gain F5.00 and integration time F5.01 for low-speed application, and ensure no oscillation and good response performance at low frequency.

Next, tune proportional gain F5.02 and integration time F5.03 for high-speed application, and ensure no oscillation and good response performance at high frequency.

F5.05 Slip compensation gain	Setting range:50.0~200.0%
------------------------------	---------------------------

F5.05 is used to calculate slip frequency. Setting value 100% means rated slip frequency corresponds to rated torque current. User may decrease/increase the settings of F5.05 to adjust the speed control's different accurately.

Note:

This function is valid to open loop vector control mode. For close loop vector control mode, F5.05 can be set to 100% for most applications.

F5.06 Torque control	Setting range:0, 1
----------------------	--------------------

This function is reserved.

F5.07 Driving torque limit	Setting range:0.0~200.0% (motor's rated current)
F5.08 Braking torque limit	Setting range:0.0~200.0%(motor's rated current)

Torque limiting is used to limit output torque current of speed regulator'.

Torque limit is the percentage of the motor's rated current; If the torque limit is 100%, then the torque current limit is the motor's rated current. F5.07 and F5.08 limit the output torque in driving state and braking state respectively, which is shown in Figure 6-16.

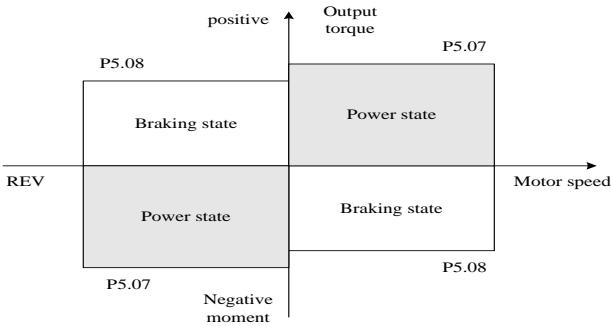

Fig. 6-16 Torque limit function

F5.09 Reserved	Reserved
F5.10 Reserved	Reserved

F6 I/O output terminal

F6.00 FWD/REV running	Setting range: 0~3
-----------------------	--------------------

0: Two-line operation mode 1

FWD	REV	Running command
0	0	Stop
0	1	REV
1	0	FWD
1	1	Stop

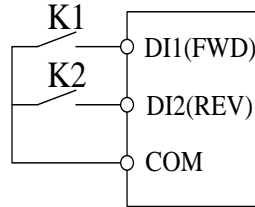

Fig. 6-17 Two-line control mode 1

In Fig. 6-17, terminal DI1 is defined as running FWD, and DI2 is defined as running REV.

1: Two-line operation mode 2

FWD	REV	Running command
0	0	Stop
0	1	Stop
1	0	FWD
1	1	REV

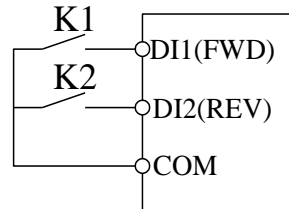
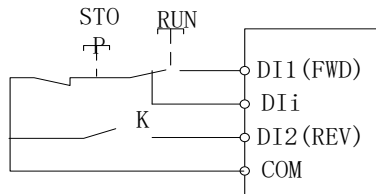

Fig.6-18 Two-line control mode 2

In Fig. 8-18, terminal DI1 is defined as running FWD, and DI2 is defined as running REV.

2: Three-wire operation mode 1

K	Running command
0	FWD
1	REV



i=3, 4, 5,

Fig. 6-19 Three-wire operation mode 1

3: Three-wire operation mode

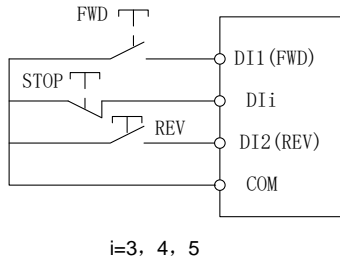

Fig. 6-20 Three-wire operation mode 2

In Fig.6-19 and 6-20, DI1 is defined as running FWD, DI2 is defined as running REV, and K is used for selecting running direction;

In Fig. 6-19 and 6-20, STOP is a normally closed button for stopping the motor. RUN, FWD and REV are normally open buttons for running the motor, and they are active at pulse edge.

In Fig. 6-19 and 6-20, DIi (i=3~5) is defined as three-wire running control terminal of DI3~DI5

In 3-wire mode, when DI3~DI5 is not selected, the inverter will report ERR4 fault.

F6.01 Up/down rate	Setting range:0.10~99.99Hz/s
--------------------	------------------------------

Up/down rate: To define the increase/decrease rate when using up/down terminal to change reference frequency.

F6.02 Selecting the function of control terminal DI1	Setting range:0~30
F6.03 Selecting the function of control terminal DI2	Setting range:0~30
F6.04 Selecting the function of control terminal DI3	Setting range:0~30
F6.05 Selecting the function of control terminal DI4	Setting range:0~30
F6.06 Selecting the function of control terminal DI5	Setting range:0~30

Control terminals DI1~DI5 are programmable digital input terminals. DI1~DI5 can be defined by setting the values of F6.02~F6.08 respectively.

Programmable digital input terminal can be selected as “ no function” repeatedly (that is, it can be set as 0 at the same time). Function description is shown below:

Content	Function	Content	Function
0	DI1~DI5: No function (can be selected repeatedly)	16	Free run to stop
1	Run FWD	17	Three-wire control
2	Run Rev	18	Voltage/current switching
3	External reset	19	Input terminal for recording program operation
4	Jog FWD (JOGF)	20	Start traverse operation
5	Jog REV (JOGR)	21	DC braking command
6	Multi-frequency 1	22	Acc/Dec disabled command
7	Multi-frequency 2	23	Switch between panel control mode and external terminal control mode
8	Multi-frequency 3	24	Counter trig signal
9	Multi-frequency 4	25	Counter reset signal
10	Terminals for selecting Acc/Dec time 1	26	PID dormancy waking up
11	Terminals for selecting Acc/Dec time 2	27	Counter reset signal
12	Normally open terminal for inputting external fault	28	PID dormancy waking up
13	Normally close terminal for inputting external fault	29	switch between PID positive mode and negative mode
14	Frequency increase command	30	Emergency stop
15	Frequency decrease command		

Note:

1. When DI1~DI4 is selected 0, no function is defined, When DI5 is selected 0, the pulse frequency is input

2. 1~2: input terminals for external operation control

In terminal control mode (F0.01=1), the terminal is used to select FWD/REV operation.

3. 3: External RESET

If fault alarm occurs, user can reset the inverter by external terminal. This function is active at rising edge of pulse signal. It has the same function as **STOP/RESET** key.

4. 4~5: Terminal for external FWD/REV Jog running control.

In terminal control mode (F0.01=1), this terminal is used to select Jog operation.

5. 6~9: Multi-frequency terminals

In multi-frequency operation mode, 4 digital input terminals should be defined as the control terminals. Through the combination of ON/OFF state of the 4 terminals, up to 15 values can be defined set as preset frequency. refer to parameter F2.09~F2.23 for details.

6. 10~11: Acc/Dec time terminals

By combination of the ON/OFF state of Acc/Dec time terminals, user can select Acc/ Dec time 1~4, refer to parameter F0.16,F0.17 and F2.00~F2.05 for more details. If this function is not defined, Acc/Dec time 1 will be the default setting except in simple PLC operation mode.

7. 12~13: Normally open terminal for external fault

Fault signal of external equipment can be input via the terminal, which is convenient for the drive to monitor the fault of external equipment. Once the drive receives the fault signal, it will display "Er11". During normal stop process, this function is disabled. The fault signal has two input modes, i.e. normally open and normally close.

8. 14~15: Frequency increase/decrease command

The running frequency can be set through external terminals, thus the running frequency can be set remotely. At this time,F0.03 can be set to 2 or 3. When the terminal is ON, the frequency setting value is increased or decreased at the rate defined by F6.01; when the terminal is OFF, frequency setting value keeps constant. When these two terminals are ON at the same time, frequency setting value also keeps constant. Please refer to F0.03 parameters description.

9. 16: Free run to stop terminal (FRS)

When the function terminal is ON, inverter stops output immediately and enter stopping state, the motor enters free run to stop state.

10. 17: Three-wire control

If F6.00=2 or 3, this terminal is defined as three-wire control terminal when three-wire control mode is selected. If F6.00=2 or 3, and none of DI1~DI5 is defined as three-wire control terminal, the inverter will report parameter setting fault ERR4. In this case, user should define "three-wire control terminal" first, and then define "three-wire control mode" (F6.00=2 or 3).

11.18: Switching input signal

If analog setting mode is selected, (F0.09=4、 5 or 6), this function is used to switch reference channel.

F0.09=4:

If this terminal is OFF, reference signal is decided by settings of master given

If this terminal is ON, reference signal is decided by settings of panel potentiometer

F0.09=5:

If this terminal is OFF, reference signal is decided by settings of master given

If this terminal is ON, reference signal is decided by settings of panel potentiometer +auxiliary given

F0.09=6:

If this terminal is OFF, reference signal is decided by settings of master given

If this terminal is ON, reference signal is decided by settings of panel potentiometer -auxiliary given

12.20: Start traverse operation

If the traverse operation is set to manual start, then traverse function is enabled if this function is selected. refer to FB parameter group for details.

13. 22: DC braking command

When the inverter is in Dec-to-stop process, and the running frequency is lower than initial frequency of DC injection braking defined in F1.06, this function is enabled. When the terminal is ON, DC injection braking is performed under braking voltage defined in F1.08. DC injection braking is ended only when the terminal is OFF.

When this function is enabled, parameters of DC injection braking time are invalid.

14.23: Acc/Dec disabled command

When the terminal is ON, the inverter temporarily inhibits executing the Acc/Dec command and runs at current frequency. When the terminal is OFF, normal Acc/Dec commands can be executed. If there is any control signal with higher priority input such as external fault signal, the inverter will exit Acc/Dec inhibit state immediately and execute specified processing procedures.

15.24: Switch between panel control mode and external terminal control mode

This function is used for selecting the physics channel that inputs inverter's running control command: Selecting between Keypad and external terminal to input control commands.

Commands input via external terminals include FWD, REV, JOGF, JOGR, RUN and STOP.

This function is used in conjunction with ON/OFF state and the setting value of F0.01.

The control logic is shown in the Table below.

F0.01	Terminal state	Source of control command
0	ON	External terminals
0	OFF	Keypad
1	ON	Keypad
1	OFF	External terminals

This function is enabled during running state. User should pay attention to the drive's running status after switching.

If the drive is in Keypad control mode first, connect the terminal (ON), there are 2 cases: if running command from external terminal is valid, such as FWD terminal is ON in two-wire control mode, then the drive's operation state will not change; if running command from external terminal is invalid, the drive will stop running.

16. 25: Switch between panel control mode and external terminal control mode

This function is used for selecting the physics channel that inputs inverter's running control command: Selecting between Keypad and external terminal to input control commands.

Commands input via external terminals include FWD, REV, JOGF, JOGR, RUN and STOP.

This function is used in conjunction with ON/OFF state and the setting value of F0.01.

The control logic is shown in the Table below.

F0.01	Terminal state	Source of control command
0	ON	External terminals
0	OFF	Keypad
1	ON	Keypad
1	OFF	External terminals

17.26: Counter trig signal

It is the input terminal of the drive's internal counter. If the input signal of the terminal changes from ON to OFF, the counting value is increased by 1.

18.27: Counter reset signal

This terminal is used to clear the inverter's internal counter, and is used in conjunction with Function 24 "Counter trig signal".

When the terminal is ON, internal counter is cleared to 0.

19. 28: PID dormancy waking up

When FA.17=2 and this terminal is ON, PID control will exit dormancy state and execute normal PID function.

20. 29: switch between PID positive mode and negative mode:

When FA.00 is set to 0, PID positive mode is selected with the terminal is off ; negative mode is selected with the terminal is on.

21. 30:"Emergency stop"

If the terminal defined with the function is on, the inverter is in emergency stop status(motor free stop)

F6.07 Terminal filter times	Setting range: 1~100
F6.08 Operation protection of power on terminals	Setting range: 0~1

F6.07: Set the number of software filtering times for the Dli terminal state. If the input terminal is vulnerable to interference in use, the parameter can be increased to enhance the anti-interference ability. However, the increase of the filter frequency will cause the corresponding slowing of Dli terminals.

F6.08:

This parameter relates to the inverter's security protection function.

If the parameter is set to 0, the frequency inverter will not respond to the running command if the power on the frequency inverter is effective (for example, before the power on the terminal running command is closed). The running command must be removed first, and the inverter will not respond until the running command is effective again.

In addition, if the parameter is set to 0, if the running command is effective at fault reset time, and the inverter does not respond to the running command, the running command must be removed before the running protection state can be eliminated.

This parameter is set to 0, which can prevent the motor from responding to the operation command in the case of power on or fault reset without knowing it.

F6.09 Programmable relay 1	Setting range: 0~20
F6.10 Output terminal Y1 definition	Setting range: 0~20

Function selection of programmable relay output terminals and open collector output terminals is shown in the table below.

Content	Function	Content	Function
0	Programmable relay 1: No operation Output terminal Y1: No operation	11	Over voltage stall
1	Drive ready	12	External stopping command
2	Drive running signal1	13	Preset counting value arriving
3	Drive running signal2	14	Specified counting value arriving
4	Frequency arriving signal	15	Low voltage lockup signal
5	Frequency detection threshold 1	16	Overload pre-alarm
6	Frequency detection threshold 2	17	Drive failure signal
7	High limit frequency arriving	18	Zero speed running
8	Low limit frequency arriving	19	Program running completed
9	Overload signal	20	PG cable broken
10	Over current stall		

Functions in the table above are described as following:

- 0 0: No function is defined by programmable relay output terminal 1, and open collector output terminal Y1. is defined as frequency signal output.
- 1 1: Drive ready
The drive is in normal waiting state, and terminals output indication signal.
- 2 2: Drive running signal I
The drive is in running state, and the terminal outputs indication signal.
- 3 3: Drive running signal 2
In run status, when the drive's output frequency is 0Hz, the terminal does not output indication signal; when the drive's output frequency is above 0Hz, the terminal does output indication signal
- 4 4: Frequency arriving signal
When the drive's output frequency arrives preset frequency, the terminal outputs indication signal. It is used in conjunction with parameter F6.11.
- 5 5-6: Frequency detection threshold 1 and 2

When the drive's output frequency arrives specified value, the terminal outputs indication signal, which is used in conjunction with parameters F6.12~F6.15.

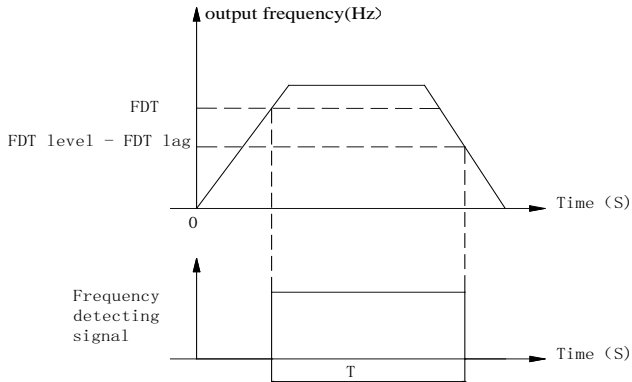

Fig. 6-21 Frequency detection threshold 1 and 2

6 7: High limit frequency arriving

When the drive's output frequency reaches high limit frequency, the terminal outputs indication signal.

7 8: Low limit frequency arriving

When the drive's output frequency reaches low limit frequency, the terminal outputs indication signal.

8 9: Overload signal

When overload occurs, the terminal outputs indication signal.

9 10: Over current stall

When over current stall occurs in running state, terminal outputs indication signal.

10 11: Over voltage stall

When over voltage stall occurs in running state, the terminal outputs indication signal.

11 12: External stopping command

During running process, when external fault signal is received by the digital input terminals, the drive reports ER11 fault, and the terminal outputs indication signal at the same time.

12 13: Preset counting value arriving

Set up counting value of the drive's internal counter. The drive inputs counting pulses via external terminals Dli (l=1~5), and the drive's internal counter counts this signal. When the preset value

arrives, Yi outputs an indication signal. When the next external counting pulse signal arrives, Yi 's output signal recovers, and the counter restarts to count again at the same time.

13 14: Specified counting value arriving

When Dli inputs external counting pulse signal and the counting value reaches specified value defined by F6.17 (See Fig. 6-22), Y1 outputs an indication signal, Y1 does not recover until specified value arrives.

As shown in Fig. 6-22, if F6.16=5, F6.17=3, when Dli inputs the 3th pulse, Y1 outputs an indication signal. When Dli inputs the 5th pulse, Y1 outputs specified value arriving signal. Y1 will recover when the 6th pulse arrives.

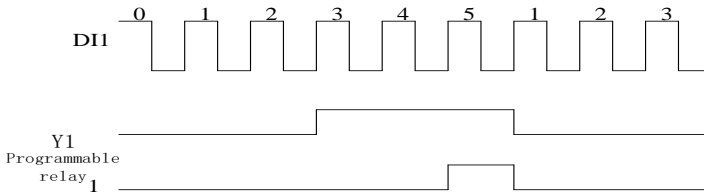

Fig. 6-22 Preset counting value arriving and specified counting value arriving

14 15: Low voltage lockup signal

When DC bus voltage is lower than the low voltage limit, the panel LED displays “LU”, and the terminal outputs indication signal at the same time.

15 16: Overload pre-alarm

According to FD.04–FD.06 overload pre-alarm setup, when the output current is higher than the setting value, the terminal outputs indication signal.

16 17: Drive failure signal

When fault occurs, the terminal outputs indication signal

17 18: Zero speed running

When the drive’s running frequency is zero, the terminal outputs indication signal.

For example, in the following three conditions the terminals output indication signal:

- FWD/REV dead time running period;
- The phase when the setup frequency is lower than the start frequency when the inverter starts from zero frequency;
- In Dec process output frequency is lower than initial frequency of DC injection braking.

18 19:End signal of stage of program operation

In program operation mode, when a stage is finished, the inverter outputs a pulse with width of 250ms.

19 20: End signal of stage of program operation

In program operation mode, when a cycle is finished, the inverter outputs a pulse with width of 250ms.

F6.11 Frequency arriving width (FAR)	Setting range:0.0~10.00Hz
--------------------------------------	---------------------------

When output terminal function is selected as frequency arriving signal, this function is used to detect output frequency range. When error between output frequency and setting value is less than FAR, the terminal outputs indication signal, as shown in Fig.6-24.

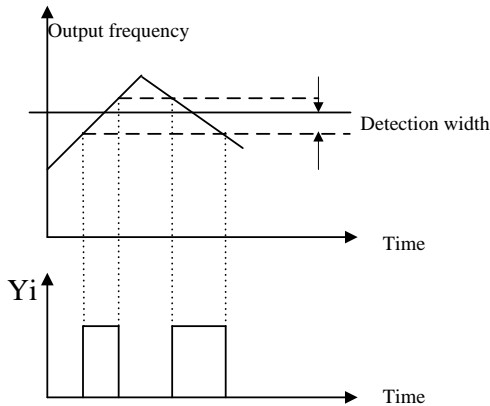

Fig.6-24 FAR and FAR detection width

F6.12 FDT1 level	Setting range: 0.0~600.0Hz
F6.13 FDT1 lag	Setting range: 0.0~10.00Hz
F6.14 FDT2 level	Setting range: 0.0~600.0Hz
F6.15 FDT2 lag	Setting range: 0.0~10.00Hz

If output frequency exceeds certain value, the terminal outputs indication signal, and this signal is called FDT level.

If output frequency decreases, the terminal continues to outputs indication signal, until the output frequency is lowered to the FDT signal width and exceeds certain width, this width is called FDT signal lag, as shown in Fig.6-21 and 6-23.

F6.16 Preset value arriving	Setting range:0~9999
F6.17 Specified value arriving	Setting range:0~9999

For F6.16 and F6.17 function, please refer to definition of terminal function 13, 14.

F6.18 Terminal logic	Setting range:0~255
----------------------	---------------------

This parameter defines positive or negative logic of terminals.

Y1	RESERVED	RESERVED	DI5	DI4	DI3	DI2	DI1
Bit7	Bit6	Bit5	Bit4	Bit3	Bit2	Bit1	Bit0

Note:

- a. If bit 0 is set to 0, it means positive logic, and 1 for negative logic. Factory setting of all terminals are positive logic;
- b. In positive logic mode, terminal Dli is enabled if it is connected to the common terminal, and disabled if disconnected;

In negative logic mode, terminal Dli is disabled if it is connected to the common terminal, and enabled if disconnected;

In positive logic mode, terminal Yi closes when its output signal is valid;

In negative logic mode, terminal Yi opens when its output signal is valid;

Only decimal number can be set to the drive (including display). When negative logic is selected, conversion from binary code to Hex value is shown as below:

$$\text{Setting value} = (2 \times Y1)^7 + (2 \times DI5)^4 + (2 \times DI4)^3 + (2 \times DI3)^2 + (2 \times DI2)^1 + DI1$$

For example,

if DI5 and DI4 select negative logic and others are positive logic, then:

$$\text{Setting value} = (2 \times 1)^4 + (2 \times 1)^3 + (2 \times 0)^2 + (2 \times 0)^1 + 0 = 16 + 8 = 24$$

F7 Analog input terminal function

F7.00	AI1 filter time	Setting range: 0.05-5.00S
F7.01	Minimum AI1	0.0-100.0%(10V)
F7.02	Frequency corresponding to F7.06	0.00 ~ Maximum frequency
F7.03	Maximum AI1	0.0-100.0%(10V)
F7.04	Frequency corresponding to F7.08	0.00 ~ Maximum frequency

F7.05	AI2 filter time	Setting range: 0.05-5.00s
F7.06	Minimum AI2	0.0-100.0%(10V/20mA)
F7.07	Frequency corresponding to F7.06	0.00 ~ Maximum frequency
F7.08	Maximum AI2	0.0-100.0%(10V/20mA)
F7.09	Frequency corresponding to F7.09	0.00 ~ Maximum frequency

reference signal from external input (AI1, AI2) is filtered and amplified, and then its relationship with frequency setting is shown as curve 1 in Fig. 6-25 or curve 2 in Fig.6-26.

AI2 can input current signal (4~20mA), F7.06 should be set to 20% except that S1 (AI2) is in “I” position,

F7.10	FWD/REV dead time range	Setting range: 0~10% Maximum input signal
-------	-------------------------	-------------------------------------------

If polarity control is selected (F0.06= 2 or 3), FWD/REV dead time is set by this parameter. refer to parameter F0.06 and fig 6-1 for details.

F7.11	AI0 filter time	Setting range: 0.05-5.00S
F7.12	Minimum AI0	0.0-100.0%
F7.13	Frequency corresponding to F7.12	0.00 ~ Maximum frequency
F7.14	Maximum AI0	0.0-100.0%
F7.15	Frequency corresponding to F7.13	0.00 ~ Maximum frequency

reference signal(AI1) from Keypad potentiometer is filtered and amplified, and then its relationship with frequency setting is shown as curve 1 in Fig. 6-25 or curve 2 in Fig. 6-26.

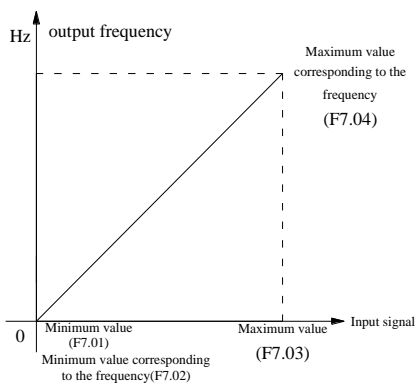

Fig. 6-25 curve 1: relationship between reference and frequency setting

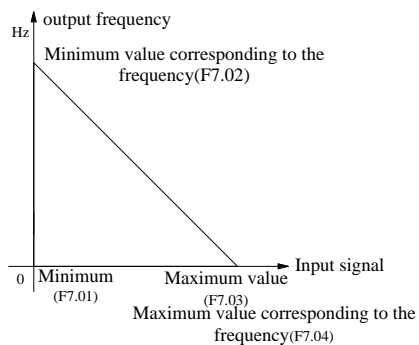

Fig. 6-26 curve 2: relationship between reference and frequency setting

F8 Analog output terminal

F8.00 AO1 output selection	Setting range:0~9
F8.01 Reserved	Reserved

Inverter's state represented by analog output signal is defined by the function codes F8.00, as shown below.

F8.00/F8.01	Drive state	Description
0	Running frequency/speed	0~ highest running frequency/speed
1	Frequency setting/speed	0~ highest running frequency/speed
2	Output current	0~ 2×rated current
3	Output voltage	0~+200% rated voltage
4	Output torque	-200%~+200% rated torque current
5	PI reference	0~ 10V
6	PI feedback	0~ 10V
7	Bus voltage	0-800V
8	Analog input AI1	0-10V/0-20mA
9	Analog input AI2	0-10V

F8.02 Minimum AO1	Setting range:0.00~100.0%
F8.03 Minimum value corresponding to F8.02	Setting range:0.00~100.0%
F8.04 Maximum AO1	Setting range:0.00~100.0%
F8.05 Maximum value corresponding to F8.04	Setting range:0.00~100.0%

This function code is used to setup maximum/minimum value of analog output signal (0~10V), and the relationship between these values and F8.00 is shown in Fig. 6-27 and 6-28.

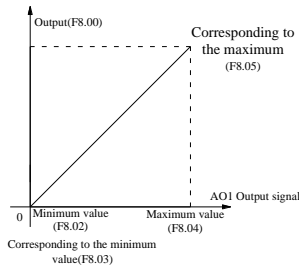

Fig. 6-27 Relationship between maximum/minimum AO1 and F8.00

For example, connect AO1 with a voltage meter (range: 0–5V) to indicate operating frequency, and the range of operating frequency is 0–50Hz (Maximum frequency=50Hz), then F8.00=0(=frequency), F8.02=0(=0V), F8.03=0(0Hz), F8.04=50%(=5V), F8.05=100%(=50Hz).

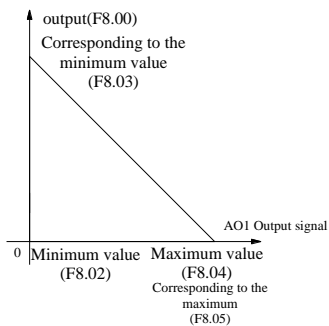

Fig. 6-28 Relationship between maximum/minimum AO1 and F8.00

F9 Program operating parameters

F9 parameter group is function code of programming operation.

Both programming operation and multi-frequency operation are used for realizing the inverter's variable speed running according to certain regulations.

One cycle of programming operation is shown in Fig. 6-29, $f_1 \sim f_7$ and $T_1 \sim T_7$ will be defined in the following function codes.

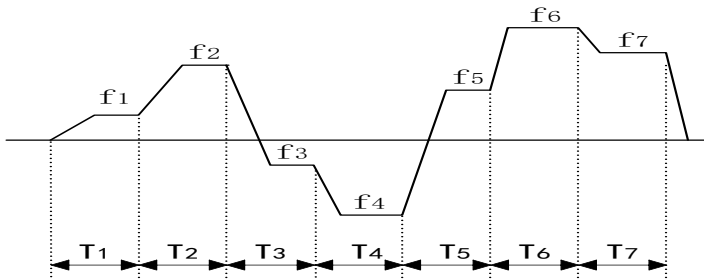

Fig. 6-29 Programming operation

F9.00 Programming operation function	Setting range:0, 1,2
--------------------------------------	----------------------

- 0: Single cycle (Stop after a single cycle)
- 1: Continuous cycle (Continue cycle operation according to setup phase parameters)
- 2: Maintain the final value (maintain the non-zero operating frequency of last stage after completing one cycle)

F9.01 Programming operation time setting unit	Setting range:0, 1
-----------------------------------------------	--------------------

- 0: second
- 1: minute

F9.02 Stage timing T1	Setting range: 0.0~3600.0
F9.03 Stage timing T2	Setting range: 0.0~3600.0
F9.04 Stage timing T3	Setting range: 0.0~3600.0
F9.05 Stage timing T4	Setting range: 0.0~3600.0
F9.06 Stage timing T5	Setting range: 0.0~3600.0
F9.07 Stage timing T6	Setting range: 0.0~3600.0

F9.08	Stage timingT7	Setting range: 0.0~3600.0
F9.09	Stage timingT8	Setting range: 0.0~3600.0
F9.10	Stage timingT9	Setting range: 0.0~3600.0
F9.11	Stage timingT10	Setting range: 0.0~3600.0
F9.12	Stage timingT11	Setting range: 0.0~3600.0
F9.13	Stage timingT12	Setting range: 0.0~3600.0
F9.14	Stage timingT13	Setting range: 0.0~3600.0
F9.15	Stage timingT14	Setting range: 0.0~3600.0
F9.16	Stage timingT15	Setting range: 0.0~3600.0

parameters F9.02~F9.16 are used to set running time of each stage.

F9.17	T1 Running mode	Setting range: 0~7
F9.18	T2 Running mode	Setting range: 0~7
F9.19	T3 Running mode	Setting range: 0~7
F9.20	T4 Running mode	Setting range: 0~7
F9.21	T5 Running mode	Setting range: 0~7
F9.22	T6 Running mode	Setting range: 0~7
F9.23	T7 Running mode	Setting range: 0~7
F9.24	T8 Running mode	Setting range: 0~7
F9.25	T9 Running mode	Setting range: 0~7
F9.26	T10 Running mode	Setting range: 0~7
F9.27	T11 Running mode	Setting range: 0~7
F9.28	T12 Running mode	Setting range: 0~7
F9.29	T13 Running mode	Setting range: 0~7
F9.30	T14 Running mode	Setting range: 0~7
F9.31	T15 Running mode	Setting range: 0~7

F9.17~F9.31 are used to set operating direction and Acc time of each stage:

0 : Run forward Acc/Dec time is 1; 1 : Run forward Acc/Dec time is 2; 2 : Run forward Acc/Dec time is 3; 3 : Run forward Acc/Dec time is 4; 4 : Run reverse Acc/Dec time is 1; 5 : Run reverse Acc/Dec time is 2; 6 : Run reverse Acc/Dec time is 3; 7 : Run reverse Acc/Dec time is 4;

F9.32 Record function	Setting range:0~2
-----------------------	-------------------

0: Record function disabled

In the process of program running, press the stop key, the current program running counter value is not remembered, if the run command activated again, inverter will start from the first stage to run.

1: The memory function of program running is effective, will be saved after power off.

During the program run, the stop key acts as the Pause key for the program to run. If you re-enter the run command, continue from the break-point.

If the function code F9.00 is reset after stopping, the counter value of the current program will be eliminated.

2.The memory function of program running is effective, will not be saved after power off.

During the program run, the stop key acts as the Pause key for the program to run. If you re-enter the run command, continue from the break-point.

The break-point is saved after the inverter is out of power.

If the function code F9.00 is reset after stopping, the counter value of the current program will be eliminated.

FA PID parameter

FA parameter group defines parameters of PID control function.

PID control function diagram is shown below, where P is proportional gain, I is integration time, D is differential time.

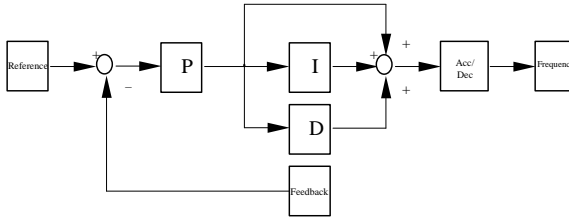

FA.00 PID control characteristic	Setting range: 0、1
----------------------------------	--------------------

0: Positive characteristic

The Motor speed is required to increases with the reference speed.

1: Negative characteristic

The motor speed is required to decrease when the reference value increases.

FA.01 reference selection	Setting range: 0、1、2、3
---------------------------	------------------------

0:Panel Digital setting

1: External analog signal AI1

2: External analog signal AI2

3:Rs-485 communication setting

FA.02 feedback channel selection	Setting range: 0、1
----------------------------------	--------------------

1: External analog signal AI1 (0~10V)

2: Analog signal AI2 (0~10V or 4~20mA)

FA.03 Digital setting of reference	Setting range: 0.00V~10.00V
------------------------------------	-----------------------------

Digital reference is set by UP/DOWN Keypad.

FA.04 Minimum reference	Setting range: 0.0~100.0%
FA.05 Maximum reference	Setting range: 0.0~150.0%
FA.06 Minimum feedback	Setting range: 0.0~100.0%
FA.07 Minimum feedback	Setting range: 0.0~150.0%

By setting parameter FA.04~FA.07, actual value of reference and feedback can be displayed accurately.

FA.08 Proportional gain	Setting range:0.0~10.00
FA.09 Integration time Ti	Setting range:0.00(no integration)~99.99s
FA.10 differential time Td	Setting range:0.00(no differentiation)~99.99s
FA.11 Sample cycle T	Setting range:0.00(do not specify T)~99.99s

Setup parameters of PID regulator

FA.12 Error limit	Setting range: 0.0~15.0% (corresponding to close loop input)
-------------------	--------------------------------------------------------------

Definition: relative error of close loop system = $\frac{|\text{input value} - \text{feedback value}|}{\text{input value}} \times 100\%$.

If relative error of close loop system is bigger than the setting value of error limit, then the PID regulator will adjust the error.

If relative error of close loop system is in the setting range of error limit, then stop PID regulating, PID regulator's output maintains constant.

FA.13 Level of abnormal feedback signal	Setting range: 0~100%
-----------------------------------------	-----------------------

This function code defines abnormal level of feedback signal.

Definition: Abnormal level = $\frac{|\text{reference} - \text{feedback}|}{\text{reference}} \times 100\%$

FA.14 Detection time of abnormal feedback signal	Setting range: 0~3600S
--------------------------------------------------	------------------------

This function code defines the detection time of abnormal feedback signal. When feedback signal exceeds abnormal level and hold time exceeds the detection time, action at abnormal signal (ER.06) will be executed. When this parameter is set to 0, the abnormal feedback signal detect function is disable.

FA.15 Reserved	
----------------	--

FA.16 PID Sleep control	Setting range: 0~2
-------------------------	--------------------

0: No sleep function;

1: Internal waking up, which is controlled by parameters FA.17~FA.20;

2: External input terminal, which is controlled by terminal function 26 (PID waking terminal), is

decided by parameter F6.02~F6.08.

FA.17 Delay time of sleeping	Setting range: 0.0~3600S
FA.18 Sleeping frequency	Setting range: 0.0~600.0Hz

FA.19 Delay time of waking	Setting range: 0.0~60S
FA.20 Waking value	Setting range: 0.0~100%actual value

For PID control, parameters FA.17~ FA.20 define delay time of sleeping, sleeping frequency, delay time of waking and waking value.

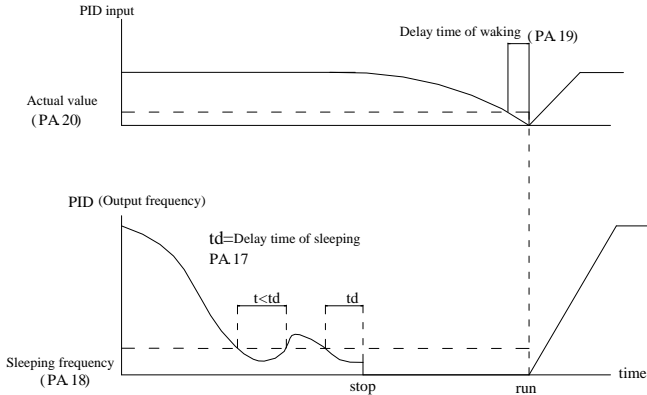

Fig. 6-30 PID sleeping and waking

FB Traverse function

FB.00 Traverse mode	Setting range: 0、 1
---------------------	---------------------

0: Auto mode

At first, the drive operates at preset frequency of traverse operation (FB.01) for certain time (FB.02), and then enter traverse mode automatically.

1: Manual mode

If the multi-function terminal (Dli is set to terminal function 20) is enabled, the drive will enter traverse mode. If the terminal is disabled, the drive will exit traverse operation and operate at the preset traverse frequency (FB.01).

FB.01 Preset traverse frequency	Setting range: 0.00~600.0Hz
FB.02 Hold time of preset traverse frequency	Setting range: 0.0~3600s

FB.01 defines drive's operating frequency before entering traverse operation. In auto mode, FB.02 defines the hold time of preset traverse frequency before traverse operation. In manual mode, FB.02 setting is invalid. refer to Fig. 6-31 for details.

FB.03 Preset central frequency	Setting range: 0.00~400.0 Hz
--------------------------------	------------------------------

Traverse operation is shown in Fig. 6-31.

FB.04 Travers amplitude	Setting range: 0.0~50%
-------------------------	------------------------

Travers amplitude = Preset central frequency×Fb.04

FB.05 Step frequency	Setting range: 0.0~50%
----------------------	------------------------

refer to Fig. 6-31. If it is set at 0, then there will be no step frequency.

FB.06 Traverse cycle	Setting range: 0.1~999.9S
----------------------	---------------------------

It defines the period of traverse operation including rising and falling time.

FB.07 Rise time of triangular wave	Setting range: 0.0~100.0%
------------------------------------	---------------------------

It defines the rising time (FB.06×FB.07 s) of traverse operation, and falling time (Fb.06×(1-Fb.07) s).

Please refer to Fig. 6-31.

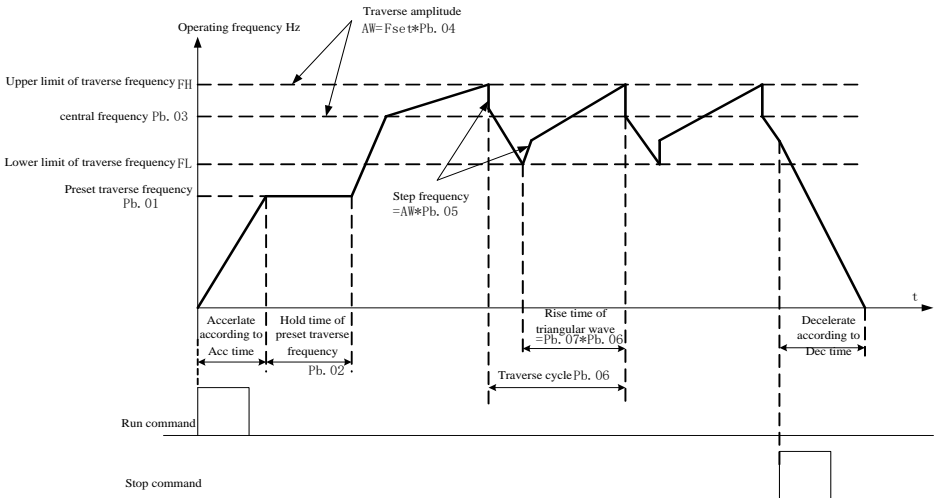

Fig. 6-31 Traverse operation

FC Communication and Bus control function

FC.00 Baud rate selection	Setting range: 0~5
---------------------------	--------------------

Select baud rate of serial communication

0:1200BPS 1:2400 BPS 2:4800 BPS 3:9600 BPS 4:19200 BPS5:38400 BPS

FC.01 Data Format	Setting range: 0~8
-------------------	--------------------

Data format of serial communication protocol:

- 0: 8,N,2 For RTU (MODBUS) (Default)
- 1: 8,E,1 For RTU (MODBUS)
- 2: 8,O,1 For RTU (MODBUS)
- 3: 7,N,2 For ASCII (MODBUS)
- 4: 7,E,1 For ASCII (MODBUS)
- 5: 7,O,1 For ASCII (MODBUS)
- 6: 8,N,1 free communication format
- 7: 8,E,1 free communication format
- 8: 8,O,1 free communication format
- 9: 8,N,2 For RTU (MODBUS) master model

FC.02 Local address	Setting range: 1~32
---------------------	---------------------

When the host is communicating with several inverters, inverter's address is defined in this function code.

FC.03 Communication timeout detect	Setting range: 0.0、0.1~100.0s
------------------------------------	-------------------------------

The setting value is 0:No communication overtime protection.

The setting value isn't 0, in RS485communication control mode, if the communication between the inverter and the host is still abnormal in the time defined by FC.03, ER05 fault is displayed and the inverter acts according to the setting value of FC.05.

FC.04 Response delay	Setting range: 0 ~1000ms
----------------------	--------------------------

Response delay refers to the time from the drivere ceiving and executing the command of the host to returning reply frame to the host.

FC.05 EEROM Store function	Setting range: 0、1
----------------------------	--------------------

0: The parameter is stored into EEROM in communication.

1: The parameter is not stored into EEROM in communication.

FD Faults and protection parameters

FD.00 Motor overload protection mode	Setting range: 0, 1, 2
--------------------------------------	------------------------

- 0: No protection
- 1: Common motor protection

Since cooling conditions of common motor deteriorates at low speed, please lower the motor's thermal protection threshold at this time.

- 2: Variable frequency motor protection

Since the variable frequency motor applies forced air-cooling, the protection parameters needn't be adjusted during low speed running.

FD.01 Motor overload protection factor	Setting range: 20.0%-150.0%
----------------------------------------	-----------------------------

Heat dissipation becomes worse at low frequency, and high temperature will reduce service life of the motor. Through setting threshold of the electronic thermal overload relay, overload current and current limit will be proportionally adjusted.

When motor capacity is lower than that of the drive, this function is used provide overheat protection for the motor.

When several motors are driven by the same variable speed drive, this function is disabled. When display readings reaches 100%, overload protection will be trigger.

FD.02 Over voltage stall selection	Setting range: 0,1
------------------------------------	--------------------

- Over voltage stall selection
- 0: Disabled; 1:Enabled

In inverter's Dec process, the actual motor speed may be higher than the output synchronized speed of the inverter due to the load inertia. At this time, the motor will peed the energy back to the inverter, resulting in the voltage rise on the inverter's DC bus. If no measures being taken, tripping will occur due to over voltage.

The over voltage stall protection function is that during the Dec running, the inverter detects thebus voltage and compares it with the stall over voltage point defined by FD.03. If the bus voltage exceeds the stall over-voltage point, the inverter will stop reducing its output frequency. When the detected bus voltage is lower than the point, the Dec running will be restored, as shown in Fig.6-32.

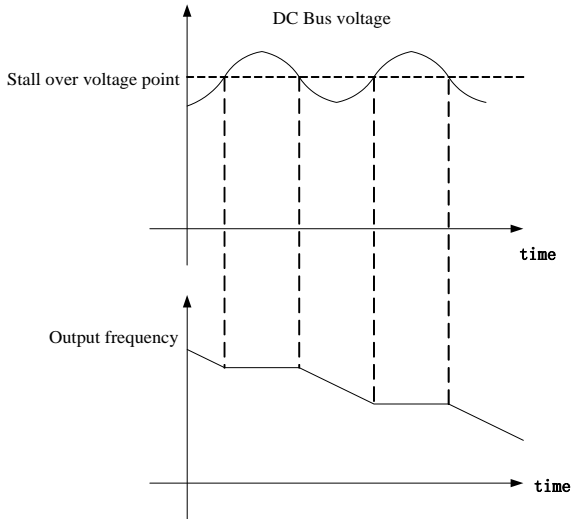

Fig. 6-32 Over voltage stall function

FD.03 Stall over voltage point	Setting range: 115.0%~150.0%
--------------------------------	------------------------------

Stall over voltage point = 115.0%~150.0% inverter's rated peak voltage

FD.04 Selection of overload pre-alarm detection	Setting range: 0, 1
-------------------------------------------------	---------------------

- 0:Overload is only monitored during constant speed operation, and alarms when overload occurs;
- 1:Overload is monitored all the time, and alarms when overload occurs;

FD.05 Overload detection threshold	Setting range: 20-180%
------------------------------------	------------------------

FD.06 Overload pre-alarm delay	Setting range: 0-60.0s
--------------------------------	------------------------

FD.05 defines the threshold value for overload alarm. It is a percentage of rated current.

FD.07 Auto current limiting threshold	Setting range: 20.0~150.0% (drive's rated output current)
---------------------------------------	-----------------------------------------------------------

FD.08 Frequency decrease rate during	Setting range: 0.00-99.99Hz/S
--------------------------------------	-------------------------------

FD.09 Action mode of auto current limiting	Setting range: 0, 1, 2
--------------------------------------------	------------------------

Auto current limiting function is used to limit the load current under the preset current (FD.07) in real time to avoid trip due to over-current. This function is especially useful for the applications of larger load inertia or sharp change of load.

FD.07 defines the threshold for current limiting. Its setting is a percentage of drive's rated current i.e.

FD.08 defines the decreasing rate of output frequency when the drive is in auto current limiting status. If FD.08 is set too small, overload fault may occur. If FD.08 is set too big, the drive may be in energy generation status for long time that may result in over-voltage protection.

The action mode of auto current limiting function is decided by FD.09:

FD.09= 0: disabled;

FD.09= 1: auto current limiting is effective during acceleration or deceleration but ineffective at constant speed;

FD.09= 2: auto current limiting is effective during acceleration/deceleration and constant speed;

FD.10 Auto reset	Setting range: 0~5
------------------	--------------------

0: disabled; 1~5: times of fault reset;

FD.11 Auto reset interval	Setting range: 2~20s
---------------------------	----------------------

When fault occurs, the drive stops output. After the time defined by FD.11, the drive resets fault automatically and continue running.

FD.10 defines the times of auto fault reset. If FD.10=0, auto reset function is disabled, and user can only reset fault in manual mode.

FD.12 Relay action in Auto reset	Setting range: 0、1
----------------------------------	--------------------

This parameter determine the relay action in auto reset period of the inverter.

0: no action

1: action

FD.13 Act selection at under-voltage fault	Setting range: 0、1、2
--------------------------------------------	----------------------

0: When under-voltage occurs, fault relay does not act, and fault code will not be saved.

1: When under-voltage occurs during running, fault relay acts and fault code will be saved. When under-voltage occurs during stop state, fault relay does not act, and fault code will not be saved.

2: When under-voltage occurs in running or stopping state, fault relay acts and fault code will be saved.

FD.14 Reserved	Reserved
FD.15 Reserved	Reserved
FD.16 Under-voltage point	380V voltage level Setting range: 250~440 220V voltage level Setting range: 200~260

380V voltage level :default value is 400v(DC voltage).

220V voltage level :default value is 250v(DC voltage).

In some case when the input voltage is low or not stable, the value can be adjusted to avoid under voltage fault.

FE Factory reserved

FE.00 Keyboard frequency setting lock function	Setting range: 0~1
------------------------------------------------	--------------------

0: Keyboard frequency settings are not locked, you can change the frequency of the inverter settings by keyboard keys;

1: The keyboard frequency setting lock can not change the frequency setting frequency of the inverter through the keyboard up and down key, and can only change the frequency setting frequency of the inverter by changing the F0.11

FE.01 Terminal start delay	Setting range: 0.0~20.0s
----------------------------	--------------------------

Used to set the setting Di terminal from breaking to the closed state changes, the frequency inverter for the delay time of the change

FE.02 Terminal stop delay	Setting range: 0.0~20.0s
---------------------------	--------------------------

Used to set the di terminal from the closed to the broken state changes, the frequency inverter for the delay time of the change

FE.03 MUDBUS respond	Setting range: 0~1
----------------------	--------------------

0: MODBUS protocol response write command

1: MODBUS protocol does not respond to the write command

FE.04 Acceleration and deceleration time switching frequency	Setting range: 0.00~600.00Hz
--------------------------------------------------------------	------------------------------

When the deceleration time switching frequency is 0, according to the 1 inverter deceleration time operation, deceleration time switching frequency is not 0, when the operation frequency is less than FE.04, according to the first deceleration time operation, when the operation frequency is greater than FE.04, in accordance with the second plus deceleration time operation.

FF Factory reserved

FF.00~FF.19 are reserved parameters for individual consumer.

FH Display function

FH.00 running display parameters selection	Setting range: 0~14
--------------------------------------------	---------------------

SINUS MINI drive has 15 state parameters in running state. User can scroll through them by pressing

▶▶ key during running process. Function code FH.00 defines the default display parameter after starting, which includes:

- 0: Frequency setting
- 1: Running frequency
- 2: Output current
- 3: Output voltage
- 4: Bus voltage
- 5: Overload rate
- 6: Preset line speed
- 7: Running line speed
- 8: Output torque
- 9: PI reference
- 10:PI feedback
- 11:Reserved
- 12:Analog input AI1
- 13:Analog input AI2
- 14:I/O status(0~511)

Input/output IO status correspond as blow:

relay1	Y1	reserved	reserved	DI5	DI4	DI3	DI2	DI1
Bit8	Bit7	Bit6	Bit5	Bit4	Bit3	Bit2	Bit1	Bit0

FH.01 Display parameters at stop	Setting range: 0~8
----------------------------------	--------------------

SINUS MINI drive has 9 state parameters in stopping state. User can scroll through them by pressing

▶▶ key during stop state.

Function code FH.01 defines the default display parameter upon power on, which includes:

- 0: Frequency setting
- 1: Preset line speed
- 2: DC Bus voltage

- 3: Reserved
- 4: Analog input AI1
- 5: Analog input AI2
- 6: I/O status
- 7: external counting value
- 8: PI reference
- 9: PI feedback

FH.02 Line speed factor	Setting range: 0.1~100
-------------------------	------------------------

When line speed is displayed, line speed = Output frequency × Line speed factor

FH.03 Inverter power	
----------------------	--

Display inverter power

FH.04 IPM heat sink temperature 1	Setting range: 0~100℃
FH.05 IPM heat sink temperature2	Setting range: 0~100℃

Display IPM heat sink temperature.

Note: some models have this function

FH.06 1st fault type	Setting range:
FH.07 2nd fault type	Setting range:
FH.08 3rd fault type	Setting range:

FH.06~FH.08 are used for memorizing the latest three fault types, and can record the voltage, current, frequency and terminal state at the last fault (in FH.09~FH.13) for checking.

Please refer to Chapter 7 for fault descriptions.

FH.09 Bus voltage at last fault (V)	Setting range: 0~999
FH.10 Output current at last fault (A)	Setting range: 0~999.9
FH.11 Frequency setting at last fault (Hz)	Setting range: 0~400.0
FH.12 Running frequency at last fault (Hz)	Setting range: 0~400.0
FH.13 I/O state at last fault	Setting range: 0~511
FH.14 Total operating time	Setting range: 0~9999
FH.15 Software version	Setting range: 0~9.99
FH.16 Keyboard Software version	Setting range: 0~9.99

FH.13 At last time, I/O Status correspond as blow:

relay1	Y1	reserved	reserved	DI5	DI4	DI3	DI2	DI1
Bit8	Bit7	Bit6	Bit5	Bit4	Bit3	Bit2	Bit1	Bit0

Chapter 7 Fault diagnosis and troubleshooting

7.1 Fault query at fault

If control power supply is normal at fault, the drive will be in fault displaying status all the times. At this time, user can enter parameter group FH to get related information about the failure, such as output frequency, frequency setting, output current, rotating direction, operating condition, and the 3 latest faults, which is shown in the table below.

Fault code	Display content	Description
FH.06	Fault code	1st fault type
FH.07		2nd fault type
FH.08		3rd fault type
FH.09	Date (With unit)	Bus voltage at last fault
FH.10		Output current at last fault
FH.11		Frequency setting at last fault
FH.12		Running frequency at last fault
FH.13		I/O terminal's state at last fault

7.2 List of Fault and Alarm Information

SINUS MINI serial inverter is equipped with complete protection functions to provide efficient protection while utilizing its performance sufficiently. Some failure instructions may be displayed during operation. compare the instructions with the following table and analyze, decide the causes and solve failures.

For damages on units or questions that can't be resolved, please contact with local distributors/agents, service centers or manufacturer for solutions.

Failure No	Failure code	Failure description	Potential causes	Solutions
1	oc1	Over current protection when acceleration operation	Low grid voltage	Check input power supply
			Start-up too fast during motor operation	Restart after the motor stops rotating
			Rotating inertial of load is very large and shock load is very heavy	Increase the acceleration time and reduce the occurrences of sudden change of load
			Improper setting of motor parameters	Set motor parameters properly
			Set start-up frequency too high	Decrease start-up frequency
			Acceleration time is too short	Lengthen acceleration time
			Set V/F curve ratio too large	Adjust V/F curve setting and torque boost
2	oc2	Over current protection when deceleration operation	Low grid voltage	Check input power supply
			Rotating inertial of load is too large	Choose appropriate energy braking components
			Improper setting of motor parameters	Set motor parameters properly
			Deceleration time is too short	Lengthen deceleration time
			Power level of inverter is small	Replace to inverter with proper model
3	oc3	Over current protection when operation with constant speed	Sudden change of load during operation	Decrease load's abrupt frequency change and amplitude
			Improper setting of motor parameters	Set motor parameters properly
			Power level of inverter is small	Replace to inverter with proper model
4	occ1	IGBT module protection in Acc process	Low grid voltage	Check input power supply
			Start-up too fast during motor operation	Restart after the motor stops rotating
			Rotating inertial of load is very large and shock load is very heavy	Increase the acceleration time and reduce the occurrences of sudden change of load
			Improper setting of motor parameters	Set motor parameters properly
			Set start-up frequency too high	Decrease start-up frequency
			Acceleration time is too short	Lengthen acceleration time
			Set V/F curve ratio too large	Adjust V/F curve setting and torque boost
			Power level of inverter is small	Replace with inverter with proper model

Failure No	Failure code	Failure description	Potential causes	Solutions
5	occ2	IGBT module protection in Dec process	Low grid voltage	Check input power supply
			Rotating inertial of load is too large	Choose appropriate energy braking components
			Improper setting of motor parameters	Set motor parameters properly
			Deceleration time is too short	Lengthen deceleration time
			Power level of inverter is small	Replace to inverter with proper model
6	occ3	IGBT module protection in constant speed process	Sudden change of load during operation	Decrease load's abrupt frequency change and amplitude
			Improper setting of motor parameters	Set motor parameters properly
			Power level of inverter is small	Replace to inverter with proper model
10	ou1	Over voltage protection when acceleration operation	Motor short to ground	Check motor wiring
			Abnormal input power supply voltage	Check input power supply
			Fast start-up again when motor operates with high speed	Start again after the motor stop rotating
11	ou2	Over voltage protection when deceleration operation	Motor short to ground	Check motor wiring
			Rotating inertial of load is too large	Choose appropriate energy braking components
			Deceleration time is too short	Lengthen deceleration time
12	ou3	Over voltage protection when operation with constant speed	Motor short to ground	Check motor wiring
			Abnormal input power supply	Check input power supply
15	oH2	Heat sink 2 over temperature protection	Ambient over-temperature	Lower the ambient temperature and strengthen ventilation and radiation.
			Blockage of air duct	Clean the dusts, wool and other foreign objects in the air duct.
			Fan failure	Check whether fan wirings are well connected. Replace a new fan of the same model.
			Inverter module failure	Seek for technical support
			Temperature detection circuit failure	Seek for technical support
16	LU	Power under voltage	The power voltage is lower than the minimum operating voltage of the equipment	Check input power supply
			The internal power source of the inverter is abnormal	Seek for technical support
17	oH1	Heat sink 1 over temperature protection	Ambient over-temperature	Lower the ambient temperature and strengthen ventilation and radiation.
			Blockage of air duct	Clean the dusts, wools and other foreign objects in the air duct.
			Fan failure	Check whether fan wirings are well connected. Replace a new fan of the same model.

Failure No	Failure code	Failure description	Potential causes	Solutions
			Inverter module failure	Seek for technical support
			Temperature detection circuit failure	Seek for technical support
18	oL1	Inverter overload protection	Input power under voltage	Check input power supply
			Fast start-up when motor operates with high speed	Start again after the motor stop rotating
			Keep overloading for a long period of time	Shorten the overloading time and reduce load
			Acceleration and deceleration time is too short	Prolong the acceleration/deceleration time
			V/F curve ratio is set too large	Adjust V/F curve setting and torque boost
			Power level of inverter is small	Replace to inverter with proper model
19	oL2	Motor overload protection	Input power under voltage	Check input power supply
			Motor rotation is blocked or load mutation occurs	Prevent the motor rotation from blocking and reduce the load mutation
			Common motor maintains running under heavy load for a long period of time	Replace the common motor with variable frequency motor or improve the running frequency
			Motor overload protection time is set too small	Increase the motor overload protection time
			V/F curve ratio is set too large	Adjust V/F curve setting and torque increment
			DC braking current is set too high	Reduce the DC brake current
20	LP	Input power failure	There is abnormal connection, missing connection or disconnection at the power terminal of the inverter	Check the power connections as per the operational regulations and eliminate the errors of missing connection and disconnection
21	SP	Abnormal output phase loss	There is abnormal connection, missing connection or disconnection at the output side of the inverter	Check the power connections at the output side of the inverter as per the operational regulations and eliminate the errors of missing connection and disconnection
22	ER01	EEPROM failure	EEPROM reading and writing failure	Seek for technical support
23	ER02	CPU failure	CPU failure	Seek for technical support
24	ER03	Keypad communication fault	Keypad or its control line failure;	Check the connection of Keypad and its control line.
			CPU failure	Seek for technical support
25	ER04	parameter setting failure	In traverse or three-wire operation mode, wrong parameter setting	Modify parameter setting
26	ER05	Communication abnormal 2 (Terminal 485)	The communication of terminal 485 is disconnected	Check the connection of the equipment communications
			The baud rate is set improperly	Set compatible baud rate

Failure No	Failure code	Failure description	Potential causes	Solutions
			The communication of terminal 485 is faulty	Check whether the data receiving and transmission complies with the protocol, whether the check sum is correct and whether the receiving and transmission interval complies with the requirements
			The communication of terminal 485 is time-out	Check whether the communication time-out is set properly and confirm the communication cycle of the application program
			The failure alarm parameter is set improperly	Adjust the failure alarm parameter
27	ER06	Analog close loop feedback failure	Improper setting of FA parameter group;	Modify setting of FA parameter group;
		Analog close loop feedback failure	feedback signal lost	. Check feedback signal.
28	ER07	Tuning error	Improper setting of motor parameters;	Re-set the motor's rated parameters;
			Significant deviation of parameters obtained after tuning comparing with the standard parameters;	Execute motor auto-tuning again under zero load condition.
30	ER09	Current detection failure	Current sensor failure and bad contact	Check the current sensor
32	END	Trial period is outdated	Contact your supplier	Contact your supplier
33	ER12	External fault	Act trigger by external fault	Check external device according external fault signal
34	OL	Overload pre-alarm	1. refer to OL1 and OL2; 2. Improper setting of FD.04~FD.06	1. refer to OL1 and OL2; 2. Modify setting of FD.04~FD.06

7.3 Troubleshooting Procedures

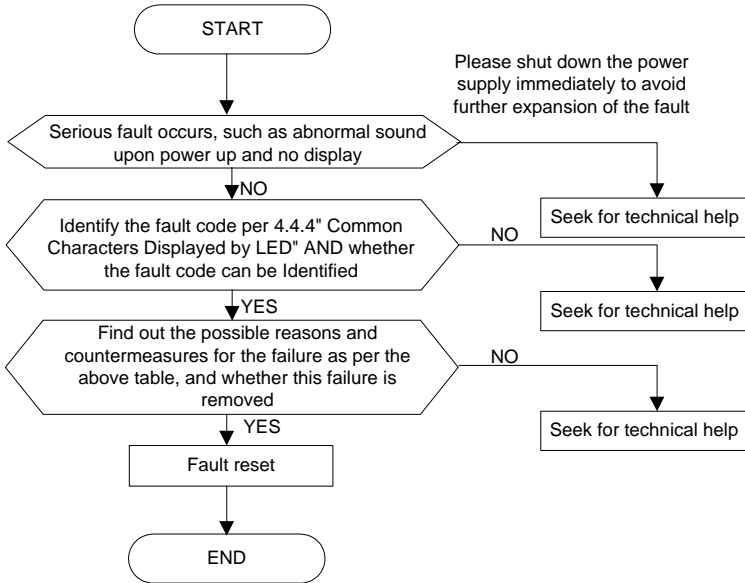

Chapter 8 Routine Repair and Maintenance

The application environment (such as temperature, humidity, dust and powder, wool, smoke and oscillation), burning and wearing of internal devices and other factors may increase the possibilities of inverter failure. To reduce the failures and prolong the service life the inverter, it needs to conduct routine repair and periodic maintenance.



Note

1. Only the personnel receiving professional training can dismantle and replace the inverter components.
2. Prior to inspection and maintenance, please make sure that the power supply to the inverter has been shut down for at least ten minutes or the CHARGER indicator is OFF, or there may be risks of electric shock
3. Do not leave metal components and parts in the inverter, or it may damage the equipment.

8.1 Routine Maintenance

The inverter shall be used under the allowable conditions as recommended in this manual and its routine maintenance shall be conducted as per the table below.

Item	Inspection Contents	Inspection Means	Criteria
Operating Environment	Temperature	Thermometer	-10 ~ +40°C Derated at 40 to 50°C, and the rated output current shall be decreased by 1% for every temperature rise of 1°C.
	Humidity	Humidometer	5 ~ 95%, no condensing
	Dust, oil, water and drop	Visual check	There are no dust, oil, water and drop.
	Vibration	Special test instrument	3.5mm, 2~ 9Hz; 10m/s ² , 9~ 200Hz; 15m/s ² , 200~ 500Hz
	Gas	Special test instrument, smell check and visual check	There are no abnormal smell and smoke.
Inverter	Overheat	Special test instrument	Exhaust normal
	Sound	Listen	There is no abnormal sound.
	Gas	Smell and visual check	There are no abnormal smell and smoke.
	physical appearance	Visual check	The physical appearance is kept intact.
	Heat sink fan ventilation	Visual check	There are no fouling and wool that block the air duct.
	Input current	Ampere-meter	In the allowable operating range. refer to the nameplate.
	Input voltage	Voltmeter	In the allowable operating range. refer to the nameplate.
	Output current	Ampere-meter	In the rated value range. It can be overloaded for a short while.
Output voltage	Voltmeter	In the rated value range.	
Motor	Overheat	Special test instrument and smell.	There are no overheat fault and burning smell.
	Sound	Listen	There is no abnormal sound.
	Vibration	Special test instrument	There is no abnormal oscillation.

8.2 Periodic Maintenance

It needs to perform periodic inspection on the inverter once every three to six months according to the application environment and work conditions.

Item	Inspection Contents	Inspection Means	Criteria
Inverter	Main circuit terminal	Screwdriver/sleeve	The screws are tightened and the cables are kept well.
	PE terminal	Screwdriver/sleeve	The screws are tightened and the cables are kept well.
	Control circuit terminal	Screwdriver	The screws are tightened and the cables are kept well.
	Reliability of internal connections and connectors	Screwdriver and hands	Connection is firm and reliable.
	Expansion card connector	Screwdriver and hands	Connection is firm and reliable.
	Mounting screws	Screwdriver/sleeve	The screws are tightened.
	Cleaning the dusts and powders	Cleaner	There are no dusts and wools.
	Internal foreign objects	Visual check	There are no foreign objects.
Motor	Insulation test	500VDC mega-meter	Normal

8.3 Component Replacement

different types of components have different service lives. The service lives of the components are subject to the environment and application conditions. Better working environment may prolong the service lives of the components. The cooling fan and electrolytic capacitor are vulnerable components and shall be conducted routine inspection as per the table below. If any fault occurs, please conduct immediate replacement.

Vulnerable Components	Damage Causes	Solutions	Items for Routine Inspection
Fan	Bearing wear, blade aging	Change	The fan blade has no cracks and rotates normally. The screws are tightened.
Electrolytic capacitor	Ambient temperature is relatively high and electrolyte volatilizes.	Change	There are no electrolyte leakage, color change, crack and shell inflation. The safety valve is normal. Static capacity is equal to or higher than the initial value times 0.85.



Note

When the inverter is stored for a long period of time, power connection test shall be conducted once within two years and last at least five hours. It can use voltage regulator to gradually increase the value to the rated value when power connection is performed.

8.4 Insulation Test

Since the inverter has undergone insulation test upon its ex-factory, the user shall not perform such test as much as possible under general condition. If the test is unavoidable, please perform the test strictly according to the following procedures, or it may damage the inverter.

It shall perform dielectric test strictly, or it may damage the inverter. If the dielectric test is unavoidable, please contact our company.

■ Main Circuit Insulation Test

- ◆ Utilize 500VDC megameter to perform test under condition of main power shutdown;
- ◆ The main circuit terminal shall be connected with public conducting wires;
- ◆

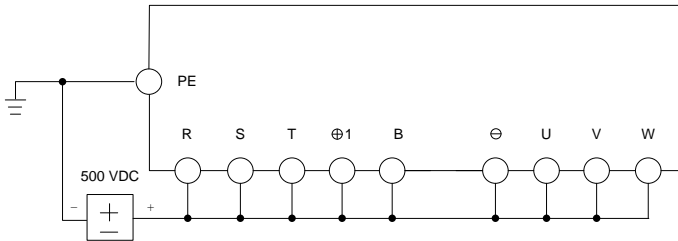

Fig:8-1 Main Circuit Insulation Test for

SINUS MINI-0001 2S~SINUS MINI-0004 2S 、 SINUS MINI-0002 4T~SINUS MINI-0006 4T

Appendix A Communication Protocol

1. Application range

Universal Variable Speed Drive connects with PLC or host computer via RS485 bus, which adopts single master and multi-slave network structure.

2. physical description

Interface: RS485 Bus, asynchronous, half-duplex

Each segment on the network bus can have up to 32 stations.

2.1. Data format

- 0: 8,N,2 for RTU (MODBUS) (Default)
- 1: 8,E,1 for RTU (MODBUS)
- 2: 8,O,1 for RTU (MODBUS)
- 3: 7,N,2 for ASCII (MODBUS)
- 4: 7,E,1 for ASCII (MODBUS)
- 5: 7,O,1 for ASCII (MODBUS)
- 6: 8,N,1 free communication format
- 7: 8,E,1 free communication format
- 8: 8,O,1 free communication format

2.2. Baud rate

Available baud rate: 1200, 2400, 4800, 9600, 19200, 38400

The default value is 9600BPS.

2.3. Communication address

Slave address range: 1~32

2.4. Communication mode

The drive works as slave, and PLC or host computer works as master. Communication of master is polling, and the slave is in response mode.

2.5 Main function

a. Operation control:

Run, Stop, Jog start, Jog stop, free run to stop, Dec to Stop, fault reset, etc.

b. Operation monitor:

Running frequency, frequency setting, output voltage, output current, close loop feedback, close loop reference, etc.

c. Operation of function code:

Read and write value of function code, which includes:

Present running frequency, present frequency setting, output voltage, current, close loop feedback, close loop reference, etc.

3.Free communication Protocol

3. 1 Data:

Character format:8, N, 1, 8 bit data, one bit stop, no parity

8. E, 1, 8 bit data, one bit stop, Even parity

8. O, 1, 8 bit data, one bit stop, Odd parity

1. A message from computer to inverter

BYT E0	BYT E1	BYT E2	BYT E3	BYT E4	BYT E5	BYT E6	BYT E7	BYT E8	BYT E9	BYT E10
HD	AD	CD	OP	DT		CON		ED	SUM	

Item	Byte Name	Detail
HD	Start byte	02H, one byte
AD	address	Inverter address, one byte, 0 is broadcast address
CD	parameter R/W command	One byte 0h: no operation 1h: read parameter from the inverter 10h: write parameter from the inverter, not store into EEROM 11h: write parameter from the inverter, store into EEROM
OP	parameter number	parameter number, two bytes, BYTE3 is lower byte, BYTE4 is higher byte
DT	parameter value	parameter value, two bytes, BYTE5 is lower byte, BYTE6 is higher byte

CON	Control word	Command word, two bytes, BYTE7 is lower byte, BYTE8 is higher byte Bits of BYTE7 are defined as following: bit0 =1, run command =0, no command bit1 =1, forward =0, reverse bit2 =1, forward jog start =0, forward jog stop bit3 =1, reverse jog start =0, reverse jog stop bit4 0-» 1, Fault reset command bit5 reserved bit6 =1, free stop command =0, no command bit7 =1, decrease stop command =0, no command BYTE8 reserved
ED	End byte	A0H, one byte
SUM	Xor check	Xor form BYTE1 to BYTE9

2. A message from the inverter to the computer

BYT E0	BYT E1	BYT E2	BYT E3	BYT E4	BYT E5	BYT E6	BYT E7	BYT E8	BYT E9	BYT E10
HD	AD	CT	OP	DT	ST	ED	SUM			

Item	Byte name	Detail
HD	Start byte	02H, one byte
IN	address	Inverter address, one byte, 0 is broadcast address
CT	parameter operation status	One bye 0: success 1: data received is exceed the range 2: address is exceed the range 3: data can not be modified while inverter is running 4: data is read only, can not be modified
OP	parameter number	parameter number, two bytes, BYTE3 is lower byte, BYTE4 is higher byte

DT	parameter value	parameter value, two bytes, BYTE5 is lower byte, BYTE6 is higher byte
ST	Status word	Status word of the inverter, two bytes, BYTE7 is lower byte, BYTE8 is higher byte. Bits of BYTE7 are defined as following: bit0 =1, forward run =0, reverse run bit1 =1, inverter fault =0, inverter no fault bit2 =1, inverter running =0, inverter stop bit3 =1, data valid =0, data invalid bit4 =1, RS485 frequency setting =0, local frequency setting BYTE8 is the error code
ED	End byte	A0H, one byte
SUM	Xor check	Xor form BYTE1 to BYTE9

3. 2 Application note

1. The OP,DT,ST,CON in communication protocol are two bytes. The address calculation of OP is converting the parameter address of the parameter list to HEX value. For example, 270 parameter, convert to 10E in hex format; the lower byte of OP is 0eh;the higher byte of OP is 01h. Other parameters that are not listed in parameter table are as following table.

1000H	Status word	1001H	Errorcode	1002 H	Control word
1003H	Frequency setting	1004H	Running frequency	1005H	Output current
1006H	Output voltage	1007H	DC bus voltage	1008H	Overload rate
1009H	Preset line speed	100AH	Running line speed	100BH	Output torque
100CH	PI reference	100DH	PI feedback	100EH	reserved
100FH	Analog input AI1	1010H	Analog input AI2	1011H	I/O status
1012H	External counting value	1013H	PID Set		

2. For example, the computer set the set frequency of the inverter to 50.00Hz and send the run command to the inverter. The address of the inverter is 01h. The OP of the setting frequency is 1003h in hex format. The Setting frequency 50.00(5000) is converted to 1388h in hex format.

A message from computer to the inverter:

02H	01H	10H	03H	10H	88H	13H	03H	00H	A0H	3AH
-----	-----	-----	-----	-----	-----	-----	-----	-----	-----	-----

The inverter response:

02H	01H	00H	03H	10H	88H	13H	1DH	00H	A0H	34H
-----	-----	-----	-----	-----	-----	-----	-----	-----	-----	-----

3. 3 Fault and troubleshooting

1. The protocol provide Start byte, end byte , xor check means to ensure the correctness of the communication.
2. There must be two bytes interval between two message.
3. After the host issue a message, if the inverter does not response in seven bytes interval, the over time fault of communication takes place.

4. MODBUS Protocol

4.1 Character format

1. ASCII

Communication adopts hexadecimal system, and the valid ASCII characters are: "0"... "9", "A"... "F", which is expressed in hexadecimal format. Such as:

ASCII character: '0' '1' '2' '3' '4' '5' '6' '7' '8' '9' 'A' 'B' 'C' 'D' 'E' 'F'

ASCII code (Hex): 30H 31H 32H 33H 34H 35H 36H 37H 38H 39H 41H 42H 43H 44H 45H 46H

7,N,2

start	0	1	2	3	4	5	6	stop	stop
-------	---	---	---	---	---	---	---	------	------

7,E,1

start	0	1	2	3	4	5	6	even	stop
-------	---	---	---	---	---	---	---	------	------

7,O,1

start	0	1	2	3	4	5	6	odd	stop
-------	---	---	---	---	---	---	---	-----	------

2. RTU

8,N,2

start	0	1	2	3	4	5	6	7	stop	stop
-------	---	---	---	---	---	---	---	---	------	------

8,E,1

start	0	1	2	3	4	5	6	7	even	stop
--------------	----------	----------	----------	----------	----------	----------	----------	----------	-------------	-------------

8,0,1

start	0	1	2	3	4	5	6	7	odd	stop
--------------	----------	----------	----------	----------	----------	----------	----------	----------	------------	-------------

4.2 Function code

Function code	Description
03H	Read data
06H	Modify data
08H	Loop detection

2. Function code description

RTU

(1) Read data

Frame head and frame tail are used to ensure input time (without any information) larger than 10ms.

Each time, reading data should be less than 30 bytes.

Message format of master request:

Slave address	Function code	Start address of data		Data quantity (Unit: word)		Redundancy check	
		MSB	LSB	MSB	LSB	LSB	MSB
1 byte	03H	MSB	LSB	MSB	LSB	LSB	MSB

Message format of slave response:

Slave address	Function code	Data quantity	Data 1		...	Data n		Redundancy check	
			MSB	LSB		MSB	LSB	LSB	MSB
1 byte	03H	1 byte	MSB	LSB	...	MSB	LSB	LSB	MSB

MSB: high byte of double byte number; LSB: low byte of double byte number.

(2) Modify data

Message format of master request:

Slave address	Function code	Start address of data		Modified value		Redundancy check	
		MSB	LSB	MSB	LSB	LSB	MSB
1 byte	06H	MSB	LSB	MSB	LSB	LSB	MSB

Message format of slave response:

Slave address	Function code	Start address of data		Modified value		Redundancy check	
1 byte	06H	MSB	LSB	MSB	LSB	LSB	MSB

(3) Loop detection

The command is used to test whether communication between main control equipment (usually PC or PLC) and the drive is normal. After receiving data content, the drive will return it to main control equipment without any modifying.

ASCII:

(1) Read data:

Reading data should be less than 30 bytes at a time.

Message format of master request:

Frame head	Slave address		Function code		Data address				Data quantity				LRC		Frame tail	
‘:’	MSB	LSB	‘0’	‘3’	4	3	2	1	4	3	2	1	MSB	LSB	CR	LF

Message format of slave response:

Frame head	Slave address		Function code		Data address				Data quantity				LRC		Frame tail	
‘:’	MSB	LSB	‘0’	‘3’	4	3	2	1	4	3	2	1	MSB	LSB	CR	LF

(2) Modify data:

Message format of master request:

Frame head	Slave address		Function code		Data address				Modified value				LRC		Frame tail	
‘:’	MSB	LSB	‘0’	‘6’	4	3	2	1	4	3	2	1	MSB	LSB	CR	LF

Message format of slave response:

Frame head	Slave address		Function code		Data address				Modified value				LRC		Frame tail	
‘:’	MSB	LSB	‘0’	‘6’	4	3	2	1	4	3	2	1	MSB	LSB	CR	LF

3. Examples

(1) Function code 03H: Read parameter data

ASCII mode:

Format of query message:

Format of response message:

Starting character	':'
Slave address	'0'
	'1'
Function code	'0'
	'3'
Data address	'0'
	'2'
	'0'
	'0'
Data quantity (word)	'0'
	'0'
	'0'
	'1'
LRC	'F'
	'9'
END	CR
	LF

Starting character	':'
Slave address	'0'
	'1'
Function code	'0'
	'3'
Data address	'0'
	'0'
	'0'
	'2'
Data content	'1'
	'5'
	'5'
	'9'
LRC	'8'
	'C'
END	CR
	LF

RTU mode: Format of query message:

Format of response message:

Slave address	01H
Function code	03H
Data address	02H
	00H
Data quantity (Word)	00H
	01H
Low byte CRC	85H
High byte CRC	B2H

Slave address	01H
Function code	03H
Data address	00H
	02H
Data content	15H
	59H
Low byte CRC	2AH
High byte CRC	A0H

(2) Function code 06H: Write parameter data

ASCII mode:

Format of query message:

Format of response message:

Starting character	'.'
Slave address	'0'
	'1'
Function code	'0'
	'6'
Data address	'0'
	'1'
	'0'
	'0'
Modified value	'1'
	'7'
	'7'
	'0'
LRC	'7'
	'1'
END	CR
	LF

Starting character	'.'
Slave address	'0'
	'1'
Function code	'0'
	'6'
Data address	'0'
	'1'
	'0'
	'0'
Modified value	'1'
	'7'
	'7'
	'0'
LRC	'7'
	'1'
END	CR
	LF

RTU mode:

Format of query message:

Format of response message:

Slave address	01H
Function code	06H
Data address	01H
	00H
Modified value	17H
	70H
Low byte CRC	86H
High byte CRC	22H

Slave address	01H
Function code	06H
Data address	01H
	00H
Modified value	17H
	70H
Low byte CRC	86H
High byte CRC	22H

(3) Function code 08H: loop detection

ASCII mode:

Format of query message:

Format of response message:

Starting character	':'
Slave address	'0'
	'1'
Function code	'0'
	'8'
Sub-function code	'0'
	'0'
	'0'
	'0'
Data content	'1'
	'2'
	'A'
	'B'
LRC	'3'
	'A'
END	CR
	LF

Starting character	':'
Slave address	'0'
	'1'
Function code	'0'
	'8'
Sub-function code	'0'
	'0'
	'0'
	'0'
Data content	'1'
	'2'
	'A'
	'B'
LRC	'3'
	'A'
END	CR
	LF

RTU mode:

Format of query message:

Format of response message:

Slave address	01H
Function code	08H
Sub-function code	00H
	00H
Data content	12H
	ABH
Low byte CRC	ADH
High byte CRC	14H

Slave address	01H
Function code	08H
Sub-function code	00H
	00H
Data content	12H
	ABH
Low byte CRC	ADH
High byte CRC	14H

4.4 Control word and status word

1. Information of status word (2 bytes)(1000H)

Bit0	=1, FWD
	=0, REV
Bit1	=1, Drive failure
	=0, No drive failure
Bit2	=1, Running state
	=0, Stopping state
Bit3	=1, Modifying parameter valid
	=0, Modifying parameter invalid
Bit4	=1, Frequency setting via RS485
	=0, Local frequency setting
Bit5	=1, RS485 running control
	=0, Local running control

2. Information of status word (2 bytes) (1002H)

Bit0	=1, Running command
	=0, No running command
Bit1	=1, FWD
	=0, REV
Bit2	=1, Jog FWD
	=0, Jog FWD and stop
Bit3	=1, Jog REV
	=0, Jog REV and stop
Bit4	=1, Fault reset command
	=0, No fault reset command
Bit5	=1, Dec to stop command
	=0, No Dec to stop command
Bit6	=1, Free run to stop
	=0, No free run to stop
Bit7—bit15	Reserved

3. parameter address

Address	Name	Address	Name	Address	Name
1000H	Status word	1001H	Error code	1002 H	Control word
1003H	Frequency setting	1004H	Running frequency	1005H	Output current
1006H	Output voltage	1007H	DC bus voltage	1008H	Overload rate
1009H	Preset line speed	100AH	Running line speed	100BH	Output torque
100CH	PI reference	100DH	PI feedback	100EH	reserved
100FH	Analog input AI1	1010H	Analog input AI2	1011H	I/O status
1012H	External counting value	1013H	PID closed loop set point		

4.5 Fault and troubleshooting

If communication fault occurs, the drive will response fault code, and report function code or 80H to the main control equipment.

For example:

ASCII mode:

Starting character	‘.’
Slave address	‘0’
	‘1’
Function code	‘8’
	‘6’
Fault code	‘0’
	‘2’
LRC	‘7’
	‘7’
End character	CR
	LF

RTU mode:

Slave address	01H
Function code	86H
Fault code	02H
Low byte CRC	C3H
High byte CRC	A1H

Fault code:

01 Function code error:

Function code is invalid. In the protocol, valid function codes are: 03H, 06H or 08H.

02 Invalid data address:

Data address is invalid

- 03 Invalid data setting
Data value is invalid.
- 04 Invalid command:
In current state, the drive can not execute this command.
- 09 Wrong CRC check
- 11 Reserved
- 12 Message characters of the command string is too short
- 13 Command string is too long, and reading string should be less than 72 characters.
- 14 Contains non-ASCII character, non-starting character or non-CR, LF end character.

Additional information

1. Function code conversion

If preset data is n, then sending data $n = n \times (1/\text{increment})$ (refer to function parameters table)

Convert data “n” into HEX number, which is 2 bytes.

2. ASCII mode LRC check

In the example above, LRC check: $01H+03H+02H+00H+00H+01H=07H$, and it's complement=F9H.

3. RTU mode CRC check

LRC check is executed from slave address to data end character, and the operation rule is shown as following:

Step 1: Load a 16-bit register with FFFFH. Call this the CRC register;

Step 2: Execute XOR operation with the first message command and the lower byte of 16-bit CRC register, and put the result in the CRC register;

Step 3: Shift the CRC register one bit to the right (toward the LSB), and fill the MSB with 0;

Step 4: If the shifted bit is 0, save the new value of step 3 to CRC register; otherwise, execute XOR operation with A001H and CRC register, and save the result in CRC register;

Step 5: Repeat step3~4 until 8 shifts have been performed.

Step 6: Repeat step3~5 for the next 8-bit message command. Continue doing this until all messages have been processed. The final content of CRC register is the CRC value.

Note: When the 16-bit CRC is transmitted in the message, the low-order byte will be transmitted first, followed by the high-order byte.

Appendix B Control Mode Setting Process

- ◆ A inverter connected to a computer

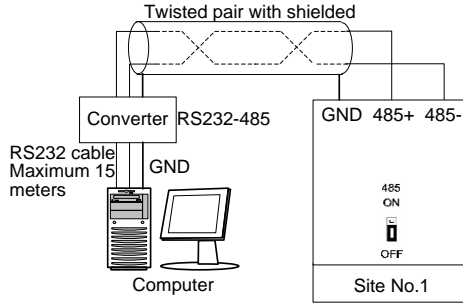

Appendix Fig.1 A inverter connected to a computer

- ◆ Several inverters connected to a computer

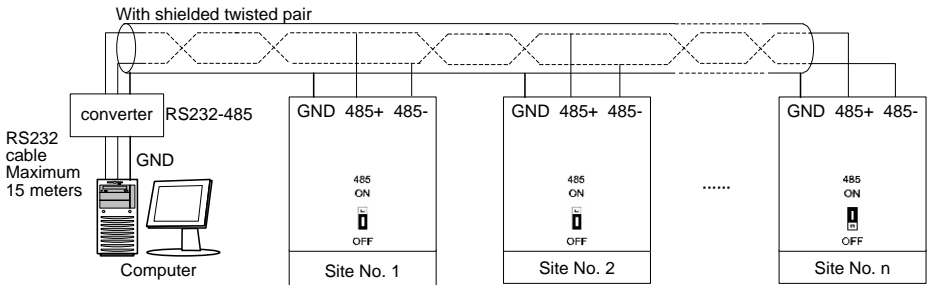

The switch of terminal resistor of the inverter at the most distant place id turn to ON, start, the internal 100Ω terminal compatible resistance

Appendix Fig.2 Several inverters connected to a computer

Warranty Agreement

1. The warranty period of the product is 18 months (refer to the bar-code on the equipment).
During the warranty period, if the product fails or is damaged under the condition of normal use by following the instructions, SANTERNO will be responsible for free maintenance.
2. Within the warranty period, maintenance will be charged for the damages caused by the following reasons:
 - a. Improper use or repair/modification without prior permission
 - b. Fire, flood, abnormal voltage, other disasters and secondary disaster
 - c. Hardware damage caused by dropping or transportation after procurement
 - d. Improper operation
 - e. Trouble out of the equipment (for example, external device)
3. If there is any failure or damage to the product, please correctly fill out the Product Warranty Card in detail.
4. The maintenance fee is charged according to the latest Maintenance Price List of SANTERNO.
5. The Product Warranty Card is not re-issued. Please keep the card and present it to the maintenance personnel when asking for maintenance.
6. If there is any problem during the service, contact agent or SANTERNO directly.
7. This agreement shall be interpreted by SANTERNO.