

YASKAWA

Sky Elevator[®]

YASKAWA AC Drive L1000A

AC Drive for Elevator Applications

Quick Start Guide

Type: CIMR-LC

Models: 200 V Class: 1.5 to 110 kW

400 V Class: 1.5 to 110 kW

To properly use the product, read this manual thoroughly and retain for easy reference, inspection, and maintenance. Ensure the end user receives this manual.

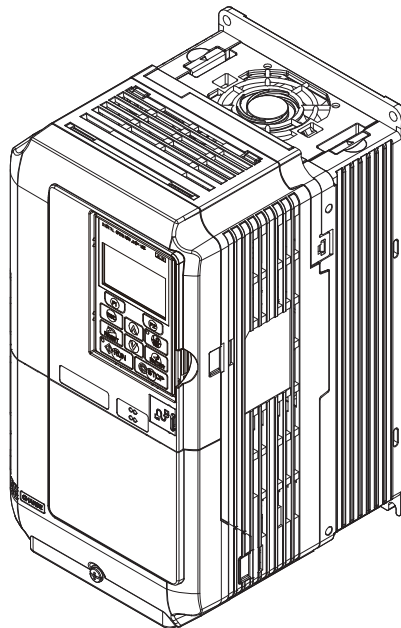

Copyright © 2009 YASKAWA ELECTRIC CORPORATION. All rights reserved.

All rights reserved. No part of this publication may be reproduced, stored in a retrieval system, or transmitted, in any form, or by any means, mechanical, electronic, photocopying, recording, or otherwise, without the prior written permission of Yaskawa. No patent liability is assumed with respect to the use of the information contained herein. Moreover, because Yaskawa is constantly striving to improve its high-quality products, the information contained in this manual is subject to change without notice. Every precaution has been taken in the preparation of this manual. Nevertheless, Yaskawa assumes no responsibility for errors or omissions. Neither is any liability assumed for damages resulting from the use of the information contained in this publication.

Table of Contents

1	SAFETY INSTRUCTIONS AND GENERAL WARNINGS	4
2	MECHANICAL INSTALLATION.....	9
3	ELECTRICAL INSTALLATION	12
4	KEYPAD OPERATION.....	19
5	START UP	21
6	FINE ADJUSTMENTS	34
7	PARAMETER TABLE.....	37
8	TROUBLESHOOTING	42
9	SAFE DISABLE INPUT FUNCTION.....	48
10	EN81-1/20 CONFORM CIRCUIT WITH ONE MOTOR CONTACTOR.....	51
11	EN81-20 CONFORM CIRCUIT WITH NO MOTOR CONTACTOR	52
12	UL STANDARDS	53

1 Safety Instructions and General Warnings

Yaskawa Electric supplies component parts for use in a wide variety of industrial applications. The selection and application of Yaskawa products remain the responsibility of the equipment designer or end user. Yaskawa accepts no responsibility for the way its products are incorporated into the final system design. Under no circumstances should any Yaskawa product be incorporated into any product or design as the exclusive or sole safety control. Without exception, all controls should be designed to detect faults dynamically and fail safely under all circumstances. All products designed to incorporate a component part manufactured by Yaskawa must be supplied to the end user with appropriate warnings and instructions as to the safe use and operation of that part. Any warnings provided by Yaskawa must be promptly provided to the end user. Yaskawa offers an express warranty only as to the quality of its products in conforming to standards and specifications published in the manual. **NO OTHER WARRANTY, EXPRESS OR IMPLIED, IS OFFERED.** Yaskawa assumes no liability for any personal injury, property damage, losses, or claims arising from misapplication of its products.

◆ Applicable Documentation

The following manuals are available for L1000A series drives:

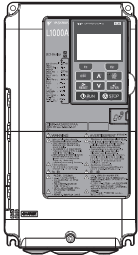
	L1000A Series AC Drive Technical Manual This manual provides detailed information on parameter settings, drive functions, and MEMOBUS/Modbus specifications. Use this manual to expand drive functionality and to take advantage of higher performance features.
	L1000A Series AC Drive Quick Start Guide Read this manual first. This guide is packaged together with the product. It contains basic information required to install and wire the drive, in addition to an overview of fault diagnostics, maintenance, and parameter settings. Use the information in this book to prepare the drive for a trial run with the application and for basic operation.

◆ General Warnings

⚠ WARNING

- Read and understand the manuals available before installing, operating or servicing this drive.
- All warnings, cautions, and instructions must be followed.
- All work must be performed by qualified personnel.
- The drive must be installed according to this manual and local codes.

Heed the safety messages in this manual.

The operating company is responsible for any injuries or equipment damage resulting from failure to heed the warnings in this manual.

⚠ WARNING

Indicates a hazardous situation, which, if not avoided, could result in death or serious injury.

The following conventions are used to indicate safety messages in this manual:

⚠ CAUTION

Indicates a hazardous situation, which, if not avoided, could result in minor or moderate injury.

NOTICE

Indicates a property damage message.

◆ Safety Warnings

WARNING

Inadvertent Movement Hazard

Clear all personnel above or inside the elevator car before performing a test run.

Failure to comply could result in death or serious injury.

Before using Leveling Distance Control, make sure that parameters for Traction Sheave Diameter (o1-20), Deceleration Distance (S5-11) and the Stop Distance (S5-12) are set to the correct units and values.

The elevator will not stop at the designated location or an overrun will occur which may cause injury to personnel if parameters o1-20, S5-11, and S5-12 are set incorrectly.

Electrical Shock Hazard

Do not attempt to modify or alter the drive in any way not explained in this manual.

Yaskawa is not responsible for the damage caused by modification of the product made by the user. Failure to comply could result in death or serious injury from operation of damaged equipment.

Do not touch any terminals before the capacitors have fully discharged.

Failure to comply could result in death or serious injury.

Before wiring terminals, disconnect all power to the equipment. The internal capacitor remains charged even after the power supply is turned off. The charge indicator LED will extinguish when the DC bus voltage is below 50 Vdc. To prevent electric shock, wait at least five minutes after all indicators are off and measure the DC bus voltage level to confirm safe level.

Do not allow unqualified personnel to use equipment.

Failure to comply could result in death or serious injury.

Maintenance, inspection, and replacement of parts must be performed only by authorized personnel familiar with installation, adjustment, and maintenance of AC drives.

Do not change wiring, remove covers, connectors or options cards, or attempt to service the drive with power applied to the drive.

Failure to comply could result in death or serious injury. Disconnect all power to the drive and check for unsafe voltages before servicing.

Always ground the motor-side grounding terminal.

Improper equipment grounding could result in death or serious injury by contacting the motor case.

Do not perform work on the drive while wearing loose clothing, jewelry or without eye protection.

Failure to comply could result in death or serious injury.

Remove all metal objects such as watches and rings, secure loose clothing, and wear eye protection before beginning work on the drive.

Never short the output circuits of the drive.

Do not short the output circuits of the drive. Failure to comply could result in death or serious injury.

When using a PM motor, make sure to block the rotor before performing work on the motor or drive output circuit.

A PM motor generates electrical power if rotated. If connected to the drive, the drive main circuit will be charged even if the power supply is off. Touching live parts in the drive or output circuit may result in death or serious injury.

Make sure the protective earthing conductor complies with technical standards and local safety regulations.

When an EMC filter is installed, the leakage current exceeds 3.5 mA. Therefore according to IEC/EN 61800-5-1 automatic power supply interruption in case of discontinuity of the protective earthing conductor must be provided or a protective earthing conductor with a cross section of at least 10 mm² (Cu) or 16 mm² (Al) must be used.

1 Safety Instructions and General Warnings

WARNING

Use appropriate equipment for residual current monitoring / detection (RCM / RCD).

This drive can cause a residual current with a DC component in the protective earthing conductor. Where a residual current operated protective or monitoring device is used for protection in case of direct or indirect contact, always use an RCM or RCD of type B according to IEC/EN 60755.

Sudden Movement Hazard

Stay clear of the motor during rotational Auto-Tuning. The motor may start operating suddenly.

During automatic starting of equipment, the machine may start moving suddenly, which could result in death or serious injury.

System may start unexpectedly upon application of power, resulting in death or serious injury.

Clear all personnel from the drive, motor, and machine area before applying power. Secure covers, couplings, shaft keys, and machine loads before applying power to the drive.

Use parameter S1-12 to enable/disable automatic switching of the Motor Contactor Control output signal during Auto-Tuning.

When using setting S1-12 = 1 or 2, ensure that the multi-function output terminals are properly wired and in the correct state before setting parameter S1-12.

Failure to comply could result in damage to the drive, serious injury or death.

Fire Hazard

Drive Short-Circuit Current Rating

Install adequate branch circuit protection according to applicable local codes and this Installation Manual.

Failure to comply could result in fire and damage to the drive or injury to personnel.

The device is suitable for use on a circuit capable of delivering not more than 100,000 RMS symmetrical amperes, 240 Vac maximum (200 V class) and 480 Vac maximum (400 V class), and 600 Vac maximum (600 V class) when protected by branch circuit protection devices specified in this manual.

Do not use an improper voltage source.

Failure to comply could result in death or serious injury by fire.

Verify that the rated voltage of the drive matches the voltage of the incoming power supply before applying power.

Do not use improper combustible materials in drive installation, repair or maintenance.

Failure to comply could result in death or serious injury by fire. Attach the drive or braking resistors to metal or other noncombustible material.

Do not connect the AC power line to the output motor terminals of the drive.

Failure to comply could result in death or serious injury by fire as a result of drive damage from line voltage application to output terminals.

- Do not connect AC line power to output terminals U, V, and W.
- Make sure that the power supply lines are connected to main circuit input terminals R/L1, S/L2, T/L3 (or R/L1 and S/L2 for single-phase power).

Tighten all terminal screws to the specified tightening torque.

Loose electrical connections could result in death or serious injury by fire due to overheating of electrical connections.

CAUTION

Crush Hazard

Do not carry the drive by the front cover.

Failure to comply may result in minor or moderate injury from the main body of the drive falling.

⚠ CAUTION**Burn Hazard**

Do not touch the heatsink or braking resistor hardware until a powered-down cooling period has elapsed.

NOTICE**Equipment Hazard**

Observe proper electrostatic discharge procedures (ESD) when handling the drive and circuit boards.

Failure to comply may result in ESD damage to the drive circuitry.

If a fuse is blown or equipment for residual current monitoring/detection (RCM/RCD) is tripped, check the wiring and the selection of the peripheral devices.

Check for short circuits or ground faults on the secondary side of fuses and equipment for residual current monitoring/detection (RCM/RCD), and check the wiring and the selection of peripheral devices. Remove the cause of the problem and then turn the power supply on again. If the cause cannot be identified, do not turn on the power supply or attempt to operate the equipment.

Do not restart the drive or immediately operate the peripheral devices if a fuse is blown or equipment for residual current monitoring/detection (RCM/RCD) is tripped.

Check the wiring and the selection of peripheral devices to identify the cause.

Contact your supplier before restarting the drive or the peripheral devices if the cause cannot be identified.

Never connect or disconnect the motor from the drive while the drive is outputting voltage.

Improper equipment sequencing could result in damage to the drive.

Do not perform a withstand voltage test on any part of the unit.

Failure to comply could result in damage to the sensitive devices within the drive. Use power off resistance checks to determine shortcircuits.

Do not operate damaged equipment.

Failure to comply could result in further damage to the equipment.

Do not connect or operate any equipment with visible damage or missing parts.

Do not use unshielded cable for control wiring.

Failure to comply may cause electrical interference resulting in poor system performance. Use shielded twisted-pair wires and ground the shield to the ground terminal of the drive.

Only connect recommended devices to the drives braking transistor terminals.

Failure to comply could result in damage to the drive or braking circuit.

Carefully review instruction manual TOBP C720600 0□ when connecting a braking option to the drive.

Do not modify the drive circuitry.

Failure to comply could result in damage to the drive and will void warranty.

Yaskawa is not responsible for modification of the product made by the user. This product must not be modified.

Check all the wiring to ensure that all connections are correct after installing the drive and connecting other devices.

Failure to comply could result in damage to the drive.

Improper application of devices on drive output circuits can damage the drive

Do not connect unapproved LC or RC interference suppression filters, capacitors, ground fault circuits, or overvoltage protection devices to the drive.

NOTICE

Check the motor rotation and elevator movement direction prior to starting up the drive.

The drive puts out voltage in phase sequence U-V-W with an Up command. Make sure the elevator moves up if the motor is supplied with this phase sequence.

Always remove the ropes when performing Rotational Auto-Tuning.

During Rotational Auto-Tuning the drive turns the motor for a certain time. Not removing the ropes might result in damage to the equipment.

When using a PM motor, make sure the motor can handle the maximum current delivered by the drive.

Operating the motor with too high current may result in demagnetization.

◆ Precautions for CE Low Voltage Directive Compliance

This drive has been tested according to IEC/EN 61800-5-1: 2007, and it fully complies with the Low Voltage Directive. The following conditions must be met to maintain compliance when combining this drive with other devices:

- Do not use drives in areas with pollution higher than degree 2 and overvoltage category 3 in accordance with IEC/EN 664.
- Ground the neutral point of the main power supply for 400 V Class drives.

In the drives L□2□0145 through 2□0415 and L□4□0112 through 4□0216, the wire bending space (space between terminals and cable entry point) provided is smaller than recommended in the IEC/EN61800-5-1.

We declared the CE marking based on the harmonized standards. Refer to the Technical Manual or contact Yaskawa for more detailed information.

2 Mechanical Installation

◆ Upon Receipt

Perform the following tasks after receiving the drive:

- Inspect the drive for damage. If the drive appears damaged upon receipt, contact your supplier.
- Verify receipt of the correct model by checking the information on the nameplate. If you have received the wrong model, contact your supplier.

◆ Installation Environment

For optimum performance life of the drive, install the drive in an environment that meets the conditions listed below.

Environment	Conditions
Installation Area	Indoors
Ambient Temperature	IP20 enclosure: -10 to +50°C Drive reliability improves in environments without wide temperature fluctuations. When using the drive in an enclosure panel, install a cooling fan or air conditioner in the area to ensure that the air temperature inside the enclosure does not exceed the specified levels. Do not allow ice to develop on the drive.
Humidity	95% RH or less and free of condensation
Storage Temperature	-20 to +60°C
Surrounding Area	Install the drive in an area free from: <ul style="list-style-type: none"> • oil mist and dust • metal shavings, oil, water or other foreign materials • radioactive materials • combustible materials (e.g., wood) • harmful gases and liquids • excessive vibration • chlorides • direct sunlight
Altitude	1000 m or lower, up to 3000 m with derating (for details refer to the Technical Manual)
Vibration	10 to 20 Hz at 9.8 m/s ² 20 to 55 Hz at 5.9 m/s ² (2□0008 to 2□0180, 4□0005 to 4□0150) or 2.0 m/s ² (CIMR-L□2□0215 to 2□0415, CIMR-L□4□0180 to 4□0216)
Orientation	Install the drive vertically to maintain maximum cooling effects.

◆ Installation Orientation and Spacing

Always install the drive in an upright position. Leave space around the unit for proper cooling as shown in the figure on the right.

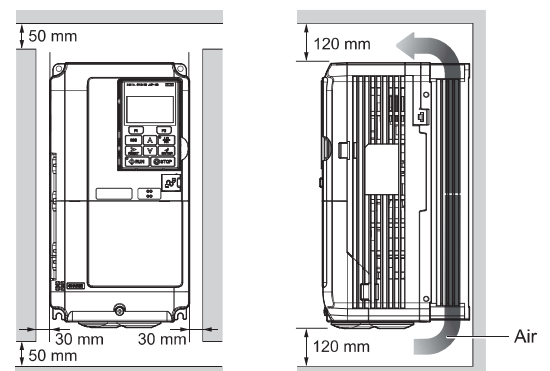

◆ Instructions on Installation

Eye bolts are used to install the drive or to temporarily lift the drive when replacing it. The drive can be installed in an enclosure panel or on a wall. Do not leave the drive suspended by the wires in a horizontal or vertical position for long periods of time. Do not transport the drive over long distances. Read the following precautions and instructions before installing the drives.

WARNING! Be sure to observe the following instructions and precautions. Failure to comply could result in minor or moderate injury and damage to the drive from falling equipment.

- Before using wires to suspend the drive vertically and horizontally, make sure that the drive front cover, terminal blocks and other drive components are securely fixed with screws.
- Do not subject the drive to vibration or impact greater than 1.96 m/s^2 (0.2 G) while it is suspended by the wires.
- Do not overturn the drive while it is suspended by the wires.
- Do not leave the drive suspended by the wires for long periods of time.

■ Horizontal Suspension of the Drive (CIMR-L□2□0346, 2□0415, 4□0216)

To make a wire hanger or frame for use when lifting the drive with a crane, lay the drive in a horizontal position and pass a wire through the holes of the four eye bolts.

When lifting the drive, confirm that the spring washer is fully closed. If not, the drive may become deformed or damaged when lifted.

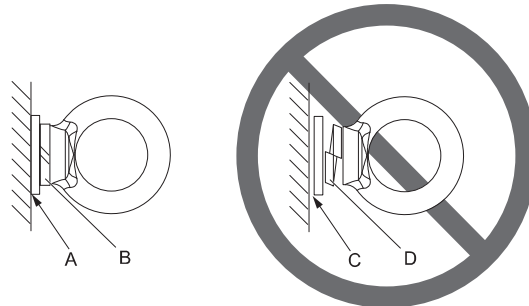

A – No space between drive and washer
B – Spring washer: Fully closed

C – Space between drive and washer
D – Spring washer: Open

Figure 1 Details of Spring Washers

■ Vertical Suspension of the Drive (CIMR-L□2□0346, 2□0415, 4□0216)

CIMR-L□2□0346, 2□0415, 4□0216

When vertical suspension of the drive is required in an enclosure panel, the orientation of the eye bolts for these drive models can be easily changed by turning the eye bolts counterclockwise 90 degrees.

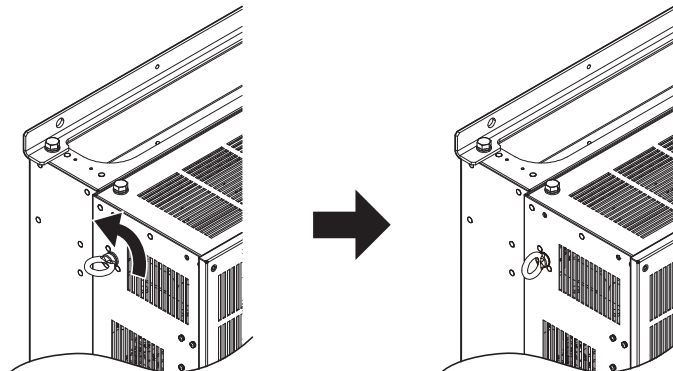

Figure 2 Adjusting Angle of Eye Bolts (CIMR-L□2□0346, 2□0415, 4□0216)

◆ Degree of Protection

The degree of protection of L1000A drives is IP20. Install the drive in a cabinet if higher degree of protection is required.

◆ Dimensions

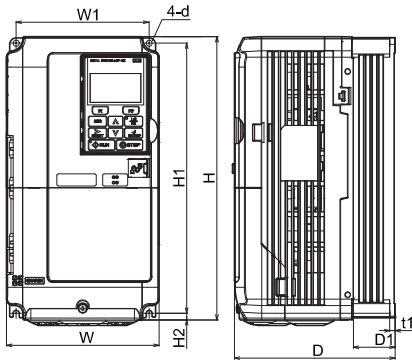

Figure 1

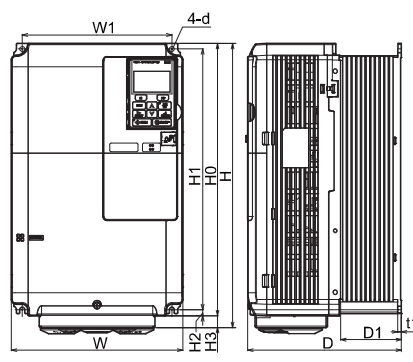

Figure 2

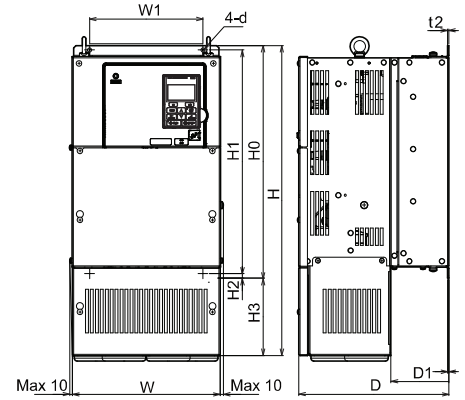
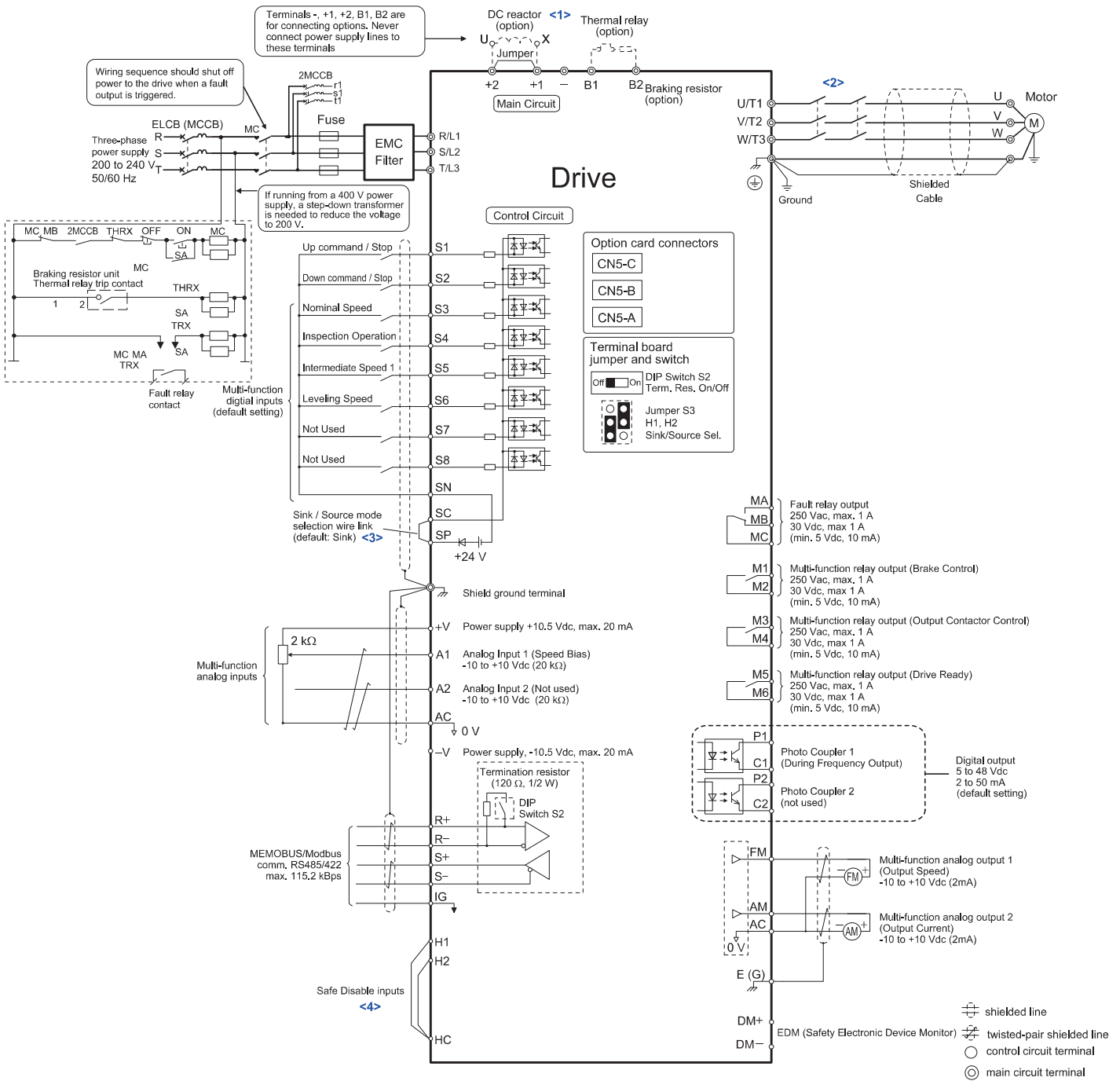

Figure 3

Model CIMR-L□	Fig.	Dimensions (mm)												Weight (kg)
		W	H	D	W1	H0	H1	H2	H3	D1	t1	t2	d	
2□0008	1	140	260	147	122	—	248	6	—	38	5	—	M5	3.2
2□0011		140	260	147	122	—	248	6	—	38	5	—	M5	3.2
2□0018		140	260	164	122	—	248	6	—	55	5	—	M5	3.5
2□0025		140	260	167	122	—	248	6	—	55	5	—	M5	4.0
2□0033		140	260	167	122	—	248	6	—	55	5	—	M5	4.0
2□0047		180	300	187	160	—	284	8	—	75	5	—	M5	5.6
2□0060		220	350	197	192	—	335	8	—	78	5	—	M6	8.7
2□0075	2	220	365	197	192	350	335	8	15	78	5	—	M6	9.7
2□0085	3	254	534	258	195	400	385	7.5	134	100	2.3	2.3	M6	23
2□0115		279	614	258	220	450	435	7.5	164	100	2.3	2.3	M6	28
2□0145		329	630	283	260	550	535	7.5	80	110	2.3	2.3	M6	40
2□0180		329	630	283	260	550	535	7.5	80	110	2.3	2.3	M6	40
2□0215		456	868	330	325	705	680	12.5	163	130	3.2	3.2	M10	81
2□0283		456	868	330	325	705	680	12.5	163	130	3.2	3.2	M10	86
2□0346		504	1038	350	370	800	773	13	238	130	4.5	4.5	M12	105
2□0415	504	1038	350	370	800	773	13	238	130	4.5	4.5	M12	105	
4□0005	1	140	260	147	122	—	248	6	—	38	5	—	M5	3.2
4□0006		140	260	164	122	—	248	6	—	55	5	—	M5	3.4
4□0009		140	260	164	122	—	248	6	—	55	5	—	M5	3.5
4□0015		140	260	167	122	—	248	6	—	55	5	—	M5	3.9
4□0018		140	260	167	122	—	248	6	—	55	5	—	M5	3.9
4□0024		180	300	167	160	—	284	8	—	55	5	—	M5	5.4
4□0031		180	300	187	160	—	284	8	—	75	5	—	M5	5.7
4□0039	220	350	197	192	—	335	8	—	78	5	—	M6	8.3	
4□0045	3	254	465	258	195	400	385	7.5	65	100	2.3	2.3	M6	23
4□0060		279	515	258	220	450	435	7.5	65	100	2.3	2.3	M6	27
4□0075		329	630	258	260	510	495	7.5	120	105	2.3	3.2	M6	39
4□0091		329	630	258	260	510	495	7.5	120	105	2.3	3.2	M6	39
4□0112		329	630	283	260	550	535	7.5	80	110	2.3	2.3	M6	43
4□0150		329	630	283	260	550	535	7.5	80	110	2.3	2.3	M6	45
4□0180		456	868	330	325	705	680	12.5	163	130	3.2	3.2	M10	85
4□0216	504	1038	350	370	800	773	13	238	130	4.5	4.5	M12	103	

3 Electrical Installation

The figure below shows the main and control circuit wiring.



- <1> Remove the jumper when installing a DC reactor. Models CIMR-L□2□0085 through 2□0415 and 4□0045 through 4□0216 come with a built-in DC reactor.
- <2> The drive provides a stop function in compliance with Stop Category 0 (EN 60204-1) and “Safe Torque Off” (IEC/EN 61800-5-2). It has been designed to meet the requirements of the ISO/EN 13849-1, Category 3 PLD, and IEC/EN 61508, SIL2. Using this function the number of motor contactors can be reduced to one. Refer to **Safe Disable Input Function on page 48** for details.
- <3> Never short terminals SP and SN, as doing so will damage the drive.
- <4> Disconnect the wire jumper between H1-HC and H2-HC when utilizing the Safe Disable inputs.

Note:

1. The drive should be implemented in the system in a way so that a drive fault causes the safety chain to open. Always use terminal MA-MB-MC for this purpose.
2. Even though no fault is present, conditions where the drive may not start can occur, e.g. when the Digital Operator is left in the Programming Mode. Use the “Drive Ready” output (default set to terminals M5-M6) to interlock operation in such situations.

◆ Wiring Specification

■ Main Circuit

Use the fuses and line filters listed in the table below when wiring the main circuit. Do not to exceed the given tightening torque values.

Model CIMR-L□	EMC Filter		Main Fuse [Bussmann]	Recom. Motor Cable (mm ²)	Main Circuit Terminal Sizes			
	Manufacturer: Schaffner	Manufacturer: Block			R/L1,S/L2,T/L3, U/T1,V/T2,W/T3, -, +1, +2	+3	B1, B2	⊕
2□0008	FS5972-18-07	FB-40014A	FWH-70B	2.5	M4	-	M4	M4
2□0011								
2□0018	FS5972-35-07	FB-40025A	FWH-90B	6	M4	-	M4	M5
2□0025								
2□0033	FS5972-60-07	FB-40060A	FWH-100B	10	M6	-	M5	M6
2□0047								
2□0060	FS5972-100-35	FB-40072A	FWH-200B	16	M8	-	M5	M8
2□0075								
2□0085	FS5972-170-40	FB-40105A	FWH-300A	25	M10	-	M8	M8
2□0115								
2□0145	FS5972-170-40	FB-40170A	FWH-350A	50	M10	-	M8	M8
2□0180								
2□0180	FS5972-250-37	FB-40250A	FWH-400A	70	M10	M10	-	M10
2□0215								
2□0215	FS5972-410-99	FB-40414A	FWH-600A	95 × 2P	M12	M10	-	M12
2□0283								
2□0346	FS5972-600-99	FB-40675A	FWH-700A	240	M12	M10	-	M12
2□0415								
2□0415	FS5972-600-99	FB-40675A	FWH-800A	300	M12	M10	-	M12
2□0415								
4□0005	FS5972-18-07	FB-40008A	FWH-70B	2.5	M4	-	M4	M4
4□0006								
4□0009	FS5972-35-07	FB-40014A	FWH-90B	4	M4	-	M4	M5
4□0015								
4□0018	FS5972-35-07	FB-40025A	FWH-80B	4	M4	-	M4	M5
4□0018								
4□0024	FS5972-60-07	FB-40044A	FWH-100B	6	M5	-	M5	M6
4□0031								
4□0039	FS5972-60-07	FB-40060A	FWH-125B	16	M6	-	M5	M6
4□0045								
4□0060	FS5972-100-35	FB-40072A	FWH-200B	25	M8	-	M8	M8
4□0075								
4□0091	FS5972-170-35	FB-40105A	FWH-250A	35	M8	M8	-	M8
4□0112								
4□0112	FS5972-170-35	FB-40170A	FWH-350A	50	M10	M10	-	M10
4□0150								
4□0150	FS5972-250-37	FB-40250A	FWH-400A	70	M10	M10	-	M10
4□0180								
4□0180	FS5972-250-37	FB-40250A	FWH-500A	95	M10	M10	-	M10
4□0216								
4□0216	FS5972-410-99	FB-40250A	FWH-600A	120	M10	M10	-	M10
4□0216								

Tightening Torque Values

Tighten the main circuit terminals using the torque values provided in the table below.

Terminal Size	M4	M5 <1>	M6	M8	M10	M12
Tightening Torque (N·m)	1.2 to 1.5	2.0 to 2.5	4.0 to 6.0	9.0 to 11.0	18.0 to 23.0	32.0 to 40.0

<1> The tightening torque differs for the following terminals.
 For use with CIMR-L□4A0024 and 4A0031
 R/L1, S/L2, T/L3, U/T1, V/T2, W/T3, -, +1, +2: 3.6 to 4.0 N·m
 B1, B2: 2.7 to 3.0 N·m

3 Electrical Installation

■ Control Circuit

The control terminal board is equipped with screwless terminals. Always use wires within the specifications listed below. For safe wiring, Yaskawa recommends solid wires or flexible stranded wires with ferrules. Use ferrules with a length of 8 mm.

Wire Type	Wire Size (mm ²)
Solid	0.2 to 1.5
Stranded	0.2 to 1.0
Stranded wire with ferrule	0.25 to 0.5

◆ EMC Filter Installation

This drive has been tested in accordance with European standards IEC/EN 61800-3. Install the drive and wire the main circuit as described below.

1. Install an appropriate EMC noise filter to the input side. See the table in [Main Circuit on page 13](#) or refer to the Technical Manual for details.
2. Place the drive and EMC noise filter in the same enclosure.
3. Use braided shield cable for motor and control circuit wiring.
4. Remove any paint or dirt from ground connections for minimal ground impedance.
5. Make sure the protective earthing conductor complies with technical standards and local safety regulations.

WARNING! Electrical Shock Hazard.

Because the leakage current exceeds 3.5 mA in models CIMR-L□4A0370 and larger, IEC/EN 61800-5-1 states that either the power supply must be automatically disconnected in case of discontinuity of the protective earthing conductor or a protective earthing conductor with a cross-section of at least 10 mm² (Cu) or 16 mm² (Al) must be used. Failure to comply may result in death or serious injury.

6. Install an AC or DC reactor for IEC/EN 12015 compliance. Refer to the Technical Manual or contact your supplier for details.

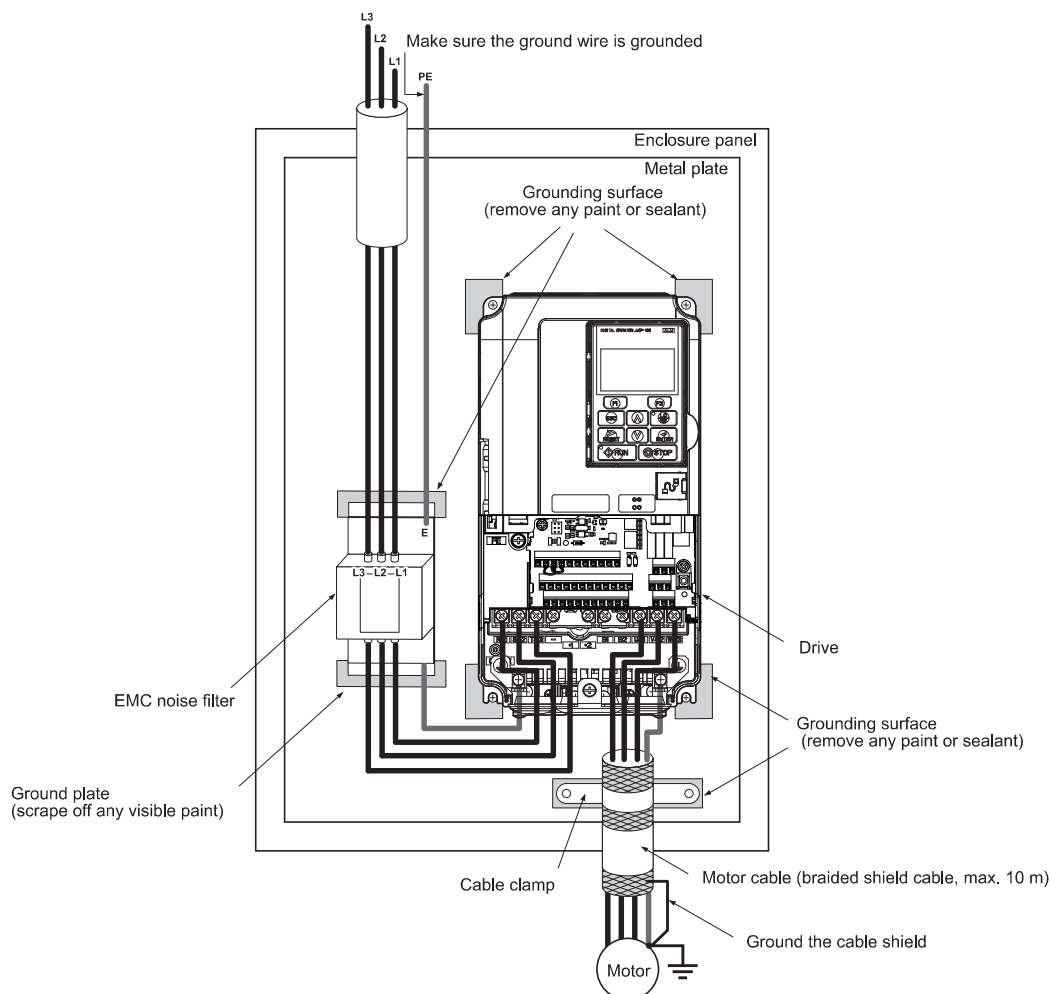

◆ Main and Control Circuit Wiring

■ Wiring the Main Circuit Input

Note the following precautions when wiring the main circuit input:

- Use only fuses recommended in *Main Circuit on page 13*.
- When using residual current monitoring or detection devices (RCM / RCD), make sure the devices are designed for use with AC drives (e.g., type B according to IEC/EN 60755).
- If using an input switch, make sure that the switch does not operate more frequently than once every 30 minutes.
- Use a DC reactor or AC reactor on the input side of the drive:
 - To suppress harmonic current.
 - To improve the power factor on the power supply side.
 - When using an advancing capacitor switch.
 - With a large capacity power supply transformer (over 600 kVA).

■ Wiring the Main Circuit Output

Note the following precautions for the output circuit wiring:

- Do not connect any load other than a three-phase motor to the output side of the drive.
- Never connect a power source to the drive output.
- Never short or ground the output terminals.
- Do not use phase correction capacitors.
- Check the control sequence to make sure that the motor contactor is not turned ON or OFF during drive operation. Turning on the motor contactor while voltage is output causes an inrush current that is likely to trigger the drive's overcurrent protection.

Note: The drive provides a Safe Disable function that can be utilized to reduce the number of motor contactors to one. Refer to *Safe Disable Input Function on page 48* for details.

■ Ground Connection

Take the following precautions when grounding the drive:

- Make sure the ground conductor complies with the general technical standards and local regulations.
- Keep ground wires as short as possible.
- Always make sure the ground impedance is conform to the requirements of local safety and installation regulations.
- Never share the ground wire with other devices such as welding machines, etc.
- Do not loop the ground wire when using more than one drive.

■ Control Circuit Wiring Precautions

Note the following precautions for wiring the control circuits:

- Separate control circuit wiring from main circuit wiring and other high-power lines.
- Separate wiring for control circuit terminals M1 to M6, MA, MB, and MC (contact output) from wiring to other control circuit terminals.
- Use twisted-pair or shielded twisted-pair cables for control circuits to prevent operating faults.
- Ground the cable shields with the maximum contact area of the shield and ground.
- Cable shields should be grounded on both cable ends.
- Note that flexible wires with ferrules may fit tightly into the terminals. To disconnect them, grasp the wire end with a pair of pliers, release the terminal using a straight-edge screwdriver, turn the wire for about 45°, and pull it gently out of the terminal. For details, refer to the Technical Manual. Use this procedure for removing the wire link between HC, H1, and H2 when the Safe Disable function is utilized.

3 Electrical Installation

■ Main Circuit Terminals

Terminal		Type			Function	
200 V Class	Model CIMR-L□	2□0008 to 2□0075	2□0085, 2□0115	2□0145 to 2□0415		
400 V Class		4□0005 to 4□0039	4□0045, 4□0060	4□0075 to 4□0216		
R/L1, S/L2, T/L3		Main circuit power supply input			Connects line power to the drive	
U/T1, V/T2, W/T3		Drive output			Connects to the motor	
B1, B2		Braking resistor		Not available	Available for connecting a braking resistor or a braking resistor unit option	
+2		<ul style="list-style-type: none"> DC reactor connection (+1, +2) (remove the shorting bar between +1 and +2) DC power supply input (+1, -) 	Not available		For connection <ul style="list-style-type: none"> of the drive to a DC power supply (terminals +1 and - are not UL approved) of dynamic braking options 	
+1, -			DC power supply input (+1, -)	• DC power supply input (+1, -)		
+3				• Braking unit connection (+3, -)		
⊕		-			Grounding terminal	

Note: Use terminal B1 and - terminals when installing the braking unit (CDBR type) to the drives with built-in braking transistor (2□0008 to 2□0115, 4□0005 to 4□0060).

■ Control Circuit Terminals

The figure below shows the control circuit terminal arrangement. The drive is equipped with screwless terminals.

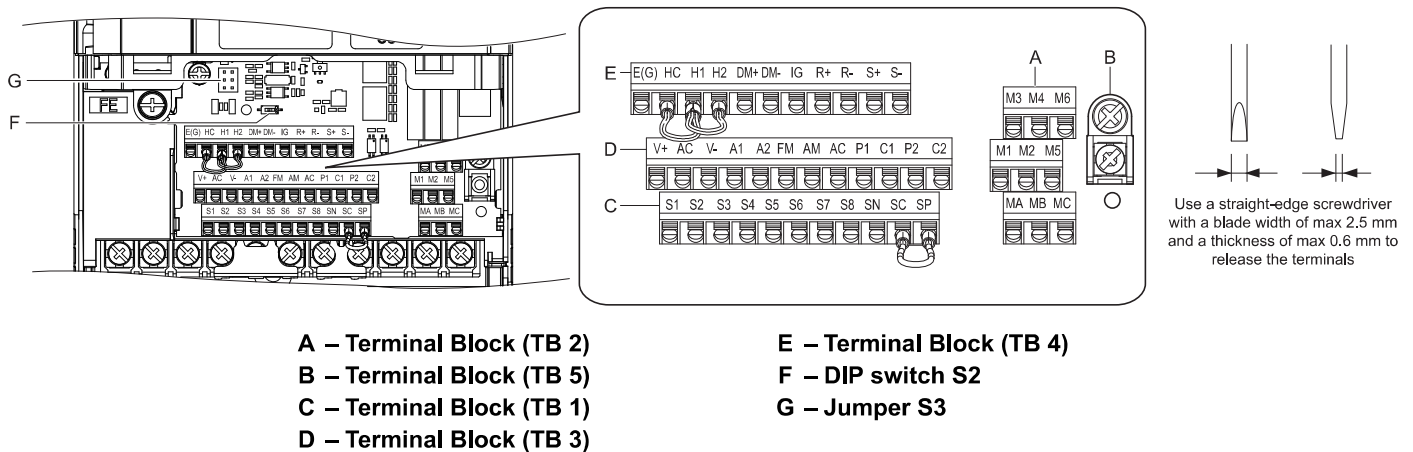

DIP switch S2 and jumper S3 are located on the terminal board. Set them as described below.

S2	RS422/485 Termination Resistor	Off <input type="checkbox"/> On <input checked="" type="checkbox"/>
S3	Safe Disable Input Sink/Source/External Supply Selection	 Sink Source External 24 Vdc Power Supply

■ Sinking/Sourcing Mode (NPN/PNP Selection)

Use a wire link between terminals SC and SP or SC and SN to select between Sink mode, Source mode or external power supply for the digital inputs S1 to S8 as shown below (Default: Sink mode, internal power supply).

Note: Never short terminals SP and SN as doing so will damage the drive.

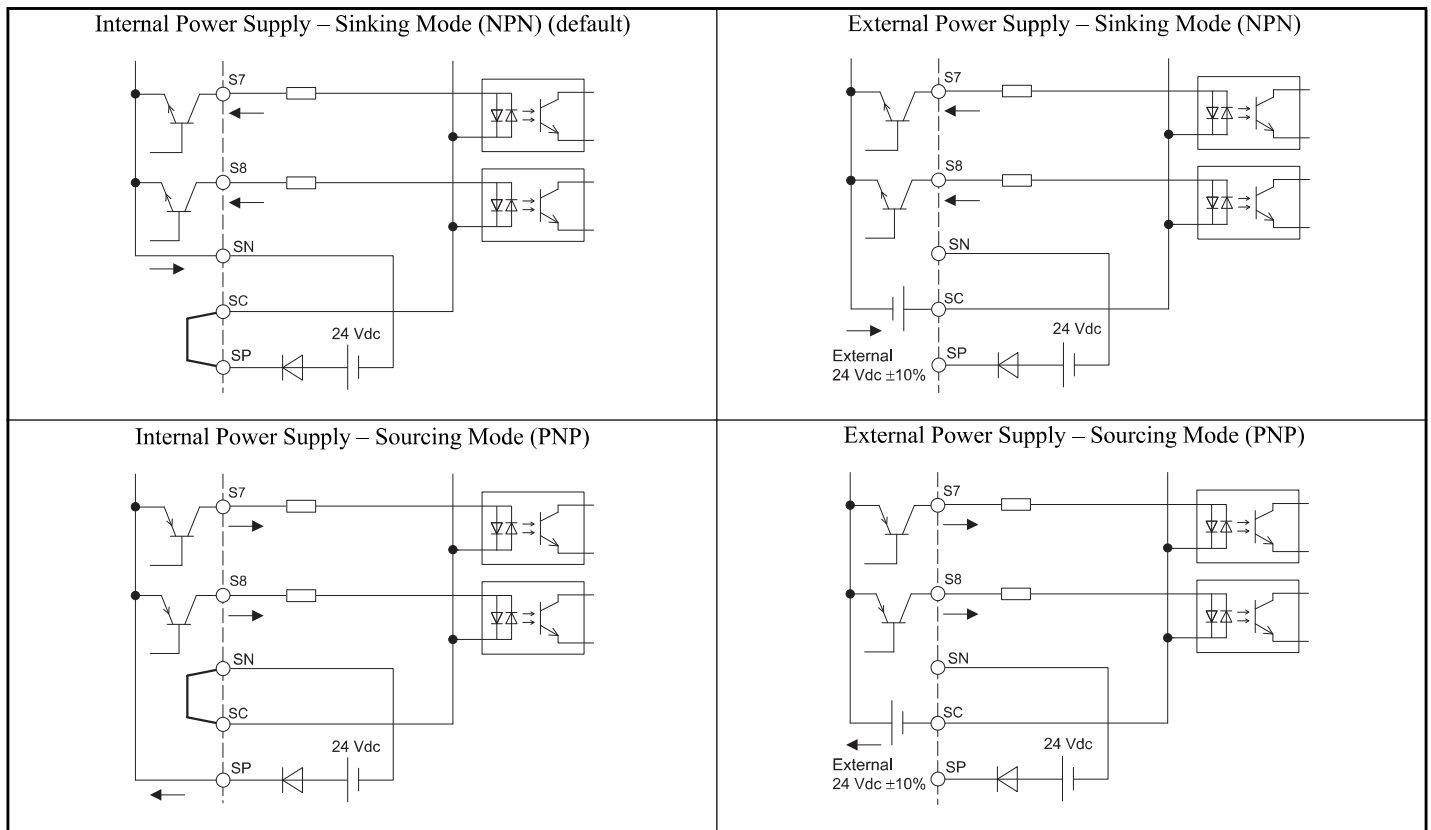

■ Control Circuit Terminal Functions

Type	No.	Terminal Name (Function)	Function (Signal Level) Default Setting
Digital Inputs	S1	Up Command (Closed: Up, Open: Stop)	Photocoupler 24 Vdc, 8 mA Use the wire link between terminals SC and SN or between SC and SP to select sinking or sourcing, and to select the power supply.
	S2	Down Command (Closed: Down, Open: Stop)	
	S3	Multi-function input 3 (Nominal Speed)	
	S4	Multi-function input 4 (Inspection Operation)	
	S5	Multi-function input 5 (Intermediate Speed 1)	
	S6	Multi-function input 6 (Leveling Speed)	
	S7	Multi-function input 7 (Not used)	
	S8	Multi-function input 8 (Not used)	
Digital Input Power Supply	SC	Multi-function input common	Photocoupler, 24 Vdc, 8 mA Use the wire link between terminals SC and SN or between SC and SP to select sinking or sourcing, and to select the power supply.
	SN	0 V	
	SP	+24 Vdc	
Safe Disable Inputs	H1	Safe Disable input 1	24 Vdc, 8 mA One or both open: Drive output disabled Both closed: Normal operation Internal impedance: 3.3 kΩ Off time of at least 1 ms Set the S3 jumper to select sinking or sourcing, and to select the power supply.
	H2	Safe Disable input 2	
	HC	Safe Disable function common	

3 Electrical Installation

Type	No.	Terminal Name (Function)	Function (Signal Level) Default Setting
Analog Inputs	+V	Power supply for analog inputs	10.5 Vdc (max. allowable current 20 mA)
	-V	Power supply for analog inputs	-10.5 Vdc (max. allowable current 20 mA)
	A1	Multi-function analog input 1 (Speed Reference Bias)	-10 to 10 Vdc, 0 to 10 Vdc (input impedance: 20 kΩ)
	A2	Multi-function analog input 2 (Not used)	-10 to 10 Vdc, 0 to 10 Vdc (input impedance: 20 kΩ)
	AC	Analog Input common	0 V
Fault Relay	E (G)	Ground for shielded lines and option cards	-
	MA	N.O. output	30 Vdc, 10 mA to 1 A; 250 Vac, 10 mA to 1 A Minimum load: 5 Vdc, 10 mA
	MB	N.C. output	
MC	Fault output common		
Multi-Function Relay Output	M1	Relay output 1 (Brake Control)	
	M2		
	M3	Relay output 2 (Output Contactor Control)	
	M4		
	M5	Relay output 3 (Drive Ready)	
M6			
Multi-Function Photocoupler Output	P1	Photocoupler output 1 (During frequency output 2)	Photocoupler output 48 Vdc, 2 to 50 mA
	C1		
	P2	Photocoupler output 2 (Not used)	
	C2		
Monitor Output	FM	Analog monitor output 1 (Output speed)	-10 to +10 Vdc, 0 to +10 Vdc
	AM	Analog monitor output 2 (Output current)	
	AC	Monitor common	0 V
Safety Monitor Output	DM+	Safety monitor output	Outputs status of Safe Disable function. Closed when both Safe Disable channels are closed. Up to +48 Vdc 50 mA.
	DM-	Safety monitor output common	

NOTICE: The terminals HC, H1, H2 are used for the Safe Disable function. Safe Disable can be used to enable/disable the drive. If special requirements are fulfilled, it can also be utilized for reducing the number of motor contactors to one. Refer to [Safe Disable Input Function on page 48](#) for details. Always remove the wire link between HC, H1, or H2 when using Safe Disable.

NOTICE: The wiring length to terminals HC, H1 and H2 should not exceed 30 m.

NOTICE: When connecting a reactive load such as a relay coil to a photo coupler output, attach a flywheel diode to the load (relay coil) like shown below. Ensure the diode rating is greater than the circuit voltage.

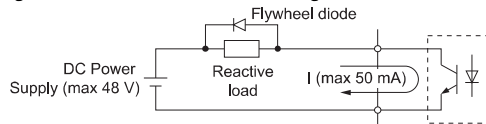

4 Keypad Operation

◆ Digital Operator and Keys

The digital operator is used to program the drive, to start and stop it, and to display fault information. The LEDs indicate the operating status of the drive.



■ Keys and Functions

Key	Name	Function
	Function Key (F1, F2)	The functions assigned to F1 and F2 vary depending on the menu that is currently displayed. The name of each function appears in the lower half of the display window.
	ESC Key	<ul style="list-style-type: none"> Returns to the previous display. Moves the cursor one space to the left. Pressing and holding this button will return to the Speed Reference display.
	RESET Key	<ul style="list-style-type: none"> Moves the cursor to the right. Resets the drive to clear a fault situation.
	RUN Key	<p>Starts the drive in the LOCAL mode.</p> <p>The Run LED:</p> <ul style="list-style-type: none"> is on, when the drive is operating the motor. flashes when decelerating to stop (“ramp to stop”), or when the speed reference is 0. flashes quickly when the drive is disabled by a DI, when the drive was stopped using an Emergency Stop command via the digital inputs, or when an Up/Down command is active during power up.
	Up Arrow Key	Scrolls up to display the next item, selects parameter numbers and increments setting values.
	Down Arrow Key	Scrolls down to display the previous item, selects parameter numbers and decrements setting values.
	STOP Key	Stops drive operation.
	ENTER Key	<ul style="list-style-type: none"> Enters parameter values and settings. Selects a menu item to move between displays.
	LO/RE Selection Key	Switches drive control between the operator (LOCAL) and the control circuit terminals (REMOTE). The LED is on when the drive is in the LOCAL mode (operation from keypad).
	ALM LED Light	<p>On: When the drive detects a fault.</p> <p>Flashing:</p> <ul style="list-style-type: none"> When an alarm occurs. When oPE is detected. When a fault or error occurs during Auto-Tuning.

◆ Menu Structure and Modes

The following illustration explains the operator keypad menu structure.

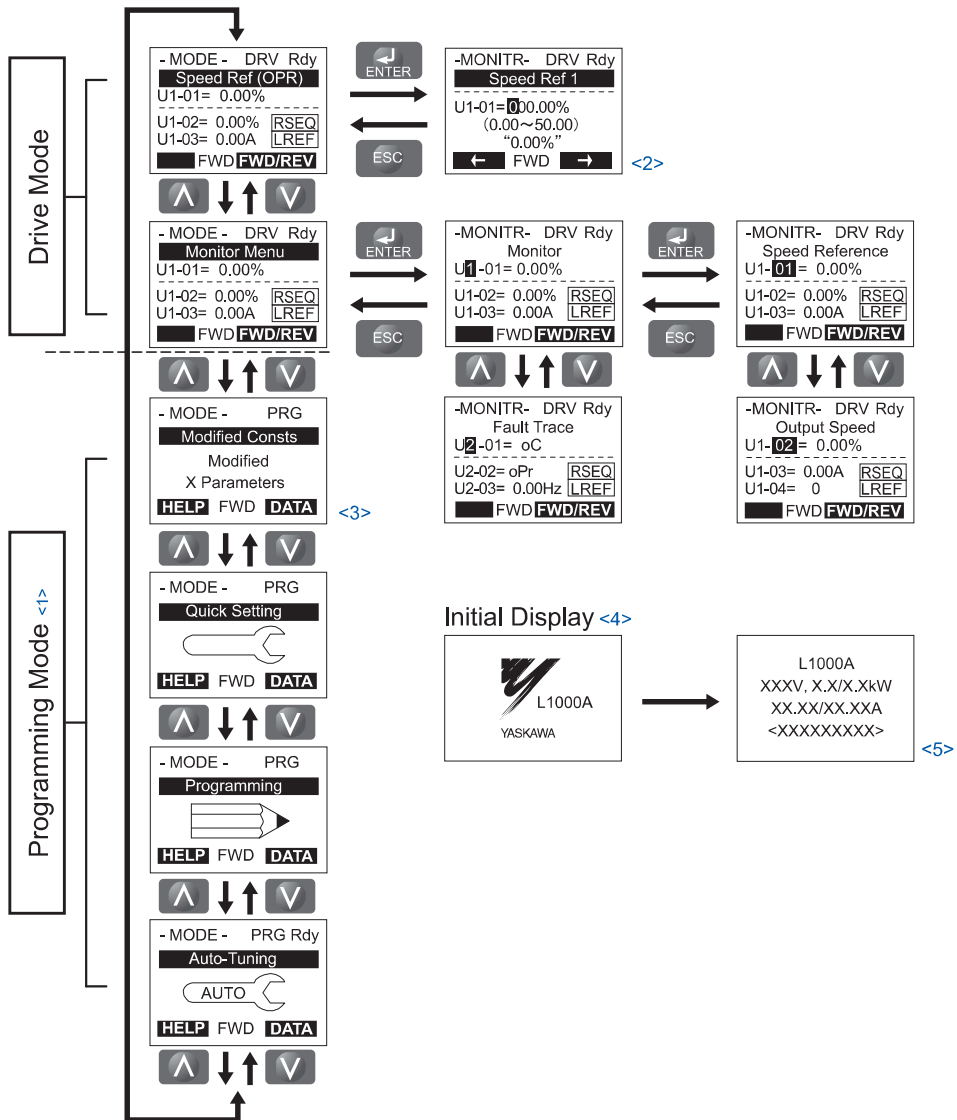

<1> Drive cannot operate the motor.

<2> Flashing characters are shown as 0.

<3> X characters are shown in this manual. The LCD Operator will display the actual setting values.

<4> The speed reference appears after the initial display which shows the product name.

<5> The information that appears on the display will vary depending on the drive.

5 Start Up

◆ Drive Setup Procedure

The illustration below shows the basic setup procedure. The steps from switching on power are explained more detailed on the following pages.

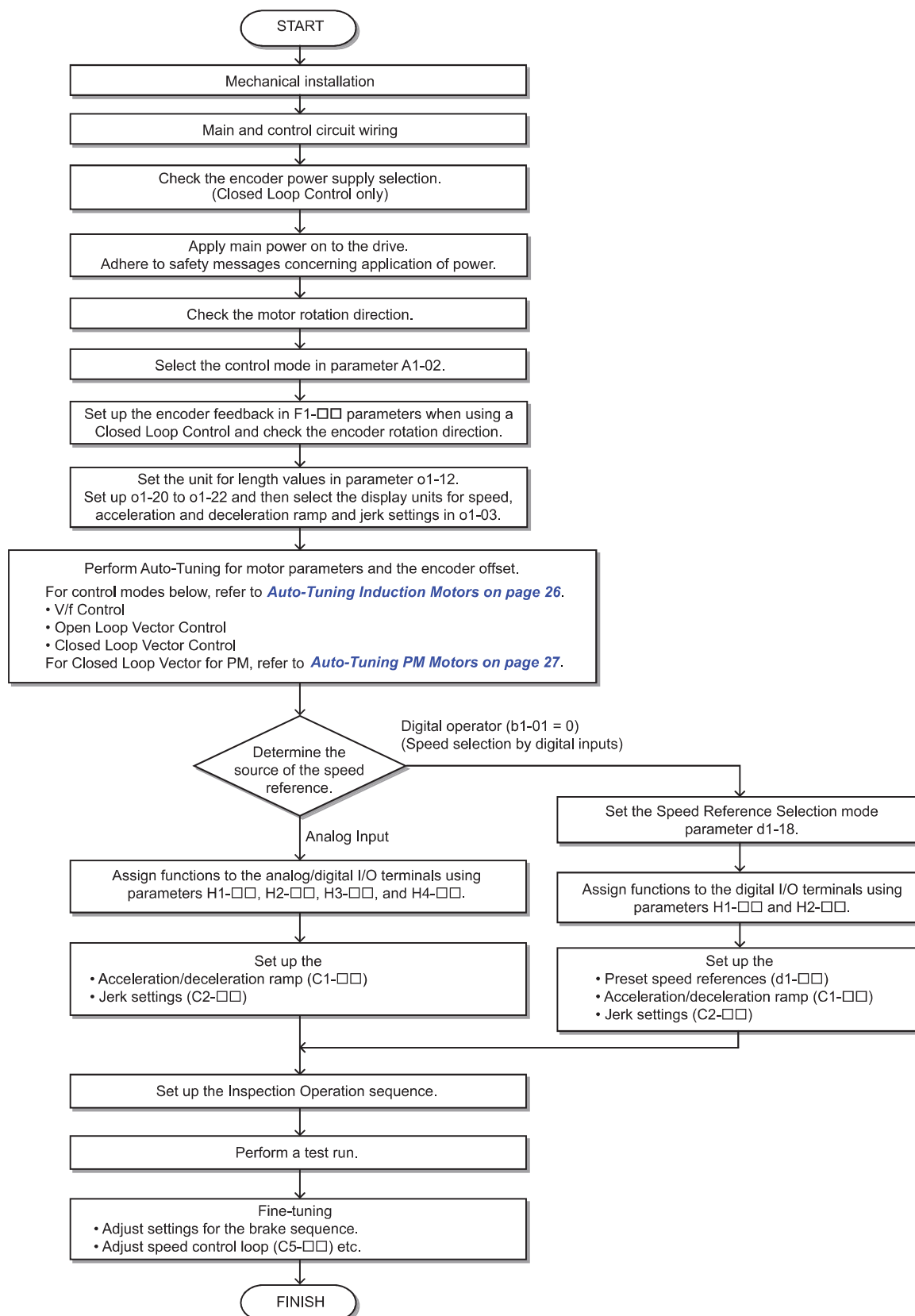

Note: Set parameter H5-11 to 1 when setting parameters using MEMOBUS/Modbus communications.

◆ Power On

Before turning on the power supply:

- Make sure all wires are connected properly. Also make sure motor phases are connected in the right sequence.
- Make sure that no screws, loose wire ends, or tools are left in the drive.
- If an encoder option card is used make sure the encoder is wired correctly and the power supply on the option card is set according to the encoder specification.

After turning the power on, the drive mode display should appear and no fault or alarm should be displayed. In case of any error refer to [Troubleshooting on page 42](#).

◆ Control Mode Selection

When the drive is first powered up, one of the four control modes must be selected to match the application. Note that Closed Loop Vector modes require encoder feedback cards. The table below indicates possible control modes depending on the motor type and shows the required encoder feedback card.

Machine Type	Control Mode	A1-02 Setting	Encoder Option Card
Induction motor without encoder	V/f Control	0	No card required
	Open Loop Vector Control	2	No card required
Induction motor with incremental encoder	Closed Loop Vector Control	3	PG-B3 / PG-X3
Permanent magnet motor with EnDat 2.1/01, EnDat 2.2/01, or EnDat 2.2/22 encoder	Closed Loop Vector Control for PM motors	7	PG-F3
Permanent magnet motor with ERN1387 encoder	Closed Loop Vector Control for PM motors	7	PG-E3
Yaskawa IPM motor with incremental encoder	Closed Loop Vector Control for PM motors	7	PG-X3

◆ Motor Rotation Direction Setup

Depending on the elevator configuration it might be necessary to change the motor direction in order to have the elevator traveling up when the Up command is given to the drive. Do the following to check the motor rotation direction.

- The drive puts out voltage in U-V-W phase sequence when an Up command is input. Check the motor rotation with this phase sequence (for most motors clockwise seen from the shaft side).
- If the motor drives the elevator in the up direction with a U-V-W sequence, make sure parameter b1-14 is set to 0.
- If the motor drives the elevator in the down direction with a U-V-W sequence, set parameter b1-14 is set to 1.

Note: Always perform motor rotation direction setup prior to setting the encoder rotation direction.

◆ Encoder Setup

■ Encoder Resolution Setup

Set the encoder resolution (incremental signal in case of absolute encoders with Sin/Cos tracks) in parameter F1-01.

■ Encoder Rotation Direction Setup

Perform the following steps to make sure the encoder rotation direction is set up correctly in the drive.

If information about the signal sequence of the encoder are available

- Check the sequence of encoder phases A and B when the motor drives the elevator in the up direction.
- If the encoder A phase leads phase B, make sure F1-05 is set to 0.
- If the encoder B phase leads phase A, make sure F1-05 is set to 1.

If no information about the signal sequence of the encoder are available

- Turn the motor manually in elevator up direction while checking the value of monitor U1-05.
- If the value in U1-05 is positive, the set encoder direction is correct.
- If the value in U1-05 is negative, alter the setting of parameter F1-05.

Note: Always set the motor rotation direction prior to the encoder rotation direction. Refer to [Motor Rotation Direction Setup on page 22](#).

◆ Digital Operator Display Unit Selection

The drive allows to choose between different display units for speed related parameters and monitors, acceleration and deceleration ramps and jerk settings. The units can be selected using parameter o1-03 like shown below.

o1-03 Setting	Display Unit		
	Speed Setting/Monitors (d1-□□, U1-02, U1-02,...)	Accel/Decel Ramps (C1-□□)	Jerk Settings (C2-□□)
0	0.01 Hz	0.01 s	0.01 s
1 (default)	0.01%		
2	1 rpm		
3	User defined		
4	0.01 m/s	0.01 m/s ²	0.01 m/s ³
5	0.01 m/s		

When using setting 4 or 5 certain mechanical data have to be programmed to the drive prior to changing o1-03. Perform the following steps.

1. Make sure motor data are set up correctly. Verify the setting of the maximum output frequency in parameter E1-04 and the setting for the number of motor poles in parameter E2-04 or E5-04.
2. Set the traction sheave diameter in units of mm to parameter o1-20.
3. Set the correct roping to parameter o1-21.
4. If a mechanical gear is used, set the gear ratio ($n_{\text{Motor}}/n_{\text{Traction Sheave}}$) to parameter o1-22. If a gearbox is not used, make sure o1-22 is set to 1.0.
5. Change parameter o1-03 to setting 4 or 5. The unit and setting values of related parameters will be changed automatically.

Refer to *Parameter Table on page 37* for details.

◆ Motor Data and Encoder Auto-Tuning

■ Auto-Tuning Types

Auto-Tuning automatically programs the drive's motor and motor control related parameters. Select between Auto-Tuning methods listed below.

Motor Data Tuning Modes for Induction Motors (A1-02 = 0, 2, or 3)

Type	Setting	Requirements and Benefits	Control Mode (A1-02)		
			V/f (0)	OLV (2)	CLV (3)
Rotational Auto-Tuning	T1-01 = 0	<ul style="list-style-type: none"> Rotational Auto-Tuning gives the most accurate results, and is therefore highly recommended if possible. Motor must run freely or with light load (<30%), i.e. ropes have to be removed. 	No	Yes	Yes
Stationary Auto-Tuning 1	T1-01 = 1	<ul style="list-style-type: none"> Automatically calculates motor parameters needed for vector control. Use if ropes cannot be removed. Note that the accuracy is less than with Rotational Auto-tuning. 	No	Yes	Yes
Stationary Auto-Tuning for Line-to-Line Resistance	T1-01 = 2	<ul style="list-style-type: none"> Used for V/f Control or in vector control modes when the drive was set up properly before and the motor cable has changed. 	Yes	Yes	Yes
Stationary Auto-Tuning 2	T1-01 = 4	<ul style="list-style-type: none"> A motor test report is available. The no-load current and the rated slip have must be entered from the test report, all other motor-related parameters are calculated automatically. Use if ropes cannot be removed and if slip and no-load current data are available. 	No	Yes	Yes

Motor Data Tuning Modes for Permanent Magnet Motors (A1-02 = 7)

Type	Setting	Requirements and Benefits
Motor Data Input	T2-01 = 0	<ul style="list-style-type: none"> Use if a motor test report is available. Input motor data like on test report. Make sure to convert data into the correct unit before if necessary.
Stationary Auto-Tuning	T2-01 = 1	<ul style="list-style-type: none"> Use if a motor test report is not available. Input motor data like on name plate. Make sure to convert data into the correct unit before. The drive automatically calculates the motor data.
Stationary Auto-Tuning for Stator Resistance	T2-01 = 2	<ul style="list-style-type: none"> Tunes stator resistance only. Should be performed if the motor cable has changed.
Rotational Back EMF Constant Auto-Tuning	T2-01 = 11	<ul style="list-style-type: none"> Used the Motor Induction Voltage (E5-24) if no data are available. Should be performed after Motor data have been set and the encoder offset has been adjusted. The motor must be uncoupled from the mechanical system (remove ropes).
Auto-Tuning of PG-E3 Encoder Characteristics <I>	T2-01 = 12	Perform this Auto-Tuning to obtain accurate position data from the motor rotor for driving a PM motor.

<I> Available in drive software versions PRG: 7017 or later.

Auto-Tuning of PG-E3 encoder characteristics requires a PG-E3 option with software version 1102 or later. To identify the PG-E3 software version, refer to the PG-E3 labeling on the option, in the field designated "C/N" (S + four digit number).

Encoder Offset Tuning Modes for Permanent Magnet Motors (A1-02 = 7)

Encoder Offset Tuning measures the angle between the encoder zero pulse and the rotor orientation. It needs to be performed when a drive is setup the first time or after initialization, when the motor rotation direction or encoder rotation direction has been changed or when the encoder was replaced.

Type	Setting	Requirements and Benefits
Initial Magnet Pole Search Parameters Auto-Tuning	T2-01 = 3	<ul style="list-style-type: none"> Attempts to detect the motor rotor position, judges if the encoder offset can be tuned using Stationary Encoder Offset Tuning and sets parameters needed for Initial Magnet Pole Search (n8-36, n8-37). Should be performed after motor Auto-Tuning in order to decide the encoder tuning method. <p>Note: When using a PG-X3 card with an incremental encoder and this tuning fails, the motor cannot be driven using an incremental encoder. Change the encoder to an absolute encoder.</p>
Stationary Encoder Offset Auto-Tuning	T2-01 = 4	<ul style="list-style-type: none"> Tunes the encoder offset without rotating the motor. If the encoder offset cannot be tuned properly by this method run Rotating Encoder Offset Tuning.
Rotational Encoder Offset Auto-Tuning	T2-01 = 10	<ul style="list-style-type: none"> Tunes the encoder offset while rotating the motor. Motor and mechanical system must be uncoupled (ropes must be removed from traction sheave).

■ Auto-Tuning of PG-E3 Encoder Characteristics

This feature optimizes the drive settings for the characteristics of the PG-E3 speed-control option card for the ERN1387 encoder (manufactured by HEIDENHAIN) while rotating the motor. Perform Auto-Tuning to obtain accurate position data from the motor rotor for driving a PM motor. This type of Auto-Tuning automatically sets the characteristics of the PG-E3 option card for the ERN1387 encoder in parameters F1-66 to F1-81 (Encoder Adjust 1 to 16).

- Note:**
1. The motor rotates during execution of Auto-Tuning of PG-E3 encoder characteristics. Before starting, refer to the drive technical manual.
 2. Auto-Tuning of PG-E3 encoder characteristics adjusts the unique characteristics of the ERN1387 encoder connected to the drive by using a PG-E3 option card. This type of tuning should be performed when setting up the drive or after replacing the encoder or drive. The signal lines between the PG-E3 option card and the ERN1387 encoder must be connected between the R+ and R- terminals while this type of tuning is performed.
 3. The setting values of parameters F1-66 to F1-81 are reset to factory default values when A1-03 is set to 2220. The setting values of parameters F1-66 to F1-81 are modified at completion of Auto-Tuning of PG-E3 encoder characteristics.

■ Tuning Mode Selection and Data Input

For Auto-Tuning, enter the Auto-Tuning menu (via the T parameters) and perform the steps shown in the figure below. Data required from the motor nameplate will vary depending on the type of Auto-Tuning selected. This example shows the procedure for performing Rotational Auto-Tuning of an induction motor in Open Loop Vector control.

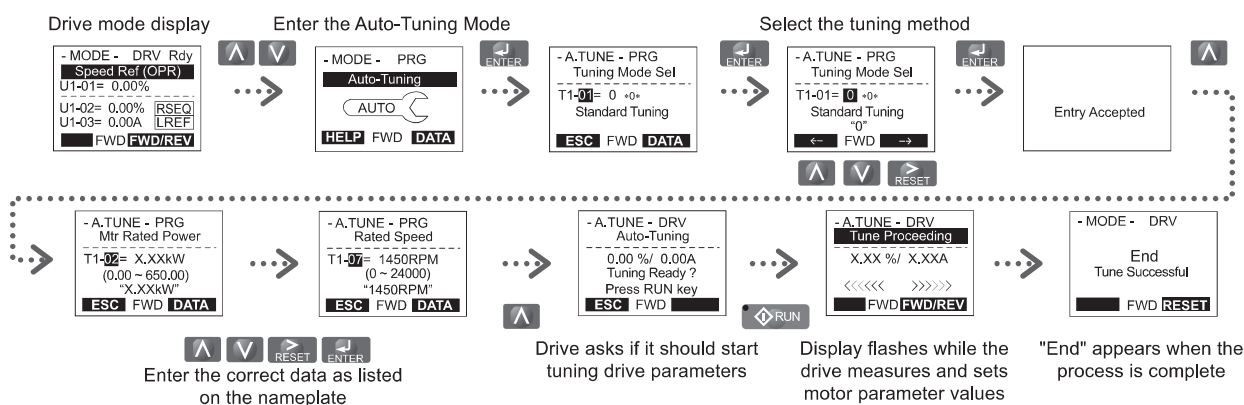

If Auto-Tuning cannot be performed for some reason (no-load operation impossible, etc.), then set the maximum frequency and voltage in the E1-□□ parameters and enter the motor data manually into the E2-□□ parameters for induction motors or E5-□□ parameters for PM motors. Refer to [Auto-Tuning Errors on page 46](#).

■ Precautions

WARNING! Sudden Movement Hazard. Use parameter S1-12 to enable/disable automatic switching of the Motor Contactor Control output signal during Auto-Tuning. When using setting S1-12 = 1, ensure that the multi-function output terminals are properly wired and in the correct state before setting parameter S1-12 = 1 Enabled. Failure to comply could result in damage to the drive, serious injury or death.

- Rotational Auto-Tuning T1-01 = 0 (recommended method)
 - Rotational Auto-Tuning provides more accurate tuning results compared to Non-Rotating Auto-Tuning.
 - Perform Rotational Auto-Tuning when the motor can be uncoupled from the elevator mechanical system (remove ropes from traction sheave).
 - Make sure to release the mechanical brake (if installed) for Rotational Auto-Tuning methods.
- Stationary Auto-Tuning T1-01 = 1, 2, or 4 (alternate method)
 - Perform Stationary Auto-Tuning when the motor and mechanical system cannot be uncoupled.
 - Make sure that the mechanical brake remains applied for all Stationary Auto-Tuning methods.
- When using a motor contactor, make sure it remains closed during the Auto-Tuning process.
- Ensure H1 and H2 signals are ON when performing Auto-Tuning.
- Ensure the motor is securely mounted and bolted in place prior to Auto-Tuning.
- Do not touch the motor until the Auto-Tuning process is complete. Voltage is applied to the motor during the tuning process, even though the motor may not be rotating.
- To cancel Auto-Tuning, press the STOP key on the digital operator.
- During Auto-Tuning the motor is started and stopped repeatedly and may also rotate. When the tuning is finished, "END" will appear on the operator panel. Do not touch the motor until this display is shown and the motor has completely stopped.

■ Auto-Tuning Procedure
Auto-Tuning Induction Motors

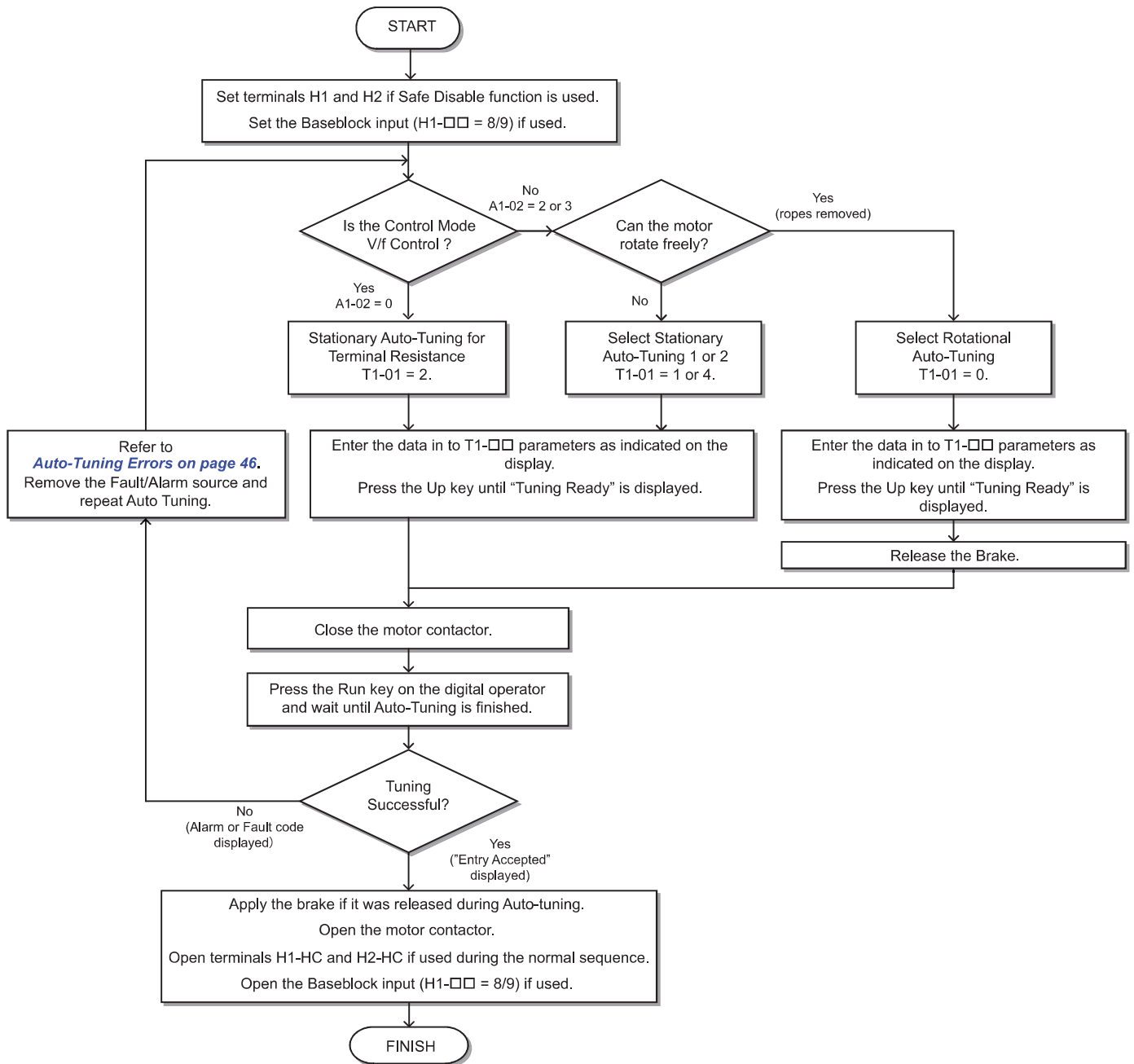

Auto-Tuning PM Motors

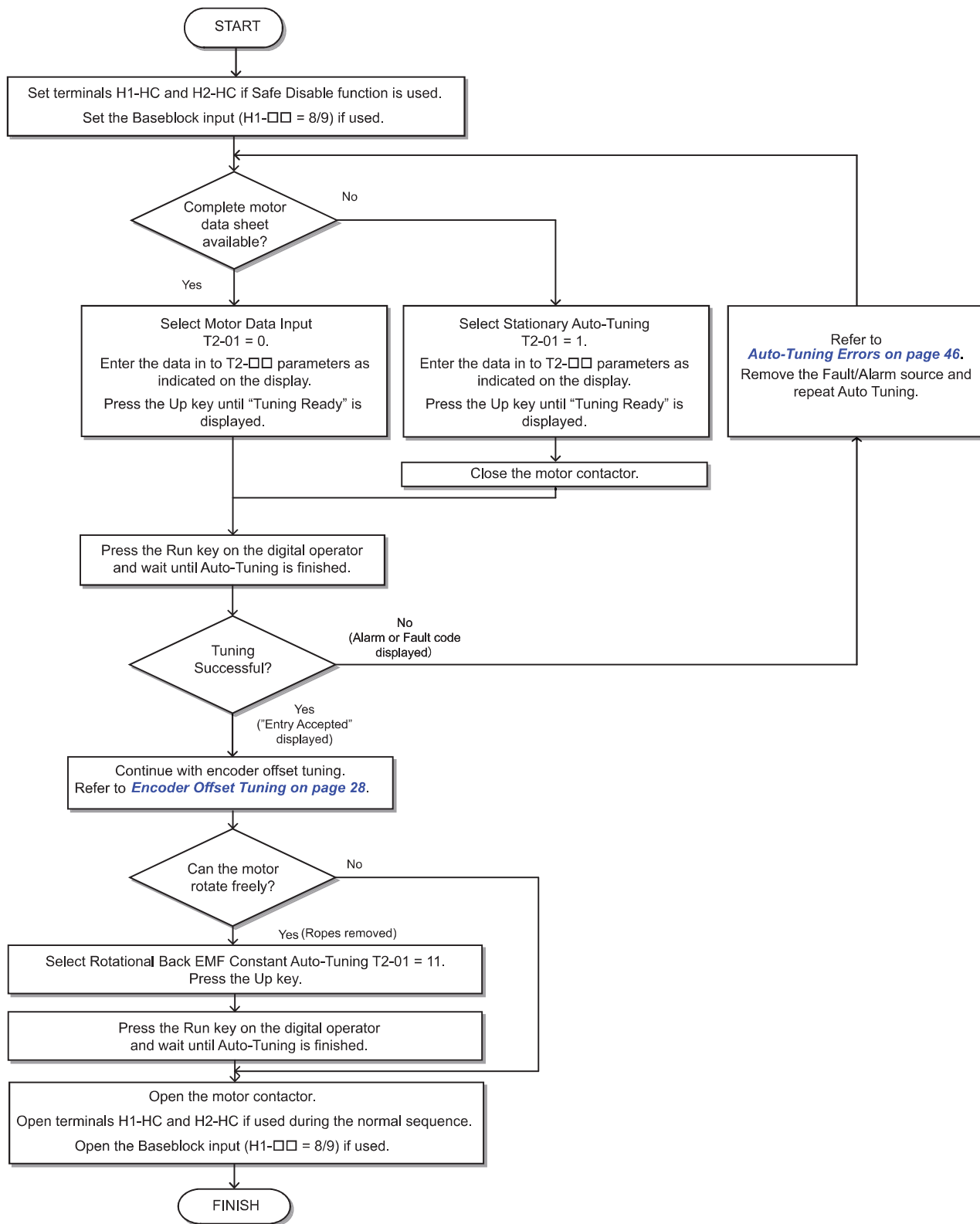

Encoder Offset Tuning

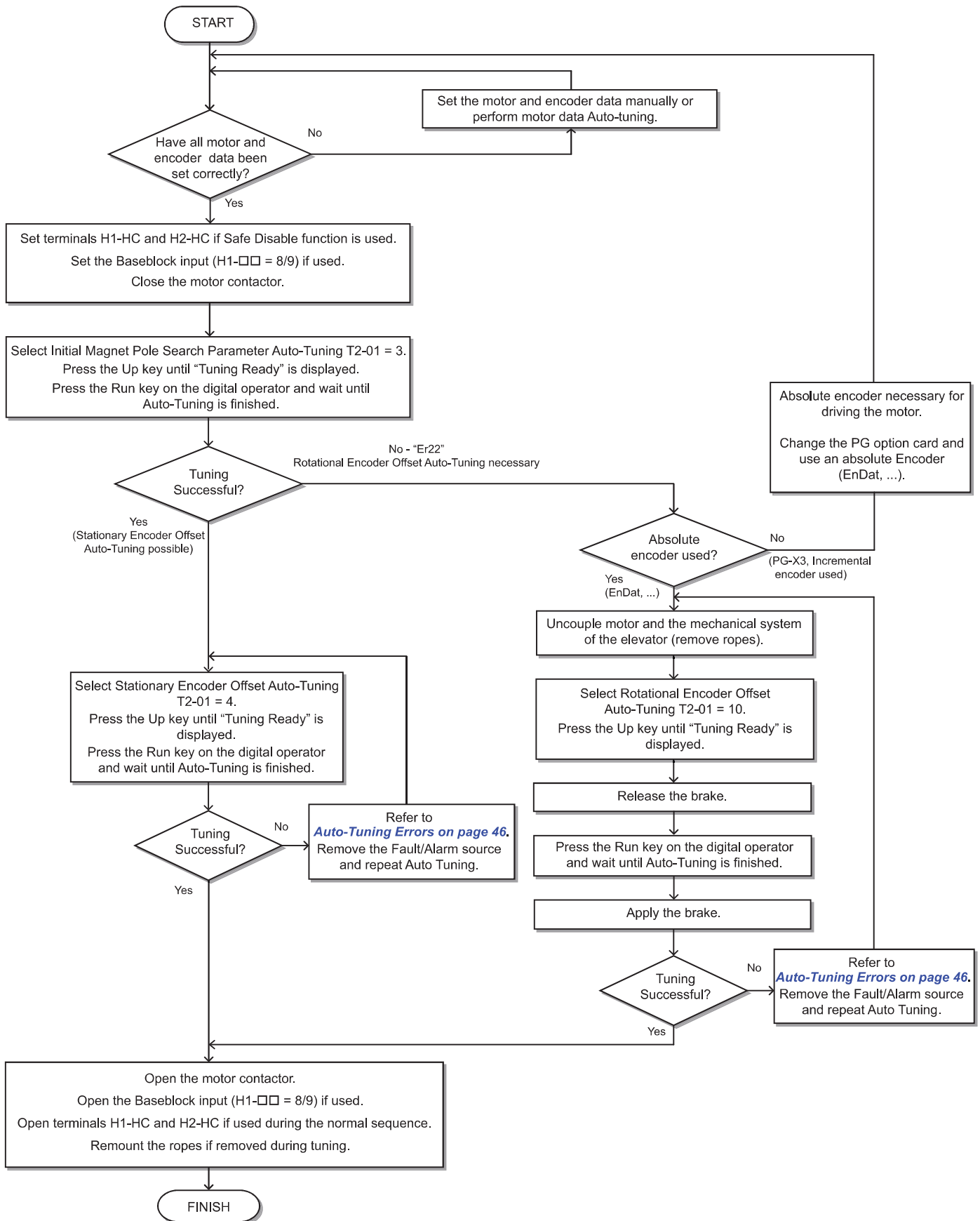

Note: When the first operation trial after non-rotating encoder tuning fails, e.g., due to wrong encoder rotation direction, repeat the encoder offset tuning after correcting the fault cause before starting a new trial.

◆ Up and Down Commands and Speed Reference Selection

■ Speed Reference Selection

Parameter b1-01 determines the source of the speed reference.

b1-01	Reference source	Speed Reference Input
0 (default)	Operator keypad (Digital inputs)	Set the speed references in the d1-□□ parameters and use digital inputs to switch over between different reference values.
1	Analog input <1>	Apply the speed reference signal to terminal A1 or A2.
2	Serial Communication <2>	Serial Communications using the RS422/485 port
3	Option Board <2>	Communications option card

<1> If source of the speed reference is assigned to the control terminals (b1-01 = 1), then d1-18 will automatically be set to 0 (so that the drive uses multi-speed references d1-01 to d1-08) by the drive's internal processing.

<2> If the speed reference selection in d1-18 is set so that either the high speed reference has priority (d1-18 = 1), or so that the leveling speed has priority (d1-18 = 2), then the drive will look to the multi-function input terminals for the speed reference.

■ Up / Down Command Source Selection

The input source for the Up and Down signal can be selected in parameter b1-02.

b1-02	Up/Down source	Up/Down Command Input
0	Operator keypad	RUN and STOP keys on the operator
1 (default)	Digital inputs	Terminal S1: Run in the Up direction Terminal S2: Run in the Down direction
2	Serial Communication	Serial Communications using the RS422/485 port
3	Option Board	Communications option card

■ Travel Start and Stop

Travel Start

To start the elevator in the up or down direction, the following conditions must be fulfilled:

- A speed reference greater than zero must be selected.
- The Safe Disable signals at terminals H1 and H2 must both be closed.
- An Up or Down Signal must be set at the source specified in b1-02.

Travel Stop

The drive stops under the following conditions:

- The Up or Down command is cleared.
- d1-18 is set to 1 or 2 and the Up/Down or Leveling Speed signal (H1-□□ = 53) is cleared.
- d1-18 is set to 3 and all speed inputs are cleared.
- A fault occurs. The stopping method depends on the fault occurred and certain parameter settings.
- The Safe Disable inputs are opened or a Base Block signal is input. In this case the brake is applied immediately and the drive output shuts off.

◆ **Speed Selection Using Digital Inputs (b1-01 = 0)**

Use parameter d1-18 to determine how different travel speeds are selected by digital inputs.

d1-18	Speed Selection
0	Multi-speed inputs 1, Speed references are set in d1-01 to d1-08
1 (default)	Separate speed inputs, Speed references are set in d1-19 to d1-24 and d1-26, Higher speed has priority
2	Separate speed inputs, Speed references are set in d1-19 to d1-24 and d1-26, Leveling speed has priority
3	Multi speed inputs 2, Speed references are set in d1-02 to d1-08, Stop if no speed selection input is enabled

■ **Multi-Speed Inputs 1, 2 (d1-18 = 0 or 3)**

Speed Selection

When d1-18 = 0 or 3, multi-function digital inputs are preset as shown below.

Terminal	Parameter Number	Set Value	Details
S5	H1-05	3	Multi-Step Speed Reference 1
S6	H1-06	4	Multi-Step Speed Reference 2
S7	H1-07	5	Multi-Step Speed Reference 3

Different speed reference settings can be selected by combining the three digital inputs as shown in the table below.

Digital Inputs			Selected Speed	
Multi-Step Speed Reference 1	Multi-Step Speed Reference 2	Multi-Step Speed Reference 3	d1-18 = 0	d1-18 = 3
0	0	0	Speed reference 1 d1-01	Stop
1	0	0	Speed reference 2 d1-02	Speed reference 2 d1-02
0	1	0	Speed reference 3 d1-03	Speed reference 3 d1-03
1	1	0	Speed reference 4 d1-04	Speed reference 4 d1-04
0	0	1	Speed reference 5 d1-05	Speed reference 5 d1-05
1	0	1	Speed reference 6 d1-06	Speed reference 6 d1-06
0	1	1	Speed reference 7 d1-07	Speed reference 7 d1-07
1	1	1	Speed reference 8 d1-08	Speed reference 8 d1-08

0 = Off, 1 = On

Setting d1-18 = 0

Eight separate speed settings (defined in parameters d1-01 to d1-08) can be selected by three digital input signals.

Setting d1-18 = 3

Seven separate speeds settings (defined in parameters d1-02 to d1-08) can be selected by three digital input signals. The drive stops when no speed is selected (i.e., all speed selection inputs are switched off).

■ **Separate Speed Inputs (d1-18 = 1 or 2)**

With this setting, six different speeds (defined in the parameters d1-19 to d1-24 and d1-26) can be set and selected using four digital inputs.

Speed Selection

When d1-18 = 1 or 2, Multi-function digital inputs are preset as shown below.

Terminal	Parameter Number	Set Value	Details
S3	H1-03	50	Nominal speed (d1-19)
S5	H1-05	51	Intermediate speed
S6	H1-06	53	Leveling speed (d1-26)

Depending on the assignment of speed selection functions to the digital input (H1-□□ settings), the different speed settings can be selected like shown in the table below.

Selected Speed	Leveling and Nominal Speed assigned (H1-□□ = 50 and H1-□□ = 53)				Leveling speed not assigned (H1-□□ ≠ 53)			Nominal Speed not assigned (H1-□□ ≠ 50)		
	50	51	52	53	50	51	52	51	52	53
Nominal Speed (d1-19)	1	0	0	A	1	0	0	0	0	0
Intermediate Speed 1 (d1-20)	0	1	0	A	0	1	0	1	0	0
Intermediate Speed 2 (d1-21)	1	1	1	A	1	1	1	N/A	N/A	N/A
Intermediate Speed 3 (d1-22)	0	1	1	A	0	1	1	1	1	0
Revelling Speed (d1-23)	0	0	1	A	0	0	1	0	1	0
Leveling Speed (d1-26)	0	0	0	1	0	0	0	X	X	1
Zero Speed	0	0	0	0	N/A	N/A	N/A	N/A	N/A	N/A

0 = Off, 1 = On

A: No influence when d1-18 = 1, 0 when d1-18 = 2

B: No influence

N/A = Not available

Higher Speed has Priority and the Leveling Speed Input is Assigned (d1-18 = 1 and H1-□□ = 53) (Default)

The higher speed has priority over the leveling speed, meaning the leveling signal is disregarded as long as any other speed selection input is active. The drive decelerates to the leveling speed (d1-26) when the selected speed reference signal is removed.

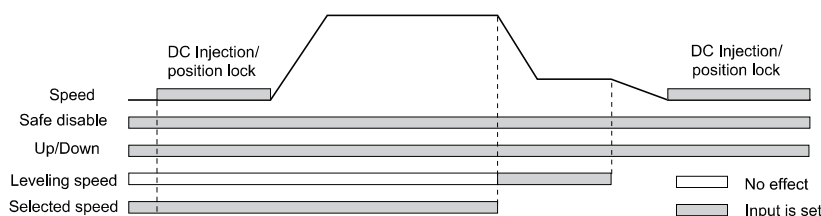

Higher Speed Priority is Selected and the Leveling Speed Input is Not Assigned (d1-18 = 1 and H1-□□ ≠ 53)

The drive decelerates to the leveling speed (d1-26) when the selected speed reference signal is removed.

If no speed reference is selected at start the drive will trigger an “FrL” fault. To disable Speed Reference Missing (FrL) detection, set parameter S6-15 to “0”. With this setting the drive starts using leveling speed if no other speed reference is selected.

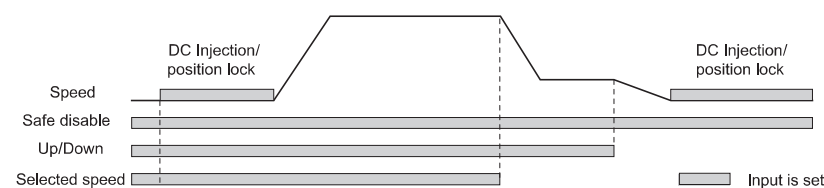

Leveling Speed has Priority and the Leveling Speed Input is Assigned (d1-18 = 2, H1-□□ = 53)

The leveling signal has priority over other speed references. The drive decelerates to the leveling speed (d1-26) when the leveling speed selection input is activated.

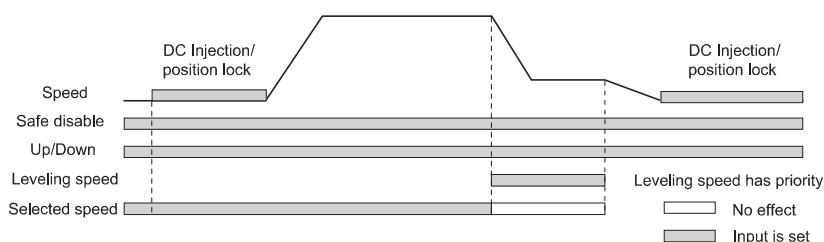

Leveling Speed Priority is Selected and the Nominal Speed Input is Not Assigned (d1-18 = 2, H1-□□ ≠ 50)

The drive runs at nominal speed (d1-19) when no speed selection input is set. When the leveling speed signal is set, the drive decelerates to the leveling speed. The leveling speed signal has priority over all other speed signals.

CAUTION! This sequence can be risky if the speed selection doesn't work for some reason (broken wire, etc.)

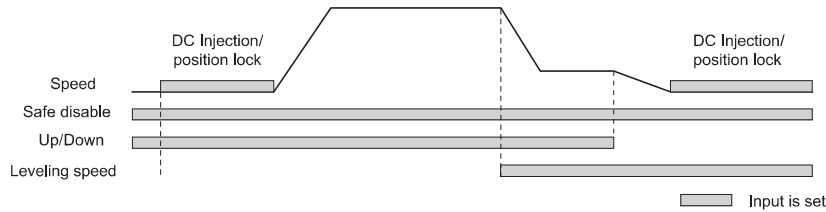

◆ I/O Signal Setup

Note: The default setting functions can be seen in the connection diagram on page 12.

■ Multi-Function Digital Inputs

Assign functions to each digital input terminal using the H1-□□ parameters.

■ Multi-Function Digital Outputs

Determine the function for each digital output terminal with the H2-□□ parameters. The setting value of these parameters consists of three digits, where the middle and right digit determines the function, and the left digit sets the output characteristics. The output characteristics can be either “Output as selected” (0) or “Inverse output” (1).

■ Multi-Function Analog Inputs

The function of each analog input can be assigned in the H3-□□ parameters.

■ Multi-Function Analog Outputs

Use the H4-□□ parameters to set up the output value of the analog monitor outputs and to adjust the output signal levels.

◆ Acceleration Ramp, Deceleration Ramp, and Jerk Settings

The acceleration and deceleration ramps are set in the parameters C1-01 and C1-02, while the jerk settings are set in the C2-□□ parameters as shown in the figure below.

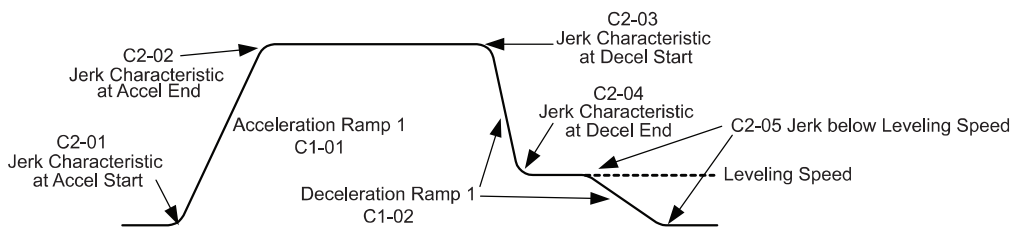

The way of setting these parameters and their setting units change with parameter o1-03 as shown below:

	o1-03 = 0, 1, 2, 3, 4	o1-03 = 5
Accel/Decel Ramps C1-□□	Set in units of second as the time to accelerate from zero to the rated speed, respectively as time to decelerate from rated speed to zero.	Set in units of m/s ² as accel/decel ramp used when changing the speed.
Jerk Settings C2-□□	Set in units of second as the time used to change the accel/decel ramp from zero to the accel/decel ramp setting of C1-□□ and vice versa.	Set in units of m/s ³ as the accel/decel change rate.

◆ Brake Sequence

The figure below shows the brake sequence and parameters that can be used for adjustment.

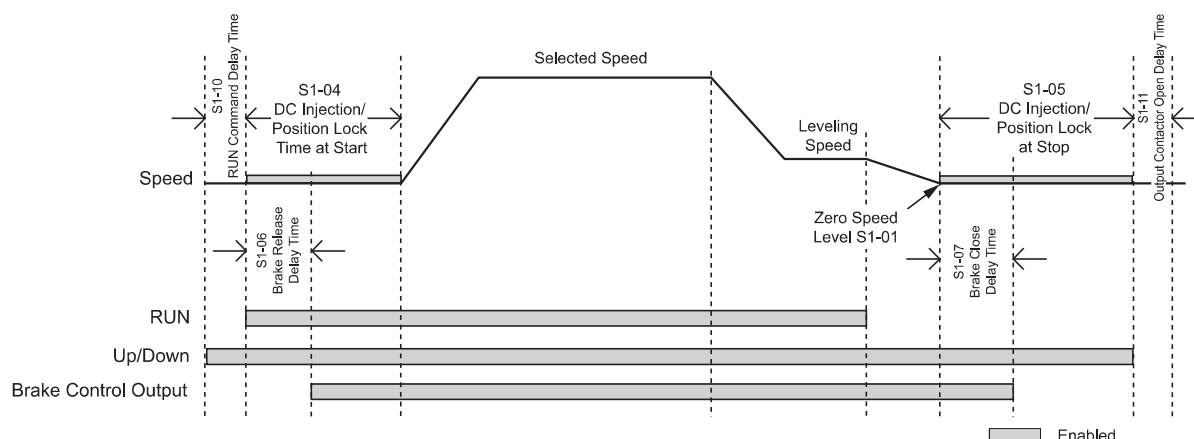

◆ Inspection Operation

■ Start in Inspection Mode

Inspection operation is performed when an Up or Down signal is input while one of the conditions below is true.

- Parameter d1-18 is set to 0 or 3 and the selected speed is higher than d1-28 but lower than d1-29.
- Parameter d1-18 is set to 1 or 2 and a digital input programmed for Inspection Operation Speed (H1-□□ = 54) is enabled.

The start is performed using the same acceleration characteristics, brake sequence and contactor sequence like in normal operation. The carrier frequency is set to 2 kHz during Inspection Operation but can be changed using parameter C6-21.

■ Stop in Inspection Mode

To stop the drive in Inspection Mode either remove the Up or Down signal or unselect the Inspection Operation Speed Reference (conditions listed for Start in Inspection Mode must become untrue).

The stop can be performed using a deceleration ramp, depending on the setting of parameter C1-15 (Inspection Operation Deceleration Ramp).

- If C1-15 = 0, the drive immediately applies the brake, shuts off the drive output and opens the motor contactor.
- If C1-15 > 0, the drive decelerates to stop, applies the brake, shuts the output off and opens the motor contactor.

6 Fine Adjustments

This section provides tips for improving the ride quality after the basic setup is complete and lists solutions to potential problems. Refer to the Technical Manual for detailed description.

◆ Potential Problems and Solutions

Problem	Control Mode and Possible Cause		Corrective Action
Rollback at start	V/f OLV	Not enough torque when the brake is released.	<ul style="list-style-type: none"> • Increase the DC Injection Braking current at start using parameter S1-02. • Increase the minimum (E1-10) and medium (E1-08) V/f pattern voltages. Make sure, that the starting and leveling current does not rise too high.
		DC Injection and brake timing not optimal.	Set the time for DC Injection Braking at start (S1-04) as short as possible, but make sure that brake releases completely before the motor starts to turn.
	OLV	The slip or torque compensation function acts too slowly.	<ul style="list-style-type: none"> • Decrease the torque compensation time C4-02. • Decrease the slip compensation time C3-02.
	CLV CLV/PM	The speed control is not responding fast enough when the brake is released.	Adjust the speed control loop parameters used during position lock. Increase C5-19 and reduce C5-20.
		The Position Lock control loop does not respond fast enough.	<ul style="list-style-type: none"> • Adjust the speed control loop parameters used during position lock. Increase C5-19 and reduce C5-20. • Increase the position lock gain at start 1 in S3-01 gradually. If vibration occurs reduce it. • Increase the position lock gain at start 2 in S3-02 gradually until rollback disappears.
	All	Motor torque is not fully established when the brake is released.	Lengthen the brake release delay time (S1-06) and the time for DC Injection Braking / Position Lock at start (S1-04).
Motor contactors close too late.		Make sure, that the contactors are closed before the Up/Down command is set or latest together with the Up/Down command.	
Shock at start	All	Motor starts turning when the brake is not completely released or runs against the brake.	Increase the DC Injection Braking time at start using parameter S1-04.
		Acceleration ramp is changing too quickly.	Decrease the Jerk at start. Decrease C2-01 if set in m/s ² , increase C2-01 if set in s.
		Rollback occurs during brake opening.	See above under “Rollback at start”.
Shock at stop	All	Brake is applied too early, causing the motor to run against the brake.	Increase the Delay Time to Close the Brake (S1-07). If necessary, also increase the DC Injection Braking time at stop S1-05.
		Motor contactor is released before the brake has fully applied.	Check the motor contactor sequence.
	CLV CLV/PM	Rollback occurs before the brake applies at stop.	<ul style="list-style-type: none"> • Make sure the speed control loop parameters for position lock are adjusted properly (C5-13 and C5-14). • Increase the position lock gain at stop S3-03 gradually until no rollback occurs anymore. If vibration occurs reduce the gain S3-03.
Jerk occurs due to overshoot when the motor reaches top speed.	OLV	Too fast torque compensation or slip compensation	<ul style="list-style-type: none"> • Increase the torque compensation delay time (C4-02). • Increase the slip compensation delay time (C3-02).
	CLV CLV/PM	Speed control Loop setting are too soft or too hard.	<ul style="list-style-type: none"> • Adjust the speed control loop gain C5-01 and integral time C5-02. • Adjust inertia compensation parameters (n5-□□) if only speed control loop settings cannot solve the problem.
		Wrong motor data	<ul style="list-style-type: none"> • For induction motors readjust the motor data (E2-□□), especially the slip (E2-02) and no-load current values (E2-03), or perform Auto-Tuning again. • For PM motors readjust the motor data in E5-□□ or perform Auto-Tuning.
		Inertia compensation function is not set up correctly.	If the inertia compensation function is used (n5-01 = 1) make sure the values in n5-02 and n5-03 are correct.
	All	The acceleration ramp changes too quickly when reaching the selected speed.	Decrease the jerk at the end of acceleration. Decrease C2-02 if set in m/s ² , increase C2-02 if set in s.

Problem	Control Mode and Possible Cause		Corrective Action
Motor stops shortly (undershoot) when the leveling speed is reached.	V/f OLV	Not enough torque at low speed	Increase the minimum and middle voltage levels for the V/f pattern voltage (E1-10 and E1-08 respectively). Make sure that the starting and leveling current does not rise too high.
	OLV CLV	Motor data incorrect	Adjust the motor data (E2-□□), especially the motor slip (E2-02) and no-load current values (E2-03), or perform Auto-Tuning.
		Too much slip compensation	
	CLV CLV/PM	Speed control loop responds too slow.	Increase the speed control gain and reduce the speed control integral time used for low speed at stop. The parameters to be changed depend on the setting of C5-05 and if a third set of speed loop settings is used or not. Refer to <i>Speed Loop Adjustments (CLV and CLV/PM) on page 36</i> .
		The inertia compensation function is not set up correctly.	If the inertia compensation function is used (n5-01=1) make sure the values in n5-02 and n5-03 are correct.
All	The deceleration ramp changes too quickly when reaching the leveling speed.	Decrease the Jerk at the end of deceleration. Decrease C2-04 if set in m/s ² , increase C2-04 if set in s.	
Motor speed overshoot at acceleration end and undershoot when reaching leveling speed occurs. Problem cannot be resolved by adjusting the speed loop.	CLV CLV/PM	Inertia is high.	Use the inertia compensation function. Set n5-01 to 1 and then adjust parameters n5-02 and n5-03 as described in <i>Inertia Compensation (CLV and CLV/PM) on page 36</i> .
Motor or machine vibrates at high speed or top speed.	OLV	Torque compensation is responding too quickly.	Increase the torque compensation delay time (C4-02).
	CLV CLV/PM	Speed control loop adjusted too hard.	Decrease C5-01, then increase C5-02.
Motor or machine vibrates in the low or medium speed range.	V/f	Output voltage is too high.	Reduce the V/f pattern settings (E1-08, E1-10).
	OLV	Torque compensation is responding too quickly.	Increase the torque compensation delay time (C4-02).
		Output voltage is too high.	Reduce the V/f pattern settings (E1-08, E1-10).
	OLV CLV	The value for the motor slip is set incorrectly.	Check the motor slip value in parameter E2-02. Increase or decrease it in steps of 0.2 Hz.
CLV CLV/PM	Speed control loop adjusted too hard.	<ul style="list-style-type: none"> Decrease C5-01 and then increase C5-02 if the problem occurs at speed higher than C5-07. Decrease C5-03 and then increase C5-04 if the problem occurs at speed lower than C5-07. Decrease C5-13 and then increase C5-14 if the problem occurs at speed lower than C5-07 but only during deceleration. 	
		<ul style="list-style-type: none"> If vibration occurs at during position lock at start, first decrease S3-02. If decreasing S3-02 does not resolve the problem, decrease S3-01. Decrease S3-03 if vibration occurs during position lock at stop. 	
Motor or machine vibrates in During Position Lock.	CLV CLV/PM	The Position Lock control loop does not respond fast enough.	Decrease C5-19 and then increase C5-20.
		The speed control is not responding quickly enough when the brake is released.	
Vibrations with the frequency equal to the motor speed occur.	CLV CLV/PM	Encoder vibrates.	Check the encoder mounting and the alignment of encoder and motor shaft.
	All	Mechanical problems	Check bearings and gearbox.
		Rotational parts (motor armature, handwheel, brake disk/drum) are not properly balanced.	Properly balance rotating parts.
Oscillations when using an analog speed reference.	All	The analog reference value is not stable or the signal is noisy.	<ul style="list-style-type: none"> Check the analog signal line connection. Use shielded twisted pair cables. Apply a filter to the analog input signal by setting parameter H3-13.
Top speed is different in motoring and regenerative mode.	OLV	Slip Compensation during Regenerative operation is switched off.	Make sure C3-04 is set properly and set parameter C3-05 to 0.

6 Fine Adjustments

Problem	Control Mode and Possible Cause		Corrective Action
Speed reference and motor speed do not match when using an analog reference signal.	All	The drives analog input is not set according to the signal level of the controller speed reference output signal.	Check the gain and bias settings for the analog input that is used to set the speed reference. Check parameters H3-03 and H3-04 for input A1, check parameters H3-11 and H3-12 for input A2.
Acceleration is longer than set to C1-□□ parameters.	All	The load is too high.	<ul style="list-style-type: none"> • Check if the acceleration ramp set is not too high (acceleration time is too short). • Make sure the drive rated current is enough to fulfill the application requirements. • Make sure the load does not stuck, car guide lubrication is ok, etc.
	V/f OLV	The load is too high and the current/torque exceeds the stall prevention level.	Check if the stall prevention level at acceleration in L3-03 is not set too small.
	OLV, CLV CLV/PM	The load is too high and the torque exceeds the drives torque limits.	Check if the torque limit parameters L7-□□ are not set too small.
Motor speed does not match the speed reference at constant speed.	All	The load is too high.	Make sure the drive rated current is enough to fulfill the application requirements.
	V/f	The load is too high and the current/torque exceeds the stall prevention level.	Check if the stall prevention level during run in L3-06 is not set too small.
	OLV, CLV CLV/PM	The load is too high and the torque exceeds the torque limits.	Check if the torque limit parameters L7-□□ are not set too small.
High frequency acoustic noise from the motor	All	The carrier frequency is too low.	Increase the carrier frequency in parameter C6-03. If the carrier frequency is set higher than the default setting, a current derating must be considered.

◆ Speed Loop Adjustments (CLV and CLV/PM)

The speed control loop uses three different gain and integral time settings that can be adjusted using C5-□□ parameters. The settings are switched over when the motor speed reaches the level set in parameter C5-07.

- Proportional gain and integral time C5-03/C5-04 are used at start when the speed is lower than the setting of C5-07.
- Proportional gain and integral time C5-01/C5-02 are used at speeds above the setting of C5-07.
- Proportional gain and integral time C5-13/C5-14 are used at stop when the speed is lower than the setting of C5-07.

Increase the gain and shorten the integral time to increase speed control responsiveness in each of the sections. Reduce the gain and increase the integral time if vibration or oscillation occurs.

◆ Inertia Compensation (CLV and CLV/PM)

Inertia compensation can be used to eliminate motor speed overshoot at the acceleration end or undershoot at the end of deceleration caused by the system inertia. Adjust the function following the steps below.

1. Make sure the speed control loop parameters are adjusted properly (C5-□□).
2. Set parameter n5-01 = 1 to enable inertia compensation.
3. Calculate and set n5-02 and n5-03 as follows:

Motor Acceleration Time n5-02	$n5-02 = J_{Mot} \cdot \frac{\pi \cdot n_{r_Mot}}{30 \cdot T_{r_Mot}}$	<ul style="list-style-type: none"> • J_{Mot} - Motor inertia in kgm^2 • n_{r_Mot} - Rated motor speed in min^{-1} • T_{r_Mot} - Rated motor torque in Nm
Inertia Compensation Gain n5-03	$\Sigma J = J_{TS} \cdot i^2 + \Sigma m \cdot \left(\frac{30 \cdot v_{r_Elev}}{\pi \cdot n_{r_Mot}} \right)^2$ $n5-03 = \Sigma J / J_{Mot}$	<ul style="list-style-type: none"> • J_{TS} - Traction sheave inertia in kgm^2 • i - Gear ratio (n_{Load}/n_{Mot}) • v_{r_Elev} - Rated elevator speed in m/s • Σm - Mass of all moved parts (car, counterweight, ropes, load <I>) in kg

<I> Insert 0 kg for the load to calculate the lowest setting, insert the elevator rated load to calculate the maximum setting for n5-03. Use the lower setting for initial trials.

4. Change the setting of n5-03 within the limits calculated in step 3 until the desired performance is achieved.

7 Parameter Table

This table below lists the most important parameters with default settings appearing in bold type. Refer to the Technical Manual for a complete list of parameters.

No.	Name	Description
Initialization Parameters		
A1-00	Language Selection	0: English 1: Japanese 2: German 3: French 4: Italian 5: Spanish 6: Portuguese 7: Chinese 8: Czech 9: Russian 10: Turkish 11: Polish 12: Greek Note 1. Language selection settings 8 to 12 can be selected from an LCD operator with version (REV) F or later. The version number of the LCD operator's PRG software is shown on the back of the digital operator. Note 2. Language selection settings 8 to 12 are available in drive software PRG: 7017 or later.
A1-01	Access Level Selection	0: View and set parameters A1-01 and A1-04 (U□-□□ parameters can also be viewed) 1: User Parameters (access to a set of parameters selected by the user, A2-01 to A2-32) 2: Advanced Access (access to view and set all parameters)
A1-02	Control Method Selection	0: V/f Control 2: Open Loop Vector Control 3: Closed Loop Vector Control 7: Closed Loop Vector Control for PM
A1-03	Initialize Parameters	0: No initialization 1110: User Initialize (parameter values must be stored using parameter o2-03) 2220: 2-wire initialization 5550: oPE04 error reset
Operation Mode Selection		
b1-01	Speed Reference Selection	0: Digital operator 1: Analog input terminals 2: MEMOBUS/Modbus communications 3: Option Card
b1-02	Up/Down Command Selection	0: Digital operator 1: Digital input terminals 2: MEMOBUS/Modbus communications 3: Option Card
b1-14	Phase Order Selection	Output phase order with an Up command. 0: U-V-W 1: U-W-V

No.	Name	Description
Acceleration/ Deceleration Ramps		
C1-□□	Acceleration/ Deceleration Ramps	These parameters set the acceleration and deceleration ramps. Setting units are determined by parameter o1-03. Refer to page 23.
C2-□□	Jerk Settings	These parameters adjust the Jerk settings. Setting units are determined by parameter o1-03. Refer to page 23.
Slip Compensation		
C3-01	Slip Compensation Gain	<ul style="list-style-type: none"> Increase C3-01 if motor slip requires more compensation (motor speed is lower than speed reference). Decrease if slip is overcompensated.
C3-02	Slip Compensation Primary Delay Time	<ul style="list-style-type: none"> Decrease if the drive does not provide motor slip compensation quickly enough. Increase if motor oscillation occurs.
Speed Control Loop Settings		
C5-01	Speed Control Loop Gain 1	Set the speed control loop responsiveness at high speed.
C5-02	Speed Control Loop I Time 1	
C5-03	Speed Control Loop Gain 2	Set the speed control loop responsiveness at low speed during start.
C5-04	Speed Control Loop I Time 2	
C5-07	Speed Control Settings Switching Speed	Sets the switching speed for speed loop settings.
C5-13	Speed Control Loop Gain 3	Set the speed control loop responsiveness at low speed during stop.
C5-14	Speed Control Loop I Time 3	
Carrier Frequency		
C6-03	Carrier Frequency	Sets the carrier frequency. Settings above the default requires output current derating.
Speed Reference		
d1-01 to d1-08	Speed Reference 1 to 8	Speed reference values for multi-speed inputs. Setting units are determined by parameter o1-03. Refer to page 23.
d1-18	Speed Reference Selection Mode	0: Multi-speed references 1 to 8 1: Higher speed reference has priority 2: Leveling speed reference has priority 3: Multi-Speed References 2 to 8 (with Multi-speed 1 selected the drive stops)

7 Parameter Table

No.	Name	Description
d1-19	Nominal Speed	Speed reference values for separate speed selection inputs. Setting units are determined by parameter o1-03. Refer to page 23.
d1-20	Intermediate Speed 1	
d1-21	Intermediate Speed 2	
d1-22	Intermediate Speed 3	
d1-23	Relevel. Speed	
d1-24	Inspection Operation Speed	
d1-26	Leveling Speed	
d1-28	Leveling Speed Detection Level	Used when d1-18 = 0 or 3. If the speed reference selected is lower than d1-28, then the drive uses the leveling speed as the speed reference.
d1-29	Inspection Speed Detection Level	Used when d1-18 = 0 or 3. If the speed reference selected is between d1-28 and d1-29, then the speed reference is regarded as the Inspection Speed, and the inspection operation sequence is activated.
V/f Pattern		
E1-01	Input Voltage Setting	This parameter must be set to the power supply voltage. WARNING! Drive input voltage (not motor voltage) must be set in E1-01 for the protective features of the drive to function properly.
E1-04	Maximum Output Frequency	<p>V/f pattern settings</p> <p>Output Voltage (V)</p> <p>Frequency (Hz)</p>
E1-05	Maximum Voltage	
E1-06	Base Frequency	
E1-07	Mid Output Frequency	
E1-08	Mid Output Voltage	
E1-09	Minimum Output Frequency	
E1-10	Minimum Output Voltage	
E1-13	Base Voltage	Parameters must be set so that: $E1-09 \leq E1-07 < E1-06 \leq E1-04$
Motor Parameters		
E2-01	Rated Current	Motor data for Induction Motors.
E2-02	Rated Slip	
E2-03	No-Load Current	
E2-04	Motor Poles	
E2-05	Line-to-Line Resistance	
E2-06	Leakage Inductance	

No.	Name	Description
PM Motor Settings		
E5-02	Rated Power	Motor data for permanent magnet motors.
E5-03	Rated Current	
E5-04	Motor Poles	
E5-05	Stator Resistance	E5-09 is set as peak-to-peak value for one motor phase in units of 0.1 mVs/rad (electrical angle).
E5-06	d-Axis Inductance	E5-24 is set as phase-to-phase RMS value in units of 0.1 mVmin (mechanical angle).
E5-07	q-Axis Inductance	
E5-09	Induction Volt. Const. 1	If a value is set to E5-09, then E5-24 must be set to 0.0 and vice versa.
E5-24	Induction Volt. Const. 2	
PG Speed Control Card		
F1-01	Encoder 1 Resolution	Sets the encoder resolution.
F1-05	Encoder 1 Rotation Direction	0: A phase leads B in up direction 1: B phase leads A in up direction
F1-50	Encoder Selection	0: EnDat 2.1/01, 2.2/01 Serial Communication + Sin/Cos 1: EnDat 2.2/22 Serial Communication 2: HIPERFACE
F1-52	Communication Speed of Serial Encoder Selection	0: 1M bps/9600 bps 1: 500k bps/19200 bps 2: 1M bps/38400 bps 3: 1M bps/38400 bps
Multi-Function Digital Inputs / Outputs		
H1-03 to H1-08	Terminal S3 to S8 Function Selection	Selects the function of terminals S3 to S8.
H2-01 to H2-03	Terminal M1-M6 Function Selection	Sets the function for the relay outputs M1-M2, M3-M4, and M5-M6.
H2-04, H2-05	Terminal P1-C1, P2-C2 Function Sel.	Sets the function for the photocoupler outputs P1-C1 and P2-C2.
Note: Major functions are listed at the end of the table.		
Multi-Function Analog Inputs		
H3-01, H3-09	Terminal A1, A2 Signal Level Sel.	0: 0 to 10 V 1: -10 to 10 V
H3-02, H3-10	Terminal A1, A2 Function Selection	0: Speed bias 2: Auxiliary speed 1 3: Auxiliary speed 2 14: Torque compensation 1F: Through mode
H3-03, H3-11	Terminal A1, A2 Gain Setting	Sets the level of the input value selected in H3-02 and H3-10 when 10 V is input at terminals A1 and A2.
H3-04, H3-12	Terminal A1, A2 Bias Setting	Sets the level of the input value selected in H3-02 and H3-10 when 0 V is input at terminals A1 and A2.
Multi-Function Analog Outputs		
H4-01, H4-04	Terminal FM, AM Monitor Selection	Selects the data to be output through multi-function analog output terminals FM and AM.
H4-02, H4-05	Terminal FM, AM Gain	Sets the signal level for terminals FM and AM that are equal to 100% of the monitor output that has been selected.

No.	Name	Description
H4-03, H4-06	Terminal FM, AM Bias	Sets the signal level for terminals FM and AM that are equal to 0% of the monitor value.
H4-07, H4-08	Terminal FM, AM Signal Sel.	0: 0 to 10 V 1: -10 to 10 V
Motor Protection		
L1-01	Motor Overload Protection Selection	0: Disabled 1: General purpose motor (self-cooled) 2: Drive dedicated motor with a speed range of 1:10 3: Vector motor with a speed range of 1:100 5: PM motor with constant torque control
Inertia Compensation Control		
n5-01	Inertia Compensation Selection	0: Disabled 1: Enabled
n5-02	Motor Acceleration Time	Sets the time the motor needs to accelerate from 0 to the nominal speed at 100% torque.
n5-03	Inertia Compensation Control Gain	Sets the gain used for inertia compensation. This value defines the ratio between motor and load inertia.
Digital Operator Display Selection		
o1-03	Digital Operator Display Unit Selection	0: 0.01 Hz 1: 0.01% 2: r/min 4: Elevator units 1 (speed = m/s, accel/decel ramp = s, Jerk = s) 5: Elevator units 2 (speed = m/s, accel/decel ramp = m/s ² , Jerk = m/s ³) Note: If o1-03 = 4 or 5, then parameters o1-20, o1-21, and o1-22 must also be set.
o1-20	Traction Sheave Diameter	Set the traction sheave diameter in mm.
o1-21	Roping Ratio	1: 1:1 2: 1:2 3: 1:3 4: 1:4
o1-22	Gear Ratio	Set the gear ratio of the mechanical gear.
Brake Sequence		
S1-01	Zero Speed Level at Stop	Sets the speed to close the brake at stop.
S1-02	DC Injection Current at Start	Adjusts the torque to hold the motor at zero speed during start and stop. Increase if roll-back occurs.
S1-03	DC Injection Current at Stop	
S1-04	DC Inj./ Position Lock Time at Start	Sets the time between the Up/Down command and acceleration start.
S1-05	DC Inj./ Position Lock Time at Stop	Sets the time between reaching the Zero Speed Level and when the drive output shuts off.
S1-06	Brake Release Delay Time	Sets the wait time between the Up/Down command and the brake release command.
S1-07	Brake Close Delay Time	Sets the wait time between reaching Zero Speed and the brake close command.
S1-12	Motor Contactor Control during Auto-Tuning	Sets the state of the output contactor control command (H2-□□ = 51) during Auto-Tuning.

No.	Name	Description
Slip Compensation for Elevators		
S2-01	Motor Rated Speed	Sets the motor rated speed in r/min.
S2-02/ S2-03	Slip Compensation Gain Motoring /Regen. Mode	Set the slip compensation gain for motoring operation (S2-02) and during regenerative operation (S2-03).
Start/Stop Optimization		
S3-01	Position Lock Gain at Start 1	Sets the gain for maintaining Zero Speed at start. Adjust the value so that no vibration occurs during Zero Speed at start.
S3-02	Position Lock Gain at Start 2	Used to prevent roll-back. Increase if roll-back occurs and S3-01 has already been set.
S3-03	Position Lock Gain at Stop	Sets the gain for maintaining Zero Speed at stop. Adjust the value so that no vibration occurs during Zero Speed at stop.
Short Floor Operation		
S5-01	Short Floor Operation Selection	0: Disabled 1: Enabled (Short Floor Operation) 2: Enabled (Advanced Short Floor Operation)
Induction Motor Auto-Tuning		
T1-01	Auto-Tuning Mode Selection	0: Rotational Auto-Tuning 1: Stationary Auto-Tuning 1 2: Stationary Auto-Tuning for Line-to-Line Resistance 4: Stationary Auto-Tuning 2 10: Inertia Tuning
T1-02	Motor Rated Power	Sets the motor rated power as specified on the motor nameplate.
T1-03	Motor Rated Voltage	Sets the motor rated voltage as specified on the motor nameplate.
T1-04	Motor Rated Current	Sets the motor rated current as specified on the motor nameplate.
T1-05	Motor Base Frequency	Sets the rated frequency of the motor as specified on the motor nameplate.
T1-06	Number of Motor Poles	Sets the number of motor poles as specified on the motor nameplate.
T1-07	Motor Base Speed	Sets the rated speed of the motor as specified on the motor nameplate.
T1-08	Encoder Resolution	Set the number of pulses per revolution for the encoder being used.
T1-09	Motor No-Load Current	Sets the no-load current and rated slip for the motor. Automatically calculated after setting the T1-02 and T1-04. If know enter the no-load current and slip as indicated on the motor test report. If not, proceed with shown values.
T1-10	Motor Rated Slip	

7 Parameter Table

No.	Name	Description
PM Motor Auto-Tuning		
T2-01	Auto-Tuning Mode Selection	0: Motor Data input 1: Stationary Auto-Tuning 2: Stationary stator resistance Auto-Tuning 3: Initial magnet pole search parameters Auto-Tuning 4: Stationary encoder offset Auto-Tuning 10: Rotational encoder offset Auto-Tuning 11: Rotational back EMF constant Auto-Tuning 12: Auto-Tuning of PG-E3 encoder characteristics Setting 12 is available in drive software versions PRG: 7017 or later. Auto-Tuning of PG-E3 encoder characteristics requires a PG-E3 option with software version 1102 or later. To identify the PG-E3 software version, refer to the PG-E3 labeling on the option, in the field designated "C/N" (S + four digit number).
T2-04	Motor Rated Power	Sets the motor rated power as specified on the motor nameplate.
T2-05	Motor Rated Voltage	Sets the motor rated voltage as specified on the motor nameplate.
T2-06	Motor Rated Current	Sets the motor rated current as specified on the motor nameplate.
T2-08	Number of Motor Poles	Sets the number of motor poles as specified on the motor nameplate.
T2-09	Motor Base Speed	Sets the rated speed of the motor as specified on the motor nameplate.
T2-10	1 Phase Stator Resistance	Sets the 1-phase resistance of the stator winding in ohms.
T2-11	d-axis Inductance	Sets the d-axis inductance in mH.
T2-12	q-axis Inductance	Sets the q-axis inductance in mH.
T2-13	Induced Voltage Unit	0: mV/min ⁻¹ 1: mVs/rad
T2-14	Induced Voltage Const.	Sets the induced voltage (back EMF) constant.
T2-16	Encoder Resolution	Sets the encoder resolution.
T2-17	Encoder Offset	Sets the encoder offset.

Monitor	Description
Operation Status Monitor	
U1-01	Speed Reference (%)
U1-02	Output Speed (%)
U1-03	Output Current (A)
U1-05	Motor Speed (%)
U1-06	Output Voltage Reference (Vac)
U1-07	DC Bus Voltage (Vdc)
U1-08	Output Power (kW)
U1-09	Torque Reference (% of motor rated torque)

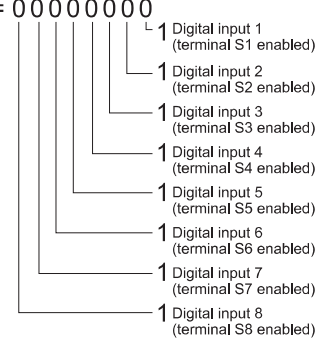
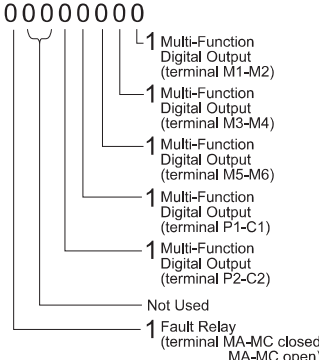
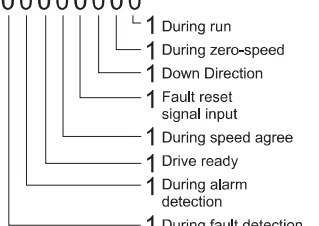
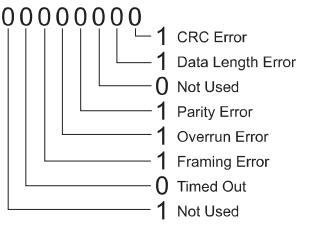
Monitor	Description
U1-10	Displays the input terminal status. U1-10 = 00000000  <ul style="list-style-type: none"> 1 Digital input 1 (terminal S1 enabled) 1 Digital input 2 (terminal S2 enabled) 1 Digital input 3 (terminal S3 enabled) 1 Digital input 4 (terminal S4 enabled) 1 Digital input 5 (terminal S5 enabled) 1 Digital input 6 (terminal S6 enabled) 1 Digital input 7 (terminal S7 enabled) 1 Digital input 8 (terminal S8 enabled)
U1-11	Displays the output terminal status. U1-11 = 00000000  <ul style="list-style-type: none"> 1 Multi-Function Digital Output (terminal M1-M2) 1 Multi-Function Digital Output (terminal M3-M4) 1 Multi-Function Digital Output (terminal M5-M6) 1 Multi-Function Digital Output (terminal P1-C1) 1 Multi-Function Digital Output (terminal P2-C2) Not Used 1 Fault Relay (terminal MA-MC closed MA-MC open)
U1-12	Verifies the drive operation status. U1-12 = 00000000  <ul style="list-style-type: none"> 1 During run 1 During zero-speed 1 Down Direction 1 Fault reset signal input 1 During speed agree 1 Drive ready 1 During alarm detection 1 During fault detection
U1-13	Terminal A1 Input Voltage
U1-14	Terminal A2 Input Voltage
U1-16	Output Speed after Soft Starter
U1-18	oPE Fault Parameter
U1-19	Displays the contents of a MEMOBUS/Modbus error. U1-19 = 00000000  <ul style="list-style-type: none"> 1 CRC Error 1 Data Length Error 0 Not Used 1 Parity Error 1 Overrun Error 1 Framing Error 0 Timed Out 1 Not Used
Fault Trace	
U2-01	Current Fault
U2-02	Previous Fault
U2-03	Speed Reference at Previous Fault
U2-04	Output Speed at Previous Fault
U2-05	Output Current at Previous Fault
U2-06	Motor Speed at Previous Fault
U2-07	Output Voltage at Previous Fault
U2-08	DC Bus Voltage at Previous Fault
U2-09	Output Power at Previous Fault

Monitor	Description
U2-10	Torque Reference at Previous Fault
U2-11	Input Terminal Status at Previous Fault
U2-12	Output Terminal Status at Previous Fault
U2-13	Drive Operation Status at Previous Fault
U2-14	Cumulative Operation Time at Previous Fault
U2-15	Soft Starter Output at Previous Fault
U2-16	Motor q-Axis Current at Previous Fault
U2-17	Motor d-Axis Current at Previous Fault
U2-20	Heatsink Temperature at Previous Fault
Fault History	
U3-01 to U3-04	First to 4th Most Recent Fault
U3-05 to U3-10	5th to 10th Most Recent Fault
U3-11 to U3-14	Cumulative Operation Time at 1st to 4th Most Recent Fault
U3-15 to U3-20	Cumulative Operation Time at 5th to 10th Most Recent Fault
Note: The following faults are not recorded in the error log: CPF00, CPF01, CPF02, CPF03, Uv1, and Uv2.	
Fault Trace	
U4-01	Cumulative Operation time
U4-24	Number of travels (lower 4 digits)
U4-25	Number of travels (upper 4 digits)
U4-26	Maximum Current during Acceleration
U4-27	Maximum Current during Deceleration
U4-28	Maximum Current during Constant Speed
U4-29	Maximum Current during Leveling Speed
DI/DO Sel.	Description
Digital Input Function Selections	
3	Multi-step speed reference 1
4	Multi-step speed reference 2
5	Multi-step speed reference 3
F	Not used (through mode)
14	Fault reset (Reset when turned ON)
20 to 2F	External fault; Input mode: N.O. contact / N.C. contact Detection mode: Normal/during operation
50	Nominal speed (d1-19)
51	Intermediate speed
52	Releveling speed (d1-23)
53	Leveling speed (d1-26)
54	Inspection operation
56	Motor contactor feedback
79	Brake feedback
Digital Output Function Selections	
0	During Run (ON: Run command is ON or voltage is being output)
6	Drive Ready
E	Fault
F	Not used (through mode)
50	Brake Control
51	Output Contactor Control
58	Safe Disable Status

8 Troubleshooting

◆ General Fault and Alarms

Faults and alarms indicate problems in the drive or in the machine.

The drive indicates that an alarm has occurred with a code on the data display screen and a flashing ALM LED. The drive output may be shut off depending on the alarm.

The drive indicates that a fault has occurred with a code on the data display screen and a lit ALM LED. The drive output is always switched off immediately and the motor coasts to stop.

To remove an alarm or reset a fault, first figure out what cause the problem, take corrective action, and finally reset the drive by pushing the RESET key on the operator or by cycling the power supply.

The table below lists the most important alarms and faults only. Please refer to the Technical Manual for a complete list.

Digital Operator	AL	FLT	Possible Cause	Corrective Action
Drive Baseblock <i>b̄b̄</i> (bb)	○		The software baseblock function is assigned to one of the digital inputs and the input is off. The drive does not accept Up/Down commands during this time.	<ul style="list-style-type: none"> • Check the functions assigned to the digital input terminals. • Check the upper controller sequence.
Control Fault <i>ĈF</i> (CF)		○	The torque limit was reached during deceleration for longer than 3 s and one of the following was true: <ul style="list-style-type: none"> • the load inertia is too big. • the torque limit is too low. • the motor parameters are set incorrectly. 	<ul style="list-style-type: none"> • Check the load. • Set the torque limit to the most appropriate setting (L7-01 through L7-04). • Check the motor parameters settings.
Control Circuit Fault <i>ĈPF02</i> (CPF02) to <i>ĈPF25</i> (CPF25)		○	There is a problem in the drive's control circuit.	<ul style="list-style-type: none"> • Cycle the drive power supply. • Initialize the drive. • Replace the drive if the fault occurs again.
A/D Conversion Error <i>ĈPF35</i> (CPF35)		○	An A/D conversion error or control circuit error occurred.	<ul style="list-style-type: none"> • Cycle power to the drive. • Replace the control board or the entire drive if the problem continues.
Cannot Reset <i>Ĉr5r</i> (CrST)	○		Fault reset was input when the Up or Down command was active.	Turn off the Up and Down command and reset the drive.
Speed Deviation (for Control Mode with Encoder) <i>dĒv</i> (dEv)		○	F1-04 is set to 0, 1, or 2 and a speed deviation higher than the value in F1-10 occurred longer than the time set in F1-11.	<ul style="list-style-type: none"> • Reduce the load. • Decrease the acceleration and deceleration ramp. • Check the mechanical system (lubrication, etc.) • Check the setting of F1-10 and F1-11. • Check the brake sequence to make sure the brake is fully open when acceleration starts.
Rotation Direction Fault <i>d̄v3</i> (dv3)		○	A speed deviation higher than 30% occurred while the torque reference and acceleration direction are opposite.	<ul style="list-style-type: none"> • Check the encoder wiring. • Verify the encoder rotation direction. Perform an offset tuning. • Reduce the load. • Check the brake sequence.
Rotation Direction Fault <i>d̄v4</i> (dv4)		○	Motor speed and speed reference directions are opposite and a deviation larger than set in F1-19 occurs.	<ul style="list-style-type: none"> • Verify the encoder direction. • Perform an encoder tuning. • Check the brake sequence.
Overacceleration Detection <i>d̄v6</i> (dv6)		○	The car acceleration is higher than the value set in parameter S6-10 for longer than the time set in S6-17.	<ul style="list-style-type: none"> • Check the settings of o1-20, o1-21, and o1-22. • Adjust acceleration and deceleration ramps. • Check the value set to S6-10 is not too small.
PM Rotor Position Estimation Error <i>d̄v8</i> (dv8)		○	<ul style="list-style-type: none"> • An invalid value resulted from Initial Pole Search. • The encoder rotation direction setting in parameter F1-05 has been changed and the motor is started without repeating the encoder offset tuning before. 	<ul style="list-style-type: none"> • Repeat the setup process, or perform Stationary Auto-Tuning or Initial Pole Search Auto-Tuning. • Check the brake sequence. The brake should remain applied during Initial Pole Search and whenever the power supply is interrupted. • Use a PG option card that is compatible with both L1000A and an absolute encoder.
Up/Down Command Error <i>ĈF</i> (EF)	○		The Up and Down command were input simultaneously for longer than 500 ms.	Check the sequence and make sure that the Up and Down command are not enabled at the same time.

Digital Operator	AL	FLT	Possible Cause	Corrective Action
External Faults (input terminal S3 to S8) <i>EF03</i> (EF03) to <i>EF08</i> (EF08)	○	○	<ul style="list-style-type: none"> An external fault was triggered by an external device via one of the digital inputs (S3 to S8). The digital inputs are set incorrectly. 	<ul style="list-style-type: none"> Find out why the device tripped the EF. Remove the cause and reset the fault. Check the functions assigned to the digital inputs.
Speed Reference Missing <i>FrL</i> (FrL)		○	Parameter d1-18 is set to 1, leveling speed detection is not assigned to a digital input (H1-□□ ≠ 53) and no speed was selected while an Up or Down command was entered.	<ul style="list-style-type: none"> Check the speed selection inputs. Check the sequence. Make sure the speed is selected before the Up or Down command is input.
Ground Fault <i>Gf</i> (GF)		○	<ul style="list-style-type: none"> Ground leakage current has exceeded 50% of the drives rated output current. Cable or motor insulation is broken. Excessive stray capacitance at drive output. 	<ul style="list-style-type: none"> Check the output wiring and the motor for short circuits or broken insulation. Replace any broken parts. Reduce the carrier frequency.
Safe Disable <i>Hbb</i> (Hbb)	○		Both Safe Disable inputs are open. The drive output is safely disabled and the motor cannot be started.	<ul style="list-style-type: none"> Check why the upper controller's safety device disabled the drive. Remove the cause and restart. Check the wiring. Terminals HC, H1, and H2 must be linked if the Safe Disable function is not utilized.
Safe Disable Circuit Fault <i>HbbF</i> (HbbF)	○		<p>Drive output is disabled while only one of the Safe Disable inputs is open (normally both input signals H1 and H2 should be open).</p> <ul style="list-style-type: none"> One channel is internally broken and does not switch off, even if the external signal is removed. Only one channel is switched off by the upper controller. 	<ul style="list-style-type: none"> Check the wiring from the upper controller and make sure that both signals are handled correctly. If the signals are set correctly and the alarm does not disappear, replace the drive.
Output Phase Loss <i>Lf</i> (LF)		○	<ul style="list-style-type: none"> Output cable is disconnected or the motor winding is damaged. Drive output wires are loose. Motor is too small (less than 5% of drive current). 	<ul style="list-style-type: none"> Check the power supply. Make sure that all cables are properly connected to the correct terminals.
Overcurrent <i>oC</i> (oC)		○	<ul style="list-style-type: none"> Short-circuit or ground fault on the drive output side. The drive is damaged. The load is too heavy. The acceleration or deceleration ramps are too short. The overcurrent level has exceeded the value set to L8-27. (PM control modes) Incorrect motor data or V/f pattern settings. The motor contactor was switched while the drive was running. 	<ul style="list-style-type: none"> Check the output wiring and the motor for short circuits or broken insulation. Replace the broken parts. Check the machine for damages (gears, etc.) and repair any broken parts. Check the drive output side short circuit for broken output transistor. <ul style="list-style-type: none"> B1 and U/V/W – (negative) and U/V/W Contact your Yaskawa representative or nearest Yaskawa sales office. Make sure the brake fully opens. Check accel/decel settings in C1-□□ and C2-□□. Correct the value set to overcurrent detection gain (L8-27). Check V/f pattern settings in E1-□□ (E3-□□ for motor 2). Check the output contactor sequence.
Encoder Communication Data Error <i>oFC53</i> (oFC53)		○	<ul style="list-style-type: none"> Encoder power supply voltage wrong. Wrong encoder type. Wrong wiring. 	<ul style="list-style-type: none"> Check the encoder power supply setting on the option card. Check the encoder wiring, especially the serial signal wires.
Encoder Error <i>oFC54</i> (oFC54)		○	<ul style="list-style-type: none"> Noise on the encoder signal. Bad wiring. 	Check the encoder wiring and make sure the encoder cable shield is properly grounded.
Heatsink Overheat <i>oH</i> (oH) or <i>oH1</i> (oH1)	○	○	<ul style="list-style-type: none"> Surrounding temperature is too high. The cooling fan has stopped. The heatsink is dirty. The airflow to the heatsink is restricted. 	<ul style="list-style-type: none"> Check the surrounding temperature and install cooling devices if necessary. Check the drive cooling fan. Clean the heatsink. Check the airflow around the heatsink.
Motor Overload <i>oL1</i> (oL1)		○	<ul style="list-style-type: none"> The motor load is too heavy. Acceleration and deceleration cycle times are too short. Value set for the motor rated current is incorrect. 	<ul style="list-style-type: none"> Check the elevator mechanics. Check the sequence. Check the rated current setting.

8 Troubleshooting

Digital Operator	AL	FLT	Possible Cause	Corrective Action
Drive Overload oL2 (oL2)		○	<ul style="list-style-type: none"> The load is too heavy. The drive is too small. Too much torque at low speed. 	<ul style="list-style-type: none"> Check the load. Make sure that the drive is big enough to handle the load. The overload capability is reduced at low speeds. Reduce the load or increase the drive size.
DC Bus Overvoltage ov (ov)	○	○	<ul style="list-style-type: none"> DC bus voltage rose too high. Braking transistor is too small. Braking chopper or resistor is broken. Unstable motor control in OLV. Input voltage is too high. 	<ul style="list-style-type: none"> Make sure the braking resistor and braking chopper are working correctly. Check motor parameter settings and adjust torque and slip compensation as needed. Make sure that the power supply voltage meets the drives specifications.
Over Speed oS (oS)		○	F1-03 is set to 0, 1, or 2 and the motor speed exceeded the value of F1-08 for longer than the time set in F1-09.	<ul style="list-style-type: none"> Check and adjust the speed control loop settings (C5-□□). If an external speed reference signal (analog, etc.) is used make sure the signal is ok. Check the settings of F1-08 and F1-09.
	○	○	F1-03 is set to 3 and the motor speed exceeded the value of F1-08 for longer than the time set in F1-09.	
Input Phase Loss PF (PF)		○	<ul style="list-style-type: none"> Input voltage drop or phase imbalance. One of the input phases is lost. Drive input wire are loose. 	<ul style="list-style-type: none"> Check the motor wiring. Make sure all terminal screws in the drive and motor are properly tightened. Check the motor and drive capacity.
Encoder Disconnected (for Control Mode with Encoder) PGo (PGo)		○	F1-02 is set to 0, 1, or 2 and no signal is received from the encoder for longer than the time set in F1-14.	<ul style="list-style-type: none"> Check the encoder wiring and fix it if needed. Check the encoder power supply. Check the command sequence. Check if the brake fully opens before acceleration starts.
	○	○	F1-02 is set to 3 and no signal is received from the encoder for longer than the time set in F1-14.	
Braking Resistor Fault rF (rF)		○	<ul style="list-style-type: none"> The proper braking resistor option has not been installed. Regenerative converter, regenerative unit, or braking unit is being used. 	<ul style="list-style-type: none"> Select the braking resistor option so that fits to the drives braking transistor specification. Disable the braking transistor protection selection (set L8-55 to 1).
Internal Braking Transistor Fault rr (rr)		○	The internal braking transistor is defective or the braking resistor is connected wrong.	<ul style="list-style-type: none"> Make sure the braking resistor is connected correctly. Cycle the power supply. Replace the drive if the fault reoccurs.
Motor Switch during Run rUn (rUn)		○	A motor switch command was entered during run.	Change the operation pattern so that the motor switch command is entered while the drive is stopped.
IGBT Short Circuit SC (SC)		○	<ul style="list-style-type: none"> The motor has been damaged due to overheating or the motor insulation is damaged. One of the motor cables has shorted out or there is a grounding problem. The drive is damaged. 	<ul style="list-style-type: none"> Check the insulation resistance. Check the wiring to the motor. Turn the power supply off and then on again to check operation. Check the drive output side short circuit for broken output transistor. <ul style="list-style-type: none"> B1 and U/V/W – (negative) and U/V/W <p>Contact your Yaskawa representative or nearest Yaskawa sales office.</p>
Safety Circuit Fault SCF (SCF)		○	The safety circuit is damaged.	If the problem continues, replace the control board or the entire drive. Contact Yaskawa or a Yaskawa representative for instructions on replacing the control board.
Motor Contactor Response Error SE1 (SE1)		○	The motor contactor response was not input within the time set in S1-10.	<ul style="list-style-type: none"> Make sure the motor contactor really closes. Check the setting of S1-10. Check the motor contactor feedback wiring.
Starting Current Error SE2 (SE2)		○	The output current was lower than 25% of the motor no-load current at start.	<ul style="list-style-type: none"> Check the motor wiring. Check the motor contactor and the contactor sequence. Make sure it closes properly during start.
Output Current Error SE3 (SE3)		○	The output current was lower than 25% of the motor no-load current during operation.	<ul style="list-style-type: none"> Check the motor wiring. Check the motor contactor and the contactor sequence. Make sure does not open during operation.
Brake Response Error SE4 (SE4)		○	The brake close command was set but the status of the brake feedback signal did not change.	<ul style="list-style-type: none"> Make sure the brake works properly. Check the brake feedback input.

Digital Operator	AL	FLT	Possible Cause	Corrective Action
Motor Pull Out or Step Out Detection 5f0 (STo)		○	<ul style="list-style-type: none"> The wrong motor code has been set (Yaskawa motors only). Load is too heavy. Accel/decel ramp is too short. 	<ul style="list-style-type: none"> Enter the correct motor code for the PM being used into the E5 parameters. For special-purpose motors, enter the correct data to all E5 parameters according to the Test Report provided for the motor. Reduce the load. Increase the motor or drive capacity. Increase the acceleration and deceleration times (C1-01 through C1-08). Increase the jerk setting in C2-02 through C2-05 (decrease if o1-03 > 3).
Position Lock Error 5uE (SvE)		○	The motor turned too much out of the target position during position lock operation.	<ul style="list-style-type: none"> Check the speed control loop parameters (C5-□□) and adjust if necessary. Check the position lock settings (S3-01/S3-02/S3-03). Check the speed feedback signal for noise.
DC Bus Undervoltage Uu1 (Uv1)	○	○	<ul style="list-style-type: none"> The voltage in the DC bus fell below the undervoltage detection level (L2-05). The power supply failed or one input phase has been lost. The power supply is too weak. 	<ul style="list-style-type: none"> Check the power supply. Make sure that the power supply can provide enough voltage.
Control Power Supply Undervoltage Uu2 (Uv2)		○	The control power supply does not have enough voltage.	<ul style="list-style-type: none"> Cycle power to the drive. Check if the fault reoccurs. Replace the drive if the fault continues to occur.
Soft Charge Circuit Fault Uu3 (Uv3)		○	The charge circuit for the DC bus is broken.	<ul style="list-style-type: none"> Cycle power to the drive and see if the fault reoccurs. Replace the drive if the fault reoccurs.

◆ Operator Programming Errors

An Operator Programming Error (oPE) occurs when an inapplicable parameter is set or an individual parameter setting is inappropriate. When an oPE error is displayed, press the ENTER button to display U1-18. Monitor U1-18 will display the parameter that is causing the oPE error.

Digital Operator	Possible Cause	Corrective Action
oPE01 (oPE01)	Drive capacity and the value set to o2-04 do not match.	Set to o2-04 to the correct value.
oPE02 (oPE02)	Parameters were set outside the allowable setting range.	Set parameters to the proper values.
oPE03 (oPE03)	<p>A contradictory setting is assigned to multi-function contact inputs H1-03 through to H1-08.</p> <ul style="list-style-type: none"> The same function is assigned to two multi-function inputs. Excludes “Brake feedback” and “Brake feedback 2.” Brake Feedback (H1-□□ = 79) or Brake Feedback 2 (H1-□□ = 5B) function is assigned to three or more multi-function inputs. Motor contactor feedback and Motor contactor feedback 2 (56 vs. 5A) are selected simultaneously. 	<ul style="list-style-type: none"> Fix any incorrect settings. Refer to the Technical Manual for more details.
oPE05 (oPE05)	The source of the Up/Down command or speed reference is assigned to option card (b1-01 or b1-02 = 3), but no option card is installed.	<ul style="list-style-type: none"> Install the required option card. Correct the values set to b1-01 and b1-02.
oPE06 (oPE06)	A control mode has been selected that requires an encoder to be installed, but no encoder is installed (A1-02 = 3 or 7).	<ul style="list-style-type: none"> Connect an encoder. Correct the value set to A1-02.
oPE07 (oPE07)	H3-02 and H3-10 are set to the same value (this excludes settings 0 and F).	<ul style="list-style-type: none"> Fix any incorrect settings. Refer to the Technical Manual for more details.
oPE08 (oPE08)	A function has been set that cannot be used in the control mode selected (this error often appears after the control mode has been changed).	<ul style="list-style-type: none"> Fix any incorrect setting. Refer to the Technical Manual for more details.
oPE10 (oPE10)	The V/f pattern setting is incorrect.	<ul style="list-style-type: none"> Check the V/f pattern settings. Refer to the Technical Manual for more details.
oPE21 (oPE21)	Elevator parameter settings are incorrect.	<ul style="list-style-type: none"> Check the elevator parameter settings. Refer to the Technical Manual for more details.

◆ Auto-Tuning Errors

Digital Operator	Cause	Corrective Action
E_r-01 (Er-01)	Motor Data Error The input motor data are not valid. (e.g. the base frequency and base speed do not fit).	Re-enter the data and repeat Auto-Tuning.
E_r-02 (Er-02)	Alarm <ul style="list-style-type: none"> The wiring is faulty. Drive was in baseblock condition or the Safe Disable Input were open during Auto-Tuning. 	Check the wiring.
E_r-03 (Er-03)	STOP Key Pressed The STOP key was pressed and Auto-Tuning was canceled.	Repeat the Auto-Tuning.
E_r-04 (Er-04)	Line-to-Line Resistance Fault <ul style="list-style-type: none"> Wrong input data. Auto tuning exceeded the given time frame. Calculated values out of range. 	<ul style="list-style-type: none"> Check the input data. Check the wiring. Re-enter the data and repeat the Auto-Tuning.
E_r-05 (Er-05)	No-Load Current Error <ul style="list-style-type: none"> Wrong input data. Auto tuning exceeded the given time frame. Calculated values out of range. 	
E_r-08 (Er-08)	Rated Slip Error <ul style="list-style-type: none"> Wrong input data. Auto tuning exceeded the given time frame. Calculated values out of range. 	
E_r-09 (Er-09)	Acceleration Error The motor did not accelerate following the specified acceleration ramp.	<ul style="list-style-type: none"> Lengthen the acceleration ramp. Increase C1-01 if set in s, decrease C1-01 if set in m/s². Check the torque limits L7-01 and L7-02.
E_r-11 (Er-11)	Motor Speed Error The torque reference was too high.	<ul style="list-style-type: none"> Lengthen the acceleration ramp. Increase C1-01 if set in s, decrease C1-01 if set in m/s². If possible, disconnect the load.
E_r-12 (Er-12)	Current Detection Error <ul style="list-style-type: none"> One or all output phases are lost. Current is either too low or exceeds the drives rating. The current sensors are faulty. 	<ul style="list-style-type: none"> Check the wiring. Make sure the motor contactor is closed during tuning. Make sure, that the drive rating fits to the motor. Check the load. (Auto-Tuning should have been performed without the load connected or with very low load.) Replace the drive.
E_r-13 (Er-13)	Leakage Inductance Error Drive was unable to complete tuning for leakage inductance within 300 s.	<ul style="list-style-type: none"> Check all wiring and correct any mistakes. Double check the motor rated current value that was entered to T1-04 for Auto-Tuning. Check the motor rated current value written on the motor nameplate and enter the correct value.
E_r-18 (Er-18)	Induction Voltage Error The induced voltage constant attempted to set a value outside the allowable setting range.	Double check the data that was entered to the T2-□□ parameters, and perform Auto-Tuning again.
E_r-19 (Er-19)	Inductance Error The induced voltage constant attempted to set a value to E5-09 outside the allowable range.	
E_r-20 (Er-20)	Stator Resistance Error Stator resistance tuning attempted to set a value to E5-06 that is outside the allowable setting range.	
E_r-21 (Er-21)	Encoder Offset Compensation Error Motor is coasting when Auto-Tuning is initiated.	Make sure the motor has stopped completely. Repeat Auto-Tuning.
	Either the motor or the encoder on the motor is not properly wired.	Check the wiring for the motor and the encoder. Repeat Auto-Tuning.
	The direction for the encoder is set incorrectly, or the number of pulses set for the encoder is incorrect.	Check the direction setting by F1-05 and b1-14 and number of pulses (F1-01) set for the encoder. Repeat Auto-Tuning.
	Encoder is damaged.	Check the signal output from the encoder attached to the motor. Replace the encoder if damaged.
	PG-E3 option detected excess position error with the ERN1387 encoder.	If other possible solutions are not successful, perform Auto-Tuning of PG-E3 encoder characteristics.

Digital Operator	Cause	Corrective Action
E_{r-22} (Er-22)	Initial Rotor Pole Search Error Initial pole search tuning found that the encoder offset cannot be tuned without rotating the motor.	<ul style="list-style-type: none"> Perform rotating encoder offset tuning. If a PG-X3 option card with an incremental encoder is used, replace the encoder by an absolute encoder.
E_{r-23} (Er-23)	Non-rotating Encoder Offset Tuning Warning A too large error occurred when the drive attempted to detect the rotor position during non-rotating encoder offset tuning.	Perform rotating encoder offset tuning.
E_{nd1} (End1)	Excessive V/f Setting <ul style="list-style-type: none"> The torque reference exceeded 20% during Auto-Tuning. The calculated no-load current is above 80% of the motor rated current. 	<ul style="list-style-type: none"> Check the V/f pattern setting. Perform Auto-Tuning without the load connected. Check the input data and repeat Auto-Tuning.
E_{nd2} (End2)	Motor Iron-Core Saturation Coefficient <ul style="list-style-type: none"> Calculated core saturation values out of range. Incorrect data was entered. 	<ul style="list-style-type: none"> Check the input data. Check the motor wiring. Perform Auto-Tuning without load connected.
E_{nd3} (End3)	Rated Current Setting Alarm	Check the input data and repeat tuning.
E_{nd4} (End4)	Adjusted Slip Calculation Error The slip that was calculated is outside the allowable range.	<ul style="list-style-type: none"> Make sure the data entered for Auto-Tuning is correct. Execute Rotational Auto-Tuning instead. If not possible, try Stationary Auto-Tuning 2.
E_{nd5} (End5)	Resistance Tuning Error The resistance value that was calculated is outside the allowable range.	<ul style="list-style-type: none"> Double check the data that was entered for the Auto-Tuning process. Check the motor and motor cable connection for faults.
E_{nd6} (End6)	Leakage Inductance Alarm <ul style="list-style-type: none"> A1-02 setting error The leakage inductance value that was calculated is outside the allowable range. 	<ul style="list-style-type: none"> Check the setting of parameter A1-02. Check the control mode and repeat Auto-Tuning. Double check the data that was entered for the Auto-Tuning process.
E_{nd7} (End7)	No-Load Current Alarm <ul style="list-style-type: none"> The entered no-load current value was outside the allowable range. Auto-Tuning results were less than 5% of the motor rated current. 	<ul style="list-style-type: none"> Check and correct faulty motor wiring. Double check the data that was entered for the Auto-Tuning process.

9 Safe Disable Input Function

This section briefly explains the Safe Disable function and how to use it in an elevator installation. Refer to the Technical Manual or contact Yaskawa for more detailed information.

◆ Safety Standards

The TUV mark indicates compliance with safety standards.



Figure 3 TUV mark

■ Standard Models (CIMR-L□□A□)

Safety Standards	Applicable Harmonized Standards
Functional Safety	IEC/EN 61508 series (SIL2)
Safety of Machinery	IEC/EN 61800-5-2 (SIL2)
EMC	ISO/EN ISO 13849-1/AC: 2009 (PL d (Cat.3))
	EN 61800-3:2004/A1: 2012
	IEC 61800-3:2004/A1: 2011

■ Models in Compliance with IEC/EN 61508 SIL3 (CIMR-L□□F□)

Safety Standards	Applicable Harmonized Standards
Functional Safety	IEC/EN 61508 series: 2010 (SIL3)
Safety of Machinery	IEC/EN 62061: 2005 (SILCL3)
EMC	IEC/EN 61800-5-2: 2007 (SIL3)
	ISO/EN ISO 13849-1/AC: 2009 (PL e (Cat.3))
	IEC/EN 61326-3-1: 2008 (EMC-related)

The Safe Disable function is in compliance with these standards.

◆ Specifications

The Safe Disable circuit consists of two independent hardware input channels that can block the output transistors. It provides a stop function in compliance with “Safe Torque Off” as defined in the IEC/EN 61800-5-2. Safe Disable inputs have been designed to meet the requirements of the ISO/EN 13849-1 and IEC/EN 61508.

Inputs / Outputs		<ul style="list-style-type: none"> Inputs: 2 Safe Disable inputs H1, H2 Signal ON level: 18 to 28 Vdc Signal OFF level: -4 to 4 Vdc Output: 1 Safe Disable Monitor output EDM (DM+, DM-)
Response Time from Input Open to Drive Output Stop		CIMR-L□□A□: less than 1 ms CIMR-L□□F□: less than 3 ms
Response Time from Input Open of H1 and H2 Terminals to EDM		CIMR-L□□A□: less than 1 ms CIMR-L□□F□: less than 4 ms
Failure Probability	Demand Rate Low	CIMR-L□□A□: PFD = 5.15E ⁻⁵ CIMR-L□□F□: PFD = 8.14E ⁻⁶
	Demand Rate High or Continuous	CIMR-L□□A□: PFH = 1.2E ⁻⁹ CIMR-L□□F□: PFH = 1.96E ⁻⁹
Performance Level		The Safe Disable inputs satisfy the following requirements (DC from EDM considered). CIMR-L□□A□: Performance Level (PL) d according to ISO/EN 13849-1 CIMR-L□□F□: Performance Level (PL) e according to ISO/EN 13849-1
HFT (Hardware Fault Tolerance)		N = 1
Classification of Subsystem		Type B

◆ Precautions

DANGER! Sudden Movement Hazard. Improper use of the Safe Disable function can result in serious injury or even death. Make sure the entire system or machinery uses the Safe Disable function in compliance with safety requirements. When implementing the Safe Disable function into the safety system of a machine, a thorough risk assessment and validation for the whole system must be carried out to ensure it complies with relevant safety norms (e.g., ISO/EN 13849, IEC/EN 61508, IEC/EN 62061).

DANGER! Sudden Movement Hazard. When using a PM motor, even if the drive output is shut off by the Safe Disable function, a break down of two output transistors can cause current to flow through the motor winding, resulting in a rotor movement for a maximum angle of 180 degree (electrically). Ensure this condition will not affect the safety of the application when using the Safe Disable function. This is not a concern with induction motors.

DANGER! Electrical Shock Hazard. The Safe Disable function can switch off the drive output, but does not cut the drive power supply and cannot electrically isolate the drive output from the input. Always shut off the drive power supply when performing maintenance or installations on the drive input side as well as the drive output side.

WARNING! Sudden Movement Hazard. If the motor is subjected to an external force, use a mechanical brake that meets the safety requirements of entire system or machinery to stop the machine connected to the load. The motor will move when an external gravitational force in the vertical axis is applied even if the Safety Disable function is in operation. Failure to comply may result in serious injury or death.

WARNING! Sudden Movement Hazard. Connect the Safe Disable inputs to the devices in compliance with safety requirements. Failure to comply will result in death or serious injury.

WARNING! Sudden Movement Hazard. When using the Safe Disable inputs, make sure to remove the wire links between terminals H1, H2, and HC that were installed prior to shipment. Failing to do so will keep the Safe Disable circuit from operating properly and can cause injury or even death.

WARNING! All safety features (including Safe Disable) should be inspected periodically. If the system is not operating normally, there is a risk of serious personal injury.

WARNING! Only a qualified technician with a thorough understanding of the drive, the instruction manual, and safety standards should be permitted to wire, inspect, and maintain the Safe Disable input. Failure to comply may result in serious injury or death.

WARNING! Sudden Movement Hazard. The logic of terminals DM+/DM- is inverted between drive models CIMR-L□□A□ and CIMRL□□F□. Check all wiring to ensure that the sequence is correct after installing the drive and connecting any other devices. Improper wiring connections could result in death or serious injury.

NOTICE: From the moment terminal inputs H1 and H2 have opened, it takes up to 1 ms for the drive output of models CIMR-L□□A□ to shut off completely, or up to 3 ms for the drive output of models CIMR-L□□F□ to shut off completely. The sequence set up to trigger terminals H1 and H2 should confirm that both terminals remain open for at least 1 ms in order to properly interrupt the drive output of models CIMR-L□□A□, or for at least 3 ms in order to properly interrupt the drive output of models CIMR-L□□F□. This may result in the Safe Disable Input not activating.

NOTICE: The Safe Disable Monitor (output terminals DM+ and DM-) should not be used for any other purpose than to monitor the Safe Disable status or to discover a malfunction in the Safe Disable inputs. The monitor output is not considered a safe output.

NOTICE: When utilizing the Safe Disable function, use only the EMC filters recommended in [EMC Filter Installation on page 14](#).

NOTICE: Performance Level d can only be achieved if the EDM output is used like shown in the example below.

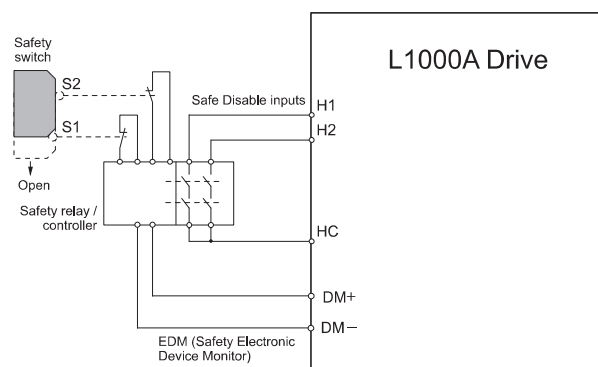

◆ Safe Disable Monitor Output Function and Digital Operator Display

The table below explains the drive output and Safe Disable monitor state depending on the Safe Disable inputs.

Drive Model	Safe Disable Input		Safe Disable Monitor EDM (DM+, DM-)	Safe Disable Monitor (H2-□□ = 58)	Drive Output	Digital Operator Display
	Input 1, H1-HC	Input 2, H2-HC				
CIMR-L□□A□	Off	Off	Off	On	Safely disabled, "Safe Torque Off"	Hbb (flashes)
	On	Off	On	On	Safely disabled, "Safe Torque Off"	HbbF (flashes)
	Off	On	On	On	Safely disabled, "Safe Torque Off"	HbbF (flashes)
	On	On	On	Off	Baseblock, ready for operation	Normal display
CIMR-L□□F□	Off	Off	On	On	Safely disabled, "Safe Torque Off"	Hbb (flashes)
	On	Off	Off	On	Safely disabled, "Safe Torque Off"	HbbF (flashes)
	Off	On	Off	On	Safely disabled, "Safe Torque Off"	HbbF (flashes)
	On	On	Off	Off	Baseblock, ready for operation	Normal display

If a fault in the safety circuit of the drive is detected, "SCF" will be displayed in the LCD operator. This indicates damage to the drive. Refer to [General Fault and Alarms on page 42](#) for details.

■ Validating Safe Disable Function

When you start-up, replace parts or conduct maintenance, you must always perform the following validation test on the safe disable inputs after completing the wiring. (Check results should be maintained as a record of tests performed.)

- When the H1 and H2 signals turn OFF, confirm that "Hbb" is displayed on the LCD operator, and that the motor is not in operation.
- Monitor the ON/OFF status of the H1 and H2 signals and confirm the EDM signal by referring to the table above.

If the ON/OFF status of the signals do not coincide with the display, the following must be considered: an error in the external device, disconnection of the external wiring, short circuit in the external wiring, or a failure in the drive. Find the cause and correct the problem.

- In normal operation, confirm the EDM signal by referring to the table above.

10 EN81-1/20 Conform Circuit with one Motor Contactor

◆ Installation

The safe disable circuit can be utilized to install the drive models CIMR-L□□□□ in an elevator system using only one motor contactor instead of two. In such a system the following guidelines must be followed to comply with EN81-1 or EN81-20:

- The circuit must be designed so that the inputs H1 and H2 are opened and the drive output shuts off when the safety chain is interrupted.
- A drive digital output must be programmed as Safe Disable Status (H2-□□ = 58). This feedback signal must be implemented in the contactor supervision circuit of the controller that prevents a restart in case of a fault in the Safe Disable circuit or the motor contactor.
- All contactors and wiring must be selected and installed in compliance with EN81-1 or EN81-20.
- The safe disable inputs H1 and H2 must be used to enable/disable the drive. The input logic must be set to Source Mode, i.e. jumper S3 must be set like shown below.

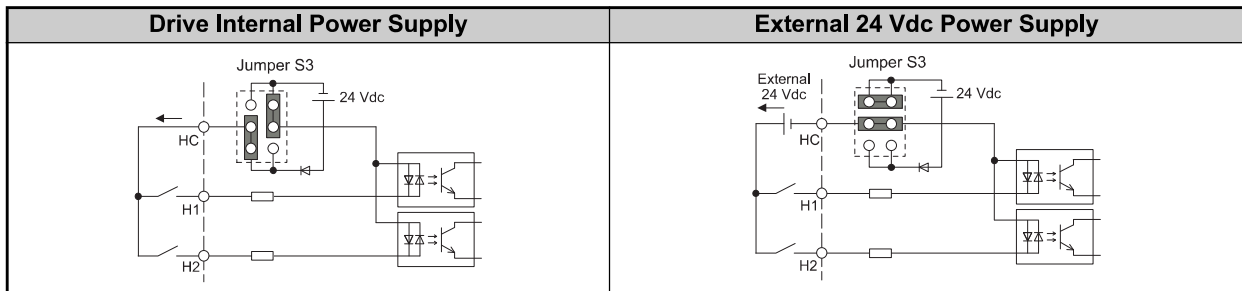

The figure below shows a wiring example.

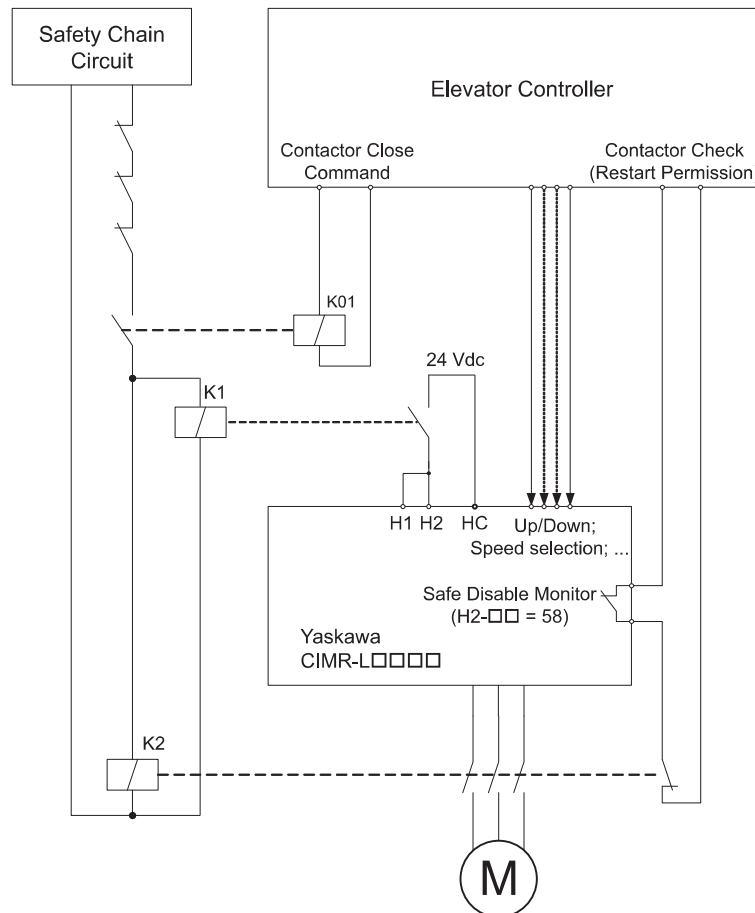

- Note:**
1. The drive output will immediately shut off when either of the inputs H1 or H2 is opened. In this case the brake should apply immediately in order to prevent uncontrolled movement of the elevator.
 2. Terminals H1 and H2 must be closed prior to setting the Up/Down command.

11 EN81-20 Conform Circuit with No Motor Contactor

◆ Installation

The safe disable circuit can be utilized to install the drive models CIMR-L□□ F□ in an elevator system with no motor contactor. In such a system, the following guidelines must be followed to comply with EN81-20:

- The circuit must be designed so that the inputs H1 or H2 are opened and the drive output shuts off when the safety chain is interrupted.
- The safe disable inputs H1 and H2 must be used to enable/disable the drive. The input logic must be set to Source Mode, i.e. jumper S3 must be set like shown below.

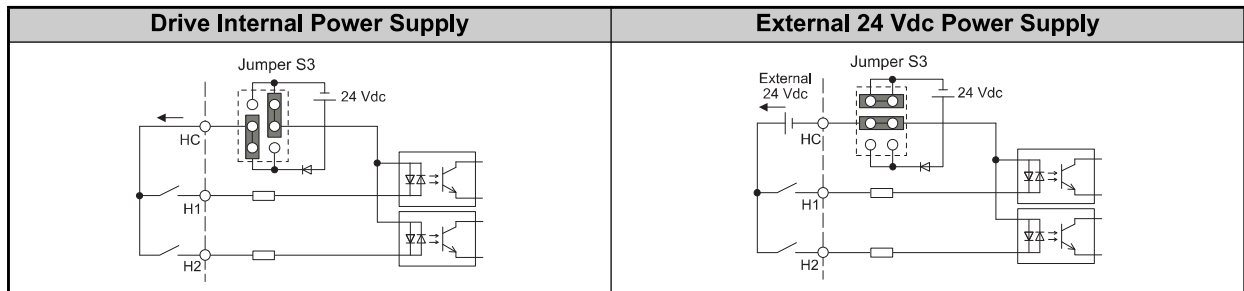

The figure below shows a wiring example.

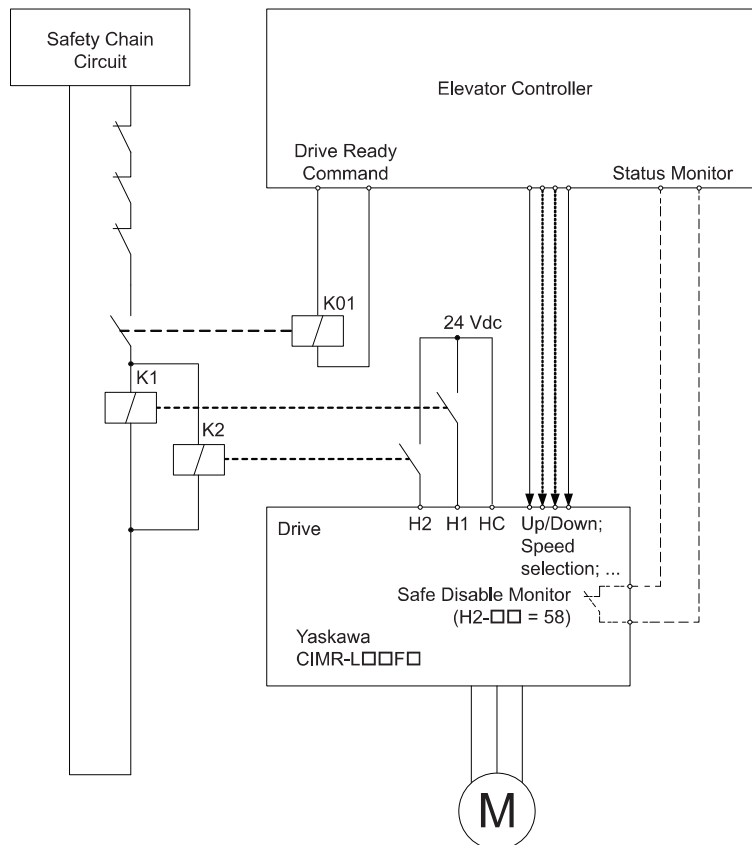

- Note:**
1. The drive output will immediately shut off when either of the inputs H1 or H2 is opened. In this case the brake should apply immediately in order to prevent uncontrolled movement of the elevator.
 2. Terminals H1 or H2 must be closed prior to setting the Up/Down command.
 3. A drive digital output must be programmed as Safe Disable feedback (H2-□□ = 58). This feedback signal can be implemented in the contactor supervision circuit of the controller that monitors a fault in the Safe Disable circuit.

12 UL Standards

◆ Precautions for UL/cUL Standards Compliance

The UL/cUL mark applies to products in the United States and Canada. It indicates that UL has performed product testing and evaluation, and determined that their stringent standards for product safety have been met. For a product to receive UL certification, all components inside that product must also receive UL certification.



This drive is tested in accordance with UL standard UL508C and complies with UL requirements. To ensure continued compliance when using this drive in combination with other equipment, meet the following conditions:

■ Installation Area

Do not install the drive to an area greater than pollution degree 2 (UL standard).

◆ Ambient Temperature

IP20 enclosure: -10 to +50°C

■ Main Circuit Terminal Wiring

Yaskawa recommends using closed-loop crimp terminals on all drive models. UL/cUL approval requires the use of UL Listed closed-loop crimp terminals when wiring the drive main circuit terminals on models CIMR-L□2□0085 to 2□0415 and 4□0045 to 4□0216. Use only the tools recommended by the terminal manufacturer for crimping.

The wire gauges listed in the tables below are Yaskawa recommendations. Refer to local codes for proper wire gauge selections.

Three-Phase 200 V Class

Model CIMR-L□	Terminal	For Europe and China <1>		For Asia <2>		For U.S.A <3>		Screw Size	Tightening Torque N·m (lb.in.)
		Recommended Gauge mm ²	Applicable Gauge mm ²	Recommended Gauge mm ²	Applicable Gauge mm ²	Recommended Gauge AWG, kcmil	Applicable Gauge AWG, kcmil		
2□0008 <4>	R/L1, S/L2, T/L3	2.5	2.5 to 6	2	2 to 5.5	14	14 to 10	M4	1.2 to 1.5 (10.6 to 13.3)
	U/T1, V/T2, W/T3	2.5	2.5 to 6	2	2 to 5.5	14	14 to 10		
	-, +1, +2	–	2.5 to 6	2	2 to 5.5	–	14 to 10		
	B1, B2	–	2.5 to 6	2	2 to 5.5	–	14 to 10		
	⊕	2.5	2.5 to 6	2	2 to 5.5	10	14 to 10		
2□0011 <4>	R/L1, S/L2, T/L3	2.5	2.5 to 6	2	2 to 5.5	12	14 to 10	M4	1.2 to 1.5 (10.6 to 13.3)
	U/T1, V/T2, W/T3	2.5	2.5 to 6	2	2 to 5.5	14	14 to 10		
	-, +1, +2	–	2.5 to 6	2	2 to 5.5	–	14 to 10		
	B1, B2	–	2.5 to 6	2	2 to 5.5	–	14 to 10		
	⊕	2.5	2.5 to 6	3.5	2 to 5.5	10	14 to 10		
2□0018 <4>	R/L1, S/L2, T/L3	4	2.5 to 6	5.5	3.5 to 5.5	10	12 to 10	M4	1.2 to 1.5 (10.6 to 13.3)
	U/T1, V/T2, W/T3	2.5	2.5 to 6	3.5	3.5 to 5.5	10	12 to 10		
	-, +1, +2	–	4 to 6	5.5	3.5 to 5.5	–	12 to 10		
	B1, B2	–	2.5 to 6	2	2 to 5.5	–	14 to 10		
	⊕	4	4 to 6	3.5	3.5 to 5.5	10	12 to 10		

12 UL Standards

Model CIMR-L□	Terminal	For Europe and China <1>		For Asia <2>		For U.S.A <3>		Screw Size	Tightening Torque N·m (lb.in.)
		Recommended Gauge mm ²	Applicable Gauge mm ²	Recommended Gauge mm ²	Applicable Gauge mm ²	Recommended Gauge AWG, kcmil	Applicable Gauge AWG, kcmil		
2□0025 <4>	R/L1, S/L2, T/L3	6	4 to 16	14	5.5 to 14	8	10 to 6	M4	2.1 to 2.3 (18.6 to 20.4)
	U/T1, V/T2, W/T3	6	4 to 16	8	5.5 to 14	8	10 to 6		
	-, +1, +2	-	6 to 16	14	5.5 to 14	-	10 to 6		
	B1, B2	-	4 to 6	3.5	2 to 5.5	-	14 to 10		
	⊕	6	6 to 10	5.5	5.5 to 8	8	10 to 8	M5	2.0 to 2.5 (17.7 to 22.1)
2□0033 <4>	R/L1, S/L2, T/L3	10	6 to 16	14	14	6	8 to 6	M4	2.1 to 2.3 (18.6 to 20.4)
	U/T1, V/T2, W/T3	10	6 to 16	14	8 to 14	8	8 to 6		
	-, +1, +2	-	16	14	14	-	6		
	B1, B2	-	4 to 6	5.5	3.5 to 5.5	-	12 to 10		
	⊕	10	6 to 10	5.5	5.5 to 8	8	10 to 8	M5	2.0 to 2.5 (17.7 to 22.1)
2□0047	R/L1, S/L2, T/L3	16	16 to 25	22	14 to 22	4	6 to 4	M6	5.4 to 6.0 (47.8 to 53.1)
	U/T1, V/T2, W/T3	16	16 to 25	14	14 to 22	4	6 to 4		
	-, +1, +2	-	16 to 25	22	14 to 22	-	6 to 4		
	B1, B2	-	6 to 10	14	5.5 to 14	-	10 to 6	M5	2.7 to 3.0 (23.9 to 26.6)
	⊕	16	10 to 16	8	8 to 14	6	8 to 6	M6	5.4 to 6.0 (47.8 to 53.1)
2□0060	R/L1, S/L2, T/L3	25	16 to 25	30	22 to 30	3	4 to 3	M8	9.9 to 11.0 (87.6 to 97.4)
	U/T1, V/T2, W/T3	16	16 to 25	22	14 to 30	3	4 to 3		
	-, +1, +2	-	25	30	22 to 30	-	4 to 3		
	B1, B2	-	10 to 16	14	8 to 14	-	8 to 6	M5	2.7 to 3.0 (23.9 to 26.6)
	⊕	16	16 to 25	8	8 to 22	6	6 to 4	M6	5.4 to 6.0 (47.8 to 53.1)
2□0075	R/L1, S/L2, T/L3	35	25 to 35	38	30 to 38	2	3 to 2	M8	9.9 to 11.0 (87.6 to 97.4)
	U/T1, V/T2, W/T3	25	25 to 35	30	22 to 38	2	3 to 2		
	-, +1, +2	-	25 to 35	38	30 to 38	-	3 to 2		
	B1, B2	-	16	14	14	-	6	M5	2.7 to 3.0 (23.9 to 26.6)
	⊕	16	16 to 25	14	14 to 22	6	6 to 4	M6	5.4 to 6.0 (47.8 to 53.1)
2□0085 <5>	R/L1, S/L2, T/L3	35	25 to 50	38	30 to 50	1/0	3 to 1/0	M8	9 to 11 (79.7 to 97.4)
	U/T1, V/T2, W/T3	35	25 to 50	38	30 to 50	1/0	3 to 1/0		
	-, +1	-	35 to 50	60	38 to 60	-	2 to 1/0		
	B1, B2	-	16 to 50	22	14 to 50	-	6 to 1/0		
	⊕	16	16 to 25	14	14 to 38	6	6 to 4		
2□0115 <5>	R/L1, S/L2, T/L3	50	35 to 70	60	50 to 60	2/0	1 to 2/0	M10	18 to 23 (159 to 204)
	U/T1, V/T2, W/T3	50	35 to 70	60	50 to 60	2/0	1 to 2/0		
	-, +1	-	50 to 70	80	60 to 80	-	1/0 to 3/0		
	B1, B2	-	25 to 70	30	22 to 60	-	4 to 2/0		
	⊕	25	25	22	22 to 38	4	4	M8	9 to 11 (79.7 to 97.4)

Model CIMR-L□	Terminal	For Europe and China <1>		For Asia <2>		For U.S.A <3>		Screw Size	Tightening Torque N·m (lb.in.)
		Recommended Gauge mm ²	Applicable Gauge mm ²	Recommended Gauge mm ²	Applicable Gauge mm ²	Recommended Gauge AWG, kcmil	Applicable Gauge AWG, kcmil		
2□0145 <5>	R/L1, S/L2, T/L3	70	50 to 95	80	60 to 100	4/0	2/0 to 4/0	M10	18 to 23 (159 to 204)
	U/T1, V/T2, W/T3	70	50 to 95	80	60 to 100	4/0	3/0 to 4/0		
	-, +1	–	35 to 95	50 × 2P	50 to 100	–	1 to 4/0		
	+3	–	50 to 95	60	50 to 100	–	1/0 to 4/0		
	⊕	35	25 to 35	22	22 to 60	4	4 to 2	M10	9 to 11 (79.7 to 97.4)
2□0180 <5>	R/L1, S/L2, T/L3	95	70 to 95	100	80 to 100	1/0 × 2P	1/0 to 2/0	M10	18 to 23 (159 to 204)
	U/T1, V/T2, W/T3	95	70 to 95	50 × 2P	50 to 60	1/0 × 2P	1/0 to 2/0		
	-, +1	–	35 to 95	50 × 2P	50 to 100	–	1 to 4/0		
	+3	–	50 to 95	80	60 to 100	–	1/0 to 4/0		
	⊕	50	25 to 50	22	22 to 60	4	4 to 1/0	M10	9 to 11 (79.7 to 97.4)
2□0215 <5>	R/L1, S/L2, T/L3	95 × 2P	95 to 150	80 × 2P	38 to 150	3/0 × 2P	3/0 to 300	M12	32 to 40 (283 to 354)
	U/T1, V/T2, W/T3	95 × 2P	95 to 150	80 × 2P	38 to 150	3/0 × 2P	3/0 to 300		
	-, +1	–	70 to 150	80 × 2P	80 to 150	–	3/0 to 300	M10	18 to 23 (159 to 204)
	+3	–	35 to 150	80 × 2P	30 to 150	–	2 to 300		
	⊕	95	95 to 150	22	22 to 150	3	3 to 300		
2□0283 <5>	R/L1, S/L2, T/L3	95 × 2P	95 to 150	80 × 2P	70 to 150	4/0 × 2P	3/0 to 300	M12	32 to 40 (283 to 354)
	U/T1, V/T2, W/T3	95 × 2P	95 to 150	80 × 2P	70 to 200	3/0 × 2P	3/0 to 300		
	-, +1	–	70 to 150	150 × 2P	80 to 150	–	3/0 to 300	M10	18 to 23 (159 to 204)
	+3	–	70 to 150	80 × 2P	80 to 150	–	3/0 to 300		
	⊕	95	95 to 150	38	38 to 150	2	2 to 300		
2□0346 <5>	R/L1, S/L2, T/L3	240	95 to 300	100 × 2P	80 to 325	250 × 2P	4/0 to 600	M12	32 to 40 (283 to 354)
	U/T1, V/T2, W/T3	240	95 to 300	100 × 2P	80 to 325	4/0 × 2P	4/0 to 600		
	-, +1	–	125 to 300	150 × 2P	125 to 325	–	250 to 600	M10	18 to 23 (159 to 204)
	+3	–	70 to 300	80 × 2P	80 to 325	–	3/0 to 600		
	⊕	120	120 to 240	38	38 to 200	1	1 to 350		
2□0415 <5>	R/L1, S/L2, T/L3	120 × 2P	95 to 300	125 × 2P	100 to 325	350 × 2P	250 to 600	M12	32 to 40 (283 to 354)
	U/T1, V/T2, W/T3	300	95 to 300	125 × 2P	125 to 325	300 × 2P	300 to 600		
	-, +1	–	150 to 300	200 × 2P	150 to 325	–	300 to 600	M10	18 to 23 (159 to 204)
	+3	–	70 to 300	100 × 2P	80 to 325	–	3/0 to 600		
	⊕	120	120 to 240	60	60 to 200	1	1 to 350		

<1> Gauges listed here are for use in Europe and China.

<2> Gauges listed here are for use in Asia except for China.

<3> Gauges listed here are for use in the United States.

12 UL Standards

<4> When an EMC filter is installed, additional measures must be taken in order to comply with IEC/EN 61800-5-1.

<5> Drive models CIMR-L□2□0085 to 4□0415 require the use of closed-loop crimp terminals for UL/cUL compliance. Use only the tools recommended by the terminal manufacturer for crimping.

Note: Use crimp insulated terminals or insulated tubing for wiring these connections. Wires should have a continuous maximum allowable temperature of 75°C 600 V UL approved vinyl sheathed insulation. Ambient temperature should not exceed 40°C.

Three-Phase 400 V Class

Model CIMR-L□	Terminal	For Europe and China <1>		For Asia <2>		For U.S.A <3>		Screw Size	Tightening Torque N·m (lb.in.)
		Recommended Gauge mm ²	Applicable Gauge mm ²	Recommended Gauge mm ²	Applicable Gauge mm ²	Recommended Gauge AWG, kcmil	Applicable Gauge AWG, kcmil		
4□0005 4□0006	R/L1, S/L2, T/L3	2.5	2.5 to 6	2	2 to 5.5	14	14 to 10	M4	1.2 to 1.5 (10.6 to 13.3)
	U/T1, V/T2, W/T3	2.5	2.5 to 6	2	2 to 5.5	14	14 to 10		
	-, +1, +2	–	2.5 to 6	2	2 to 5.5	–	14 to 10		
	B1, B2	–	2.5 to 6	2	2 to 5.5	–	14 to 10		
	⊕	2.5	2.5 to 6	3.5	2 to 5.5	10	14 to 10		
4□0009	R/L1, S/L2, T/L3	2.5	2.5 to 6	2	2 to 5.5	12	14 to 10	M4	1.2 to 1.5 (10.6 to 13.3)
	U/T1, V/T2, W/T3	2.5	2.5 to 6	2	2 to 5.5	14	14 to 10		
	-, +1, +2	–	2.5 to 6	2	2 to 5.5	–	14 to 10		
	B1, B2	–	2.5 to 6	2	2 to 5.5	–	14 to 10		
	⊕	2.5	2.5 to 6	3.5	2 to 5.5	10	14 to 10		
4□0015	R/L1, S/L2, T/L3	2.5	2.5 to 16	3.5	2 to 14	10	12 to 6	M4	2.1 to 2.3 (18.6 to 20.4)
	U/T1, V/T2, W/T3	2.5	2.5 to 16	3.5	2 to 14	10	12 to 6		
	-, +1, +2	–	4 to 16	3.5	2 to 14	–	12 to 6		
	B1, B2	–	4 to 6	2	2 to 5.5	–	12 to 10		
	⊕	2.5	2.5 to 6	3.5	2 to 5.5	10	14 to 10	M5	2.0 to 2.5 (17.7 to 22.1)
4□0018	R/L1, S/L2, T/L3	4	2.5 to 16	5.5	3.5 to 14	10	10 to 6	M4	2.1 to 2.3 (18.6 to 20.4)
	U/T1, V/T2, W/T3	4	2.5 to 16	5.5	3.5 to 14	10	10 to 6		
	-, +1, +2	–	4 to 16	5.5	3.5 to 14	–	12 to 6		
	B1, B2	–	4 to 6	2	2 to 5.5	–	12 to 10		
	⊕	4	4 to 6	3.5	3.5 to 5.5	10	12 to 10	M5	2.0 to 2.5 (17.7 to 22.1)
4□0024	R/L1, S/L2, T/L3	6	6 to 16	14	5.5 to 14	8	8 to 6	M5	3.6 to 4.0 (31.8 to 35.4)
	U/T1, V/T2, W/T3	6	6 to 16	8	5.5 to 8	8	10 to 6		
	-, +1, +2	–	6 to 16	14	5.5 to 14	–	10 to 6		
	B1, B2	–	6 to 10	3.5	2 to 8	–	10 to 8	M5	2.7 to 3.0 (23.9 to 26.6)
	⊕	6	6 to 10	5.5	5.5 to 8	8	10 to 8	M6	5.4 to 6.0 (47.8 to 53.1)
4□0031	R/L1, S/L2, T/L3	10	10 to 16	14	14	6	8 to 6	M5	3.6 to 4.0 (31.8 to 35.4)
	U/T1, V/T2, W/T3	6	6 to 16	14	8 to 14	8	8 to 6		
	-, +1, +2	–	6 to 16	14	14	–	6		
	B1, B2	–	6 to 10	5.5	3.5 to 8	–	10 to 8	M5	2.7 to 3.0 (23.9 to 26.6)
	⊕	10	6 to 16	8	5.5 to 14	6	10 to 6	M6	5.4 to 6.0 (47.8 to 53.1)

Model CIMR-L□	Terminal	For Europe and China <1>		For Asia <2>		For U.S.A <3>		Screw Size	Tightening Torque N·m (lb.in.)
		Recommended Gauge mm ²	Applicable Gauge mm ²	Recommended Gauge mm ²	Applicable Gauge mm ²	Recommended Gauge AWG, kcmil	Applicable Gauge AWG, kcmil		
4□0039	R/L1, S/L2, T/L3	16	16 to 25	14	14 to 22	6	6 to 4	M6	5.4 to 6.0 (47.8 to 53.1)
	U/T1, V/T2, W/T3	16	16 to 25	14	14 to 22	6	6 to 4		
	-, +1, +2	–	16 to 25	14	14 to 22	–	6 to 4		
	B1, B2	–	6 to 10	8	5.5 to 8	–	10 to 8	M5	2.7 to 3.0 (23.9 to 26.6)
	⊕	16	10 to 16	8	8 to 14	6	8 to 6	M6	5.4 to 6.0 (47.8 to 53.1)
4□0045 ↔	R/L1, S/L2, T/L3	16	10 to 16	14	14	4	6 to 4	M8	9 to 11 (79.7 to 97.4)
	U/T1, V/T2, W/T3	16	10 to 16	14	14	4	6 to 4		
	-, +1	–	16 to 35	22	14 to 38	–	6 to 1		
	B1, B2	–	10 to 16	14	8 to 14	–	8 to 4		
	⊕	16	10 to 16	8	8 to 14	6	8 to 6		
4□0060 ↔	R/L1, S/L2, T/L3	16	16 to 25	22	14 to 22	3	4 to 3	M8	9 to 11 (79.7 to 97.4)
	U/T1, V/T2, W/T3	25	16 to 25	22	14 to 22	3	4 to 3		
	-, +1	–	25 to 35	30	22 to 38	–	4 to 1		
	B1, B2	–	16 to 25	14	14 to 22	–	6 to 3		
	⊕	16	16 to 25	14	14 to 22	6	6		
4□0075 ↔	R/L1, S/L2, T/L3	25	16 to 50	30	22 to 60	2	3 to 1/0	M8	9 to 11 (79.7 to 97.4)
	U/T1, V/T2, W/T3	25	25 to 50	30	22 to 60	2	3 to 1/0		
	-, +1	–	25 to 50	38	30 to 60	–	3 to 1/0		
	+3	–	16 to 50	22	14 to 60	–	6 to 1/0		
	⊕	16	16 to 25	22	14 to 22	4	6 to 4		
4□0091 ↔	R/L1, S/L2, T/L3	35	25 to 50	38	30 to 60	1/0	2 to 1/0	M8	9 to 11 (79.7 to 97.4)
	U/T1, V/T2, W/T3	35	25 to 50	38	30 to 60	1	2 to 1/0		
	-, +1	–	25 to 50	60	30 to 60	–	3 to 1/0		
	+3	–	25 to 50	30	22 to 60	–	4 to 1/0		
	⊕	16	16 to 25	22	14 to 22	4	6 to 4		
4□0112 ↔	R/L1, S/L2, T/L3	50	35 to 95	60	38 to 100	3/0	1/0 to 4/0	M10	18 to 23 (159 to 204)
	U/T1, V/T2, W/T3	50	35 to 95	60	60 to 100	2/0	1/0 to 4/0		
	-, +1	–	50 to 95	100	60 to 100	–	1/0 to 4/0		
	+3	–	25 to 95	50	30 to 100	–	3 to 4/0		
	⊕	25	25	22	22	4	4		
4□0150 ↔	R/L1, S/L2, T/L3	70	50 to 95	80	60 to 100	4/0	3/0 to 4/0	M10	18 to 23 (159 to 204)
	U/T1, V/T2, W/T3	70	70 to 95	80	80 to 100	4/0	3/0 to 4/0		
	-, +1	–	35 to 95	50 × 2P	50 to 100	–	1 to 4/0		
	+3	–	50 to 95	60	50 to 100	–	1/0 to 4/0		
	⊕	35	25 to 35	22	22 to 30	4	4 to 2		

12 UL Standards

Model CIMR-L□	Terminal	For Europe and China <1>		For Asia <2>		For U.S.A <3>		Screw Size	Tightening Torque N·m (lb.in.)
		Recommended Gauge mm ²	Applicable Gauge mm ²	Recommended Gauge mm ²	Applicable Gauge mm ²	Recommended Gauge AWG, kcmil	Applicable Gauge AWG, kcmil		
4□0180 <4>	R/L1, S/L2, T/L3	95	35 to 95	150	30 to 150	300	2 to 300	M10	18 to 23 (159 to 204)
	U/T1, V/T2, W/T3	95	35 to 95	150	30 to 150	300	2 to 300		
	-, +1	–	35 to 150	80 × 2P	38 to 150	–	1 to 250		
	+3	–	25 to 70	80	22 to 80	–	3 to 3/0		
	⊕	50	50 to 150	22	22 to 150	4	4 to 300		
4□0216 <4>	R/L1, S/L2, T/L3	120	95 to 300	150	38 to 325	400	1 to 600	M10	18 to 23 (159 to 204)
	U/T1, V/T2, W/T3	120	95 to 300	150	38 to 325	400	1/0 to 600		
	-, +1	–	70 to 300	200	80 to 325	–	3/0 to 600		
	+3	–	35 to 300	125	38 to 325	–	1 to 325		
	⊕	70	70 to 240	22	22 to 200	2	2 to 350		

<1> Gauges listed here are for use in Europe and China.

<2> Gauges listed here are for use in Asia except for China.

<3> Gauges listed here are for use in the United States.

<4> Drive models CIMR-L□4□0045 to 4□0216 require the use of closed-loop crimp terminals for UL/cUL compliance. Use only the tools recommended by the terminal manufacturer for crimping.

Note: Use crimp insulated terminals or insulated tubing for wiring these connections. Wires should have a continuous maximum allowable temperature of 75°C 600 V UL approved vinyl sheathed insulation. Ambient temperature should not exceed 40°C.

■ Closed-Loop Crimp Terminal Recommendations

Yaskawa recommends using closed-loop crimp terminals on all drive models. UL approval requires the use of crimp terminals when wiring the drive main circuit terminals on models CIMR-L□2□0085 to 2□0415 and 4□0045 to 4□0216. Use only crimping tools as specified by the crimp terminal manufacturer. Yaskawa recommends crimp terminals made by JST and Tokyo DIP (or equivalent) for the insulation cap.

The table below matches the wire gauges and terminal screw sizes with Yaskawa - recommended crimp terminals, tools, and insulation caps. Refer to the appropriate Wire Gauge and Torque Specifications table for the wire gauge and screw size for your drive model. Place orders with a Yaskawa representatives the Yaskawa sales department.

Wire Gauge	Terminal Screws	Crimp Terminal Model Number	Tool		Insulation Cap Model No.	Code <1>
			Machine No.	Die Jaw		
14 AWG	M4	R2-4	YA-4	AD-900	TP-003	100-054-028
12 / 10 AWG	M4	R5.5-4	YA-4	AD-900	TP-005	100-054-029
	M5	R5.5-5	YA-4	AD-900	TP-005	100-054-030
8 AWG	M4	8-4	YA-4	AD-901	TP-008	100-054-031
	M5	R8-5	YA-4	AD-901	TP-008	100-054-032
6 AWG	M4	14-NK4	YA-4	AD-902	TP-014	100-054-033
	M5	R14-5	YA-4	AD-902	TP-014	100-054-034
	M6	R14-6	YA-5	AD-952	TP-014	100-051-261
	M8	R14-8	YA-5	AD-952	TP-014	100-054-035
4 AWG	M6	R22-6	YA-5	AD-953	TP-022	100-051-262
	M8	R22-8	YA-5	AD-953	TP-022	100-051-263
3/2/1 AWG	M8	R38-8	YA-5	AD-954	TP-038	100-051-264
	M10	R38-10	YA-5	AD-954	TP-038	100-061-114
1/0 AWG	M8	R60-8	YA-5	AD-955	TP-060	100-051-265
1/0 AWG × 2P	M10	R60-10	YF-1, YET-300-1	TD-321, TD-311	TP-060	100-051-266
2/0 AWG 2/0 AWG × 2P	M10	70-10	YF-1, YET-300-1	TD-323, TD-312	TP-080	100-054-036
1 AWG × 2P 2 AWG × 2P	M10	38-L10	YF-1, YET-150-1	TD-224, TD-212	TP-038	100-051-556
3/0 AWG	M10	80-10	YF-1, YET-300-1	TD-323, TD-312	TP-080	100-051-267
3/0 AWG × 2P	M10	80-L10	YF-1, YET-150-1	TD-227, TD-214	TP-080	100-051-557
	M12	80-L12	YF-1, YET-300-1	TD-323, TD-312	TP-080	100-051-558
4/0 AWG	M10	R100-10	YF-1, YET-300-1 YF-1, YET-150-1	TD-324, TD-312 TD-228, TD-214	TP-100	100-051-269
4/0 AWG × 2P	M10	100-L10	YF-1, YET-150-1	TD-228, TD-214	TP-100	100-051-559
	M12	100-L12	YF-1, YET-300-1	TD-324, TD-312	TP-100	100-051-560
250 / 300 kcmil	M10	R150-10	YF-1, YET-150-1	TD-229, TD-215	TP-150	100-051-272
	M12	R150-12	YF-1, YET-300-1	TD-325, TD-313	TP-150	100-051-273
250 kcmil × 2P	M10	150-L10	YF-1, YET-150-1	TD-229, TD-215	TP-150	100-051-561
300 kcmil × 2P	M12	150-L12	YF-1, YET-300-1	TD-325, TD-313	TP-150	100-051-562
350 kcmil	M10	180-10	YF-1, YET-300-1	TD-326, TD-313	TP-200	100-066-687
400 kcmil	M10	200-10	YF-1, YET-300-1	TD-327, TD-314	TP-200	100-051-563
350 kcmil × 2P	M12	180-L12	YF-1, YET-300-1	TD-326, TD-313	TP-200	100-066-688
400 kcmil × 2P	M12	200-L12	YF-1, YET-300-1	TD-327, TD-314	TP-200	100-051-564
500 kcmil	M10	325-10	YF-1, YET-300-1	TD-328, TD-315	TP-325	100-051-565
600 / 650 kcmil 500 kcmil × 2P 600 kcmil × 2P	M12	325-12	YF-1, YET-300-1	TD-328, TD-315	TP-325	100-051-277

<1> Codes refer to a set of three crimp terminals and three insulation caps. Prepare input and output wiring using two sets for each connection.

Example 1: Models with 300 kcmil for both input and output require one set for input terminals and one set for output terminals, so the user should order two sets of [100-051-272].

Example 2: Models with 4/0 AWG × 2P for both input and output require two sets for input terminals and two sets for output terminals, so the user should order four sets of [100-051-560].

Note: Use crimp insulated terminals or insulated shrink tubing for wiring connections. Wires should have a continuous maximum allowable temperature of 75°C 600 Vac UL-approved vinyl-sheathed insulation.

◆ Installing Input Fuses

NOTICE: If a fuse is blown or a Residual Current Device (RCD) is tripped, check the wiring and the selection of the peripheral devices to identify the cause. Contact Yaskawa before restarting the drive or the peripheral devices if the cause cannot be identified.

■ Factory Recommended Branch Circuit Protection

Yaskawa recommends installing one of the following types of branch circuit protection to maintain compliance with UL508C. Semiconductor protective type fuses are preferred. Alternate branch circuit protection devices are also listed below.

Drive Model CIMR-L□	L1000A in Heavy Duty Mode (C6-01 = 0)				
	AC Drive Input Amps	MCCB Rating Amps <1>	Time Delay Fuse Rating Amps <2>	Non-time Delay Fuse Rating Amps <3>	Bussmann Semiconductor Fuse Rating (Fuse Ampere) <4>
Three-Phase 200 V Class					
2□0008	7.5	15	12	20	FWH-70B (70)
2□0011	11	20	17.5	30	FWH-70B (70)
2□0018	18.9	35	30	50	FWH-90B (90)
2□0025	28	50	40	75	FWH-100B (100)
2□0033	37	60	60	100	FWH-200B (200)
2□0047	52	100	90	150	FWH-200B (200)
2□0060	68	125	110	200	FWH-200B (200)
2□0075	80	150	125	225	FWH-300A (300)
2□0085	82	150	125	225	FWH-300A (300)
2□0115	111	200	175	250	FWH-350A (350)
2□0145	136	250	225	350	FWH-400A (400)
2□0180	164	300	250	450	FWH-400A (400)
2□0215	200	400	350	600	FWH-600A (600)
2□0283	271	500	450	800	FWH-700A (700)
2□0346	324	600	500	900 <5>	FWH-800A (800)
2□0415	394	700	600	1100 <5>	FWH-1000A (1000)
Three-Phase 400 V Class					
4□0005	4.4	15	7	12	FWH-70B (70)
4□0006	6	15	10	17.5	FWH-70B (70)
4□0009	10.4	20	17.5	30	FWH-90B (90)
4□0015	15	30	25	40	FWH-80B (80)
4□0018	20	40	35	60	FWH-100B (100)
4□0024	29	50	50	80	FWH-125B (125)
4□0031	39	75	60	110	FWH-200B (200)
4□0039	47	75	75	125	FWH-250A (250)
4□0045	43	75	75	125	FWH-250A (250)
4□0060	58	100	100	150	FWH-250A (250)
4□0075	71	125	110	200	FWH-250A (250)
4□0091	86	150	150	250	FWH-250A (250)
4□0112	105	175	175	300	FWH-350A (350)
4□0150	142	225	225	400	FWH-400A (400)
4□0180	170	250	250	500	FWH-500A (500)
4□0216	207	350	350	600	FWH-600A (600)

<1> Maximum MCCB Rating is 15 A, or 200% of drive input current rating, whichever is larger. MCCB voltage rating must be 600 Vac or greater.

<2> Maximum Time Delay fuse is 175% of drive input current rating. This covers any Class CC, J or T class fuse.

<3> Maximum Non-time Delay fuse is 300% of drive input current rating. This covers any CC, J or T class fuse.

<4> When using semiconductor fuses, Bussmann FWH and FWP are required for UL compliance. Select FWH for 200 V Class and 400 V Class models and FWP fuses for 600 V models.

<5> Class L fuse is also approved for this rating.

■ Low Voltage Wiring for Control Circuit Terminals

Wire low voltage wires with NEC Class 1 circuit conductors. Refer to national state or local codes for wiring. If external power supply used, it shall be UL Listed Class 2 power source only or equivalent. Refer to NEC Article 725 Class 1, Class 2, and Class 3 Remote-Control, Signaling, and Power Limited Circuits for requirements concerning class 1 circuit conductors and class 2 power supplies.

Input / Output	Terminal Signal	Power Supply Specifications
Open Collector Outputs	P1, C1, P2, C2, DM+, DM-	Requires class 2 power supply.
Digital inputs	S1-S8, SN, SC, SP, HC, H1, H2	Use the internal LVLC power supply of the drive. Use class 2 for external power supply.
Analog inputs / outputs	+V, -V, A1, A2, AC, AM, FM	Use the internal LVLC power supply of the drive. Use class 2 for external power supply.

■ Drive Short-Circuit Rating

This drive is suitable for use on a circuit capable of delivering not more than 100,000 RMS symmetrical amperes, 600 Vac maximum (Up to 240 V in 200 V class drives, up to 480 V for 400 V class drives) when protected by Bussmann Type FWH fuses as specified in *Installing Input Fuses on page 60*.

◆ Drive Motor Overload Protection

Set parameter E2-01/E5-03 (motor rated current) to the appropriate value to enable motor overload protection. The internal motor overload protection is UL listed and in accordance with the NEC and CEC.

■ E2-01/E5-03: Motor Rated Current (IM Motor/PM Motor)

Setting Range: Model Dependent

Default Setting: Model Dependent

Parameter E2-01/E5-03 (motor rated current) protects the motor if parameter L1-01 is not set to 0 (default is 1, enabling protection for standard induction motors).

If Auto-Tuning has been performed successfully, the motor data entered to T1-04/T2-04 is automatically written into parameter E2-01/E5-03. If Auto-Tuning has not been performed, manually enter the correct motor rated current to parameter E2-01/E5-03.

■ L1-01: Motor Overload Protection Selection

The drive has an electronic overload protection function (oL1) based on time, output current, and output speed, which protects the motor from overheating. The electronic thermal overload function is UL-recognized, so it does not require an external thermal relay for single motor operation.

This parameter selects the motor overload curve used according to the type of motor applied.

Setting	Description	
0	Disabled	Disabled the internal motor overload protection of the drive.
1	Standard fan-cooled motor (default)	Selects protection characteristics for a standard self cooled motor with limited cooling capabilities when running below the rated speed. The motor overload detection level (oL1) is automatically reduced when running below the motor rated speed.
2	Drive duty motor with a speed range of 1:10	Selects protection characteristics for a motor with self-cooling capability within a speed range of 10:1. The motor overload detection level (oL1) is automatically reduced when running below 1/10 of the motor rated speed.
3	Vector motor with a speed range of 1:100	Selects protection characteristics for a motor capable of cooling itself at any speed — including zero speed (externally cooled motor). The motor overload detection level (oL1) is constant over the entire speed range.
5	Permanent Magnet motor with constant torque	Selects protection characteristics for a constant torque PM motor. The motor overload detection level (oL1) is constant over the whole speed range.

When connecting the drive to more than one motor for simultaneous operation, disable the electronic overload protection (L1-01 = 0) and wire each motor with its own motor thermal overload relay.

Enable the motor overload protection (L1-01 = 1 to 3, 5) when connecting the drive to a single motor, unless another motor overload preventing device is installed. The drive electronic thermal overload function causes an oL1 fault, which shuts off the output of the drive and prevents additional overheating of the motor. The motor temperature is continually calculated while the drive is powered up.

■ L1-02: Motor Overload Protection Time

Setting Range: 0.1 to 5.0 min

Factory Default: 1.0 min

Parameter L1-02 determines how long the motor is allowed to operate before the oL1 fault occurs when the drive is running at 60 Hz and at 150% of the full load amp rating (E2-01/E5-03) of the motor. Adjusting the value of L1-02 can shift the set of oL1 curves up the y axis of the diagram below, but will not change the shape of the curves.

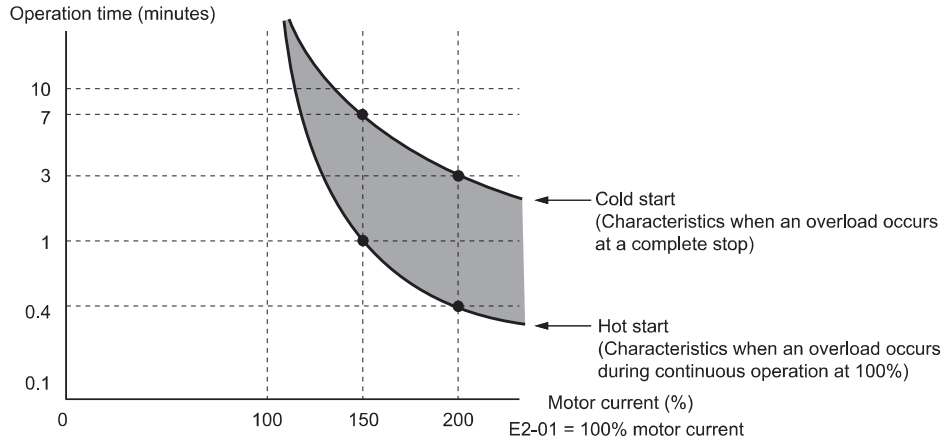

■ L1-03 Motor Overload Alarm Operation Selection

Setting	Description
0	Ramp to Stop
1	Coast to Stop
2	Fast-Stop
3	Alarm Only (default setting)

■ L1-04 Motor Overload Fault Operation Selection

Setting	Description
0	Ramp to Stop
1	Coast to Stop (default setting)
2	Fast-Stop

Revision History

The revision dates and the numbers of the revised manuals appear on the bottom of the back cover.

MANUAL NO. TOEP C710616 33B <1>
 Published in Japan December 2009

Revision number
 Date of publication

Date of Publication	Rev. No.	Section	Revised Content		
November 2015	<9>	Front cover	Revision: Format		
		All	Revision: Reviewed and corrected entire documentation.		
		Chapter 10	Revision: EN81-1/20 conform circuit with one motor contactor		
		Chapter 11	Addition: EN81-20 conform circuit with no motor contactor		
June 2014	<8>	Back cover	Revision: Address, format		
		All	Addition: Models CIMR-L□□F□ in compliance with IEC/EN 61508 SIL3 Safety Integrity Level 3 Revision: Reviewed and corrected entire documentation		
		January 2014	<7>	All	Revision: · Reviewed and corrected entire documentation · Upgraded the software version to S7017 and S7200
		December 2013	<6>	Back cover	Revision: Address
October 2012	<5>	All	Addition: Smaller drive capacities added along with corresponding data Three-phase 200 V: CIMR-L□2A0008 and 2A0011 Three-phase 400 V: CIMR-L□4A0005 and 4A0006		
March 2012	<4>	Front cover, back cover	Revision: Format		
		All	Revision: Reviewed and corrected entire documentation		
August 2010	<3>	All	Revision: Reviewed and corrected entire documentation		
		Chapter 9	Revision: Safe Disable Input Function		
		Chapter 11	Revision: UL Standards		
		Back cover	Revision: Address		
May 2010	<2>	All	Addition: Larger drive capacities added along with corresponding data Three-phase 200V: CIMR-L□2A0215 to 2A0415 Three-phase 400V: CIMR-L□4A0180 and 4A0216 Revision: · Reviewed and corrected entire documentation · Upgraded the software version to S7011 and S7012		
		Chapter 1	Deletion: Descriptions on UL/cUL standards compliance		
		Chapter 11	Addition: UL Standards		
December 2009	<1>	All	Revision: Ground wiring		
		Chapter 9	Revision: Safe disable input function		
		Chapter 10	Revision: EN81-1 conform circuit with one motor contactor		
August 2009	–	–	First edition		

YASKAWA AC Drive L1000A

AC Drive for Elevator Applications

Quick Start Guide

YASKAWA EUROPE GmbH

185, Hauptstraße, Eschborn, 65760, Germany
Phone: +49 (0)6196 569 300 Fax: +49 (0)6196 569 398
E-mail: info@yaskawa.eu.com Internet: <http://www.yaskawa.eu.com>

DRIVE CENTER (INVERTER PLANT)

2-13-1, Nishimiyaichi, Yukuhashi, Fukuoka, 824-8511, Japan
Phone: +81 (0)930 25 3844 Fax: +81 (0)930 25 4369
Internet: <http://www.yaskawa.co.jp>

YASKAWA AMERICA, INC.

2121, Norman Drive South, Waukegan, IL 60085, U.S.A.
Phone: +1 800 YASKAWA (927-5292) or +1 847 887 7000 Fax: +1 847 887 7310
Internet: <http://www.yaskawa.com>

YASKAWA

YASKAWA ELECTRIC CORPORATION

In the event that the end user of this product is to be the military and said product is to be employed in any weapons systems or the manufacture thereof, the export will fall under the relevant regulations as stipulated in the Foreign Exchange and Foreign Trade Regulations. Therefore, be sure to follow all procedures and submit all relevant documentation according to any and all rules, regulations and laws that may apply. Specifications are subject to change without notice for ongoing product modifications and improvements.

© 2009-2015 YASKAWA ELECTRIC CORPORATION



TOEPC71061633

MANUAL NO. TOEP C710616 33H <9>
Published in Japan November 2015
14-10-7_YEU
Original instructions